

---

# Understanding and Specifying Kart Series Multi-Use Seating



## Product Details

Kart Series	230
Dimensions	232



## Specifying

Nesting Chairs	234
Stools	238

# Kart Series

**Kart seating collection**

offers solutions for classrooms, cafeterias, training rooms, and multipurpose rooms.

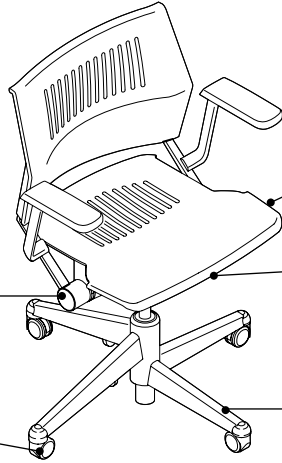

**Seat height** adjusts within a 5" range with a pneumatic adjustment mechanism.

**Casters** have hard, dual wheels that roll smoothly on carpets. Soft, dark grey treaded, dual-wheel roll-control casters are available for use on hard floors or mats.

*Tip: Do not roll the chair across asphalt during installation as this may damage the casters.*

**Arms, glides, and back-seat connection** will always be black.

**Flip** the seat on the nesting chairs and eight Kart chairs can nest in the space of two and a half.

**Tilt tension adjustment** allows you to control the amount of resistance needed for reclining.

**Four-arm base** is standard on nesting chairs.

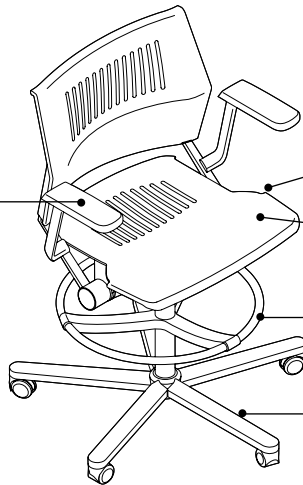

**Back lock mechanism** allow users to lock the back in an upright position.

**Stools** do not nest.

**Adjustable 19" diameter chrome foot ring.**

**The stool** has a five-star base.

**Product Details**



**Nesting chairs and stools with casters** are available with or without arms.

**Kart** is available non-upholstered, upholstered seat only, or upholstered seat and back.

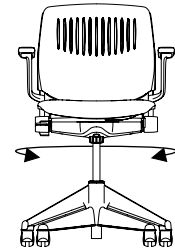

**360° swivel motion** is locked when in nesting mode (seat up and engaged with base).

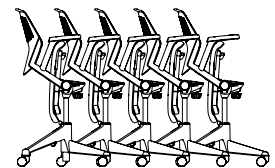

**Nesting chairs** have the ability to nest five chairs in a space of 4'6", or 54". Each additional chair adds 7" to the overall nesting length.

**Kart chairs and stools** come standard uncartoned. There is an option to have Kart cartoned.

## Adjustment Features

**Adjustability instructions** are included with every swivel-base chair. Instructions can also be found at [www.steelcase.com](http://www.steelcase.com).

## Seat Adjustments

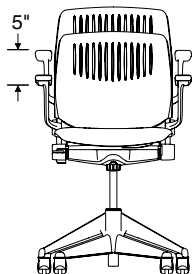

**Seat height** adjusts pneumatically. To lower, hold handle up while seated. To raise, hold handle up and keep your weight off the chair. Range of adjustability is 5".

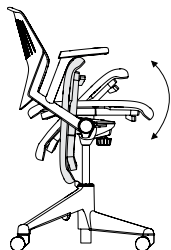

**Seat** flips on nesting chairs. Pull the lever under the seat toward the front of the chair and tip the seat up. As the seat releases, the pneumatic lift activates and pushes the chair to its full height position. To lock, spin the chair until the seat engages with the base tooth.

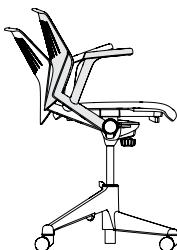

**Tilt Tension.** To loosen, turn control knob counter-clockwise. To tighten, turn control knob clockwise.

## Back Adjustments

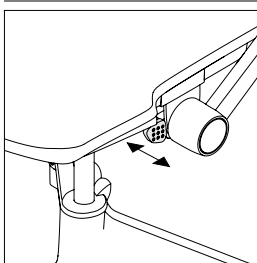

**Forward back lock** on nesting and stool with casters. Lean forward, pull triangular knob out until it stops.

## Foot Ring Adjustments

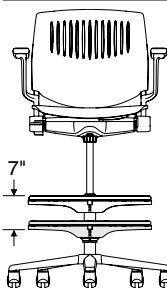

**19" chrome foot ring** adjusts 8½"H to 15½"H by rotating it left or right.

## Other Features

**Hard dual-wheel casters for use on soft floors** come standard on nesting chairs as well as stools with casters.

**Soft dual-wheel casters for hard floors on nesting or five-arm base stools** are available for specific applications.

## Surface Materials

▶ See surface materials on page 634 for specific availability or refer to the *Surface Materials Reference Manual* for further information.

**Fabric and leathers** will appear loose with comfort wrinkles when upholstered.

**Back frame and seat shell** are plastic on all Kart models.

## Upholstery

- Fabric
- Leather
- Elmosoft Leather

## Hard Components

(Base, back supports, and arm support bar)

- Aluminum with paint

(Rub strips, yoke strips, non-upholstered seat, and back)

- Plastic

(Café stool steel frame)

- Paint

## Arm Caps

- Black plastic

## Foot Ring

- Chrome

## Casters

- Black only

## Glides

- Standard on café stool and optional on nesting and stools with casters.

## Extra Foam

- Available on nesting and stools with casters.

## Programs & Services

▶ See the *Surface Materials Reference Manual* for further detail about programs and services offered for seating.

## The Customer's Own Material (COM) Program

offers the opportunity for customers to select fabrics that are not offered through the standard Steelcase surface materials program for use on Steelcase products. Through the COM program, Steelcase will test your materials for application on Steelcase products. Once approved, you can place your order. Steelcase will facilitate the entire ordering process and give you a production schedule. Steelcase will order the COM fabric directly from the textile manufacturer. For up-to-date information regarding fabric test results for all COM fabrics and details regarding yardage requirements for most Seating lines, visit the COM website. To locate the COM website:

- Visit [www.steelcase.com](http://www.steelcase.com)

## Dimensions

▶ Page 232

## Resources

### Printed Materials

▶ Kart Brochure

### Online Resources

▶ Product Environmental Profiles, which provide key environmental attributes and product certifications can be found by searching for Steelcase at *Origin.build*.

# Dimensions

## Kart Series

Features	Overall Depth	Width	Height	Seat Depth	Seat Width	Seat Height from Floor	Ring Height from Floor	Back Width	Width Between Arms
----------	---------------	-------	--------	------------	------------	------------------------	------------------------	------------	--------------------

**Kart**

**Nesting Chairs**

With arms	22½"	24½"	38"	17¾"	19"	16" to 21"	N.A.	18"	19½"
Without arms	22½"	24½"	38"	17¾"	19"	16" to 21"	N.A.	18"	N.A.

**Stools with Casters**

With arms	22½"	24½"	44"	17¾"	19"	21" to 28½"	8½" to 15½"	18"	19½"
Without arms	22½"	24½"	44"	17¾"	19"	21" to 28½"	8½" to 15½"	18"	N.A.

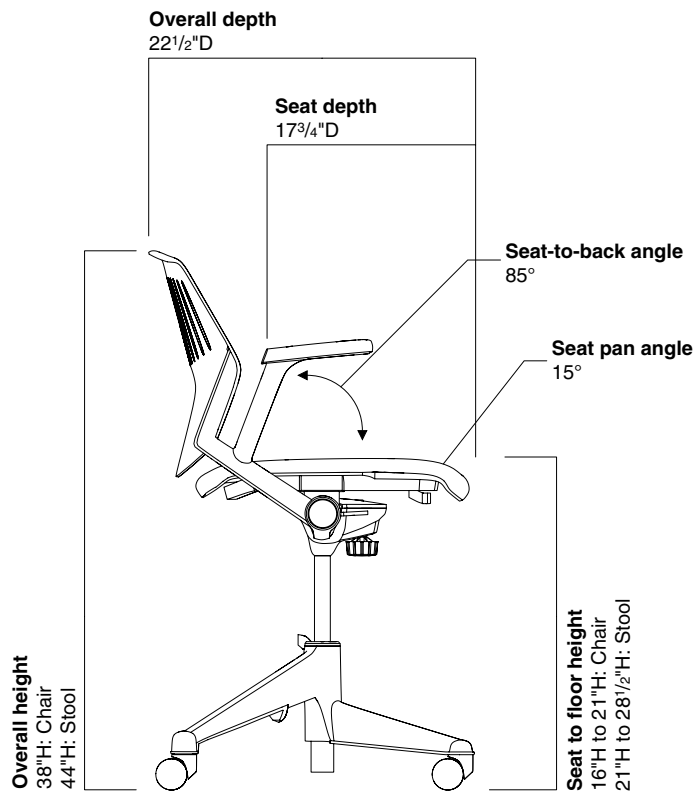
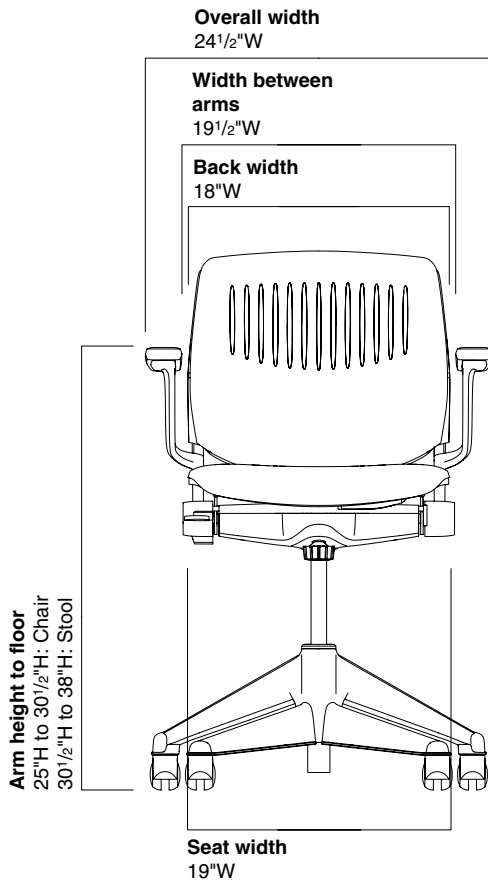



# Kart Nesting Chairs



*Tip: Fabrics and leathers will appear loose with comfort wrinkles when upholstered.*

*Tip: For Customer's Own Material or Leather, see necessary requirements, important processing instructions, and ordering information.*

▶ See *Surface Materials Reference Manual*.

Standard Includes	Required to Specify
<p>▶ Need help? Product details, page 230</p> <ul style="list-style-type: none"> <li>• Four-prong Kart nesting base with nylon base tooth: die-cast aluminum with powder coat</li> <li>• Rub strips: injection-molded black polypropylene</li> <li>• Yoke strips: injection-molded black polypropylene</li> <li>• Hard, dual-wheel casters for use on carpet: black plastic</li> <li>• Seat and back: black or gray textured contoured, injection-molded glass-filled Polyurethane</li> <li>• Upholstered seat or upholstered seat and back, if selected: molded urethane foam over injection-molded polypropylene inner shell(s)</li> <li>• Folding seat with self-aligning features</li> <li>• Back supports: one-piece die-cast aluminum</li> <li>• Arms, if selected: die-cast aluminum support bar with black, molded, self-skinning polyurethane arm cap</li> <li>• Pneumatic height adjustment</li> <li>• Tilt tension adjustment</li> <li>• Zero front rise</li> <li>• Forward back lock</li> </ul>	<ol style="list-style-type: none"> <li>1 Style number</li> <li>2 Powder coat color number for base</li> <li>3 Plastic color number for seat and back</li> <li>4 Fabric or leather color number for upholstery, if selected</li> <li>5 Options, if selected (see below)</li> </ol> <p>▶ See <i>Surface Materials</i>, page 634.</p>

Surface Materials	Options	U.S. Price	Required to Specify
	<b>Non-upholstered chair</b>		
	• Plastic	No cost	Specify plastic color number.
	<b>Upholstery on seat and back</b>		
	• Fabric price group 1	No cost	Specify fabric color number.
	• Fabric price group 2	+\$ 31	Specify fabric color number.
	• Fabric price group 3	+\$ 73	Specify fabric color number.
	• Fabric price group 4	+\$102	Specify fabric color number.
	• Fabric price group 5	+\$124	Specify fabric color number.
	• Fabric price group 6	+\$150	Specify fabric color number.
	• Fabric price group 7	+\$181	Specify fabric color number.
	• Fabric price group 8	+\$225	Specify fabric color number.
	• Fabric price group 9	+\$263	Specify fabric color number.
	• Fabric price group 10	+\$317	Specify fabric color number.
	• Steelcase leather upholstery	+\$150	Specify leather color number.
	• Elmosoft leather upholstery	+\$301	Specify Elmosoft leather color number.
	• Customer's Own Material (COM)	+\$ 60	▶ See <i>Surface Materials Reference Manual</i> to specify.
	• Customer's Own Leather (COL)	No cost	▶ See <i>Surface Materials Reference Manual</i> to specify.
	<b>Contrasting upholstery on seat and back</b>		
	• Contrasting fabrics	+\$ 46	Add suffix <b>K</b> to the style number and specify fabric color numbers.
	<b>Contrasting upholstery on seat</b>		
	• Fabric price group 1	No cost	Specify fabric color number.
	• Fabric price group 2	+\$ 16	Specify fabric color number.
	• Fabric price group 3	+\$ 34	Specify fabric color number.
	• Fabric price group 4	+\$ 49	Specify fabric color number.
	• Fabric price group 5	+\$ 61	Specify fabric color number.
	• Fabric price group 6	+\$ 76	Specify fabric color number.
	• Fabric price group 7	+\$ 92	Specify fabric color number.
	• Fabric price group 8	+\$112	Specify fabric color number.
	• Fabric price group 9	+\$132	Specify fabric color number.
	• Fabric price group 10	+\$159	Specify fabric color number.
	• Steelcase leather upholstery	+\$ 76	Specify leather color number.
	• Elmosoft leather upholstery	+\$147	Specify leather color number.
	• Customer's Own Material/ Vinyl (COM)	+\$ 28	▶ See <i>Surface Materials Reference Manual</i> to specify.
	• Customer's Own Leather (COL)	No cost	▶ See <i>Surface Materials Reference Manual</i> to specify.

▶ Detailed dimensions, page 232



## For Canadian Pricing

Multiply U.S. Price by the Canadian price factor.

▶ See page 1 for details.

▶ Options, continued on next page

► Options, continued from previous page

Options	U.S. Price	Required to Specify
<b>Surface Materials, continued</b> <b>Contrasting upholstery on back</b> <ul style="list-style-type: none"> <li>• Fabric price group 1</li> <li>• Fabric price group 2</li> <li>• Fabric price group 3</li> <li>• Fabric price group 4</li> <li>• Fabric price group 5</li> <li>• Fabric price group 6</li> <li>• Fabric price group 7</li> <li>• Fabric price group 8</li> <li>• Fabric price group 9</li> <li>• Fabric price group 10</li> <li>• Steelcase leather upholstery</li> <li>• Elmosoft leather upholstery</li> <li>• Customer's Own Material/ Vinyl (COM)</li> <li>• Customer's Own Leather (COL)</li> </ul>	<ul style="list-style-type: none"> <li>No cost</li> <li>+\$ 16</li> <li>+\$ 35</li> <li>+\$ 51</li> <li>+\$ 62</li> <li>+\$ 76</li> <li>+\$ 92</li> <li>+\$112</li> <li>+\$133</li> <li>+\$159</li> <li>+\$ 76</li> <li>+\$150</li> <li>+\$ 31</li> <li>No cost</li> </ul>	<ul style="list-style-type: none"> <li>Specify fabric color number.</li> <li>Specify fabric color number.</li> <li>Specify fabric color number.</li> <li>Specify fabric color number.</li> <li>Specify fabric color number.</li> <li>Specify fabric color number.</li> <li>Specify fabric color number.</li> <li>Specify fabric color number.</li> <li>Specify fabric color number.</li> <li>Specify fabric color number.</li> <li>Specify leather color number.</li> <li>Specify leather color number.</li> <li>See <i>Surface Materials Reference Manual</i> to specify.</li> <li>See <i>Surface Materials Reference Manual</i> to specify.</li> </ul>
<b>Casters</b>	<ul style="list-style-type: none"> <li>• Soft, dark grey treaded, dual-wheel roll-control casters for use on hard floors</li> </ul>	+\$ 62 Specify <i>with soft roll-control casters</i> .
<b>Extra Foam</b>	<ul style="list-style-type: none"> <li>• Extra foam</li> </ul>	+\$108 Specify <i>with extra foam</i> .
<b>Glide</b>	<ul style="list-style-type: none"> <li>• Glide</li> </ul>	+\$ 53 Specify <i>with glides</i> .
<b>Related Products</b>	<ul style="list-style-type: none"> <li>• Pouch and leash</li> </ul>	► Page 236

Specification Information

Style Number	U.S. Base Price

Non-Upholstered with Arms

126A101	\$1313
---------	--------

Non-Upholstered without Arms

126A100	\$1197
---------	--------

Upholstered Seat with Arms

126A201S	\$1583
----------	--------

► Specification Information, continued on next page



**For Canadian Pricing**

Multiply U.S. Price by the Canadian price factor.

► See page 1 for details.

Kart Nesting Chairs, continued

► Specification Information, continued from previous page

**Specification Information**

• Style • Number	• U.S. • Base • Price



**Upholstered Seat without Arms**

<b>126A200S</b>	\$1467
-----------------	--------



**Upholstered Seat and Back with Arms**

<b>126A201</b>	\$1641
----------------	--------



**Upholstered Seat and Back without Arms**

<b>126A200</b>	\$1525
----------------	--------

**Pouch and Leash for Use on Kart Nesting Chairs**

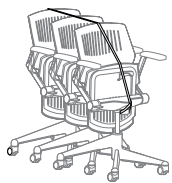

Standard Includes	Required to Specify
-------------------	---------------------

- Leash to retain up to 10 nested chairs
- Pouch to store leash
- Pouch attaches to bottom of seat

Style number

**Specification Information**

• Style • Number	• U.S. • Price

<b>126900</b>	\$108
---------------	-------

 **For Canadian Pricing**  
 Multiply U.S. Price by the Canadian price factor.  
 ► See page 1 for details.





# Kart Stools

with Casters



Tip: Stools do not nest.

Tip: Fabrics and leathers will appear loose with comfort wrinkles when upholstered.

Tip: For Customer's Own Material or Leather, see necessary requirements, important processing instructions, and ordering information. ▶ See *Surface Materials Reference Manual*.

▶ Detailed dimensions, page 232



**For Canadian Pricing**  
Multiply U.S. Price by the Canadian price factor.  
▶ See page 1 for details.

Standard Includes	Required to Specify
-------------------	---------------------

- |  |  |  |
|--|--|--|
| <ul style="list-style-type: none"> <li>▶ Need help? Product details, page 230</li> </ul> | <ul style="list-style-type: none"> <li>• Five-prong base with 25" span: one-piece die-cast aluminum with powder coat color</li> <li>• Telescoping hub cover: black plastic</li> <li>• Adjustable 19" diameter chrome foot ring</li> <li>• Hard, dual-wheel casters for use on carpet: black</li> <li>• Seat and back: black or gray textured contoured, injection-molded glass-filled polypropylene</li> <li>• Upholstered seat or upholstered seat and back, if selected: molded urethane foam over injection-molded polypropylene inner shell(s)</li> <li>• Back supports: one-piece die-cast aluminum</li> <li>• Arms, if selected: die-cast aluminum support bar with black, molded, self-skinning polyurethane arm cap</li> <li>• Pneumatic height adjustment</li> <li>• Tilt tension adjustment</li> <li>• Zero front rise</li> <li>• Forward back lock</li> </ul> | <ol style="list-style-type: none"> <li>1 Style number</li> <li>2 Powder coat color number for base</li> <li>3 Plastic color number for seat and back</li> <li>4 Fabric or leather color number for upholstery, if selected</li> <li>5 Options, if selected (see below)</li> </ol> <p>▶ See <i>Surface Materials</i>, page 634.</p> |
|--|--|--|

Surface Materials	Options	U.S. Price	Required to Specify
-------------------	---------	------------	---------------------

<b>Surface Materials</b>	<b>Non-upholstered stool</b>		
	• Plastic	No cost	Specify plastic color number.
	<b>Upholstery on seat and back</b>		
	• Fabric price group 1	No cost	Specify fabric color number.
	• Fabric price group 2	+\$ 31	Specify fabric color number.
	• Fabric price group 3	+\$ 73	Specify fabric color number.
	• Fabric price group 4	+\$102	Specify fabric color number.
	• Fabric price group 5	+\$124	Specify fabric color number.
	• Fabric price group 6	+\$150	Specify fabric color number.
	• Fabric price group 7	+\$181	Specify fabric color number.
	• Fabric price group 8	+\$225	Specify fabric color number.
	• Fabric price group 9	+\$263	Specify fabric color number.
	• Fabric price group 10	+\$317	Specify fabric color number.
	• Steelcase leather upholstery	+\$150	Specify leather color number.
	• Elmosoft leather upholstery	+\$301	Specify Elmosoft leather color number.
• Customer's Own Material (COM)	+\$ 60	▶ See <i>Surface Materials Reference Manual</i> to specify.	
• Customer's Own Leather (COL)	No cost	▶ See <i>Surface Materials Reference Manual</i> to specify.	
<b>Contrasting upholstery on seat and back</b>			
• Contrasting fabrics	+\$ 46	Add suffix <b>K</b> to the style number and specify fabric color numbers.	
<b>Contrasting upholstery on seat</b>			
• Fabric price group 1	No cost	Specify fabric color number.	
• Fabric price group 2	+\$ 16	Specify fabric color number.	
• Fabric price group 3	+\$ 34	Specify fabric color number.	
• Fabric price group 4	+\$ 49	Specify fabric color number.	
• Fabric price group 5	+\$ 61	Specify fabric color number.	
• Fabric price group 6	+\$ 76	Specify fabric color number.	
• Fabric price group 7	+\$ 92	Specify fabric color number.	
• Fabric price group 8	+\$112	Specify fabric color number.	
• Fabric price group 9	+\$132	Specify fabric color number.	
• Fabric price group 10	+\$159	Specify fabric color number.	
• Steelcase leather upholstery	+\$ 76	Specify leather color number.	
• Elmosoft leather upholstery	+\$147	Specify leather color number.	
• Customer's Own Material/ Vinyl (COM)	+\$ 28	▶ See <i>Surface Materials Reference Manual</i> to specify.	
• Customer's Own Leather (COL)	No cost	▶ See <i>Surface Materials Reference Manual</i> to specify.	

▶ Options, continued on next page

► Options, continued from previous page

Options	U.S. Price	Required to Specify
<b>Surface Materials, continued</b> <b>Contrasting upholstery on back</b> <ul style="list-style-type: none"> <li>• Fabric price group 1</li> <li>• Fabric price group 2</li> <li>• Fabric price group 3</li> <li>• Fabric price group 4</li> <li>• Fabric price group 5</li> <li>• Fabric price group 6</li> <li>• Fabric price group 7</li> <li>• Fabric price group 8</li> <li>• Fabric price group 9</li> <li>• Fabric price group 10</li> <li>• Steelcase leather upholstery</li> <li>• Elmosoft leather upholstery</li> <li>• Customer's Own Material/ Vinyl (COM)</li> <li>• Customer's Own Leather (COL)</li> </ul>	<ul style="list-style-type: none"> <li>No cost</li> <li>+\$ 16</li> <li>+\$ 35</li> <li>+\$ 51</li> <li>+\$ 62</li> <li>+\$ 76</li> <li>+\$ 92</li> <li>+\$112</li> <li>+\$133</li> <li>+\$159</li> <li>+\$ 76</li> <li>+\$150</li> <li>+\$ 31</li> <li>No cost</li> </ul>	<ul style="list-style-type: none"> <li>Specify fabric color number.</li> <li>Specify fabric color number.</li> <li>Specify fabric color number.</li> <li>Specify fabric color number.</li> <li>Specify fabric color number.</li> <li>Specify fabric color number.</li> <li>Specify fabric color number.</li> <li>Specify fabric color number.</li> <li>Specify fabric color number.</li> <li>Specify fabric color number.</li> <li>Specify leather color number.</li> <li>Specify leather color number.</li> <li>See <i>Surface Materials Reference Manual</i> to specify.</li> <li>See <i>Surface Materials Reference Manual</i> to specify.</li> </ul>
<b>Casters</b> <ul style="list-style-type: none"> <li>• Soft, dark grey treaded, dual-wheel roll-control casters for use on hard floors</li> </ul>	<ul style="list-style-type: none"> <li>+\$ 62</li> </ul>	<ul style="list-style-type: none"> <li>Specify <i>with soft roll-control casters</i>.</li> </ul>
<b>Extra Foam</b> <ul style="list-style-type: none"> <li>• Extra foam</li> </ul>	<ul style="list-style-type: none"> <li>+\$108</li> </ul>	<ul style="list-style-type: none"> <li>Specify <i>with extra foam</i>.</li> </ul>
<b>Glide</b> <ul style="list-style-type: none"> <li>• Glide</li> </ul>	<ul style="list-style-type: none"> <li>+\$ 53</li> </ul>	<ul style="list-style-type: none"> <li>Specify <i>with glides</i>.</li> </ul>

Specification Information

Style Number	U.S. Base Price
.....	.....

**Non-Upholstered with Arms**

126B101ST \$1550

.....

**Non-Upholstered without Arms**

126B100ST \$1434

.....

**Upholstered Seat with Arms**

126B201SST \$1820

.....

► Specification Information, continued on next page



 **For Canadian Pricing**  
 Multiply U.S. Price by the Canadian price factor.  
 ► See page 1 for details.

► **Specification Information, continued from previous page**

**Specification Information**

• Style • Number • •	• U.S. • Base • Price •
-------------------------------	----------------------------------

**Upholstered Seat without Arms**

**126B200SST**     \$1704



**Upholstered Seat and Back with Arms**

**126B201ST**     \$1878



**Upholstered Seat and Back without Arms**

**126B200ST**     \$1762



**For Canadian Pricing**

Multiply U.S. Price by the Canadian price factor.

► See page 1 for details.