

# Be my guest<sup>®</sup>

STEP INTO A QUIET RETREAT



A phone booth that meets all the needs of today's workplace — **a quiet retreat** to focus or talk in private.

Be my guest® helps maximise productivity, frees up meeting room space, is quick and simple to assemble and easy to move around.

Our most competitively priced phone booth, Be my guest® showcases the quality and attention to detail that Orangebox is renowned for, carefully balancing considered design with ease of assembly and cost.



Form and function have been distilled to its essence – resulting in **elegant simplicity** and optimal performance.









## Your quiet retreat in a busy workplace.

Be my guest® is a quiet retreat where you can confidently talk in private without distracting others or being disturbed. The perfect space for private phone calls, online meetings or a sanctuary for focussed work.

The acoustic felt and laminated glass door, which is Class B rated, is fitted with magnetic seals, absorbing sound inside the phone booth – while at the same time blocking out external noise.

Be my guest® is designed to be quick and simple to assemble. All you need is:

**1 tool**  
**2 people**  
**30 minutes**





## Easy to move.

If you want to reconfigure your existing workspace, integrated castors make the phone booth easy to move. Simply wind up the feet to engage the castors to move your phone booth, and wind down to secure it when in position.

The phone booth is just as easy to disassemble if you decide to relocate in the future.

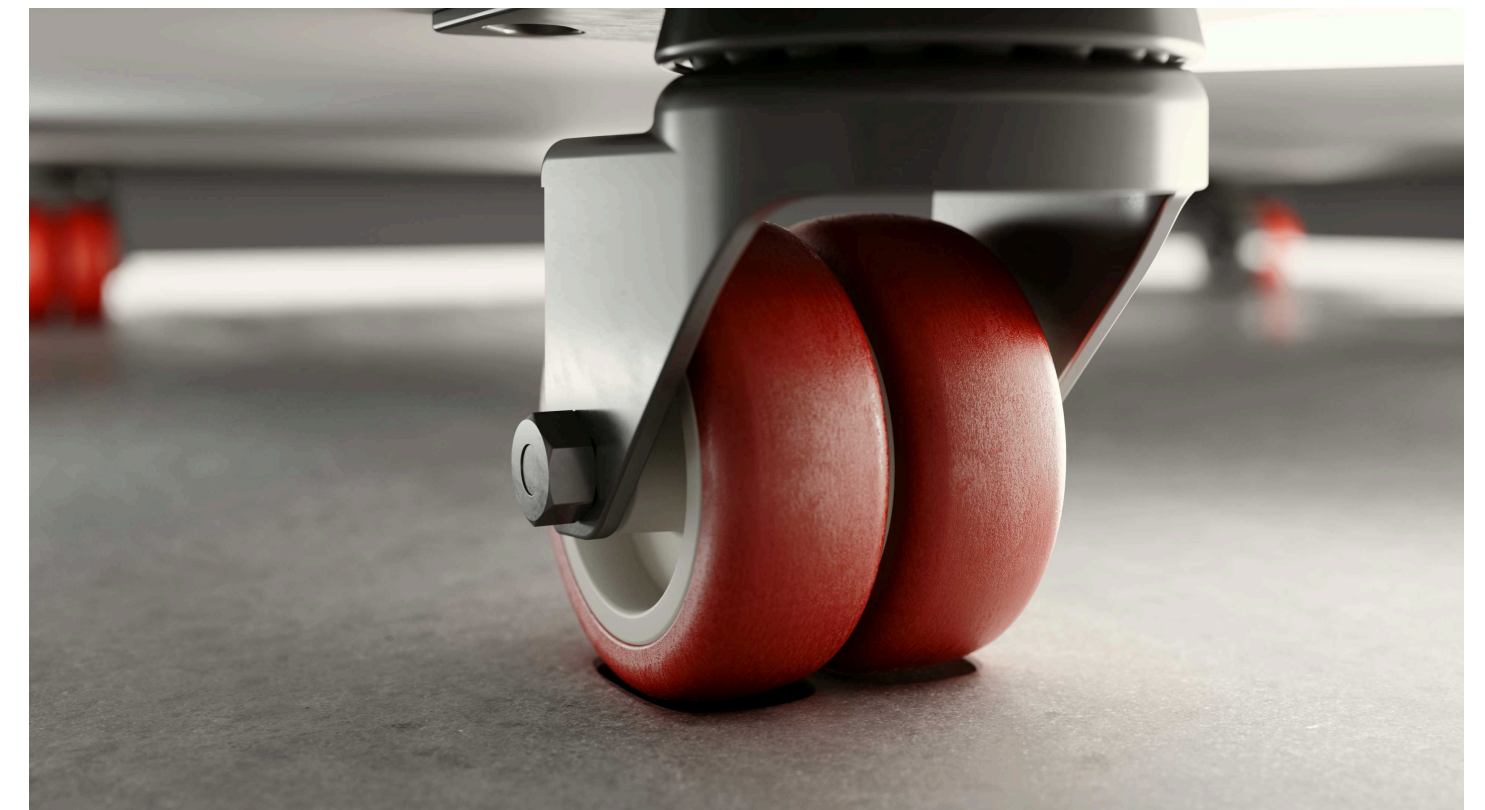

**Intelligent engineering.  
Carefully considered materials.**



## Mix and match. Make it your own.

With multiple colours and finishes, the choice of solid natural oak or stained black door handles, and the option of a D-shaped or L-shaped worksurface; Be my guest® can be configured to complement your workplace as a design feature.

Add our signature designed 'kink' for extra privacy and character, match it or contrast it with the side walls and worksurface.

## Customise your work surface.

The work surface comes in different colours and materials and can be installed at either seated height (74cm) or standing height (105cm).

It offers plenty of space for a laptop and has an integrated device holder. Options include a D-shaped work surface or a L-shaped work surface providing additional space for your belongings.





## Stay powered up and save energy.

Diffused lighting sets the perfect mood for video calls – the sensor activates as you enter the phone booth and saves energy by automatically switching off after use.

Stay powered up with USB-A and USB-C outlets, in addition to regional sockets.



## Keep cool and collected.

The sensor activated smart ventilation system keeps you cool and refreshed at all times with approximately 40 air changes per hour. The quiet fans continuously move cool air in and draw hot air out when in use.

Be my guest® sets the benchmark for compliance with every part rigorously tested.

Designed and engineered to last, with a 5-year warranty (and 2-year electrical warranty).

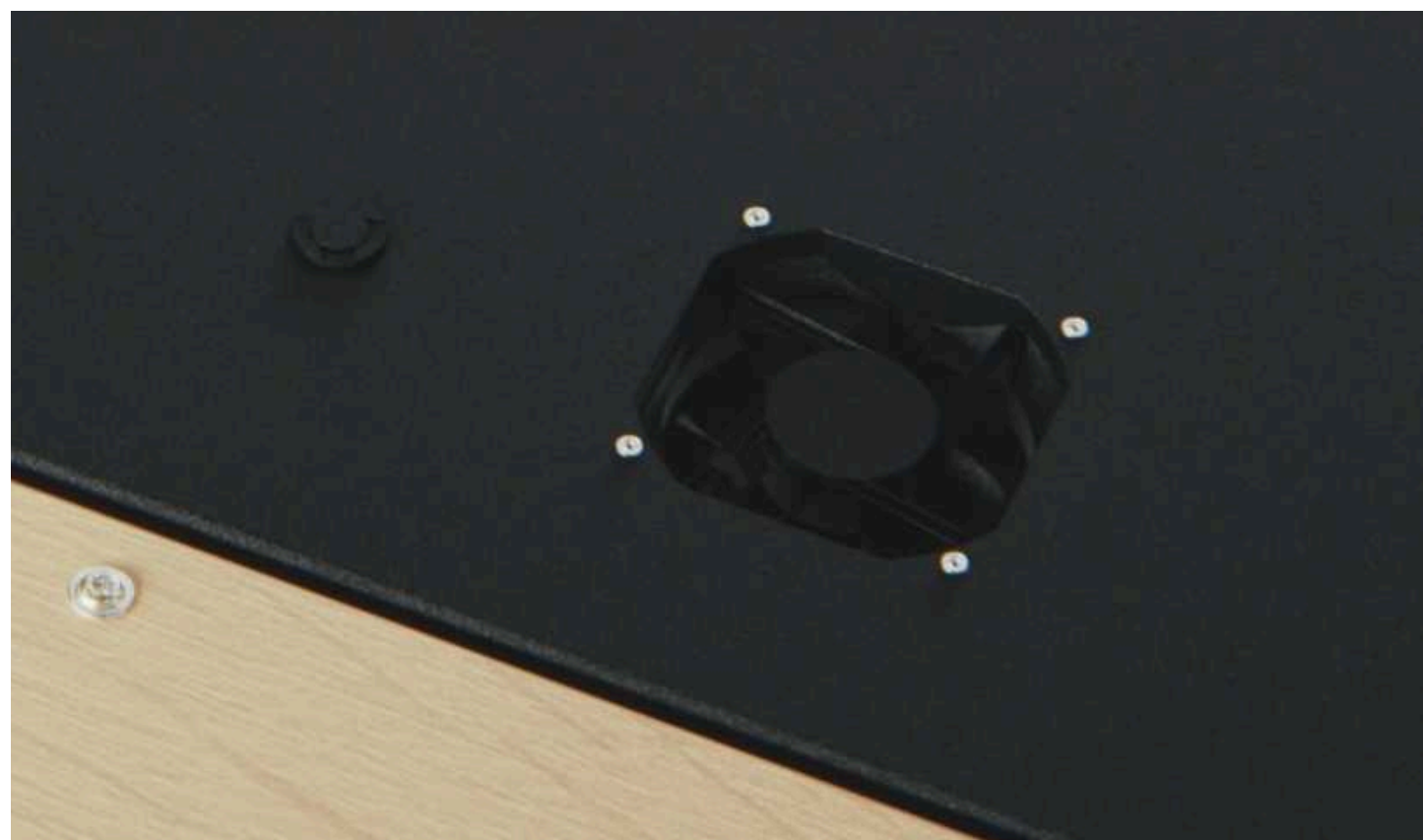





**A quiet retreat** away from the hustle and bustle of the workspace



**Acoustics**

ISO 23351-1 accredited  
Laminated acoustic glass  
Full frame magnetic sealed door

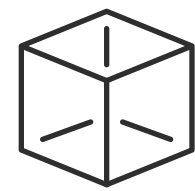

**Footprint**

1m x 1m x 2.26m

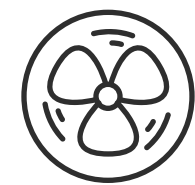

**Ventilation and air quality**

Approx. 40 air changes/hour  
ANSI/BIFMA e3-2019  
DIN EN 16516:2020-10  
Formaldehyde 0.5

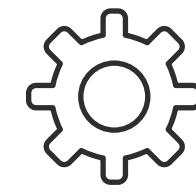

**Mechanical**

Door performance BS 6375-2  
ANSI/BIFMA X5.5-2016(R2021)  
ANSI/BIFMA X5.6-2016(R2021)  
ANSI/BIFMA X5.9-2016(R2021)  
BS EN 12600



**Electrical**

CB approved  
EN IEC 62368-1:2020/A11:2020  
EN 61000-6-1:2019  
EN 61000-6-3:2021  
EN 61000-3-2:2019  
EN 61000-3-3:2013+A1:2019  
BS EN 63000:2018  
Concealed LED light with anti-glare  
Energy consumption 100mW  
PIR sensor technology - auto activation



**Carbon footprint**

FSC accredited wood handles  
PEFC accredited external cladding



**Flammability**

Wall construction to EN13501-1

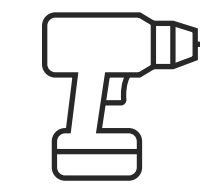

**Installation**

Comes flat-packed  
Easy installation: 1 tool, 2 people, 30 min.  
Built in castors for relocation

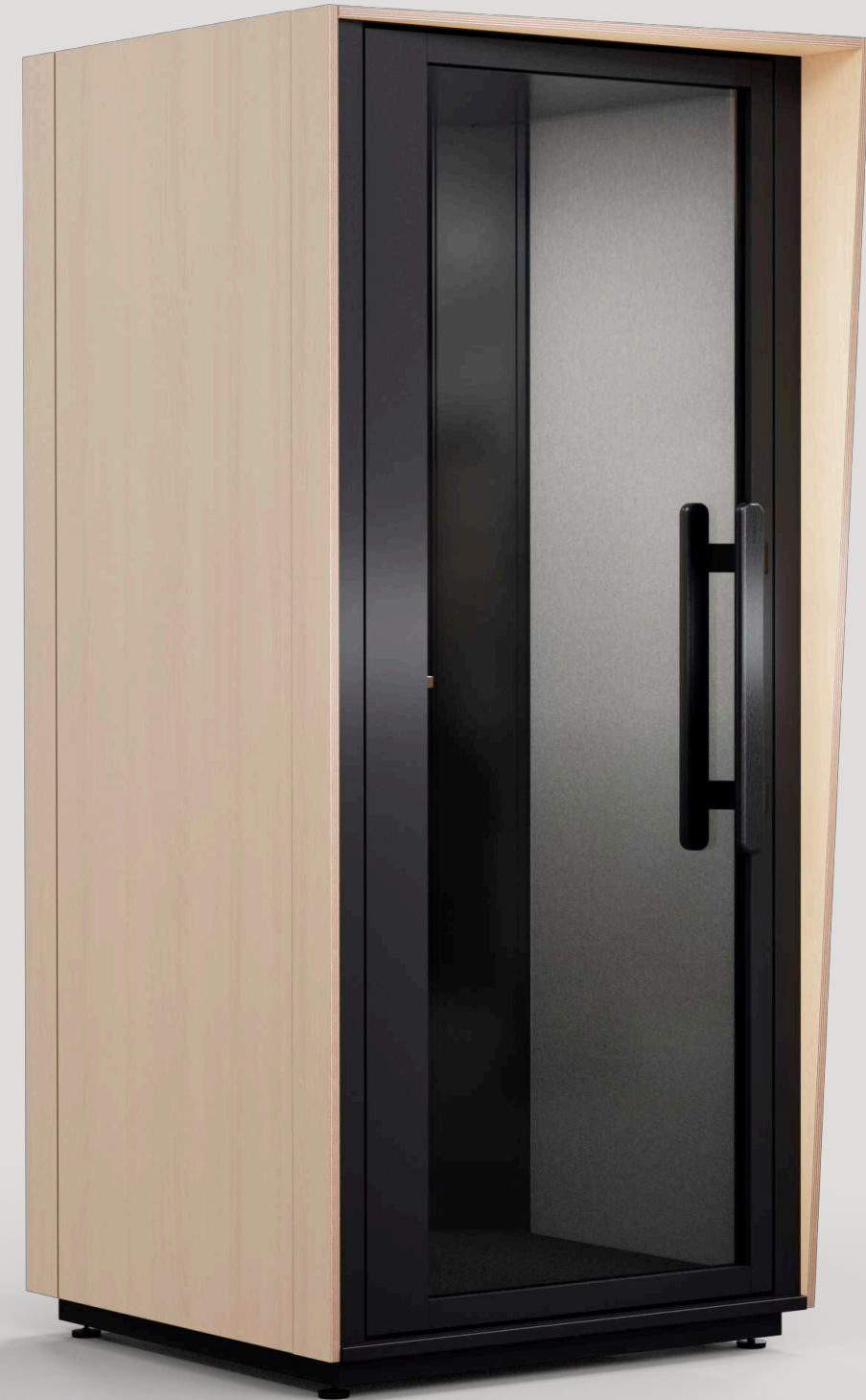

# Mix and match colours and finishes



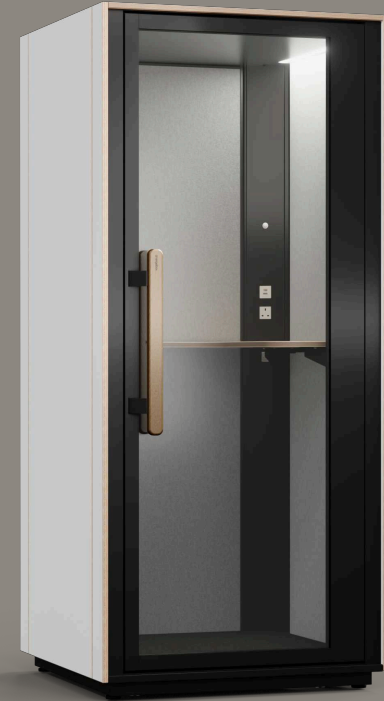

### Back cladding

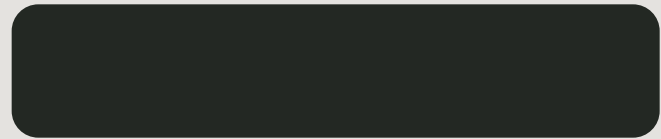

Back cladding comes in Melamine Merle as standard, but can be matched with any side cladding colours and finishes (see next page for options)

### Door handle

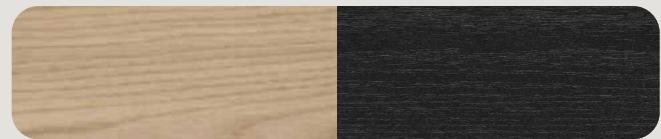

Solid oak or stained black

### Frame

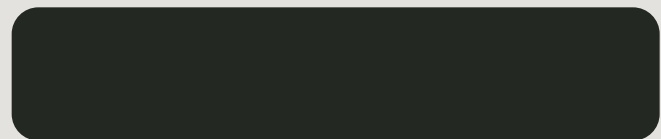

Pearl Black

See next page for colours and finishes for side cladding, back cladding, kink and work surface.

The frame finish is Pearl Black

The 'kink' comes in multiple colours and finishes.

Back cladding comes in Melamine Merle.

The work surface comes in multiple colours and finishes





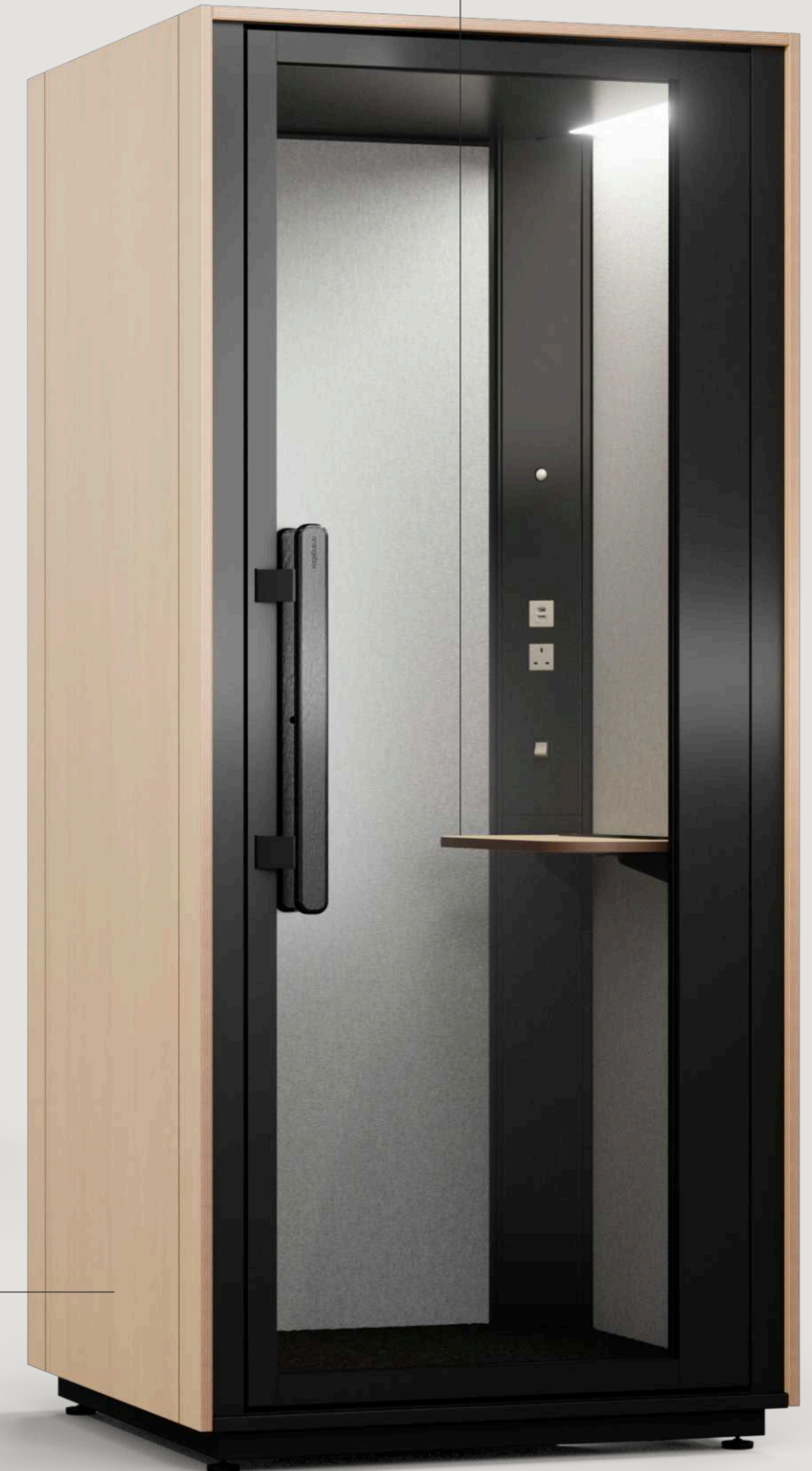

The door handle comes in solid oak or stained black



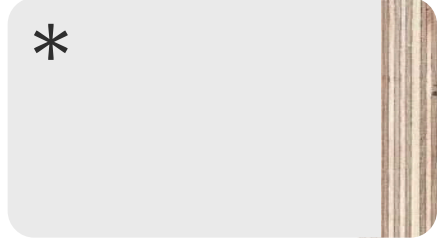
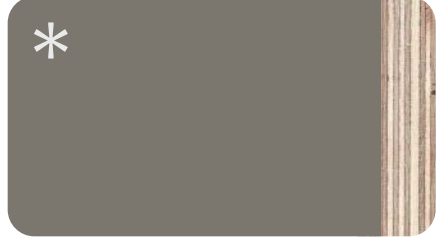
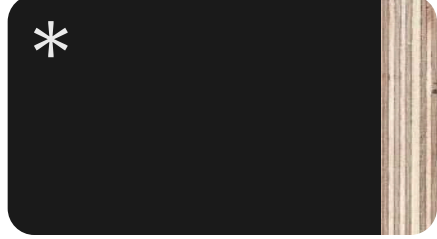

Side cladding comes in multiple colours and finishes





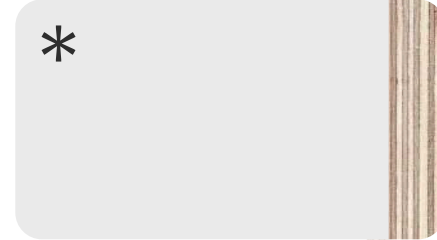
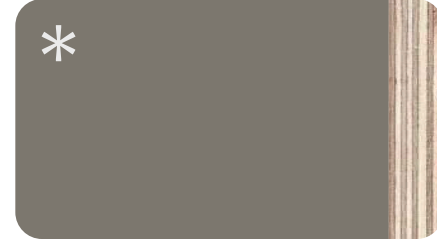



### Side cladding

-  Melamine  
Crystal Grey  
Same colour edge-band
-  Melamine  
Clear Oak  
Black edge-band
-  \* Perfect Sense  
U775 White Grey  
Ply edge-band
-  \* Perfect Sense  
U767 Cubiant Grey  
Ply edge-band
-  \* Perfect Sense  
U999 Black  
Ply edge-band
-  \* Perfect Sense  
U665 Green Stone  
Ply edge-band
-  \* Plywood

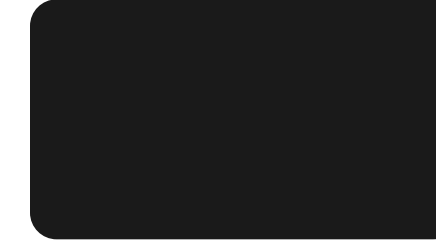

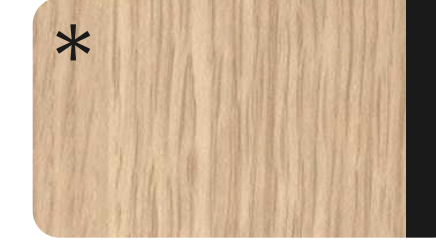
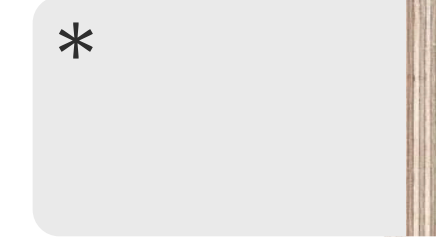
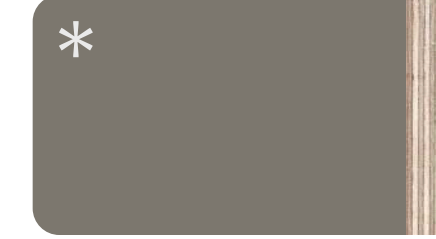
### Kink

-  \* Perfect Sense  
U775 White Grey  
Ply edge-band
-  \* Perfect Sense  
U767 Cubiant Grey  
Ply edge-band
-  \* Perfect Sense  
U999 Black  
Ply edge-band
-  \* Perfect Sense  
U665 Green Stone  
Ply edge-band
-  \* Plywood

### Rear cladding

-  Melamine  
Merle  
Black edge-band
-  \* Melamine  
Crystal Grey  
Same colour edge-band
-  \* Melamine  
Clear Oak  
Black edge-band
-  \* Perfect Sense  
U775 White Grey  
Ply edge-band
-  \* Perfect Sense  
U767 Cubiant Grey  
Ply edge-band
-  \* Perfect Sense  
U999 Black  
Ply edge-band
-  \* Perfect Sense  
U665 Green Stone  
Ply edge-band
-  \* Plywood

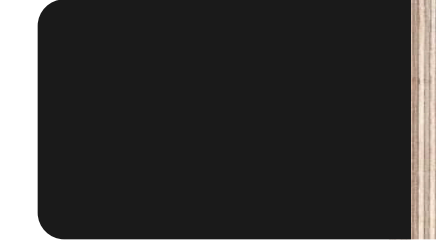
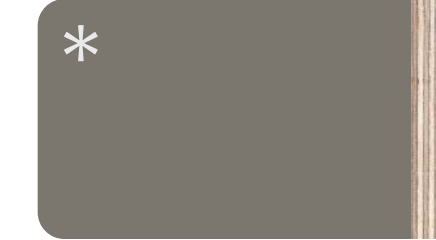
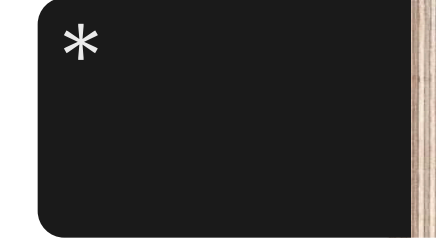
### Work surface

-  Melamine  
Merle  
Ply edge-band
-  \* Perfect Sense  
U767 Cubiant Grey  
Ply edge-band
-  \* Perfect Sense  
U999 Black  
Ply edge-band
-  \* Perfect Sense  
U665 Green Stone  
Ply edge-band
-  \* Plywood

Be my guest®  
**Connecting Spaces**

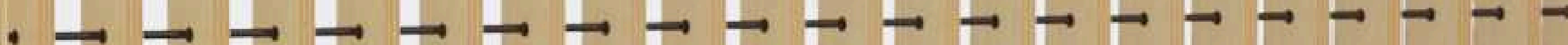



Be my guest – connecting spaces reimagines Be my guest® with a flexible, scalable, and quality design solution tailored for the modern workplace.

Designed to meet diverse privacy needs, the fully customisable system prioritises user comfort while blending seamlessly into any interior – making it the ideal choice for organisations, designers, and users alike.

By creating a neighborhood of spaces with varying levels of acoustic and visual privacy, Be my guest – connecting spaces redefines and enhances the workspace.

It intuitively meets users' needs by supporting private calls, quiet focus, and both virtual and in-person collaboration.

With fully enclosed, semi-open, and open configurations, Be my guest – connecting spaces adds functionality and flexibility into any environment.

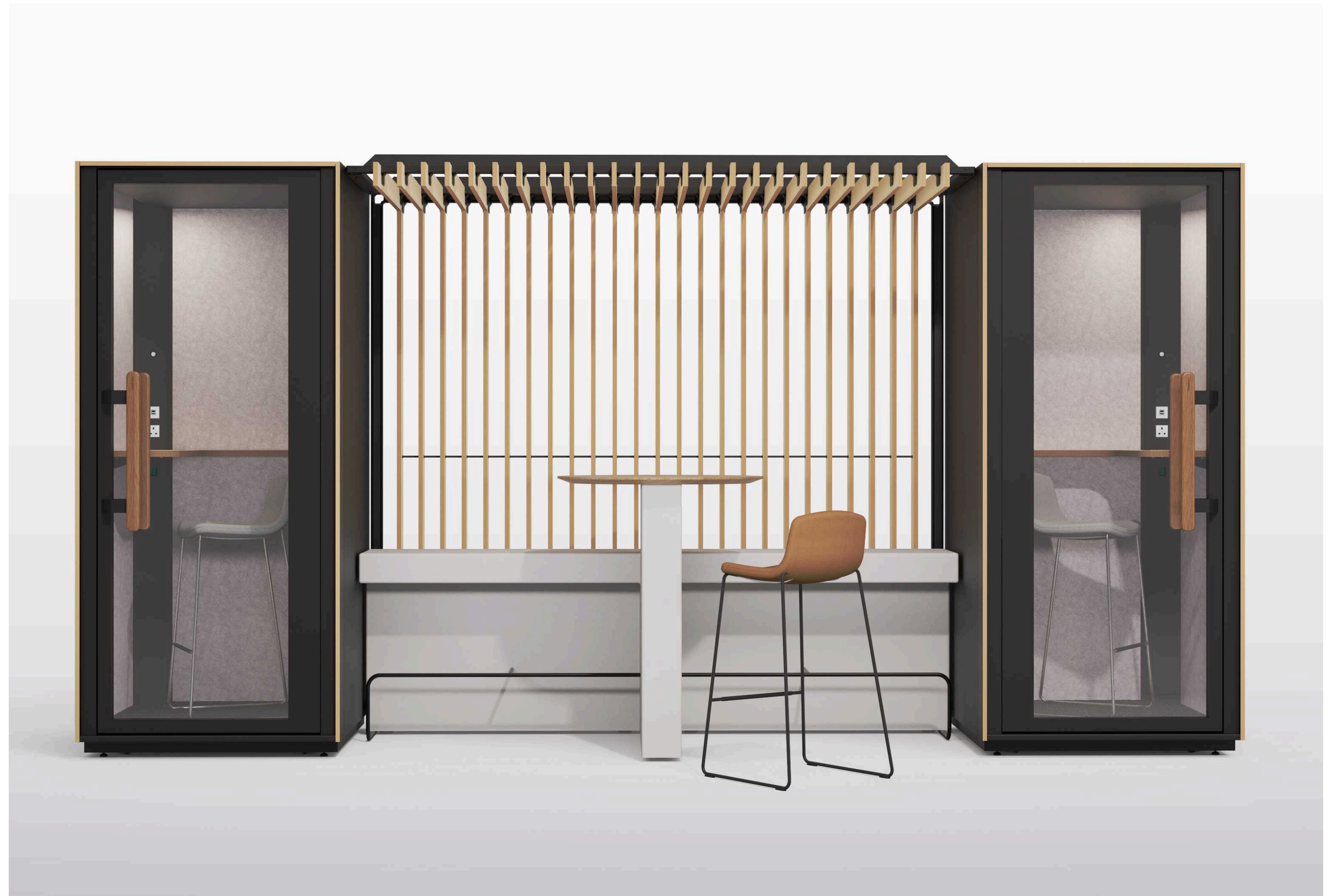



Available at two widths:  
1.5m and 2.45m

Designed to scale seamlessly, Be My Guest – connecting spaces can connect and cluster, allowing designers to integrate phone booths into larger configurations that align with overall interiors.



FEATURING ALLOW ME & BREAKER



FEATURING AVI & BREAKER

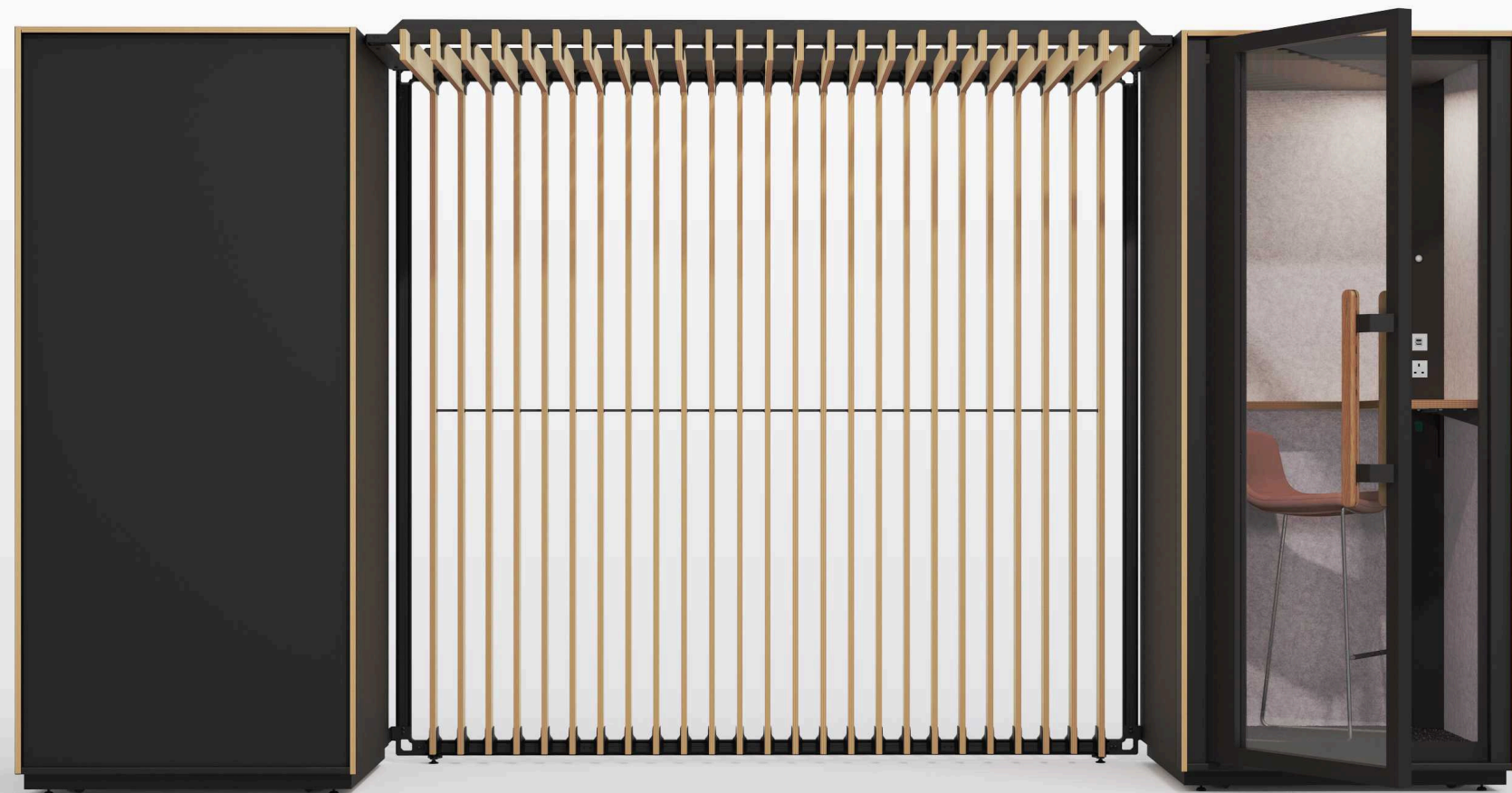

FEATURING FARNE



FEATURING TALL BORDER & CUBB



FEATURING ERCOL 420 & 305

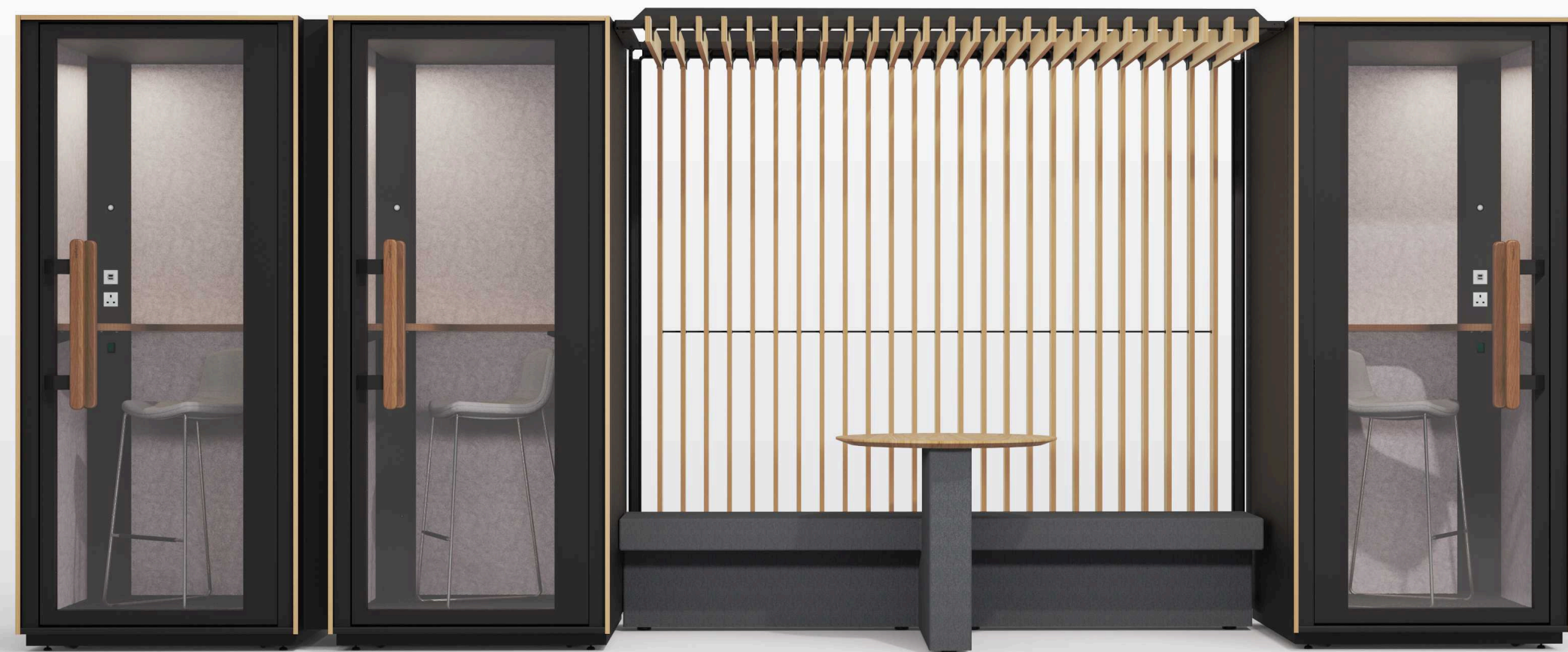

orangebox FEATURING LOW BORDER

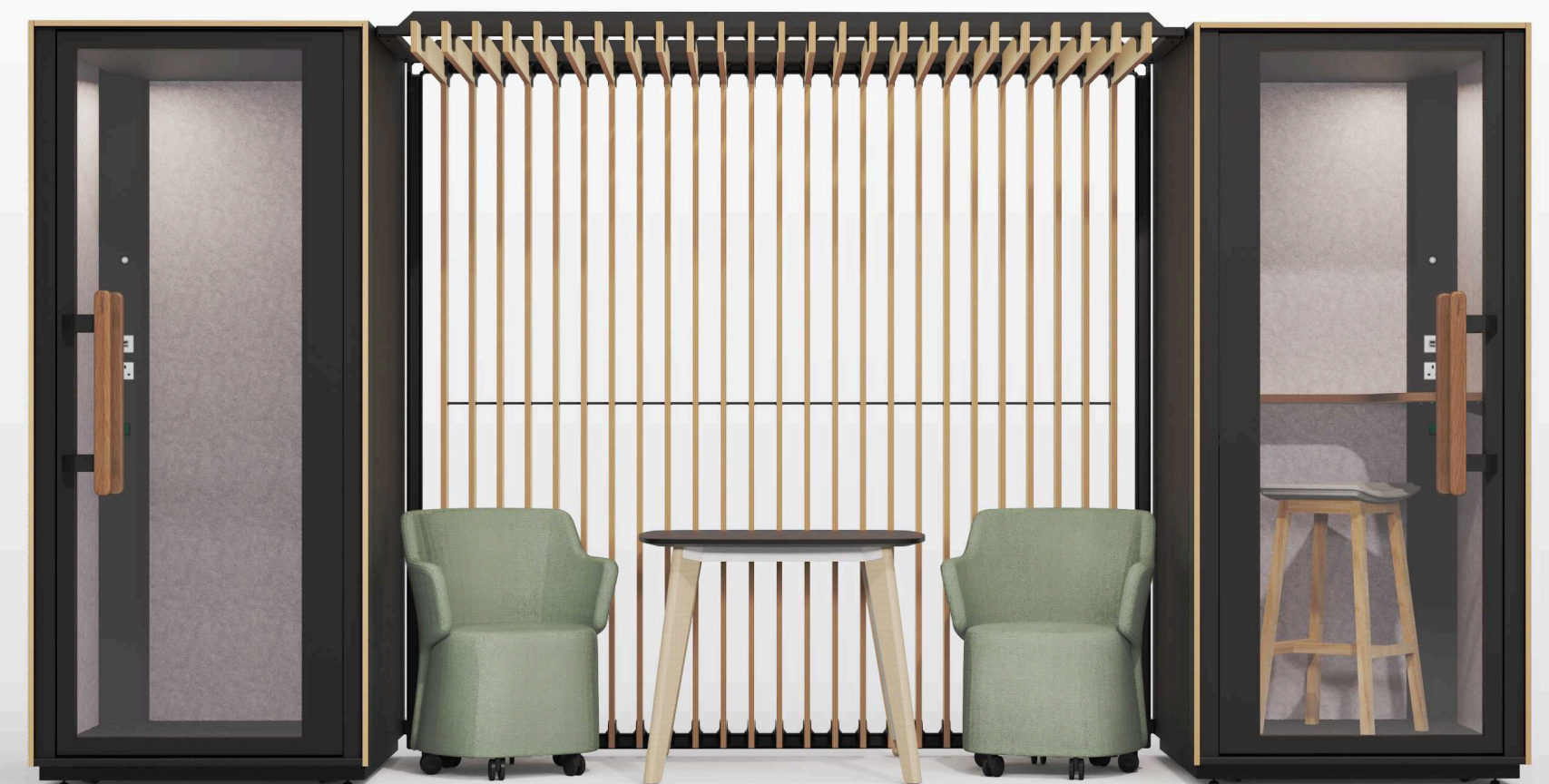

FEATURING SKOMER

## The Canopy

A slated plywood roof that transforms the interconnected space between two phone booths into an intuitive landing point for users to connect and collaborate.



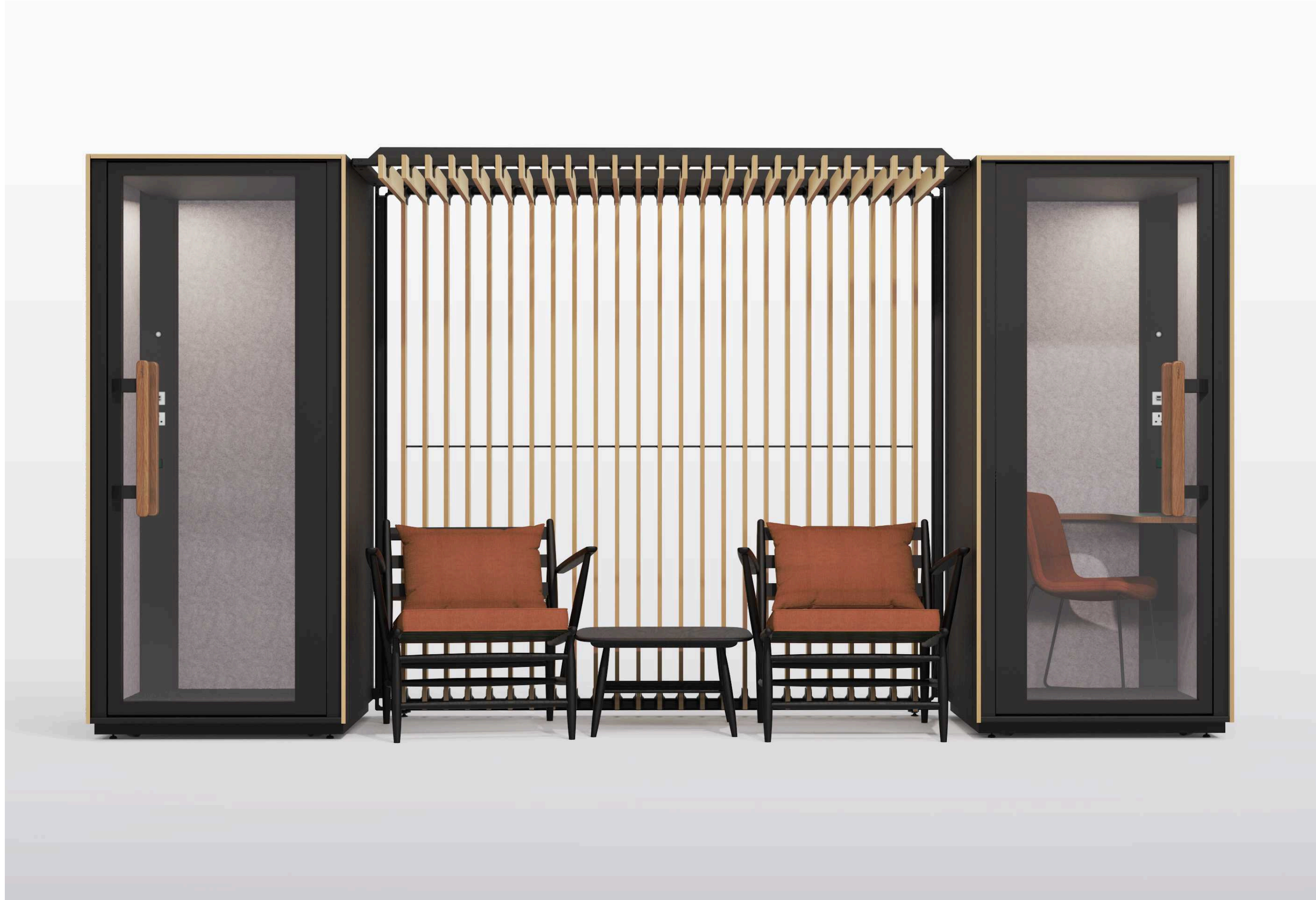

## The Wall

Used together with the Canopy, the Optional Wall utilises the negative space between two phone booths by creating an inviting environment for individuals or groups to gather and engage.



External Shelf – Mild Steel



Textured Black Powder Coated

External Shelf – PET



Grey

Linking Kit – Mild Steel



Textured Black Powder Coated

In-between Canopy,  
In-between Hack –  
Aluminium Extrusion

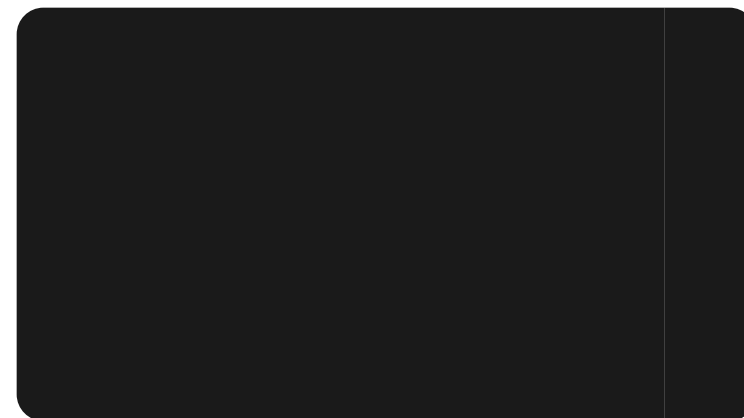

Textured Black Powder Coated

In-between Canopy,  
In-between Hack –  
Mild Steel



Textured Black Powder Coated

In-between Canopy,  
In-between Hack –  
Aluminium Casting



Textured Black Powder Coated

In-between Canopy,  
In-between Hack –  
Wood



Birch Plywood

**Phonebooth dimensions**

H2260 [H89] W1000 [W39]D1000 [D39]

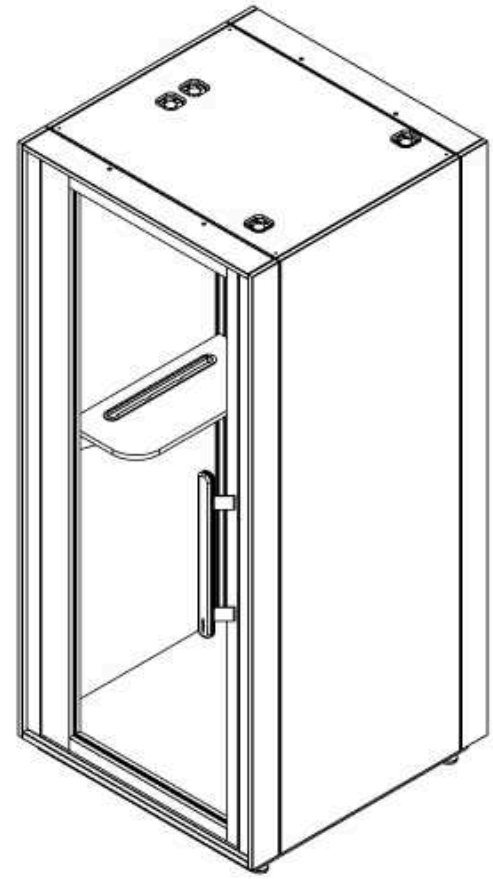

**BMG-LH Phonebooth**  
No kink. Left-hand opening.

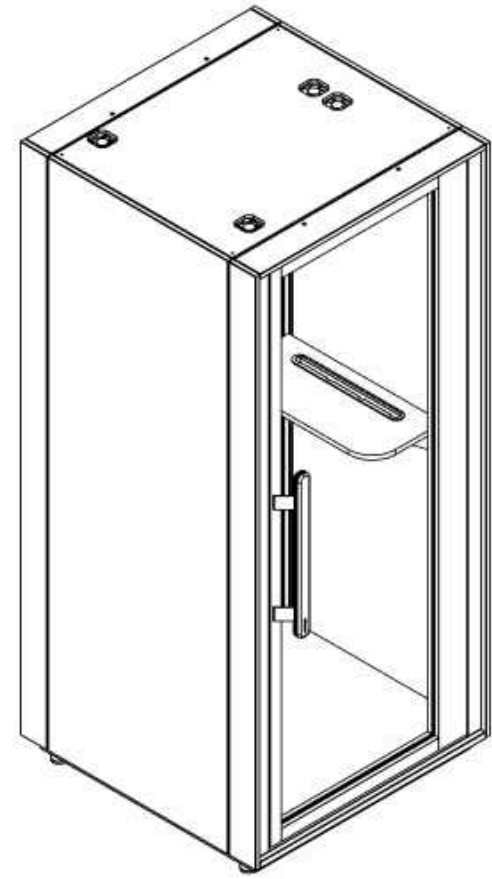

**BMG-RH Phonebooth**  
No kink. Right-hand opening.

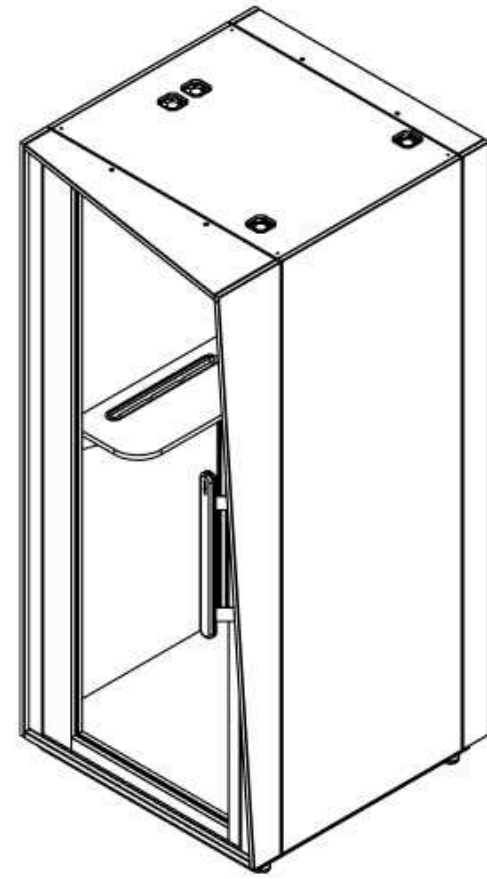

**BMG-LH Phonebooth**  
With kink. Left hand opening.

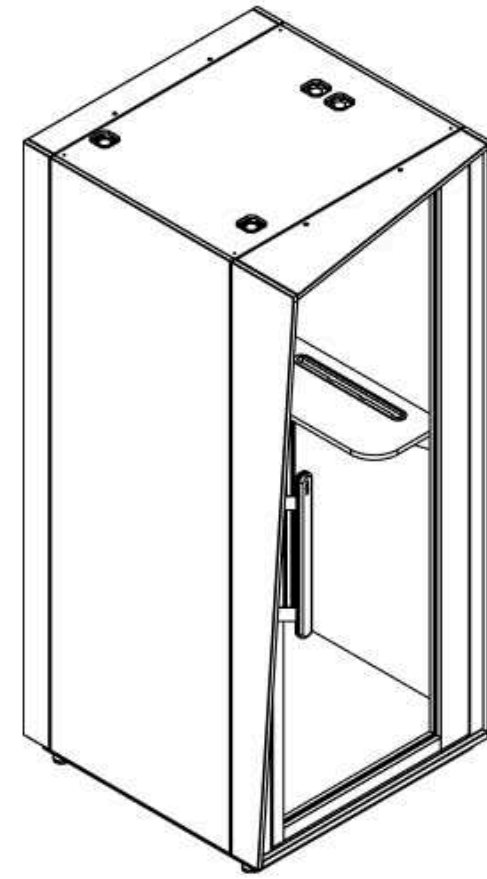

**BMG-RH Phonebooth**  
With kink. Right-hand opening.

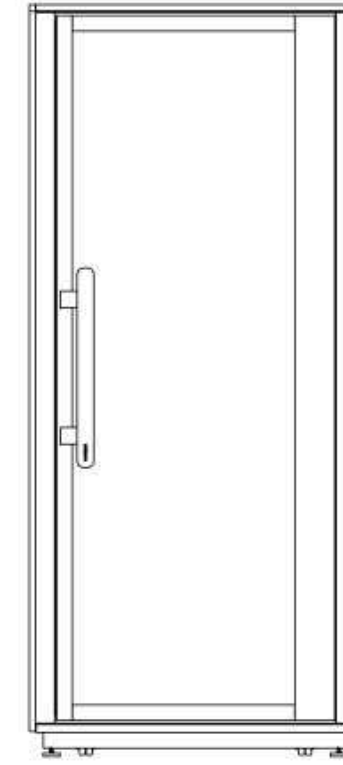

**Front view**  
Right-hand opening.

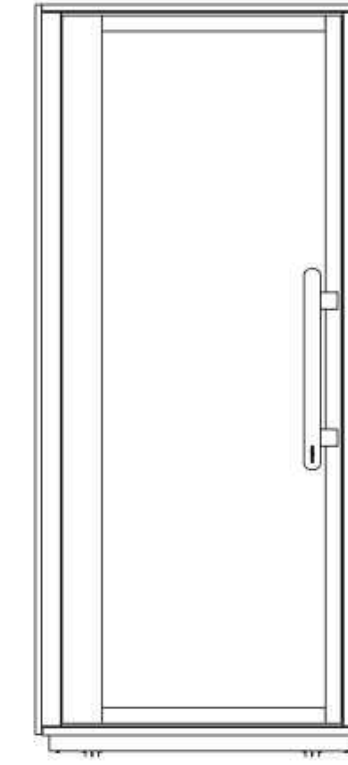

**Front view**  
Left-hand opening.

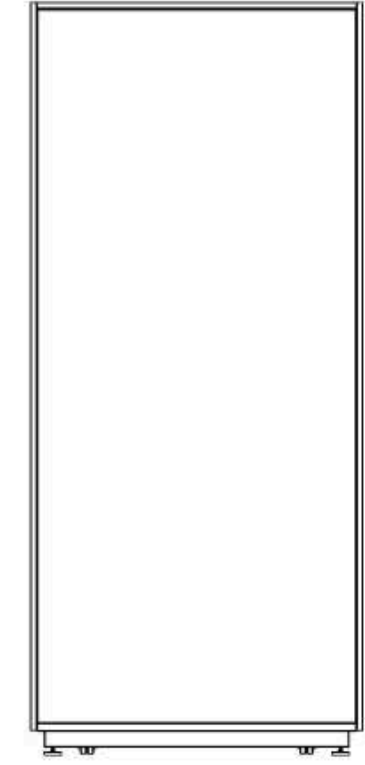

**Rear view**

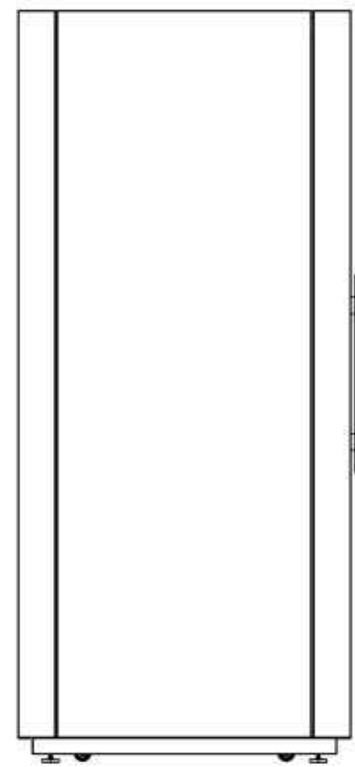

**Side view**  
No kink.

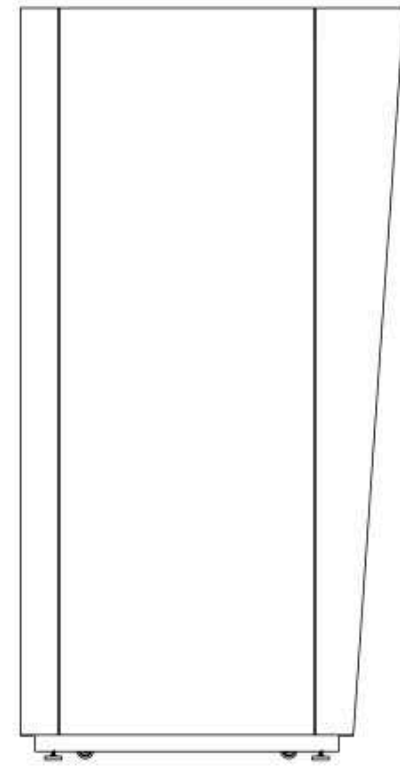

**Side view**  
With kink.

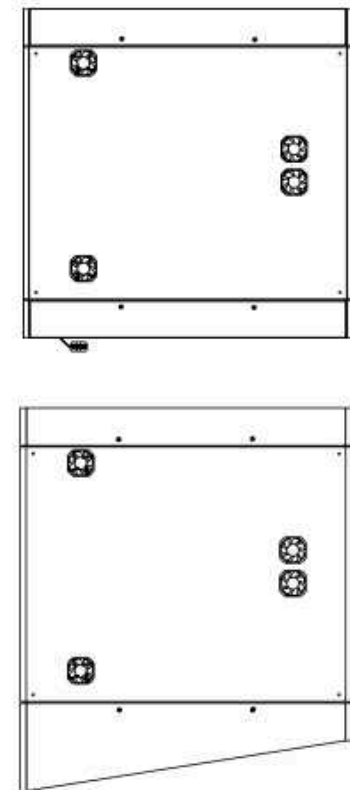

**Plan view**  
4 x ventilation fans.  
Top: no kink  
Bottom: with kink

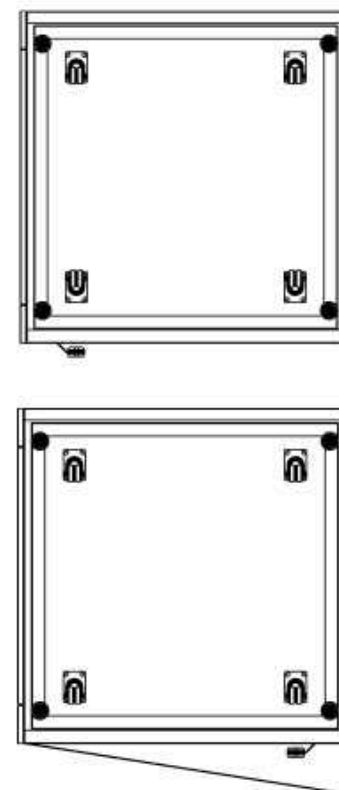

**Base view**  
4 x castors and legs.  
Top: no kink  
Bottom: with kink



**D-shape worksurface**

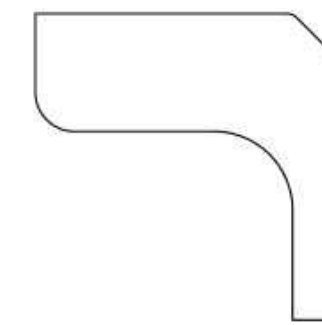

**L-shape worksurface**  
Left-hand opening.

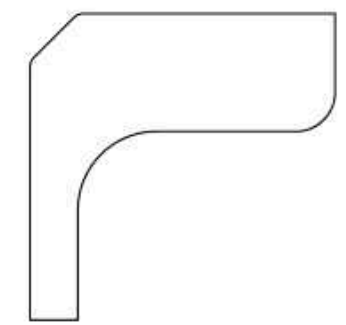

**L-shape worksurface**  
Right-hand opening.

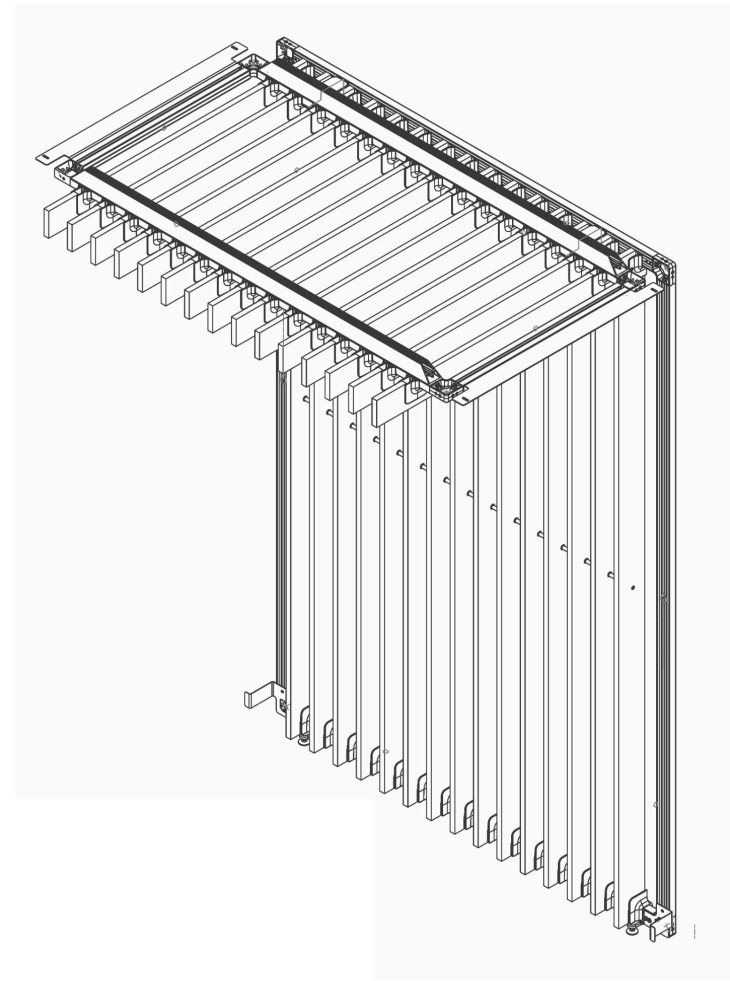

**BMGCON-WL01**  
In-between Hack 1.5m

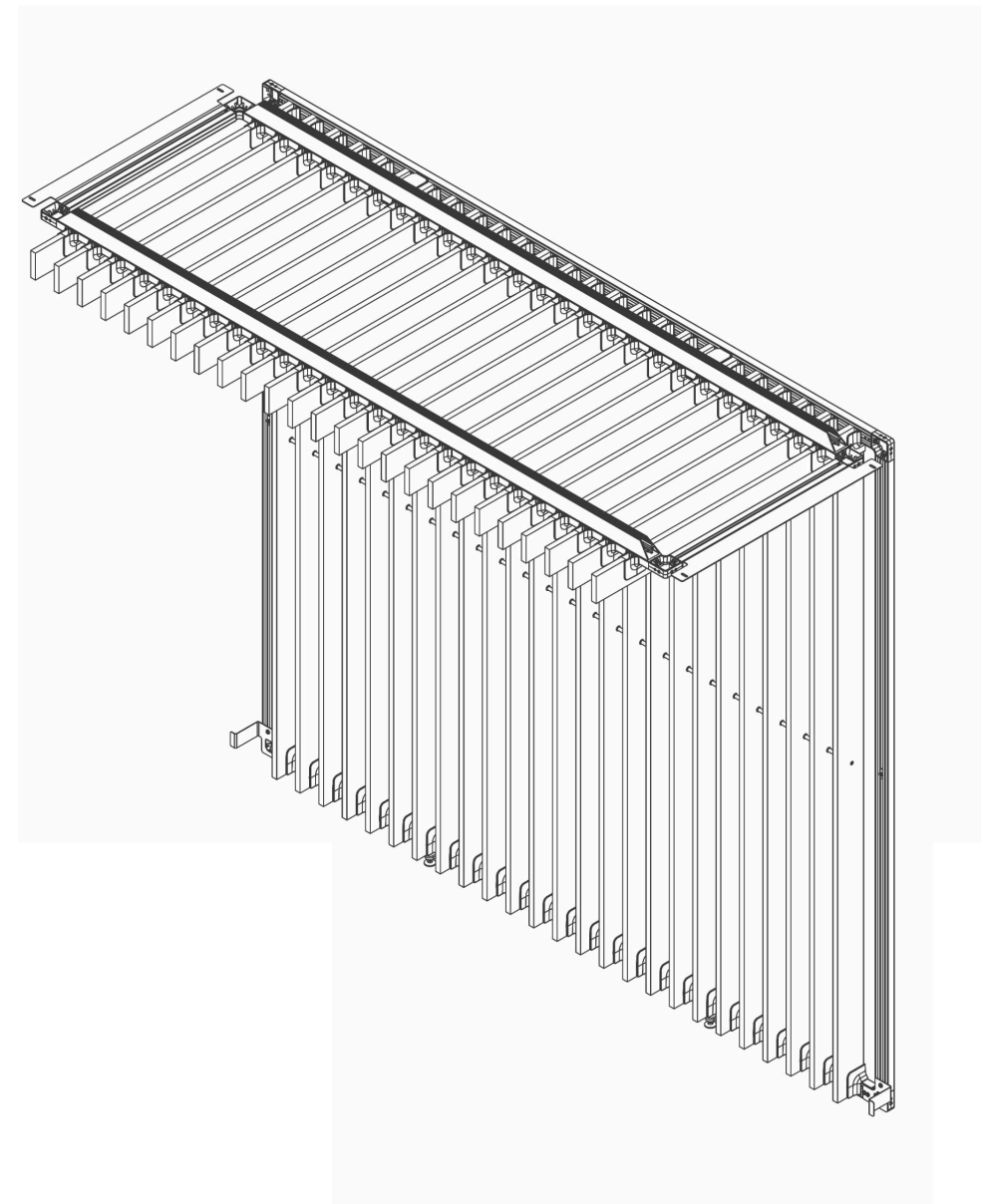

**BMGCON-WL02**  
In-between Hack 2.45m

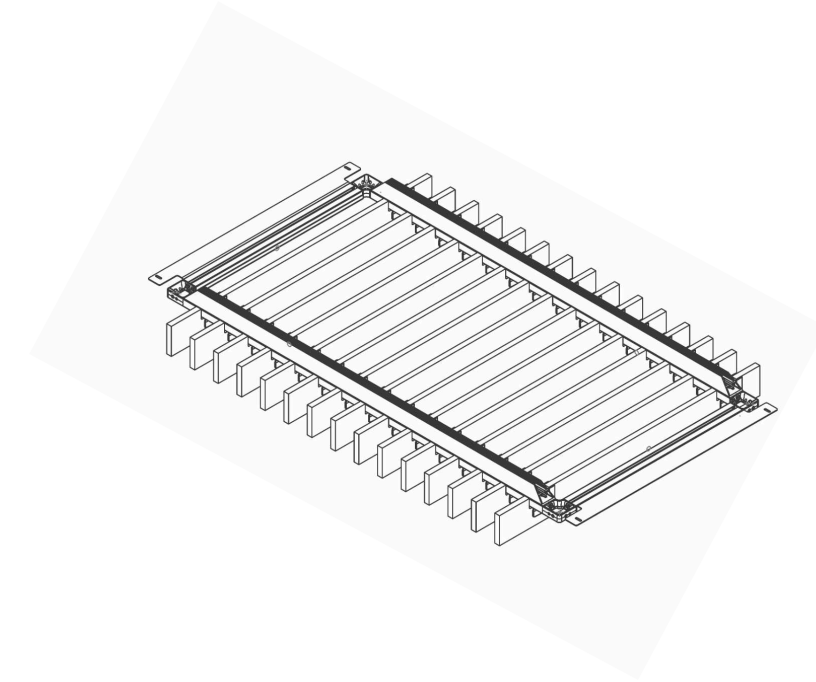

**BMGCON-C01**  
In-between Canopy 1.5m

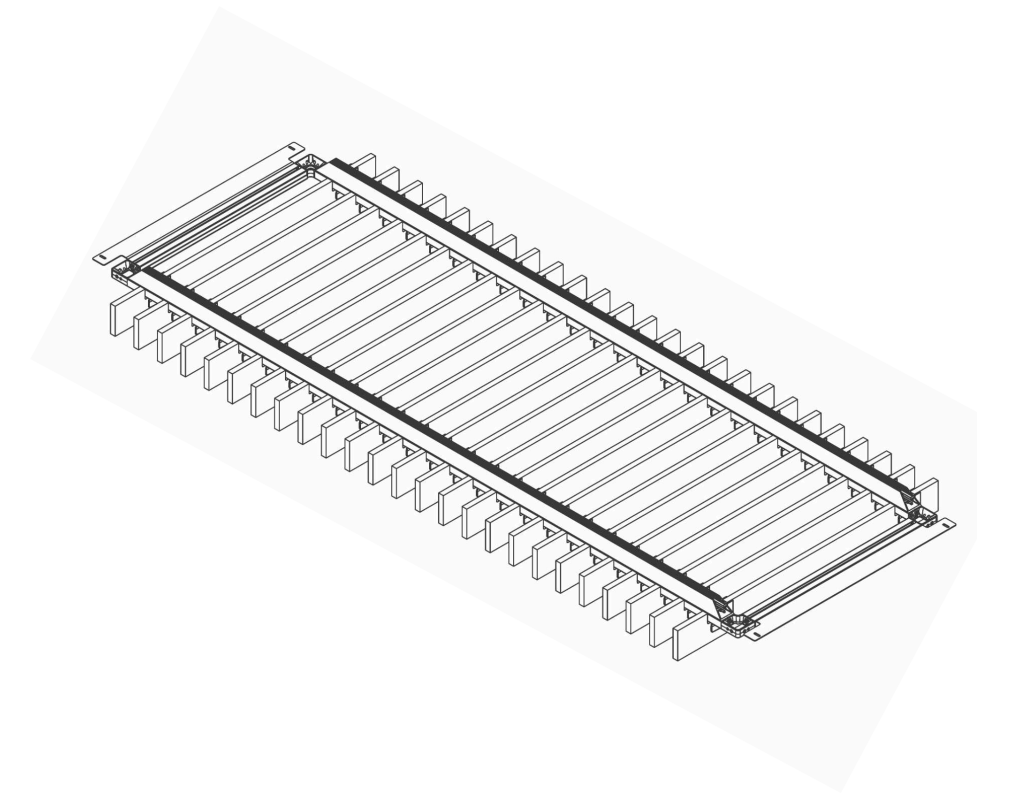

**BMGCON-C02**  
In-between Canopy 2.45m

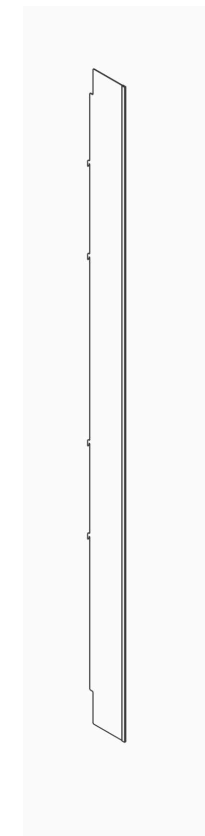

**BMGCON-KIT**  
Linkage Kit

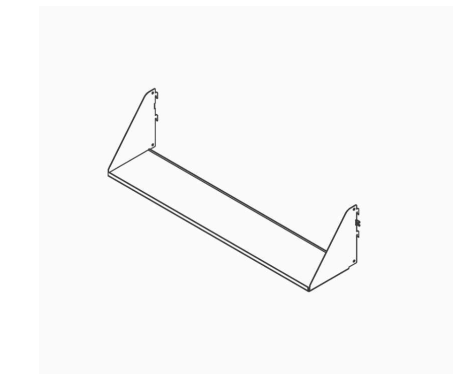

**BMGCON-S01**  
External Shelf

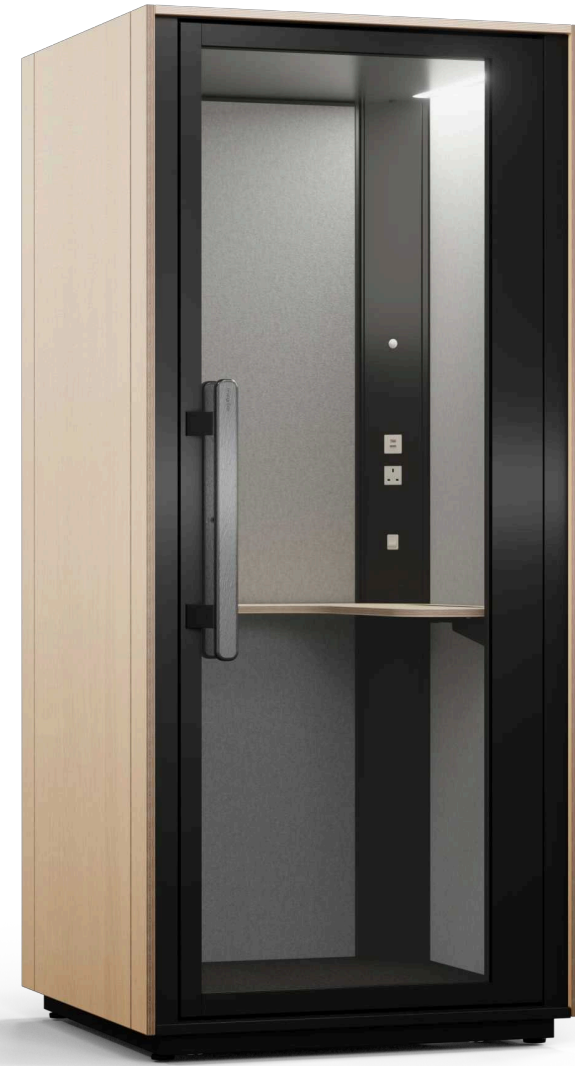

# Be my guest®

**Head Office & Manufacturing Cardiff**

Parc Nantgarw, Cardiff CF15 7QU  
T: +44 (0) 1443 816604  
E: sales@orangebox.com

**London Showroom**

250 City Road, London, EC1V 2AB  
T: +44 (0) 20 7837 9922  
E: showroom@orangebox.com

**Orangebox Smartworking® Huddersfield**

Bates Mill, Colne Road, Huddersfield HD1 3AG  
T: +44 (0) 1484 536400  
E: smartworkinghuddersfield@orangebox.com

BE MY GUEST



# Be my guest<sup>®</sup>

STEP INTO A QUIET RETREAT