



Express Program Specification Guide

Availability

Electronic price list updated with release 204.C (U.S.) and 158.C (Canada), dated June 15, 2026.

All specifications subject to change without notice. Reference the electronic catalog/Hedberg for current pricing.

Transitional products in this specification guide are **maintained for existing customers only** and are likely to be phased out over time. These products are indicated with a . Products that are scheduled to be culled are indicated with an , followed by the last order entry date.

Surface Materials

The surface materials team has announced the launch of the Finish Library, found at www.steelcase.com/finishlibrary/.

► For a list of all trademarks, refer to the last page of this specification guide. © 2026 Steelcase Inc.

Program Overview

2

Statement of Line

4

Seating

Work Chairs	56
Collaborative Seating	97
Lounge Seating	125
Multi-Use Seating	135
Health Seating	153

Furniture

Systems	155
Height-Adjustable Desks	320
Conference and Collaborative Tables	327
Occasional Tables	383
Screens	388
Storage	388
Whiteboards	442

Worktools

Worktools	452
Lighting	455
Power and Cable Management	469
Monitor Arms	475

Surface Materials

480

Style Number Index

484

Program Overview

- The Express program provides a broad selection of our most popular products with expedited manufacturing.
- Products are made-to-order and ship within 7 business days.
- Express is targeted for small and mid-market customers whose business needs require fast delivery. Contract market customers can also take advantage of a broad product offering and faster delivery when undertaking people moves and smaller reconfigurations.

Products Included in Express:

Seating

Work Chairs

- Gesture 442 Series
- Leap 462 Series
- Think 465 Series
- Amia 482 Series
- Steelcase Series 2
- Steelcase Series 1

Collaborative Seating

- SILQ 418 Series
- QiVi 428 Series
- cobī 434 Series
- Node 480 Series
- Collaboration
- Bob
- Bindu Conference Seating
- Bindu Chairs
- Enea Lottus
- Marien152 Conference Seating
- Marien152 Guest Seating
- Massaud Conference Seating
- Montara650 Chairs

Lounge Seating

- Campfire
- Visalia

Multi-Use Seating

- Shortcut
- Move 490 Series
- Max-Stacker III 477 Series

Steelcase Health Seating

- Empath Recliner
- Sorrel

Systems

- Answer
- Universal Systems Worksurfaces and Supports
- Currency

Height-Adjustable Desks

- Migration SE
- Ology

Conference and Collaborative Tables

- Groupwork
- Simple Tables
- Universal Tables
- Verb
- Potrero415
- Potrero415 Light

Occasional Tables

- Campfire
- Await
- Free Stand
- Lagunitas Personal Table

Screens

- Flex Freestanding Screens, Carts, and Stand
- Sarto

Storage

- TS Mobile Pedestals
- Universal Fixed Pedestals
- Universal Mobile Pedestals
- Universal OTC/ITC Bins and Shelves and Accessories
- Universal 1-High/1.5-High/2-High Lateral Files
- Universal Lateral Files
- Universal Storage Cabinets
- Universal Bookcases
- Field Installed Tops
- Ology Common Top
- Adjustable Shelves
- Storage Accessories
- Locks

Parametric Premium Whiteboards and Tackboards

- Premium Parametric
- Sans
- Sans Light
- Verb Personal Whiteboard, Wall Track, and Easel

Worktools

- Adjustable foot rest and CPU holders
- Keyboard track

Lighting

- dash and dash mini LED Lights
- LED Radial Desktop Light
- LED Linear Desktop Light
- LED Intro Task Light
- LED Shelf Light
- LED Linear Shelf Light
- Standard Shelf Light
- Bottomline Shelf Light

Power and Cable Management

- High Capacity Cable Riser
- Vertical Cable Carrier
- Powerstrip Intro
- Powerstrip Plus
- SW_1 Power Pod

Monitor Arms

- CF Intro Single
- CF Intro Dual
- CF Tablet and Laptop Holders
- CF Arm Connector and Brackets

Surface Materials Included in Express:

- 75 vertical surface fabric choices available
 - 114 seating upholstery choices available
 - 57 laminate choices available
 - 25 wood veneer choices available
 - 24 paint choices available
- See *Express Surface Materials*, page 480
- Transitional and select surface materials are not available.

How to Order

- Orders must be specified and transmitted using the SQ5 electronic catalog to ensure orders are processed quickly.
- Use electronic catalog code: SQ5 Steelcase Express
- Orders cannot be changed or canceled.
- The Express program is limited to the models, fabrics, and finishes listed in the SQ5 electronic catalog.
- Consult the specification guide for product details.

Order Maximums

Product Category
All Steelcase Products: 25 units <i>*Exception - Answer: 50 units</i>
All Coalesse Products: 10 units

Order maximums are calculated by product style number. For projects greater than the order maximums, use the standard electronic catalog and work with your Steelcase Solutions Fulfillment Team representative on a delivery schedule.

Splitting large orders into smaller orders to get the Express lead time is not allowed. In the event an order is received that exceeds the maximum style number quantity, the entire order will be moved to standard lead time.

Discounts and Pricing

- Express discount is the same as standard delivery discounts. See your customer's competitive discount authorization (CDA) for pricing details.

Express Planner

Manufacturing, Shipping, and Delivery Time

Express orders are manufactured and shipped within 7 business days.

Example:

Day 0	Day 1-6	Day 7	Day 8+
Steelcase receives complete and clean order before 5:00pm EST.	Order management, materials procurement, order is manufactured.	Order is shipped from manufacturing facility and in transit.	Order is delivered.

Express orders are manufactured within 7 business days and typically deliver within 8–16 business days (weekends, national holidays, and Steelcase holidays are not included). Orders ship through the Steelcase distribution network. Product mix and dealer warehouse scheduled delivery days may impact the actual delivery date. Contact your Steelcase Order Fulfillment Consultant for expedited delivery options. Additional charges may apply.

Statement of Line

Work Chairs

Gesture 442 Series

Specifying
▶ Pages 56–59

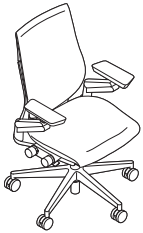

Work Chair with
Wrapped Back



Work Chair

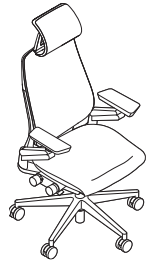

Work Chair with
Headrest

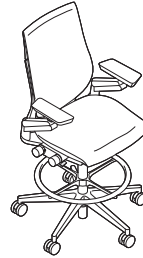

Stool with
Wrapped Back

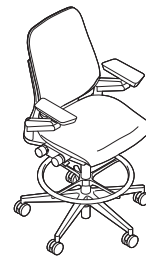

Stool

Leap 462 Series

Specifying
▶ Pages 60–65



Work Chair



Work Chair with
3D Knit Back

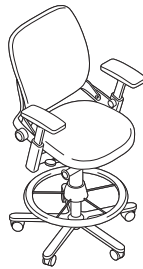

Stool

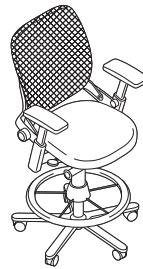

Stool with
3D Knit Back



Plus Work Chair



Plus Work Chair
with 3D Knit Back

Think 465 Series

Specifying
▶ Pages 66–73



Work Chair with
3D Knit Back



Work Chair with
Upholstered Back



Stool with 3D Knit
Back



Stool with
Upholstered Back

Work Chairs, continued

Amia 482 Series

Specifying
▶ Pages 74–81



Work Chair with Upholstery on Seat and Back



Work Chair with 3D Knit on Back, Upholstery on Seat

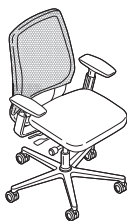

Work Chair with Air Back and 3D Microknit, Upholstery on Seat



Work Chair with Air Back, Upholstery on Seat



Stool with Upholstery on Seat and Back

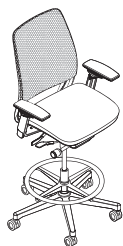

Stool with 3D Knit on Back, Upholstery on Seat

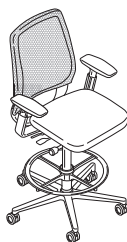

Stool with Air Back and 3D Microknit, Upholstery on Seat



Stool with Air Back, Upholstery on Seat

Steelcase Series 2

Specifying
▶ Pages 82–93



Work Chair with Air Back, Upholstery on Seat and Back



Work Chair with Air Back and 3D Microknit, Upholstery on Seat



Work Chair with Air Back, Upholstery on Seat



Stool with Air Back, Upholstery on Seat and Back

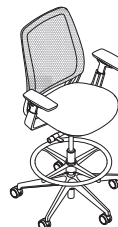

Stool with Air Back and 3D Microknit, Upholstery on Seat



Stool with Air Back, Upholstery on Seat

Steelcase Series 1

Specifying
▶ Pages 94–96



Work Chair with 3D MicroKnit Back



Stool with 3D MicroKnit Back

Collaborative Seating

SILQ 418 Series

Specifying
▶ Pages 97–98



SILQ Collaborative
Chair with Arms



SILQ Collaborative
Chair Armless

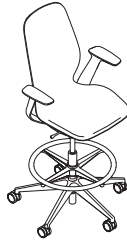

SILQ Collaborative
Stool with Arms

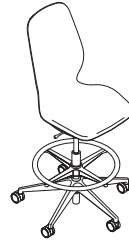

SILQ Collaborative
Stool Armless

QiVi 428 Series

Specifying
▶ Pages 99–101



Collaborative Chair
with Arms

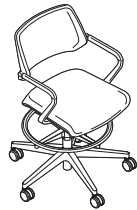

Collaborative Stool

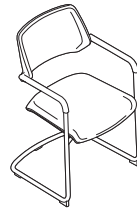

Sled-Base Chair

cobi 434 Series

Specifying
▶ Pages 102–103

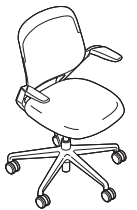

Collaborative
Chair with Arms



Collaborative
Chair without Arms

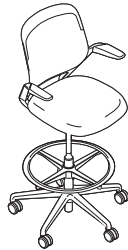

Collaborative
Stool with Arms

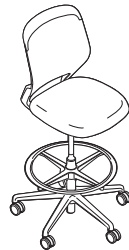

Collaborative
Stool without Arms

Collaborative Seating, continued

Node 480 Series

Specifying
▶ Pages 104–109



Mid-Back Chair



Mid-Back Chair with
Personal Workspace



Mid-Back Chair with
Swivel-Base



Mid-Back Chair with
Swivel-Base and Personal
Workspace



Mid-Back Stool with
Swivel-Base



High-Back
Chair

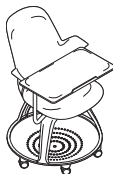

High-Back Chair with
Personal Workspace



High-Back Chair
with Swivel-Base



High-Back Chair with
Swivel-Base and Personal
Workspace



High-Back Stool
with Swivel-Base

Collaboration

Specifying
▶ Page 110



Open

Tip: All Collaboration guest chairs are available with plain wood arms.

Collaborative Seating, continued

Bob Lounge Chairs

Specifying
▶ Pages 111–112



Lounge Chair



Lounge Chair with
Headrest

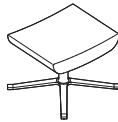

Ottoman

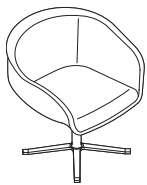

Guest Chair

Bindu Conference Seating

Specifying
▶ Pages 113–114



Mid-Back Conference
Chair



Low-Back Chair

Collaborative Seating, continued

Enea Lottus Chairs

Specifying
▶ Pages 115–116

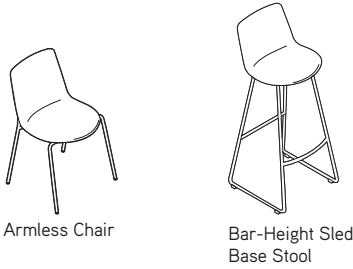

Armless Chair

Bar-Height Sled Base Stool

Marien152 Conference Seating

Specifying
▶ Page 117



Marien152 Guest Seating

Specifying
▶ Pages 118–119

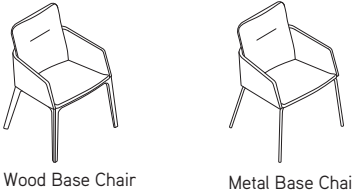

Wood Base Chair

Metal Base Chair

Massaud Conference Seating

Specifying
▶ Pages 120–121



Mid-Back Conference Chair with Loop Arm

Low-Back Conference Chair with Integrated Arm

Montara650 Chairs

Specifying
▶ Pages 122–123



Wood Shell, Wood Shell with Upholstered Seat, Wood Shell with $\frac{3}{4}$ Upholstery, and Fully Upholstered

Montara650 Stools

Specifying
▶ Page 124



Counter-Height or Bar-Height Stool: Wood Shell, Wood Shell with Upholstered Seat, and Fully Upholstered

Lounge Seating

Campfire

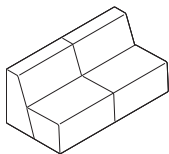

Big Lounge
Specifying
▶ Page 125

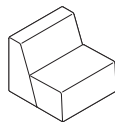

Half Lounge
Specifying
▶ Page 127

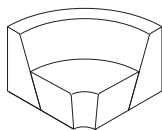

90° Inside Corner Lounge
Specifying
▶ Pages 129–130

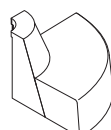

90° Outside Corner Lounge
Specifying
▶ Pages 129–130



60° Inside Corner Lounge
Specifying
▶ Pages 131–132

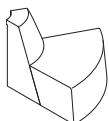

60° Outside Corner Lounge
Specifying
▶ Pages 131–132

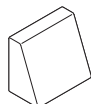

Wedge
Specifying
▶ Page 133

Visalia Lounge Seating

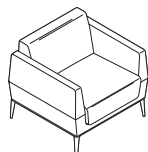

Lounge Chair
Specifying
▶ Page 134

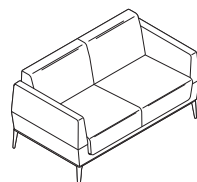

2-Seat Lounge
Specifying
▶ Page 134

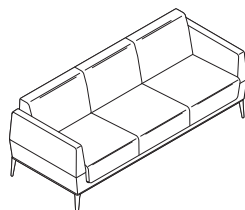

3-Seat Lounge
Specifying
▶ Page 134

Multi-Use Seating

Shortcut

Specifying
▶ Pages 135–141



Multi-Purpose
Chair

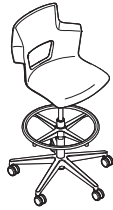

Multi-Purpose
Stool



Multi-Purpose
Chair with Personal
Workspace



X Base Chair



X Base Stool

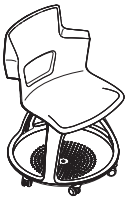

Chair with Tripod
Base



Chair with Tripod
Base and Personal
Workspace

Simple

Specifying
▶ Pages 142–147



Chair

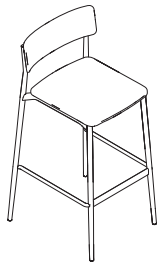

Stool



Seat Cushion



Back Cushion

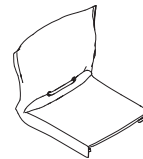

Relaxed Slipcover

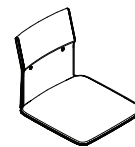

Tailored Slipcover

Multi-Use Seating, continued

Move 490 Series

Specifying
▶ Pages 148–151



Multi-Use Chair
without Arms



Multi-Use Chair
without Arms with
Casters



Multi-Use Chair
with Arms



Multi-Use Chair
with Arms and
Casters

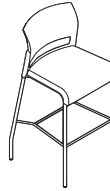

Stool without Arms



Stool without Arms
with Casters

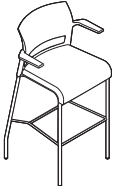

Stool with Arms



Stool with Arms
with Casters

Max-Stacker III 477 Series

Specifying
▶ Page 152



Stackable Chair

Health Seating

Empath Recliner

Specifying
▶ Page 153

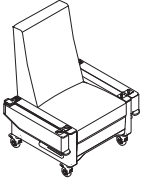

With Dual Flip-Down Arms*

Sorrel

Specifying
▶ Page 154

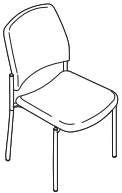

18"W Stacking
Chair Without Arms*

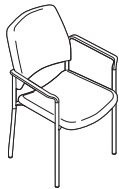

18"W Stacking
Chair With Arms*

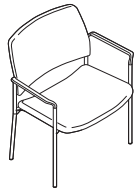

Bariatric Chair*

*Available with straight or wallsaver legs.

Answer



Specifying
▶ Pages 155–159,
174

Base Junctions—Thin Trim

	In-Line Base Junctions	L-Base Junctions	T-Base Junctions	X-Base Junctions	End-of-Run Base Junctions	V-Base Junctions	Y-Base Junctions	Wall-Start Junctions
30"	●	●	●	●	●	●	●	●
36"	●	●	●	●	●	●	●	●
42"	●	●	●	●	●	●	●	●
48"	●	●	●	●	●	●	●	●
54"	●	●	●	●	●	●	●	●
66"	●	●	●	●	●	●	●	●
78"	●	●	●	●	●	●	●	●



Specifying
▶ Pages 160–172

Change-of-Height Junctions—Thin Trim

In-Line Change-of-Height Junction	L Change-of-Height Junction	T Change-of-Height Junction	X Change-of-Height Junction	V Change-of-Height Junction	Y Change-of-Height Junction
●	●	●	●	●	●

Note: Accommodates most panel heights and combinations.

Answer, continued



Specifying
▶ Pages 176–178

Stacking Junctions—Thin Trim

	Stacking In-Line Junctions	Stacking L Junctions	Stacking T Junctions	Stacking X Junctions	Stacking End-of-Run Junctions	Stacking V Junctions	Stacking Y Junctions	Wall-Start Junction
12"	●	●	●	●	●	●	●	●
18"	●	●	●	●	●	●	●	●
24"	●	●	●	●	●	●	●	●

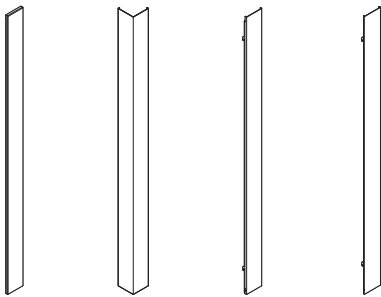

Specifying
▶ Pages 182–184

Vertical Trim—Thin Trim

	End-of-Run Vertical Trim	L Vertical Trim	T Vertical Trim	V Vertical Trim
30"	●	●	●	●
36"	●	●	●	●
42"	●	●	●	●
48"	●	●	●	●
54"	●	●	●	●
60"	●	●	●	●
66"	●	●	●	●
72"	●	●	●	●
78"	●	●	●	●
84"	●	●	●	●
90"	●	●	●	●



Specifying
▶ Pages 185–187

Change-of-Height—Thin Trim

	End-of-Run Change-of-Height	L Corner Change-of-Height	T Corner Change-of-Height	120° Corner Change-of-Height	V Change-of-Height
12"	●	●	●	●	●
18"	●	●	●	●	●
24"	●	●	●	●	●
30"	●	●	●	●	●
36"	●	●	●	●	●

Answer, continued



Specifying
▶ Page 188



Specifying
▶ Page 188

Junction Posts

30"	36"	42"	48"	54"	66"	78"
●	●	●	●	●	●	●

Junction Blocks

90° Corner	120° Corner
●	●



Specifying
▶ Page 189



Specifying
▶ Pages 189–190

Inside Corner Light Seals

54"	66"	78"
●	●	●

Junction Caps

90° Corner Junction Cap	120° Corner Junction Cap	90° Change- of-Height Junction Cap	Junction Cap Corner Aligner
●	●	●	●

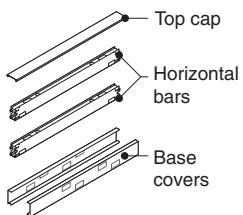

Specifying
▶ Page 192

Base Horizontal Frame Packages—Thin Trim

18"	24"	30"	36"	42"	48"	60"	72"
●	●	●	●	●	●	●	●

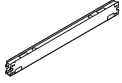
Answer, continued

Specifying
▶ Page 194

Stacking Horizontal Frame Packages

18"W	24"W	30"W	36"W	42"W	48"W	60"W	72"W
●	●	●	●	●	●	●	●

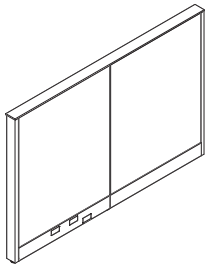

Specifying
▶ Page 195

Spanning Top Caps—Thin Trim

36"W	42"W	48"W	60"W	72"W	78"W	84"W	90"W	96"W
●	●	●	●	●	●	●	●	●

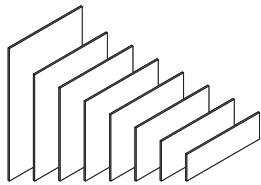

Specifying
▶ Page 196

Tackable Acoustical Fabric-Covered Panel Skins

	18"W	24"W	30"W	36"W	42"W	48"W	60"W	72"W
12"H	●	●	●	●	●	●	●	●
18"H	●	●	●	●	●	●	●	●
24"H	●F	●F	●F	●F	●F	●F	●F	●F
30"H	●F	●F	●F	●F	●F	●F	●F	●F
36"H	●F	●F	●F	●F	●F	●F	●F	●F
42"H	●F	●F	●F	●F	●F	●F	●F	●F
48"H	●F	●F	●F	●F	●F	●F	●F	●F
60"H	●F	●F	●F	●F	●F	●F	●F	●

F = To the floor sizes

Answer, continued

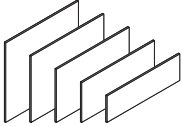

Specifying
▶ Page 198

Steel Panel Skins

	18"W	24"W	30"W	36"W	42"W	48"W	60"W	72"W
12"H	●	●	●	●	●	●	●	●
18"H	●	●	●	●	●	●	●	●
24"H	●F	●F	●F	●F	●F	●F	●F	●F
30"H	●F	●F	●F	●F	●F	●F	●F	●F
36"H	●F	●F	●F	●F	●F	●F	●F	●F

F = To the floor sizes

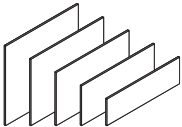

Specifying
▶ Page 202

Markerboard Skins

	18"W	24"W	30"W	36"W	42"W	48"W	60"W	72"W
12"H	●	●	●	●	●	●	●	●
18"H	●	●	●	●	●	●	●	●
24"H	●	●	●	●	●	●	●	●
30"H	●	●	●	●	●	●	●	●
36"H	●	●	●	●	●	●	●	●

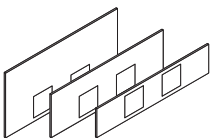

Specifying
▶ Page 204

Steel Technology Skins

	24"W	30"W	36"W	42"W	48"W	60"W	72"W
6"H	●	●	●	●	●	●	●
12"H	●	●	●	●	●	●	●
18"H	●	●	●	●	●	●	●

Tip: Technology skins are available with fabric-covered option.

Answer, continued

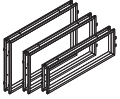

Specifying
▶ Page 207

Glass Windows—Single Pane

	24"W	30"W	36"W	42"W	48"W	60"W	72"W	78"W	84"W	90"W	96"W
12"H	●	●	●	●	●	●	●	●	●	●	●
18"H	●	●	●	●	●	●	●	●	●	●	●
24"H	●	●	●	●	●	●	●	●	●	●	●

Interface Products

The interface is the point at which the utilities within a panel connect to a building's power and communication network. All power components are field installed.

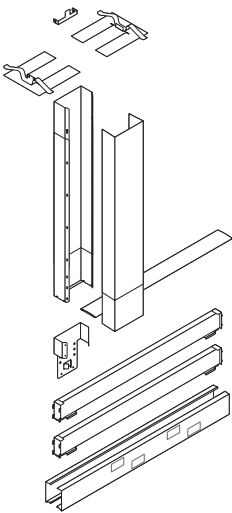

Ceiling-Access Lay-In Utility Package
Specifying
▶ Page 180

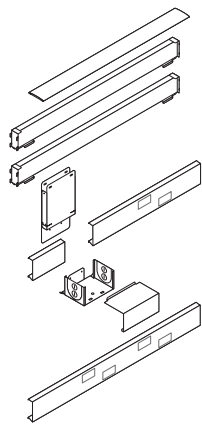

Floor-Access Lay-In Utility Package
Specifying
▶ Page 181



Utility Pole—Thin Trim
Specifying
▶ Page 179

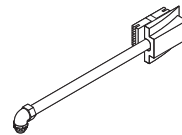

Base Power Infeed
Specifying
▶ Page 213

Answer, continued

Distribution Products

Distribution refers to the way that power and communication networks are routed through a panel.

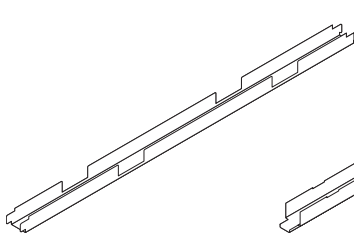

Cable Tray
Specifying
▶ Page 209

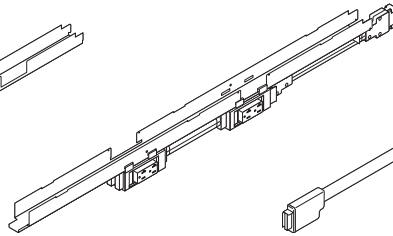

Powerkit
Specifying
▶ Page 210

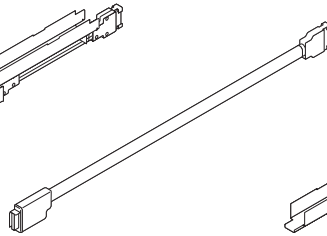

Pass-Through Powerkit
Specifying
▶ Page 211

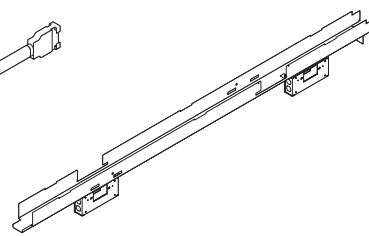

Hardwired Powerkits
Specifying
▶ Page 214

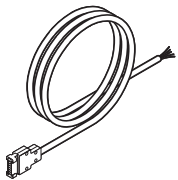

Multipurpose Power Infeed
Specifying
▶ Page 215

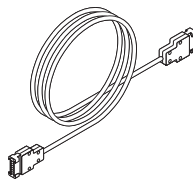

Modular Harness
Specifying
▶ Page 216

Access Products

Access to power and communication networks is accommodated by power receptacles and communication outlets installed in a panel.



Duplex Receptacles
Specifying
▶ Page 212



Faceplate
Specifying
▶ Page 213

Universal Systems Worksurfaces

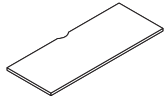

Specifying
▶ Page 218

Straight Worksurfaces

With 1/2" Cord Drop

18 3/8"	24" 441 sq. in.	30" 550 sq. in.	36" 661 sq. in.	42" 771 sq. in.	48" 881 sq. in.	54" 991 sq. in.	60" 1102 sq. in.	66" 1212 sq. in.	72" 1323 sq. in.
18 3/8"	78" 1433 sq. in.		84" 1543 sq. in.		90" 1653 sq. in.		96" 1764 sq. in.		
23 1/2"	24" 563 sq. in.	30" 704 sq. in.	36" 845 sq. in.	42" 986 sq. in.	48" 1127 sq. in.	54" 1268 sq. in.	60" 1409 sq. in.	66" 1550 sq. in.	72" 1691 sq. in.
23 1/2"	78" 1832 sq. in.		84" 1973 sq. in.		90" 2114 sq. in.		96" 2255 sq. in.		
29 1/2"	24" 707 sq. in.	30" 884 sq. in.	36" 1061 sq. in.	42" 1238 sq. in.	48" 1415 sq. in.	54" 1592 sq. in.	60" 1769 sq. in.	66" 1946 sq. in.	72" 2123 sq. in.
35 1/2"	60" 2156 sq. in.		66" 2371 sq. in.		72" 2587 sq. in.				

Tip: Worksurfaces greater than 30"D can only be used in free-standing applications.

Tip: Common dimensions displayed, parametric dimensions available in depths from 18" to 36" and widths from 18" to 96" in 1/16" increments both depth and width.

Universal Systems Worksurfaces, continued

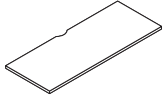

Specifying
▶ Page 218

Straight Worksurfaces, continued

With Full Depth

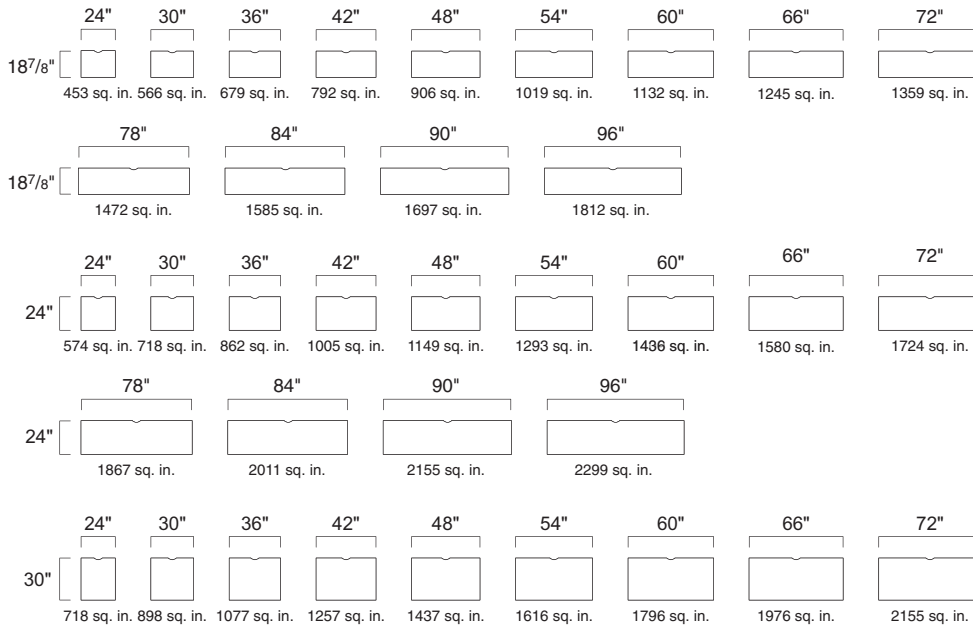

Tip: Common dimensions displayed, parametric dimensions available in depths from 18" to 36" and widths from 18" to 96" in 1/16" increments both depth and width.

Currency

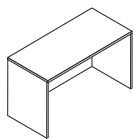

Specifying
▶ Page 230

Desk Shells

	36"W	42"W	48"W	54"W	60"W	66"W	72"W	84"W	96"W
18 ⁷ / ₈ "D	●	●	●	●	●	●	●		
24"D	●	●	●	●	●	●	●	●	●
30"D	●	●	●	●	●	●	●		

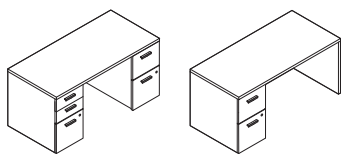

Specifying
▶ Page 230

Desks with Pedestals

	60"W	66"W	72"W
24"D	●	●	●
30"D	●	●	●

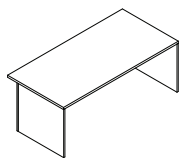

Specifying
▶ Page 234

Desk Shell with 6" Overhang

	36"W	42"W	48"W	54"W	60"W	66"W	72"W	84"W	96"W
36"D	●	●	●	●	●	●	●	●	●

Currency, continued

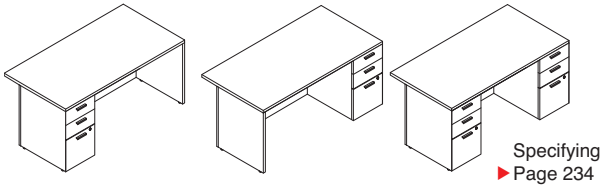

Desk with 6" Overhang and Pedestals

	60"W	66"W	72"W
36"D	●	●	●



Bow Front Desk Shells

	66"W	72"W	84"W	96"W
36"D	●	●	●	●
42"D	●	●	●	●

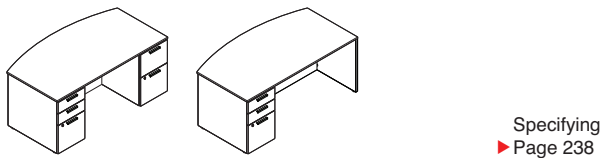

Bow Front Desks with Pedestals

	66"W	72"W
36"D	●	●
42"D	●	●

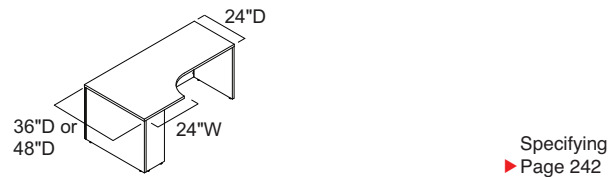

Extended Curved Corner Desk Shells

	66"W	72"W
36"D	●	●
48"D	●	●

Tip: Right-handed application shown. Left-handed application is also available.



Curved Corner Desk Shells

	42"W
24"D	●

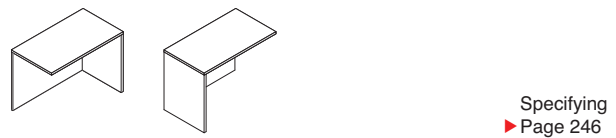

Return Shells

	36"W	42"W	48"W
18 ⁷ / ₈ "D	●	●	●
24"D	●	●	●

Currency, continued

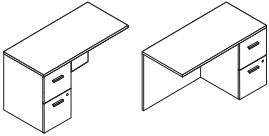

Specifying
▶ Page 246

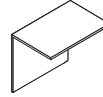

Specifying
▶ Page 249

Returns with Pedestal

	42"W	48"W
24"D	●	●

Bridges

	36"W	42"W	48"W
18 ⁷ / ₈ "D	●	●	●
24"D	●	●	●

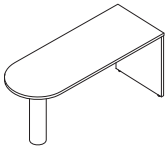

Specifying
▶ Page 250

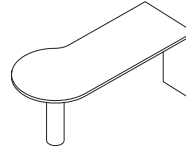

Specifying
▶ Page 250

D-Shape Worksurfaces

	48"W – 78"W
30"D – 36"D	●

P-Shape Worksurfaces

	54"W – 72"W
24"D – 36"D	●

Tip: Left-handed application shown. Right-handed application is also available.

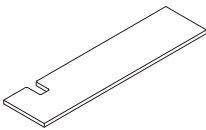

Specifying
▶ Page 252

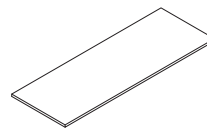

Specifying
▶ Page 254

Parametric Common Tops HAD Application

	30"W – 96"W
18 ⁷ / ₈ "D – 24"D	●

Tip: Right-handed application shown. Left-handed application is also available.
Tip: Parametric depth (18⁷/₈"D–24"D) is available in 1/16" increments.
Tip: Parametric width (30"W–96"W) is available in 1/16" increments.

Parametric Common Tops/Worksurfaces

	15"W – 96"W
12"D – 36"D	●

Tip: Parametric width (15"W–96"W) is available in 1/16" increments.
Tip: Parametric depth (12"D–36"D) is available in 1/16" increments.

Currency, continued

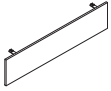

Specifying
▶ Page 256

Modesty Panel

24"W – 60"W	
13 ³ / ₄ "H	●

Tip: Parametric width (24"W–60"W) is available in 1/16" increments.

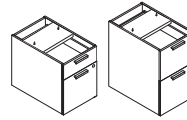

Specifying
▶ Page 258

1.5-High and Two-High Fixed Pedestals

15 ³ / ₄ "W	
21 ³ / ₈ "H	●
27 ⁵ / ₁₆ "H	●

Tip: Available in 18⁷/₈"D and 24"D for 1.5-High and in 18⁷/₈"D, 24"D, and 30"D for Two-High.

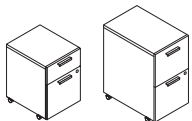

Specifying
▶ Page 262

Mobile Pedestals

15 ³ / ₄ "W	
23 ² / ₃ "H	●
27 ³ / ₃₂ "H	●

Tip: Available in 18⁷/₈"D and 22"D for 1.5-High and in 22"D for Two-High.
Tip: Heights represent mobile pedestal without cushion top. When adding a cushion top, expect an additional 1¹/₂" height.

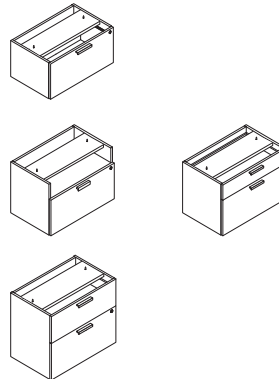

Specifying
▶ Page 264

One-High, 1.5-High, and Two-High Lateral Files

		30"W	36"W
One-High	15 ³ / ₈ "H	●	●
1.5-High	21 ³ / ₈ "H	●	●
Two-High	27 ⁵ / ₁₆ "H	●	●

Currency, continued

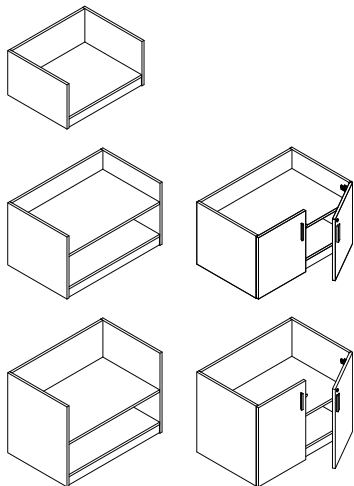

Specifying
▶ Page 266

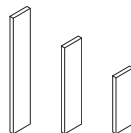

Specifying
▶ Page 269

One-High, 1.5-High, and Two-High Lower Storage

		30"W	36"W	42"W
One-High	15 ³ / ₈ "H	●	●	●
1.5-High	21 ³ / ₈ "H	●	●	●
Two-High	27 ⁵ / ₁₆ "H	●	●	●

One-High, 1.5-High, and Two-High Storage Filler Panels

	5 ¹ / ₈ "W
15 ³ / ₈ "H	●
21 ³ / ₈ "H	●
27 ³ / ₈ "H	●

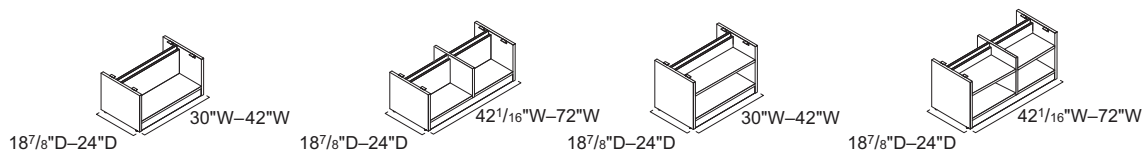

Specifying
▶ Page 270

One-High and 1.5-High Storage for Ology, Migration SE, and Slim Leg HAD Applications

	30"W	36"W	42"W	48"W	60"W	72"W
15 ³ / ₈ "H	●	●	●	●	●	●
21 ³ / ₈ "H	●	●	●	●	●	●

Credenza, continued

1.5-High

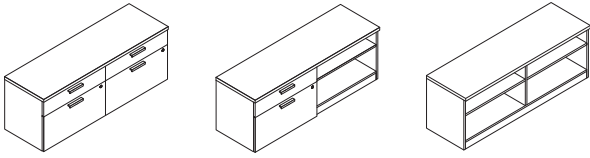

Two-High

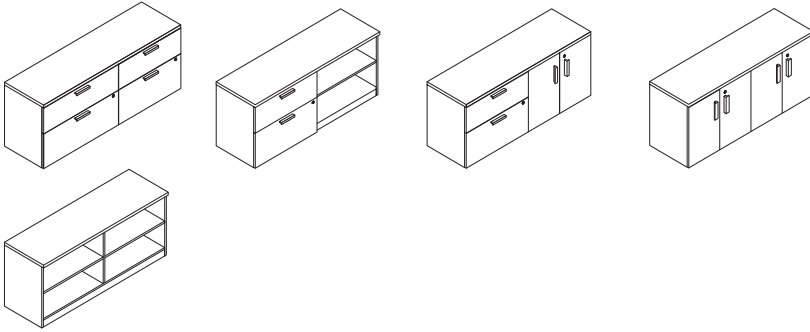

Specifying
▶ Pages 272–276

1.5-High and Two-High Credenza Storage

	42"W	48"W	60"W	66"W	72"W
18 ⁷ / ₈ "D	●	●	●	●	●
24"D	●	●	●	●	●

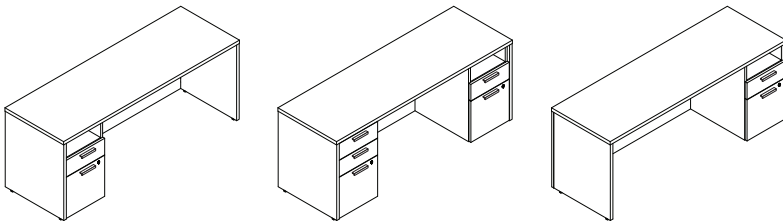

Specifying
▶ Page 280

Two-High Credenza Storage with Kneespace

	60"W	66"W	72"W
18 ⁷ / ₈ "D	●	●	●
24"D	●	●	●

Currency, continued

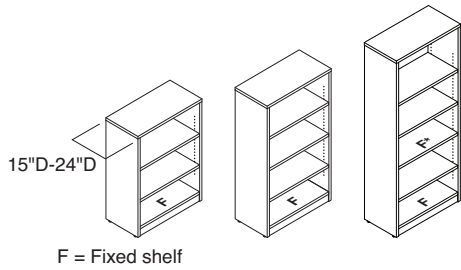

F = Fixed shelf

Specifying
▶ Page 282

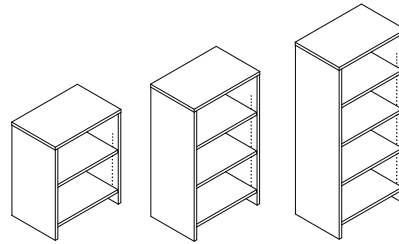

Specifying
▶ Page 286

Bookcases

	24"W	30"W	36"W
41 ³ / ₄ "H	●	●	●
47 ¹⁵ / ₁₆ "H	●	●	●
54 ¹ / ₈ "H	●	●	●
66 ¹ / ₂ "H	●	●	●
72"H	●	●	●
78"H	●	●	●
84"H	●	●	●

Stacking Bookcases

Application Height	24"W	30"W	36"W
41 ³ / ₄ "H	●	●	●
47 ¹⁵ / ₁₆ "H	●	●	●
54 ¹ / ₈ "H	●	●	●
66 ¹ / ₂ "H	●	●	●
72"H	●	●	●
78"H	●	●	●
84"H	●	●	●

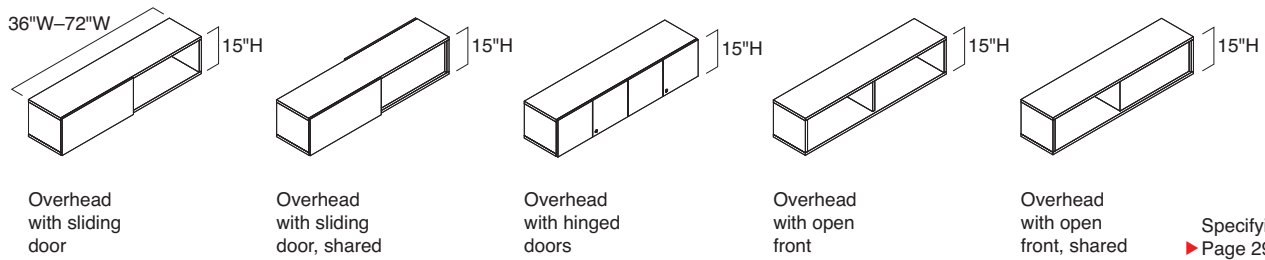

Specifying
▶ Page 294

Overheads with Hinged Doors, Sliding Doors, and No Doors

	36"W	42"W	48"W	54"W	60"W	66"W	72"W
15"D without doors	●	●	●	●	●	●	●
16"D with doors	●	●	●	●	●	●	●

Currency, continued

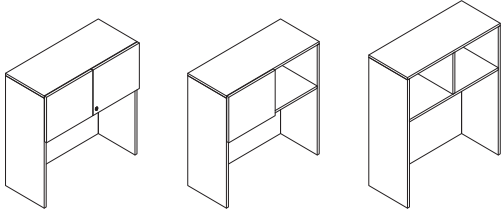

Specifying
▶ Page 298

Stacking Overheads with Hinged Doors, Sliding Doors, or No Doors

	36"W	42"W	48"W	54"W	60"W	66"W	72"W
15"D without doors	●	●	●	●	●	●	●
16"D with doors	●	●	●	●	●	●	●

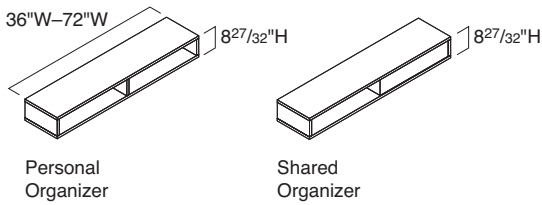

Specifying
▶ Page 302

Organizers

	36"W	42"W	48"W	54"W	60"W	66"W	72"W
15"D Personal	●	●	●	●	●	●	●
15"D Shared	●	●	●	●	●	●	●

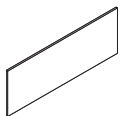

Specifying
▶ Page 304

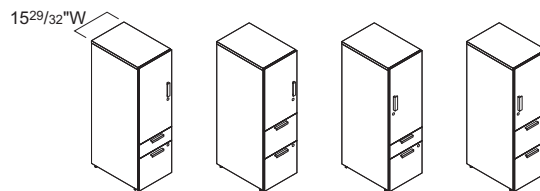

Towers with
doors hinged left,
with drawers

Towers with
doors hinged right,
with drawers

Specifying
▶ Page 306

Tackboards

	24"W-72"W
22-1/4"H-26 1/4"H	●

Single-Door Towers

	18 7/8"D	24"D
41 3/4"H	●	●
47 15/16"H	●	●
54 1/8"H	●	●
66 1/2"H	●	●

Currency, continued

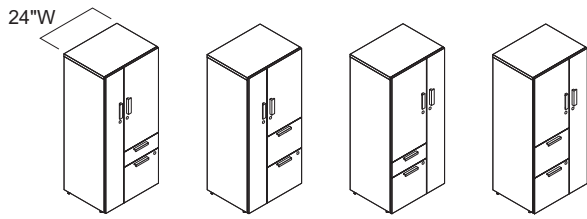

Dual door towers with doors hinged left, with drawers

Dual door towers with doors hinged right, with drawers

Specifying
▶ Page 310

Dual-Door Towers

	18 ⁷ / ₈ "D	24"D
41 ³ / ₄ "H	●	●
47 ¹⁵ / ₁₆ "H	●	●
54 ¹ / ₈ "H	●	●
66 ¹ / ₂ "H	●	●

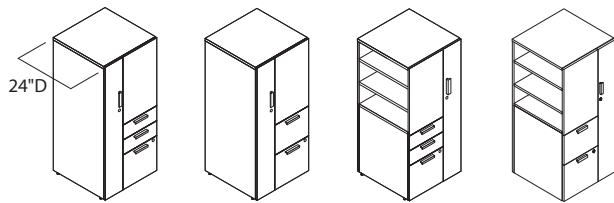

Side access towers with doors hinged left, with drawers

Side access towers with doors hinged right, with drawers

Specifying
▶ Page 314

Side Access Towers

	24"W
41 ³ / ₄ "H	●
47 ¹⁵ / ₁₆ "H	●
54 ¹ / ₈ "H	●
66 ¹ / ₂ "H	●

Currency, continued

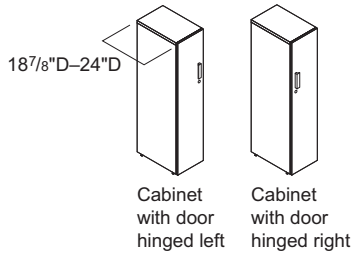

Specifying
▶ Page 318

Cabinets

	12"W	24"W
41 ³ / ₄ "H	●	●
47 ¹⁵ / ₁₆ "H	●	●
54 ¹ / ₈ "H	●	●

Height-Adjustable Desks

Migration SE Height-Adjustable Desks

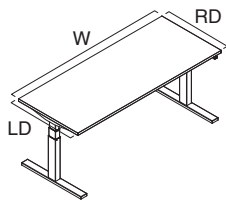

Specifying
▶ Page 320

Rectangular Desks, T-Leg

	46"	52"	58"	64"	70"	76"
23" or 24"D	<input type="checkbox"/>	<input type="checkbox"/>	<input type="checkbox"/>	<input type="checkbox"/>	<input type="checkbox"/>	<input type="checkbox"/>
	46"	52"	58"	64"	70"	76"
29" or 30"D	<input type="checkbox"/>	<input type="checkbox"/>	<input type="checkbox"/>	<input type="checkbox"/>	<input type="checkbox"/>	<input type="checkbox"/>

Tip: Widths are available parametrically in 1/16" increments from 46"–76".

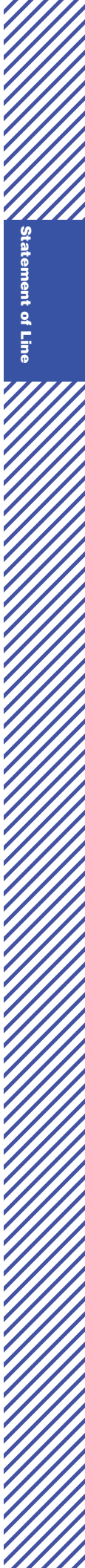

Height-Adjustable Desks, continued

Migration SE Height-Adjustable Desks, continued

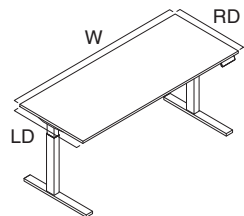

Specifying
▶ Page 321

Rectangular Desks, C-Leg

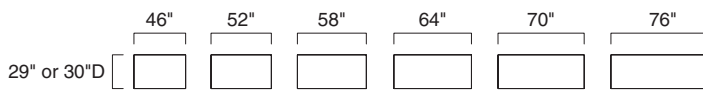

Tip: Widths are available parametrically in 1/16" increments from 46"–76".

Migration SE Cable and Power Management

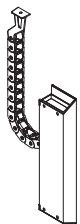

Cable Riser-Leg Connection
Specifying
▶ Page 322

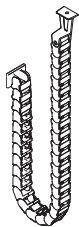

Cable Riser-Fence Connection
Specifying
▶ Page 322

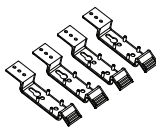

Cable Brackets
Specifying
▶ Page 322

Ology

Ology Height-Adjustable Desks

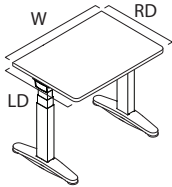

Specifying
▶ Page 324

Rectangular Desks

	34"	40"	46"	52"	58"	64"	70"	76"
23" or 24"D								
	34"	40"	46"	52"	58"	64"	70"	76"
29" or 30"D								

Tip: Widths are available parametrically in 1/16" increments from 34"–78".

Ology Cable and Power Management

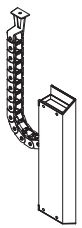

Cable Riser-Leg Connection
Specifying
▶ Page 326

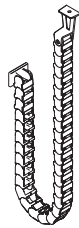

Cable Riser-Fence Connection
Specifying
▶ Page 326

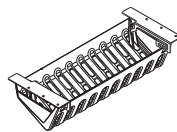

Cable Basket
Specifying
▶ Page 326

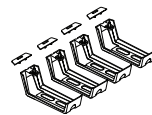

Cable Brackets
Specifying
▶ Page 326

Conference and Collaboration Tables

Groupwork Table Tops

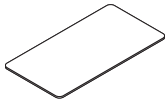

Specifying
▶ Page 327

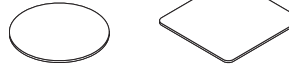

Specifying
▶ Page 328

Rectangular

	36"W	42"W	48"W	60"W	66"W	72"W	84"W
18"D			●	●	●	●	●
24"D	●	●	●	●	●	●	●
30"D	●	●	●	●	●	●	

Round and Square

	24"W	30"W	36"W	42"W	48"W
24"D/Dia.	●				
30"D/Dia.		●			
36"D/Dia.			●		
42"D/Dia.				●	
48"D/Dia.					●

Groupwork Table Bases



Coffee-Height Round Table Bases
Specifying
▶ Page 329

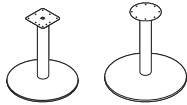

Round Table Bases
Specifying
▶ Page 329

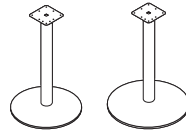

Café-Height Round Table Bases
Specifying
▶ Page 329

Groupwork Table Legs



Post Legs
Specifying
▶ Page 330



Standing-Height Adjustable Post Legs
Specifying
▶ Page 330

Groupwork

Table Components

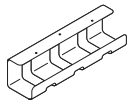

Wire Management Trough
Specifying
▶ Page 332

Screen and Marker Trays

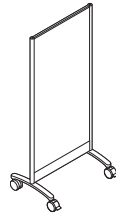

Screens
Specifying
▶ Page 334

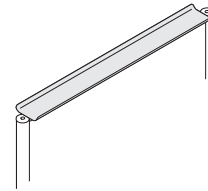

Marker Trays
Specifying
▶ Page 336

Simple Tables

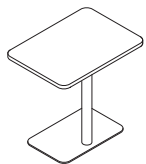

Personal
Specifying
▶ Page 337

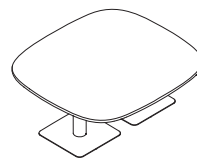
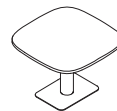
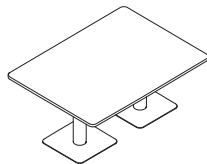
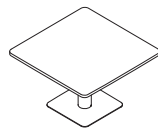
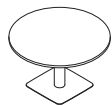

Lounge Height
Specifying
▶ Pages 338–344

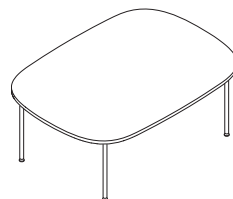
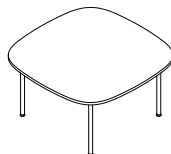
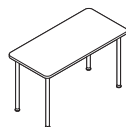
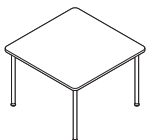

Working Height
Specifying
▶ Pages 346–354



Café Height
Specifying
▶ Pages 356–357



Statement of Line

Simple Tables, continued

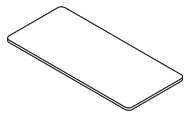

Specifying
▶ Page 359

Straight Tables

$29\frac{3}{4}"$ 711 sq. in.	$35\frac{3}{4}"$ 855 sq. in.	$41\frac{3}{4}"$ 999 sq. in.	$47\frac{3}{4}"$ 1143 sq. in.	$53\frac{3}{4}"$ 1287 sq. in.	$59\frac{3}{4}"$ 1431 sq. in.	$65\frac{3}{4}"$ 1575 sq. in.	$71\frac{3}{4}"$ 1719 sq. in.	$77\frac{3}{4}"$ 1863 sq. in.	} 24"
	$35\frac{3}{4}"$ 1069 sq. in.	$41\frac{3}{4}"$ 1249 sq. in.	$47\frac{3}{4}"$ 1429 sq. in.	$53\frac{3}{4}"$ 1610 sq. in.	$59\frac{3}{4}"$ 1789 sq. in.	$65\frac{3}{4}"$ 1969 sq. in.	$71\frac{3}{4}"$ 2149 sq. in.	$77\frac{3}{4}"$ 2329 sq. in.	



Specifying
▶ Page 360

Round Tables

$30"$ 707 sq. in.	$36"$ 1017 sq. in.	$42"$ 1385 sq. in.	$48"$ 1809 sq. in.	$54"$ 2290 sq. in.
--------------------------	---------------------------	---------------------------	---------------------------	---------------------------



Specifying
▶ Page 361

Square Tables

$24"$ 573 sq. in.	$30"$ 897 sq. in.	$36"$ 1293 sq. in.	$42"$ 1761 sq. in.	$48"$ 2301 sq. in.	$54"$ 2913 sq. in.
--------------------------	--------------------------	---------------------------	---------------------------	---------------------------	---------------------------

Simple Tables, continued

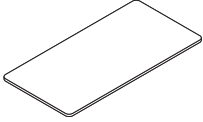

Specifying
▶ Page 362

Rectangle Tables

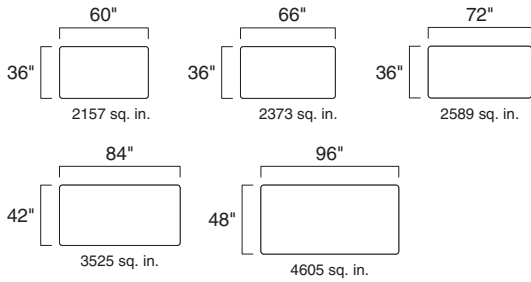

Bases for Universal Tables

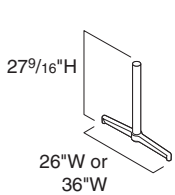

T-Base
Specifying
▶ Page 363

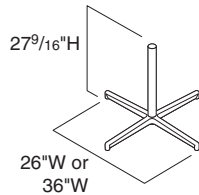

X-Base
Specifying
▶ Page 363

Legs for Universal Tables

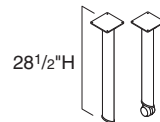

Post Legs with Casters or Glides
Specifying
▶ Page 364

Verb



Specifying
▶ Page 366

Chevron Tables

	60"W
19"D	●
24"D	●



Specifying
▶ Page 368

Team Table

	60"W
24"D	●



Specifying
▶ Page 370

Rectangle Tables

	60"W	72"W
19"D	●	
24"D	●	●
30"D	●	●

Potrero415



Metal Leg

Specifying
▶ Page 372

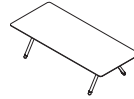

Metal Leg

Specifying
▶ Page 373

Potrero415 Round Table, Metal Legs

Potrero415 Rectangular Tables, Metal Legs

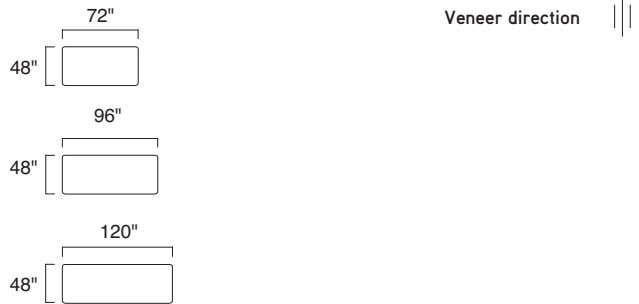

Metal Leg

Specifying
▶ Page 374

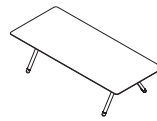

Metal Leg

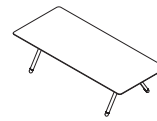

Wood Leg

Specifying
▶ Pages 376 and 378

Potrero415 Light Round Table, Metal Legs

Potrero415 Light Rectangular Tables, Metal and Wood Legs

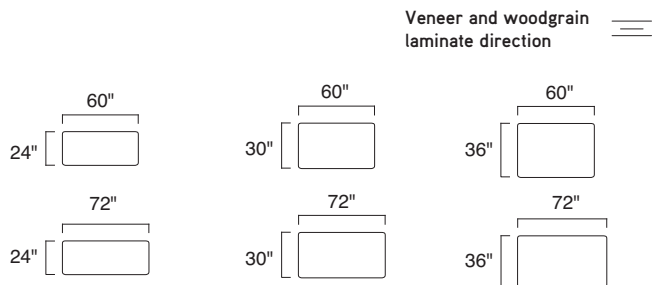

Café Tables

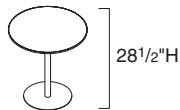

Specifying
▶ Page 380

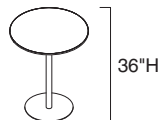

Specifying
▶ Page 381

Montara650 Work-Height Café Tables

Montara650 Café-Height Café Tables

Occasional Tables

Campfire



Campfire Personal Table
Specifying
▶ Page 383



Campfire Skate Table
Specifying
▶ Page 384



Accessories
Specifying
▶ Page 440

Await

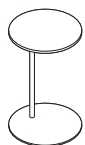

Await Freestanding High Round
Specifying
▶ Page 385

Free Stand

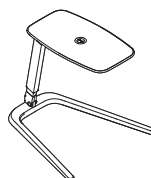

Free Stand Occasional Table
Specifying
▶ Page 386

Lagunitas

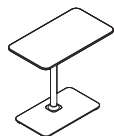

Lagunitas Personal Table
Specifying
▶ Page 387

Screens

Steelcase Flex Collection

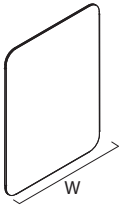

Specifying
▶ Page 388

Rectangle Freestanding Screen

	47"H	71"H
24"W	●	●
30"W	●	●
36"W	●	●

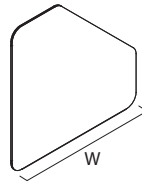

Specifying
▶ Page 388

Angled Freestanding Screen

	47"H
47"W	●

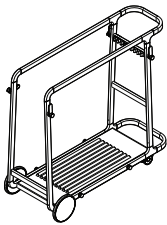

Specifying
▶ Page 389

Board Cart

	41 ³ / ₈ "H
46"W	●

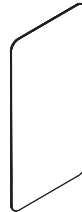

Specifying
▶ Page 390

Markerboard

	47"H	71"H
35 ¹ / ₂ "W	●	●

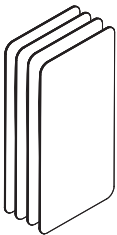

Specifying
▶ Page 390

Markerboard Package

	47"H	71"H
35 ¹ / ₂ "W	●	●



Specifying
▶ Page 390

Stand

	38"H
16" Dia.	●

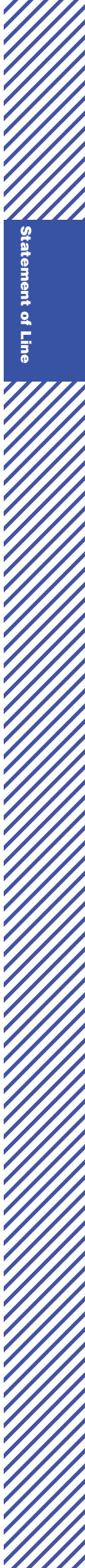

Statement of Line

Screens, continued

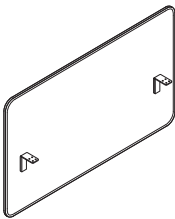

Specifying
▶ Page 392

Sarto Privacy/Modesty Screens

	24"W	29"W	42"W	46"W	48"W	54"W	58"W	60"W	66"W	70"W
24"H	●	●	●	●	●	●	●	●	●	●
30"H	●	●	●	●	●	●	●	●	●	●

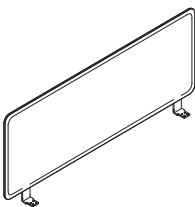

Specifying
▶ Page 394

Sarto Privacy Screens

	24"W	29"W	30"W	36"W	42"W	46"W	48"W	54"W	58"W	60"W	66"W	70"W	72"W	78"W	84"W	90"W	96"W
13 1/2"H	●	●	●	●	●	●	●	●	●	●	●	●	●	●	●	●	●
19 1/2"H	●	●	●	●	●	●	●	●	●	●	●	●	●	●	●	●	●
24"H	●	●	●	●	●	●	●	●	●	●	●	●	●	●	●	●	●
36"H	●	●	●	●	●	●	●	●	●	●	●	●	●	●	●	●	●

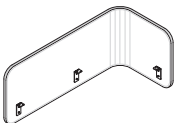

Specifying
▶ Page 396

Sarto Curved Screens, L-Screen

	23"-46"W
18 1/2"-24"H	●

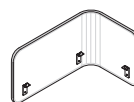

Specifying
▶ Page 397

Sarto Curved Screens, Half Desk-Screen

	23"W	29"W	35"W
18 1/2"-24"H	●	●	●

Storage

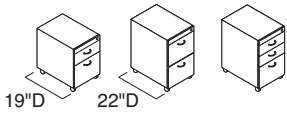

Specifying
▶ Page 398

TS Series Mobile Pedestals with Steel Top

15 1/4"W
21"H ●
26 5/8"H* ●

*Available 22"D only.

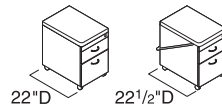

Specifying
▶ Page 399

TS Series Mobile Pedestals with Seat Cushion

15 1/4"W	16 1/4"W
22 3/4"H ●	22 3/4"H* ●

*With handle

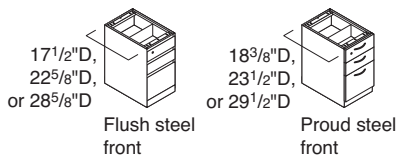

Specifying
▶ Page 401

Universal Fixed Pedestals

15"W
27"H ●

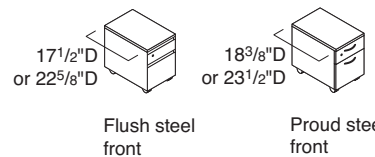

Specifying
▶ Page 406

Universal Mobile Pedestals

15"W
21"H ●
27"H ●

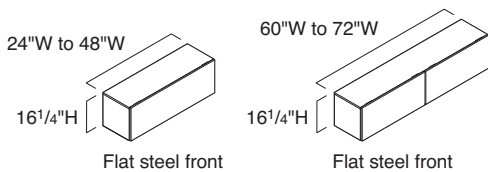

Specifying
▶ Pages 408 and 409

Universal Over the Case and In The Case Bins with Flat Steel Fronts

For Use with Answer and Kick

24"W	30"W	36"W	42"W	48"W	60"W	66"W	72"W
15 3/4"D ●	●	●	●	●	●	●	●



Statement of Line

Storage, continued

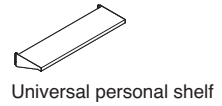
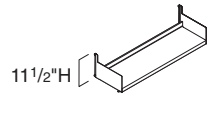
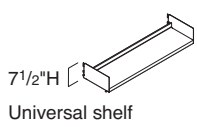

Specifying
▶ Pages 410–411

Universal Shelves and Universal Personal Shelves

	24"W	30"W	36"W	42"W	48"W	60"W	72"W
Universal Shelves							
For use with Answer and Kick							
14 3/4"D	•	•	•	•	•	•	•
Universal Personal Shelves							
For use with Answer and Kick							
13 1/16"D	•	•	•	•	•		

Storage, continued

Universal One-High

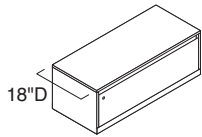

Flush steel front

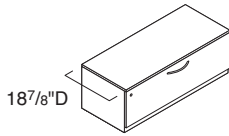

Proud steel front

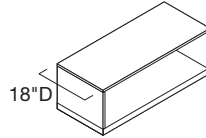

Flush steel open front

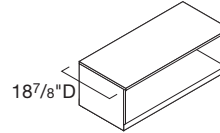

Proud steel open front

Universal 1.5-High

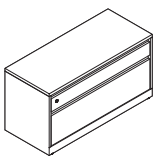

Flush steel front

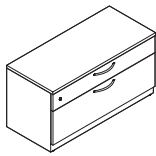

Proud steel front

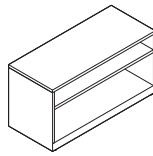

Flush steel open front

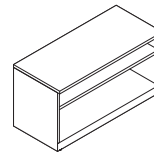

Proud steel open front

Two Drawer

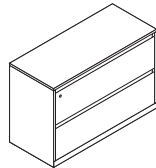

Flush steel front

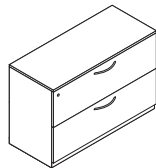

Proud steel front

Specifying
▶ Page 416

Universal One-High, 1.5-High, and Two Drawer Lateral Files

		30"W	36"W	42"W
One-High	16"H	●	●	●
1.5-High	22"H	●	●	●
Two Drawer	28"H	●	●	●

Tip: 42"W lateral files are available 18"D and 18 7/8"D only.

Storage, continued

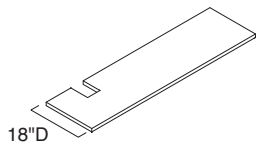

Specifying
▶ Page 435

Universal Common Tops

For Ology Applications

60"W	66"W	72"W	78"W	84"W	90"W	96"W	108"W
●	●	●	●	●	●	●	●

Drawings show right application.
Units are also available with left application.

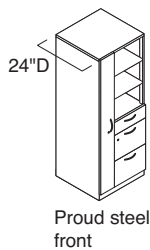
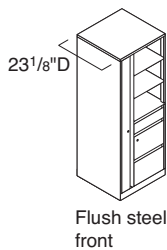

Specifying
▶ Page 420

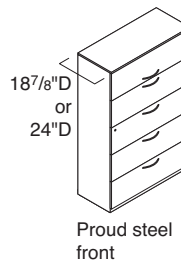
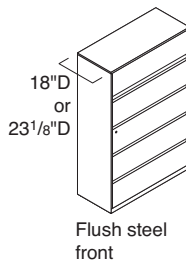

Specifying
▶ Page 422

Universal Open Side Towers

	24"W
52"H	●
65 1/2"H	●

Drawings show door hinged left.
Units are also available with door hinged right.

Universal Lateral Files

	30"W	36"W	42"W
40"H	●	●	●
52"H	●	●	●
65 1/2"H	●	●	●

Tip: 42"W lateral files are available 18"D and 18 7/8"D only.

Storage, continued

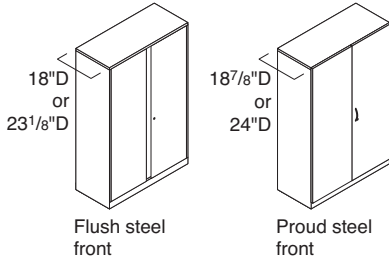

Flush steel front

Proud steel front

Specifying
▶ Page 424

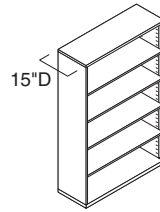

Specifying
▶ Page 428

Universal Storage Cabinets

	30"W	36"W	42"W
28"H	●	●	●
40"H	●	●	●
52"H	●	●	●
65½"H	●	●	●
83½"H	●	●	●

Tip: 42"W storage cabinets are available 18"D and 18⅞"D only.

Universal Bookcases

	24"W	30"W	36"W	42"W
28"H	●	●	●	●
40"H	●	●	●	●
53½"H	●	●	●	●
65½"H	●	●	●	●
83½"H	●	●	●	●

Whiteboards

Wall Mounted

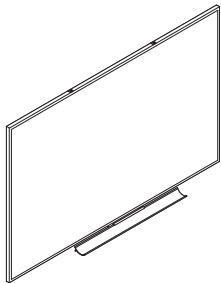

Parametric Premium Whiteboards and Tackboards
Specifying
▶ Page 442

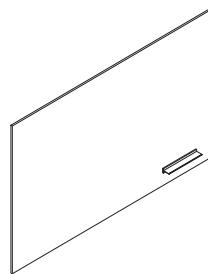

Sans
Specifying
▶ Page 447

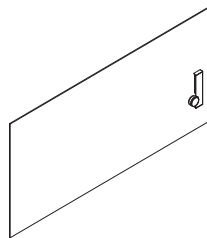

Sans Light
Specifying
▶ Page 448



Statement of Line

Verb



Verb Personal Whiteboard
Specifying
▶ Page 449



Verb Easel
Specifying
▶ Page 450



Verb Wall Track
Specifying
▶ Page 451

Worktools

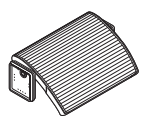

Adjustable Foot Rest
Specifying
▶ Page 452

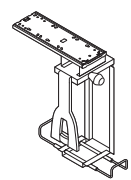

Vertical Locking CPU Cradle
Specifying
▶ Page 452

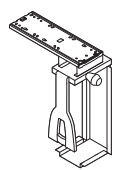

Vertical Non-Locking CPU Cradle
Specifying
▶ Page 452



Specifying
▶ Page 454

Tracks

20"L	23"L
●	●

Statement of Line and Comparison

Task lights offer end users added control and adjustability to place the proper amount of task lighting to create a holistic work setting.

LED Lights

dash and dash mini LED Lights

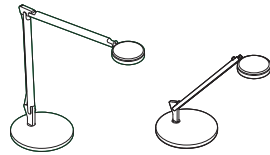

LED Radial and Linear Desktop Lights

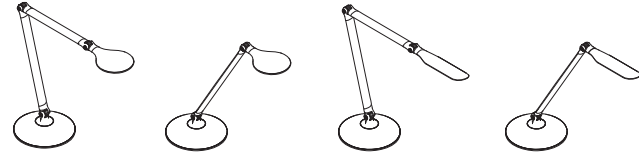

Mounting Options	<ul style="list-style-type: none"> • Freestanding • Freestanding with USB • C-clamp for worksurfaces 3/4" to 1 1/2" thick • Slatwall • Panel • Rails—SOTO, Ology, Elective Elements, FrameOne, Campfire, Answer beam, and Tour 	<ul style="list-style-type: none"> • Freestanding • Freestanding with USB • C-clamp for worksurfaces 7/8" to 1 7/8" thick • Slatwall • Panel • Rails—SOTO, Ology, Elective Elements, FrameOne, Campfire, Answer beam, and Tour • Through mount • Theft deterrent through-mount
	Specifying ▶ Pages 455–458	Specifying ▶ Pages 459–460
Watts/Lumens/Efficacy	9.3 Watts/570 Lumens/61.3 Efficacy	7.5 Watts/337 Lumens/44.9 Efficacy
Color Rendering Index	94	85
Color Temperature	3500K	3500K
Automatic Turn Off	10 hours	10 hours
Horizontal Arm Range	Standard 0"–37" Mini 0"–24"	Radial Double 8"–20 1/2" Single 0"–13" Linear Double 10"–22 1/2" Single 2"–15"
Vertical Height Adjustment	Standard 2"–25" Mini 0"–20 3/8"	Radial Double 6"–21 1/2" Single 13"–16 1/2" Linear Double 6"–21 1/2" Single 13"–16 1/2"
Tilt/Swivel	360° at light head, 160° at freestanding base, and 360° at mounting bracket	90° vertical tilt at head and 320° at base
Replacement Lamp/Bulb	• Not available	• Not available
Average Rated Lamp Life	• 50,000 hrs.	• 50,000 hrs.
Finish Options	• Paint: Arctic White (4231), Low Gloss Black (4710), Platinum Metallic (4799)	• Paint: Arctic White (4231), Low Gloss Black (4710), or Platinum Metallic (4799)
Electronic Dimmer	• 100%–15%	• 100%–15%
Occupancy Sensor	• Available	• Available
USB Ports	<ul style="list-style-type: none"> • One type-A (2.4A max) • One type-C (60-watt max) 	• One type-A (1.2A max)

* For complete listing of accent paints, see *Surface Materials* on page 480.

Task lights offer end users added control and adjustability to place the proper amount of task lighting to create a holistic work setting.

LED Lights

LED Intro Task Light Single Arm

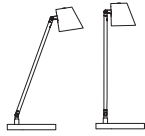

LED Intro Task Light Double Arm

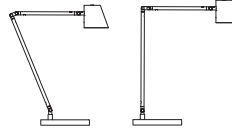

Mounting Options	• Freestanding Base	
	Specifying ▶ Page 461	Specifying ▶ Page 461
Watts/Lumens/Efficacy	7 Watts/400 Lumens/62 Efficacy	7 Watts/400 Lumens/62 Efficacy
Color Rendering Index	90	90
Color Temperature	3000K	3000K
Horizontal Arm Range	0"–9 ² / ₅ "	3"–19 ¹ / ₄ "
Vertical Height Adjustment	17 ² / ₅ "–18 ⁹ / ₂₀ "	9 ¹ / ₅ "–24 ⁴ / ₅ "
Tilt/Swivel	• Light head pivot – 180° up/down • Swivel – 350°	• Light head pivot – 180° up/down • Swivel – 350°
Replacement Lamp/Bulb	• Not available	• Not available
Average Rated Lamp Life	• 50,000 hrs.	• 50,000 hrs.
Finish Options	• Paint: Black Matte (4135) or Platinum Gloss (4142)	• Paint: Black Matte (4135) or Platinum Gloss (4142)
Electronic Dimmer	• Three-step: 10%–50%–100%	• Three-step: 10%–50%–100%
Occupancy Sensor	• Not available	• Not available
Warranty	• 3 year warranty	• 3 year warranty
Power Supply Wattage	• 12 watts	• 12 watts
Power Supply Voltage	• 24 volts	• 24 volts
Cord length	• 75" (6 ¹ / ₄)	• 75" (6 ¹ / ₄)
Cord material	• Black plastic only	• Black plastic only
Wireless Charging Wattage	• Not available	• Not available

Statement of Line and Comparison, continued

Shelf lights offer end users added control and adjustability to place the proper amount of shelf lighting to create a holistic work setting. Ideally suited for recessed mount applications to bottom of bin or shelf.

Shelf Lights

Storage-Mounted Lights

LED Shelf Light

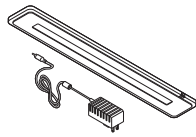

LED Linear Shelf Lights

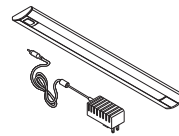

Mounting

- Standard includes magnetic mount for steel bins and shelves. Optional fastener kit for wood shelves are available.

- Standard includes magnetic mount for steel bins and shelves. Each light length comes with set quantity of mounting brackets for both steel and wood applications.

Specifying
▶ Page 462

Specifying
▶ Page 466

Depth

2 1/2"

2"

Width

18"

17", 31", 44", or 58"

Number of LEDs

- 102 LEDs

17"W	31"W	44"W	58"W	
24	48	72	96	Standard Output LEDs
47	94	141	188	High Output LEDs

Watts/Lumens/Efficacy

9.6 Watts/522 Lumens/54 Efficacy

17"W	31"W	44"W	58"W	
6.7	13.1	19.1	25.3	Standard Output Watts LEDs
9.1	17.6	25.9	33.7	System Wattage Lumens
474	970	1447	1942	Efficacy (Lumens/Watts LEDs)
70.0	74.1	75.8	76.8	
17"W	31"W	44"W	58"W	
9.5	17.1	24.6	32.3	High Output Watts LEDs
10.2	19.7	28.2	38.2	System Wattage Lumens
751	1497	2131	2827	Efficacy (Lumens/Watts LEDs)
74.0	76.0	75.5	74.0	

Color Rendering Index

94

92

Color Temperature

3500K

3500K

Description

An environmentally-friendly light that consumes only 11 watts of power, contains no harmful metals (mercury), and has a useful life of over 50,000 hours. Ideally suited for recessed mount applications to bottom of bin or shelf.

With its low profile and available four widths, the LED linear light will fit in a variety of shelving and overhead storage applications. Beneficial features of this fixture include: energy efficient LEDs, continuous dimming, automatic turn off after 10 hours, and optional occupancy sensor.

Finish Options

- Bottom surface clear anodized aluminum only. Plastic cover Arctic White (6009) or Black (6000).
- 4231 Arctic White body with Arctic White (6009) end caps or 0835 Black body with Black (6000) end caps.

Optics

- Polycarbonate matte film
- Polycarbonate matte film

Ballasts

- Energy saving low-voltage power supply
- Energy saving low-voltage power supply

Electronic Dimmer

- Standard on all lights
- Standard on all lights

Average Rated Lamp Life

- 50,000 hrs.
- 50,000 hrs.

Warranty

- Power supply - 5 years
- Fixture - 12 years
- Power supply - 5 years
- Fixture - 12 years

Shelf lights mount into the recessed bottom of storage shelves and bins to illuminate the worksurface. Five types of shelf lights are available to control the quality of light for specific applications. Each type is compatible with Steelcase systems furniture.

Shelf Lights

Storage-Mounted Lights

Standard Shelf Light

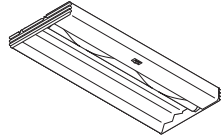

Mounting Options	<ul style="list-style-type: none"> • Universal mounting package (standard) • Flush mount • Competitive mounting package <p>Specifying ▶ Page 464</p>
Depth	9¼"
Width	25", 37", or 49"
Lamp	• T8 Fluorescent
Watts/Lumens/Efficacy	25"W – 17 Watts/1343 Lumens/79 Efficacy 37"W – 25 Watts/2150 Lumens/86 Efficacy 49"W – 32 Watts/2899 Lumens/90.6 Efficacy
Color Temperature	3500K
Description	The right choice for the majority of people in today's workplace who switch frequently from task to task throughout the day.
Optics	<ul style="list-style-type: none"> • Faceted, white reflector • Contrast sleeve that can be manually rotated to vary light
Ballasts	<ul style="list-style-type: none"> • Electronic ballast • High power factor ballast
Electronic Dimmer	• Not available
Lens Options	• None
Average Rated Lamp Life	• 20,000 hours
Warranty	<ul style="list-style-type: none"> • Ballast—5 years • Fixture—12 years

Statement of Line and Comparison, continued

Shelf lights offer end users added control and adjustability to place the proper amount of shelf lighting to create a holistic work setting. Ideally suited for recessed mount applications to bottom of bin or shelf.

Shelf Lights

Bottomline Light

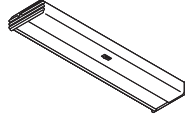

Mounting	<ul style="list-style-type: none"> Standard includes universal spring bracket for recessed mount or screw-in for flush mount (tool free clips for New York applications). <p>Specifying ▶ Page 468</p>
Depth	4 1/2"
Width	23 1/4", 35", or 46 3/4"
Height	1 1/4"
Weight	4.02 lb, 4.95 lb, or 6.9 lb
Lamp	<ul style="list-style-type: none"> T5 Fluorescent
Watts/Lumens/Efficacy	23 1/4"W – 14 Watts/1275 Lumens/91 Efficacy 35"W – 21 Watts/2000 Lumens/95 Efficacy 46 3/4"W – 28 Watts/2697 Lumens/96 Efficacy
Color Temperature	3500K
Description	Designed to be environmentally friendly providing 15% more light with an even distribution of light on the worksurface. Ideally suited for recessed mount applications to bottom of bin or shelf.
Finish Options	<ul style="list-style-type: none"> Paint: Black (0835) or Pewter (7018)
Optics	<ul style="list-style-type: none"> Mylar reflector with batwing lens
Ballasts	<ul style="list-style-type: none"> Energy saving electronic ballast
Electronic Dimmer	<ul style="list-style-type: none"> Not available
Average Rated Lamp Life	<ul style="list-style-type: none"> 20,000 hrs.
Warranty	<ul style="list-style-type: none"> Ballast - 5 years Fixture - 12 years

Power and Cable Management

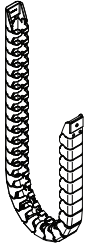

High-Capacity Cable Riser
Specifying
▶ Page 469



Vertical Cable Carrier
Specifying
▶ Page 469

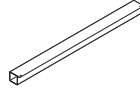

1 3/4\"D Wire Managers
Specifying
▶ Page 470

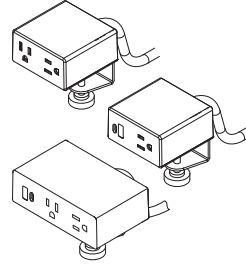

Powerstrip Intro
Specifying
▶ Page 471



Powerstrip Plus
Specifying
▶ Page 472

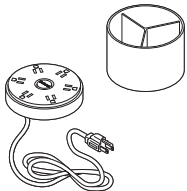

PowerPod
Specifying
▶ Page 474

CF Flat Panel Monitor Arms and Supports

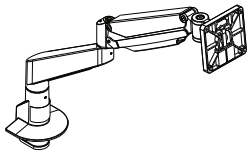

CF Intro Single Monitor Arm
Specifying
▶ Page 475

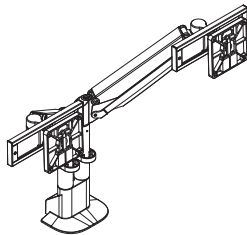

CF Intro Monitor Arm
Specifying
▶ Page 475

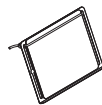

CF Laptop Holder Platform
Specifying
▶ Page 476



CF Arm Bracket Connector
Specifying
▶ Page 476



CF C-Clamp
Specifying
▶ Page 477



CF Wall/Reverse Wall-Mount Bracket
Specifying
▶ Page 477



CF Slatwall Bracket
Specifying
▶ Page 477

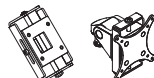

CF Monitor Arm Adapters and Tilt Heads
Specifying
▶ Page 478



CF Articulating Arm Extensions for Pole Mount Assemblies
Specifying
▶ Page 479

Gesture 442 Series Work Chairs



	Standard Includes	Required to Specify
▶ See <i>Seating Specification Guide</i> for product details.	<ul style="list-style-type: none"> • 5" pneumatic seat-height adjustment (16"-21") • 360° independent height-, width-, pivot-, and depth-adjustable arms and soft arm caps: black plastic • Frame, seat shell, outer back, and five-arm base: plastic • 2¾" seat depth adjustment • Standard upholstery design on seat: fabric price group 1 • Shell back chair, if selected: fabric price group 1 • Wrapped back chair, if selected: fabric price group 1 • 3D Knit on back only, if selected • 2½" diameter, hard-composition, dual-wheel casters: black 	<ol style="list-style-type: none"> 1 Style number 2 Plastic color scheme for frame, seat shell, outer back, and base (see below under Required Selections) 3 Fabric color number for upholstery on seat and back, if selected 4 3D Knit color number for upholstery on back, if selected 5 Options, if selected (see below) <p>▶ See <i>Surface Materials</i>, page 480.</p>

	Required Selections	Required to Specify
Color Scheme	<ul style="list-style-type: none"> • Black/Black • Dark/Dark • Dark/Light • Light/Light 	<p>Specify with <i>black/black color scheme</i>.</p> <p>Specify with <i>dark/dark color scheme</i>.</p> <p>Specify with <i>dark/light color scheme</i>.</p> <p>Specify with <i>light/light color scheme</i>.</p>

	Options	Required to Specify
Surface Materials	Upholstery on seat <ul style="list-style-type: none"> • Fabric price group 1 • Fabric price group 2 • Fabric price group 3 • Fabric price group 5 • Fabric price group 6 	<p>Specify fabric color number.</p> <p>Specify fabric color number.</p> <p>Specify fabric color number.</p> <p>Specify fabric color number.</p>
	Upholstery on back <ul style="list-style-type: none"> • Fabric price group 1 • Fabric price group 2 • Fabric price group 3 • Fabric price group 5 • Fabric price group 6 • 3D Knit 	<p>Specify fabric color number.</p> <p>Specify fabric color number.</p> <p>Specify fabric color number.</p> <p>Specify fabric color number.</p> <p>Specify fabric color number.</p> <p>Specify 3D Knit fabric color number.</p>
	Polished aluminum base package <ul style="list-style-type: none"> • Polished aluminum base on chairs 	<p>Specify with <i>polished aluminum base</i>.</p>
Arms	<ul style="list-style-type: none"> • Armless 	<p>Specify <i>without arms</i>.</p>
Seat Height	<ul style="list-style-type: none"> • 3¾" low-range pneumatic seat-height adjustment (14½" to 18¼") 	<p>Specify with <i>low-range pneumatic seat-height adjustment</i>.</p>
	<ul style="list-style-type: none"> • 5½" high-range pneumatic seat-height adjustment (17" to 22½") 	<p>Specify with <i>high-range pneumatic seat-height adjustment</i>.</p>
Lumbar	<ul style="list-style-type: none"> • Adjustable lumbar support 	<p>Specify with <i>adjustable lumbar height</i>.</p>
Casters	<ul style="list-style-type: none"> • Soft, dark grey treaded, dual-wheel roll-control casters for use on hard floors 	<p>Specify with <i>soft roll-control casters</i>.</p>
Glides	<ul style="list-style-type: none"> • Glides: plastic 	<p>Specify with <i>glides</i>.</p>
CarbonNeutral Product	<ul style="list-style-type: none"> • CarbonNeutral product certification 	<p>Add CN suffix.</p>

Tip: Seat and back will be a matching textile unless 3D Knit is specified.

Tip: When glides are specified, chairs will ship with casters installed and glides provided to install after delivery.

Specification Information

• **Style
Number**

Wrapped Back Chair

442A40



Shell Back Chair

442A30



Gesture 442 Series Work Chair with Headrest

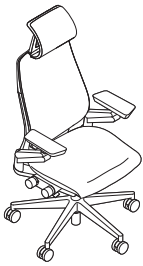

	Standard Includes	Required to Specify
▶ See <i>Seating Specification Guide</i> for product details.	<ul style="list-style-type: none"> 5" pneumatic seat-height adjustment (16"-21") 360° independent height-, width-, pivot-, and depth-adjustable arms and soft arm caps: black plastic Frame, seat shell, outer back, and five-arm base: plastic 2¾" seat depth adjustment Standard upholstery design on seat: fabric price group 1 Adjustable headrest, standard upholstery 3D Knit on back and headrest only, if selected 2½" diameter, hard-composition, dual-wheel casters: black 	<ol style="list-style-type: none"> Style number Plastic color scheme for frame, seat shell, outer back, headrest, and base (see below under Required Selections) Fabric color number for upholstery on seat and back, if selected Fabric color number for upholstery on headrest 3D Knit color number for upholstery on back, if selected Options, if selected (see below) <p>▶ See <i>Surface Materials</i>, page 480.</p>

	Required Selections	Required to Specify
Color Scheme	<ul style="list-style-type: none"> Black/Black Dark/Dark Dark/Light Light/Light 	<p>Specify with <i>black/black color scheme</i>. Specify with <i>dark/dark color scheme</i>. Specify with <i>dark/light color scheme</i>. Specify with <i>light/light color scheme</i>.</p>

	Options	Required to Specify
Surface Materials	<p>Upholstery on seat</p> <ul style="list-style-type: none"> Fabric price group 1 Fabric price group 2 Fabric price group 3 Fabric price group 5 Fabric price group 6 <p>Upholstery on back</p> <ul style="list-style-type: none"> Fabric price group 1 Fabric price group 2 Fabric price group 3 Fabric price group 5 Fabric price group 6 3D Knit <p>Polished aluminum base package</p> <ul style="list-style-type: none"> Polished aluminum base on chairs 	<p>Specify fabric color number. Specify fabric color number. Specify fabric color number. Specify fabric color number. Specify fabric color number.</p> <p>Specify fabric color number. Specify fabric color number. Specify fabric color number. Specify fabric color number. Specify 3D Knit fabric color number.</p> <p>Specify with <i>polished aluminum base</i>.</p>
Arms	<ul style="list-style-type: none"> Armless 	Specify <i>without arms</i> .
Seat Height	<ul style="list-style-type: none"> 3¾" low-range pneumatic seat-height adjustment (14½" to 18¼") 5½" high-range pneumatic seat-height adjustment (17" to 22½") 	<p>Specify with <i>low-range pneumatic seat-height adjustment</i>.</p> <p>Specify with <i>high-range pneumatic seat-height adjustment</i>.</p>
Lumbar	<ul style="list-style-type: none"> Adjustable lumbar support 	Specify with <i>adjustable lumbar height</i> .
Casters	<ul style="list-style-type: none"> Soft, dark grey treaded, dual-wheel roll-control casters for use on hard floors 	Specify with <i>soft roll-control casters</i> .
Glides	<ul style="list-style-type: none"> Glides: plastic 	Specify with <i>glides</i> .
CarbonNeutral Product	<ul style="list-style-type: none"> CarbonNeutral product certification 	Add CN suffix.

Tip: Seat and back will be a matching textile unless 3D Knit is specified.

Tip: When glides are specified, chairs will ship with casters installed and glides provided to install after delivery.

Specification Information	
Style Number	
442A50	

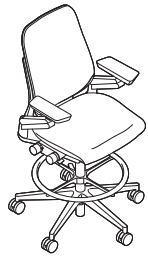

Standard Includes		Required to Specify
<ul style="list-style-type: none"> ▶ See <i>Seating Specification Guide</i> for product details. 	<ul style="list-style-type: none"> • 8¼" pneumatic seat-height adjustment (24"-32¼") • 360° independent height-, width-, pivot-, and depth-adjustable arms and soft arm caps: black plastic • Frame, seat shell, outer back, and five-arm base: plastic • 2¾" seat depth adjustment • Column and 4" adjustable foot ring • Standard upholstery design on seat: fabric price group 1 • Shell back stool, if selected: fabric price group 1 • Wrapped back stool, if selected: fabric price group 1 • 3D Knit on back only, if selected • 2½" diameter, hard-composition, dual-wheel casters: black 	<ol style="list-style-type: none"> 1 Style number 2 Plastic color scheme for frame, seat shell, outer back, and base (see below under Required Selections) 3 Fabric color number for upholstery on seat and back, if selected 4 3D Knit color number for upholstery on back, if selected 5 Options, if selected (see below) <ul style="list-style-type: none"> ▶ See <i>Surface Materials</i>, page 480.

Required Selections		Required to Specify
Color Scheme	<ul style="list-style-type: none"> • Black/Black • Dark/Dark • Dark/Light • Light/Light 	<p>Specify with <i>black/black color scheme</i>. Specify with <i>dark/dark color scheme</i>. Specify with <i>dark/light color scheme</i>. Specify with <i>light/light color scheme</i>.</p>

Options		Required to Specify
Surface Materials	<p>Upholstery on seat</p> <ul style="list-style-type: none"> • Fabric price group 1 • Fabric price group 2 • Fabric price group 3 • Fabric price group 5 • Fabric price group 6 <p>Upholstery on back</p> <ul style="list-style-type: none"> • Fabric price group 1 • Fabric price group 2 • Fabric price group 3 • Fabric price group 5 • Fabric price group 6 • 3D Knit <p>Polished aluminum base package</p> <ul style="list-style-type: none"> • Polished aluminum base on chairs 	<p>Specify fabric color number. Specify fabric color number. Specify fabric color number. Specify fabric color number. Specify fabric color number.</p> <p>Specify fabric color number. Specify fabric color number. Specify fabric color number. Specify fabric color number. Specify 3D Knit fabric color number.</p> <p>Specify with <i>polished aluminum base</i>.</p>
Arms	<ul style="list-style-type: none"> • Armless 	Specify <i>without arms</i> .
Lumbar	<ul style="list-style-type: none"> • Adjustable lumbar support 	Specify with <i>adjustable lumbar height</i> .
Casters	<ul style="list-style-type: none"> • Soft, dark grey treaded, dual-wheel roll-control casters for use on hard floors 	Specify with <i>soft roll-control casters</i> .
Glides	<ul style="list-style-type: none"> • Glides: plastic 	Specify with <i>glides</i> .
CarbonNeutral Product	<ul style="list-style-type: none"> • CarbonNeutral product certification 	Add CN suffix.

Tip: Seat and back will be a matching textile unless 3D Knit is specified.

Tip: When glides are specified, chairs will ship with casters installed and glides provided to install after delivery.

Specification Information

• **Style Number**

Wrapped Back Stool

442B40

Shell Back Stool

442B30

Leap 462 Series Work Chair

Upholstery on Back and Seat



Standard Includes		Required to Specify
<ul style="list-style-type: none"> ▶ See <i>Seating Specification Guide</i> for product details. 	<ul style="list-style-type: none"> • Upper back force • 5" pneumatic seat-height adjustment • Variable back stop • Lower back firmness • Rectilinear independent height-, width-, pivot-, and depth- adjustable arms and soft arm caps, if selected: black plastic • Frame, seat shell, outer back, and five-arm base: plastic • 3" seat depth adjustment • Passive seat edge angle • Adjustable lumbar • Standard upholstery design: fabric price group 1 • 2½"-diameter, hard-composition, dual-wheel casters: black 	<ol style="list-style-type: none"> 1 Style number 2 Plastic color for frame, seat shell, outer back, and base 3 Fabric color number for upholstery on seat and back 4 Options, if selected (see below) <ul style="list-style-type: none"> ▶ See <i>Surface Materials</i>, page 480.

Options		Required to Specify
Surface Materials	<p>Upholstery on seat and back</p> <ul style="list-style-type: none"> • Fabric price group 1 • Fabric price group 2 • Fabric price group 3 • Fabric price group 5 • Fabric price group 6 • Steelcase vinyl <p>Sewn upholstery</p> <ul style="list-style-type: none"> • Sewn upholstery on chair <p>Platinum/midnight</p> <ul style="list-style-type: none"> • On frame, base, arm retainer, and outer back 	<p>Specify fabric color number.</p> <p>Specify fabric color number.</p> <p>Specify fabric color number.</p> <p>Specify fabric color number.</p> <p>Specify fabric color number.</p> <p>Add S to the style number and specify vinyl color number.</p> <hr/> <p>Add S suffix.</p> <hr/> <p>Specify with <i>6249 Platinum</i> or with <i>6259 Midnight</i>.</p>
Arms	<ul style="list-style-type: none"> • Height-adjustable arms, soft arm caps • Armless 	<p>Specify with <i>height-adjustable arms</i>.</p> <p>Specify <i>without arms</i>.</p>
Seat Height	<ul style="list-style-type: none"> • 7" pneumatic seat-height adjustment 	<p>Specify with <i>7" pneumatic seat-height adjustment</i>.</p>
Lumbar	<ul style="list-style-type: none"> • Without lumbar 	<p>Specify <i>without lumbar</i>.</p>
Casters	<ul style="list-style-type: none"> • Soft, dark grey treaded, dual-wheel roll-control casters for use on hard floors 	<p>Specify with <i>soft roll-control casters</i>.</p>
Glides	<ul style="list-style-type: none"> • Glides: plastic 	<p>Specify with <i>glides</i>.</p>
CarbonNeutral Product	<ul style="list-style-type: none"> • CarbonNeutral product certification 	<p>Add CN suffix.</p>

Tip: When glides are specified, chairs will ship with casters installed and glides provided to install after delivery.

*Tip: Suffix **CN** will be added after **S** if CarbonNeutral is selected.*

Specification Information	
• Style Number	
•	
•	
•	
•	
• 46216179	
•	
•	

Leap 462 Series Work Chair

3D Knit on Back with Upholstery on Seat

Leap 462 Series
Work Chair



Standard Includes		Required to Specify
<ul style="list-style-type: none"> ▶ See <i>Seating Specification Guide</i> for product details. 	<ul style="list-style-type: none"> • Upper back force • 5" pneumatic seat-height adjustment • Variable back stop • Lower back firmness • Rectilinear independent height-, width-, pivot-, and depth- adjustable arms and soft arm caps, if selected: black plastic • Frame, seat shell, outer back, and five-arm base: plastic • 3" seat depth adjustment • Passive seat edge angle • Adjustable lumbar • 3D Knit on back only • Standard upholstery design on seat: fabric price group 1 • 2½"-diameter, hard-composition, dual-wheel casters: black 	<ol style="list-style-type: none"> 1 Style number 2 Plastic color for frame, seat shell, outer back, and base 3 3D Knit color for back 4 Fabric color number for upholstery on seat 5 Options, if selected (see below) <ul style="list-style-type: none"> ▶ See <i>Surface Materials</i>, page 480.

Options		Required to Specify
Surface Materials	<p>Upholstery</p> <ul style="list-style-type: none"> • Fabric price group 1 • Fabric price group 2 • Fabric price group 3 • Fabric price group 5 • Fabric price group 6 • Steelcase vinyl <p>Sewn upholstery</p> <ul style="list-style-type: none"> • Sewn upholstery on chair <p>Platinum/midnight</p> <ul style="list-style-type: none"> • On frame, base, arm retainer, and outer back 	<p>Specify fabric color number. Specify fabric color number. Specify fabric color number. Specify fabric color number. Specify fabric color number. Add S to the style number and specify vinyl color number.</p> <p>Add S suffix.</p> <p>Specify with <i>6249 Platinum</i> or with <i>6259 Midnight</i>.</p>
Arms	<ul style="list-style-type: none"> • Height-adjustable arms, soft arm caps • Armless 	Specify with <i>height-adjustable arms</i> . Specify <i>without arms</i> .
Seat Height	<ul style="list-style-type: none"> • 7" pneumatic seat-height adjustment 	Specify with <i>7" pneumatic seat-height adjustment</i> .
Lumbar	<ul style="list-style-type: none"> • Without lumbar 	Specify <i>without lumbar</i> .
Casters	<ul style="list-style-type: none"> • Soft, dark grey treaded, dual-wheel roll-control casters for use on hard floors 	Specify with <i>soft roll-control casters</i> .
Glides	<ul style="list-style-type: none"> • Glides: plastic 	Specify with <i>glides</i> .
CarbonNeutral Product	<ul style="list-style-type: none"> • CarbonNeutral product certification 	Add CN suffix.

Tip: Suffix **CN** will be added after **S** if CarbonNeutral is selected.

Specification Information	
Style Number	
46216189	

Work Chairs

Leap 462 Series Stool

Upholstery on Back and Seat

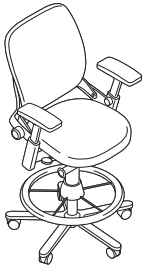

	Standard Includes	Required to Specify
▶ See <i>Seating Specification Guide</i> for product details.	<ul style="list-style-type: none"> • Upper back force • 8" pneumatic seat-height adjustment • Variable back stop • Lower back firmness • Passive seat edge angle • Rectilinear independent height-, width-, pivot-, and depth-adjustable arms and soft arm caps, if selected: black plastic • Frame, seat shell, outer back, and five-arm base: plastic • 3" seat depth adjustment • Column and 4" adjustable foot ring: black • Standard upholstery design: fabric price group 1 • 2"-diameter, hard-composition, dual-wheel casters: black 	<ul style="list-style-type: none"> 1 Style number 2 Plastic color for frame, seat shell, outer back, and base 3 Fabric color number for upholstery on seat and back 4 Options, if selected (see below) <ul style="list-style-type: none"> ▶ See <i>Surface Materials</i>, page 480.

	Options	Required to Specify
Surface Materials	<p>Upholstery on seat and back</p> <ul style="list-style-type: none"> • Fabric price group 1 • Fabric price group 2 • Fabric price group 3 • Fabric price group 5 • Fabric price group 6 • Steelcase vinyl 	<ul style="list-style-type: none"> Specify fabric color number. Specify fabric color number. Specify fabric color number. Specify fabric color number. Specify fabric color number. Add S to the style number and specify vinyl color number.
	<p>Sewn upholstery</p> <ul style="list-style-type: none"> • Sewn upholstery on chair 	<ul style="list-style-type: none"> Add S suffix.
	<p>Platinum/midnight</p> <ul style="list-style-type: none"> • On frame, base, arm retainer, and outer back 	<ul style="list-style-type: none"> Specify <i>with 6249 Platinum or with 6259 Midnight.</i>
Arms	<ul style="list-style-type: none"> • Height-adjustable arms, soft arm caps • Armless 	<ul style="list-style-type: none"> Specify <i>with height-adjustable arms.</i> Specify <i>without arms.</i>
Lumbar	<ul style="list-style-type: none"> • Without lumbar 	<ul style="list-style-type: none"> Specify <i>without lumbar.</i>
Casters	<ul style="list-style-type: none"> • Soft, dark grey treaded, dual-wheel roll-control casters for use on hard floors 	<ul style="list-style-type: none"> Specify <i>with soft roll-control casters.</i>
Glides	<ul style="list-style-type: none"> • Glides: plastic 	<ul style="list-style-type: none"> Specify <i>with glides.</i>
CarbonNeutral Product	<ul style="list-style-type: none"> • CarbonNeutral product certification 	<ul style="list-style-type: none"> Add CN suffix.

Tip: Suffix **CN** will be added after **S** if CarbonNeutral is selected.

Specification Information
• Style Number : : :
46267179 : :

Leap 462 Series Stool

3D Knit on Back with Upholstery on Seat

Leap 462 Series Stool



Standard Includes		Required to Specify
<ul style="list-style-type: none"> ▶ See <i>Seating Specification Guide</i> for product details. 	<ul style="list-style-type: none"> • Upper back force • 8" pneumatic seat-height adjustment • Variable back stop • Lower back firmness • Passive seat edge angle • Rectilinear independent height-, width-, pivot-, and depth-adjustable arms and soft arm caps, if selected: black plastic • Frame, seat shell, outer back, and five-arm base: plastic • Column and 4" adjustable foot ring: black • 3D Knit on back only • 3" seat depth adjustment • Adjustable lumbar • Standard upholstery design on seat: fabric price group 1 • 2"-diameter, hard-composition, dual-wheel casters: black 	<ol style="list-style-type: none"> 1 Style number 2 Plastic color for frame, seat shell, outer back, and base 3 3D Knit color for back 4 Fabric color number for upholstery on seat 5 Options, if selected (see below) <ul style="list-style-type: none"> ▶ See <i>Surface Materials</i>, page 480.

Options		Required to Specify
Surface Materials	Upholstery <ul style="list-style-type: none"> • Fabric price group 1 • Fabric price group 2 • Fabric price group 3 • Fabric price group 5 • Fabric price group 6 • Steelcase vinyl 	Specify fabric color number. Specify fabric color number. Specify fabric color number. Specify fabric color number. Specify fabric color number. Add suffix S to the style number and specify vinyl color number.
	Sewn upholstery <ul style="list-style-type: none"> • Sewn upholstery on chair 	Add suffix S to the style number.
	Platinum/midnight <ul style="list-style-type: none"> • On frame, base, arm retainer, and outer back 	Specify with <i>6249 Platinum</i> or with <i>6259 Midnight</i> .
Arms	<ul style="list-style-type: none"> • Height-adjustable arms, soft arm caps • Armless 	Specify with <i>height-adjustable arms</i> Specify <i>without arms</i> .
Lumbar	<ul style="list-style-type: none"> • Without lumbar 	Specify <i>without lumbar</i> .
Casters	<ul style="list-style-type: none"> • Soft, dark grey treaded, dual-wheel roll-control casters for use on hard floors 	Specify with <i>soft roll-control casters</i> .
Glides	<ul style="list-style-type: none"> • Glides: plastic 	Specify with <i>glides</i> .
CarbonNeutral Product	<ul style="list-style-type: none"> • CarbonNeutral product certification 	Add CN suffix.

Tip: Suffix **CN** will be added after **S** if CarbonNeutral is selected.

Specification Information	
Style Number	
46267189	

Work Chairs

Leap Plus 462 Series Work Chair

Upholstery on Back and Seat



	Standard Includes	Required to Specify
<p>▶ See <i>Seating Specification Guide</i> for product details.</p>	<ul style="list-style-type: none"> • Upper back force • 4" pneumatic seat-height adjustment • Variable back stop • Lower back firmness • Rectilinear independent height-, width-, pivot-, and depth- adjustable arms and soft arm caps, if selected: black plastic • Frame, seat shell, outer back, and five-arm base: plastic • 2" seat depth adjustment • Adjustable lumbar • Standard upholstery design: fabric price group 1 • 2½"-diameter, hard-composition, dual-wheel casters: black 	<ol style="list-style-type: none"> 1 Style number 2 Plastic color for frame, seat shell, outer back, and base 3 Fabric color number for upholstery on seat and back 4 Options, if selected (see below) <p>▶ See <i>Surface Materials</i>, page 480.</p>

	Options	Required to Specify
Surface Materials	<p>Upholstery on seat and back</p> <ul style="list-style-type: none"> • Fabric price group 1 • Fabric price group 2 • Fabric price group 3 • Fabric price group 5 • Fabric price group 6 • Steelcase vinyl 	<p>Specify fabric color number. Specify fabric color number. Specify fabric color number. Specify fabric color number. Specify fabric color number. Add S to the style number suffix and specify vinyl color number.</p>
	<p>Sewn upholstery</p> <ul style="list-style-type: none"> • Sewn upholstery on chair 	<p>Add S suffix.</p>
	<p>Platinum/midnight</p> <ul style="list-style-type: none"> • On frame, base, arm retainer, and outer back 	<p>Specify <i>with 6249 Platinum</i> or <i>with 6259 Midnight</i>.</p>
Arms	<ul style="list-style-type: none"> • Height-adjustable arms, soft arm caps • Armless 	<p>Specify <i>with height-adjustable arms</i>. Specify <i>without arms</i>.</p>
Seat Height	<ul style="list-style-type: none"> • 5" pneumatic seat-height adjustment 	<p>Specify <i>with 5" pneumatic seat-height adjustment</i>.</p>
Lumbar	<ul style="list-style-type: none"> • Without lumbar 	<p>Specify <i>without lumbar</i>.</p>
Casters	<ul style="list-style-type: none"> • Soft, dark grey treaded, dual-wheel roll-control casters for use on hard floors 	<p>Specify <i>with soft roll-control casters</i>.</p>
Glides	<ul style="list-style-type: none"> • Glides: plastic 	<p>Specify <i>with glides</i>.</p>

Specification Information
<p>• Style Number</p> <hr/> <p>46296179</p>

Leap Plus 462 Series Work Chair

3D Knit on Back with Upholstery on Seat

Leap Plus 462 Series
Work Chair



Standard Includes		Required to Specify
<ul style="list-style-type: none"> ▶ See <i>Seating Specification Guide</i> for product details. 	<ul style="list-style-type: none"> • Upper back force • 4" pneumatic seat-height adjustment • Variable back stop • Lower back firmness • Rectilinear independent height-, width-, pivot-, and depth- adjustable arms and soft arm caps, if selected: black plastic • Frame, seat shell, outer back, and five-arm base: plastic • 2" seat depth adjustment • Adjustable lumbar • 3D Knit on back only • Standard upholstery design on seat: fabric price group 1 • 2½"-diameter, hard-composition, dual-wheel casters: black 	<ol style="list-style-type: none"> 1 Style number 2 Plastic color for frame, seat shell, outer back, and base 3 3D Knit color for back 4 Fabric color number for upholstery on seat 5 Options, if selected (see below) <ul style="list-style-type: none"> ▶ See <i>Surface Materials</i>, page 480.

Options		Required to Specify
Surface Materials	<p>Upholstery on seat and back</p> <ul style="list-style-type: none"> • Fabric price group 1 • Fabric price group 2 • Fabric price group 3 • Fabric price group 5 • Fabric price group 6 • Steelcase vinyl <p>Sewn upholstery</p> <ul style="list-style-type: none"> • Sewn upholstery on chair <p>Platinum/midnight</p> <ul style="list-style-type: none"> • On frame, base, arm retainer, and outer back 	<p>Specify fabric color number. Specify fabric color number. Specify fabric color number. Specify fabric color number. Specify fabric color number. Add S to the style number suffix and specify vinyl color number.</p> <p>Add S suffix.</p> <p>Specify with <i>6249 Platinum</i> or with <i>6259 Midnight</i>.</p>
Arms	<ul style="list-style-type: none"> • Height-adjustable arms, soft arm caps • Armless 	<p>Specify with <i>height-adjustable arms</i>.</p> <p>Specify <i>without arms</i>.</p>
Seat Height	<ul style="list-style-type: none"> • 5" pneumatic seat-height adjustment 	<p>Specify with <i>5" pneumatic seat-height adjustment</i>.</p>
Lumbar	<ul style="list-style-type: none"> • Without lumbar 	<p>Specify <i>without lumbar</i>.</p>
Casters	<ul style="list-style-type: none"> • Soft, dark grey treaded, dual-wheel roll-control casters for use on hard floors 	<p>Specify with <i>soft roll-control casters</i>.</p>
Glides	<ul style="list-style-type: none"> • Glides: plastic 	<p>Specify with <i>glides</i>.</p>

Tip: When glides are specified, chairs will ship with casters installed and glides provided to install after delivery.

Specification Information	
Style Number	
46296189	

Work Chairs

Think 465 Series Work Chair

3D Knit Back with Upholstery on Seat



	Standard Includes	Required to Specify
▶ See <i>Seating Specification Guide</i> for product details.	<ul style="list-style-type: none"> 5" pneumatic seat-height adjustment (16½"–21½") Passive seat edge angle Frame, seat shell, and five-arm plastic base: black 2½" seat depth adjustment Rectilinear height-, width-, pivot-, and depth-adjustable arms Adjustable lumbar 3D Knit on back Standard upholstery design on seat: fabric price group 1 2½"-diameter, hard-composition, dual-wheel casters: black 	<ol style="list-style-type: none"> Style number Color scheme: monochromatic or contrasting (see below under Required Selections) Finish color for frame, base, and arm retainer 3D Knit color for back Fabric color number for upholstery on seat Options, if selected (see below) <p>▶ See <i>Surface Materials</i>, page 480.</p>

	Required Selections	Required to Specify
Color Scheme/ Frame Package	Monochromatic	
	<ul style="list-style-type: none"> Black Merle Platinum metallic 	Specify with 6205 Black. Specify with 7360 Merle. Specify with 4799 Platinum Metallic.
	Contrasting	
	<ul style="list-style-type: none"> Platinum metallic 	Specify with 4799 Platinum.

	Options	Required to Specify
Surface Materials	Upholstery on seat	
	<ul style="list-style-type: none"> Fabric price group 1 Fabric price group 2 Fabric price group 3 Fabric price group 5 Fabric price group 6 	Specify fabric color number. Specify fabric color number. Specify fabric color number. Specify fabric color number. Specify fabric color number.
	Base	
	<ul style="list-style-type: none"> Polished aluminum Merle Platinum metallic 	Specify with aluminum base. Specify with 7360 Merle base. Specify with 4799 Platinum Metallic base.
Arms	<ul style="list-style-type: none"> Height-adjustable arms Fixed arms Armless 	Specify with height-adjustable arms. Specify with fixed arms. Specify without arms.
Seat Height	<ul style="list-style-type: none"> 3" low-range pneumatic seat-height adjustment (14½"–17½") 7" high-range pneumatic seat-height adjustment (18"–25") 	Specify with low-range pneumatic seat-height adjustment. Specify with high-range pneumatic seat-height adjustment.
Coat Hanger	<ul style="list-style-type: none"> Coat hanger 	Specify with coat hanger.
Headrest	<ul style="list-style-type: none"> Headrest 	Specify with headrest.
Lumbar	<ul style="list-style-type: none"> Fixed lumbar support 	Specify with fixed lumbar height.
Casters	<ul style="list-style-type: none"> Soft, dark grey treaded, dual-wheel roll-control casters for use on hard floors 	Specify with soft roll-control casters.
Glides	<ul style="list-style-type: none"> Glides: plastic 	Specify with glides.
CarbonNeutral Product	<ul style="list-style-type: none"> CarbonNeutral product certification 	Add CN suffix.

Tip: Coat hanger option is not available on chairs with headrest.

Tip: Plastic shell on headrest is available in black only.

Tip: When glides are specified, chairs will ship with casters installed and glides provided to install after delivery.

Specification Information	
Style Number	
465A300	

Think 465 Series Work Chair

Upholstered Back with Upholstery on Seat



Standard Includes		Required to Specify
<ul style="list-style-type: none"> ▶ See <i>Seating Specification Guide</i> for product details. 	<ul style="list-style-type: none"> 5" pneumatic seat-height adjustment (16½"–21½") Passive seat edge angle Frame, seat shell, and five-arm plastic base: black 2½" seat depth adjustment Rectilinear height-, width-, pivot-, and depth-adjustable arms Adjustable lumbar Standard upholstery design: fabric price group 1 2½"-diameter, hard-composition, dual-wheel casters: black 	<ol style="list-style-type: none"> Style number Color scheme: monochromatic, or contrasting (see below under Required Selections) Finish color for frame, base, and arm retainer Fabric color number for upholstery on seat and back Outer back cover (see below under Required Selections) Options, if selected (see below) <ul style="list-style-type: none"> ▶ See <i>Surface Materials</i>, page 480.

Required Selections		Required to Specify
Color Scheme/Frame Package	Monochromatic	
	<ul style="list-style-type: none"> Black Merle Platinum metallic 	<ul style="list-style-type: none"> Specify with 6205 Black. Specify with 7360 Merle. Specify with 4799 Platinum Metallic.
Outer Back Cover	Contrasting	
	<ul style="list-style-type: none"> Platinum metallic 	<ul style="list-style-type: none"> Specify with 4799 Platinum.
Outer Back Cover	<ul style="list-style-type: none"> No back cover Fabric back cover 	<ul style="list-style-type: none"> Specify with no back cover. Specify with fabric back cover.

Options		Required to Specify
Surface Materials	Upholstery on seat and back	
	<ul style="list-style-type: none"> Fabric price group 1 Fabric price group 2 Fabric price group 3 Fabric price group 5 Fabric price group 6 	<ul style="list-style-type: none"> Specify fabric color number. Specify fabric color number. Specify fabric color number. Specify fabric color number. Specify fabric color number.
	Contrasting	
	<ul style="list-style-type: none"> Contrasting fabrics 	<ul style="list-style-type: none"> Specify with contrasting.
Surface Materials	Upholstery on seat	
	<ul style="list-style-type: none"> Fabric price group 1 Fabric price group 2 Fabric price group 3 Fabric price group 5 Fabric price group 6 	<ul style="list-style-type: none"> Specify fabric color number. Specify fabric color number. Specify fabric color number. Specify fabric color number. Specify fabric color number.
	Upholstery on back	
	<ul style="list-style-type: none"> Fabric price group 1 Fabric price group 2 Fabric price group 3 Fabric price group 5 Fabric price group 6 	<ul style="list-style-type: none"> Specify fabric color number. Specify fabric color number. Specify fabric color number. Specify fabric color number. Specify fabric color number.
Surface Materials	Upholstery on optional back cover	
	<ul style="list-style-type: none"> Fabric price group 1 Fabric price group 2 Fabric price group 3 Fabric price group 5 Fabric price group 6 	<ul style="list-style-type: none"> Specify fabric color number. Specify fabric color number. Specify fabric color number. Specify fabric color number. Specify fabric color number.
	Contrasting upholstery on seat	
	<ul style="list-style-type: none"> Fabric price group 1 Fabric price group 2 Fabric price group 3 Fabric price group 5 Fabric price group 6 	<ul style="list-style-type: none"> Specify fabric color number. Specify fabric color number. Specify fabric color number. Specify fabric color number. Specify fabric color number.

Tip: Back cover fabric defaults to match the seat back fabric specified.

Tip: Optional outer back cover is available in fabric and Brisa. Back cover is not available in vinyl.

▶ Options, continued on next page

► Options, continued from previous page

Options		Required to Specify
Surface Materials, continued	Base <ul style="list-style-type: none"> Polished aluminum Merle Platinum metallic 	Specify with aluminum base. Specify with 7360 Merle base. Specify with 4799 Platinum Metallic base.
Arms	<ul style="list-style-type: none"> Height-adjustable arms Fixed arms Armless 	Specify with height-adjustable arms. Specify with fixed arms. Specify without arms.
Seat Height	<ul style="list-style-type: none"> 3" low-range pneumatic seat-height adjustment (14¹/₂"–17¹/₂") 7" high-range pneumatic seat-height adjustment (18"–25") 	Specify with low-range pneumatic seat-height adjustment. Specify with high-range pneumatic seat-height adjustment.
Coat Hanger	<ul style="list-style-type: none"> Coat hanger 	Specify with coat hanger.
Headrest	<ul style="list-style-type: none"> Headrest 	Specify with headrest.
Lumbar	<ul style="list-style-type: none"> Fixed lumbar support 	Specify with fixed lumbar height.
Casters	<ul style="list-style-type: none"> Soft, dark grey treaded, dual-wheel roll-control casters for use on hard floors 	Specify with soft roll-control casters.
Glides	<ul style="list-style-type: none"> Glides: plastic 	Specify with glides.
CarbonNeutral Product	<ul style="list-style-type: none"> CarbonNeutral product certification 	Add CN suffix.

Tip: Coat hanger option is not available on chairs with headrest.

Tip: Plastic shell on headrest is available in black only.

Tip: When glides are specified, chairs will ship with casters installed and glides provided to install after delivery.



Specification Information

• **Style Number**

465A000

Work Chairs

Think 465 Series Stool

3D Knit Back with Upholstery on Seat



	Standard Includes	Required to Specify
▶ See <i>Seating Specification Guide</i> for product details.	<ul style="list-style-type: none"> • 10" pneumatic seat-height adjustment (22½"–32½") • Passive seat edge angle • Frame, seat shell, and five-arm base: black • 2½" seat depth adjustment • Rectilinear height-, width-, pivot-, and depth-adjustable arms • Column and adjustable foot ring: black • Adjustable lumbar • 3D Knit on back • Standard upholstery design on seat: fabric price group 1 • 2½"-diameter, hard-composition, dual-wheel casters: black 	<ol style="list-style-type: none"> 1 Style number 2 Color scheme: monochromatic or contrasting (see below under Required Selections) 3 Finish color for frame, base, and arm retainer 4 3D Knit color for back 5 Fabric color number for upholstery on seat 6 Options, if selected (see below) <p>▶ See <i>Surface Materials</i>, page 480.</p>

	Required Selections	Required to Specify
Color Scheme/ Frame Package	Monochromatic <ul style="list-style-type: none"> • Black • Merle • Platinum metallic 	Specify with 6205 Black. Specify with 7360 Merle. Specify with 4799 Platinum Metallic.
	Contrasting <ul style="list-style-type: none"> • Platinum metallic 	Specify with 4799 Platinum Metallic.

	Options	Required to Specify
Surface Materials	Upholstery on seat <ul style="list-style-type: none"> • Fabric price group 1 • Fabric price group 2 • Fabric price group 3 • Fabric price group 5 • Fabric price group 6 	Specify fabric color number. Specify fabric color number. Specify fabric color number. Specify fabric color number. Specify fabric color number.
	Base <ul style="list-style-type: none"> • Polished aluminum • Merle • Platinum metallic 	Specify with aluminum base. Specify with 7360 Merle base. Specify with 4799 Platinum Metallic base.
Arms	<ul style="list-style-type: none"> • Height-adjustable arms • Fixed arms • Armless 	Specify with height-adjustable arms. Specify with fixed arms. Specify without arms.
Lumbar	<ul style="list-style-type: none"> • Fixed lumbar support 	Specify with fixed lumbar height.
Casters	<ul style="list-style-type: none"> • Soft, dark grey treaded, dual-wheel roll-control casters for use on hard floors 	Specify with soft roll-control casters.
Glides	<ul style="list-style-type: none"> • Glides: plastic 	Specify with glides.
CarbonNeutral Product	<ul style="list-style-type: none"> • CarbonNeutral product certification 	Add suffix CN to the end of the style number.

Specification Information	
Style Number	
465B300	

Think 465 Series Stool

Upholstered Back with Upholstery on Seat



	Standard Includes	Required to Specify
▶ See <i>Seating Specification Guide</i> for product details.	<ul style="list-style-type: none"> 10" pneumatic seat-height adjustment (22½"-32½") Passive seat edge angle Frame, seat shell, and five-arm base: black 2½" seat depth adjustment Rectilinear height-, width-, pivot-, and depth-adjustable arms Column and adjustable foot ring: black Adjustable lumbar Standard upholstery design: fabric price group 1 2½"-diameter, hard-composition, dual-wheel casters: black 	<ol style="list-style-type: none"> Style number Color scheme: monochromatic or contrasting, (see below under required Selections) Finish color for frame, base, and arm retainer Fabric color number for upholstery on seat and back Outer back cover (see below under Required Selections) Options, if selected (see below) <p>▶ See <i>Surface Materials</i>, page 480.</p>

	Required Selections	Required to Specify
Color Scheme/ Frame Package	Monochromatic <ul style="list-style-type: none"> Black Merle Platinum metallic 	Specify with 6205 Black. Specify with 7360 Merle. Specify with 4799 Platinum Metallic.
	Contrasting <ul style="list-style-type: none"> Platinum metallic 	Specify with 4799 Platinum.
Outer Back Cover	<ul style="list-style-type: none"> No back cover Fabric back cover 	Specify with no back cover. Specify with fabric back cover.

	Options	Required to Specify
Surface Materials	Upholstery on seat and back <ul style="list-style-type: none"> Fabric price group 1 Fabric price group 2 Fabric price group 3 Fabric price group 5 Fabric price group 6 	Specify fabric color number. Specify fabric color number. Specify fabric color number. Specify fabric color number. Specify fabric color number.
	Contrasting <ul style="list-style-type: none"> Contrasting fabrics 	Specify with contrasting.
	Upholstery on seat <ul style="list-style-type: none"> Fabric price group 1 Fabric price group 2 Fabric price group 3 Fabric price group 5 Fabric price group 6 	Specify fabric color number. Specify fabric color number. Specify fabric color number. Specify fabric color number. Specify fabric color number.
	Upholstery on back <ul style="list-style-type: none"> Fabric price group 1 Fabric price group 2 Fabric price group 3 Fabric price group 5 Fabric price group 6 	Specify fabric color number. Specify fabric color number. Specify fabric color number. Specify fabric color number. Specify fabric color number.
	Upholstery on optional back cover <ul style="list-style-type: none"> Fabric price group 1 Fabric price group 2 Fabric price group 3 Fabric price group 5 Fabric price group 6 	Specify fabric color number. Specify fabric color number. Specify fabric color number. Specify fabric color number. Specify fabric color number.
	Base <ul style="list-style-type: none"> Polished aluminum Merle Platinum metallic 	Specify with aluminum base. Specify with 7360 Merle base. Specify with 4799 Platinum Metallic base.

Tip: Back cover fabric defaults to match the seat back fabric specified.

Tip: Optional outer back cover is available in fabric and Brisa. Back cover is not available in vinyl.

▶ Options, continued on next page

► Options, continued from previous page

Options		Required to Specify
Arms	<ul style="list-style-type: none"> • Height-adjustable arms • Fixed arms • Armless 	Specify with <i>height-adjustable arms</i> . Specify with <i>fixed arms</i> . Specify <i>without arms</i> .
Lumbar	<ul style="list-style-type: none"> • Fixed lumbar support 	Specify with <i>fixed lumbar height</i> .
Casters	<ul style="list-style-type: none"> • Soft, dark grey treaded, dual-wheel roll-control casters for use on hard floors 	Specify with <i>soft roll-control casters</i> .
Glides	<ul style="list-style-type: none"> • Glides: plastic 	Specify with <i>glides</i> .
CarbonNeutral Product	<ul style="list-style-type: none"> • CarbonNeutral product certification 	Add CN suffix.

Tip: When glides are specified, stools will ship with casters installed and glides provided to install after delivery.



Specification Information

• **Style Number**

465B000

Amia 482 Series Work Chair

Upholstery on Seat and Back



Tip: Frame packages include outer back shell, outer back frame, arm holsters, outer seat shell, and base.

Tip: When merle, platinum, or seagull are selected as frame packages, the outer seat shell and inner back frame default to 6527 Merle plastic.

Tip: When glides are specified, chairs will ship with casters installed and glides provided to install after delivery.

Tip: Suffix **CN** will be added after **S** if CarbonNeutral is selected.

Standard Includes		Required to Specify
<ul style="list-style-type: none"> ▶ See <i>Seating Specification Guide</i> for product details. 	<ul style="list-style-type: none"> • Frame package color scheme: black • Synchro-tilt mechanism • 5" pneumatic seat-height adjustment • Upright back lock • Rectilinear independent height-, width-, pivot-, and depth-adjustable arms and soft arm caps: black plastic • 3" seat depth adjustment • Passive seat edge angle • Adjustable lumbar • Standard upholstery design: fabric price group 1 • 2½"-diameter, hard-composition, dual-wheel casters: black 	<ol style="list-style-type: none"> 1 Style number 2 Frame package color scheme (see below under Required Selections) 3 Fabric color number for upholstery on seat and back 4 Options, if selected (see below) <ul style="list-style-type: none"> ▶ See <i>Surface Materials</i>, page 480.

Required Selections	Required to Specify
Frame Package Color Scheme <ul style="list-style-type: none"> • Black • Merle • Platinum solid • Seagull 	Specify with 6205 Black. Specify with 6527 Merle. Specify with 6249 Platinum Solid. Specify with 6053 Seagull.

Options	Required to Specify
Surface Materials <ul style="list-style-type: none"> • Fabric price group 1 • Fabric price group 2 • Fabric price group 3 • Fabric price group 5 • Fabric price group 6 • Steelcase vinyl 	Upholstery on seat and back <ul style="list-style-type: none"> Specify fabric color number. Specify fabric color number. Specify fabric color number. Specify fabric color number. Specify fabric color number. Add S to the style number and specify vinyl color number.
Sewn upholstery <ul style="list-style-type: none"> • Sewn upholstery on chair 	Add S suffix.
Fully upholstered <ul style="list-style-type: none"> • Fully upholstered with fabric 	Add U suffix.
Base <ul style="list-style-type: none"> • Polished aluminum base 	Specify with <i>polished aluminum base</i> .
Arms <ul style="list-style-type: none"> • Height-adjustable arms, soft arm caps • Armless 	Specify with <i>height-adjustable arms</i> . Specify <i>without arms</i> .
Seat Height <ul style="list-style-type: none"> • 5" pneumatic seat-height adjustment • 7" pneumatic seat-height adjustment 	Specify with <i>5" pneumatic seat-height adjustment</i> . Specify with <i>7" pneumatic seat-height adjustment</i> .
Casters <ul style="list-style-type: none"> • Soft, dark grey treaded, dual-wheel roll-control casters for use on hard floors • Hard, polished aluminum casters on polished aluminum base for use on soft floors • Soft, polished aluminum casters on polished aluminum base for use on hard floors 	Specify with <i>soft roll-control casters</i> . Specify with <i>hard polished aluminum casters</i> . Specify with <i>soft polished aluminum casters</i> .
Glides <ul style="list-style-type: none"> • Glides: plastic 	Specify with <i>glides</i> .
CarbonNeutral Product <ul style="list-style-type: none"> • CarbonNeutral product certification 	Add CN suffix.

Specification Information
Style Number : : 4821410 : :

Amia 482 Series Work Chair

3D Knit on Back with Upholstery on Seat

Amia 482 Series
Work Chair



Tip: Frame packages include outer back shell, outer back frame, arm holsters, outer seat shell, and base.

Tip: When glides are specified, chairs will ship with casters installed and glides provided to install after delivery.

*Tip: Suffix **CN** will be added after **S** if CarbonNeutral is selected.*

Standard Includes		Required to Specify
<ul style="list-style-type: none"> ▶ See <i>Seating Specification Guide</i> for product details. 	<ul style="list-style-type: none"> • Frame package color scheme: black • Synchro-tilt mechanism • 5" pneumatic seat-height adjustment • Upright back lock • Rectilinear independent height-, width-, pivot-, and depth-adjustable arms and soft arm caps: black plastic • 3" seat depth adjustment • Passive seat edge angle • Height-adjustable lumbar • 3D Knit on back only • Standard upholstery design on seat: fabric price group 1 • 2½"-diameter, hard-composition, dual-wheel casters: black 	<ol style="list-style-type: none"> 1 Style number 2 Frame package color scheme (see below under Required Selections) 3 3D Knit color for back 4 Fabric color number for upholstery on seat 5 Options, if selected (see below) <ul style="list-style-type: none"> ▶ See <i>Surface Materials</i>, page 480.

Required Selections		Required to Specify
Frame Package Color Scheme	<ul style="list-style-type: none"> • Black • Merle • Platinum solid • Seagull 	Specify with <i>6205 Black</i> . Specify with <i>6527 Merle</i> . Specify with <i>6249 Platinum Solid</i> . Specify with <i>6053 Seagull</i> .

Options		Required to Specify
Surface Materials	Upholstery <ul style="list-style-type: none"> • Fabric price group 1 • Fabric price group 2 • Fabric price group 3 • Fabric price group 5 • Fabric price group 6 • Steelcase vinyl 	Specify fabric color number. Specify fabric color number. Specify fabric color number. Specify fabric color number. Specify fabric color number. Add S to the style number and specify vinyl color number.
	Sewn upholstery <ul style="list-style-type: none"> • Sewn upholstery on chair 	Add S suffix.
Base	<ul style="list-style-type: none"> • Polished aluminum base 	Specify with <i>polished aluminum base</i> .
Arms	<ul style="list-style-type: none"> • Height-adjustable arms, soft arm caps • Armless 	Specify with <i>height-adjustable arms</i> . Specify <i>without arms</i> .
Seat Height	<ul style="list-style-type: none"> • 5" pneumatic seat-height adjustment • 7" pneumatic seat-height adjustment 	Specify with <i>5" pneumatic seat-height adjustment</i> . Specify with <i>7" pneumatic seat-height adjustment</i> .
Casters	<ul style="list-style-type: none"> • Soft, dark grey treaded, dual-wheel roll-control casters for use on hard floors • Hard, polished aluminum casters on polished aluminum base for use on soft floors • Soft, polished aluminum casters on polished aluminum base for use on hard floors 	Specify with <i>soft roll-control casters</i> . Specify with <i>hard polished aluminum casters</i> . Specify with <i>soft polished aluminum casters</i> .
Glides	<ul style="list-style-type: none"> • Glides: plastic 	Specify with <i>glides</i> .
CarbonNeutral Product	<ul style="list-style-type: none"> • CarbonNeutral product certification 	Add CN suffix.

Specification Information
Style Number : : 4821418 : :

Work Chairs

Amia 482 Series Work Chair

Air Back with 3D Microknit and Upholstery on Seat



Tip: Amia Air frame packages include inner back frame and lumbar, outer back frame, arm holsters, outer seat shell, and base.

Tip: When merle, platinum, or seagull are selected as frame packages, the outer seat shell and inner back frame default to 6527 Merle plastic.

Tip: When glides are specified, chairs will ship with casters installed and glides provided to install after delivery.

Tip: Suffix **CN** will be added after **S** if CarbonNeutral is selected.

Standard Includes		Required to Specify
<ul style="list-style-type: none"> ▶ See <i>Seating Specification Guide</i> for product details. 	<ul style="list-style-type: none"> • Frame package color scheme: black • Synchro-tilt mechanism • 5" pneumatic seat-height adjustment • Upright back lock • Rectilinear independent height-, width-, pivot-, and depth-adjustable arms and soft arm caps: black plastic • 3" seat depth adjustment • Passive seat edge angle • Air back with integrated Air LiveBack technology: plastic price groups 1 and 2 • Height-adjustable lumbar • 3D Microknit on back only • Standard upholstery design on seat: fabric price group 1 • 2½"-diameter, hard-composition, dual-wheel casters: black 	<ol style="list-style-type: none"> 1 Style number 2 Frame package color scheme (see below under Required Selections) 3 Fabric color number for upholstery on seat 4 Air back plastic color number 5 3D Microknit color number for back 6 Options, if selected (see below) <ul style="list-style-type: none"> ▶ See <i>Surface Materials</i>, page 480.

	Required Selections	Required to Specify
Frame Package Color Scheme	<ul style="list-style-type: none"> • Black • Merle • Platinum solid • Seagull 	Specify with 6205 Black. Specify with 6527 Merle. Specify with 6249 Platinum Solid. Specify with 6053 Seagull.

	Options	Required to Specify
Surface Materials	Upholstery <ul style="list-style-type: none"> • Fabric price group 1 • Fabric price group 2 • Fabric price group 3 • Fabric price group 5 • Fabric price group 6 • Steelcase vinyl 	Specify fabric color number. Specify fabric color number. Specify fabric color number. Specify fabric color number. Specify fabric color number. Add S to the style number and specify vinyl color number.
	Sewn upholstery <ul style="list-style-type: none"> • Sewn upholstery on chair 	Add S suffix.
Base	<ul style="list-style-type: none"> • Polished aluminum base 	Specify with <i>polished aluminum base</i> .
Arms	<ul style="list-style-type: none"> • Height-adjustable arms, soft arm caps • Armless 	Specify with <i>height-adjustable arms</i> . Specify <i>without arms</i> .
Lumbar	<ul style="list-style-type: none"> • No lumbar 	Specify with <i>no lumbar</i> .
Seat Height	<ul style="list-style-type: none"> • 5" pneumatic seat-height adjustment • 7" pneumatic seat-height adjustment 	Specify with <i>5" pneumatic seat-height adjustment</i> . Specify with <i>7" pneumatic seat-height adjustment</i> .
Casters	<ul style="list-style-type: none"> • Soft, dark grey treaded, dual-wheel roll-control casters for use on hard floors • Hard, polished aluminum casters on polished aluminum base for use on soft floors • Soft, polished aluminum casters on polished aluminum base for use on hard floors 	Specify with <i>soft roll-control casters</i> . Specify with <i>hard polished aluminum casters</i> . Specify with <i>soft polished aluminum casters</i> .
Glides	<ul style="list-style-type: none"> • Glides: plastic 	Specify with <i>glides</i> .
CarbonNeutral Product	<ul style="list-style-type: none"> • CarbonNeutral product certification 	Add CN suffix.

Specification Information	
Style Number	
4821414	

Amia 482 Series Work Chair

Air Back with Upholstery on Seat

Amia 482 Series
Work Chair



Tip: Frame packages include outer back shell, outer back frame, arm holsters, outer seat shell, and base.

Tip: When merle, platinum, or seagull are selected as frame packages, the outer seat shell and inner back frame default to 6527 Merle plastic.

Tip: When glides are specified, chairs will ship with casters installed and glides provided to install after delivery.

Tip: Suffix **CN** will be added after **S** if CarbonNeutral is selected.

Standard Includes		Required to Specify
<ul style="list-style-type: none"> ▶ See <i>Seating Specification Guide</i> for product details. 	<ul style="list-style-type: none"> Frame package color scheme: black Synchro-tilt mechanism 5" pneumatic seat-height adjustment Upright back lock Rectilinear independent height-, width-, pivot-, and depth-adjustable arms and soft arm caps: black plastic 3" seat depth adjustment Passive seat edge angle Air back with integrated Air LiveBack technology: plastic price groups 1 and 2 Standard upholstery design on seat: fabric price group 1 2 1/2"-diameter, hard-composition, dual-wheel casters: black 	<ol style="list-style-type: none"> Style number Frame package color scheme (see below under Required Selections) Fabric color number for upholstery on seat Air back plastic color number Options, if selected (see below) <ul style="list-style-type: none"> ▶ See <i>Surface Materials</i>, page 480.

Required Selections		Required to Specify
Frame Package Color Scheme	<ul style="list-style-type: none"> Black Merle Platinum solid Seagull 	Specify with 6205 Black . Specify with 6527 Merle . Specify with 6249 Platinum Solid . Specify with 6053 Seagull .

Options		Required to Specify
Surface Materials	Upholstery <ul style="list-style-type: none"> Fabric price group 1 Fabric price group 2 Fabric price group 3 Fabric price group 5 Fabric price group 6 Steelcase vinyl 	Specify fabric color number. Specify fabric color number. Specify fabric color number. Specify fabric color number. Specify fabric color number. Add S to the style number and specify vinyl color number.

	Sewn upholstery <ul style="list-style-type: none"> Sewn upholstery on chair 	Add S suffix.
--	---	----------------------

Base	<ul style="list-style-type: none"> Polished aluminum base 	Specify with <i>polished aluminum base</i> .
-------------	--	--

Arms	<ul style="list-style-type: none"> Height-adjustable arms, soft arm caps Armless 	Specify with <i>height-adjustable arms</i> . Specify <i>without arms</i> .
-------------	--	---

Seat Height	<ul style="list-style-type: none"> 5" pneumatic seat-height adjustment 7" pneumatic seat-height adjustment 	Specify with <i>5" pneumatic seat-height adjustment</i> . Specify with <i>7" pneumatic seat-height adjustment</i> .
--------------------	--	--

Casters	<ul style="list-style-type: none"> Soft, dark grey treaded, dual-wheel roll-control casters for use on hard floors Hard, polished aluminum casters on polished aluminum base for use on soft floors Soft, polished aluminum casters on polished aluminum base for use on hard floors 	Specify with <i>soft roll-control casters</i> . Specify with <i>hard polished aluminum casters</i> . Specify with <i>soft polished aluminum casters</i> .
----------------	---	---

Glides	<ul style="list-style-type: none"> Glides: plastic 	Specify with <i>glides</i> .
---------------	---	------------------------------

CarbonNeutral Product	<ul style="list-style-type: none"> CarbonNeutral product certification 	Add CN suffix.
------------------------------	---	-----------------------

Specification Information	
Style Number	4821412

Work Chairs

Amia 482 Series Stool

Upholstery on Seat and Back



Tip: Frame packages include outer back shell, outer back frame, arm holsters, outer seat shell, and base.

Tip: When glides are specified, chairs will ship with casters installed and glides provided to install after delivery.

Standard Includes		Required to Specify
<ul style="list-style-type: none"> ▶ See <i>Seating Specification Guide</i> for product details. 	<ul style="list-style-type: none"> • Frame package color scheme: black • Synchro-tilt mechanism • 8" pneumatic seat-height adjustment • Upright back lock • Passive seat edge angle • Rectilinear independent height-, width-, pivot-, and depth-adjustable arms and soft arm caps: black plastic • 3" seat depth adjustment • Column and 4" adjustable foot ring: black • Standard upholstery design: fabric price group 1 • 2"-diameter, hard-composition, dual-wheel casters: black • Adjustable lumbar 	<ol style="list-style-type: none"> 1 Style number 2 Frame package color scheme (see below under Required Selections) 3 Fabric color number for upholstery on seat and back 4 Options, if selected (see below) <ul style="list-style-type: none"> ▶ See <i>Surface Materials</i>, page 480.

Required Selections	Required to Specify
<p>Frame Package Color Scheme</p> <ul style="list-style-type: none"> • Black • Merle • Platinum solid • Seagull 	<p>Specify with 6205 <i>Black</i>. Specify with 6527 <i>Merle</i>. Specify with 6249 <i>Platinum Solid</i>. Specify with 6053 <i>Seagull</i>.</p>

Options	Required to Specify
<p>Surface Materials</p> <p>Upholstery on seat and back</p> <ul style="list-style-type: none"> • Fabric price group 1 • Fabric price group 2 • Fabric price group 3 • Fabric price group 5 • Fabric price group 6 • Steelcase vinyl 	<p>Specify fabric color number. Specify fabric color number. Specify fabric color number. Specify fabric color number. Specify fabric color number. Add S to the style number and specify vinyl color number.</p>
<p>Sewn upholstery</p> <ul style="list-style-type: none"> • Sewn upholstery on chair 	<p>Add S suffix.</p>
<p>Fully upholstered</p> <ul style="list-style-type: none"> • Fully upholstered with fabric 	<p>Add U suffix.</p>
<p>Arms</p> <ul style="list-style-type: none"> • Height-adjustable arms, soft arm caps • Armless 	<p>Specify with <i>height-adjustable arms</i>. Specify <i>without arms</i>.</p>
<p>Casters</p> <ul style="list-style-type: none"> • Soft, dark grey treaded, dual-wheel roll-control casters for use on hard floors 	<p>Specify with <i>soft roll-control casters</i>.</p>
<p>Glides</p> <ul style="list-style-type: none"> • Glides: plastic 	<p>Specify with <i>glides</i>.</p>

Specification Information
<p>• Style Number</p> <p>4827410</p>

Amia 482 Series Stool

3D Knit on Back with Upholstery on Seat

Amia 482 Series
Stool



Tip: Frame packages include outer back shell, outer back frame, arm holsters, outer seat shell, and base.

Tip: When glides are specified, stools will ship with casters installed and glides provided to install after delivery.

Standard Includes		Required to Specify
<ul style="list-style-type: none"> ▶ See <i>Seating Specification Guide</i> for product details. 	<ul style="list-style-type: none"> • Frame package color scheme: black • Synchro-tilt mechanism • 8" pneumatic seat-height adjustment • Upright back lock • Passive seat edge angle • Rectilinear independent height-, width-, pivot-, and depth-adjustable arms and soft arm caps: black plastic • 3" seat depth adjustment • Column and 4" adjustable foot ring: black • 3D Knit on back only • Standard upholstery design on seat: fabric price group 1 • 2"-diameter, hard-composition, dual-wheel casters: black • Adjustable lumbar 	<ol style="list-style-type: none"> 1 Style number 2 Frame package color scheme (see below under Required Selections) 3 3D Knit color for back 4 Fabric color number for upholstery on seat 5 Options, if selected (see below) <ul style="list-style-type: none"> ▶ See <i>Surface Materials</i>, page 480.

Required Selections	Required to Specify
Frame Package Color Scheme <ul style="list-style-type: none"> • Black • Merle • Platinum solid • Seagull 	<ul style="list-style-type: none"> Specify with 6205 <i>Black</i>. Specify with 6527 <i>Merle</i>. Specify with 6249 <i>Platinum Solid</i>. Specify with 6053 <i>Seagull</i>.

Options	Required to Specify
Surface Materials <ul style="list-style-type: none"> • Fabric price group 1 • Fabric price group 2 • Fabric price group 3 • Fabric price group 5 • Fabric price group 6 	<ul style="list-style-type: none"> Specify fabric color number. Specify fabric color number. Specify fabric color number. Specify fabric color number. Specify fabric color number.
Sewn upholstery <ul style="list-style-type: none"> • Sewn upholstery on chair 	
Arms <ul style="list-style-type: none"> • Height-adjustable arms, soft arm caps • Armless 	<ul style="list-style-type: none"> Specify with <i>height-adjustable arms</i>. Specify <i>without arms</i>.
Casters <ul style="list-style-type: none"> • Soft, dark grey treaded, dual-wheel roll-control casters for use on hard floors 	<ul style="list-style-type: none"> Specify with <i>soft roll-control casters</i>.
Glides <ul style="list-style-type: none"> • Glides: plastic 	<ul style="list-style-type: none"> Specify with <i>glides</i>.

Specification Information
<ul style="list-style-type: none"> • Style Number • •
4827418
<ul style="list-style-type: none"> • •

Work Chairs

Amia 482 Series Stool

Air Back with 3D Microknit and Upholstery on Seat



Tip: Amia Air frame packages include inner back frame and lumbar, outer back frame, arm holsters, outer seat shell, and base.

Tip: To specify a non-contrasting seat back, the air back plastic color finish and 3D Microknit color finish must be the same.

Tip: When glides are specified, stools will ship with casters installed and glides provided to install after delivery.

Standard Includes		Required to Specify
<ul style="list-style-type: none"> ▶ See <i>Seating Specification Guide</i> for product details. 	<ul style="list-style-type: none"> • Frame package color scheme: black • Synchro-tilt mechanism • 8" pneumatic seat-height adjustment • Upright back lock • Passive seat edge angle • Rectilinear independent height-, width-, pivot-, and depth-adjustable arms and soft arm caps: black plastic • 3" seat depth adjustment • Column and 4" adjustable foot ring: black • Air back with integrated Air LiveBack technology: plastic price groups 1 and 2 • Standard upholstery design on seat: fabric price group 1 • 2"-diameter, hard-composition, dual-wheel casters: black 	<ol style="list-style-type: none"> 1 Style number 2 Frame package color scheme (see below under Required Selections) 3 Fabric color number for upholstery on seat 4 Air back plastic color number 5 3D Microknit color number for back 6 Options, if selected (see below) <ul style="list-style-type: none"> ▶ See <i>Surface Materials</i>, page 480.

Required Selections	Required to Specify
Frame Package Color Scheme <ul style="list-style-type: none"> • Black • Merle • Platinum solid • Seagull 	Specify with 6205 Black. Specify with 6527 Merle. Specify with 6249 Platinum Solid. Specify with 6053 Seagull.

Options	Required to Specify
Surface Materials <ul style="list-style-type: none"> • Upholstery on seat and back <ul style="list-style-type: none"> • Fabric price group 1 • Fabric price group 2 • Fabric price group 3 • Fabric price group 5 • Fabric price group 6 • Steelcase vinyl 	Specify fabric color number. Specify fabric color number. Specify fabric color number. Specify fabric color number. Specify fabric color number. Add S to the style number and specify vinyl color number.
<ul style="list-style-type: none"> • Sewn upholstery <ul style="list-style-type: none"> • Sewn upholstery on chair 	Add S suffix.
Arms <ul style="list-style-type: none"> • Height-adjustable arms, soft arm caps • Armless 	Specify with height-adjustable arms. Specify without arms.
Casters <ul style="list-style-type: none"> • Soft, dark grey treaded, dual-wheel roll-control casters for use on hard floors 	Specify with soft roll-control casters.
Glides <ul style="list-style-type: none"> • Glides: plastic 	Specify with glides.

Specification Information
<ul style="list-style-type: none"> • Style Number
4827414

Amia 482 Series Stool

Air Back with Upholstery on Seat

Amia 482 Series
Stool



Tip: Amia Air frame packages include inner back frame and lumbar, outer back frame, arm holsters, outer seat shell, and base.

Tip: When merle, platinum, or seagull are selected as frame packages, the outer seat shell and inner back frame default to 6527 Merle plastic.

Tip: When glides are specified, stools will ship with casters installed and glides provided to install after delivery.

Standard Includes		Required to Specify
<ul style="list-style-type: none"> ▶ See <i>Seating Specification Guide</i> for product details. 	<ul style="list-style-type: none"> • Frame package color scheme: black • Synchro-tilt mechanism • 8" pneumatic seat-height adjustment • Upright back lock • Passive seat edge angle • Rectilinear independent height-, width-, pivot-, and depth-adjustable arms and soft arm caps: black plastic • 3" seat depth adjustment • Column and 4" adjustable foot ring: black • Air back with integrated Air LiveBack technology: plastic price groups 1 and 2 • Standard upholstery design on seat: fabric price group 1 • 2"-diameter, hard-composition, dual-wheel casters: black 	<ol style="list-style-type: none"> 1 Style number 2 Frame package color scheme (see below under Required Selections) 3 Fabric color number for upholstery on seat 4 Air back plastic color number 5 Options, if selected (see below) <p>▶ See <i>Surface Materials</i>, page 480.</p>

Required Selections	Required to Specify
Frame Package Color Scheme <ul style="list-style-type: none"> • Black • Merle • Platinum solid • Seagull 	Specify with <i>6205 Black</i> . Specify with <i>6527 Merle</i> . Specify with <i>6249 Platinum Solid</i> . Specify with <i>6053 Seagull</i> .

Options	Required to Specify
Surface Materials <ul style="list-style-type: none"> • Upholstery on seat and back <ul style="list-style-type: none"> • Fabric price group 1 • Fabric price group 2 • Fabric price group 3 • Fabric price group 5 • Fabric price group 6 • Steelcase vinyl • Sewn upholstery <ul style="list-style-type: none"> • Sewn upholstery on chair 	Specify fabric color number. Specify fabric color number. Specify fabric color number. Specify fabric color number. Specify fabric color number. Add S to the style number and specify vinyl color number.
Arms <ul style="list-style-type: none"> • Height-adjustable arms, soft arm caps • Armless 	Specify with <i>height-adjustable arms</i> . Specify <i>without arms</i> .
Casters <ul style="list-style-type: none"> • Soft, dark grey treaded, dual-wheel roll-control casters for use on hard floors 	Specify with <i>soft roll-control casters</i> .
Glides <ul style="list-style-type: none"> • Glides: plastic 	Specify with <i>glides</i> .

Specification Information
Style Number : : : 4827412 : :

Work Chairs

Steelcase Series 2 Work Chair

Air Back with Upholstery on Seat and Back



Tip: Steelcase Series 2 frame packages include inner back frame, lumbar, outer back frame, arm holsters, outer seat shell, and base.

Tip: When quilted back is selected, sewn seat is defaulted.

Tip: When back cover is selected, air back plastic color is automatically black because air back is not visible.

Standard Includes		Required to Specify
<ul style="list-style-type: none"> ▶ See <i>Seating Specification Guide</i> for product details. 	<ul style="list-style-type: none"> 5" pneumatic seat-height adjustment (16½"–21½") Frame package color scheme: black Base: 6205 Black plastic Standard upholstery design on seat and back: fabric price group 1 Air back with integrated Air LiveBack technology: plastic price groups 1 and 2 Rectilinear independent height-, width-, pivot-, and depth-adjustable arms and soft arm caps: black plastic 2½" seat depth adjustment Height-adjustable lumbar 2½" diameter, hard-composition, dual-wheel casters: black only 	<ol style="list-style-type: none"> Style number Frame package color scheme (see below under Required Selections) Back cover (see below under Required Selections) Quilted back (see below under Required Selections) Plastic color number for base Fabric color number for upholstery on seat and back Air back plastic color number, if selected Options, if selected (see below) <ul style="list-style-type: none"> ▶ See <i>Surface Materials</i>, page 480.

Required Selections		Required to Specify
Frame Package Color Scheme <ul style="list-style-type: none"> Black Sterling dark 		Specify <i>with black</i> . Specify <i>with sterling dark</i> .
Back Cover <ul style="list-style-type: none"> No back cover Fabric back cover 		Specify <i>with no back cover</i> . Specify <i>with fabric back cover</i> and select Cogent: Connect or Era fabric color number.
Quilted Back (Back Stitch Detail) <ul style="list-style-type: none"> No back quilting Quilted back 		Specify <i>with no stitch detail</i> . Specify <i>with quilted stitching</i> .

Options		Required to Specify
Surface Materials	Upholstery on seat and back <ul style="list-style-type: none"> Fabric price group 1 Fabric price group 2 Fabric price group 3 Fabric price group 5 Fabric price group 6 	Specify fabric color number. Specify fabric color number. Specify fabric color number. Specify fabric color number. Specify fabric color number.
	Contrasting upholstery on seat and back <ul style="list-style-type: none"> Contrasting fabrics 	Specify <i>with contrasting fabrics</i> .
	Contrasting upholstery on seat <ul style="list-style-type: none"> Fabric price group 1 Fabric price group 2 Fabric price group 3 Fabric price group 5 Fabric price group 6 	Specify fabric color number. Specify fabric color number. Specify fabric color number. Specify fabric color number. Specify fabric color number.
	Contrasting upholstery on back <ul style="list-style-type: none"> Fabric price group 1 Fabric price group 2 Fabric price group 3 Fabric price group 5 Fabric price group 6 	Specify fabric color number. Specify fabric color number. Specify fabric color number. Specify fabric color number. Specify fabric color number.
	Upholstery on headrest <ul style="list-style-type: none"> 3D Microknit Fabric price group 1 Fabric price group 2 Fabric price group 3 Fabric price group 5 Fabric price group 6 	Specify fabric color number. Specify fabric color number. Specify fabric color number. Specify fabric color number. Specify fabric color number.

▶ Options, continued on next page

► Options, continued from previous page

Options		Required to Specify
Base	<ul style="list-style-type: none"> Black Polished aluminum 	Specify with 6205 Black base. Specify with 8046 Polished Aluminum base.
Headrest	<ul style="list-style-type: none"> Headrest 	Specify with headrest.
Coat Hanger	<ul style="list-style-type: none"> Coat hanger 	Specify with coat hanger.
Lumbar	<ul style="list-style-type: none"> No lumbar 	Specify with no lumbar.
Arms	<ul style="list-style-type: none"> Height-only adjustable arms, soft arm caps Armless 	Specify with height-only adjustable arms. Specify without arms.
Seat Height	<ul style="list-style-type: none"> 3" short-range pneumatic seat-height adjustment 5" tall-range pneumatic seat-height adjustment 	Specify with short-range pneumatic seat-height adjustment. Specify with tall-range pneumatic seat-height adjustment.
Casters	<ul style="list-style-type: none"> Soft, dual-wheel roll-control casters for use on hard floors 	Specify with soft roll-control casters.
Glides	<ul style="list-style-type: none"> Plastic glides 	Specify with glides.
CarbonNeutral Product	<ul style="list-style-type: none"> CarbonNeutral product certification 	Add CN suffix.

Tip: Headrest and coat hanger can not be attached to a Steelcase Series 2 chair simultaneously.



Specification Information

• Style
• Number

436UPH

Work Chairs

Steelcase Series 2 Work Chair

Air Back with 3D Microknit and Upholstery on Seat



Tip: Plastic air back will match 3D Microknit unless contrasting is specified.

Tip: Steelcase Series 2 frame packages include inner back frame, lumbar, outer back frame, arm holsters, outer seat shell, and base.

Tip: Headrest and coat hanger can not be attached to a Steelcase Series 2 chair simultaneously.

Tip: When glides are specified, chairs will ship with casters installed and glides provided to install after delivery.

Standard Includes		Required to Specify
<ul style="list-style-type: none"> ▶ See <i>Seating Specification Guide</i> for product details. 	<ul style="list-style-type: none"> 5" pneumatic seat-height adjustment (16½"–21½") Frame package color scheme: black Base: 6205 Black plastic Back: 3D Microknit only Air back with integrated Air LiveBack technology: plastic price groups 1 and 2 Standard upholstery design on seat: fabric price group 1 Rectilinear independent height-, width-, pivot-, and depth-adjustable arms: black plastic 2½" seat depth adjustment Height-adjustable lumbar 2½"-diameter, hard-composition, dual-wheel casters: black only 	<ol style="list-style-type: none"> Style number Back color scheme (see below under Required Selections) Frame package color scheme (see below under Required Selections) Plastic color number for base 3D Microknit color number for back Air back plastic color number Fabric color number for upholstery on seat Options, if selected (see below) <ul style="list-style-type: none"> ▶ See <i>Surface Materials</i>, page 480.

Required Selections		Required to Specify
Back Color Scheme	<ul style="list-style-type: none"> Non-contrasting outer back Contrasting outer back 	Specify with <i>non-contrasting outer back</i> . Specify with <i>contrasting outer back</i> .

Frame Package Color Scheme	<ul style="list-style-type: none"> Black Sterling dark 	Specify with <i>black</i> . Specify with <i>sterling dark</i> .
-----------------------------------	--	--

Options		Required to Specify
---------	--	---------------------

Surface Materials	Upholstery on seat <ul style="list-style-type: none"> Fabric price group 1 Fabric price group 2 Fabric price group 3 Fabric price group 5 Fabric price group 6 	Specify fabric color number. Specify fabric color number. Specify fabric color number. Specify fabric color number. Specify fabric color number.
--------------------------	--	--

	Upholstery on headrest <ul style="list-style-type: none"> 3D Microknit Fabric price group 1 Fabric price group 2 Fabric price group 3 Fabric price group 5 Fabric price group 6 	Specify fabric color number. Specify fabric color number. Specify fabric color number. Specify fabric color number. Specify fabric color number. Specify fabric color number.
--	--	--

Base	<ul style="list-style-type: none"> Black Polished aluminum 	Specify with <i>6205 Black base</i> . Specify with <i>8046 Polished Aluminum base</i> .
-------------	--	--

Headrest	<ul style="list-style-type: none"> Headrest 	Specify with <i>headrest</i> .
-----------------	--	--------------------------------

Coat Hanger	<ul style="list-style-type: none"> Coat hanger 	Specify with <i>coat hanger</i> .
--------------------	---	-----------------------------------

Lumbar	<ul style="list-style-type: none"> No lumbar 	Specify with <i>no lumbar</i> .
---------------	---	---------------------------------

Arms	<ul style="list-style-type: none"> Height-only adjustable arms, soft arm caps Armless 	Specify with <i>height-only adjustable arms</i> . Specify <i>without arms</i> .
-------------	---	--

Seat Height	<ul style="list-style-type: none"> 3" short-range pneumatic seat-height adjustment 5" tall-range pneumatic seat-height adjustment 	Specify with <i>short-range pneumatic seat-height adjustment</i> . Specify with <i>tall-range pneumatic seat-height adjustment</i> .
--------------------	---	---

Casters	<ul style="list-style-type: none"> Soft, dual-wheel roll-control casters for use on hard floors 	Specify with <i>soft roll-control casters</i> .
----------------	--	---

Glides	<ul style="list-style-type: none"> Plastic glides 	Specify with <i>glides</i> .
---------------	--	------------------------------

CarbonNeutral Product	<ul style="list-style-type: none"> CarbonNeutral product certification 	Add CN suffix.
------------------------------	---	-----------------------

Specification Information

**Style
Number**

436AIR3D



Steelcase Series 2 Work Chair

Air Back with Upholstery on Seat



Tip: Steelcase Series 2 frame packages include inner back frame, lumbar, outer back frame, arm holsters, outer seat shell, and base.

Tip: Headrest and coat hanger can not be attached to a Steelcase Series 2 chair simultaneously.

Tip: When glides are specified, chairs will ship with casters installed and glides provided to install after delivery.

Standard Includes		Required to Specify
<ul style="list-style-type: none"> ▶ See <i>Seating Specification Guide</i> for product details. 	<ul style="list-style-type: none"> • 5" pneumatic seat-height adjustment (16½"–21½") • Frame package color scheme: black • Base: 6205 Black plastic • Rectilinear independent height-, width-, pivot-, and depth-adjustable arms and soft arm caps: black plastic • 2½" seat depth adjustment • Air back with integrated Air LiveBack technology: plastic price groups 1 and 2 • Standard upholstery design on seat: fabric price group 1 • 2½"-diameter, hard-composition, dual-wheel casters: black only 	<ol style="list-style-type: none"> 1 Style number 2 Frame package color scheme (see below under Required Selections) 3 Plastic color number for base 4 Air back plastic color number 5 Fabric color number for upholstery on seat 6 Options, if selected (see below) <ul style="list-style-type: none"> ▶ See <i>Surface Materials</i>, page 480.

Required Selections		Required to Specify
Frame Package Color Scheme <ul style="list-style-type: none"> • Black • Sterling dark 		Specify <i>with black</i> . Specify <i>with sterling dark</i> .

Options		Required to Specify
Surface Materials	Upholstery on seat <ul style="list-style-type: none"> • Fabric price group 1 • Fabric price group 2 • Fabric price group 3 • Fabric price group 5 • Fabric price group 6 	Specify fabric color number. Specify fabric color number. Specify fabric color number. Specify fabric color number. Specify fabric color number.
	Upholstery on headrest <ul style="list-style-type: none"> • 3D Microknit • Fabric price group 1 • Fabric price group 2 • Fabric price group 3 • Fabric price group 5 • Fabric price group 6 	Specify fabric color number. Specify fabric color number. Specify fabric color number. Specify fabric color number. Specify fabric color number. Specify fabric color number.
Base	<ul style="list-style-type: none"> • Black • Polished aluminum 	Specify <i>with 6205 Black base</i> . Specify <i>with 8046 Polished Aluminum base</i> .
Headrest	<ul style="list-style-type: none"> • Headrest 	Specify <i>with headrest</i> .
Coat Hanger	<ul style="list-style-type: none"> • Coat hanger 	Specify <i>with coat hanger</i> .
Arms	<ul style="list-style-type: none"> • Height-only adjustable arms, soft arm caps • Armless 	Specify <i>with height-only adjustable arms</i> . Specify <i>without arms</i> .
Seat Height	<ul style="list-style-type: none"> • 3" short-range pneumatic seat-height adjustment • 5" tall-range pneumatic seat-height adjustment 	Specify <i>with short-range pneumatic seat-height adjustment</i> . Specify <i>with tall-range pneumatic seat-height adjustment</i> .
Casters	<ul style="list-style-type: none"> • Soft, dual-wheel roll-control casters for use on hard floors 	Specify <i>with soft roll-control casters</i> .
Glides	<ul style="list-style-type: none"> • Plastic glides 	Specify <i>with glides</i> .
CarbonNeutral Product	<ul style="list-style-type: none"> • CarbonNeutral product certification 	Add CN suffix.

Specification Information

**Style
Number**

436AIR



Steelcase Series 2 Stool

Air Back with Upholstery on Seat and Back



Tip: Steelcase Series 2 frame packages include inner back frame, lumbar, outer back frame, arm holsters, outer seat shell, and base.

Tip: When back cover is selected, air back plastic color is automatically black because air back is not visible.

Tip: When quilted back is selected, sewn seat is defaulted.

Standard Includes		Required to Specify
<ul style="list-style-type: none"> ▶ See <i>Seating Specification Guide</i> for product details. 	<ul style="list-style-type: none"> • 7³/₄" pneumatic seat-height adjustment (23"-30³/₄" • Frame package color scheme: black • Base: 6205 Black plastic • Standard upholstery design on seat and back: fabric price group 1 • Air back with integrated live Air LiveBack technology: plastic price groups 1 and 2 • Rectilinear independent height-, width-, pivot-, and depth-adjustable arms and soft arm caps: black plastic • 2¹/₂" seat depth adjustment • Height-adjustable lumbar • Column and adjustable foot ring: black paint • 2¹/₂" diameter, hard-composition, dual-wheel casters: black only 	<ol style="list-style-type: none"> 1 Style number 2 Frame package color scheme (see below under Required Selections) 3 Plastic color number for base 4 Back cover (see below under Required Selections) 5 Quilted back (see below under Required Selections) 6 Fabric color number for upholstery on seat and back 7 Air back plastic color number, if selected 8 Options, if selected (see below) <ul style="list-style-type: none"> ▶ See <i>Surface Materials</i>, page 480.

Required Selections		Required to Specify
Frame Package Color Scheme <ul style="list-style-type: none"> • Black • Sterling dark 		Specify <i>with black</i> . Specify <i>with sterling dark</i> .
Back Cover <ul style="list-style-type: none"> • No back cover • Fabric back cover 		Specify <i>with no back cover</i> . Specify <i>with fabric back cover</i> and select Cogent: Connect or Era fabric color number.
Quilted Back (Back Stitch Detail) <ul style="list-style-type: none"> • No back quilting • Quilted back 		Specify <i>with no stitch detail</i> . Specify <i>with quilted stitching</i> .

Options		Required to Specify
Surface Materials	Upholstery on seat and back <ul style="list-style-type: none"> • Fabric price group 1 • Fabric price group 2 • Fabric price group 3 • Fabric price group 5 • Fabric price group 6 	Specify fabric color number. Specify fabric color number. Specify fabric color number. Specify fabric color number. Specify fabric color number.
	Contrasting upholstery on seat and back <ul style="list-style-type: none"> • Contrasting fabrics 	Specify <i>with contrasting fabrics</i> .
	Contrasting upholstery on seat <ul style="list-style-type: none"> • Fabric price group 1 • Fabric price group 2 • Fabric price group 3 • Fabric price group 5 • Fabric price group 6 	Specify fabric color number. Specify fabric color number. Specify fabric color number. Specify fabric color number. Specify fabric color number.
	Contrasting upholstery on back <ul style="list-style-type: none"> • Fabric price group 1 • Fabric price group 2 • Fabric price group 3 • Fabric price group 5 • Fabric price group 6 	Specify fabric color number. Specify fabric color number. Specify fabric color number. Specify fabric color number. Specify fabric color number.
	Upholstery on headrest <ul style="list-style-type: none"> • 3D Microknit • Fabric price group 1 • Fabric price group 2 • Fabric price group 3 • Fabric price group 5 • Fabric price group 6 	Specify fabric color number. Specify fabric color number. Specify fabric color number. Specify fabric color number. Specify fabric color number.

▶ Options, continued on next page

► Options, continued from previous page

Options		Required to Specify
Base	<ul style="list-style-type: none"> Black Polished aluminum base 	Specify with 6205 Black base. Specify with 8046 Polished Aluminum base.
Headrest	<ul style="list-style-type: none"> Headrest 	Specify with headrest.
Coat Hanger	<ul style="list-style-type: none"> Coat hanger 	Specify with coat hanger.
Lumbar	<ul style="list-style-type: none"> No lumbar 	Specify with no lumbar.
Arms	<ul style="list-style-type: none"> Height-only adjustable arms, soft arm caps Armless 	Specify with height-only adjustable arms. Specify without arms.
Casters	<ul style="list-style-type: none"> Soft, dual-wheel roll-control casters for use on hard floors 	Specify with soft roll-control casters.
Glides	<ul style="list-style-type: none"> Plastic glides 	Specify with glides.
CarbonNeutral Product	<ul style="list-style-type: none"> CarbonNeutral product certification 	Add CN suffix.

Tip: Headrest and coat hanger can not be attached to a Steelcase Series 2 chair simultaneously.



Specification Information

• **Style Number**

436UPHSTOOL

Steelcase Series 2 Stool

Air Back with 3D Microknit and Upholstery on Seat



Tip: Plastic air back will match 3D Microknit unless contrasting is specified.

Tip: Steelcase Series 2 frame packages include inner back frame, lumbar, outer back frame, arm holsters, outer seat shell, and base.

Tip: Headrest and coat hanger can not be attached to a Steelcase Series 2 chair simultaneously.

Tip: When glides are specified, stools will ship with casters installed and glides provided to install after delivery.

Standard Includes	Required to Specify
<ul style="list-style-type: none"> ▶ See <i>Seating Specification Guide</i> for product details. • 7³/₄" pneumatic seat-height adjustment (23"-30³/₄" • Frame package color scheme: black • Base: 6205 Black plastic • Back: 3D Microknit only • Air back with integrated Air LiveBack technology: plastic price groups 1 and 2 • Standard upholstery design on seat: fabric price group 1 • Rectilinear independent height-, width-, pivot-, and depth-adjustable arms and soft arm caps: black plastic • 2¹/₂" seat depth adjustment • Height-adjustable lumbar • Column and adjustable foot ring: black paint • 2¹/₂"-diameter, hard-composition, dual-wheel casters: black only 	<ol style="list-style-type: none"> 1 Style number 2 Back color scheme (see below under Required Selections) 3 Frame package color scheme (see below under Required Selections) 4 Plastic color number for base 5 3D Microknit color number for back 6 Air back plastic color number. 7 Fabric color number for upholstery on seat 8 Options, if selected (see below) <p>▶ See <i>Surface Materials</i>, page 480.</p>

Required Selections	Required to Specify
Back Color Scheme <ul style="list-style-type: none"> • Non-contrasting outer back • Contrasting outer back 	Specify with <i>non-contrasting outer back</i> . Specify with <i>contrasting outer back</i> .
Frame Package Color Scheme <ul style="list-style-type: none"> • Black • Sterling dark 	Specify with <i>black</i> . Specify with <i>sterling dark</i> .

Options	Required to Specify
Surface Materials <ul style="list-style-type: none"> • Upholstery on seat <ul style="list-style-type: none"> • Fabric price group 1 • Fabric price group 2 • Fabric price group 3 • Fabric price group 5 • Fabric price group 6 • Upholstery on headrest <ul style="list-style-type: none"> • 3D Microknit • Fabric price group 1 • Fabric price group 2 • Fabric price group 3 • Fabric price group 5 • Fabric price group 6 	Specify fabric color number. Specify fabric color number. Specify fabric color number. Specify fabric color number. Specify fabric color number. Specify fabric color number. Specify fabric color number. Specify fabric color number.
Base <ul style="list-style-type: none"> • Black • Polished aluminum 	Specify with <i>6205 Black base</i> . Specify with <i>8046 Polished Aluminum base</i> .
Headrest <ul style="list-style-type: none"> • Headrest 	Specify with <i>headrest</i> .
Coat Hanger <ul style="list-style-type: none"> • Coat hanger 	Specify with <i>coat hanger</i> .
Lumbar <ul style="list-style-type: none"> • No lumbar 	Specify with <i>no lumbar</i> .
Arms <ul style="list-style-type: none"> • Height-only adjustable arms, soft arm caps • Armless 	Specify with <i>height-only adjustable arms</i> . Specify <i>without arms</i> .
Casters <ul style="list-style-type: none"> • Soft, dual-wheel roll-control casters for use on hard floors 	Specify with <i>soft roll-control casters</i> .
Glides <ul style="list-style-type: none"> • Plastic 	Specify with <i>glides</i> .
CarbonNeutral Product <ul style="list-style-type: none"> • CarbonNeutral product certification 	Add CN suffix.

Specification Information

**Style
Number**

436AIR3DSTOOL

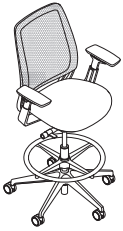

Steelcase Series 2 Stool

Air Back with Upholstery on Seat



Tip: Steelcase Series 2 frame packages include inner back frame, lumbar, outer back frame, arm holsters, outer seat shell, and base.

Tip: Stool ring is always black for lower cleaning maintenance.

Tip: Headrest and coat hanger can not be attached to a Steelcase Series 2 chair simultaneously.

Tip: When glides are specified, stools will ship with casters installed and glides provided to install after delivery.

Standard Includes		Required to Specify
<ul style="list-style-type: none"> ▶ See <i>Seating Specification Guide</i> for product details. 	<ul style="list-style-type: none"> • 7³/₄" pneumatic seat-height adjustment (23"-30³/₄") • Frame package color scheme: black • Base: 6205 Black plastic • Rectilinear independent height-, width-, pivot-, and depth-adjustable arms and soft arm caps: black plastic • 2¹/₂" seat depth adjustment • Column and adjustable foot ring: black paint • Air back with integrated live Air LiveBack technology: plastic price groups 1 and 2 • Standard upholstery design on seat: fabric price group 1 • 2¹/₂"-diameter, hard-composition, dual-wheel casters: black only 	<ol style="list-style-type: none"> 1 Style number 2 Frame package color scheme (see below under Required Selections) 3 Plastic color number for base 4 Air back plastic color number 5 Fabric color number for upholstery on seat 6 Options, if selected (see below) <ul style="list-style-type: none"> ▶ See <i>Surface Materials</i>, page 480.

Required Selections		Required to Specify
Frame Package Color Scheme	<ul style="list-style-type: none"> • Black • Sterling dark 	Specify <i>with black</i> . Specify <i>with sterling dark</i> .

Options		Required to Specify
Surface Materials	Upholstery on seat <ul style="list-style-type: none"> • Fabric price group 1 • Fabric price group 2 • Fabric price group 3 • Fabric price group 5 • Fabric price group 6 Upholstery on headrest <ul style="list-style-type: none"> • 3D Microknit • Fabric price group 1 • Fabric price group 2 • Fabric price group 3 • Fabric price group 5 • Fabric price group 6 	Specify fabric color number. Specify fabric color number. Specify fabric color number. Specify fabric color number. Specify fabric color number. Specify fabric color number.
Base	<ul style="list-style-type: none"> • Black • Polished aluminum 	Specify <i>with 6205 Black base</i> . Specify <i>with 8046 Polished Aluminum base</i> .
Headrest	<ul style="list-style-type: none"> • Headrest 	Specify <i>with headrest</i> .
Coat Hanger	<ul style="list-style-type: none"> • Coat hanger 	Specify <i>with coat hanger</i> .
Arms	<ul style="list-style-type: none"> • Height-only adjustable arms, soft arm caps • Armless 	Specify <i>with height-only adjustable arms</i> . Specify <i>without arms</i> .
Castors	<ul style="list-style-type: none"> • Soft, dual-wheel roll-control casters for use on hard floors 	Specify <i>with soft roll-control casters</i> .
Glides	<ul style="list-style-type: none"> • Plastic glides 	Specify <i>with glides</i> .
CarbonNeutral Product	<ul style="list-style-type: none"> • CarbonNeutral product certification 	Add CN suffix.

Specification Information	
Style Number	436AIRSTOOL

Series 2 Coat Hanger



Tip: Headrest and coat hanger can not be attached to a Steelcase Series 2 chair simultaneously.

Tip: Stand alone add on accessories are not available with CarbonNeutral product certification.

Standard Includes		Required to Specify
<ul style="list-style-type: none"> ▶ See <i>Seating Specification Guide</i> for product details. 	<ul style="list-style-type: none"> • Coat hanger color scheme: black 	<ol style="list-style-type: none"> 1 Style number 2 Coat hanger color scheme (see below under Required Selections)

Required Selections	Required to Specify
Coat Hanger Color Scheme <ul style="list-style-type: none"> • Black • Sterling dark 	<ul style="list-style-type: none"> Specify with <i>black</i>. Specify with <i>sterling dark</i>.

Specification Information

• **Style Number**

436COATHANGER

Series 2 Headrest



Tip: Headrest and coat hanger can not be attached to a Steelcase Series 2 chair simultaneously.

Tip: Stand alone add on accessories are not available with CarbonNeutral product certification.

Standard Includes		Required to Specify
<ul style="list-style-type: none"> ▶ See <i>Seating Specification Guide</i> for product details. 	<ul style="list-style-type: none"> • Headrest: fabric price group 1 	<ol style="list-style-type: none"> 1 Style number 2 Headrest frame color scheme (see below under Required Selections) 3 Fabric color number for headrest 4 Options, if selected <ul style="list-style-type: none"> ▶ See <i>Surface Materials</i>, page 480.

Required Selections	Required to Specify
Headrest Frame Color Scheme <ul style="list-style-type: none"> • Black • Sterling dark 	<ul style="list-style-type: none"> Specify with <i>black</i>. Specify with <i>sterling dark</i>.

Options	Required to Specify
Surface Materials Upholstery <ul style="list-style-type: none"> • 3D Microknit • Fabric price group 1 • Fabric price group 2 • Fabric price group 3 • Fabric price group 5 • Fabric price group 6 	<ul style="list-style-type: none"> Specify fabric color number. Specify fabric color number. Specify fabric color number. Specify fabric color number. Specify fabric color number.

Specification Information

• **Style Number**

436HEADREST

Steelcase Series 1 Work Chair

3D Microknit Back with Standard Upholstery on Seat



Standard Includes	Required to Specify
<ul style="list-style-type: none"> ▶ See <i>Seating Specification Guide</i> for product details. • 5" pneumatic seat-height adjustment (16½"–21½") • Frame: plastic • Base: paint or plastic • 2¼" seat depth adjustment • Pill height-, width-, pivot-, and depth-adjustable arms • Adjustable lumbar • Back: 3D Microknit on back • Standard upholstery design on seat: fabric price group 1 • 2½"-diameter, hard-composition, dual-wheel casters: black only 	<ol style="list-style-type: none"> 1 Style number 2 Frame (see below under Required Selections) 3 3D Microknit color number for back 4 Plastic color number for outer back, if contrasting outer back is selected 5 Fabric color number for upholstery on seat 6 Plastic color number for base: 6205 Black (black and seagull frame) 7243 Seagull (seagull frame only) 7 Options, if selected (see below) <p>▶ See <i>Surface Materials</i>, page 480.</p>

Tip: When ordering seagull frame the arms are 6059 Sterling Dark Solid. When ordering black frame, arms are black.

Required Selections	Required to Specify
Frame <ul style="list-style-type: none"> • Black color scheme • Seagull color scheme 	Specify with <i>6205 Black</i> . Specify with <i>6053 Seagull</i> .

Options	Required to Specify
Surface Materials <ul style="list-style-type: none"> • Fabric price group 1 • Fabric price group 2 • Fabric price group 3 • Fabric price group 5 • Fabric price group 6 	Specify fabric color number. Specify fabric color number. Specify fabric color number. Specify fabric color number. Specify fabric color number.

Back color scheme <ul style="list-style-type: none"> • Contrasting outer back 	Specify with <i>contrasting outer back</i> and select plastic color number.
---	---

Arms <ul style="list-style-type: none"> • Height-only adjustable • Armless 	Specify with <i>height-only adjustable</i> . Specify <i>without arms</i> .
---	---

Base <ul style="list-style-type: none"> • Black • Polished aluminum base 	Specify with <i>black base</i> . Specify with <i>aluminum base</i> .
---	---

Headrest <ul style="list-style-type: none"> • Headrest 	Specify with <i>headrest</i> .
--	--------------------------------

Coat Hanger <ul style="list-style-type: none"> • Coat hanger 	Specify with <i>coat hanger</i> .
--	-----------------------------------

Lumbar <ul style="list-style-type: none"> • Adjustable lumbar • Fixed lumbar 	Specify with <i>adjustable lumbar</i> . Specify with <i>fixed lumbar</i> .
---	---

Seat Height <ul style="list-style-type: none"> • 3" short-range pneumatic seat-height adjustment • 5" tall-range pneumatic seat-height adjustment 	Specify with <i>short-range pneumatic seat-height adjustment</i> . Specify with <i>tall-range pneumatic seat-height adjustment</i> .
--	---

Casters <ul style="list-style-type: none"> • Soft, dual-wheel roll-control casters for use on hard floors 	Specify with <i>soft roll-control casters</i> .
---	---

Glides <ul style="list-style-type: none"> • Plastic glides 	Specify with <i>glides</i> .
--	------------------------------

CarbonNeutral Product <ul style="list-style-type: none"> • CarbonNeutral product certification 	Add CN suffix.
--	-----------------------

Specification Information

Style Number . . 435A00 . .
--

Tip: Additional 3D Microknit colors are available when contrasting outer back is selected.

Tip: Base finish matches frame finish, unless seagull frame is selected, then black base is also available.

Tip: Order black base on seagull frame for lowest maintenance.

Tip: A headrest and a coat hanger cannot be attached on a Steelcase Series 1 chair simultaneously.

Tip: When glides are specified, chairs will ship with casters installed and glides provided to install after delivery.

Steelcase Series 1 Stool

3D Microknit with Standard Upholstery on Seat

Steelcase Series 1 Stool



Tip: When ordering seagull frame the arms are 6059 Sterling Dark Solid. When ordering black frame, arms are black.

Tip: 3D Microknit, lumbar, and back flexors colors match unless contrasting outer back is selected.

Tip: Additional 3D Microknit colors are available when contrasting outer back is selected.

Tip: Base finish matches frame finish, unless seagull frame is selected, then black base is also available.

Tip: Order black base on seagull frame for lowest maintenance.

Tip: When glides are specified, stools will ship with casters installed and glides provided to install after delivery.

Tip: Stool ring is always black for lower cleaning maintenance, even on the seagull frame.

Tip: A headrest and a coat hanger cannot be attached on a Steelcase Series 1 chair simultaneously.

Tip: When glides are specified, chairs will ship with casters installed and glides provided to install after delivery.

Standard Includes	Required to Specify
<ul style="list-style-type: none"> ▶ See <i>Seating Specification Guide</i> for product details. • 7¾" pneumatic seat-height adjustment (23"–30¾") • Frame: plastic • Base: plastic • 2¼" seat depth adjustment • Pill height-, width-, pivot-, and depth-adjustable arms • Column and adjustable foot ring: black • Adjustable lumbar • Back: 3D Microknit • Standard upholstery design on seat: fabric price group 1 • 2½"-diameter, hard-composition, dual-wheel casters: black only 	<ol style="list-style-type: none"> 1 Style number 2 Frame (see below under Required Selections) 3 3D Microknit color number for back 4 Plastic color number for outer back, if contrasting outer back is selected 5 Fabric color number for upholstery on seat 6 Plastic color number for base: 6053 Seagull (seagull frame only) 6205 Black (black and seagull frame) 7 Options, if selected (see below) <p>▶ See <i>Surface Materials</i>, page 480.</p>

Required Selections	Required to Specify
Frame <ul style="list-style-type: none"> • Black color scheme • Seagull color scheme 	Specify with 6205 Black. Specify with 6053 Seagull.

Options	Required to Specify
Surface Materials <p>Upholstery on seat</p> <ul style="list-style-type: none"> • Fabric price group 1 • Fabric price group 2 • Fabric price group 3 • Fabric price group 5 • Fabric price group 6 <p>Back color scheme</p> <ul style="list-style-type: none"> • Contrasting outer back 	Specify fabric color number. Specify fabric color number. Specify fabric color number. Specify fabric color number. Specify fabric color number. Specify with contrasting outer back and select plastic color number.
Arms <ul style="list-style-type: none"> • Height-only adjustable • Armless 	Specify with height-only adjustable. Specify without arms.
Base <ul style="list-style-type: none"> • Plastic base • Polished aluminum base 	Specify plastic color number. Specify with aluminum base.
Headrest <ul style="list-style-type: none"> • Headrest 	Specify with headrest.
Coat Hanger <ul style="list-style-type: none"> • Coat hanger 	Specify with coat hanger.
Lumbar <ul style="list-style-type: none"> • Adjustable lumbar • Fixed lumbar 	Specify with adjustable lumbar. Specify with fixed lumbar.
Casters <ul style="list-style-type: none"> • Soft, dual-wheel roll-control casters for use on hard floors 	Specify with soft roll-control casters.
Glides <ul style="list-style-type: none"> • Plastic glides 	Specify with glides.
CarbonNeutral Product <ul style="list-style-type: none"> • CarbonNeutral product certification 	Add CN suffix.

Specification Information

• **Style Number**
 :
 :

435B00
 :

Work Chairs

Steelcase Series 1 Accessories

Steelcase Series 1 Headrest

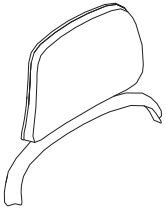

Tip: A headrest and a coat hanger cannot be attached on a Steelcase Series 1 chair simultaneously.

Tip: Stand alone add on accessories are not available with CarbonNeutral product certification.

Standard Includes		Required to Specify
<ul style="list-style-type: none"> ▶ See <i>Seating Specification Guide</i> for product details. 	<ul style="list-style-type: none"> • Headrest frame: plastic • Headrest: 3D Microknit • 3" adjustment range 	<ul style="list-style-type: none"> 1 Style number 2 Plastic color number for frame: <ul style="list-style-type: none"> 6053 Seagull 6205 Black 3 3D Microknit color number for headrest ▶ See <i>Surface Materials</i>, page 480.

Specification Information

• **Style Number**

435HEADREST

Steelcase Series 1 Coat Hanger

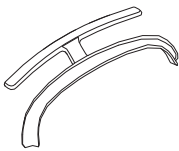

Tip: A headrest and a coat hanger cannot be attached on a Steelcase Series 1 chair simultaneously.

Tip: Stand alone add on accessories are not available with CarbonNeutral product certification.

Standard Includes		Required to Specify
<ul style="list-style-type: none"> ▶ See <i>Seating Specification Guide</i> for product details. 	<ul style="list-style-type: none"> • Coat hanger: plastic 	<ul style="list-style-type: none"> 1 Style number 2 Plastic color number for coat hanger: <ul style="list-style-type: none"> 6053 Seagull 6205 Black

Specification Information

• **Style Number**

435COATHANGER

SILQ 418 Series Collaborative Chair

SILQ 418 Series
Collaborative Chair



Standard Includes		Required to Specify
<ul style="list-style-type: none"> ▶ See <i>Seating Specification Guide</i> for product details. 	<ul style="list-style-type: none"> • 4$\frac{5}{8}$" pneumatic seat-height adjustment (16$\frac{1}{4}$" – 20$\frac{7}{8}$") • Fixed arms: textured paint • Upper back shell and arm caps: plastic • Lower back shell: textured paint • Five-star base: plastic or paint • Standard upholstery design on seat: fabric price group 1 • 2$\frac{1}{2}$"-diameter, hard-composition, dual-wheel casters: black 	<ol style="list-style-type: none"> 1 Style number 2 Fabric color number for upholstery on seat 3 Plastic color number for upper back shell and arm caps 4 Paint color number for lower back shell 5 Paint color number for arms 6 Plastic or paint color number for base 7 Options, if selected (see below) <ul style="list-style-type: none"> ▶ See <i>Surface Materials</i>, page 480.

Tip: Fabric on the SILQ 418 Series will only be applied in the warp vertical/down roll direction.

Tip: Lower back shell and other component finishes have limited selections based on the upper back shell finish selection.

Tip: Armless models cannot be modified to have arms after purchase. Conversely, chairs ordered with arms cannot be removed in the field after purchase.

Options		Required to Specify
Surface Materials	Upholstery on seat	Specify fabric color number. Specify fabric color number.
	<ul style="list-style-type: none"> • Fabric price group 1 • Fabric price group 2 	
Upper Back Shell	<ul style="list-style-type: none"> • 6053 Seagull • 6249 Platinum Solid • 6527 Merle 	Specify with 6053 Seagull. Specify with 6249 Platinum Solid. Specify with 6527 Merle.
Lower Back Shell	<ul style="list-style-type: none"> • 4144 Black Gloss • 7360 Merle 	Specify with 4144 Black Gloss. Specify with 7360 Merle.
Arms	<ul style="list-style-type: none"> • Armless • Polished aluminum 	Specify without arms. Specify with polished aluminum.
Base	<ul style="list-style-type: none"> • Polished aluminum 	Specify with polished aluminum.
Casters	<ul style="list-style-type: none"> • Soft, dark grey treaded, dual-wheel roll-control casters for use on hard floors • Hard, black interior/black treaded hubless casters for use on soft floors • Soft, black interior/dark grey treaded roll-control hubless casters for use on hard floors 	Specify with soft casters. Specify with hard, hubless casters. Specify with soft, hubless casters.
Glides	<ul style="list-style-type: none"> • Glides 	Specify with glides.

Specification Information	
Style Number	
418A000	

Collaboration Seating

SILQ 418 Series Collaborative Stool

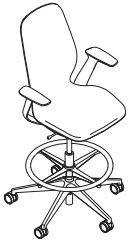

Tip: Fabric on the SILQ 418 Series will only be applied in the warp vertical/down roll direction.

Tip: Lower back shell and other component finishes have limited selections based on the upper back shell finish selection.

▶ See color scheme matrix, in the Seating Specification Guide.

Tip: Armless models cannot be modified to have arms after purchase. Conversely, chairs ordered with arms cannot be removed in the field after purchase.

Standard Includes		Required to Specify
▶ See <i>Seating Specification Guide</i> for product details.	<ul style="list-style-type: none"> 8" pneumatic seat-height adjustment (22⁷/₈" – 30⁷/₈") Fixed arms: textured paint Upper back shell and arm caps: plastic Lower back shell: textured paint Five-star base: plastic or paint Standard upholstery design on seat: fabric price group 1 Adjustable foot ring: plastic color 2"-diameter, hard-composition, dual-wheel casters: black 	<ol style="list-style-type: none"> Style number Fabric color number for upholstery on seat Plastic color number for upper back shell and arm caps Paint color number for lower back shell Paint color number for arms Plastic or paint color number for base Plastic color number for foot ring Options, if selected (see below) <p>▶ See <i>Surface Materials</i>, page 480.</p>

Options		Required to Specify
Surface Materials	Upholstery on seat <ul style="list-style-type: none"> Fabric price group 1 Fabric price group 2 	Specify fabric color number. Specify fabric color number.
Upper Back Shell	<ul style="list-style-type: none"> 6053 Seagull 6249 Platinum Solid 6527 Merle 	Specify with 6053 Seagull. Specify with 6249 Platinum Solid. Specify with 6527 Merle.
Lower Back Shell	<ul style="list-style-type: none"> 4144 Black Gloss 7360 Merle 	Specify with 4144 Black Gloss. Specify with 7360 Merle.
Arms	<ul style="list-style-type: none"> Armless Polished aluminum 	Specify without arms. Specify with polished aluminum.
Base	<ul style="list-style-type: none"> Polished aluminum 	Specify with polished aluminum.
Casters	<ul style="list-style-type: none"> Soft, dark grey treaded, dual-wheel roll-control casters for use on hard floors Hard, black interior/black treaded hubless casters for use on soft floors Soft, black interior/dark grey treaded roll-control hubless casters for use on hard floors 	Specify with soft casters. Specify with hard, hubless casters. Specify with soft, hubless casters.
Glides	<ul style="list-style-type: none"> Glides 	Specify with glides.

Specification Information	
Style Number	
418B000	

QiVi 428 Series Collaborative Chair

QiVi 428 Series
Collaborative Chair



Tip: Frame and arm finish will default to match base finish selection.

	Standard Includes	Required to Specify
▶ See <i>Seating Specification Guide</i> for product details.	<ul style="list-style-type: none"> 4½" pneumatic seat-height adjustment (17½" to 22") Arms, if selected: 6205 black plastic to match base Seat shell, outer back, and soft touch arm caps: plastic Five-star base: 6205 black plastic QiVi Net upholstery on back 15° pivoting backrest Standard upholstery design on seat: fabric price group 1 1" gliding seat 2½"-diameter, hard-composition, dual-wheel casters: black 	<ol style="list-style-type: none"> Style number Plastic color number for base Plastic color number for seat shell, outer back shell, and arm caps, if selected QiVi Net color number for upholstery on back Fabric color number for upholstery on seat Options, if selected (see below) <p>▶ See <i>Surface Materials</i>, page 480.</p>

	Options	Required to Specify
Surface Materials	Upholstery on seat <ul style="list-style-type: none"> Fabric price group 1 Fabric price group 2 Fabric price group 3 Fabric price group 5 Fabric price group 6 Sewn upholstery Steelcase vinyl 	Specify fabric color number. Specify fabric color number. Specify fabric color number. Specify fabric color number. Specify fabric color number. Add S suffix. Add S suffix and specify vinyl color number.
Base	<ul style="list-style-type: none"> Arctic white Platinum metallic 	Specify <i>with 6009 Arctic White</i> . Specify <i>with 4799 Platinum Metallic</i> .
Arms	<ul style="list-style-type: none"> Armless 	Specify <i>without arms</i> .
Gliding Seat	<ul style="list-style-type: none"> Fixed seat 	Specify <i>with fixed seat</i> .
Casters	<ul style="list-style-type: none"> Soft, dark grey treaded, dual-wheel roll-control casters for use on hard floors 	Specify <i>with soft roll-control casters</i> .

Specification Information

• **Style Number**

428510

Collaboration Seating

QiVi 428 Series Collaborative Stool

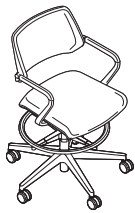

Tip: Frame and arm finish will default to match base finish selection.

Standard Includes		Required to Specify
<ul style="list-style-type: none"> ▶ See <i>Seating Specification Guide</i> for product details. 	<ul style="list-style-type: none"> • 8¼" pneumatic seat-height adjustment (22" to 30¼") • Arms, if selected: 6205 black plastic to match base • Seat shell, outer back, and soft touch arm caps: plastic • Five-star base: 6205 black plastic • QiVi Net upholstery on back • 15° pivoting backrest • Standard upholstery design on seat: fabric price group 1 • 1" gliding seat • Adjustable foot ring: plastic color • 2"-diameter, hard-composition, dual-wheel casters: black 	<ol style="list-style-type: none"> 1 Style number 2 Plastic color number for base and foot ring 3 Plastic color number for seat shell, outer back shell, and arm caps, if selected 4 QiVi Net color number for upholstery on back 5 Fabric color number for upholstery on seat 6 Options, if selected (see below) <ul style="list-style-type: none"> ▶ See <i>Surface Materials</i>, page 480.

Options		Required to Specify
Surface Materials	Upholstery on seat <ul style="list-style-type: none"> • Fabric price group 1 • Fabric price group 2 • Fabric price group 3 • Fabric price group 5 • Fabric price group 6 • Sewn upholstery • Steelcase vinyl 	Specify fabric color number. Specify fabric color number. Specify fabric color number. Specify fabric color number. Add S suffix. Add S suffix and specify vinyl color number.
Base	<ul style="list-style-type: none"> • Arctic white • Platinum metallic 	Specify <i>with 6009 Arctic White</i> . Specify <i>with 4799 Platinum Metallic</i> .
Arms	<ul style="list-style-type: none"> • Armless 	Specify <i>without arms</i> .
Gliding Seat	<ul style="list-style-type: none"> • Fixed seat 	Specify <i>with fixed seat</i> .
Casters	<ul style="list-style-type: none"> • Soft, dark grey treaded, dual-wheel roll-control casters for use on hard floors 	Specify <i>with soft roll-control casters</i> .

Specification Information	
Style Number	428710

QiVi 428 Series Sled-Base Multi-Use Chairs

QiVi 428 Series Sled-Base
Multi-Use Chairs

	Standard Includes	Required to Specify
▶ See <i>Seating Specification Guide</i> for product details.	<ul style="list-style-type: none"> • Frame: 6205 black plastic to match base • Base, seat shell, outer back, and soft touch arm caps: plastic • QiVi Net upholstery on back • 15° pivoting backrest • Standard upholstery design on seat: fabric price group 1 • 1" gliding seat 	<ol style="list-style-type: none"> 1 Style number 2 Plastic color number for base 3 Plastic color number for, seat shell, outer back shell, and arm caps, if selected 4 QiVi Net color number for upholstery on back 5 Fabric color number for upholstery on seat 6 Options, if selected (see below) <p>▶ See <i>Surface Materials</i>, page 480.</p>

	Options	Required to Specify
Surface Materials	Upholstery on seat <ul style="list-style-type: none"> • Fabric price group 1 • Fabric price group 2 • Fabric price group 3 • Fabric price group 5 • Fabric price group 6 	Specify fabric color number. Specify fabric color number. Specify fabric color number. Specify fabric color number.
Base	<ul style="list-style-type: none"> • Arctic white • Platinum metallic 	Specify with 6009 Arctic White. Specify with 4799 Platinum Metallic.
Gliding Seat	<ul style="list-style-type: none"> • Fixed seat 	Specify with fixed seat.
Glides	<ul style="list-style-type: none"> • Hard glides for use on carpeted floors • Soft glides for use on non-carpeted floors 	Specify with hard glides. Specify with soft glides.

Tip: Frame and arm finish will default to match base finish selection.

Collaboration
Seating

Specification Information

• **Style Number**
:

Sled-Base

428310
:

Stacking Sled-Base

428910
:

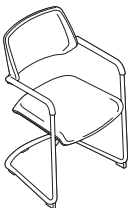
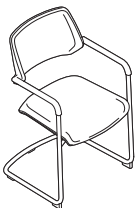



cobi 434 Series Collaborative Chairs

Standard Includes		Required to Specify
<ul style="list-style-type: none"> ▶ See <i>Seating Specification Guide</i> for product details. 	<ul style="list-style-type: none"> • Weight-activated mechanism • 5" pneumatic seat-height adjustment • Fixed arms, if selected: plastic to match outer back • Back upholstery: Connect 3D • Seat upholstery: Cogent: Connect • Frame, outer back, and five-star base: black • 2½"-diameter, hard composition, dual-wheel casters: black plastic 	<ol style="list-style-type: none"> 1 Style number 2 Plastic color number for outer back 3 Connect 3D color number for back 4 Cogent: Connect color number for upholstery on seat 5 Options, if selected (see below) <ul style="list-style-type: none"> ▶ See <i>Surface Materials</i>, page 480.

*Tip: All seat upholstery except standard Cogent: Connect requires a sewn application. Specify with an **S** suffix.*

Options		Required to Specify
Surface Materials	Upholstery <ul style="list-style-type: none"> • Fabric price group 1 • Fabric price group 2 • Fabric price group 3 • Fabric price group 5 • Fabric price group 6 • Sewn upholstery • Steelcase vinyl 	Add S suffix and specify fabric color number. Add S suffix and specify fabric color number. Add S suffix and specify fabric color number. Add S suffix and specify fabric color number. Add S suffix and specify fabric color number. Add S suffix and specify fabric color number. Add S suffix and specify fabric color number.
	Outer back <ul style="list-style-type: none"> • Arctic white • Platinum solid • Near black 	Specify with 6009 Arctic White. Specify with 6249 Platinum Solid. Specify with 6295 Near Black.
Casters	<ul style="list-style-type: none"> • Soft, dark grey treaded, dual-wheel roll-control casters for use on hard floors 	Specify with soft roll-control casters.
Glides	<ul style="list-style-type: none"> • Glides: black plastic 	Specify with glides.

Specification Information	
	
Arms with Soft Arm Caps	Without Arms
• Style Number	• Style Number
434111	434110

Standard Includes		Required to Specify
<ul style="list-style-type: none"> ▶ See <i>Seating Specification Guide</i> for product details. 	<ul style="list-style-type: none"> • Weight-activated mechanism • 10" pneumatic seat-height adjustment • Fixed arms, if selected: plastic to match outer back • Adjustable foot ring: black • Back upholstery: Connect 3D • Seat upholstery: Cogent: Connect • Frame, outer back, and five-star base: black • 2½"-diameter, hard composition, dual-wheel casters: black plastic 	<ol style="list-style-type: none"> 1 Style number 2 Plastic color number for outer back 3 Connect 3D color number for back 4 Cogent: Connect color number for upholstery on seat 5 Options, if selected (see below) <ul style="list-style-type: none"> ▶ See <i>Surface Materials</i>, page 480.

*Tip: All seat upholstery except standard Cogent: Connect requires a sewn application. Specify with an **S** suffix.*

Options	Required to Specify
<p>Surface Materials</p> <ul style="list-style-type: none"> • Fabric price group 1 • Fabric price group 2 • Fabric price group 3 • Fabric price group 5 • Fabric price group 6 • Sewn upholstery • Steelcase vinyl 	<p>Upholstery</p> <ul style="list-style-type: none"> • Add S suffix and specify fabric color number. • Add S suffix and specify fabric color number. • Add S suffix and specify fabric color number. • Add S suffix and specify fabric color number. • Add S suffix and specify fabric color number. • Add S suffix and specify fabric color number. • Add S suffix and specify fabric color number.
<p>Outer back</p> <ul style="list-style-type: none"> • Arctic white • Platinum solid • Near black 	<ul style="list-style-type: none"> • Specify with 6009 Arctic White. • Specify with 6249 Platinum Solid. • Specify with 6295 Near Black.
<p>Casters</p> <ul style="list-style-type: none"> • Soft, dark grey treaded, dual-wheel roll-control casters for use on hard floors 	<ul style="list-style-type: none"> • Specify with soft roll-control casters.
<p>Glides</p> <ul style="list-style-type: none"> • Glides: black plastic 	<ul style="list-style-type: none"> • Specify with glides.

Specification Information



Arms with Soft Arm Caps

• Style Number

434711



Without Arms

• Style Number

434710

Node 480 Series Collaborative Chairs

With Tripod Base

Standard Includes		Required to Specify
<ul style="list-style-type: none"> ▶ See <i>Seating Specification Guide</i> for product details. 	<ul style="list-style-type: none"> • Seat shell: plastic price group 1 • Tripod base: plastic • Storage tray: sterling dark solid • Metal components: 0835 Black paint • Swivel seat • Worksurface, if selected: plastic • Hard casters 	<ul style="list-style-type: none"> 1 Style number 2 Plastic color number for seat shell 3 Plastic color number for tripod base 4 Paint color number for metal components 5 Plastic color number for personal worksurface, if selected 6 Options, if selected (see below) ▶ See <i>Surface Materials</i>, page 480.

Options		Required to Specify
Surface Materials	Platinum metallic metal components <ul style="list-style-type: none"> • On 480110 • On 480120 	Specify with 4799 Platinum Metallic. Specify with 4799 Platinum Metallic.
Tablet Stand	<ul style="list-style-type: none"> • On 480120 	Specify with tablet stand.
Casters	<ul style="list-style-type: none"> • Soft casters 	Specify with soft casters.

Specification Information

• **Style Number**

Without Personal Worksurface

480110

With Personal Worksurface

480120

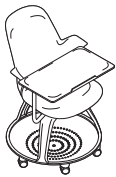

Node 480 Series Collaborative Chairs

With Five-Star Base

Node 480 Series
Collaborative Chairs

Standard Includes		Required to Specify
<ul style="list-style-type: none"> ▶ See <i>Seating Specification Guide</i> for product details. 	<ul style="list-style-type: none"> • Seat shell: plastic price group 1 • Five-star base: plastic • Metal components: 0835 Black paint • Swivel seat • 5¼" pneumatic seat-height adjustment • Hard casters 	<ul style="list-style-type: none"> 1 Style number 2 Plastic color number for seat shell 3 Plastic color number for five-star base 4 Options, if selected (see below) ▶ See <i>Surface Materials</i>, page 480.

Tip: Metal components will match plastic color for base.

Options		Required to Specify
Base	<ul style="list-style-type: none"> • Platinum on 480130 • Platinum on 480150 	<ul style="list-style-type: none"> Specify with <i>6249 Platinum</i>. Specify with <i>6249 Platinum</i>.
Tablet Stand	<ul style="list-style-type: none"> • On 480150 	<ul style="list-style-type: none"> Specify with <i>tablet stand</i>.
Casters	<ul style="list-style-type: none"> • Soft, dark grey treaded, dual-wheel roll-control casters for use on hard floors 	<ul style="list-style-type: none"> Specify with <i>soft roll-control casters</i>.

Specification Information

• **Style Number**
:
:

Without Personal Worksurface

480130
:
:

With Personal Worksurface

480150
:
:



Collaboration
Seating

Node 480 Series Mid-Back Collaborative Chairs

With Tripod Base

Standard Includes		Required to Specify
<ul style="list-style-type: none"> ▶ See <i>Seating Specification Guide</i> for product details. 	<ul style="list-style-type: none"> • Seat shell: plastic price group 1 • Tripod base: plastic • Storage tray: sterling dark solid • Metal components: 0835 Black paint • Swivel seat • Worksurface, if selected: plastic • Hard casters 	<ul style="list-style-type: none"> 1 Style number 2 Plastic color number for seat shell 3 Plastic color number for tripod base 4 Paint color number for metal components 5 Plastic color number for personal work-surface, if selected 6 Options, if selected (see below) ▶ See <i>Surface Materials</i>, page 480.

Options		Required to Specify
Surface Materials	Platinum metallic metal components <ul style="list-style-type: none"> • On 480210 • On 480220 	Specify with 4799 <i>Platinum Metallic</i> . Specify with 4799 <i>Platinum Metallic</i> .
Tablet Stand	<ul style="list-style-type: none"> • On 480220 	Specify with <i>tablet stand</i> .
Casters	<ul style="list-style-type: none"> • Soft, dark grey treaded, dual-wheel roll-control casters for use on hard floors 	Specify with <i>soft roll-control casters</i> .

Specification Information

• **Style Number**

Without Personal Worksurface

480210

:

With Personal Worksurface

480220

:



Node 480 Series Mid-Back Collaborative Chairs

With Five-Star Base

Node 480 Series
Mid-Back
Collaborative Chairs

Standard Includes		Required to Specify
▶ See <i>Seating Specification Guide</i> for product details.	<ul style="list-style-type: none"> • Seat shell: plastic price group 1 • Five-star base: plastic • Metal components: 0835 Black paint • Swivel seat • 5¼" pneumatic seat-height adjustment • Hard casters 	<ul style="list-style-type: none"> 1 Style number 2 Plastic color number for seat shell 3 Plastic color number for five-star base 4 Options, if selected (see below) <p>▶ See <i>Surface Materials</i>, page 480.</p>

Tip: Metal components will match plastic color for base.

Options		Required to Specify
Base	<ul style="list-style-type: none"> • Platinum on 480230 • Platinum on 480250 	Specify with <i>6249 Platinum</i> . Specify with <i>6249 Platinum</i> .
Tablet Stand	<ul style="list-style-type: none"> • On 480250 	Specify with <i>tablet stand</i> .
Casters	<ul style="list-style-type: none"> • Soft, dark grey treaded, dual-wheel roll-control casters for use on hard floors 	Specify with <i>soft roll-control casters</i> .

Specification Information

• **Style Number**
:
:

Without Personal Worksurface

480230
:
:

With Personal Worksurface

480250
:
:



Collaboration
Seating

Node 480 Series Collaborative Stool

With Five-Star Base

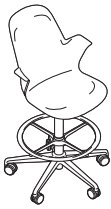

Tip: Metal components will match plastic color for base.

Standard Includes		Required to Specify
<ul style="list-style-type: none"> ▶ See <i>Seating Specification Guide</i> for product details. 	<ul style="list-style-type: none"> • Seat shell: plastic price group 1 • Five-star base: plastic • Metal components: 0835 Black paint • Swivel seat • 8½" pneumatic seat-height adjustment • Hard casters 	<ul style="list-style-type: none"> 1 Style number 2 Plastic color number for seat shell 3 Plastic color number for five-star base 4 Options, if selected (see below) ▶ See <i>Surface Materials</i>, page 480.

Options		Required to Specify
Seat-Height	<ul style="list-style-type: none"> • 7½" pneumatic seat-height adjustment 	Specify with 7" pneumatic seat-height adjustment.
Base	<ul style="list-style-type: none"> • Platinum 	Specify with 6249 Platinum.
Casters	<ul style="list-style-type: none"> • Soft, dark grey treaded, dual-wheel roll-control casters for use on hard floors 	Specify with soft roll-control casters.

Specification Information
<ul style="list-style-type: none"> • Style Number
480140

Node 480 Series Mid-Back Collaborative Stool

With Five-Star Base

Node 480 Series
Mid-Back
Collaborative Stool

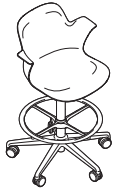

Tip: Metal components will match plastic color for base.

Standard Includes		Required to Specify
<ul style="list-style-type: none"> ▶ See <i>Seating Specification Guide</i> for product details. 	<ul style="list-style-type: none"> • Seat shell: plastic price group 1 • Five-star base: plastic • Metal components: 0835 Black paint • Swivel seat • 8½" pneumatic seat-height adjustment • Hard casters 	<ul style="list-style-type: none"> 1 Style number 2 Plastic color number for seat shell 3 Plastic color number for five-star base 4 Options, if selected (see below) ▶ See <i>Surface Materials</i>, page 480.

Options		Required to Specify
Seat-Height	<ul style="list-style-type: none"> • 7½" pneumatic seat-height adjustment 	Specify with 7" pneumatic seat-height adjustment.
Base	<ul style="list-style-type: none"> • Platinum 	Specify with 6249 Platinum.
Casters	<ul style="list-style-type: none"> • Soft, dark grey treaded, dual-wheel roll-control casters for use on hard floors 	Specify with soft roll-control casters.

Specification Information	
Style Number	
480240	

Collaboration Seating

Collaboration Guest Seating



Standard Includes		Required to Specify
<ul style="list-style-type: none"> ▶ See <i>Seating Specification Guide</i> for product details. 	<ul style="list-style-type: none"> • Frame: European Beech • Upholstery on seat and back: fabric price group 1 • Glides: stainless steel only 	<ul style="list-style-type: none"> 1 Style number 2 Fabric color number for upholstery 3 Wood color number for frame 4 Options, if selected (see below) ▶ See <i>Surface Materials</i>, page 480.

Options		Required to Specify
Surface Materials <ul style="list-style-type: none"> • Fabric price group 1 • Fabric price group 2 • Fabric price group 3 • Fabric price group 5 • Fabric price group 6 	Upholstery on seat and back	<ul style="list-style-type: none"> Specify fabric color number. Specify fabric color number. Specify fabric color number. Specify fabric color number. Specify fabric color number.

Specification Information	
	Open <input type="checkbox"/>
Description	Style Number
Wood arms	120
:	:

Bob Lounge Chairs by Walter Knoll

DESIGN PEARSON LLOYD

Tip: Fabrics will appear loose with comfort wrinkles when upholstered.

Standard Includes	Required to Specify
<ul style="list-style-type: none"> ▶ See <i>Coalesse Seating Specification Guide</i> for product details. 	<ul style="list-style-type: none"> • Base: 8040 Aluminum Matte Polished or group 1 paint • Swivel base for lounge chairs, if selected • Upholstery for chair: fabric or vinyl • Glides
	<ul style="list-style-type: none"> 1 Style number 2 Fabric color number for upholstery 3 Options, if selected (see below) <p>▶ See <i>Surface Materials</i>, page 480.</p>

Options	Required to Specify
Surface Materials <ul style="list-style-type: none"> • Aluminum matte polished • Group 1 paint 	<ul style="list-style-type: none"> Specify with <i>standard swivel</i> and select aluminum matte polished. Specify with <i>standard swivel</i> and select paint color number.

Specification Information

Style Number	Fabric Groups:				
	1	2	3	5	6

Lounge Chair					
216	•	•	•	•	•



Overall: 34¼"D 35"W 31¾"H
 Inside: 21¾"D 20"W 17¼"H
 Seat: 17"H
 Arm: 21¾"H

Lounge Chair with Headrest					
221	•	•	•	•	•



Overall: 34¼"D 35"W 41¼"H
 Inside: 21¾"D 20"W 27½"H
 Seat: 17"H
 Arm: 21¾"H

Ottoman					
221-H	•	•	•	•	•



Overall: 18½"D 19¾"W 15¼"H

Collaboration Seating

Bob Chair by Walter Knoll

DESIGN PEARSON LLOYD

Tip: Fabrics will appear loose with comfort wrinkles when upholstered.

Standard Includes	Required to Specify
<ul style="list-style-type: none"> ▶ See <i>Coalesse Seating Specification Guide</i> for product details. • Swivel base: group 1 paint • Upholstery for chair: fabric or vinyl • Glides 	<ul style="list-style-type: none"> 1 Style number 2 Metal of paint color number for base and arms 3 Fabric color number for upholstery on seat, inner, and outer back 4 Options, if selected (see below) ▶ See <i>Surface Materials</i>, page 480.

Options	Required to Specify
Surface Materials <ul style="list-style-type: none"> • Group 1 paint • Group 2 paint 	<ul style="list-style-type: none"> Specify paint color number. Specify paint color number.

Specification Information

Style Number	Fabric Groups:				
	1	2	3	5	6

Guest Chair

231	•	•	•	•	•
-----	---	---	---	---	---



Overall: 25¼"D 27¼"W 29¾"H
 Inside: 18"D 18"W 12½"H
 Seat: 18½"H
 Arm: 26½"H

Ottoman

221-H	•	•	•	•	•
-------	---	---	---	---	---

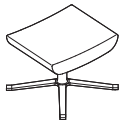

Overall: 18½"D 19¾"W 15¼"H

Bindu Conference Seating

DESIGN BRIAN KANE



Overall: 25"D 25"W 35½"H-40¼"H
Inside: 18¾"D 18½"W-19½"W 21"H
Seat: 16"-20½"H
Arm: 24¼"-29"H

Tip: Fabrics will appear loose with comfort wrinkles when upholstered.

Tip: Craft in upholstery cautions the use of stripes and patterns on Bindu. Please use fabric database when specifying.

Tip: For fabric with a large pattern and a specific pattern location is desired, contact Customer Service.

Standard Includes	Required to Specify
-------------------	---------------------

► See *Coalesse Seating Specification Guide* for product details.

- Bent plywood frame
- Chair: fabric
- Molded polypropylene foam
- Base: 8046 Polished Aluminum
- Dual wheel hard casters, desk and conference
- Back tilt lock

- 1 Style number
 - 2 Fabric color number for upholstery
- See *Surface Materials*, page 480.

Specification Information

Style Number	Fabric Groups:					
	1	2	3	5	6	

Mid-Back Conference Chair

C0300	•	•	•	•	•
-------	---	---	---	---	---

Bindu Chairs

DESIGN BRIAN KANE



Overall: 25"D 24½"W 33¾"H
 Inside: 16¾"D 18½"-19½"W 15"H
 Seat: 17¾"H
 Arm: 26¼"H

Tip: Fabrics will appear loose with comfort wrinkles when upholstered.

Tip: Craft in upholstery cautions the use of stripes and patterns on Bindu. Please use fabric database when specifying.

Tip: For fabric with large pattern and specific pattern location is desired, contact Customer Service.

Standard Includes	Required to Specify
-------------------	---------------------

- | | |
|--|---|
| <ul style="list-style-type: none"> ▶ See <i>Coalesse Seating Specification Guide</i> for product details. | <ul style="list-style-type: none"> • Bent plywood frame • Chair: fabric • Molded polypropylene foam • Frame: 9207 Polished Trivalent Chrome • Glides: black, non-marring |
| | <ul style="list-style-type: none"> 1 Style number 2 Fabric color number for upholstery ▶ See <i>Surface Materials</i> , page 480. |

Specification Information					
Style Number	Fabric Groups:				
	1	2	3	5	6

Low-Back Chair

CO200G	•	•	•	•	•
--------	---	---	---	---	---

Enea Lottus Chairs Armless

DESIGN LIEVORE ALTHERR MOLINA

Tip: Lottus chair with no insert stacks 10 high on floor. Lottus chair with polypropylene or upholstered insert stacks four high on floor. Lottus chair stacks six high with dolly.

Standard Includes	Required to Specify
<ul style="list-style-type: none"> ▶ See <i>Coalesse Seating Specification Guide</i> for product details. • Base and frame constructed of painted steel tubing: paint price group 1 • Seat and back: polypropylene • Insert, if selected: polypropylene or upholstery 	<ol style="list-style-type: none"> 1 Style number 2 Plastic color number for seat and back 3 Fabric color number for upholstery insert, if selected 4 Paint color number for base and frame 5 Options, if selected (see below) <p>▶ See <i>Surface Materials</i>, page 480.</p>

Options	Required to Specify
Surface Materials <ul style="list-style-type: none"> • Acrylic backer • Backer for chair with upholstered insert 	Specify with acrylic backer.
Felt Glides <ul style="list-style-type: none"> • Glides 	Specify with felt glides.

Specification Information

Style Number	Armless Chair with No Insert
--------------	-------------------------------------

COEL100	•
---------	---



Overall: 20¾"D 20¾"W 30½"H
 Seat: 18"H
 Seat Depth: 16½"D
 Stacked 10 high:
 24½"D x 19½"W x 44"H
 Dolly in up-right position:
 40"D x 26"W x 46"H
 Dolly in reclined position:
 47"D x 26"W x 44"H

Style Number	Fabric Groups:	1	2	3	5	6
--------------	----------------	---	---	---	---	---

Armless Chair with Upholstered Insert

COEL100UPH	• • • •
------------	---------



Overall: 20¾"D 20¾"W 30½"H
 Seat: 18"H
 Seat Depth: 16½"D

Enea Lottus Sled Stools Sled Base

DESIGN LIEVORE ALTHERR MOLINA

Tip: If base and frame are specified in a white, platinum, or champagne finish, glides will be white. For all other base and frame colors, glides will be black.

Standard Includes	Required to Specify
<ul style="list-style-type: none"> See <i>Colesse Seating Specification Guide</i> for product details. Base and frame constructed of painted steel tubing: paint price group 1 Seat and back: polypropylene Insert, if selected: upholstery 	<ul style="list-style-type: none"> 1 Style number 2 Plastic color number for seat and back 3 Fabric color number for upholstery insert, if selected 4 Paint color number for base and frame 5 Options, if selected (see below) <p>► See <i>Surface Materials</i>, page 480.</p>

Options	Required to Specify
Surface Materials <ul style="list-style-type: none"> Acrylic backer <ul style="list-style-type: none"> Backer for chair with upholstered insert 	Specify with acrylic backer.

Specification Information

Style Number

Sled Base Bar-Height Stool with No Insert

COEL400 •

Style Number	Fabric Groups:				
	1	2	3	5	6

Sled Base Bar-Height Stool with Upholstered Insert

COEL400UPH • • • • •



Overall: 18"D 18¼"W 38½"H
 Seat: 30"H
 Seat Depth: 13⅞"D



Overall: 18"D 18¼"W 38½"H
 Seat: 30"H
 Seat Depth: 13⅞"D

Marien152 Conference Seating

DESIGN COALESSE DESIGN GROUP AND ARIK LEVY

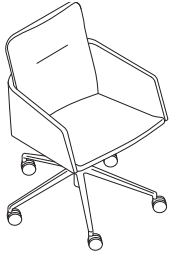

Overall: 24"D x 26"W x 31-36"H
 Inside: 16 1/2"D x 18"W
 Seat: 17" - 22"H

Standard Includes		Required to Specify
<ul style="list-style-type: none"> ▶ See <i>Coalesse Seating Specification Guide</i> for product details. 	<ul style="list-style-type: none"> • Seat, back, and surround: upholstery • Leather strap: coal • Base: 8046 Polished Aluminum or group 1 paint • 5-star base: <ul style="list-style-type: none"> – 5" pneumatic height adjustment, 360° swivel – Black dual wheel casters 	<ol style="list-style-type: none"> 1 Style number 2 Fabric color number for upholstery on seat, surround, and back 3 Metal or paint color number for base 4 Options, if selected (see below) <ul style="list-style-type: none"> ▶ See <i>Surface Materials</i>, page 480.

Options		Required to Specify
Surface Materials	Base	
	<ul style="list-style-type: none"> • Polished aluminium • Group 1 paint • Group 3 paint 	Specify with <i>aluminium matte polished</i> . Specify paint color number. Specify paint color number.
	<ul style="list-style-type: none"> • Backer 	Specify with <i>acrylic backer</i> .
Caster or Glide Type	<ul style="list-style-type: none"> • Hard casters • Soft casters 	Specify with <i>hard casters</i> . Specify with <i>soft casters</i> .
	Pull	<ul style="list-style-type: none"> • With leather pull • Without leather pull

Specification Information						
Style Number	Fabric Groups:					
	1	2	3	5	6	

5-Star Conference Chair

COMARCCCH5 • • • • •

Marien152 Guest Seating Wood Base

DESIGN COALESSE DESIGN GROUP AND ARIK LEVY

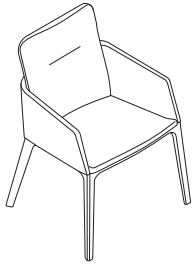

Overall: 23½"D x 25"W x 31½"H
 Inside: 16½"D x 18"W
 Seat: 18½"H

Standard Includes		Required to Specify
<ul style="list-style-type: none"> ▶ See <i>Coalesse Seating Specification Guide</i> for product details. 	<ul style="list-style-type: none"> • Seat, back, and surround: upholstery • Leather strap: coal • Base: group 1 oak stain • Black hard glides 	<ol style="list-style-type: none"> 1 Style number 2 Fabric color number for upholstery on seat, surround, and back 3 Stain color number for base 4 Options, if selected (see below) <ul style="list-style-type: none"> ▶ See <i>Surface Materials</i>, page 480.

Options		Required to Specify
Surface Materials	<ul style="list-style-type: none"> • Backer 	Specify with <i>acrylic backer</i> .
Caster or Glide Type	<ul style="list-style-type: none"> • Hard glides • Soft glides 	Specify with <i>hard glides</i> . Specify with <i>soft glides</i> .
Pull	<ul style="list-style-type: none"> • With leather pull • Without leather pull 	Specify with <i>pull</i> . Specify <i>without pull</i> .

Specification Information					
Style Number	Fabric Groups:				
	1	2	3	5	6
COMARCHWB	•	•	•	•	•

Marien152 Guest Seating Metal Base

DESIGN COALESSE DESIGN GROUP AND ARIK LEVY

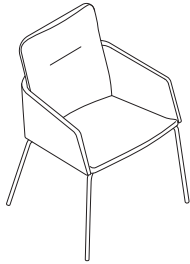

Overall: 24"D x 26"W x 31½"H
 Inside: 16½"D x 18"W
 Seat: 18"H

Standard Includes	Required to Specify
<ul style="list-style-type: none"> ▶ See <i>Coalesse Seating Specification Guide</i> for product details. • Seat, back, and surround: upholstery • Leather strap: coal • Base: group 1 paint • Black hard glides 	<ul style="list-style-type: none"> 1 Style number 2 Fabric color number for upholstery on seat, surround, and back 3 Paint color number for base 4 Options, if selected (see below) ▶ See <i>Surface Materials</i>, page 480.

Options	Required to Specify
Surface Materials <ul style="list-style-type: none"> • Base • Group 1 paint • Group 3 paint 	<ul style="list-style-type: none"> Specify paint color number. Specify paint color number.
<ul style="list-style-type: none"> • Backer 	<ul style="list-style-type: none"> Specify <i>with acrylic backer</i>.
Pull <ul style="list-style-type: none"> • With leather pull • Without leather pull 	<ul style="list-style-type: none"> Specify <i>with pull</i>. Specify <i>without pull</i>.

Specification Information					
Style Number	Fabric Groups:				
	1	2	3	5	6
COMARCHMB	•	•	•	•	•

Massaud Conference Seating

DESIGN COALESSE DESIGN GROUP AND JEAN-MARIE MASSAUD

Tip: For duvet conference chairs, fabrics will appear loose with comfort wrinkles when upholstered.

Tip: Pneumatic height adjustment allows user to change seat height, with the assistance of a pneumatic gas cylinder. Synchro-tilt mechanism has three recline positions and two tension positions.

Tip: Vinyls are not recommended on arm cap upholstery.

Tip: Loop arms can be adjusted out 1" on either side. Requires tools and must be done by a facility manager.

Tip: Easy slide glides are to be used on carpet and soft flooring.

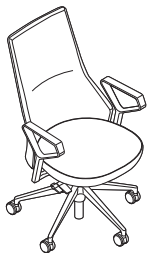

With 5-star base
Overall: 23¾"W x 25"D x 38¼"-43½"H
Inside: 19¼"W x 18"D
Seat: 16¾"-21¾" H
Arm: 24½"-29¾"H

Standard Includes	Required to Specify
<ul style="list-style-type: none"> ▶ See <i>Coalesse Seating Specification Guide</i> for product details. • Base: 8040 Aluminum Matte Polished or group 1 paint • Outer back and inner back: see upholstery understanding • Pneumatic height adjustment and synchro-tilt mechanism • Arms: <ul style="list-style-type: none"> – Mid-back chair, if selected: 8040 Aluminum Matte or group 1 paint • Polished loop arms (without arm caps): <ul style="list-style-type: none"> – Low-back chair, if selected: fully upholstered integrated arms • Base: <ul style="list-style-type: none"> – Chairs with loop arms, if selected: 5-star base with black, dual wheel hard casters 	<ol style="list-style-type: none"> 1 Style number 2 Metal of paint color number for base and arms 3 Fabric color number for upholstery on seat, inner, and outer back 4 Options, if selected (see below) <p>▶ See <i>Surface Materials</i>, page 480.</p>

Options	Required to Specify
Surface Materials <ul style="list-style-type: none"> • Base and arms • Aluminum matte polished • Group 1 paint • Group 2 paint 	Specify with <i>aluminum matte polished</i> . Specify paint color number. Specify paint color number.
Base <ul style="list-style-type: none"> • Chairs with integrated arms • 5-star base 	Specify with <i>5-star base</i> .
Arm Caps <ul style="list-style-type: none"> • Chairs with loop arms • Vinyl is excluded 	Specify with <i>arm caps</i> and select finish.
Caster or Glide Type <ul style="list-style-type: none"> • Chairs with 5-star base • Hard casters • Soft casters 	Specify with <i>hard casters</i> . Specify with <i>soft casters</i> .

Specification Information	
Style Number	Fabric Groups: 1 2 3 5 6

Mid-Back Conference Chair with Loop Arm

COMCCHMBST • • • • •

▶ Specification Information, continued on next page

Massaud Conference Seating

DESIGN COALESSE DESIGN GROUP AND JEAN-MARIE MASSAUD

► Specification Information, continued from previous page

Specification Information

Style Number	Fabric Groups:				
	1	2	3	5	6

Low-Back Conference Chair with Integrated Arm

COMCCHLBSTNT	•	•	•	•	•
--------------	---	---	---	---	---



With 5-star base

Overall: 24³/₄" W x 23" D x 31¹/₂"-36³/₄" H

Inside: 23³/₄" W x 18" D

Seat: 16³/₄"-21³/₄" H

Arm: 24¹/₂"-29³/₄" H

Montara650 Chairs

DESIGN LIEVORE ALTHERR MOLINA



Standard Includes		Required to Specify
<ul style="list-style-type: none"> ▶ See <i>Coesse Seating Specification Guide</i> for product details. 	<ul style="list-style-type: none"> • Seat and back: upholstery, if selected • Shell: wood shell, wood shell with upholstered seat, or ¾ upholstery with wood shell, if selected: <ul style="list-style-type: none"> • group 1 wood veneer • Base: group 1 paint • Glides 	<ol style="list-style-type: none"> 1 Style number 2 Upholstery version (see below under Required Selections) 3 Fabric color number for seat and back, if selected 4 Wood finish on shell, if selected 5 Base type (see below under Required Selections) 6 Paint color number for base 7 Options, if selected (see below) <ul style="list-style-type: none"> ▶ See <i>Surface Materials</i>, page 480.
Required Selections		Required to Specify
Upholstery Version	<ul style="list-style-type: none"> • Wood shell • Wood shell with upholstered seat • Wood shell with ¾ upholstery • Fully upholstered 	<ul style="list-style-type: none"> Specify with <i>wood seat and back</i>. Specify with <i>upholstered seat, wood back</i>. Specify with <i>¾ upholstered</i>. Specify with <i>upholstered seat and back</i>.
Base Type	<ul style="list-style-type: none"> • 4-leg • Sled base 	<ul style="list-style-type: none"> Specify with <i>4-leg</i>. Specify with <i>sled base</i>.
Options		Required to Specify
Surface Materials	<p>Base, armless</p> <ul style="list-style-type: none"> • Group 1 paint • Group 2 paint <hr/> <p>Wood shell</p> <ul style="list-style-type: none"> • Group 1 wood veneer <hr/> <p>Acrylic backer</p> <ul style="list-style-type: none"> • Seat • Seat and back 	<ul style="list-style-type: none"> Specify paint color number. Specify paint color number. <hr/> <ul style="list-style-type: none"> Specify with <i>VP01 Oak Light</i> or <i>VP05 White Oak</i>. <hr/> <ul style="list-style-type: none"> Specify with <i>acrylic backer</i>. Specify with <i>acrylic backer</i>.

Montara650 Chairs

DESIGN LIEVORE ALTHERR MOLINA

Specification Information



4-leg, armless
Overall: 20½"W x 20½"D x 31"H
Seat: 17½"H



Sled base, armless
Overall: 20½"W x 20½"D x 31"H
Seat: 17½"H

Style
Number

Wood Shell Chair

COSFZCH Seat •

Style	Fabric Groups:				
Number	1	2	3	5	6

Wood Shell Chair with Upholstered Seat

COSFZCH Seat • • • • •

Wood Shell Chair with ¾ Upholstery

COSFZCH Seat • • • • •

Back • • • • •

Fully Upholstered Chair

COSFZCH Seat • • • • •

Back • • • • •

Collaboration Seating

Montara650 Stools

DESIGN LIEVORE ALTHERR MOLINA



Stool at bar height
Overall: 18 1/4"W 19 1/2"D 39 1/2"H
Seat: 30"H

Standard Includes	Required to Specify
<ul style="list-style-type: none"> ▶ See <i>Coalesse Seating Specification Guide</i> for product details. • Seat and back upholstery, if selected • Shell: wood shell or wood shell with upholstered seat, if selected: wood veneer group 1 • Sled base: group 1 paint • Bar height • Glides 	<ol style="list-style-type: none"> 1 Style number 2 Application (see below under Required Selections) 3 Upholstery version (see below under Required Selections) 4 Fabric color number for seat and/or back, if selected 5 Wood finish on shell, if selected 6 Paint color number for base 7 Options, if selected (see below) <p>▶ See <i>Surface Materials</i>, page 480.</p>

Required Selections	Required to Specify
Upholstery Version <ul style="list-style-type: none"> • Wood shell • Wood shell with upholstered seat • Fully upholstered 	<p>Specify with <i>wood seat and back</i>. Specify with <i>upholstered seat and wood back</i>. Specify with <i>upholstered seat and back</i>.</p>

Options	Required to Specify
Surface Materials <p>Base</p> <ul style="list-style-type: none"> • Group 1 paint • Group 2 paint <hr/> <p>Shell</p> <ul style="list-style-type: none"> • Group 1 wood veneer <hr/> <p>Acrylic backer</p> <ul style="list-style-type: none"> • Seat • Seat and back 	<p>Specify paint color number. Specify paint color number.</p> <hr/> <p>Specify with <i>VP01 Oak Light</i> or <i>VP05 White Oak</i>.</p> <hr/> <p>Specify with <i>acrylic backer</i>. Specify with <i>acrylic backer</i>.</p>

Specification Information

Style Number

Wood Shell Stool

COSFZST •

Specification Information

Style Number	Fabric Groups:				
	1	2	3	5	6

Wood Shell Stool with Upholstered Seat

COSFZST	Seat	•	•	•	•	•
---------	------	---	---	---	---	---

Fully Upholstered Stool

COSFZST	Seat	•	•	•	•	•
	Back	•	•	•	•	•

Campfire Big Lounge

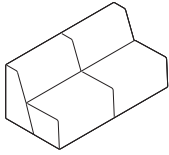

Tip: Campfire big lounges can be ordered as a single or multi-fabric upholstery.

Standard Includes	Required to Specify
<ul style="list-style-type: none"> ▶ See <i>Seating Specification Guide</i> for product details. Fully upholstered armless lounge: fabric price group 1 Foot: black plastic Shipped fully assembled Meets Cal. 117 requirements 	<ul style="list-style-type: none"> 1 Style number 2 Fabric color number for upholstery 3 Options, if selected (see below) ▶ See <i>Surface Materials</i>, page 480.

Options		Required to Specify
Surface Materials	<p>Single upholstery fabric</p> <ul style="list-style-type: none"> Fabric price group 1 Fabric price group 2 Fabric price group 3 Fabric price group 5 Fabric price group 6 <p>Multiple upholstery fabric</p> <ul style="list-style-type: none"> Different fabric on seat and back <p>① Fabric on seat</p> <ul style="list-style-type: none"> Fabric price group 1 Fabric price group 2 Fabric price group 3 Fabric price group 5 Fabric price group 6 <p>② Fabric on back</p> <ul style="list-style-type: none"> Fabric price group 1 Fabric price group 2 Fabric price group 3 Fabric price group 5 Fabric price group 6 	<p>Specify fabric color number.</p> <p>Specify fabric color number.</p> <p>Specify fabric color number.</p> <p>Specify fabric color number.</p> <p>Specify fabric color number.</p> <hr/> <p>Add suffix M to big lounge chair style number and select fabric color number for: 1 Seat, 2 Back</p> <p>Specify fabric color number.</p> <p>Specify fabric color number.</p> <p>Specify fabric color number.</p> <p>Specify fabric color number.</p> <p>Specify fabric color number.</p> <hr/> <p>Specify fabric color number.</p> <p>Specify fabric color number.</p> <p>Specify fabric color number.</p> <p>Specify fabric color number.</p> <p>Specify fabric color number.</p>

Specification Information				
Dimensions			Style Number	
D	W	H		
32"	66"	29"	TS3BC	

Lounge Seating

Campfire Big Lounge—Waterfall

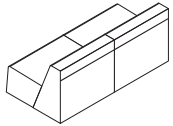
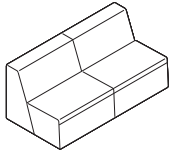

Tip: Waterfall seams are located at the top of the back, the front edge of the seat, 3½" below the front edge seam and 3½" below the top edge seam on the back of the lounge.

Tip: One thread color is used on waterfall lounges with multiple fabrics. The thread color used on the waterfall upholstery will be used on the entire unit.

*Tip: Order ganging brackets **TS3GANGING** to gang units together for more stable applications.*

Standard Includes	Required to Specify
<ul style="list-style-type: none"> ▶ See <i>Seating Specification Guide</i> for product details. • Fully upholstered armless lounge: fabric price group 1 • Foot: black plastic • Shipped fully assembled • Meets Cal. 117 requirements • Multiple upholstery fabric 	<ul style="list-style-type: none"> 1 Style number 2 Fabric color number for upholstery 3 Options, if selected (see below) ▶ See <i>Surface Materials</i>, page 480.

Options	Required to Specify
<p>Surface Materials</p> <p>Single upholstery fabric</p> <ul style="list-style-type: none"> • Fabric price group 1 • Fabric price group 2 • Fabric price group 3 • Fabric price group 5 • Fabric price group 6 <p>Multiple upholstery fabric</p> <p>① Fabric on seat</p> <ul style="list-style-type: none"> • Fabric price group 1 • Fabric price group 2 • Fabric price group 3 • Fabric price group 5 • Fabric price group 6 <p>② Fabric on back</p> <ul style="list-style-type: none"> • Fabric price group 1 • Fabric price group 2 • Fabric price group 3 • Fabric price group 5 • Fabric price group 6 	<ul style="list-style-type: none"> Specify fabric color number. Specify fabric color number. Specify fabric color number. Specify fabric color number. Specify fabric color number. <hr/> <ul style="list-style-type: none"> Specify fabric color number. Specify fabric color number. Specify fabric color number. Specify fabric color number. Specify fabric color number.

Specification Information				
• Dimensions			• Style	
D	W	H	Number	
32"	66"	29"	TS3BCWM	
:	:	:	:	

Campfire Half Lounge

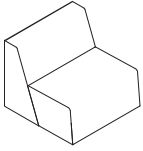

Tip: Campfire half lounges can be ordered as a single or multi-fabric upholstery.

Standard Includes	Required to Specify
<ul style="list-style-type: none"> ▶ See <i>Seating Specification Guide</i> for product details. • Fully upholstered armless lounge: fabric price group 1 • Foot: black plastic • Shipped fully assembled • Meets Cal. 117 requirements 	<ul style="list-style-type: none"> 1 Style number 2 Fabric color number for upholstery 3 Options, if selected (see below) ▶ See <i>Surface Materials</i>, page 480.

Options		Required to Specify
Surface Materials	<p>Single upholstery fabric</p> <ul style="list-style-type: none"> • Fabric price group 1 • Fabric price group 2 • Fabric price group 3 • Fabric price group 5 • Fabric price group 6 <p>Multiple upholstery fabric</p> <ul style="list-style-type: none"> • Different fabric on seat and back <p>① Fabric on seat</p> <ul style="list-style-type: none"> • Fabric price group 1 • Fabric price group 2 • Fabric price group 3 • Fabric price group 5 • Fabric price group 6 <p>② Fabric on back</p> <ul style="list-style-type: none"> • Fabric price group 1 • Fabric price group 2 • Fabric price group 3 • Fabric price group 5 • Fabric price group 6 	<p>Specify fabric color number. Specify fabric color number. Specify fabric color number. Specify fabric color number.</p> <hr/> <p>Add M to half lounge chair style number and select fabric color number for: 1 Seat, 2 Back</p> <p>Specify fabric color number. Specify fabric color number. Specify fabric color number. Specify fabric color number.</p> <hr/> <p>Specify fabric color number. Specify fabric color number. Specify fabric color number. Specify fabric color number.</p>

Specification Information				
Dimensions			Style	
D	W	H	Number	
32"	33"	29"	TS3HL	

Lounge Seating

Campfire Half Lounge—Waterfall

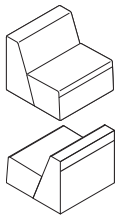

Tip: Waterfall seams are located at the top of the back, the front edge of the seat, 3½" below the front edge seam and 3½" below the top edge seam on the back of the lounge.

Tip: One thread color is used on waterfall lounges with multiple fabrics. The thread color used on the waterfall upholstery will be used on the entire unit.

*Tip: Order ganging brackets **TS3GANGING** to gang units together for more stable applications.*

Standard Includes	Required to Specify
<ul style="list-style-type: none"> ▶ See <i>Seating Specification Guide</i> for product details. • Fully upholstered armless lounge: fabric price group 1 • Foot: black plastic • Shipped fully assembled • Meets Cal. 117 requirements • Multiple upholstery fabric 	<ul style="list-style-type: none"> 1 Style number 2 Fabric color number for upholstery 3 Options, if selected (see below) ▶ See <i>Surface Materials</i>, page 480.

Options		Required to Specify
Surface Materials	<p>Single upholstery fabric</p> <ul style="list-style-type: none"> • Fabric price group 1 • Fabric price group 2 • Fabric price group 3 • Fabric price group 5 • Fabric price group 6 <p>Multiple upholstery fabric</p> <p>① Fabric on seat</p> <ul style="list-style-type: none"> • Fabric price group 1 • Fabric price group 2 • Fabric price group 3 • Fabric price group 5 • Fabric price group 6 <p>② Fabric on back</p> <ul style="list-style-type: none"> • Fabric price group 1 • Fabric price group 2 • Fabric price group 3 • Fabric price group 5 • Fabric price group 6 	<ul style="list-style-type: none"> Specify fabric color number. Specify fabric color number. Specify fabric color number. Specify fabric color number. Specify fabric color number. <ul style="list-style-type: none"> Specify fabric color number. Specify fabric color number. Specify fabric color number. Specify fabric color number. Specify fabric color number.

Specification Information				
• Dimensions			• Style	
D	W	H	• Number	
32"	33"	29"	TS3HLWM	

90° Corner Lounges

Tip: 90° Corner Lounges available inside or outside facing.

Tip: When creating an application using Big or Half Lounges, specify the Big and Half Lounges with a seam for a cohesive design aesthetic.

Tip: Campfire Corner Lounges can be ordered as a single or multi-fabric upholstery.

Tip: Order ganging brackets **TS3GANGING** to gang units together for more stable applications.

Standard Includes	Required to Specify
-------------------	---------------------

- | | |
|---|--|
| ▶ See <i>Seating Specification Guide</i> for product details. | <ul style="list-style-type: none"> Fully upholstered armless corner lounge: fabric price group 1 Foot: black plastic Shipped fully assembled Meets Cal. 117 requirements |
| | <ul style="list-style-type: none"> 1 Style number 2 Fabric color number for upholstery 3 Options, if selected (see below) <p>▶ See <i>Surface Materials</i>, page 480.</p> |

Options	Required to Specify
---------	---------------------

- | | | |
|--------------------------|--|--|
| Surface Materials | Single upholstery fabric <ul style="list-style-type: none"> Fabric price group 1 Fabric price group 2 Fabric price group 3 Fabric price group 5 Fabric price group 6 | <ul style="list-style-type: none"> Specify fabric color number. Specify fabric color number. Specify fabric color number. Specify fabric color number. Specify fabric color number. |
| | Multiple upholstery fabric <ul style="list-style-type: none"> Different fabric on seat and back | <ul style="list-style-type: none"> Add suffix M to Half Lounge chair style number and select fabric color number for: 1 Seat, 2 Back |
| | ① Fabric on seat <ul style="list-style-type: none"> Fabric price group 1 Fabric price group 2 Fabric price group 3 Fabric price group 5 Fabric price group 6 | <ul style="list-style-type: none"> Specify fabric color number. Specify fabric color number. Specify fabric color number. Specify fabric color number. Specify fabric color number. |
| | ② Fabric on back <ul style="list-style-type: none"> Fabric price group 1 Fabric price group 2 Fabric price group 3 Fabric price group 5 Fabric price group 6 | <ul style="list-style-type: none"> Specify fabric color number. Specify fabric color number. Specify fabric color number. Specify fabric color number. Specify fabric color number. |

Specification Information			
---------------------------	--	--	--

- | | |
|--------------|---------|
| • Dimensions | • Style |
| D W H | Number |

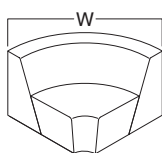

Inside Corner Lounge

32"	54 1/2"	29"	TS3CRIN90S
-----	---------	-----	-------------------



Outside Corner Lounge

32"	55 1/4"	29"	TS3CROUT90S
-----	---------	-----	--------------------

Campfire 90° Corner Lounges—Waterfall

Tip: 90° corner lounges available inside or outside facing.

Tip: Waterfall seams are located at the top of the back, the front edge of the seat, 3½" below the front edge seam and 3½" below the top edge seam on the back of the lounge.

Tip: When creating an application using big or half lounges, specify the big and half lounges with a seam for a cohesive design aesthetic.

Tip: One thread color is used on waterfall lounges with multiple fabrics. The thread color used on the waterfall upholstery will be used on the entire unit.

*Tip: Order ganging brackets **TS3GANGING** to gang units together for more stable applications.*

Standard Includes	Required to Specify
<ul style="list-style-type: none"> ▶ See <i>Seating Specification Guide</i> for product details. • Fully upholstered armless corner lounge: fabric price group 1 • Multiple upholstery fabric • Foot: black plastic • Shipped fully assembled • Meets Cal. 117 requirements 	<ul style="list-style-type: none"> 1 Style number 2 Fabric color number for upholstery 3 Options, if selected (see below) ▶ See <i>Surface Materials</i>, page 480.

Options		Required to Specify
Surface Materials	Single upholstery fabric	
	<ul style="list-style-type: none"> • Fabric price group 1 • Fabric price group 2 • Fabric price group 3 • Fabric price group 5 • Fabric price group 6 	<ul style="list-style-type: none"> Specify fabric color number. Specify fabric color number. Specify fabric color number. Specify fabric color number. Specify fabric color number.
	Multiple upholstery fabric	
	① Fabric on seat	
	<ul style="list-style-type: none"> • Fabric price group 1 • Fabric price group 2 • Fabric price group 3 • Fabric price group 5 • Fabric price group 6 	<ul style="list-style-type: none"> Specify fabric color number. Specify fabric color number. Specify fabric color number. Specify fabric color number. Specify fabric color number.
	② Fabric on back	
	<ul style="list-style-type: none"> • Fabric price group 1 • Fabric price group 2 • Fabric price group 3 • Fabric price group 5 • Fabric price group 6 	<ul style="list-style-type: none"> Specify fabric color number. Specify fabric color number. Specify fabric color number. Specify fabric color number. Specify fabric color number.

Specification Information

• Dimensions			• Style
D	W	H	Number
:	:	:	:
:	:	:	:

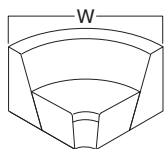

Inside Corner Lounge

32"	54½"	29"	TS3CRIN90WM
:	:	:	:

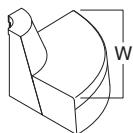

Outside Corner Lounge

32"	55¼"	29"	TS3CROUT90WM
:	:	:	:

60° Corner Lounges

Tip: 60° Corner Lounges available inside or outside facing.

Tip: When creating an application using Big or Half Lounges, specify the Big and Half Lounges with a seam and a cohesive design aesthetic.

Tip: Campfire Corner Lounges can be ordered as a single or multi-fabric upholstery.

Tip: Order ganging brackets **TS3GANGING** to gang units together for more stable applications.

Standard Includes	Required to Specify
<ul style="list-style-type: none"> See <i>Seating Specification Guide</i> for product details. Fully upholstered armless corner lounge: fabric price group 1 Foot: black plastic Shipped fully assembled Meets Cal. 117 requirements 	<ul style="list-style-type: none"> 1 Style number 2 Fabric color number for upholstery 3 Options, if selected (see below) See <i>Surface Materials</i>, page 480.

Options	Required to Specify
<p>Surface Materials</p> <p>Single upholstery fabric</p> <ul style="list-style-type: none"> Fabric price group 1 Fabric price group 2 Fabric price group 3 Fabric price group 5 Fabric price group 6 <p>Multiple upholstery fabric</p> <ul style="list-style-type: none"> Different fabric on seat and back <p>① Fabric on seat</p> <ul style="list-style-type: none"> Fabric price group 1 Fabric price group 2 Fabric price group 3 Fabric price group 5 Fabric price group 6 <p>② Fabric on back</p> <ul style="list-style-type: none"> Fabric price group 1 Fabric price group 2 Fabric price group 3 Fabric price group 5 Fabric price group 6 	<p>Specify fabric color number.</p> <p>Specify fabric color number.</p> <p>Specify fabric color number.</p> <p>Specify fabric color number.</p> <p>Specify fabric color number.</p> <p>Add suffix M to Half Lounge chair style number and select fabric color number for: 1 Seat, 2 Back</p> <p>Specify fabric color number.</p> <p>Specify fabric color number.</p> <p>Specify fabric color number.</p> <p>Specify fabric color number.</p> <p>Specify fabric color number.</p> <p>Specify fabric color number.</p> <p>Specify fabric color number.</p> <p>Specify fabric color number.</p> <p>Specify fabric color number.</p>

Specification Information

Dimensions			Style
D	W	H	Number

Inside Corner Lounge

32"	38 1/2"	29"	TS3CRIN60S
-----	---------	-----	-------------------

Outside Corner Lounge

32"	39 1/4"	29"	TS3CROUT60S
-----	---------	-----	--------------------

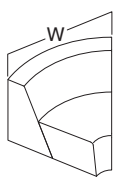

Lounge Seating

Campfire 60° Corner Lounges—Waterfall

Tip: 60° corner lounges available inside or outside facing.

Tip: Waterfall seams are located at the top of the back, the front edge of the seat, 3½" below the front edge seam and 3½" below the top edge seam on the back of the lounge.

Tip: When creating an application using big or half lounges, specify the big and half lounges with a seam for a cohesive design aesthetic.

Tip: One thread color is used on waterfall lounges with multiple fabrics. The thread color used on the waterfall upholstery will be used on the entire unit.

*Tip: Order ganging brackets **TS3GANGING** to gang units together for more stable applications.*

Standard Includes	Required to Specify
<ul style="list-style-type: none"> ▶ See <i>Seating Specification Guide</i> for product details. Fully upholstered armless corner lounge: fabric price group 1 Multiple upholstery fabric Foot: black plastic Shipped fully assembled Meets Cal. 117 requirements 	<ul style="list-style-type: none"> 1 Style number 2 Fabric color number for upholstery 3 Options, if selected (see below) ▶ See <i>Surface Materials</i>, page 480.

Options		Required to Specify
Surface Materials	<p>Single upholstery fabric</p> <ul style="list-style-type: none"> Fabric price group 1 Fabric price group 2 Fabric price group 3 Fabric price group 5 Fabric price group 6 <p>Multiple upholstery fabric</p> <p>① Fabric on seat</p> <ul style="list-style-type: none"> Fabric price group 1 Fabric price group 2 Fabric price group 3 Fabric price group 5 Fabric price group 6 <p>② Fabric on back</p> <ul style="list-style-type: none"> Fabric price group 1 Fabric price group 2 Fabric price group 3 Fabric price group 5 Fabric price group 6 	<ul style="list-style-type: none"> Specify fabric color number. Specify fabric color number. Specify fabric color number. Specify fabric color number. Specify fabric color number. Specify fabric color number. Specify fabric color number. Specify fabric color number. Specify fabric color number. Specify fabric color number.

Specification Information			
• Dimensions		• Style	
D	W	H	Number
:	:	:	:
:	:	:	:

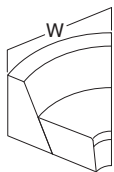

Inside Corner Lounge

32" 38½" 29" **TS3CRIN60WM**



Outside Corner Lounge

32" 39¼" 29" **TS3CROUT60WM**

Campfire Ganging Brackets

Standard Includes	Required to Specify
<ul style="list-style-type: none"> ▶ See <i>Seating Specification Guide</i> for product details. • Set of two ganging brackets: black plastic • Hardware kit 	<ul style="list-style-type: none"> 1 Style number
Specification Information	
<ul style="list-style-type: none"> • Style Number 	
TS3GANGING	

Campfire Wedge

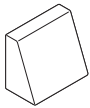

Tip: Wedge connects only to big or half lounge, not corner lounges.

Standard Includes		Required to Specify
<ul style="list-style-type: none"> ▶ See <i>Seating Specification Guide</i> for product details. 	<ul style="list-style-type: none"> • Fully upholstered wedge: fabric price group 1 • Foot: black plastic • Deck stitch detail • Connecting hardware 	<ul style="list-style-type: none"> 1 Style number 2 Fabric color number for upholstery 3 Options, if selected (see below) ▶ See <i>Surface Materials</i>, page 480.
Options		Required to Specify
Surface Materials	Upholstery	
	<ul style="list-style-type: none"> • Fabric price group 1 • Fabric price group 2 • Fabric price group 3 • Fabric price group 5 • Fabric price group 6 	<ul style="list-style-type: none"> Specify fabric color number. Specify fabric color number. Specify fabric color number. Specify fabric color number.
Specification Information		
<ul style="list-style-type: none"> • Style Number 		
TS3WG		

Visalia Lounge Seating

DESIGN COALESSE DESIGN GROUP

Tip: Fabrics will appear loose with comfort wrinkles when upholstered.

Tip: All cushions are attached.

Standard Includes	Required to Specify
<ul style="list-style-type: none"> ▶ See <i>Coalesce Seating Specification Guide</i> for product details. • Frame: unibody construction with finger jointed plywood • Cast aluminum base: group 1 paint • Upholstery: multiple densities of polyurethane foams and polyester fiber on seat and back 	<ol style="list-style-type: none"> 1 Style number 2 Fabric color number for seat, back, and arms 3 Paint color number for base: <ul style="list-style-type: none"> 4138 Graphite Gloss Black Matte 4141 Platinum Matte 4145 Milk Gloss 4180 Graphite Matte 4242 Milk Smooth 4710 Low Gloss Black 4 Options, if selected (see below) <p>▶ See <i>Surface Materials</i>, page 480.</p>

Options	Required to Specify
Surface Materials	Specify paint color number.
Base <ul style="list-style-type: none"> • Group 3 paint 	
Acrylic backer <ul style="list-style-type: none"> • Lounge chair with single fabric • 2-seat lounge with single fabric • 3-seat lounge with single fabric 	Specify with acrylic backer. Specify with acrylic backer. Specify with acrylic backer.

Specification Information

Lounge Chair

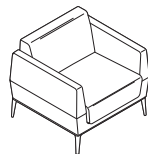

Overall: 29"D 31¾"W 28"H
 Seat height: 16¼"H
 Arm height to the floor: 23"H
 Inside: 19"D 23"W 16¼"H

2-Seat Lounge

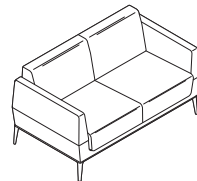

Overall: 29"D 53¾"W 28"H
 Seat height: 16¼"H
 Arm height to the floor: 23"H
 Inside: 19"D 45"W 16¼"H

3-Seat Lounge

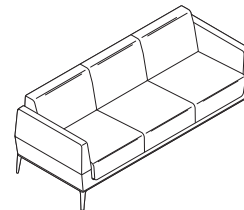

Overall: 29"D 73¾"W 28"H
 Seat height: 16¼"H
 Arm height to the floor: 23"H
 Inside: 19"D 65"W 16¼"H

Style Number	Upholstery	Fabric Groups:					
		1	2	3	5	6	

Lounge Chair with Single Fabric

COJHL100	•	•	•	•	•
----------	---	---	---	---	---

2-Seat Lounge with Single Fabric

COJHL200	•	•	•	•	•
----------	---	---	---	---	---

3-Seat Lounge with Single Fabric

COJHL300	•	•	•	•	•
----------	---	---	---	---	---

Shortcut

Five-Star Base Chair



Tip: Upholstery is only applicable if seat cushion is a selected option.

Tip: Craft in upholstery cautions the use of stripes and patterns on Shortcut. Please use fabric database when specifying.

Tip: Hard dual-wheel casters are for use on carpet. Use on hard surfaces, including floor mats, will affect chair stability and may result in personal injury.

Standard Includes		Required to Specify
<ul style="list-style-type: none"> ▶ See <i>Seating Specification Guide</i> for product details. 	<ul style="list-style-type: none"> • Seat shell: plastic price group 1 • Five-star base: 6205 Black plastic • Pneumatic seat height • Hard dual-wheel casters: 6205 Black • Shipped ready to assemble • Meets Cal. 117 requirements 	<ul style="list-style-type: none"> 1 Style number 2 Color number for base 3 Plastic color number for shell 4 Options, if selected (see below) ▶ See <i>Surface Materials</i>, page 480.

Options		Required to Specify
Seat Cushion	<ul style="list-style-type: none"> • Cushion 	Specify <i>with cushion</i> and specify fabric color number.
Surface Materials	Upholstery <ul style="list-style-type: none"> • Fabric price group 1 • Fabric price group 2 • Fabric price group 3 • Fabric price group 5 • Fabric price group 6 	<ul style="list-style-type: none"> Specify fabric color number. Specify fabric color number. Specify fabric color number. Specify fabric color number. Specify fabric color number.
	Base <ul style="list-style-type: none"> • Platinum metallic 	Specify <i>with 4799 Platinum Metallic</i> .
Casters	<ul style="list-style-type: none"> • Hard casters • Soft dual-wheel casters for use on hard floors 	<ul style="list-style-type: none"> Specify <i>with hard casters</i>. Specify <i>with soft casters</i>.
Glides	<ul style="list-style-type: none"> • Non-marring plastic glides 	Specify <i>with glides</i> .

Specification Information	
• Style Number	
• TS31201A	

Shortcut

Five-Star Base Stool

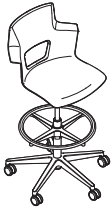

Tip: Upholstery is only applicable if seat cushion is a selected option.

Tip: Craft in upholstery cautions the use of stripes and patterns on Shortcut. Please use fabric database when specifying.

Tip: Hard dual-wheel casters are for use on carpet. Use on hard surfaces, including floor mats, will affect chair stability and may result in personal injury.

Standard Includes		Required to Specify
<ul style="list-style-type: none"> ▶ See <i>Seating Specification Guide</i> for product details. 	<ul style="list-style-type: none"> • Seat shell: plastic price group 1 • Five-star base: 6205 Black plastic • Pneumatic seat height • Hard dual-wheel casters: 6205 Black • Shipped ready to assemble • Meets Cal. 117 requirements 	<ul style="list-style-type: none"> 1 Style number 2 Color number for base 3 Plastic color number for shell 4 Options, if selected (see below) ▶ See <i>Surface Materials</i>, page 480.

Options		Required to Specify
Seat Cushion	<ul style="list-style-type: none"> • Cushion 	Specify <i>with cushion</i> and specify fabric color number.
Surface Materials	<p>Upholstery</p> <ul style="list-style-type: none"> • Fabric price group 1 • Fabric price group 2 • Fabric price group 3 • Fabric price group 5 • Fabric price group 6 <p>Base</p> <ul style="list-style-type: none"> • Platinum metallic 	<ul style="list-style-type: none"> Specify fabric color number. Specify fabric color number. Specify fabric color number. Specify fabric color number. Specify fabric color number. <p>Specify <i>with 4799 Platinum Metallic</i>.</p>
Casters	<ul style="list-style-type: none"> • Hard casters • Soft dual-wheel casters for use on hard floors 	<ul style="list-style-type: none"> Specify <i>with hard casters</i>. Specify <i>with soft casters</i>.
Glides	<ul style="list-style-type: none"> • Non-marring plastic glides 	Specify <i>with glides</i> .

Specification Information
<ul style="list-style-type: none"> • Style Number • •
TS31202B
•

Five-Star Base Chair with Personal Worksurface



Standard Includes		Required to Specify
<ul style="list-style-type: none"> ▶ See <i>Seating Specification Guide</i> for product details. 	<ul style="list-style-type: none"> • Seat shell: plastic price group 1 • Five-star base: 6205 Black plastic • Pneumatic seat height • Hard dual-wheel casters: 6205 Black • Metal components: paint • Swivel seat • Personal Worksurface: plastic • Shipped ready to assemble • Meets Cal. 117 requirements 	<ol style="list-style-type: none"> 1 Style number 2 Color number for base 3 Plastic color number for shell 4 Paint for metal components 5 Plastic color number for Personal Worksurface 6 Options, if selected (see below) <ul style="list-style-type: none"> ▶ See <i>Surface Materials</i>, page 480.

Tip: Upholstery is only applicable if seat cushion is a selected option.

Tip: Craft in upholstery cautions the use of stripes and patterns on Shortcut. Please use fabric database when specifying.

Tip: Metal components include shell bracket and personal worksurface arm that default to match the base finish.

Tip: Hard dual-wheel casters are for use on carpet. Use on hard surfaces, including floor mats, will affect chair stability and may result in personal injury.

Options		Required to Specify	
Seat Cushion	<ul style="list-style-type: none"> • Cushion 	Specify <i>with cushion</i> and specify fabric color number.	
Surface Materials	Upholstery	<ul style="list-style-type: none"> • Fabric price group 1 • Fabric price group 2 • Fabric price group 3 • Fabric price group 5 • Fabric price group 6 	<ul style="list-style-type: none"> Specify fabric color number. Specify fabric color number. Specify fabric color number. Specify fabric color number.
	Base	<ul style="list-style-type: none"> • Platinum metallic 	Specify <i>with 4799 Platinum Metallic</i> .
	Cup Holder	<ul style="list-style-type: none"> • Cup holder 	Specify <i>with cup holder</i> .
Tablet Stand	<ul style="list-style-type: none"> • Tablet stand 	Specify <i>with tablet stand</i> .	
Casters	<ul style="list-style-type: none"> • Hard casters • Soft dual-wheel casters for use on hard floors 	<ul style="list-style-type: none"> Specify <i>with hard casters</i>. Specify <i>with soft casters</i>. 	
Glides	<ul style="list-style-type: none"> • Non-marring plastic glides 	Specify <i>with glides</i> .	

Specification Information	
• Style Number	
• TS31209A	

Shortcut

X Base Chair



Tip: Upholstery is only applicable if seat cushion is a selected option.

Tip: Craft in upholstery cautions the use of stripes and patterns on Shortcut. Please use fabric database when specifying.

Standard Includes		Required to Specify
<ul style="list-style-type: none"> ▶ See <i>Seating Specification Guide</i> for product details. 	<ul style="list-style-type: none"> • Seat shell: plastic price group 1 • Steel wire frame base: paint price group 1 • Standard glides • Ships fully assembled • Meets Cal. 117 requirements 	<ul style="list-style-type: none"> 1 Style number 2 Paint color number for base 3 Plastic color number for shell 4 Options, if selected (see below) ▶ See <i>Surface Materials</i>, page 480.

Options		Required to Specify
Seat Cushion	<ul style="list-style-type: none"> • Cushion 	Specify with soft, felt glides.
Surface Materials	<p>Upholstery</p> <ul style="list-style-type: none"> • Fabric price group 1 • Fabric price group 2 • Fabric price group 3 • Fabric price group 5 • Fabric price group 6 <p>Base</p> <ul style="list-style-type: none"> • Paint price group 1 • Paint price group 2 	<ul style="list-style-type: none"> Specify fabric color number. Specify fabric color number. Specify fabric color number. Specify fabric color number. <ul style="list-style-type: none"> Specify paint color number. Specify paint color number.
Glides	<ul style="list-style-type: none"> • Soft, felt glides 	Specify with soft, felt glides.

Specification Information

• **Style Number**

TS31204A

Shortcut

X Base Stool



Tip: Upholstery is only applicable if seat cushion is a selected option.

Tip: Craft in upholstery cautions the use of stripes and patterns on Shortcut. Please use fabric database when specifying.

Standard Includes		Required to Specify
<ul style="list-style-type: none"> ▶ See <i>Seating Specification Guide</i> for product details. 	<ul style="list-style-type: none"> • Seat shell: plastic price group 1 • Steel wire frame base: paint price group 1 • Standard glides • Ships fully assembled • Meets Cal. 117 requirements 	<ul style="list-style-type: none"> 1 Style number 2 Paint color number for base 3 Plastic color number for shell 4 Options, if selected (see below) ▶ See <i>Surface Materials</i>, page 480.

Options		Required to Specify
Seat Cushion	<ul style="list-style-type: none"> • Cushion 	Specify <i>with cushion</i> and specify fabric color number.
Surface Materials	Upholstery	<ul style="list-style-type: none"> Specify fabric color number. Specify fabric color number. Specify fabric color number. Specify fabric color number. Specify fabric color number.
	Base	<ul style="list-style-type: none"> • Paint price group 1 • Paint price group 2
Glides	<ul style="list-style-type: none"> • Soft, felt glides 	Specify <i>with soft, felt glides</i> .

Specification Information
<ul style="list-style-type: none"> • Style Number • •
TS31205B
•

Shortcut

with Tripod Base

Tip: Metal components include shell bracket and personal worksurface arm if **TS31208A** is selected.

Tip: Upholstery is only applicable if seat cushion is a selected option.

Tip: Craft in upholstery cautions the use of stripes and patterns on Shortcut. Please use fabric database when specifying.

Tip: Cup holder and tablet stand are only available on shortcut with a personal worksurface.

Standard Includes		Required to Specify
<ul style="list-style-type: none"> ▶ See <i>Seating Specification Guide</i> for product details. 	<ul style="list-style-type: none"> • Seat shell: plastic price group 1 • Tripod base: plastic • Metal components: paint • Storage tray: sterling dark solid only • Swivel seat • Personal worksurface, if TS31208A selected: plastic • Hard casters: black • Ships ready to assemble • Meets Cal. 117 requirements 	<ol style="list-style-type: none"> 1 Style number 2 Plastic color number for shell 3 Plastic color number for tripod base 4 Paint number for metal components: 0835 Black 4799 Platinum Metallic 5 Plastic color number for Personal Worksurface, if selected 6 Options, if selected (see below) <ul style="list-style-type: none"> ▶ See <i>Surface Materials</i>, page 480.

Options		Required to Specify
Seat Cushion	<ul style="list-style-type: none"> • Cushion 	Specify <i>with cushion</i> and specify fabric color number.
Surface Materials	<p>Upholstery on seat cushion</p> <ul style="list-style-type: none"> • Fabric price group 1 • Fabric price group 2 • Fabric price group 3 • Fabric price group 5 • Fabric price group 6 	<ul style="list-style-type: none"> Specify fabric color number. Specify fabric color number. Specify fabric color number. Specify fabric color number.
Cup Holder	<ul style="list-style-type: none"> • On TS31208A 	Specify <i>with cup holder</i> .
Tablet Stand	<ul style="list-style-type: none"> • On TS31208A 	Specify <i>with tablet stand</i> .
Casters	<ul style="list-style-type: none"> • Soft, dual-wheel casters for use on hard floors 	Specify <i>with soft casters</i> .
Glides	<ul style="list-style-type: none"> • Glides: sterling dark solid 	Specify <i>with glides</i> .

Specification Information

• **Style Number**
:

Chair with Tripod Base

TS31207A
:

Chair with Tripod Base and Personal Worksurface

TS31208A
:

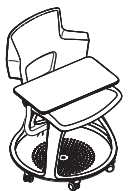
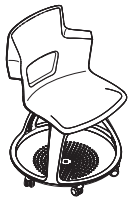

Cushion



Tip: Cushion can be optioned on when ordering any Shortcut chair or stool, or installed after purchase when ordered separately.

Standard Includes		Required to Specify
<ul style="list-style-type: none"> ▶ See <i>Seating Specification Guide</i> for product details. 	<ul style="list-style-type: none"> • Cushion: fabric price group 1 • Shipped ready to assemble • Meets Cal. 117 requirements 	<ul style="list-style-type: none"> 1 Style number 2 Fabric color number for cushion 3 Options, if selected (see below) ▶ See <i>Surface Materials</i>, page 480.

Options		Required to Specify
Surface Materials	Upholstery <ul style="list-style-type: none"> • Fabric price group 1 • Fabric price group 2 • Fabric price group 3 • Fabric price group 5 • Fabric price group 6 	<ul style="list-style-type: none"> Specify fabric color number. Specify fabric color number. Specify fabric color number. Specify fabric color number.

Specification Information

Style Number	TS31203
---------------------	----------------

Simple Chair



Tip: Cushions or slipcover can be installed after purchase and are ordered separately.

Tip: Chairs, stools, and lounge can be stacked up to four high with or without cushions and slipcovers.

Standard Includes	Required to Specify
-------------------	---------------------

- | | | |
|---|---|---|
| <ul style="list-style-type: none"> ▶ See <i>Seating Specification Guide</i> for product details. | <ul style="list-style-type: none"> • Steel frame: paint • Seat and back: plastic, default to match paint color for frame • Standard hard glides • Ships fully assembled | <ul style="list-style-type: none"> 1 Style number 2 Paint color number for chair: <ul style="list-style-type: none"> 7041 Milk Textured 7042 Shale Grey 7043 Moss 7207 Black |
|---|---|---|

Specification Information			
• Dimensions			• Style
D	W	H	Number

19 ² / ₈ "	19 ² / ₈ "	31 ⁸ / ₈ "	TSAVNCH
----------------------------------	----------------------------------	----------------------------------	----------------

Simple Stool

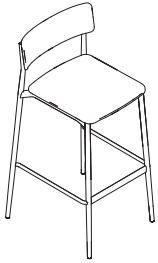

Tip: Cushions or slipcover can be installed after purchase and are ordered separately.

Tip: Chairs, stools, and lounge can be stacked up to four high with or without cushions and slipcovers.

Standard Includes	Required to Specify
<ul style="list-style-type: none"> ▶ See <i>Seating Specification Guide</i> for product details. • Steel frame: paint • Seat and back: plastic, default to match paint color for frame • Standard hard glides • Ships fully assembled 	<ul style="list-style-type: none"> 1 Style number 2 Paint color number for stool: <ul style="list-style-type: none"> 7041 Milk Textured 7042 Shale Grey 7043 Moss 7207 Black

Specification Information				
• Dimensions			• Style	
D	W	H	Number	
19 ² / ₃ "	19 ² / ₃ "	38 ⁴ / ₇ "	TSAVNST	

Simple Seat Cushion

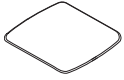

Tip: Seat and back cushions are ordered separately and can be in matching or contrasting fabrics and colors.

Tip: Chairs, stools, and lounge can be stacked up to four high with or without cushions and slipcovers.

Standard Includes		Required to Specify
<ul style="list-style-type: none"> ▶ See <i>Seating Specification Guide</i> for product details. 	<ul style="list-style-type: none"> • Cushion: fabric price group 1 • Shipped ready to assemble 	<ul style="list-style-type: none"> 1 Style number 2 Application (see Required Selections) 3 Fabric color number for cushion 4 Options, if selected (see below) ▶ See <i>Surface Materials</i>, page 480.

Required Selections		Required to Specify
Application <ul style="list-style-type: none"> • Chair • Stool 		<ul style="list-style-type: none"> Specify chair application. Specify stool application.

Options		Required to Specify
Surface Materials <ul style="list-style-type: none"> • Fabric price group 1 • Fabric price group 2 • Fabric price group 3 • Fabric price group 5 • Fabric price group 6 		<ul style="list-style-type: none"> Specify fabric color number. Specify fabric color number. Specify fabric color number. Specify fabric color number. Specify fabric color number.

Specification Information

• **Style Number**

TSAVNSC



Tip: Seat and back cushions are ordered separately and can be in matching or contrasting fabrics and colors.

Tip: Chairs, stools, and lounge can be stacked up to four high with or without cushions and slipcovers.

Standard Includes		Required to Specify
▶ See <i>Seating Specification Guide</i> for product details.	<ul style="list-style-type: none"> Cushion: fabric price group 1 Shipped ready to assemble 	<ul style="list-style-type: none"> 1 Style number 2 Application (see Required Selections) 3 Fabric color number for cushion 4 Options, if selected (see below)

Required Selections		Required to Specify
Application	<ul style="list-style-type: none"> Chair Stool 	<ul style="list-style-type: none"> Specify chair application. Specify stool application.

Options		Required to Specify
Surface Materials	<ul style="list-style-type: none"> Fabric price group 1 Fabric price group 2 Fabric price group 3 Fabric price group 5 Fabric price group 6 	<ul style="list-style-type: none"> Specify fabric color number. Specify fabric color number. Specify fabric color number. Specify fabric color number.

Specification Information

• **Style Number**
:
:

TSAVNBC
:

Simple Relaxed Slipcover



Tip: Chairs, stools, and lounge can be stacked up to four high with or without cushions and slipcovers.

Standard Includes	Required to Specify
-------------------	---------------------

<ul style="list-style-type: none"> ▶ See <i>Seating Specification Guide</i> for product details. • Slipcover: fabric price group 1 • Webbing: fabric • Shipped ready to assemble 	<ol style="list-style-type: none"> 1 Style number 2 Application (see Required Selections) 3 Fabric color number for slipcover 4 Fabric color number for webbing: <ul style="list-style-type: none"> 5JG0 Black 5JG1 Burgundy 5JG5 Red 5JG7 Green 5JG8 Navy 5 Options, if selected (see below) <ul style="list-style-type: none"> ▶ See <i>Surface Materials</i>, page 480.
--	---

Required Selections	Required to Specify
---------------------	---------------------

Application <ul style="list-style-type: none"> • Chair • Stool 	Specify chair application. Specify stool application.
---	--

Options	Required to Specify
---------	---------------------

Surface Materials <ul style="list-style-type: none"> • Fabric price group 1 • Fabric price group 2 • Fabric price group 3 • Fabric price group 5 • Fabric price group 6 	Specify fabric color number. Specify fabric color number. Specify fabric color number. Specify fabric color number. Specify fabric color number.
---	--

Specification Information

• **Style Number**
:
:

TSAVNS1
:
:



Tip: Chairs, stools, and lounge can be stacked up to four high with or without cushions and slipcovers.

Standard Includes		Required to Specify
<ul style="list-style-type: none"> ▶ See <i>Seating Specification Guide</i> for product details. 	<ul style="list-style-type: none"> • Slipcover: fabric price group 1 • Shipped ready to assemble 	<ul style="list-style-type: none"> 1 Style number 2 Application (see Required Selections) 3 Fabric color number for slipcover 4 Options, if selected (see below) ▶ See <i>Surface Materials</i>, page 480.

Required Selections		Required to Specify
Application	<ul style="list-style-type: none"> • Chair • Stool 	<ul style="list-style-type: none"> Specify chair application. Specify stool application.

Options		Required to Specify
Surface Materials	<ul style="list-style-type: none"> • Fabric price group 1 • Fabric price group 2 • Fabric price group 3 • Fabric price group 5 • Fabric price group 6 	<ul style="list-style-type: none"> Specify fabric color number. Specify fabric color number. Specify fabric color number. Specify fabric color number.

Specification Information

• **Style Number**
:
:

TSAVNS2
:
:

Move 490 Series Multi-Use Chairs

Standard Includes		Required to Specify
<ul style="list-style-type: none"> ▶ See <i>Seating Specification Guide</i> for product details. 	<ul style="list-style-type: none"> • Frame: 0835 Black paint • Back shell: plastic price group 1 • Seat shell, if selected: plastic price group 1 • Upholstery, if selected: fabric price group 1 • Arms, if selected: plastic to match back shell • Glides, if selected: plastic with hard plastic inserts • Hard, dual-wheel casters, if selected: black 	<ul style="list-style-type: none"> 1 Style number 2 Paint color number for frame 3 Plastic color number for back shell 4 Plastic color number for seat shell, if selected 5 Fabric color number for upholstery on seat and back, or seat, if selected 6 Options, if selected (see below) ▶ See <i>Surface Materials</i>, page 480.

Options		Required to Specify
Surface Materials	Upholstery on seat and back <ul style="list-style-type: none"> • Fabric price group 1 • Fabric price group 2 • Fabric price group 3 • Fabric price group 5 • Fabric price group 6 	<ul style="list-style-type: none"> Specify fabric color number. Specify fabric color number. Specify fabric color number. Specify fabric color number. Specify fabric color number.
	Frame <ul style="list-style-type: none"> • 7239 Midnight • 4799 Platinum Metallic 	<ul style="list-style-type: none"> Specify with 7239 Midnight. Specify with 4799 Platinum Metallic.
Glides	<ul style="list-style-type: none"> • Soft felt glides for use on non-carpeted floors 	<ul style="list-style-type: none"> Specify with soft glides.
Casters	<ul style="list-style-type: none"> • Soft, dual-wheel casters for use on hard floors 	<ul style="list-style-type: none"> Specify with soft casters.

Specification Information

• **Style Number**

Upholstered Seat without Arms

With Glides

490410

With Casters

490410C

Upholstered Back and Seat without Arms

With Glides

490410U

With Casters

490410UC

▶ **Specification Information, continued on next page**

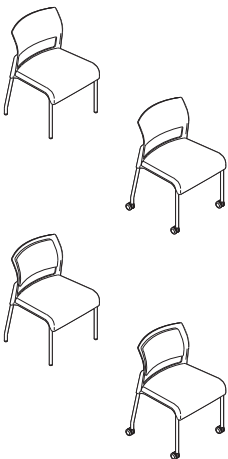

► **Specification Information, continued from previous page**

Specification Information

• **Style
Number**

Plastic Back and Seat without Arms

With Glides

490410P

With Casters

490410CP

Upholstered Seat with Arms

With Glides

490412

With Casters

490412C

Upholstered Back and Seat with Arms

With Glides

490412U

With Casters

490412UC

Plastic Back and Seat with Arms

With Glides

490412P

With Casters

490412CP

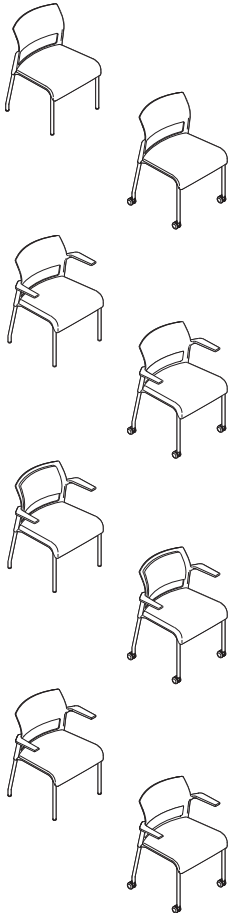

Tip: Plastic finish number must be specified for both seat and back on plastic styles.

Move 490 Series Multi-Use Stools

Standard Includes		Required to Specify
<ul style="list-style-type: none"> ▶ See <i>Seating Specification Guide</i> for product details. 	<ul style="list-style-type: none"> • Frame: 0835 Black paint • Back shell: plastic price group 1 • Seat shell, if selected: plastic price group 1 • Upholstery, if selected: fabric price group 1 • Arms, if selected: plastic to match back shell • Glides, if selected: plastic with hard plastic inserts • Hard, dual-wheel casters, if selected: black 	<ol style="list-style-type: none"> 1 Style number 2 Paint color number for frame 3 Plastic color number for back shell 4 Plastic color number for seat shell, if selected 5 Fabric color number for upholstery on seat and back, or seat, if selected 6 Options, if selected (see below) <ul style="list-style-type: none"> ▶ See <i>Surface Materials</i>, page 480.

Options		Required to Specify
Surface Materials	Upholstery on seat and back <ul style="list-style-type: none"> • Fabric price group 1 • Fabric price group 2 • Fabric price group 3 • Fabric price group 5 • Fabric price group 6 	Specify fabric color number. Specify fabric color number. Specify fabric color number. Specify fabric color number. Specify fabric color number.
	Frame <ul style="list-style-type: none"> • 7239 Midnight • 4799 Platinum Metallic 	Specify with 7239 Midnight. Specify with 4799 Platinum Metallic.
Glides	<ul style="list-style-type: none"> • Soft felt glides for use on non-carpeted floors 	Specify with soft glides.
Casters	<ul style="list-style-type: none"> • Soft, dual-wheel casters for use on hard floors 	Specify with soft casters.

Specification Information

• Style Number

Upholstered Seat without Arms

With Glides

490710

With Casters

490710C

Upholstered Back and Seat without Arms

With Glides

490710U

With Casters

490710UC

▶ Specification Information, continued on next page

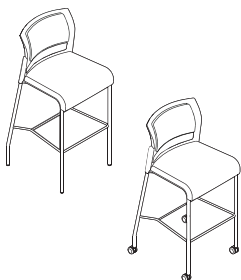

► **Specification Information, continued from previous page**

Specification Information

• **Style
Number**

Plastic Back and Seat without Arms

With Glides

490710P

With Casters

490710CP



Upholstered Seat with Arms

With Glides

490712

With Casters

490712C

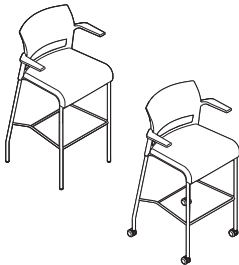

Upholstered Back and Seat with Arms

With Glides

490712U

With Casters

490712UC



Plastic Back and Seat with Arms

With Glides

490712P

With Casters

490712CP



Tip: Plastic finish number must be specified for both seat and back on plastic styles.

Max-Stacker III 477 Series Stackable Chair



Standard Includes		Required to Specify
<ul style="list-style-type: none"> ▶ See <i>Seating Specification Guide</i> for product details. 	<ul style="list-style-type: none"> • Frame: 7000 Black paint • Shell: plastic price group 1 • Glides: plastic 	<ul style="list-style-type: none"> 1 Style number 2 Seating coating color number for frame 3 Options, if selected (see below) ▶ See <i>Surface Materials</i>, page 480.

Options		Required to Specify
Surface Materials	Frame <ul style="list-style-type: none"> • 7239 Midnight • 4799 Platinum Metallic • 9201 Polished Chrome 	<ul style="list-style-type: none"> Specify with 7239 <i>Midnight</i>. Specify with 4799 <i>Platinum Metallic</i>. Specify with 9201 <i>Polished Chrome</i>.

Specification Information

• **Style Number**

477100

Empath Recliner with Fully Upholstered Arms

Empath Recliner with Fully Upholstered Arms

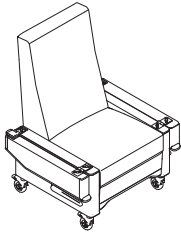

Tip: Left and right for tablet are determined when facing the front of the chair.

Tip: Tablet arm for fully upholstered arm units is not the same as tablet arm for molded urethane arm units.

Tip: Directional steering, push bar, and pull out footrest are ordered as options.

Tip: Central lock is optional on recliners not for use with sit-to-stand aid and upcharge is reflected in base prices.

Standard Includes	Required to Specify
<ul style="list-style-type: none"> ▶ See <i>Steelcase Health Volume 1 Seating Specification Guide</i> for product details. • Seat, back, arms, and front: fabric price group 1 • 23"W seat • Standard seat • Bumpers: plastic to match upper arms • Footrest scallop: <ul style="list-style-type: none"> – Plastic to match upper arms, if 23"W selected – Fabric to match front, if 26"W selected • Left-side facing recline activation • Individual locking casters • Headrest, if selected: fabric • Recliners for use with sit-to-stand aid: central lock 	<ol style="list-style-type: none"> 1 Style number 2 Fabric color number for seat, back, arms, and front 3 Options, if selected (see below) <ul style="list-style-type: none"> ▶ See <i>Surface Materials</i>, page 480.

Options	Required to Specify
Surface Materials <ul style="list-style-type: none"> • Moisture barrier on seat <ul style="list-style-type: none"> • Moisture barrier • Arm cap <ul style="list-style-type: none"> • Plastic arm cap 	<p>Specify with moisture barrier.</p> <p>Specify with 6059 Sterling Dark or 6259 Midnight.</p>
Seat Foam <ul style="list-style-type: none"> • Softer seat 	Specify with softer seat.
Seat Width <ul style="list-style-type: none"> • 26"W 	Specify with 26" seat width.
Adjustable Headrest <ul style="list-style-type: none"> • Square corners 	Specify with square corners and select fabric color number.
Heat and Massage <ul style="list-style-type: none"> • Heat only • Heat and massage 	Specify with heat. Specify with heat and massage.
Tablet Arm <ul style="list-style-type: none"> • Tablet arm for fully upholstered arms 	Specify with tablet arm, indicate left or right facing, and select thermoform color number.
Directional Steering <ul style="list-style-type: none"> • Directional steering 	Specify with directional steering.
Push Bar <ul style="list-style-type: none"> • Push bar 	Specify with push bar.
Pull Out Footrest <ul style="list-style-type: none"> • Pull out footrest 	Specify with pull out footrest.
Casters <ul style="list-style-type: none"> • Central lock 	Specify with central lock.
Backrest Recline <ul style="list-style-type: none"> • Standard recline • Dual recline 	Specify with standard recline. Specify with dual recline.
Seat and Back Cushion <ul style="list-style-type: none"> • Rounded seat and back cushion 	Specify with rounded corners.

Specification Information

Style Number	Fabric Price Group 1	Fabric Price Group 2	Fabric Price Group 3	Fabric Price Group 5	Fabric Price Group 6

Fully Upholstered Recliner

With Dual Flip-Down Arms

HR223DU	•	•	•	•	•
---------	---	---	---	---	---

Sorrel

18" Wide Stacking Chairs

With Arms and Armless

Tip: Different fabrics for the seat and back can be specified.

Tip: Chairs stack six high alone. Straight leg chairs stack ten high on a dolly.

Standard Includes	Required to Specify
-------------------	---------------------

- | Standard Includes | Required to Specify |
|---|--|
| <ul style="list-style-type: none"> ▶ See <i>Steelcase Health Volume 1 Specification Guide</i> for product details. • Seat: fabric • Back: fabric • Arm caps, if selected: plastic • Straight legs and frame: paint • Glides: black plastic • Ganging brackets, if selected: paint (ordered separately) | <ol style="list-style-type: none"> 1 Style number 2 Fabric color number for seat 3 Fabric color number for back 4 Plastic color number for arm caps, if selected 5 Paint color number for legs and frame 6 Paint color number for ganging brackets, if selected <p>▶ See <i>Surface Materials</i>, page 480.</p> |

Specification Information					
Style Number	Fabric Price Group 1	Fabric Price Group 2	Fabric Price Group 3	Fabric Price Group 5	Fabric Price Group 6

Style Number	Fabric Price Group 1	Fabric Price Group 2	Fabric Price Group 3	Fabric Price Group 5	Fabric Price Group 6
--------------	----------------------	----------------------	----------------------	----------------------	----------------------



18" Wide Stacking Chair without Arms, With Upholstered Back

SC1060SN	•	•	•	•	•
----------	---	---	---	---	---



18" Wide Stacking Chair with Arms, With Upholstered Back

SC1060SA	•	•	•	•	•
----------	---	---	---	---	---

Bariatric Stacking Chair



Tip: Different fabrics for the seat and back can be specified.

Tip: Chairs stack four high alone. Straight leg chairs stack six high on a dolly.

Standard Includes	Required to Specify
-------------------	---------------------

- | Standard Includes | Required to Specify |
|--|--|
| <ul style="list-style-type: none"> ▶ See <i>Steelcase Health Volume 1 Specification Guide</i> for product details. • Seat: fabric • Back: fabric • Arm caps: plastic • Straight legs and frame: paint • Glides: black plastic • Ganging brackets, if selected: paint (ordered separately) | <ol style="list-style-type: none"> 1 Style number 2 Fabric color number for seat 3 Fabric color number for back 4 Plastic color number for arm caps, if selected 5 Paint color number for legs and frame 6 Paint color number for ganging brackets, if selected <p>▶ See <i>Surface Materials</i>, page 480.</p> |

Specification Information					
Style Number	Fabric Price Group 1	Fabric Price Group 2	Fabric Price Group 3	Fabric Price Group 5	Fabric Price Group 6

Style Number	Fabric Price Group 1	Fabric Price Group 2	Fabric Price Group 3	Fabric Price Group 5	Fabric Price Group 6
--------------	----------------------	----------------------	----------------------	----------------------	----------------------

Bariatric Stacking Chair With Upholstered Back

SC1065SA	•	•	•	•	•
----------	---	---	---	---	---

Answer In-Line Base Panel Junctions—Thin Trim

Answer In-Line Base Panel Junctions—Thin Trim



Tip: In-line base panel junctions do not require junction cap and trim.

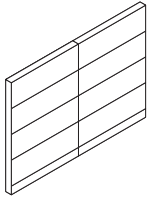

Standard Includes	Required to Specify
<ul style="list-style-type: none"> ▶ See <i>Answer Solutions Specification Guide</i> for product details. 	<ul style="list-style-type: none"> • Junction • Aligner
	Style number

Specification Information	
• Corresponding Panel Height	• Style Number
30"	TS730TIPJ
36"	TS736TIPJ
42"	TS742TIPJ
48"	TS748TIPJ
54"	TS754TIPJ
66"	TS766TIPJ
78"	TS778TIPJ
:	:

Answer L and T Same Height Base Panel Junctions—Thin Trim

Standard Includes		Required to Specify
<ul style="list-style-type: none"> ▶ See <i>Answer Solutions Specification Guide</i> for product details. 	<ul style="list-style-type: none"> • Junction • Inside corner light seal(s) • Vertical trim and junction cap on L and T junction: paint price group 1 • Aligner(s) 	<ul style="list-style-type: none"> 1 Style number 2 Paint color number for trim and junction cap 3 Options, if selected (see below) ▶ See <i>Surface Materials</i>, page 480.

Options		Required to Specify
Surface Materials	Trim <ul style="list-style-type: none"> • Paint price group 1 • Paint price group 2 	Specify paint color number. Specify paint color number.
	<ul style="list-style-type: none"> • Omit trim 	Specify <i>with omit trim</i> .

Tip: Omit trim option is used when stacking on base panel junctions. Vertical trim should be specified separately to span the full height of the base panel junction plus the stacking junction.

Tip: Remember to specify necessary junction cap and aligners if the omit trim option is selected.

Specification Information

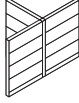
	L Base Panel Junctions with Thin Trim	T Base Panel Junctions with Thin Trim
		
• Corresponding Panel Height	• Style Number	• Style Number

Painted Trim		
30"	TS730TLPJ	TS730TTPJ
36"	TS736TLPJ	TS736TTPJ
42"	TS742TLPJ	TS742TTPJ
48"	TS748TLPJ	TS748TTPJ
54"	TS754TLPJ	TS754TTPJ
66"	TS766TLPJ	TS766TTPJ
78"	TS778TLPJ	TS778TTPJ
:	:	:

Answer X Same Height Base Panel Junctions—Thin Trim

Answer X Same Height
Base Panel
Junctions—Thin Trim

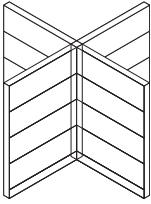

Tip: Omit trim option is used when stacking on base panel junctions.

Tip: Remember to specify necessary junction cap and aligners if the omit trim option is selected.

Standard Includes		Required to Specify
<ul style="list-style-type: none"> ▶ See <i>Answer Solutions Specification Guide</i> for product details. 	<ul style="list-style-type: none"> • Junction • Inside corner light seals • Trim/junction cap: paint • Aligners 	<ul style="list-style-type: none"> 1 Style number 2 Paint color number for junction cap 3 Options, if selected (see below) ▶ See <i>Surface Materials</i>, page 480.

Options		Required to Specify
Surface Materials	Trim <ul style="list-style-type: none"> • Paint price group 1 • Paint price group 2 	Specify paint color number. Specify paint color number.
	<ul style="list-style-type: none"> • Omit trim 	Specify <i>with omit trim</i> .

Specification Information	
• Corresponding Panel Height	• Style Number
:	:
:	:
:	:

Painted Trim	
30"	TS730TXPJ
36"	TS736TXPJ
42"	TS742TXPJ
48"	TS748TXPJ
54"	TS754TXPJ
66"	TS766TXPJ
78"	TS778TXPJ
:	:

Answer End-of-Run Base Panel Junctions—Thin Trim



Tip: End-of-run trim adds 1/2" to footprint.

Tip: Omit trim option is used when stacking on base panel junctions. Vertical trim should be specified separately to span the full height of the base panel junction plus the stacking junction.

Standard Includes		Required to Specify
<ul style="list-style-type: none"> ▶ See <i>Answer Solutions Specification Guide</i> for product details. 	<ul style="list-style-type: none"> • Junction • Trim on end-of-run junction: paint price group 1 • Aligner 	<ul style="list-style-type: none"> 1 Style number 2 Paint color number for trim 3 Options, if selected (see below) ▶ See <i>Surface Materials</i>, page 480.

Options		Required to Specify
Surface Materials	Trim <ul style="list-style-type: none"> • Paint price group 1 • Paint price group 2 	<ul style="list-style-type: none"> Specify paint color number. Specify paint color number.
	<ul style="list-style-type: none"> • Omit trim 	<ul style="list-style-type: none"> Specify <i>with omit trim</i>.

Specification Information

Corresponding Panel Height	Style Number
:	:
:	:

Painted Trim

30"	TS730TEPJ
36"	TS736TEPJ
42"	TS742TEPJ
48"	TS748TEPJ
54"	TS754TEPJ
66"	TS766TEPJ
78"	TS778TEPJ
:	:

Answer V and Y Same Height Base Panel Junctions—Thin Trim

Answer V and Y Same
Height Base Panel
Junctions—Thin Trim

Standard Includes		Required to Specify
<ul style="list-style-type: none"> ▶ See <i>Answer Solutions Specification Guide</i> for product details. 	<ul style="list-style-type: none"> • Junction • Vertical trim and junction cap on V junction: paint price group 1 • Trim/junction cap on Y junction: paint price group 1 • Aligner(s) 	<ul style="list-style-type: none"> 1 Style number 2 Paint color number for trim and junction cap 3 Options, if selected (see below) ▶ See <i>Surface Materials</i>, page 480.

Options		Required to Specify
Surface Materials	Trim <ul style="list-style-type: none"> • Paint price group 1 • Paint price group 2 	Specify paint color number. Specify paint color number.
	<ul style="list-style-type: none"> • Omit trim 	Specify <i>with omit trim</i> .

Tip: Omit trim option is used when stacking on base panel junctions. Vertical trim should be specified separately to span the full height of the base panel junction plus the stacking junction.

Tip: Remember to specify necessary junction cap and aligners if the omit trim option is selected.

Specification Information

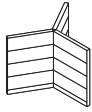
	V Base Panel Junctions with Thin Trim	Y Base Panel Junctions with Thin Trim
		
• Corresponding Panel Height	• Style Number	• Style Number
:	:	:

Painted Trim		
30"	TS730TVPJ	TS730TYPJ
36"	TS736TVPJ	TS736TYPJ
42"	TS742TVPJ	TS742TYPJ
48"	TS748TVPJ	TS748TYPJ
54"	TS754TVPJ	TS754TYPJ
66"	TS766TVPJ	TS766TYPJ
78"	TS778TVPJ	TS778TYPJ
:	:	:

Answer In-Line Change-of-Height Junctions—Thin Trim

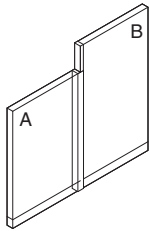

Tip: Junction includes:

- In-line base junction
- End-of-run stacking junction
- Stacking fork
- End-of-run change-of-height trim
- Aligner

Tip: Remember to specify a stacking horizontal frame package with this application, unless there is a window in the top position of the taller panel.

Tip: Omit trim option omits change-of-height trim. This option is used when stacking on base panel junctions. Change-of-height trims should be specified separately to span the full height of the base panel junction plus the stacking junction.

Standard Includes	Required to Specify
<ul style="list-style-type: none"> ▶ See <i>Answer Solutions Specification Guide</i> for product details. • Junction • Change-of-height trim: paint price group 1 • Aligner 	<ul style="list-style-type: none"> 1 Style number 2 Paint color number for trim ▶ See <i>Surface Materials</i>, page 480.

Options	Required to Specify
<p>Surface Materials</p> <p>Trim</p> <ul style="list-style-type: none"> • Paint price group 1 • Paint price group 2 • Omit trim 	<ul style="list-style-type: none"> Specify paint color number. Specify paint color number. Specify <i>with omit trim</i>.

Specification Information		
Corresponding Panel Height		Style Number
A	B	
30"	36"	TS73QTCIJ
30"	42"	TS734TCIJ
30"	48"	TS738TCIJ
30"	54"	TS735TCIJ
30"	66"	TS736TCIJ
36"	42"	TS7Q4TCIJ
36"	48"	TS7Q8TCIJ
36"	54"	TS7Q5TCIJ
36"	66"	TS7Q6TCIJ
42"	48"	TS748TCIJ
42"	54"	TS745TCIJ
42"	66"	TS746TCIJ
42"	78"	TS747TCIJ
48"	66"	TS786TCIJ
48"	54"	TS785TCIJ
54"	66"	TS756TCIJ
54"	78"	TS757TCIJ
54"	90"	TS759TCIJ
66"	78"	TS767TCIJ
66"	90"	TS769TCIJ
78"	90"	TS779TCIJ
:	:	:

Answer L Change-of-Height Junctions—Thin Trim

Answer L
Change-of-Height
Junctions—Thin Trim

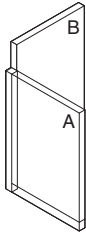

Tip: Junction includes:

- L change-of-height junction
- Inside corner light seal
- L vertical trim
- End-of-run change-of-height trim
- Change-of-height junction cap
- Aligners

Tip: Omit trim option omits all vertical and change-of-height trim. This option is used when stacking on base junctions.

Vertical and change-of-height trim should be specified separately to span the full height of the base junction plus the stacking junction.

Tip: Remember to specify necessary junction cap and aligners if the omit trim option is selected.

Tip: Change-of-height junction ships right-handed. For a left-handed junction a post will need to be moved during installation.

Standard Includes	Required to Specify
<ul style="list-style-type: none"> ▶ See <i>Answer Solutions Specification Guide</i> for product details. • Junction • Inside corner light seal • Change-of-height trim and junction cap: paint price group 1 • Aligner 	<ul style="list-style-type: none"> 1 Style number 2 Paint color number for trim and junction cap 3 Options, if selected (see below) ▶ See <i>Surface Materials</i>, page 480.

Options	Required to Specify
Surface Materials	Specify paint color number. Specify paint color number.
Trim <ul style="list-style-type: none"> • Paint price group 1 • Paint price group 2 • Omit trim 	Specify <i>with omit trim</i> .

Specification Information		
Corresponding Panel Height		Style Number
A	B	
30"	36"	TS73QTCLJ
30"	42"	TS734TCLJ
30"	48"	TS738TCLJ
30"	54"	TS735TCLJ
30"	66"	TS736TCLJ
36"	42"	TS7Q4TCLJ
36"	48"	TS7Q8TCLJ
36"	54"	TS7Q5TCLJ
36"	66"	TS7Q6TCLJ
42"	48"	TS748TCLJ
42"	54"	TS745TCLJ
42"	66"	TS746TCLJ
42"	78"	TS747TCLJ
48"	54"	TS785TCLJ
48"	66"	TS786TCLJ
48"	78"	TS787TCLJ
54"	66"	TS756TCLJ
54"	78"	TS757TCLJ
66"	78"	TS767TCLJ
.	.	.

Answer T Change-of-Height Junctions—Thin Trim

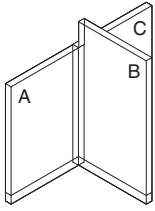

Tip: Junction includes:

- T change-of-height junction
- Inside corner light seal(s)
- T vertical trim
- End-of-run change-of-height trim
- Change-of-height junction cap
- Aligners

Tip: Omit trim option omits all vertical and change-of-height trim. This option is used when stacking on base junctions. Vertical and change-of-height trim should be specified separately to span the full height of the base junction plus the stacking junction.

Tip: Remember to specify necessary junction cap and aligners if the omit trim option is selected.

Standard Includes	Required to Specify
<ul style="list-style-type: none"> ▶ See <i>Answer Solutions Specification Guide</i> for product details. 	<ul style="list-style-type: none"> • Junction • Inside corner light seals • Change-of-height trim and junction cap: paint price group 1 • Aligners
	<ul style="list-style-type: none"> 1 Style number 2 Paint color number for trim 3 Options, if selected (see below) ▶ See <i>Surface Materials</i>, page 480.

Options	Required to Specify
Surface Materials	
Trim <ul style="list-style-type: none"> • Paint price group 1 • Paint price group 2 	Specify paint color number. Specify paint color number.
<ul style="list-style-type: none"> • Omit trim 	Specify <i>with omit trim</i> .

Specification Information			
Corresponding Panel Height			Style Number
A	B	C	
30"	36"	30"	TS73Q3TCTJ
30"	42"	30"	TS7343TCTJ
30"	48"	30"	TS7383TCTJ
30"	54"	30"	TS7353TCTJ
30"	66"	30"	TS7363TCTJ
36"	42"	36"	TS7Q4QTCTJ
36"	48"	36"	TS7Q8QTCTJ
36"	54"	36"	TS7Q5QTCTJ
36"	66"	36"	TS7Q6QTCTJ
42"	48"	42"	TS7484TCTJ
42"	54"	42"	TS7454TCTJ
42"	66"	42"	TS7464TCTJ
42"	78"	42"	TS7474TCTJ
48"	54"	48"	TS7858TCTJ
48"	66"	48"	TS7868TCTJ
48"	78"	48"	TS7878TCTJ
54"	66"	54"	TS7565TCTJ
54"	78"	54"	TS7575TCTJ
66"	78"	66"	TS7676TCTJ

▶ **Specification Information, continued on next page**

► **Specification Information, continued from previous page**

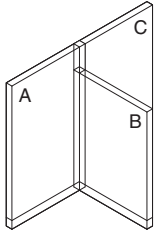

Tip: Junction includes:

- T change-of-height junction
- Inside corner light seals
- T vertical trim
- T change-of-height trim
- 90° junction cap
- Aligners

Specification Information

Corresponding Panel Height			Style Number
A	B	C	
36"	30"	36"	TS7Q3QTCTJ
42"	30"	42"	TS7434TCTJ
48"	30"	48"	TS7838TCTJ
48"	42"	48"	TS7848TCTJ
54"	30"	54"	TS7535TCTJ
66"	30"	66"	TS7636TCTJ
42"	36"	42"	TS74Q4TCTJ
48"	36"	48"	TS78Q8TCTJ
54"	36"	54"	TS75Q5TCTJ
66"	36"	66"	TS76Q6TCTJ
54"	42"	54"	TS7545TCTJ
54"	48"	54"	TS7585TCTJ
66"	42"	66"	TS7646TCTJ
78"	42"	78"	TS7747TCTJ
66"	48"	66"	TS7686TCTJ
78"	48"	78"	TS7787TCTJ
66"	54"	66"	TS7656TCTJ
78"	54"	78"	TS7757TCTJ
78"	66"	78"	TS7767TCTJ

► **Specification Information, continued on next page**

► **Specification Information, continued from previous page**

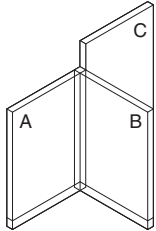

Tip: Junction includes:

- T change-of-height junction
- Inside corner light seals
- T vertical trim
- End-of-run change-of-height trim
- Change-of-height junction cap
- Aligners

Tip: When A and C are different heights, the junction is shipped right-handed. For a left-handed junction a post will need to be moved during installation.

Specification Information

Corresponding Panel Height			Style Number
A	B	C	
30"	30"	36"	TS733QTCTJ
30"	30"	42"	TS7334TCTJ
30"	30"	48"	TS7338TCTJ
30"	30"	54"	TS7335TCTJ
30"	30"	66"	TS7336TCTJ
36"	36"	42"	TS7QQ4TCTJ
36"	36"	48"	TS7QQ8TCTJ
36"	36"	54"	TS7QQ5TCTJ
36"	36"	66"	TS7QQ6TCTJ
42"	42"	48"	TS7448TCTJ
42"	42"	54"	TS7445TCTJ
42"	42"	66"	TS7446TCTJ
42"	42"	78"	TS7447TCTJ
48"	48"	54"	TS7885TCTJ
48"	48"	66"	TS7886TCTJ
48"	48"	78"	TS7887TCTJ
54"	54"	66"	TS7556TCTJ
54"	54"	78"	TS7557TCTJ
66"	66"	78"	TS7667TCTJ

► **Specification Information, continued on next page**

► **Specification Information, continued from previous page**

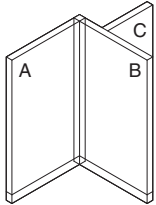

Tip: Junction includes:

- T change-of-height junction
- Inside corner light seals
- T vertical trim
- L change-of-height trim
- 90° junction cap
- Aligners

Tip: When A and C are different heights, the junction is shipped right-handed. For a left-handed junction a post will need to be moved during installation.

Specification Information			
Corresponding Panel Height			Style Number
A	B	C	
36"	36"	30"	TS7QQ3TCTJ
42"	42"	30"	TS7443TCTJ
42"	42"	36"	TS744QTCTJ
48"	48"	36"	TS788QTCTJ
48"	48"	42"	TS7884TCTJ
54"	54"	36"	TS755QTCTJ
66"	66"	36"	TS766QTCTJ
48"	48"	30"	TS7883TCTJ
54"	54"	30"	TS7553TCTJ
66"	66"	30"	TS7663TCTJ
54"	54"	42"	TS7554TCTJ
54"	54"	48"	TS7558TCTJ
66"	66"	42"	TS7664TCTJ
78"	78"	42"	TS7774TCTJ
66"	66"	48"	TS7668TCTJ
78"	78"	48"	TS7778TCTJ
66"	66"	54"	TS7665TCTJ
78"	78"	54"	TS7775TCTJ
78"	78"	66"	TS7776TCTJ

Answer X Change-of-Height Junctions—Thin Trim

Standard Includes		Required to Specify
<ul style="list-style-type: none"> ▶ See <i>Answer Solutions Specification Guide</i> for product details. 	<ul style="list-style-type: none"> • Junction • Inside corner light seals • Trim/junction cap: paint price group 1 • Aligners 	<ul style="list-style-type: none"> 1 Style number 2 Paint color number for junction cap 3 Options, if selected (see below) ▶ See <i>Surface Materials</i>, page 480.

Options		Required to Specify
Surface Materials	Trim <ul style="list-style-type: none"> • Paint price group 1 • Paint price group 2 	Specify paint color number. Specify paint color number.
	<ul style="list-style-type: none"> • Omit trim 	Specify <i>with omit trim</i> .

Tip: Omit trim option omits all change-of-height trim. This option is used when stacking on base junctions. Change-of-height trim should be specified separately to span the full height of the base junction plus stacking junction.

Tip: Remember to specify necessary junction cap and aligners if the omit trim option is selected.

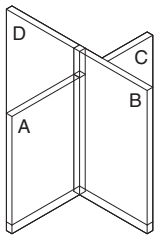

Tip: Junction includes:

- X change-of-height junction
- Two T change-of-height trims
- 90° junction cap
- Aligners

Specification Information				
Corresponding Panel Height				Style Number
A	B	C	D	
30"	36"	30"	36"	TS73Q3QTCXJ
30"	42"	30"	42"	TS73434TCXJ
30"	48"	30"	48"	TS73838TCXJ
30"	54"	30"	54"	TS73535TCXJ
30"	66"	30"	66"	TS73636TCXJ
36"	42"	36"	42"	TS7Q4Q4TCXJ
36"	48"	36"	48"	TS7Q8Q8TCXJ
36"	54"	36"	54"	TS7Q5Q5TCXJ
36"	66"	36"	66"	TS7Q6Q6TCXJ
42"	48"	42"	48"	TS74848TCXJ
42"	54"	42"	54"	TS74545TCXJ
42"	66"	42"	66"	TS74646TCXJ
42"	78"	42"	78"	TS74747TCXJ
48"	54"	48"	54"	TS78585TCXJ
48"	66"	48"	66"	TS78686TCXJ
48"	78"	48"	78"	TS78787TCXJ
54"	66"	54"	66"	TS75656TCXJ
54"	78"	54"	78"	TS75757TCXJ
66"	78"	66"	78"	TS76767TCXJ

▶ **Specification Information, continued on next page**

► **Specification Information, continued from previous page**

Specification Information				
Corresponding Panel Height				Style Number
A	B	C	D	
30"	30"	36"	36"	TS733QQTTCXJ
30"	30"	42"	42"	TS73344TCXJ
30"	30"	48"	48"	TS73388TCXJ
30"	30"	54"	54"	TS73355TCXJ
30"	30"	66"	66"	TS73366TCXJ
36"	36"	42"	42"	TS7QQ44TCXJ
36"	36"	48"	48"	TS7QQ88TCXJ
36"	36"	54"	54"	TS7QQ55TCXJ
36"	36"	66"	66"	TS7QQ66TCXJ
42"	42"	48"	48"	TS74488TCXJ
42"	42"	54"	54"	TS74455TCXJ
42"	42"	66"	66"	TS74466TCXJ
42"	42"	78"	78"	TS74477TCXJ
48"	48"	54"	54"	TS78855TCXJ
48"	48"	66"	66"	TS78866TCXJ
48"	48"	78"	78"	TS78877TCXJ
54"	54"	66"	66"	TS75566TCXJ
54"	54"	78"	78"	TS75577TCXJ
66"	66"	78"	78"	TS76677TCXJ

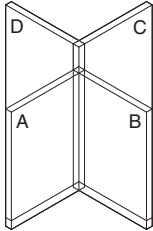

Tip: Junction includes:

- X change-of-height junction
- Inside corner light seals
- L change-of-height trim
- 90° junction cap
- Aligners

► **Specification Information, continued on next page**

► **Specification Information, continued from previous page**

Specification Information				
Corresponding Panel Height				Style Number
A	B	C	D	
30"	30"	30"	36"	TS7333QTCXJ
30"	30"	30"	42"	TS73334TCXJ
30"	30"	30"	48"	TS73338TCXJ
30"	30"	30"	54"	TS73335TCXJ
30"	30"	30"	66"	TS73336TCXJ
36"	36"	36"	42"	TS7QQQ4TCXJ
36"	36"	36"	48"	TS7QQQ8TCXJ
36"	36"	36"	54"	TS7QQQ5TCXJ
36"	36"	36"	66"	TS7QQQ6TCXJ
42"	42"	42"	48"	TS74448TCXJ
42"	42"	42"	54"	TS74445TCXJ
42"	42"	42"	66"	TS74446TCXJ
42"	42"	42"	78"	TS74447TCXJ
48"	48"	48"	54"	TS78885TCXJ
48"	48"	48"	66"	TS78886TCXJ
48"	48"	48"	78"	TS78887TCXJ
54"	54"	54"	66"	TS75556TCXJ
54"	54"	54"	78"	TS75557TCXJ
66"	66"	66"	78"	TS76667TCXJ

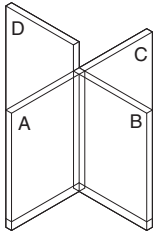

- Tip: Junction includes:**
- X change-of-height junction
 - Inside corner light seals
 - End-of-run change-of-height trim
 - Change-of-height junction cap
 - Aligners

► **Specification Information, continued on next page**

► Specification Information, continued from previous page

Specification Information				
Corresponding Panel Height				Style Number
A	B	C	D	
36"	36"	36"	30"	TS7QQQ3TCXJ
42"	42"	42"	30"	TS74443TCXJ
42"	42"	42"	36"	TS7444QTCXJ
48"	48"	48"	36"	TS7888QTCXJ
54"	54"	54"	36"	TS7555QTCXJ
66"	66"	66"	36"	TS7666QTCXJ
48"	48"	48"	30"	TS78883TCXJ
48"	48"	48"	42"	TS78884TCXJ
54"	54"	54"	30"	TS75553TCXJ
54"	54"	54"	42"	TS75554TCXJ
54"	54"	54"	48"	TS75558TCXJ
66"	66"	66"	30"	TS76663TCXJ
66"	66"	66"	42"	TS76664TCXJ
66"	66"	66"	48"	TS76668TCXJ
66"	66"	66"	54"	TS76665TCXJ
78"	78"	78"	42"	TS77774TCXJ
78"	78"	78"	48"	TS77778TCXJ
78"	78"	78"	54"	TS77775TCXJ
78"	78"	78"	66"	TS77776TCXJ

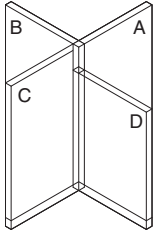

Tip: Junction includes:

- X change-of-height junction
- Inside corner light seals
- T change-of-height trim
- 90° junction cap
- Aligners

Answer V Change-of-Height Junctions—Thin Trim

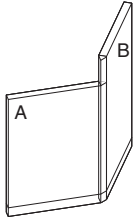

Tip: Junction includes:

- V change-of-height junction
- V vertical trim
- 120° change-of-height trim
- 120° junction cap
- Aligner

Tip: Omit trim option omits all vertical and change-of-height trim. This option is used when stacking on base junctions. Vertical and change-of-height trim should be specified separately to span the full height of the base junction plus stacking junction.

Tip: Remember to specify necessary junction caps and aligners if the omit trim option is selected.

Tip: Change-of-height junction ships right-handed. For a left-handed junction, a post will need to be moved during installation.

Standard Includes		Required to Specify
▶ See <i>Answer Solutions Specification Guide</i> for product details.	<ul style="list-style-type: none"> • Junction • Change-of-height trim and junction cap: paint price group 1 • Aligners 	1 Style number 2 Paint color number for trim 3 Options, if selected (see below) ▶ See <i>Surface Materials</i> , page 480.

Options		Required to Specify
Surface Materials	Trim	
	<ul style="list-style-type: none"> • Paint price group 1 • Paint price group 2 	Specify paint color number. Specify paint color number.
	<ul style="list-style-type: none"> • Omit trim 	Specify <i>with omit trim</i> .

Specification Information		
Corresponding Panel Height		Style Number
A	B	
30"	36"	TS73QTCVJ
30"	42"	TS734TCVJ
30"	48"	TS738TCVJ
30"	54"	TS735TCVJ
30"	66"	TS736TCVJ
36"	42"	TS7Q4TCVJ
36"	48"	TS7Q8TCVJ
36"	54"	TS7Q5TCVJ
36"	66"	TS7Q6TCVJ
42"	48"	TS748TCVJ
42"	54"	TS745TCVJ
42"	66"	TS746TCVJ
42"	78"	TS747TCVJ
48"	54"	TS785TCVJ
48"	66"	TS786TCVJ
48"	78"	TS787TCVJ
54"	66"	TS756TCVJ
54"	78"	TS757TCVJ
66"	78"	TS767TCVJ

Answer Y Change-of-Height Junctions—Thin Trim

Standard Includes		Required to Specify
<ul style="list-style-type: none"> ▶ See <i>Answer Solutions Specification Guide</i> for product details. 	<ul style="list-style-type: none"> • Junction • Change-of-height trim and junction cap: paint price group 1 • Aligners 	<ul style="list-style-type: none"> 1 Style number 2 Paint color number for trim 3 Options, if selected (see below) ▶ See <i>Surface Materials</i>, page 480.

Options	Required to Specify
Surface Materials <ul style="list-style-type: none"> • Trim • Paint price group 1 • Paint price group 2 	<ul style="list-style-type: none"> Specify paint color number. Specify paint color number.
<ul style="list-style-type: none"> • Omit trim 	<ul style="list-style-type: none"> Specify <i>with omit trim</i>.

Tip: Omit trim option omits all change-of-height trim. This option is used when stacking on base junctions. Change-of-height trim should be specified separately to span the full height of the base junction plus stacking junction.

Tip: Remember to specify necessary junction caps and aligners if the omit trim option is selected.

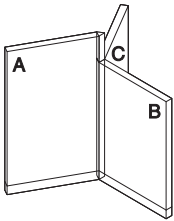

Tip: Junction includes:

- Y change-of-height junction
- 120° change-of-height trim
- 120° junction cap

Specification Information			
Corresponding Panel Height			Style Number
A	B	C	
36"	30"	30"	TS7Q33TCYJ
42"	30"	30"	TS7433TCYJ
42"	36"	36"	TS74QQTCYJ
48"	36"	36"	TS78QQTCYJ
54"	36"	36"	TS75QQTCYJ
66"	36"	36"	TS76QQTCYJ
48"	30"	30"	TS7833TCYJ
48"	42"	42"	TS7844TCYJ
54"	30"	30"	TS7533TCYJ
54"	48"	48"	TS7588TCYJ
66"	30"	30"	TS7633TCYJ
54"	42"	42"	TS7544TCYJ
66"	42"	42"	TS7644TCYJ
78"	42"	42"	TS7744TCYJ
66"	48"	48"	TS7688TCYJ
78"	48"	48"	TS7788TCYJ
66"	54"	54"	TS7655TCYJ
78"	54"	54"	TS7755TCYJ
78"	66"	66"	TS7766TCYJ

▶ **Specification Information, continued on next page**

► Specification Information, continued from previous page

Specification Information			
Corresponding Panel Height			Style Number
A	B	C	
30"	36"	36"	TS73QQTCYJ
30"	42"	42"	TS7344TCYJ
30"	48"	48"	TS7388TCYJ
30"	54"	54"	TS7355TCYJ
30"	66"	66"	TS7366TCYJ
36"	42"	42"	TS7Q44TCYJ
36"	48"	48"	TS7Q88TCYJ
36"	54"	54"	TS7Q55TCYJ
36"	66"	66"	TS7Q66TCYJ
42"	48"	48"	TS7488TCYJ
42"	54"	54"	TS7455TCYJ
42"	66"	66"	TS7466TCYJ
42"	78"	78"	TS7477TCYJ
48"	54"	54"	TS7855TCYJ
48"	66"	66"	TS7866TCYJ
48"	78"	78"	TS7877TCYJ
54"	66"	66"	TS7566TCYJ
54"	78"	78"	TS7577TCYJ
66"	78"	78"	TS7677TCYJ

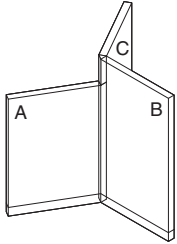

- Tip: Junction includes:**
- Y change-of-height junction
 - V change-of-height trim
 - 120° junction cap
 - Aligner

Answer Wall-Start Junctions



Tip: When using in an off-module application, off-module panel connector must be ordered separately.
 ▶ See Answer Solutions Specification Guide.

Standard Includes	Required to Specify
▶ See Answer Solutions Specification Guide for product details.	Style number

Specification Information	
• Height	• Style Number
36"	TS736WPJ
42"	TS742WPJ
48"	TS748WPJ
54"	TS754WPJ
66"	TS766WPJ
78"	TS778WPJ
:	:

Answer Off-Module Panel Connectors

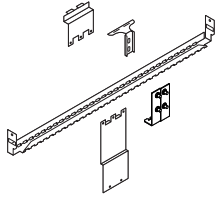

Tip: Must be used with wall-start junctions, ordered separately.

Tip: Off-module panel connector works with thin, square, and oval style trims. Top cap filler included in package is only used with oval style trims. Thin and square style trims do not require a top cap filler.

Tip: Wall-start junctions manufactured before October 2002 will not work with off-module panel connectors.

Tip: When using with wall-start junction manufactured before October 10, 2011, the bottom bracket must be replaced with part number T500938MP from service parts.

Standard Includes	Required to Specify
<ul style="list-style-type: none"> ▶ See <i>Answer Solutions Specification Guide</i> for product details. • Top and bottom bracket • Bottom channel • Top cap filler (oval style): plastic 	<ul style="list-style-type: none"> 1 Style number 2 Plastic color number for filler ▶ See <i>Surface Materials</i>, page 480.

Specification Information

Width	Style Number
24"	TS724BKT
30"	TS730BKT
36"	TS736BKT
42"	TS742BKT
48"	TS748BKT
60"	TS760BKT
72"	TS772BKT
:	:

Answer Stacking Junctions

Stacking In-Line Panel Junctions—Thin Trim



Tip: Stacking in-line junctions do not require junction cap and trim.

Standard Includes		Required to Specify
<ul style="list-style-type: none"> ▶ See <i>Answer Solutions Specification Guide</i> for product details. 	<ul style="list-style-type: none"> • Junction • Fork connectors 	Style number
Specification Information		
• Height	• Style	• Number
12"	TS712IPJS	
18"	TS718IPJS	
24"	TS724IPJS	
:	:	:

Stacking End-of-Run Panel Junctions—Thin Trim



Tip: Stacking end-of-run junctions do not include trim. Trim is specified separately to span entire height of base junction plus stacking junction.

Tip: 36" stacker is only used in build your own change-of-height applications. It should never be used as an end-of-run stacking junction.

Standard Includes		Required to Specify
<ul style="list-style-type: none"> ▶ See <i>Answer Solutions Specification Guide</i> for product details. 	<ul style="list-style-type: none"> • Junction • Fork connector 	Style number
Specification Information		
• Height	• Style	• Number
12"	TS712TEPJS	
18"	TS718TEPJS	
24"	TS724TEPJS	
36"	TS736TEPJS	
:	:	:

Stacking Wall-Start Junctions



Standard Includes	Required to Specify
<ul style="list-style-type: none"> ▶ See <i>Answer Solutions Specification Guide</i> for product details. 	<ul style="list-style-type: none"> • Junction • Fork connector
	Style number

Specification Information	
• Height	• Style Number
12"	TS712WPJS
18"	TS718WPJS
24"	TS724WPJS
.	.

Answer Stacking L, T, X, V, and Y Panel Junctions—Thin Trim

Tip: Stacking corner junctions do not include trim. Trim is specified separately to span entire height of base junction plus stacking junction.

Tip: Junction cap is not included and must be specified separately.



Standard Includes		Required to Specify
<ul style="list-style-type: none"> See Answer Solutions Specification Guide for product details. 	<ul style="list-style-type: none"> Junction Fork connectors 	Style number

Specification Information	
• Height	• Style Number
:	:
:	:

L Panel Junctions	
12"	TS712TLPJS
18"	TS718TLPJS
24"	TS724TLPJS
:	:

T Panel Junctions	
12"	TS712TTPJS
18"	TS718TTPJS
24"	TS724TTPJS
:	:

X Panel Junctions	
12"	TS712XPJS
18"	TS718XPJS
24"	TS724XPJS
:	:

V Panel Junctions	
12"	TS712TVPJS
18"	TS718TVPJS
24"	TS724TVPJS
:	:

Y Panel Junctions	
12"	TS712YPJS
18"	TS718YPJS
24"	TS724YPJS
:	:

Answer Utility Pole – L, T, and X—Thin Trim

Answer Utility Pole – L, T,
and X—Thin Trim



Tip: Works with L, T, or X base junctions of any height and T or X change-of-height junctions as long as at least two panels are at the tallest height.

Tip: For end-of-run utility pole application, the square trim junction utility pole may be used.

Note: this will add 3" of dimension to the application.

▶ See Answer Solutions Specification Guide

Tip: Cannot be used with L change-of-height junctions.

Tip: Can only be used with junctions manufactured on or after October 10, 2011.

Tip: Does not include junction. Junction is ordered separately.

Tip: Order multipurpose power infeed separately.

Standard Includes		Required to Specify
▶ See Answer Solutions Specification Guide for product details.	<ul style="list-style-type: none"> Utility pole: paint price group 1 Ceiling trim plate: white paint only Mounting brackets 	1 Style number 2 Paint color number for utility pole 3 Options, if selected (see below) ▶ See Surface Materials, page 480.

Options		Required to Specify
Surface	<ul style="list-style-type: none"> Paint price group 1 	Specify paint color number.
Materials	<ul style="list-style-type: none"> Paint price group 2 	Specify paint color number.

Specification Information	
Configuration	Style Number
L, T, or X junctions	TS7TJUP

Answer Utility Packages

Ceiling-Access Lay-In Utility Packages—Thin Trim

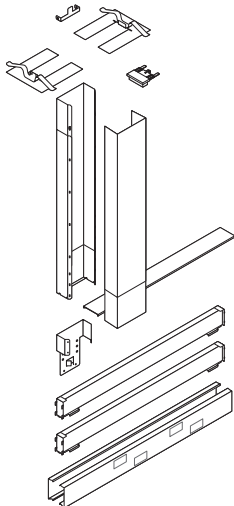

Tip: Order multipurpose power infeed separately.

Standard Includes	Required to Specify
<ul style="list-style-type: none"> ▶ See <i>Answer Solutions Specification Guide</i> for product details. • Utility carrier and cover, one top cap, and two standard base trims: paint price group 1 • Two lay-in horizontal connecting bars: black paint only • Ceiling attachment hardware • Junction cap for end-of-run applications: paint 	<ul style="list-style-type: none"> 1 Style number 2 Paint color number for utility carrier and cover, top cap, base trim, and junction cap 3 Options, if selected (see below) ▶ See <i>Surface Materials</i>, page 480.

Options	Required to Specify
Surface Materials <ul style="list-style-type: none"> • Paint price group 1 • Paint price group 2 	Specify paint color number. Specify paint color number.
Change-of-Height Top Cap <ul style="list-style-type: none"> • Change-of-height at one end of top cap, slim • Change-of-height at one end of top cap, cable management 	Specify <i>with change-of-height, one end slim</i> . Specify <i>with change-of-height, one end cable management</i> .
Base Cable Tray <ul style="list-style-type: none"> • Base cable tray 	Specify <i>with base cable tray</i> .

Specification Information	
Width	Style Number
30"	TS730TSUC
36"	TS736TSUC
42"	TS742TSUC
48"	TS748TSUC
:	:

Floor-Access Lay-In Utility Packages—Thin Trim

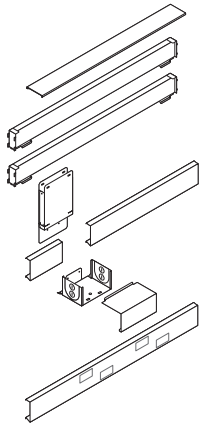

Tip: 30"W lay-in utility package with floor-access is only available with change-of-height top cap at one end.

Tip: Order multipurpose power infeed separately.

Standard Includes	Required to Specify
<ul style="list-style-type: none"> ▶ See <i>Answer Solutions Specification Guide</i> for product details. • One top cap, one standard base trim, one modified base trim, and one base utility box: paint price group 1 • Two lay-in horizontal connecting bars: black paint only 	<ul style="list-style-type: none"> 1 Style number 2 Paint color number for top cap, base trim, and base utility box 3 Options, if selected (see below) ▶ See <i>Surface Materials</i>, page 480.

Options	Required to Specify
<p>Surface Materials</p> <ul style="list-style-type: none"> • Paint price group 1 • Paint price group 2 	<ul style="list-style-type: none"> Specify paint color number. Specify paint color number.
<p>Change-of-Height Top Cap</p> <ul style="list-style-type: none"> • Change-of-height at one end of top cap, slim cable management • Change-of-height at one end of top cap, cable management • Change-of-height at both ends of top cap on 36" - 48"W packages, slim • Change-of-height at both ends of top cap on 36" - 48"W packages, cable management • Change-of-height at both ends of top cap on 36" - 48"W packages, 1 end slim and one end cable management 	<ul style="list-style-type: none"> Specify with <i>change-of-height, one end slim</i>. Specify with <i>change-of-height, one end cable management</i>. Specify with <i>change-of-height, both ends slim</i>. Specify with <i>change-of-height, both ends cable management</i>. Specify with <i>change-of-height, one end slim, one end cable management</i>.

Specification Information	
Width	Style Number
30"	TS730TSUF
36"	TS736TSUF
42"	TS742TSUF
48"	TS748TSUF
⋮	⋮

Answer End-of-Run Vertical Trims—Thin Trim



Tip: When ordering vertical trim for a stacking application remember to specify it to span the full height of the base junction plus the stacking junction.

Tip: Thin vertical trim cannot be mixed with square and oval trim on an application. Thin trim must be used on the entire application.

Standard Includes		Required to Specify
▶ See <i>Answer Solutions Specification Guide</i> for product details.	<ul style="list-style-type: none"> Trim: paint price group 1 Aligner 	1 Style number 2 Paint color number for trim 3 Options, if selected (see below) ▶ See <i>Surface Materials</i> , page 480.

Options		Required to Specify
Surface Materials	<ul style="list-style-type: none"> Paint price group 1 Paint price group 2 	Specify paint color number. Specify paint color number.

Specification Information	
• Corresponding Panel Height	• Style Number
:	:
:	:

Painted Trim	
30"	TS730TEVT
36"	TS736TEVT
42"	TS742TEVT
48"	TS748TEVT
54"	TS754TEVT
60"	TS760TEVT
66"	TS766TEVT
72"	TS772TEVT
78"	TS778TEVT
84"	TS784TEVT
90"	TS790TEVT
:	:

Answer L and T Vertical Trims—Thin Trim

Answer L and T Vertical Trims—Thin Trim

Tip: When ordering vertical trim for a stacking application remember to specify it to span the full height of the base junction plus the stacking junction.

Tip: Thin vertical trim cannot be mixed with square or oval trim on an application. Thin trim must be used on the entire application.



Standard Includes		Required to Specify
<ul style="list-style-type: none"> ▶ See <i>Answer Solutions Specification Guide</i> for product details. 	<ul style="list-style-type: none"> • Trim: paint price group 1 	<ul style="list-style-type: none"> 1 Style number 2 Paint color number for trim 3 Options, if selected (see below) ▶ See <i>Surface Materials</i>, page 480.

Options		Required to Specify
Surface Materials	<ul style="list-style-type: none"> • Paint price group 1 • Paint price group 2 	<ul style="list-style-type: none"> Specify paint color number. Specify paint color number.

Specification Information	
• Corresponding Panel Height	• Style Number
:	:
:	:

Painted L Vertical Trim

30"	TS730TLVT
36"	TS736TLVT
42"	TS742TLVT
48"	TS748TLVT
54"	TS754TLVT
60"	TS760TLVT
66"	TS766TLVT
72"	TS772TLVT
78"	TS778TLVT
84"	TS784TLVT
90"	TS790TLVT
:	:

Painted T Vertical Trim

30"	TS730TTVT
36"	TS736TTVT
42"	TS742TTVT
48"	TS748TTVT
54"	TS754TTVT
60"	TS760TTVT
66"	TS766TTVT
72"	TS772TTVT
78"	TS778TTVT
84"	TS784TTVT
90"	TS790TTVT
:	:

Answer V Vertical Trims—Thin Trim



Tip: When ordering vertical trim for a stacking application remember to specify it to span the full height of the base junction plus the stacking junction.

Tip: Thin vertical trim cannot be mixed with square and oval trim on an application. Thin trim must be used on the entire application.

Standard Includes	Required to Specify
<ul style="list-style-type: none"> ▶ See <i>Answer Solutions Specification Guide</i> for product details. • Trim: paint price group 1 	<ul style="list-style-type: none"> 1 Style number 2 Paint color number for trim 3 Options, if selected (see below) ▶ See <i>Surface Materials</i>, page 480.

Options	Required to Specify
Surface Materials <ul style="list-style-type: none"> • Paint price group 1 • Paint price group 2 	<ul style="list-style-type: none"> Specify paint color number. Specify paint color number.

Specification Information	
• Corresponding Panel Height	• Style Number
•	•
•	•
•	•

Painted Trim	
30"	TS730TVVT
36"	TS736TVVT
42"	TS742TVVT
48"	TS748TVVT
54"	TS754TVVT
60"	TS760TVVT
66"	TS766TVVT
72"	TS772TVVT
78"	TS778TVVT
84"	TS784TVVT
90"	TS790TVVT
•	•
•	•

Answer End-of-Run/In-Line Change-of-Height Trims—Thin Trim

Answer End-of-Run/In-Line
Change-of-Height
Trims—Thin Trim



Tip: Thin change-of-height trim cannot be used with square or oval top trim.

Standard Includes	Required to Specify
<ul style="list-style-type: none"> ▶ See <i>Answer Solutions Specification Guide</i> for product details. • Trim: paint price group 1 • Aligner 	<ul style="list-style-type: none"> 1 Style number 2 Paint color number for trim 3 Options, if selected (see below) ▶ See <i>Surface Materials</i>, page 480.

Options	Required to Specify
Surface Materials <ul style="list-style-type: none"> • Paint price group 1 • Paint price group 2 	<ul style="list-style-type: none"> Specify paint color number. Specify paint color number.

Specification Information	
• Corresponding Panel Height	• Style Number
•	•
•	•

Painted Trim	
6"	TS76TICHT
12"	TS712TICHT
18"	TS718TICHT
24"	TS724TICHT
30"	TS730TICHT
36"	TS736TICHT
•	•

Answer 90° Corner Application Change-of-Height Trims—Thin Trim

Tip: Thin change-of-height trim cannot be used with square or oval top trim.

	Standard Includes	Required to Specify
▶ See <i>Answer Solutions Specification Guide</i> for product details.	<ul style="list-style-type: none"> Trim: paint price group 1 	<ul style="list-style-type: none"> 1 Style number 2 Paint color number for trim 3 Options, if selected (see below) ▶ See <i>Surface Materials</i>, page 480.

	Options	Required to Specify
Surface Materials	<ul style="list-style-type: none"> Paint price group 1 Paint price group 2 	<ul style="list-style-type: none"> Specify paint color number. Specify paint color number.

Specification Information	
• Corresponding Panel Height	• Style Number
•	•
•	•
•	•

Painted Trim

L Corner Change-of-Height Trim

6"	TS76TCLCHT
12"	TS712TCLCHT
18"	TS718TCLCHT
24"	TS724TCLCHT
30"	TS730TCLCHT
36"	TS736TCLCHT

T Corner Change-of-Height Trim

6"	TS76TCTCHT
12"	TS712TCTCHT
18"	TS718TCTCHT
24"	TS724TCTCHT
30"	TS730TCTCHT
36"	TS736TCTCHT
•	•



Answer 120° Corner Application Change-of-Height Trims—Thin Trim

Answer 120°
Corner Application
Change-of-Height
Trims—Thin Trim

Tip: Thin change-of-height trim cannot be used with square or oval top trim.

Standard Includes	Required to Specify
<ul style="list-style-type: none"> ▶ See <i>Answer Solutions Specification Guide</i> for product details. • Trim: paint price group 1 	<ul style="list-style-type: none"> 1 Style number 2 Paint or wood color number for trim 3 Options, if selected (see below) ▶ See <i>Surface Materials</i>, page 480.

Options	Required to Specify
Surface Materials <ul style="list-style-type: none"> • Paint price group 1 • Paint price group 2 	<ul style="list-style-type: none"> Specify paint color number. Specify paint color number.

Specification Information	
• Corresponding Panel Height	• Style Number
•	•
•	•
•	•

Painted Trim

120° Corner Change-of-Height Trim

6"	TS76T120CHT
12"	TS712T120CHT
18"	TS718T120CHT
24"	TS724T120CHT
30"	TS730T120CHT
36"	TS736T120CHT

V Corner Change-of-Height Trim

6"	TS76TVCHT
12"	TS712TVCHT
18"	TS718TVCHT
24"	TS724TVCHT
30"	TS730TVCHT
36"	TS736TVCHT
•	•



Answer Build Your Own Junction Components—Thin Trim

Junction Posts



Tip: Junction post can be used at an end-of-run configuration or to change a junction application between an L, T, X, V, or Y.

Tip: Junction block to post fasteners are included with junction blocks. For additional fasteners order part number T521882MP (quantity 50).

Standard Includes	Required to Specify
<ul style="list-style-type: none"> See Answer Solutions Specification Guide for product details. Junction post 	Style number

Specification Information

Height	Style Number
30"	TS730JP
36"	TS736JP
42"	TS742JP
48"	TS748JP
54"	TS754JP
66"	TS766JP
78"	TS778JP
:	:

Junction Blocks

Tip: When determining the number of junction blocks needed in a same-height corner, start with your lowest panel height. If the lowest height is 48" or less, start with 2 blocks. If the lowest height is 54" to 78" start with 3 blocks.

Tip: When determining the number of blocks needed in a change-of-height corner, please see Answer Solutions Specification Guide, How to Build Your Own Change-of-Height Applications.



Standard Includes	Required to Specify
<ul style="list-style-type: none"> See Answer Solutions Specification Guide for product details. Junction blocks Fasteners 	Style number

Specification Information

Application	Package Quantity	Style Number
90°	3	TS790JB3
90°	4	TS790JB4
90°	5	TS790JB5
120°	3	TS7120JB3
120°	4	TS7120JB4
120°	5	TS7120JB5
:	:	:

Inside Corner Light Seals



Tip: Inside corner light seals can be field cut for use on shorter panels.

Standard Includes		Required to Specify
<ul style="list-style-type: none"> ▶ See <i>Answer Solutions Specification Guide</i> for product details. 	<ul style="list-style-type: none"> • Inside corner light seal, package of four: black plastic 	Style number
Specification Information		
Height	Style Number	
54"	TS754ICLS	
66"	TS766ICLS	
78"	TS778ICLS	

Junction Caps

Tip: Aligners are specified separately.

Tip: 90° corner and 90° change-of-height corner junction cap include no aligners. All are specified separately.

Tip: 120° corner junction cap includes one integral aligner. Additional aligners are specified separately.



Standard Includes		Required to Specify
<ul style="list-style-type: none"> ▶ See <i>Answer Solutions Specification Guide</i> for product details. 	<ul style="list-style-type: none"> • Junction cap: paint 	1 Style number 2 Paint color number for junction cap 3 Options, if selected (see below) ▶ See <i>Surface Materials</i> , page 480.
Options		Required to Specify
Surface Materials	<ul style="list-style-type: none"> • Paint price group 1 • Paint price group 2 	Specify paint color number. Specify paint color number.
Specification Information		
Corresponding Panel Application	Style Number	
Painted Junction Cap		
90° corner	TS790JC	
120° corner	TS7120JC	
90° change-of-height corner	TS790COHJC	

Junction Cap and Trim Aligners

Standard Includes	Required to Specify
<ul style="list-style-type: none"> See <i>Answer Solutions Specification Guide</i> for product details. 	<ul style="list-style-type: none"> Junction cap aligner or vertical trim aligner
	Style number

Specification Information

Description	Package Quantity	Style Number
-------------	------------------	--------------

Junction Cap Aligner

Corner aligner	10	TS7CJCA10
----------------	----	------------------

Vertical Trim Aligners

L to T aligner	4	TS7LTA4
----------------	---	----------------

120° to V aligner	4	TS7120VA4
⋮	⋮	⋮



Answer Base Horizontal Frame Packages— Thin Trim and Big Open Base Trim Package

For Panel Buildups

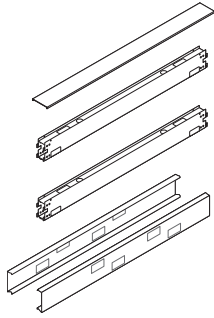

Tip: You must order vertical junctions separately to complete your frame.

Tip: Specify omit top cap when adding a frameless glass screen to a panel or when ordering spanning top caps.

Tip: Change-of-height top caps are only required in an in-line change-of-height application.

Tip: Remember to omit base trim(s) when using skins to the floor.

Tip: Omit base trim and separately specify hardwire base trims when accessing hardwire power in the base.

Tip: When open base trim or big open base option is selected, both base trims are omitted.

Tip: Base cable tray cannot be used if open base or big open base is selected, or if omit base trim is selected for one or both sides of panel.

Tip: Remember to order skins to complete the panel.

Standard Includes	Required to Specify
<ul style="list-style-type: none"> ▶ See <i>Answer Solutions Specification Guide</i> for product details. Standard length top cap: color default determined by base trim paint color Base trim with no knockouts (on 18"W): paint price group 1 Base trim with knockouts (24"W to 72"W): paint price group 1 Two horizontal connecting bars: black paint only 	<ul style="list-style-type: none"> 1 Style number 2 Paint color number for trim 3 Options, if selected (see below) ▶ See <i>Surface Materials</i>, page 480.

Options	Required to Specify
<p>Surface Materials</p> <ul style="list-style-type: none"> Paint price group 1 Paint price group 2 	<ul style="list-style-type: none"> Specify paint color number. Specify paint color number.
<p>Top cap</p> <ul style="list-style-type: none"> Omit top cap 	<ul style="list-style-type: none"> Specify <i>omit top cap</i>.
<p>Change-of-Height Top Cap</p> <ul style="list-style-type: none"> Change-of-height at one end of top cap Change-of-height at both ends of top cap on 36"W and wider packages 	<ul style="list-style-type: none"> Specify <i>with change-of-height, one end</i>. Specify <i>with change-of-height, both ends</i>.
<p>Base Trim</p> <ul style="list-style-type: none"> Knockouts one side, plain one side (24"W to 72"W only) Plain both sides (24"W to 72"W only) Omit one side, knockouts one side, 24"W to 36"W Omit one side, knockouts one side, 42"W to 48"W Omit one side, knockouts one side, 60"W to 72"W Omit one side, plain one side, 18"W to 36"W Omit one side, plain one side, 42"W to 48"W Omit one side, plain one side, 60"W to 72"W Omit both sides, 18"W to 36"W Omit both sides, 42"W to 48"W Omit both sides, 60"W to 72"W 	<ul style="list-style-type: none"> Specify <i>with knockouts one side, plain one side</i>. Specify <i>with plain both sides</i>. Specify <i>with omit one side, knockouts one side</i>. Specify <i>with omit one side, knockouts one side</i>. Specify <i>with omit one side, knockouts one side</i>. Specify <i>with omit one side, plain one side</i>. Specify <i>with omit one side, plain one side</i>. Specify <i>with omit one side, plain one side</i>. Specify <i>with omit both sides</i>. Specify <i>with omit both sides</i>. Specify <i>with omit both sides</i>.
<p>Open Base Trim</p> <ul style="list-style-type: none"> Open base 	<ul style="list-style-type: none"> Specify <i>with open base</i>.
<p>Big Open Base</p> <ul style="list-style-type: none"> Big open base 	<ul style="list-style-type: none"> Specify <i>with big open base</i>.
<p>Cable Tray</p> <ul style="list-style-type: none"> Cable tray 	<ul style="list-style-type: none"> Specify <i>with cable tray</i>.
<p>Base Cable Tray</p> <ul style="list-style-type: none"> Base cable tray 	<ul style="list-style-type: none"> Specify <i>with base cable tray</i>.

Specification Information

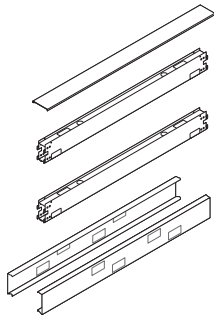

• Height	• Style Number
18"	TS718THF
24"	TS724THF
30"	TS730THF
36"	TS736THF
42"	TS742THF
48"	TS748THF
60"	TS760THF
72"	TS772THF

Answer Stacking Horizontal Frame Packages

For Panel Buildups

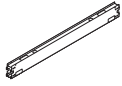

Tip: You must order vertical stacking junctions separately to complete your frame.

Tip: Top cap is not included. Use the top cap from the base panel you are stacking on.

Tip: If stacking a window kit, stacking horizontal frame package is not needed.

Tip: Remember to order skins to complete the panel.

Standard Includes	Required to Specify
<ul style="list-style-type: none"> See <i>Answer Solutions Specification Guide</i> for product details. 	<ul style="list-style-type: none"> One horizontal connecting bar: black paint only Style number

Specification Information

Width	Style Number
18"	TS718HFS
24"	TS724HFS
30"	TS730HFS
36"	TS736HFS
42"	TS742HFS
48"	TS748HFS
60"	TS760HFS
72"	TS772HFS
⋮	⋮

Answer Spanning Top Caps—Thin Trim

For Panel Buildups

Answer Spanning Top Caps—Thin Trim

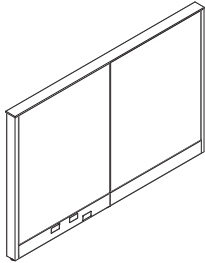

Tip: In-line spanning top cap lightseals should be specified for each in-line joint top cap it is spanning across.

Standard Includes		Required to Specify
<ul style="list-style-type: none"> ▶ See <i>Answer Solutions Specification Guide</i> for product details. 	<ul style="list-style-type: none"> • Top cap: paint 	<ul style="list-style-type: none"> 1 Style number 2 Paint color number for top cap 3 Options, if selected (see below) ▶ See <i>Surface Materials</i>, page 480.

Options		Required to Specify
Change-of-Height Top Cap	<ul style="list-style-type: none"> • Change-of-height at one end of top cap • Change-of-height at both ends of top cap 	<ul style="list-style-type: none"> Specify with <i>change-of-height, one end.</i> Specify with <i>change-of-height, both ends.</i>

Specification Information	
• Width	• Style Number
•	•
•	•
•	•

Painted Top Cap	
36"	TS736TTC
42"	TS742TTC
48"	TS748TTC
54"	TS754TTC
60"	TS760TTC
66"	TS766TTC
72"	TS772TTC
78"	TS778TTC
84"	TS784TTC
90"	TS790TTC
96"	TS796TTC
•	•

Answer Fabric Covered Panel Skins

For Panel Buildups

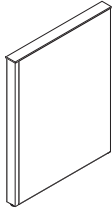

Tip: 72"W fabric-covered panel skins accommodate fabric in the horizontal direction only.

Tip: For further information about fabric direction, see Answer Solutions Specification Guide.

Tip: 18"H, 30"H, and 42"H skins only work on junctions manufactured on or after October 10, 2011.

Standard Includes	Required to Specify
<ul style="list-style-type: none"> See <i>Answer Solutions Specification Guide</i> for product details. Tackable acoustical panel skin, fabric direction with horizontal application, if selected: fabric price group 1 Performance tackable acoustical panel skin, fabric direction with horizontal application, if selected: fabric price group 1 	<ul style="list-style-type: none"> 1 Style number 2 Paint color number for skin surface. 3 Options, if selected (see below) ▶ See <i>Surface Materials</i>, page 480.

Options	Required to Specify
Surface Materials <ul style="list-style-type: none"> Fabric price group A Fabric price group 1 Fabric price group 2 Fabric price group 3 	<ul style="list-style-type: none"> Specify fabric color number. Specify fabric color number. Specify fabric color number.
Fabric direction on 18"W to 60"W panels <ul style="list-style-type: none"> Vertical application 	Specify with vertical application.

Specification Information			
12"H	18"H	24"H	30"H
• Width • Style Number	• Style Number	• Style Number	• Style Number

Tackable Acoustical Skins

18"	TS71218TK	TS71818TK	TS72418TK	TS73018TK
24"	TS71224TK	TS71824TK	TS72424TK	TS73024TK
30"	TS71230TK	TS71830TK	TS72430TK	TS73030TK
36"	TS71236TK	TS71836TK	TS72436TK	TS73036TK
42"	TS71242TK	TS71842TK	TS72442TK	TS73042TK
48"	TS71248TK	TS71848TK	TS72448TK	TS73048TK
60"	TS71260TK	TS71860TK	TS72460TK	TS73060TK
72"	TS71272TK	TS71872TK	TS72472TK	TS73072TK

36"H	42"H	48"H	60"H

Tackable Acoustical Skins

18"	TS73618TK	TS74218TK	TS74818TK	TS76018TK
24"	TS73624TK	TS74224TK	TS74824TK	TS76024TK
30"	TS73630TK	TS74230TK	TS74830TK	TS76030TK
36"	TS73636TK	TS74236TK	TS74836TK	TS76036TK
42"	TS73642TK	TS74242TK	TS74842TK	TS76042TK
48"	TS73648TK	TS74248TK	TS74848TK	TS76048TK
60"	TS73660TK	TS74260TK	TS74860TK	TS76060TK
72"	TS73672TK	TS74272TK	TS74872TK	TS76072TK

Answer Fabric Covered Panel Skins To The Floor

For Panel Buildups

Answer Fabric Covered
Panel Skins To The Floor

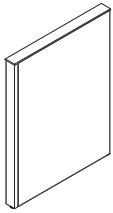

Tip: Remember to omit base trim(s) on a horizontal frame package when using a skin to the floor.

Tip: 48"H fabric covered panel skins to the floor accommodate select fabrics in the vertical direction only.

Tip: 48"H and 60"H fabric covered panel skins accommodate fabric in the vertical direction only.

Tip: 72"W fabric covered panel skins accommodate fabric in the horizontal direction only.

Tip: For further information about fabric direction see Answer Solutions Specification Guide.

Tip: 30"H and 42"H skins only work on junctions manufactured on or after October 10, 2011.

Tip: When specifying skins, the total skin height will be 6" less than the panel height. Skins to the floor are indicated by an F suffix. Plan 6" shorter than panel height, but skins to the floor are taller in actual height to cover the base trim area.

▶ See Panel Buildups in the Answer Solutions specification guide for more information.

Standard Includes	Required to Specify
<ul style="list-style-type: none"> ▶ See Answer Solutions Specification Guide for product details. Panel skins, fabric direction application, if selected: fabric price group 1 	<ul style="list-style-type: none"> 1 Style number 2 Fabric color number for skin surface 3 Options, if selected (see below) ▶ See Surface Materials, page 480.

Options	Required to Specify
Surface Materials <ul style="list-style-type: none"> Fabric price group A Fabric price group 1 Fabric price group 2 Fabric price group 3 	<ul style="list-style-type: none"> Specify fabric color number. Specify fabric color number. Specify fabric color number. Specify fabric color number.
Fabric direction on 18"W to 60"W skins <ul style="list-style-type: none"> Vertical application 	<ul style="list-style-type: none"> Specify with vertical application.

Specification Information		
24"H	30"H	36"H
<ul style="list-style-type: none"> Width Style Number 	<ul style="list-style-type: none"> Style Number 	<ul style="list-style-type: none"> Style Number

Tackable Acoustical Skins			
18"	TS72418TKF	TS73018TKF	TS73618TKF
24"	TS72424TKF	TS73024TKF	TS73624TKF
30"	TS72430TKF	TS73030TKF	TS73630TKF
36"	TS72436TKF	TS73036TKF	TS73636TKF
42"	TS72442TKF	TS73042TKF	TS73642TKF
48"	TS72448TKF	TS73048TKF	TS73648TKF
60"	TS72460TKF	TS73060TKF	TS73660TKF
72"	TS72472TKF	TS73072TKF	TS73672TKF
42"H	48"H	60"H	

Tackable Acoustical Skins			
18"	TS74218TKF	TS74818TKF	TS76018TKF
24"	TS74224TKF	TS74824TKF	TS76024TKF
30"	TS74230TKF	TS74830TKF	TS76030TKF
36"	TS74236TKF	TS74836TKF	TS76036TKF
42"	TS74242TKF	TS74842TKF	TS76042TKF
48"	TS74248TKF	TS74848TKF	TS76048TKF
60"	TS74260TKF	TS74860TKF	TS76060TKF
72"	TS74272TKF	TS74872TKF	

Systems

Answer Steel Panel Skins

For Panel Buildups



Tip: Steel skins cannot accommodate power receptacles or communication outlets. Use the base or fabric skin for power access.

Tip: 18"H and 30"H skins only work on junctions manufactured on or after October 10, 2011.

Tip: Data and modular receptacle cutouts are available on 24"H steel skins only.

Tip: Data cutout can be placed on the left or the right side of a steel beam skin. Data cutouts cannot be placed on both left and right side of steel beam skins.

Tip: Data cutout is an option under receptacle location. Specify data cutout location under the appropriate receptacle selection. Data cutout price is added to the receptacle cutout price.





Tip: On 24"W and 30"W steel skins, hardwire receptacle cutout option will always be with a centered hardwire cutout.

Tip: On 36"W and wider steel skins, hardwire receptacle cutout option will always come with a left and a right hardwire cutout.

Tip: No data or modular receptacle cutouts are available on 18"W steel skins.

Standard Includes		Required to Specify
<ul style="list-style-type: none"> ▶ See <i>Answer Solutions Specification Guide</i> for product details. 	<ul style="list-style-type: none"> Steel panel skin: paint price group 1 	<ol style="list-style-type: none"> 1 Style number 2 Paint color number for skin surface 3 Options, if selected (see below) <ul style="list-style-type: none"> ▶ See <i>Surface Materials</i>, page 480.
Options		Required to Specify
Surface Materials	<ul style="list-style-type: none"> Paint price group 1 Paint price group 2 	Specify paint color number. Specify paint color number.
Data Cutout Only (24"H only)	<ul style="list-style-type: none"> Left modular furniture data cutout or left NEMA data cutout Right modular furniture data cutout or right NEMA data cutout 	Specify with <i>left modular furniture data cutout</i> or <i>left NEMA data cutout</i> . Specify with <i>right modular furniture data cutout</i> or <i>right NEMA data cutout</i> .
Modular Receptacle Cutout (24"H only)	<ul style="list-style-type: none"> Center receptacle cutout Center receptacle cutout with right modular furniture data cutout or right NEMA data cutout 	Specify with <i>center receptacle cutout</i> . Specify with <i>center receptacle cutout and right modular furniture data cutout</i> or <i>right NEMA data cutout</i> .
	<ul style="list-style-type: none"> Left receptacle cutout Left receptacle cutout with left modular furniture data cutout or left NEMA data cutout 	Specify with <i>left receptacle cutout</i> . Specify with <i>left receptacle cutout and left modular furniture data cutout</i> or <i>left NEMA data cutout</i> .
	<ul style="list-style-type: none"> Right receptacle cutout Right receptacle cutout with right modular furniture data cutout or right NEMA data cutout 	Specify with <i>right receptacle cutout</i> . Specify with <i>right receptacle cutout and right modular furniture data cutout</i> or <i>right NEMA data cutout</i> .
	<ul style="list-style-type: none"> Left and right receptacle cutout Left and right receptacle cutout with left modular furniture data cutout or left NEMA data cutout Left and right receptacle cutout with right modular furniture data cutout or right NEMA data cutout 	Specify with <i>left and right receptacle cutout</i> . Specify with <i>left and right receptacle cutout and left modular furniture data cutout</i> or <i>left NEMA data cutout</i> . Specify with <i>left and right receptacle cutout and right modular furniture data cutout</i> or <i>right NEMA data cutout</i> .
Hardwire Power/Data Cutouts (24"H only)	<ul style="list-style-type: none"> Hardwired with receptacle cutout Hardwired with left receptacle cutout and left modular furniture data cutout or left NEMA data cutout 	Specify with <i>receptacle cutout</i> . Specify with <i>left receptacle cutout and left modular furniture data cutout</i> or <i>left NEMA data cutout</i> .
	<ul style="list-style-type: none"> Hardwired with right receptacle cutout and right modular furniture data cutout or right NEMA data cutout 	Specify with <i>right receptacle cutout and right modular furniture data cutout</i> or <i>right NEMA data cutout</i> .

Specification Information

	12"H	18"H	24"H	30"H
• Width	 • Style Number	 • Style Number	 • Style Number	 • Style Number
18"	TS71218HS	TS71818HS	TS72418HS	TS73018HS
24"	TS71224HS	TS71824HS	TS72424HS	TS73024HS
30"	TS71230HS	TS71830HS	TS72430HS	TS73030HS
36"	TS71236HS	TS71836HS	TS72436HS	TS73036HS
42"	TS71242HS	TS71842HS	TS72442HS	TS73042HS
48"	TS71248HS	TS71848HS	TS72448HS	TS73048HS
60"	TS71260HS	TS71860HS	TS72460HS	TS73060HS
72"	TS71272HS	TS71872HS	TS72472HS	TS73072HS

	36"H
• Width	 • Style Number
18"	TS73618HS
24"	TS73624HS
30"	TS73630HS
36"	TS73636HS
42"	TS73642HS
48"	TS73648HS
60"	TS73660HS
72"	TS73672HS

Answer Steel To The Floor Skins

For Panel Buildups

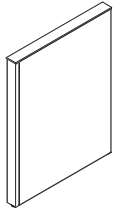

Tip: Remember to omit base trim(s) on horizontal frame package when using a skin to the floor.

Tip: Steel skins cannot accommodate power receptacles or communication outlets. Use a fabric skin for power access.

Tip: 30"H skins only work on junctions manufactured on or after October 10, 2011.

Tip: When specifying skins, the total skin height will be 6" less than the panel height. Skins to the floor are indicated by an F suffix. Plan 6" shorter than panel height, but skins to the floor are taller in actual height to cover the base trim area.

► See *Panel Buildups*, in the *Answer Solutions Specification Guide* for more information.

Tip: Data and modular receptacle cutouts are available on 24"H steel skins only.

Tip: Data cutout is an option under receptacle location. Specify data cutout location under the appropriate receptacle selection. Data cutout price is added to the receptacle cutout price.



Tip: On 24"W and 30"W steel skins, hardwire receptacle cutout option will always be with a centered hardwire cutout.

Tip: On 36"W and wider steel skins, hardwire receptacle cutout option will always come with a left and a right hardwire cutout.

Tip: No data or modular receptacle cutouts are available on 18"W steel skins.

Standard Includes		Required to Specify
<ul style="list-style-type: none"> ► See <i>Answer Solutions Specification Guide</i> for product details. 		<ul style="list-style-type: none"> 1 Style number 2 Paint color number for skin surface 3 Options, if selected (see below) ► See <i>Surface Materials</i>, page 480.
Options		Required to Specify
Surface Materials	<ul style="list-style-type: none"> • Paint price group 1 • Paint price group 2 	<ul style="list-style-type: none"> Specify paint color number. Specify paint color number.
Data Cutout Only (24"H only)	<ul style="list-style-type: none"> • Left modular furniture data cutout or left NEMA data cutout • Right modular furniture data cutout or right NEMA data cutout 	<ul style="list-style-type: none"> Specify with <i>left modular furniture data cutout</i> or <i>left NEMA data cutout</i>. Specify with <i>right modular furniture data cutout</i> or <i>right NEMA data cutout</i>.
Modular Receptacle Cutout (24"H only)	<ul style="list-style-type: none"> • Center receptacle cutout • Center receptacle cutout with right modular furniture data cutout or right NEMA data cutout 	<ul style="list-style-type: none"> Specify with <i>center receptacle cutout</i>. Specify with <i>center receptacle cutout and right modular furniture data cutout</i> or <i>right NEMA data cutout</i>.
	<ul style="list-style-type: none"> • Left receptacle cutout • Left receptacle cutout with left modular furniture data cutout or left NEMA data cutout 	<ul style="list-style-type: none"> Specify with <i>left receptacle cutout</i>. Specify with <i>left receptacle cutout and left modular furniture data cutout</i> or <i>left NEMA data cutout</i>.
	<ul style="list-style-type: none"> • Right receptacle cutout • Right receptacle cutout with right modular furniture data cutout or right NEMA data cutout 	<ul style="list-style-type: none"> Specify with <i>right receptacle cutout</i>. Specify with <i>right receptacle cutout and right modular furniture data cutout</i> or <i>right NEMA data cutout</i>.
	<ul style="list-style-type: none"> • Left and right receptacle cutout • Left and right receptacle cutout with left modular furniture data cutout or left NEMA data cutout • Left and right receptacle cutout with right modular furniture data cutout or right NEMA data cutout 	<ul style="list-style-type: none"> Specify with <i>left and right receptacle cutout</i>. Specify with <i>left and right receptacle cutout and left modular furniture data cutout</i> or <i>left NEMA data cutout</i>. Specify with <i>left and right receptacle cutout and right modular furniture data cutout</i> or <i>right NEMA data cutout</i>.
Hardwire Power/Data Cutouts (24"H only)	<ul style="list-style-type: none"> • Hardwired with receptacle cutout • Hardwired with left receptacle cutout and left modular furniture data cutout or left NEMA data cutout 	<ul style="list-style-type: none"> Specify with <i>receptacle cutout</i>. Specify with <i>left receptacle cutout and left modular furniture data cutout</i> or <i>left NEMA data cutout</i>.
	<ul style="list-style-type: none"> • Hardwired with right receptacle cutout and right modular furniture data cutout or right NEMA data cutout 	<ul style="list-style-type: none"> Specify with <i>right receptacle cutout and right modular furniture data cutout</i> or <i>right NEMA data cutout</i>.

Specification Information

	24"H	30"H	36"H
			
Width	Style Number	Style Number	Style Number
18"	TS72418HSF	TS73018HSF	TS73618HSF
24"	TS72424HSF	TS73024HSF	TS73624HSF
30"	TS72430HSF	TS73030HSF	TS73630HSF
36"	TS72436HSF	TS73036HSF	TS73636HSF
42"	TS72442HSF	TS73042HSF	TS73642HSF
48"	TS72448HSF	TS73048HSF	TS73648HSF
60"	TS72460HSF	TS73060HSF	TS73660HSF
72"	TS72472HSF	TS73072HSF	TS73672HSF



Answer Markerboard Skins

For Panel Buildups

Tip: 18"H and 30"H skins only work on junctions manufactured on or after October 10, 2011.

	Standard Includes	Required to Specify
▶ See <i>Answer Solutions Specification Guide</i> for product details.	• Markerboard skin: white	Style number

Specification Information

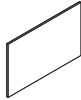
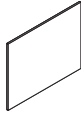
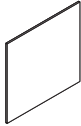
	12"H	18"H	24"H	30"H	36"H
					
• Width	• Style Number	• Style Number	• Style Number	• Style Number	• Style Number
18"	TS71218MB	TS71818MB	TS72418MB	TS73018MB	TS73618MB
24"	TS71224MB	TS71824MB	TS72424MB	TS73024MB	TS73624MB
30"	TS71230MB	TS71830MB	TS72430MB	TS73030MB	TS73630MB
36"	TS71236MB	TS71836MB	TS72436MB	TS73036MB	TS73636MB
42"	TS71242MB	TS71842MB	TS72442MB	TS73042MB	TS73642MB
48"	TS71248MB	TS71848MB	TS72448MB	TS73048MB	TS73648MB
60"	TS71260MB	TS71860MB	TS72460MB	TS73060MB	TS73660MB
72"	TS71272MB	TS71872MB	TS72472MB	TS73072MB	TS73672MB

Answer Steel Technology Skins

Tip: Remember to order technology covers to fill the cutouts. Only **TS7TSCOVER** style covers can be used with this skin.

Tip: A modular powerkit must always be located behind the technology skin.

Tip: 72"W technology skins accommodate fabric in the horizontal application only.

Tip: For further information about fabric direction, see Answer Solutions Specification Guide.

Tip: Technology skins are available with all cutouts or handed cutouts on just the right side or just the left side of the skin.

Tip: 6"H technology skins with cutouts includes a pair of powerkit brackets that attach the powerkit to the junction to correctly position it within the panel.

Tip: 6"H technology skin can only attach to junctions manufactured on or after October 10, 2011.

Tip: When using technology skin on one side of the panel (only used at worksurface height) a 12" or 18" skin can not be used on the opposite side of the panel at the same location as the 6"H skin.

Standard Includes	Required to Specify
<ul style="list-style-type: none"> See Answer Solutions Specification Guide for product details. Technology skin: paint price group 1 	<ul style="list-style-type: none"> 1 Style number 2 Paint color number for skin surface 3 Options, if selected (see below) <p>▶ See <i>Surface Materials</i>, page 480.</p>

Options	Required to Specify
Surface Materials	Specify paint color number. Specify paint color number.
Paint <ul style="list-style-type: none"> Paint price group 1 Paint price group 2 	
Fabric <ul style="list-style-type: none"> Fabric on steel technology skins Fabric price group 1 Fabric price group 2 Fabric price group 3 	Specify <i>with fabric</i> . Specify fabric color number. Specify fabric color number. Specify fabric color number.
Fabric direction <ul style="list-style-type: none"> Horizontal application (standard) Vertical application 	Specify <i>with horizontal application</i> . Specify <i>with vertical application</i> .

Specification Information			
All Cutouts	Right Hand Cutout Only	Left Hand Cutout Only	No Cutouts
<ul style="list-style-type: none"> Width Style Number 	<ul style="list-style-type: none"> Style Number 	<ul style="list-style-type: none"> Style Number 	<ul style="list-style-type: none"> Style Number

6"H Steel Technology Skins

24"	TS7624TSS		TS7624HS
30"	TS7630TSS	TS7630RTSS	TS7630HS
36"	TS7636TSS	TS7636RTSS	TS7636HS
42"	TS7642TSS	TS7642RTSS	TS7642HS
48"	TS7648TSS	TS7648RTSS	TS7648HS
60"	TS7660TSS	TS7660RTSS	TS7660HS
72"	TS7672TSS	TS7672RTSS	TS7672HS

12"H Steel Technology Skins

24"	TS71224TSS		
30"	TS71230TSS	TS71230RTSS	TS71230LTSS
36"	TS71236TSS	TS71236RTSS	TS71236LTSS
42"	TS71242TSS	TS71242RTSS	TS71242LTSS
48"	TS71248TSS	TS71248RTSS	TS71248LTSS
60"	TS71260TSS	TS71260RTSS	TS71260LTSS
72"	TS71272TSS	TS71272RTSS	TS71272LTSS

▶ Specification Information, continued on next page

Specification Information

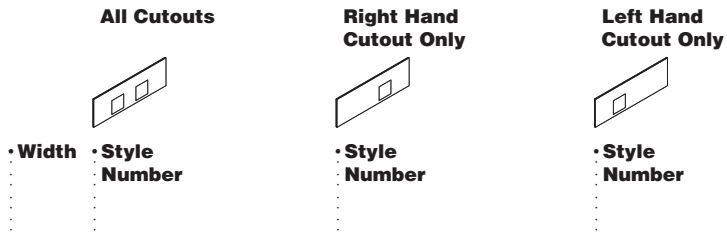

Tip: 18"H technology skin can only attach to junctions manufactured on or after October 10, 2011.

Tip: 18"H technology skins must be planned in 12"H increments from the bottom of the panel to align with powerkit locations.

18"H Steel Technology Skins

24"	TS71824TSS		
30"	TS71830TSS	TS71830RTSS	TS71830LTSS
36"	TS71836TSS	TS71836RTSS	TS71836LTSS
42"	TS71842TSS	TS71842RTSS	TS71842LTSS
48"	TS71848TSS	TS71848RTSS	TS71848LTSS
60"	TS71860TSS	TS71860RTSS	TS71860LTSS
72"	TS71872TSS	TS71872RTSS	TS71872LTSS
.....

Answer Technology Skin Cover and Fillers

Technology Skin Cover



Tip: Receptacle filler to close unused openings is available through Service Parts (**891700204MP**, package of 20).

Standard Includes	Required to Specify
<ul style="list-style-type: none"> ▶ See <i>Answer Solutions Specification Guide</i> for product details. • Technology skin cover: plastic 	<ul style="list-style-type: none"> 1 Style number 2 Plastic color number for technology skin cover: <ul style="list-style-type: none"> 6000 Black 6009 Arctic White 6249 Platinum Solid 6654 Sand 6697 Fog
Specification Information	
<ul style="list-style-type: none"> • Style Number • • 	
TS7TSCOVER <ul style="list-style-type: none"> • • 	

Technology Skin Cover Fillers

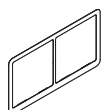

Tip: Technology skin cover filler is required when using a **TS7TSCOVER** technology skin cover on skins manufactured before November 21, 2011.

Standard Includes	Required to Specify
<ul style="list-style-type: none"> ▶ See <i>Answer Solutions Specification Guide</i> for product details. • Technology skin cover filler: paint 	<ul style="list-style-type: none"> 1 Style number 2 Paint color number for filler ▶ See <i>Surface Materials</i>, page 480.
Specification Information	
<ul style="list-style-type: none"> • Style Number • • 	<ul style="list-style-type: none"> • Description • •
TS7TSCFS	Single cutout
TS7TSCFD	Double cutout
•	•
•	•

Answer Glass Windows



For Panel Buildups

Tip: Remember to specify spanning window in-line supports if window is spanning two or more panels.

Tip: When specifying a window span over two or more panels, it is recommended that the same size spanning top cap also be specified for use with the window.

Standard Includes		Required to Specify
▶ See <i>Answer Solutions Specification Guide</i> for product details.	<ul style="list-style-type: none"> • Single-pane glass window, if selected: 6500 Clear Glass • Frame: paint 	1 Style number 2 Paint color number for frame 3 Options, if selected (see below) ▶ See <i>Surface Materials</i> , page 480.

Options		Required to Specify
Surface Materials	Frame	
	<ul style="list-style-type: none"> • Paint price group 1 • Paint price group 2 	Specify paint color number. Specify paint color number.

Specification Information			
	12"H	18"H	24"H
			
• Width	• Style Number	• Style Number	• Style Number

Single Pane			
24"	TS71224SPW	TS71824SPW	TS72424SPW
30"	TS71230SPW	TS71830SPW	TS72430SPW
36"	TS71236SPW	TS71836SPW	TS72436SPW
42"	TS71242SPW	TS71842SPW	TS72442SPW
48"	TS71248SPW	TS71848SPW	TS72448SPW
60"	TS71260SPW	TS71860SPW	TS72460SPW
72"	TS71272SPW	TS71872SPW	TS72472SPW
78"	TS71278SPW	TS71878SPW	TS72478SPW
84"	TS71284SPW	TS71884SPW	TS72484SPW
90"	TS71290SPW	TS71890SPW	TS72490SPW
96"	TS71296SPW	TS71896SPW	TS72496SPW

*Tip: When ordering a 72"W or wider single pane window to be used with steel or fabric skins located directly below it, two clips (**890146001SR**) should be ordered and installed.*

Answer Spanning Window In-Line Support and In-Line Spanning Top Cap Lightseals

Spanning Window In-Line Support

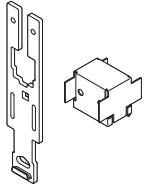

Tip: Spanning window in-line support is needed when spanning a single window across two or more panels. Specify one support for each in-line junction window spans.

Standard Includes	Required to Specify
-------------------	---------------------

- | | |
|--|--|
| <ul style="list-style-type: none"> ▶ See <i>Answer Solutions Specification Guide</i> for product details. | <ul style="list-style-type: none"> • Spanning window in-line support: black |
|--|--|

Style number

Specification Information

• **Style Number**

TS7SWS

In-Line Spanning Top Cap Lightseals



Tip: These lightseals are only needed when spanning two or more panels with a single top cap or frameless glass screen.

Standard Includes	Required to Specify
-------------------	---------------------

- | | |
|--|--|
| <ul style="list-style-type: none"> ▶ See <i>Answer Solutions Specification Guide</i> for product details. | <ul style="list-style-type: none"> • In-line top cap lightseal: black |
|--|--|

Style number

Specification Information

• Style Number	• Quantity
-----------------------	-------------------

TS7STLS1	1
-----------------	---

TS7STLS10	10
------------------	----

Cable Trays

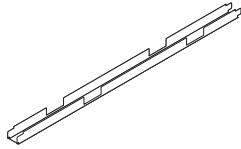

Tip: Cables may also be routed in top of powerkit.

Tip: One cable tray can be optioned at when ordering base horizontal frame or panel packages.

Tip: Cable carriers can be added to 24"–72" wide trays.
 ▶ See *Montage Specification Guide* for style number **ZCC**.

Standard Includes	Required to Specify
▶ See <i>Answer Solutions Specification Guide</i> for product details.	Style number
<ul style="list-style-type: none"> • Cable tray: black paint only 	

Specification Information		
• Dimensions		• Style
W	H	Number
18"	2"	TS718CT
24"	2"	TS724CT
30"	2"	TS730CT
36"	2"	TS736CT
42"	2"	TS742CT
48"	2"	TS748CT
60"	2"	TS760CT
72"	2"	TS772CT
:	:	:

Powerkits

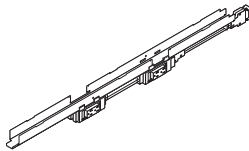

Tip: Remember to order receptacles and faceplates.

Standard Includes	Required to Specify
<ul style="list-style-type: none"> ▶ See <i>Answer Solutions Specification Guide</i> for product details. 	Style number
<ul style="list-style-type: none"> • Powerkit to accommodate modular duplex and USB receptacles on both sides: black plastic • Supporting powertray: black paint • Harness with modular connectors 	

Specification Information		
• Width	• Number of Duplex Receptacles Per Side	• Style Number

4-Circuit, 3+1 Wiring Schematic

24"	1	TS7PK24X
30"	2	TS7PK30X
36"	2	TS7PK36X
42"	2	TS7PK42X
48"	2	TS7PK48X
60"	4	TS7PK60X
72"	4	TS7PK72X
⋮	⋮	⋮

4-Circuit, 2+2 Wiring Schematic

24"	1	TS7PK24Y
30"	2	TS7PK30Y
36"	2	TS7PK36Y
42"	2	TS7PK42Y
48"	2	TS7PK48Y
60"	4	TS7PK60Y
72"	4	TS7PK72Y
⋮	⋮	⋮

3-Circuit, Separate Neutrals (3SN) Wiring Schematic

24"	1	TS7PK24Z
30"	2	TS7PK30Z
36"	2	TS7PK36Z
42"	2	TS7PK42Z
48"	2	TS7PK48Z
60"	4	TS7PK60Z
72"	4	TS7PK72Z
⋮	⋮	⋮

Pass-Through Powerkits

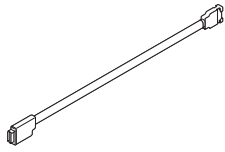

Standard Includes	Required to Specify
<ul style="list-style-type: none"> See <i>Answer Solutions Specification Guide</i> for product details. Powerkit to accommodate modular receptacles on both sides: black plastic Harness with modular connectors 	Style number

Specification Information

Width	Number of Duplex Receptacles Per Side	Style Number

4-Circuit, 3+1 Wiring Schematic

18"	0	TS7PT18X
24"	0	TS7PT24X
30"	0	TS7PT30X
36"	0	TS7PT36X
42"	0	TS7PT42X
48"	0	TS7PT48X
60"	0	TS7PT60X
72"	0	TS7PT72X
:	:	:

4-Circuit, 2+2 Wiring Schematic

18"	0	TS7PT18Y
24"	0	TS7PT24Y
30"	0	TS7PT30Y
36"	0	TS7PT36Y
42"	0	TS7PT42Y
48"	0	TS7PT48Y
60"	0	TS7PT60Y
72"	0	TS7PT72Y
:	:	:

3-Circuit, Separate Neutrals (3SN) Wiring Schematic

18"	0	TS7PT18Z
24"	0	TS7PT24Z
30"	0	TS7PT30Z
36"	0	TS7PT36Z
42"	0	TS7PT42Z
48"	0	TS7PT48Z
60"	0	TS7PT60Z
72"	0	TS7PT72Z
:	:	:

Duplex Receptacles

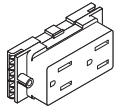

Standard Includes	Required to Specify
<ul style="list-style-type: none"> See <i>Answer Solutions Specification Guide</i> for product details. Receptacle: plastic 	<ul style="list-style-type: none"> 1 Style number 2 Plastic color number for receptacle: <ul style="list-style-type: none"> 6000 Black 6009 Arctic White 6249 Platinum Solid 6654 Sand 6697 Fog

Specification Information

15-Amp Receptacles

Line	Style Number	Style Number
:	:	:

4-Circuit, 3+1 Wiring Schematic

	System Ground	Isolated Ground
Line 1	TS71SSX	TS71SGX
Line 2	TS72SSX	TS72SGX
Line 3	TS73SSX	TS73SGX
Line 4	TS74SSX	TS74SGX
:	:	:

4-Circuit, 2+2 Wiring Schematic

	System Ground	Isolated Ground
Line 1	TS71SSY	TS71SGY
Line 2	TS72SSY	TS72SGY
Line 3	TS73SSY	TS73SGY
Line 4	TS74SSY	TS74SGY
:	:	:

3-Circuit, Separate Neutrals (3SN) Wiring Schematic

	System Ground	Isolated Ground
Line 1	TS71SSZ	TS71SGZ
Line 2	TS72SSZ	TS72SGZ
Line 3	TS73SSZ	TS73SGZ
:	:	:

Hardwired Powerkits

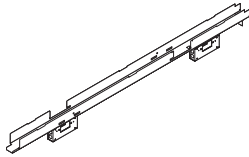

Tip: Specify hardwire base trims when accessing a hardwire powerkit in the base.

Standard Includes	Required to Specify
<ul style="list-style-type: none"> ▶ See <i>Answer Solutions Specification Guide</i> for product details. • Power tray • Junction box(es) • Cover plate(s) 	Style number

Specification Information		
Corresponding Panel Width	Number of Junction Boxes	Style Number
24"	1	TS7CPK24
30"	2	TS7CPK30
36"	2	TS7CPK36
42"	2	TS7CPK42
48"	2	TS7CPK48
60"	2	TS7CPK60
72"	2	TS7CPK72
:	:	:

Multipurpose Power Infeeds

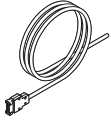

Tip: Utility poles must be specified separately.

Standard Includes	Required to Specify
<ul style="list-style-type: none"> ▶ See <i>Answer Solutions Specification Guide</i> for product details. 	<ul style="list-style-type: none"> • Multipurpose power infeed with modular connector • Insulated color-coded wires for hardwired connection to building power source
	Style number

Specification Information

Length	Style Number
:	:
:	:

4-Circuit, 3+1 Wiring Schematic

6'	TS76UPHX
12'	TS712UPHX
24'	TS724UPHX
:	:

4-Circuit, 2+2 Wiring Schematic

6'	TS76UPHY
12'	TS712UPHY
24'	TS724UPHY
:	:

3-Circuit, Separate Neutrals (3SN) Wiring Schematic

6'	TS76UPHZ
12'	TS712UPHZ
24'	TS724UPHZ
:	:

Modular Harnesses

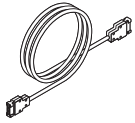

Standard Includes	Required to Specify
<ul style="list-style-type: none"> See <i>Answer Solutions Specification Guide</i> for product details. Conduit with two modular connectors: black 	Style number

Specification Information

Length	Style Number
--------	--------------

4-Circuit, 3+1 Wiring Schematic

43"	TS743MHX
80"	TS780MHX
:	:

4-Circuit, 2+2 Wiring Schematic

43"	TS743MHY
80"	TS780MHY
:	:

3-Circuit, Separate Neutrals (3SN) Wiring Schematic

43"	TS743MHZ
80"	TS780MHZ
:	:

Tackboards for Use with Wall Channels

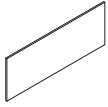

Standard Includes	Required to Specify
<ul style="list-style-type: none"> Tackboard, fabric direction with horizontal application: fabric price group 1 	<ul style="list-style-type: none"> 1 Style number 2 Fabric color number 3 Options, if selected (see below) ▶ See <i>Surface Materials</i>, page 480.

Options		Required to Specify
Surface Materials	<ul style="list-style-type: none"> Fabric price group 1 Fabric price group 2 Fabric price group 3 	<ul style="list-style-type: none"> Specify fabric color number. Specify fabric color number. Specify fabric color number.
	<p>Fabric direction on 24"W to 60"W tackboards</p> <ul style="list-style-type: none"> Vertical application 	<p>Specify with <i>vertical application</i>.</p>

Tip: 72"W tackboards accommodate fabric in the horizontal direction only.

Tip: For further information about fabric direction.

Specification Information		
• Dimensions		• Style
W	H	Number
24"	18"	TS71824TB
30"	18"	TS71830TB
36"	18"	TS71836TB
42"	18"	TS71842TB
48"	18"	TS71848TB
60"	18"	TS71860TB
72"	18"	TS71872TB

Universal Systems Worksurfaces

Parametric Straight Worksurfaces

High-Pressure Laminate

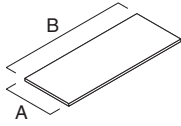

Tip: Long work surface spans require additional support.
▶ See Answer Solutions Specification Guide.

Tip: Short grain laminate is only available on surfaces 60"W or less.

Tip: When selecting with cord drop, subtract 1/2" from depth.

Tip: Scallop is available in the center location only. If cutout for power and data access door and tray or power access door is selected, scallop will default to omit scallop.

Standard Includes	Required to Specify
<ul style="list-style-type: none"> ▶ See Answer Solutions Specification Guide for product details. • Worksurface: High-Pressure Laminate price group 1 • Laminate worksurface: <ul style="list-style-type: none"> – Plastic 3 mm edge profile on front edge – Plastic default flat profile on side and back edges • Depth: 18"D–36"D • Width: 18"W–96"W 	<ol style="list-style-type: none"> 1 Style number 2 Worksurface size type (see below under Required Selections) 3 Depth (see below under Required Selections) 4 Width (see below under Required Selections) 5 High-Pressure Laminate color number for work surface 6 Plastic color number for front edge on laminate work surface 7 Options, if selected (see below) <p>▶ See Surface Materials, page 480.</p>

Required Selections		Required to Specify																														
Worksurface Size Type	<ul style="list-style-type: none"> • Modular • Parametric 	Specify with modular. Specify with parametric.																														
Depth	<table border="1"> <thead> <tr> <th>Modular</th> <th>Parametric</th> </tr> </thead> <tbody> <tr> <td>• 18⁷/₈"D</td> <td>18"D–23⁷/₁₆"D</td> </tr> <tr> <td>• 24"D</td> <td>23¹/₂"D–29⁷/₁₆"D</td> </tr> <tr> <td>• 30"D</td> <td>29¹/₂"D–35⁷/₁₆"D</td> </tr> <tr> <td>• 36"D</td> <td>35¹/₂"D–36"D</td> </tr> </tbody> </table>	Modular	Parametric	• 18 ⁷ / ₈ "D	18"D–23 ⁷ / ₁₆ "D	• 24"D	23 ¹ / ₂ "D–29 ⁷ / ₁₆ "D	• 30"D	29 ¹ / ₂ "D–35 ⁷ / ₁₆ "D	• 36"D	35 ¹ / ₂ "D–36"D	Specify depth. Specify depth. Specify depth. Specify depth.																				
Modular	Parametric																															
• 18 ⁷ / ₈ "D	18"D–23 ⁷ / ₁₆ "D																															
• 24"D	23 ¹ / ₂ "D–29 ⁷ / ₁₆ "D																															
• 30"D	29 ¹ / ₂ "D–35 ⁷ / ₁₆ "D																															
• 36"D	35 ¹ / ₂ "D–36"D																															
Width	<table border="1"> <thead> <tr> <th>Modular</th> <th>Parametric</th> </tr> </thead> <tbody> <tr> <td>• 18"W</td> <td>18"W–23¹⁵/₁₆"W</td> </tr> <tr> <td>• 24"W</td> <td>24"W–29¹⁵/₁₆"W</td> </tr> <tr> <td>• 30"W</td> <td>30"W–35¹⁵/₁₆"W</td> </tr> <tr> <td>• 36"W</td> <td>36"W–41¹⁵/₁₆"W</td> </tr> <tr> <td>• 42"W</td> <td>42"W–47¹⁵/₁₆"W</td> </tr> <tr> <td>• 48"W</td> <td>48"W–53¹⁵/₁₆"W</td> </tr> <tr> <td>• 54"W</td> <td>54"W–59¹⁵/₁₆"W</td> </tr> <tr> <td>• 60"W</td> <td>60"W–65¹⁵/₁₆"W</td> </tr> <tr> <td>• 66"W</td> <td>66"W–71¹⁵/₁₆"W</td> </tr> <tr> <td>• 72"W</td> <td>72"W–77¹⁵/₁₆"W</td> </tr> <tr> <td>• 78"W</td> <td>78"W–83¹⁵/₁₆"W</td> </tr> <tr> <td>• 84"W</td> <td>84"W–89¹⁵/₁₆"W</td> </tr> <tr> <td>• 90"W</td> <td>90"W–95¹⁵/₁₆"W</td> </tr> <tr> <td>• 96"W</td> <td>96"W</td> </tr> </tbody> </table>	Modular	Parametric	• 18"W	18"W–23 ¹⁵ / ₁₆ "W	• 24"W	24"W–29 ¹⁵ / ₁₆ "W	• 30"W	30"W–35 ¹⁵ / ₁₆ "W	• 36"W	36"W–41 ¹⁵ / ₁₆ "W	• 42"W	42"W–47 ¹⁵ / ₁₆ "W	• 48"W	48"W–53 ¹⁵ / ₁₆ "W	• 54"W	54"W–59 ¹⁵ / ₁₆ "W	• 60"W	60"W–65 ¹⁵ / ₁₆ "W	• 66"W	66"W–71 ¹⁵ / ₁₆ "W	• 72"W	72"W–77 ¹⁵ / ₁₆ "W	• 78"W	78"W–83 ¹⁵ / ₁₆ "W	• 84"W	84"W–89 ¹⁵ / ₁₆ "W	• 90"W	90"W–95 ¹⁵ / ₁₆ "W	• 96"W	96"W	Specify width. Specify width. Specify width. Specify width. Specify width. Specify width. Specify width. Specify width. Specify width. Specify width. Specify width. Specify width. Specify width. Specify width.
Modular	Parametric																															
• 18"W	18"W–23 ¹⁵ / ₁₆ "W																															
• 24"W	24"W–29 ¹⁵ / ₁₆ "W																															
• 30"W	30"W–35 ¹⁵ / ₁₆ "W																															
• 36"W	36"W–41 ¹⁵ / ₁₆ "W																															
• 42"W	42"W–47 ¹⁵ / ₁₆ "W																															
• 48"W	48"W–53 ¹⁵ / ₁₆ "W																															
• 54"W	54"W–59 ¹⁵ / ₁₆ "W																															
• 60"W	60"W–65 ¹⁵ / ₁₆ "W																															
• 66"W	66"W–71 ¹⁵ / ₁₆ "W																															
• 72"W	72"W–77 ¹⁵ / ₁₆ "W																															
• 78"W	78"W–83 ¹⁵ / ₁₆ "W																															
• 84"W	84"W–89 ¹⁵ / ₁₆ "W																															
• 90"W	90"W–95 ¹⁵ / ₁₆ "W																															
• 96"W	96"W																															

Options		Required to Specify
Surface Materials	<p>High-Pressure Laminate worksurfaces</p> <ul style="list-style-type: none"> • Laminate price group 3 <p>Wood grain direction</p> <ul style="list-style-type: none"> • No direction • Long grain • Short grain <p>Door</p> <ul style="list-style-type: none"> • Paint • Anodized aluminum 	Specify laminate color number. Specify with no direction. Specify with long grain direction. Specify with short grain direction. Specify paint color number. Specify with 8043 Clear Anodized Aluminum.
Cord Drop	<ul style="list-style-type: none"> • No cord drop • 1/2" cord drop 	Specify without cord drop. Specify with 1/2" cord drop.
Scallop	<ul style="list-style-type: none"> • Scallop • Omit scallop 	Specify with scallop. Specify with no scallop.

▶ Options, continued on next page

► Options, continued from previous page

	Options	Required to Specify
<p>Cutout for Power and Data Access Door and Tray</p> <p>Power Access Door</p>	<p>Applies to 48"W to 96"W</p> <ul style="list-style-type: none"> Cutout 	Specify with cutout for power and data access door.
	<p>Applies to 30"W to 35¹⁵/₁₆"W</p> <ul style="list-style-type: none"> No power access Power access door center 	Specify with no power access. Specify with power access door center.
	<p>Applies to 36"W to 51¹⁵/₁₆"W</p> <ul style="list-style-type: none"> No power access Power access door center Power access door left Power access door right 	Specify with no power access. Specify with power access door center. Specify with power access door left. Specify with power access door right.
	<p>Applies to 52"W to 71¹⁵/₁₆"W</p> <ul style="list-style-type: none"> No power access Power access door center Power access door left Power access door right Power access door left and right 	Specify with no power access. Specify with power access door center. Specify with power access door left. Specify with power access door right. Specify with power access door left and right.
	<p>Applies to 72"W to 96"W</p> <ul style="list-style-type: none"> No power access Power access door center Power access door left Power access door right Power access door left and right Power access door left and center Power access door right and center Power access door left, right, and center 	Specify with no power access. Specify with power access door center. Specify with power access door left. Specify with power access door right. Specify with power access door left. Specify with power access door left and center. Specify with power access door right and center. Specify with power access door left, right, and center.
<p>Grommet Cutout</p> <p>Grommet Location</p>	<ul style="list-style-type: none"> No grommet cutout 2" grommet cutout 3" grommet cutout 	Specify with no grommet cutout. Specify with 2" grommet cutout. Specify with 3" grommet cutout.
	<p>Applies to 18"W to 24¹⁵/₁₆"W</p> <ul style="list-style-type: none"> Center 	Specify with center grommet.
	<p>Applies to 25"W to 33¹⁵/₁₆"W</p> <ul style="list-style-type: none"> Center Left Right Right and left 	Specify with center grommet. Specify with left grommet. Specify with right grommet. Specify with right and left grommet.
	<p>Applies to 34"W to 96"W</p> <ul style="list-style-type: none"> Center Left Right Right and left Left and center Right and center Right, left, and center 	Specify with center grommet. Specify with left grommet. Specify with right grommet. Specify with right and left grommet. Specify with left and center grommet. Specify with right and center grommet. Specify with right, left, and center grommet.

► Specifying Information, on next page

Tip: Power and data access door and tray is ordered separately to be used with cutout.

► See Answer Solutions Specification Guide.

Tip: Cutout for power and data access door and tray is available in the center location only. Worksurface depth must be greater than 24".

Tip: Power access door option is only available on straight worksurfaces with 1/2" cord drop.

Tip: Power access door option includes the power access door and a cutout for the door in the worksurface.

Tip: If cutout for power and data access door and tray or power access door is selected, grommet will default to no grommet.

► Options, on previous page

Specification Information

Style Number	Dimensions		Modular Width					
	Modular Depth	Parametric Depth	18"W	24"W	30"W	36"W	42"W	48"W
			18"W-23 ¹⁵ / ₁₆ "W	24"W-29 ¹⁵ / ₁₆ "W	30"W-35 ¹⁵ / ₁₆ "W	36"W-41 ¹⁵ / ₁₆ "W	42"W-47 ¹⁵ / ₁₆ "W	48"W-53 ¹⁵ / ₁₆ "W

3 mm Edge Profile-Laminate

USWS	18 ⁷ / ₈ "D	18"D-23 ⁷ / ₁₆ "D						
	24"D	23 ¹ / ₂ "D-29 ⁷ / ₁₆ "D	•	•	•	•	•	•
	30"D	29 ¹ / ₂ "D-35 ⁷ / ₁₆ "D	•	•	•	•	•	•
	36"D	35 ¹ / ₂ "D-36"D	•	•	•	•	•	•

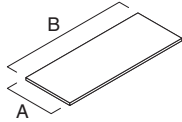

Tip: Dimension A = depth and dimension B = width.

Tip: Side and back edges of worksurface default to a flat profile.

Tip: Worksurfaces greater than 30"D can only be used in freestanding applications.

: 54"W	: 60"W	: 66"W	: 72"W	: 78"W	: 84"W	: 90"W	: 96"W
: 54"W-	: 60"W-	: 66"W-	: 72"W-	: 78"W-	: 84"W-	: 90"W-	: 96"W
: 59 ¹⁵ / ₁₆ "W	: 65 ¹⁵ / ₁₆ "W	: 71 ¹⁵ / ₁₆ "W	: 77 ¹⁵ / ₁₆ "W	: 83 ¹⁵ / ₁₆ "W	: 89 ¹⁵ / ₁₆ "W	: 95 ¹⁵ / ₁₆ "W	:
•	•	•	•	•	•	•	•
•	•	•	•	•	•	•	•
•	•	•	•	•	•	•	•
•	•	•	•	•	•	•	•
:	:	:	:	:	:	:	:

Universal Systems Worksurfaces Accessories

2½" Round Grommet



Tip: Grommet **AWAG2** is for use on worksurfaces only.

Tip: When using **AWAG2** in the Universal parametric straight worksurface, specify the 2" grommet cutout option. Actual diameter of cutout is 2¼".

Standard Includes	Required to Specify
-------------------	---------------------

- | | | |
|--|--|--|
| <ul style="list-style-type: none"> ▶ See <i>Kick Solutions Specification Guide</i> for product details. | <ul style="list-style-type: none"> • Grommet: paint or metal • Installation instructions | <ul style="list-style-type: none"> 1 Style number 2 Paint or metal color number ▶ See <i>Surface Materials</i>, page 480. |
|--|--|--|

Specification Information			
• Dimensions			• Style
D	W	Number	

2½"	2½"	AWAG2	
:	:	:	

3" Grommet Package



Tip: When using **TSAEGROM** in the Universal parametric straight worksurface, specify the 3" grommet cutout.

Standard Includes	Required to Specify
-------------------	---------------------

- | | | |
|--|---|--|
| <ul style="list-style-type: none"> ▶ See <i>Kick Solutions Specification Guide</i> for product details. | <ul style="list-style-type: none"> • Package of 10 grommets: black plastic | <ul style="list-style-type: none"> Style number |
|--|---|--|

Specification Information	
• Style	
Number	

TSAEGROM	
:	

Wire Manager



Standard Includes	Required to Specify
-------------------	---------------------

- | | | |
|---|---|--|
| <ul style="list-style-type: none"> ▶ See <i>Elective Elements Specification Guide</i> for product details. | <ul style="list-style-type: none"> • 25" wire manager with double-sided tape: black plastic only | <ul style="list-style-type: none"> Style number |
|---|---|--|

Specification Information			
• Dimensions			• Style
D	W	H	Number

1"	¾"	25"	AWVW
:	:	:	:

Universal Systems Worksurfaces Panel-Mounted Worksurface Supports

For Use with Answer Panels

Universal Systems
Worksurfaces
Panel-Mounted Worksurface
Supports

Cantilevers

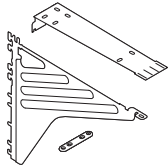

Tip: Answer panel junctions can accommodate only one cantilever at a seam.

Tip: Cantilevered straight worksurfaces greater than 26"D and 30"D transition worksurfaces require additional floor support along the front edge, such as a pedestal, end panel, post leg, side support bracket, or an adjacent return worksurface.

Standard Includes	Required to Specify
-------------------	---------------------

- | | |
|--|--|
| <ul style="list-style-type: none"> ▶ See <i>Answer Solutions Specification Guide</i> for product details. | <ul style="list-style-type: none"> • Cantilever: paint • Tie plate • Attachment hardware |
| | <ul style="list-style-type: none"> 1 Style number 2 Paint color number for cantilever ▶ See <i>Surface Materials</i>, page 480. |

Specification Information

• Style
• Number
:

On-Module Cantilever

UCANT
:

Side Support Brackets



Tip: Side support bracket includes a pair of handed brackets, only one of which is required for rear corner support of panel-mounted corner worksurfaces. Specify one for every two corner worksurfaces in on-module applications. Order an additional supply for off-module fin wall applications.

Standard Includes	Required to Specify
-------------------	---------------------

- | | |
|--|---|
| <ul style="list-style-type: none"> ▶ See <i>Answer Solutions Specification Guide</i> for product details. | <ul style="list-style-type: none"> • Pair of handed side support brackets: black paint only • Attachment hardware |
| | <ul style="list-style-type: none"> Style number |

Specification Information

• Style
• Number
:

USSBR
:

Support Plate

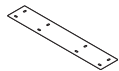

Tip: Support plate can also be used in freestanding applications.

Standard Includes	Required to Specify
-------------------	---------------------

- | | |
|--|--|
| <ul style="list-style-type: none"> ▶ See <i>Answer Solutions Specification Guide</i> for product details. | <ul style="list-style-type: none"> • Support plate: black paint only • Attachment hardware |
| | <ul style="list-style-type: none"> Style number |

Specification Information

• Dimensions
• Style
• Number
:

14"D **TS714WSP**

20"D **TS720WSP**

Universal Systems Worksurfaces Panel-Mounted
Worksurface Supports For Use with Answer Panels, continued

Tie Plates



Standard Includes		Required to Specify
<ul style="list-style-type: none"> • Package of six tie plates: black paint only • Attachment hardware 		Style number
Specification Information		
• Dimensions	• Style Number	
3¾"L	TS7TIEPLATE	

Reinforcing Channels

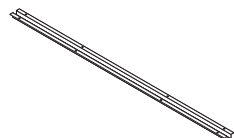

Tip: Reinforcing channel can also be used in free-standing applications.

Standard Includes		Required to Specify
<ul style="list-style-type: none"> ▶ See <i>Answer Solutions Specification Guide</i> for product details. 	<ul style="list-style-type: none"> • Reinforcing channel: black paint only • Attachment hardware 	Style number
Specification Information		
• Dimensions	• Style Number	
39"W	TS7WKSPT39	
48"W	TS7WKSPT48	
51"W	TS7WKSPT51	
54"W	TS7WKSPT54	
57"W	TS7WKSPT	
60"W	TS7WKSPT60	
63"W	TS7WKSPT63	
66"W	TS7WKSPT66	
72"W	TS7WKSPT72	

Center Support Panels

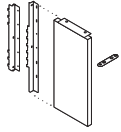

Standard Includes		Required to Specify
▶ See <i>Answer Solutions Specification Guide</i> for product details.	• Center support panel: paint price group 1	1 Style number
	• Tie plate	2 Paint color number for center support panel
	• Attachment hardware	3 Options, if selected (see below)
		▶ See <i>Surface Materials</i> , page 480.

Options		Required to Specify
Surface Materials	• Paint price group 1	Specify paint color number.
	• Paint price group 2	Specify paint color number.

Specification Information		
Dimensions		Style Number
D	H	
11"	28½"	UCSP
Standing Height		
11"	40 ⁷ / ₈ "	UCSPS

End Panels

Standard Includes		Required to Specify
▶ See <i>Answer Solutions Specification Guide</i> for product details.	• End panel: paint price group 1	1 Style number
	• Attachment hardware	2 Paint color number for end panel
		3 Options, if selected (see below)
		▶ See <i>Surface Materials</i> , page 480.

Options		Required to Specify
Surface Materials	• Paint price group 1	Specify paint color number.
	• Paint price group 2	Specify paint color number.

Specification Information		
Dimensions		Style Number
D	H	
24"	28½"	UEP24
30"	28½"	UEP30
Standing Height		
24"	40 ⁷ / ₈ "	UEP24S
30"	40 ⁷ / ₈ "	UEP30S

Universal Systems Worksurfaces Flush-Mount Bracket



	Standard Includes	Required to Specify
▶ See <i>Answer Solutions Specification Guide</i> for product details.	<ul style="list-style-type: none">• Flush-mount brackets: black paint only• Attachment hardware	Style number

Specification Information

• **Style**
• **Number**

UFB

Universal Systems Worksurfaces FrameOne Legs and Supports

Universal Systems
Worksurfaces FrameOne
Legs and Supports

Standard Includes		Required to Specify
<ul style="list-style-type: none"> ▶ See <i>Answer Solutions Specification Guide</i> for product details. 	<ul style="list-style-type: none"> • Legs and intermediate support: paint • Attachment hardware 	<ul style="list-style-type: none"> 1 Style number 2 Paint color number for legs and support 3 Options, if selected (see below) ▶ See <i>Surface Materials</i>, page 480.

Options		Required to Specify
Surface Materials	For legs <ul style="list-style-type: none"> • Paint price group 1 • Paint price group 2 	Specify paint color. Specify paint color.
	For intermediate support <ul style="list-style-type: none"> • Paint price group 1 • Paint price group 2 	Specify paint color. Specify paint color.
Intermediate Support bracing	For laminate or wood storage tops <ul style="list-style-type: none"> • No brace 	Specify <i>with no brace</i> .
	For steel storage tops <ul style="list-style-type: none"> • One brace (30", 36", or 42"W) • Two braces (30", 36", or 42"W) 	Specify <i>with one brace</i> . Specify <i>with two braces</i> .

Specification Information					
Dimensions		Style	Style	Style	Style
D	H	Number	Number	Number	Number
·	·	·	·	·	·
·	·	·	·	·	·

Closed Loop					
		Panel Supporting Left-Hand	Panel Supporting Right-Hand	Tethered Application	Table Application
24"	28½"	UFC24LHANS	UFC24RHANS	UFC24	UFC24T
30"	28½"	UFC30LHANS	UFC30RHANS	UFC30	UFC30T
·	·	·	·	·	·

Open Loop					
24"	28½"	UFQ24LHANS	UFQ24RHANS	UFQ24	UFQ24T
30"	28½"	UFQ30LHANS	UFQ30RHANS		UFQ30T
·	·	·	·	·	·

Half Loop					
24"	28½"	UFH24LHANS	UFH24RHANS		
30"	28½"	UFH30LHANS	UFH30RHANS		
·	·	·	·	·	·

Post Leg					
N.A.	28½"	UFP			
·	·	·	·	·	·

Intermediate Support					
For Use with One-High Universal Storage					
16"	11⅛"	UFS1610H			
·	·	·	·	·	·

For Use with 1.5-High Universal Storage					
16"	5⅛"	UFS1615H			
·	·	·	·	·	·

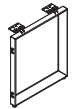

Universal Systems Worksurfaces Legs and Columns

Without Alignment Tab

Post Legs and Double Post Legs

Tip: Height dimensions listed are nominal and include the thickness of a worksurface.

Tip: Standing height legs can be used as column support in panel-mounted applications only.

Tip: Corner worksurfaces require a leg in the back corner. Be sure to order fifth leg if specifying a package of four.

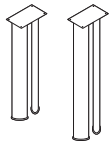
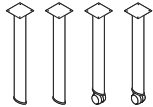

Tip: Double post legs can be used as a shared or column support in applications with other post legs.

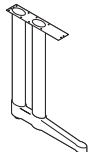

Standard Includes	Required to Specify
-------------------	---------------------

- | | |
|--|---|
| <ul style="list-style-type: none"> ▶ See <i>Answer Solutions Specification Guide</i> for product details. | <ul style="list-style-type: none"> • Legs: paint • Attachment hardware • Non-locking caster, if selected: black plastic only |
| | <ul style="list-style-type: none"> 1 Style number 2 Paint color number for leg 3 Options, if selected (see below) ▶ See <i>Surface Materials</i>, page 480. |

Options	Required to Specify
---------	---------------------

- | | |
|--------------------------|--|
| Surface Materials | <ul style="list-style-type: none"> • Paint price group 1 • Paint price group 2 |
| | <ul style="list-style-type: none"> Specify paint color number. Specify paint color number. |

Specification Information			
Planning Height	Style Number	Planning Height	Style Number

26"	UNPL	26"	UNPL4
28½"	UPL	28½"	UPL4
40⅞"	UHPL	:	:
:	:	:	:

Specification Information			
Planning Height	Style Number	Planning Height	Style Number

26"	UNPLC	26"	UNPL4C
28½"	UPLC	28½"	UPL4C
:	:	:	:
:	:	:	:

Specification Information			
Planning Height	Style Number	Planning Height	Style Number

26"	UNPLC	26"	UNPL4C
28½"	UPLC	28½"	UPL4C
:	:	:	:
:	:	:	:

Specification Information			
Planning Height	Style Number	Planning Height	Style Number

28½"	UDPL	28½"	UDPL4M
40⅞"	UHDPL	:	:
:	:	:	:
:	:	:	:

Specification Information			
Planning Height	Style Number	Planning Height	Style Number

28½"	UDPL	28½"	UDPL4M
40⅞"	UHDPL	:	:
:	:	:	:
:	:	:	:

Specification Information			
Planning Height	Style Number	Planning Height	Style Number

28½"	UDPL	28½"	UDPL4M
40⅞"	UHDPL	:	:
:	:	:	:
:	:	:	:

Specification Information			
Planning Height	Style Number	Planning Height	Style Number

28½"	UCL	28½"	UCL
:	:	:	:
:	:	:	:
:	:	:	:

Column

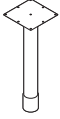

Tip: Columns have a different aesthetic than post legs (round vs. elliptical). Columns can be used as column supports in applications without post legs.

Tip: Height dimensions listed include the thickness of a worksurface.

Standard Includes		Required to Specify
<ul style="list-style-type: none"> ▶ See <i>Answer Solutions Specification Guide</i> for product details. 	<ul style="list-style-type: none"> • Column: paint • Attachment hardware 	<ul style="list-style-type: none"> 1 Style number 2 Paint color number for column 3 Options, if selected (see below) ▶ See <i>Surface Materials</i>, page 480.

Options		Required to Specify
Surface Materials	<ul style="list-style-type: none"> • Paint price group 1 • Paint price group 2 	<ul style="list-style-type: none"> Specify paint color number. Specify paint color number.

Specification Information

Planning Height	Style Number
28 1/2"	UCOL

Universal Worksurface Wire Managers

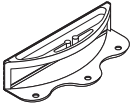

Standard Includes		Required to Specify
<ul style="list-style-type: none"> ▶ See <i>Answer Solutions Specification Guide</i> for product details. 	<ul style="list-style-type: none"> • Set of six field installed worksurface wire managers: plastic • Attachment hardware 	<ul style="list-style-type: none"> 1 Style number 2 Plastic color number for worksurface wire manager: <ul style="list-style-type: none"> 6000 Black 6009 Arctic White 6249 Platinum Solid 6654 Sand 6697 Fog

Specification Information

Style Number
TS7WWM

Currency Desk Shells and Desks with Pedestals

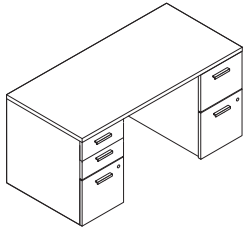

Tip: The actual thickness between Low-Pressure Laminate (LPL) and High-Pressure Laminate (HPL) worksurfaces is slightly different. It is recommended that only worksurfaces of the same type are specified in a given application. In addition, there may be sheen or texture differences when using LPL and HPL in adjacent applications.

	Standard Includes	Required to Specify
▶ See <i>Currency Specification Guide</i> for product details.	<ul style="list-style-type: none"> • 28⁷/₁₆"H desk and desk shells with pedestal, if specified: <ul style="list-style-type: none"> – Low-Pressure Laminate case with matching or contrasting Low-Pressure Laminate headset – Low-Pressure Laminate case with High-Pressure Laminate headset, if selected – High-Pressure Laminate case with matching or contrasting High-Pressure Laminate headset, if selected • 1¹/₈" thick top: <ul style="list-style-type: none"> – Low-Pressure Laminate price group 1 – High-Pressure Laminate price group 1, if selected • 3 mm edgeband on user's side: plastic price group 1 • 1 mm edgeband on sides and back: plastic price group 1 • Finished back • Modesty panel, full or quarter height • Bore and dowel drawer construction: black • One fastened plastic filing system per file drawer: black only • Full extension, heavy-duty ball bearing drawer suspensions • Lock plug • One counterweight on single pedestal desk • Two counterweights on dual pedestal desk • 1¹/₄" adjustable leveling glides • Desk shells shipped ready to assemble • Desk with pedestal(s) shipped fully assembled • One pencil tray is included in units with a box drawer 	<ol style="list-style-type: none"> 1 Style number 2 Worksurface size type (see below under Required Selections) 3 Depth (see below under Required Selections) 4 Width (see below under Required Selections) 5 Low-Pressure Laminate or High-Pressure Laminate color number for worksurface 6 Plastic color number for all edges on laminate worksurface 7 Low-Pressure Laminate or High-Pressure Laminate color number for case 8 Low-Pressure Laminate or High-Pressure Laminate color number for headset 9 Pulls, if selected (see below under Required Selections) 7 Right and left support pedestals, if selected (see below under Required Selections) 10 Options, if selected (see below) <ul style="list-style-type: none"> ▶ See <i>Surface Materials</i>, page 480. <i>Tip: Remember to specify lock cylinder and key.</i> ▶ <i>Lock Cylinders</i>, page 441

	Required Selections	Required to Specify
Size Type	• Modular	Specify <i>with modular</i> .
Depth	• 18 ⁷ / ₈ "D • 24"D • 30"D	Specify 18 ⁷ / ₈ " depth. Specify 24" depth. Specify 30" depth.
Width	• 36"W • 42"W • 48"W • 54"W • 60"W • 66"W • 72"W • 84"W • 96"W	Specify 36" width. Specify 42" width. Specify 48" width. Specify 54" width. Specify 60" width. Specify 66" width. Specify 72" width. Specify 84" width. Specify 96" width.
Support—Right	• Box/box/file pedestal • Clear-access end panel • File/file pedestal • Full depth end panel • Open/box/file pedestal	Specify <i>with box/box/file pedestal</i> . Specify <i>with clear-access end panel</i> . Specify <i>with file/file pedestal</i> . Specify <i>with full depth end panel</i> . Specify <i>with open/box/file pedestal</i> .
Support—Left	• Box/box/file pedestal • Clear-access end panel • File/file pedestal • Full depth end panel • Open/box/file pedestal	Specify <i>with box/box/file pedestal</i> . Specify <i>with clear-access end panel</i> . Specify <i>with file/file pedestal</i> . Specify <i>with full depth end panel</i> . Specify <i>with open/box/file pedestal</i> .

Tip: Lock for the box/box/file configuration does not lock the top box drawer.

Tip: Full depth end panels are required for any stand alone desk shell. When one or more clear-access end panels are used, the desk shell must be attached to an adjoining worksurface(s).

Pull Shape

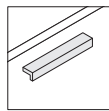

Ledge

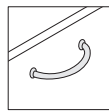

Handle

Tip: Grain direction of modesty panel runs horizontally. Grain direction of pedestals runs vertically.

	Options	Required to Specify	
Surface Materials	Top		
	<ul style="list-style-type: none"> Low-Pressure Laminate (LPL) price group 1 High-Pressure Laminate (HPL) price group 1 High-Pressure Laminate (HPL) price group 3 	Specify laminate color number. Specify laminate color number. Specify laminate color number.	
	Case		
	<ul style="list-style-type: none"> Low-Pressure Laminate (LPL) price group 1 High-Pressure Laminate (HPL) price group 1 High-Pressure Laminate (HPL) price group 3 	Specify laminate color number. Specify laminate color number. Specify laminate color number.	
Pull	Headset		
	<ul style="list-style-type: none"> Low-Pressure Laminate (LPL) price group 1 High-Pressure Laminate (HPL) price group 1 High-Pressure Laminate (HPL) price group 3 	Specify laminate color number. Specify laminate color number. Specify laminate color number.	
	<ul style="list-style-type: none"> Handle Ledge 	Specify with <i>handle pull</i> . Specify with <i>ledge pull</i> .	
Modesty Panel	<ul style="list-style-type: none"> Full Quarter height 	Specify with <i>full panel</i> . Specify with <i>quarter height panel</i> .	
	Counterweight	<ul style="list-style-type: none"> No counterweight With counterweight 	Specify with <i>no counterweight</i> . Specify with <i>counterweight</i> .
Grommet Location	<ul style="list-style-type: none"> No grommet Left Right Center Right and left Right and center Left and center Right, left, and center 	Specify with <i>no grommet</i> . Specify with <i>left grommet</i> . Specify with <i>right grommet</i> . Specify with <i>center grommet</i> . Specify with <i>right and left grommet</i> . Specify with <i>right and center grommet</i> . Specify with <i>left and center grommet</i> . Specify with <i>right, left, and center grommet</i> .	
	Keys	<ul style="list-style-type: none"> Key plug Master key plug 	Specify with <i>key plug</i> . Specify with <i>master key plug</i> .

Tip: 72"W or greater desk shells cannot receive center grommet due to required center support.

► **Specification Information, on next page**

► Options, on previous page

Specification Information

• Dimensions		• Style • Number	• Modular Depth		
• Modular • Width	• Height		• 18 ⁷ / ₈ "	• 24"	• 30"

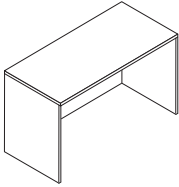

Desk Shell with Two Full Depth or Clear-Access End Panels

Low-Pressure Laminate Case

36"	28 ⁷ / ₁₆ "	CRDShL	•	•	•
42"	28 ⁷ / ₁₆ "	CRDShL	•	•	•
48"	28 ⁷ / ₁₆ "	CRDShL	•	•	•
54"	28 ⁷ / ₁₆ "	CRDShL	•	•	•
60"	28 ⁷ / ₁₆ "	CRDShL	•	•	•
66"	28 ⁷ / ₁₆ "	CRDShL	•	•	•
72"	28 ⁷ / ₁₆ "	CRDShL	•	•	•
84"	28 ⁷ / ₁₆ "	CRDShL	•	•	•
96"	28 ⁷ / ₁₆ "	CRDShL	•	•	•

High-Pressure Laminate Case

36"	28 ⁷ / ₁₆ "	CRDShL	•	•	•
42"	28 ⁷ / ₁₆ "	CRDShL	•	•	•
48"	28 ⁷ / ₁₆ "	CRDShL	•	•	•
54"	28 ⁷ / ₁₆ "	CRDShL	•	•	•
60"	28 ⁷ / ₁₆ "	CRDShL	•	•	•
66"	28 ⁷ / ₁₆ "	CRDShL	•	•	•
72"	28 ⁷ / ₁₆ "	CRDShL	•	•	•
84"	28 ⁷ / ₁₆ "	CRDShL	•	•	•
96"	28 ⁷ / ₁₆ "	CRDShL	•	•	•

► Specification Information, continued on next page

► **Specification Information, continued from previous page**

Specification Information

• Dimensions		• Style	• Modular Depth	
Modular Width	Height	Number	24"	30"

Single Pedestal Desk

Pedestal Left, Low-Pressure Laminate Case and Headset

60"	28 ⁷ / ₁₆ "	CRDSKSPL	•	•
66"	28 ⁷ / ₁₆ "	CRDSKSPL	•	•
72"	28 ⁷ / ₁₆ "	CRDSKSPL	•	•

Pedestal Left, Low-Pressure Laminate Case and High-Pressure Laminate Headset

60"	28 ⁷ / ₁₆ "	CRDSKSPL	•	•
66"	28 ⁷ / ₁₆ "	CRDSKSPL	•	•
72"	28 ⁷ / ₁₆ "	CRDSKSPL	•	•

Pedestal Left, High-Pressure Laminate Case and Headset

60"	28 ⁷ / ₁₆ "	CRDSKSPL	•	•
66"	28 ⁷ / ₁₆ "	CRDSKSPL	•	•
72"	28 ⁷ / ₁₆ "	CRDSKSPL	•	•

Pedestal Right, Low-Pressure Laminate Case and Headset

60"	28 ⁷ / ₁₆ "	CRDSKSPR	•	•
66"	28 ⁷ / ₁₆ "	CRDSKSPR	•	•
72"	28 ⁷ / ₁₆ "	CRDSKSPR	•	•

Pedestal Right, Low-Pressure Laminate Case and High-Pressure Laminate Headset

60"	28 ⁷ / ₁₆ "	CRDSKSPR	•	•
66"	28 ⁷ / ₁₆ "	CRDSKSPR	•	•
72"	28 ⁷ / ₁₆ "	CRDSKSPR	•	•

Pedestal Right, High-Pressure Laminate Case and Headset

60"	28 ⁷ / ₁₆ "	CRDSKSPR	•	•
66"	28 ⁷ / ₁₆ "	CRDSKSPR	•	•
72"	28 ⁷ / ₁₆ "	CRDSKSPR	•	•

Dual Pedestal Desk

Low-Pressure Laminate Case and Headset

60"	28 ⁷ / ₁₆ "	CRDSKDP	•	•
66"	28 ⁷ / ₁₆ "	CRDSKDP	•	•
72"	28 ⁷ / ₁₆ "	CRDSKDP	•	•

Low-Pressure Laminate Case and High-Pressure Laminate Headset

60"	28 ⁷ / ₁₆ "	CRDSKDP	•	•
66"	28 ⁷ / ₁₆ "	CRDSKDP	•	•
72"	28 ⁷ / ₁₆ "	CRDSKDP	•	•

High-Pressure Laminate Case and Headset

60"	28 ⁷ / ₁₆ "	CRDSKDP	•	•
66"	28 ⁷ / ₁₆ "	CRDSKDP	•	•
72"	28 ⁷ / ₁₆ "	CRDSKDP	•	•

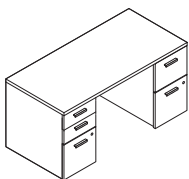
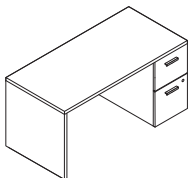
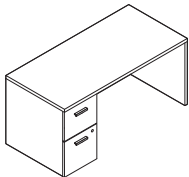

Currency Desk Shells and Desks with 6" Overhang

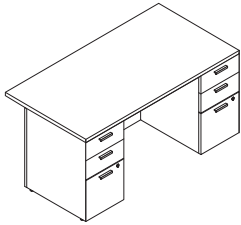

Tip: The actual thickness between Low-Pressure Laminate (LPL) and High-Pressure Laminate (HPL) worksurfaces is slightly different. It is recommended that only worksurfaces of the same type are specified in a given application. In addition, there may be sheen or texture differences when using LPL and HPL in adjacent applications.

Tip: 36"D desks have a 6" overhang on the visitor side. Pedestals and end panels are 30"D.

Tip: Lock for the box/box/file configuration does not lock the top box drawer.

Tip: Full depth end panels are required for any stand alone desk shell. When one or more clear-access end panels are used, the desk shell must be attached to an adjoining worksurface(s).

Standard Includes		Required to Specify
<ul style="list-style-type: none"> ▶ See <i>Currency Specification Guide</i> for product details. 	<ul style="list-style-type: none"> • Desk and desk shells with pedestal, if specified: <ul style="list-style-type: none"> – Low-Pressure Laminate case with matching or contrasting Low-Pressure Laminate headset – Low-Pressure Laminate case with High-Pressure Laminate headset, if selected – High-Pressure Laminate case with matching or contrasting High-Pressure Laminate headset, if selected • 1 1/8" thick top: <ul style="list-style-type: none"> – Low-Pressure Laminate price group 1 – High-Pressure Laminate price group 1, if selected • 3 mm edgeband on user's side: plastic price group 1 • 1 mm edgeband on sides and back: plastic price group 1 • Finished back • Modesty panel, full height • Bore and dowel drawer construction: black • One fastened plastic filing system per file drawer: black only • Full extension, heavy-duty ball bearing drawer suspensions • Lock plug • Two counterweights on desks • 1 1/4" adjustable leveling glides • Desk shells shipped ready to assemble • Desk with pedestal(s) shipped fully assembled • One pencil tray is included in units with a box drawer 	<ol style="list-style-type: none"> 1 Style number 2 Worksurface size type (see below under Required Selections) 3 Depth (see below under Required Selections) 4 Width (see below under Required Selections) 5 Low-Pressure Laminate or High-Pressure Laminate color number for worksurface 6 Plastic color number for all edges on laminate worksurface 7 Low-Pressure Laminate or High-Pressure Laminate color number for case 8 Low-Pressure Laminate or High-Pressure Laminate color number for headset 9 Pulls, if selected (see below under Required Selections) 10 Right and left support pedestals, if selected (see below under Required Selections) 11 Options, if selected (see below) <ul style="list-style-type: none"> ▶ See <i>Surface Materials</i>, page 480. <i>Tip: Remember to specify lock cylinder and key.</i> ▶ <i>Lock Cylinders</i>, page 441

Required Selections		Required to Specify
Size Type	• Modular	Specify <i>with modular</i> .
Depth	• 36"D	Specify 36" depth.
Width	<ul style="list-style-type: none"> • 36"W • 42"W • 48"W • 54"W • 60"W • 66"W • 72"W • 84"W • 96"W 	<ul style="list-style-type: none"> Specify 36" width. Specify 42" width. Specify 48" width. Specify 54" width. Specify 60" width. Specify 66" width. Specify 72" width. Specify 84" width. Specify 96" width.
Support—Right	<ul style="list-style-type: none"> • Box/box/file pedestal • File/file pedestal • Full depth end panel • Open/box/file pedestal 	<ul style="list-style-type: none"> Specify <i>with box/box/file pedestal</i>. Specify <i>with file/file pedestal</i>. Specify <i>with full depth end panel</i>. Specify <i>with open/box/file pedestal</i>.
Support—Left	<ul style="list-style-type: none"> • Box/box/file pedestal • File/file pedestal • Full depth end panel • Open/box/file pedestal 	<ul style="list-style-type: none"> Specify <i>with box/box/file pedestal</i>. Specify <i>with file/file pedestal</i>. Specify <i>with full depth end panel</i>. Specify <i>with open/box/file pedestal</i>.

Pull Shape

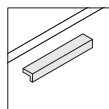

Ledge

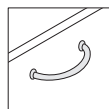

Handle

Tip: Grain direction of mod-
esty panel runs horizontally.
Grain direction of pedestals
runs vertically.

Options		Required to Specify
Surface Materials	Top	
	<ul style="list-style-type: none"> Low-Pressure Laminate (LPL) price group 1 High-Pressure Laminate (HPL) price group 1 High-Pressure Laminate (HPL) price group 3 	Specify laminate color number. Specify laminate color number. Specify laminate color number.
	Case	
	<ul style="list-style-type: none"> Low-Pressure Laminate (LPL) price group 1 High-Pressure Laminate (HPL) price group 1 High-Pressure Laminate (HPL) price group 3 	Specify laminate color number. Specify laminate color number. Specify laminate color number.
	Headset	
	<ul style="list-style-type: none"> Low-Pressure Laminate (LPL) price group 1 High-Pressure Laminate (HPL) price group 1 High-Pressure Laminate (HPL) price group 3 	Specify laminate color number. Specify laminate color number. Specify laminate color number.
Pull	<ul style="list-style-type: none"> Handle Ledge 	Specify with <i>handle pull</i> . Specify with <i>ledge pull</i> .
Counterweight	<ul style="list-style-type: none"> No counterweight With counterweight 	Specify with <i>no counterweight</i> . Specify with <i>counterweight</i> .
Grommet Location	<ul style="list-style-type: none"> No grommet Left Right Center Right and left Right and center Left and center Right, left, and center 	Specify with <i>no grommet</i> . Specify with <i>left grommet</i> . Specify with <i>right grommet</i> . Specify with <i>center grommet</i> . Specify with <i>right and left grommet</i> . Specify with <i>right and center grommet</i> . Specify with <i>left and center grommet</i> . Specify with <i>right, left, and center grommet</i> .
Keys	<ul style="list-style-type: none"> Key plug Master key plug 	Specify with <i>key plug</i> . Specify with <i>master key plug</i> .

Tip: 72"W or greater desk
shells cannot receive center
grommet due to required
center support.

Specification Information					
Dimensions			Style	LPL	HPL
Modular Depth	Modular Width	Height	Number	Case	Case
:	:	:	:	:	:
:	:	:	:	:	:

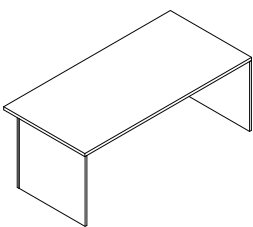

Desk Shell with 6" Overhang					
36"	36"	28 ⁷ / ₁₆ "	CRDSHLO	•	•
36"	42"	28 ⁷ / ₁₆ "	CRDSHLO	•	•
36"	48"	28 ⁷ / ₁₆ "	CRDSHLO	•	•
36"	54"	28 ⁷ / ₁₆ "	CRDSHLO	•	•
36"	60"	28 ⁷ / ₁₆ "	CRDSHLO	•	•
36"	66"	28 ⁷ / ₁₆ "	CRDSHLO	•	•
36"	72"	28 ⁷ / ₁₆ "	CRDSHLO	•	•
36"	84"	28 ⁷ / ₁₆ "	CRDSHLO	•	•
36"	96"	28 ⁷ / ₁₆ "	CRDSHLO	•	•
:	:	:	:	:	:

► Specification Information, continued on next page

► Specification Information, continued from previous page

Specification Information

• Dimensions			• Style Number	• LPL Case		• HPL Case
Modular Depth	Modular Width	Height		LPL Headset	HPL Headset	HPL Headset

Desk—Single Pedestal, Right-Hand, 6" Overhang

36"	60"	28 ⁷ / ₁₆ "	CRDSKOSPR	•	•	•
36"	66"	28 ⁷ / ₁₆ "	CRDSKOSPR	•	•	•
36"	72"	28 ⁷ / ₁₆ "	CRDSKOSPR	•	•	•

Desk—Single Pedestal, Left-Hand, 6" Overhang

36"	60"	28 ⁷ / ₁₆ "	CRDSKOSPL	•	•	•
36"	66"	28 ⁷ / ₁₆ "	CRDSKOSPL	•	•	•
36"	72"	28 ⁷ / ₁₆ "	CRDSKOSPL	•	•	•

Desk—Dual Pedestal, 6" Overhang

36"	60"	28 ⁷ / ₁₆ "	CRDSKODP	•	•	•
36"	66"	28 ⁷ / ₁₆ "	CRDSKODP	•	•	•
36"	72"	28 ⁷ / ₁₆ "	CRDSKODP	•	•	•

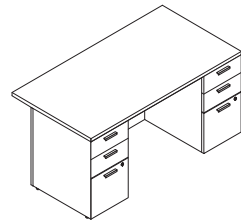
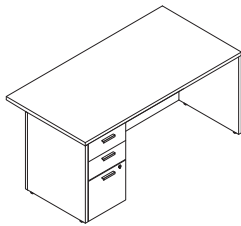
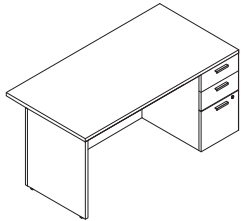

Currency Bow Front Desk Shells and Desks with Pedestals

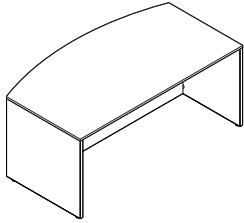

Tip: The actual thickness between Low-Pressure Laminate (LPL) and High-Pressure Laminate (HPL) worksurfaces is slightly different. It is recommended that only worksurfaces of the same type are specified in a given application. In addition, there may be sheen or texture differences when using LPL and HPL in adjacent applications.

► See *Currency Specification Guide* for product details.

Standard Includes

- Desk and desk shells with pedestal, if specified:
 - Low-Pressure Laminate case with matching or contrasting Low-Pressure Laminate headset
 - Low-Pressure Laminate case with High-Pressure Laminate headset, if selected
 - High-Pressure Laminate case with matching or contrasting High-Pressure Laminate headset, if selected
- 1 1/8" thick top
 - Low-Pressure Laminate price group 01
 - High-Pressure Laminate price group 01, if selected
- 3 mm edgeband on user's side: plastic group 01
- 1 mm edgeband on sides and back: plastic price group 01
- Finished back
- Modesty panel, full height
- Bore and dowel drawer construction: black
- One fastened plastic filing system per file drawer: black only
- Full extension, heavy-duty ball bearing drawer suspensions
- Lock plug
- Counterweight, if desk with single pedestal selected
- Two counterweights, if desk with double pedestal selected
- 1 1/4" adjustable leveling glides
- Desk shells shipped ready to assemble
- Desk with pedestal(s) shipped fully assembled
- One pencil tray is included in units with a box drawer

Required to Specify

- 1 Style number
- 2 Worksurface size type (see below under Required Selections)
- 3 Depth (see below under Required Selections)
- 4 Width (see below under Required Selections)
- 5 Low-Pressure Laminate or High-Pressure Laminate color number for worksurface
- 6 Plastic color number for all edges on laminate worksurface
- 7 Low-Pressure Laminate or High-Pressure Laminate color number for case
- 8 Low-Pressure Laminate or High-Pressure Laminate color number for headset
- 9 Pulls, if selected (see below under Required Selections)
- 10 Right and left support pedestals, if selected (see below under Required Selections)
- 11 Options, if selected (see below)
 - See *Surface Materials*, page 480.

	Required Selections	Required to Specify
Size Type	• Modular	Specify <i>with modular</i> .
Depth	• 36"D • 42"D	Specify 36" depth. Specify 42" depth.
Width	• 66"W • 72"W • 84"W • 96"W	Specify 66" width. Specify 72" width. Specify 84" width. Specify 96" width.
Support—Right	• Box/box/file pedestal • File/file pedestal • Full depth end panel • Open/box/file pedestal	Specify <i>with box/box/file pedestal</i> . Specify <i>with file/file pedestal</i> . Specify <i>with full depth end panel</i> . Specify <i>with open/box/file pedestal</i> .
Support—Left	• Box/box/file pedestal • File/file pedestal • Full depth end panel • Open/box/file pedestal	Specify <i>with box/box/file pedestal</i> . Specify <i>with file/file pedestal</i> . Specify <i>with full depth end panel</i> . Specify <i>with open/box/file pedestal</i> .

Pull Shape

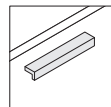

Ledge

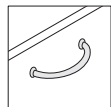

Handle

Tip: Depth is planning depth of worksurface, peak of bow to user edge.

Tip: Lock for the box/box/file configuration does not lock the top box drawer.

Tip: Grain direction of mod-
esty panel runs horizontally.
Grain direction of pedestals
runs vertically.

Tip: Counterweight type and
quantity varies depending
on storage configuration.
Please refer to the electronic
catalog or SmartTools.

Tip: 72"W or greater desk
shells cannot receive center
grommet due to center
support.

Options		Required to Specify
Surface Materials	Top	
	<ul style="list-style-type: none"> Low-Pressure Laminate (LPL) price group 1 High-Pressure Laminate (HPL) price group 1 High-Pressure Laminate (HPL) price group 3 	Specify laminate color number. Specify laminate color number. Specify laminate color number.
	Case	
	<ul style="list-style-type: none"> Low-Pressure Laminate (LPL) price group 1 High-Pressure Laminate (HPL) price group 1 High-Pressure Laminate (HPL) price group 3 	Specify laminate color number. Specify laminate color number. Specify laminate color number.
	Headset	
	<ul style="list-style-type: none"> Low-Pressure Laminate (LPL) price group 1 High-Pressure Laminate (HPL) price group 1 High-Pressure Laminate (HPL) price group 3 	Specify laminate color number. Specify laminate color number. Specify laminate color number.
Pull	<ul style="list-style-type: none"> Handle Ledge 	Specify with handle pull. Specify with ledge pull.
Counterweight	<ul style="list-style-type: none"> No counterweight With counterweight 	Specify with no counterweight. Specify with counterweight.
Grommet Location	<ul style="list-style-type: none"> No grommet Left Right Center Right and left Right and center Left and center Right, left, and center 	Specify with no grommet. Specify with left grommet. Specify with right grommet. Specify with center grommet. Specify with right and left grommet. Specify with right and center grommet. Specify with left and center grommet. Specify with right, left, and center grommet.
Keys	<ul style="list-style-type: none"> Key plug Master key plug 	Specify with key plug. Specify with master key plug.

Specification Information					
Dimensions			Style	LPL	HPL
Modular Depth	Modular Width	Modular Height	Number	Case	Case

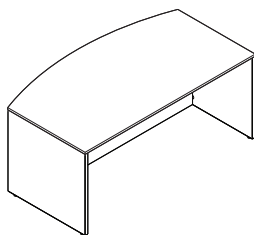

Bow-Front Desk Shells

36"	66"	28 ⁷ / ₁₆ "	CRDShLB	•	•
36"	72"	28 ⁷ / ₁₆ "	CRDShLB	•	•
36"	84"	28 ⁷ / ₁₆ "	CRDShLB	•	•
36"	96"	28 ⁷ / ₁₆ "	CRDShLB	•	•
42"	66"	28 ⁷ / ₁₆ "	CRDShLB	•	•
42"	72"	28 ⁷ / ₁₆ "	CRDShLB	•	•
42"	84"	28 ⁷ / ₁₆ "	CRDShLB	•	•
42"	96"	28 ⁷ / ₁₆ "	CRDShLB	•	•

► Specification Information, on next page

► **Specification Information, continued from previous page**

Specification Information

• Dimensions			• Style • Number	• LPL Case • with • Headset	• LPL Case • with HPL • Headset	• HPL Case • with • Headset
• Modular • Depth	• Modular • Width	• Modular • Height				

Bow-Front Desks—Single Pedestal, Right-Hand

36"	66"	28 ⁷ / ₁₆ "	CRDSKBSPR	•	•	•
36"	72"	28 ⁷ / ₁₆ "	CRDSKBSPR	•	•	•
42"	66"	28 ⁷ / ₁₆ "	CRDSKBSPR	•	•	•
42"	72"	28 ⁷ / ₁₆ "	CRDSKBSPR	•	•	•

Bow-Front Desks—Single Pedestal, Left-Hand

36"	66"	28 ⁷ / ₁₆ "	CRDSKBSPL	•	•	•
36"	72"	28 ⁷ / ₁₆ "	CRDSKBSPL	•	•	•
42"	66"	28 ⁷ / ₁₆ "	CRDSKBSPL	•	•	•
42"	72"	28 ⁷ / ₁₆ "	CRDSKBSPL	•	•	•

Bow-Front Desks—Double Pedestal

36"	66"	28 ⁷ / ₁₆ "	CRDSKBDP	•	•	•
36"	72"	28 ⁷ / ₁₆ "	CRDSKBDP	•	•	•
42"	66"	28 ⁷ / ₁₆ "	CRDSKBDP	•	•	•
42"	72"	28 ⁷ / ₁₆ "	CRDSKBDP	•	•	•

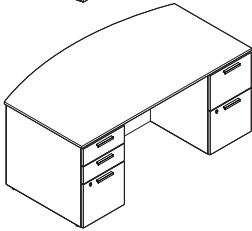
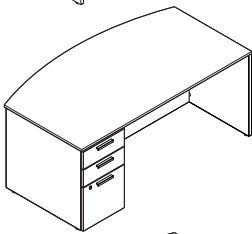
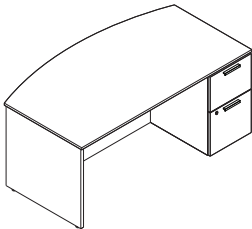

Currency Extended Curved Corner Desk Shells

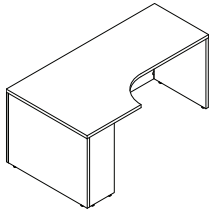

Left-Hand Unit

	Standard Includes	Required to Specify
▶ See <i>Currency Specification Guide</i> for product details.	<ul style="list-style-type: none"> • 1 1/8" thick worksurface: Low-Pressure Laminate • Desk shell with full-height modesty panel and one full-depth and one clear-access end panel <ul style="list-style-type: none"> – Low-Pressure Laminate case with matching or contrasting Low-Pressure Laminate top – Low-Pressure Laminate case with High-Pressure Laminate top, if selected – High-Pressure Laminate case with matching or contrasting High-Pressure Laminate top, if selected • 3 mm radius profile edge on user's side: plastic • 1 mm side and back edges: plastic default to match user's side • 1 1/4" adjustable leveling glides • Shipped ready to assemble 	<ol style="list-style-type: none"> 1 Style number 2 Depth (see below under Required Selections) 3 Width (see below under Required Selections) 4 Low-Pressure Laminate or High-Pressure Laminate color number for worksurface 5 Plastic color number for all edges on laminate worksurface 6 Low-Pressure Laminate or High-Pressure Laminate color number for case 7 Right and left end panels, if selected (see below under Required Selections) 8 Options, if selected (see below) <p>▶ See <i>Surface Materials</i>, page 480.</p>

	Required Selections	Required to Specify
Depth Left	• 24"D	Specify 24" depth left.
Depth Right	• 24"D	Specify 24" depth right.
Width Right	<ul style="list-style-type: none"> • 36"W • 48"W • 66"W • 72"W 	Specify 36" width right. Specify 48" width right. Specify 66" width right. Specify 72" width right.
Width Left	<ul style="list-style-type: none"> • 36"W • 48"W • 66"W • 72"W 	Specify 36" width left. Specify 48" width left. Specify 66" width left. Specify 72" width left.
Support Right	<ul style="list-style-type: none"> • Full depth end panel • Clear-access end panel 	Specify <i>with full depth end panel</i> . Specify <i>with clear-access end panel</i> .
Support Left	<ul style="list-style-type: none"> • Full depth end panel • Clear-access end panel 	Specify <i>with full depth end panel</i> . Specify <i>with clear-access end panel</i> .

Tip: Desks with a clear-access end panel cannot be freestanding.

	Options	Required to Specify
Surface Materials	Top	
	<ul style="list-style-type: none"> • Low-Pressure Laminate (LPL) price group 1 • High-Pressure Laminate (HPL) price group 1 • High-Pressure Laminate (HPL) price group 3 	Specify laminate color number. Specify laminate color number. Specify laminate color number.
Modesty Panel	Case	
	<ul style="list-style-type: none"> • Low-Pressure Laminate (LPL) price group 1 • High-Pressure Laminate (HPL) price group 1 • High-Pressure Laminate (HPL) price group 3 	Specify laminate color number. Specify laminate color number. Specify laminate color number.
Modesty Panel	<ul style="list-style-type: none"> • Full • Quarter-height 	Specify <i>with full modesty panel</i> . Specify <i>with quarter-height modesty panel</i>
Grommet	<ul style="list-style-type: none"> • No grommet • Grommet 	Specify <i>with no grommet</i> . Specify <i>with left grommet</i> .

Tip: Grain direction of extended modesty panels runs horizontally. Grain direction of shorter modesty panel and end panels run vertically.

Tip: The quarter-height modesty panel is available only on the 66" or 72" side of desk shell.

Specification Information

• Dimensions					• Style • Number	• LPL • Case	• HPL • Case
• Depth • Left	• Depth • Right	• Width • Left	• Width • Right	• Modular • Height			
•	•	•	•	•			

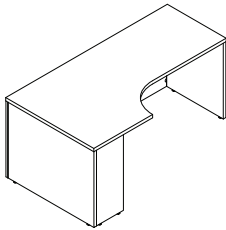

Desk—Extended Curved Corner, Left-Hand

24"	24"	66"	36"	28 ⁷ / ₁₆ "	CRDSKEL	•	•
24"	24"	66"	48"	28 ⁷ / ₁₆ "	CRDSKEL	•	•
24"	24"	72"	36"	28 ⁷ / ₁₆ "	CRDSKEL	•	•
24"	24"	72"	48"	28 ⁷ / ₁₆ "	CRDSKEL	•	•
•	•	•	•	•	•	•	•

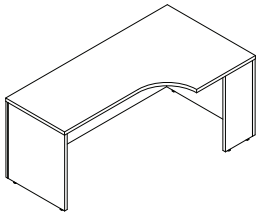

Desk—Extended Curved Corner, Right-Hand

24"	24"	36"	66"	28 ⁷ / ₁₆ "	CRDSKER	•	•
24"	24"	48"	66"	28 ⁷ / ₁₆ "	CRDSKER	•	•
24"	24"	36"	72"	28 ⁷ / ₁₆ "	CRDSKER	•	•
24"	24"	48"	72"	28 ⁷ / ₁₆ "	CRDSKER	•	•
•	•	•	•	•	•	•	•

Currency Curved Corner Desk Shells

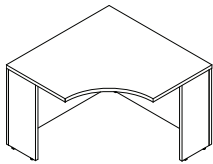

Tip: Curved corner desk shell must be used in conjunction with returns or return shells; they are not freestanding.

	Standard Includes	Required to Specify
▶ See <i>Currency Specification Guide</i> for product details.	<ul style="list-style-type: none"> • 1 1/8" thick worksurface: Low-Pressure Laminate • Desk shell with full-height modesty panel and one full-depth and two clear-access end panels (corner) <ul style="list-style-type: none"> – Low-Pressure Laminate case with matching or contrasting Low-Pressure Laminate top – Low-Pressure Laminate case with High-Pressure Laminate top, if selected – High-Pressure Laminate case with matching or contrasting High-Pressure Laminate top, if selected • 3 mm radius profile edge on user's side: plastic • 1 mm side and back edges: plastic default to match user's side • Two clear-access end panels • Full modesty panel • 1 1/4" adjustable leveling glides • Shipped ready to assemble 	<ol style="list-style-type: none"> 1 Style number 2 Low-Pressure Laminate or High-Pressure Laminate color number for worksurface 3 Plastic color number for all edges on laminate worksurface 4 Low-Pressure Laminate or High-Pressure Laminate color number for case 5 Options, if selected (see below) <ul style="list-style-type: none"> ▶ See <i>Surface Materials</i>, page 480.

	Options	Required to Specify
Surface Materials	Case <ul style="list-style-type: none"> • Low-Pressure Laminate (LPL) price group 1 • High-Pressure Laminate (HPL) price group 1 • High-Pressure Laminate (HPL) price group 3 	Specify laminate color number. Specify laminate color number. Specify laminate color number.
	Top <ul style="list-style-type: none"> • Low-Pressure Laminate (LPL) price group 1 • High-Pressure Laminate (HPL) price group 1 • High-Pressure Laminate (HPL) price group 3 	Specify laminate color number. Specify laminate color number. Specify laminate color number.
	Grommet <ul style="list-style-type: none"> • No grommet • Grommet 	Specify <i>with no grommet</i> . Specify <i>with grommet</i> .

Specification Information							
• Dimensions					• Style Number	• LPL Case	• HPL Case
• Depth Left	• Depth Right	• Width Left	• Width Right	• Modular Height			
24"	24"	42"	42"	28 7/16"	CRDSKCC	•	•
:	:	:	:	:	:	:	:

Currency Return Shells and Returns with Pedestals

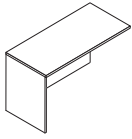

Tip: The actual thickness between Low-Pressure Laminate (LPL) and High-Pressure Laminate (HPL) worksurfaces is slightly different. It is recommended that only worksurfaces of the same type are specified in a given application. In addition, there may be sheen or texture differences when using LPL and HPL in adjacent applications.

	Standard Includes	Required to Specify
▶ See <i>Currency Specification Guide</i> for product details.	<ul style="list-style-type: none"> • 28⁷/₁₆"H return and return shells: <ul style="list-style-type: none"> – Low-Pressure Laminate case with matching or contrasting Low-Pressure Laminate headset – Low-Pressure Laminate case with High-Pressure Laminate headset, if selected – High-Pressure Laminate case with matching or contrasting High-Pressure Laminate headset, if selected • 1¹/₈" thick top: <ul style="list-style-type: none"> – Low-Pressure Laminate price group 1 – High-Pressure Laminate price group 1, if selected • 3 mm edgeband on user's side: plastic price group 1 • 1 mm edgeband on sides and back: plastic price group 1 • Finished back • Modesty panel, full or quarter height • Bore and dowel drawer construction: black • One fastened plastic filing system per file drawer: black only • Full extension, heavy-duty ball bearing drawer suspensions • Lock plug • Attachment hardware • 1¹/₄" adjustable leveling glides • Returns shipped fully assembled • Return shells shipped ready to assemble 	<ol style="list-style-type: none"> 1 Style number 2 Worksurface size type (see below under Required Selections) 3 Depth (see below under Required Selections) 4 Width (see below under Required Selections) 5 Low-Pressure Laminate or High-Pressure Laminate color number for worksurface 6 Plastic color number for all edges on laminate worksurface 7 Low-Pressure Laminate or High-Pressure Laminate color number for case 8 Low-Pressure Laminate or High-Pressure Laminate color number for headset 9 Pulls, if selected (see below under Required Selections) 10 Right and left support pedestals, if selected (see below under Required Selections) 11 Options, if selected (see below) <ul style="list-style-type: none"> ▶ See <i>Surface Materials</i>, page 480. <i>Tip: Remember to specify lock cylinder and key.</i> ▶ <i>Lock Cylinders</i>, page 441

	Required Selections	Required to Specify
Size Type	• Modular	Specify with <i>modular</i> .
Depth	• 18 ⁷ / ₈ "D • 24"D	Specify 18 ⁷ / ₈ " depth. Specify 24" depth.
Width	• 36"W • 42"W • 48"W	Specify 36" width. Specify 42" width. Specify 48" width.
Support—Right	• Box/box/file pedestal • File/file pedestal • Full depth end panel • Open/box/file pedestal	Specify with <i>box/box/file pedestal</i> . Specify with <i>file/file pedestal</i> . Specify with <i>full depth end panel</i> . Specify with <i>open/box/file pedestal</i> .
Support—Left	• Box/box/file pedestal • File/file pedestal • Full depth end panel • Open/box/file pedestal	Specify with <i>box/box/file pedestal</i> . Specify with <i>file/file pedestal</i> . Specify with <i>full depth end panel</i> . Specify with <i>open/box/file pedestal</i> .

Tip: Return with one pedestal is not available in 18⁷/₈"D or 36"W.

Tip: Lock for the box/box/file configuration does not lock the top box drawer.

Tip: Specify either a left or right support pending style number. Left-hand styles will only prompt support-left. Right-hand styles will only prompt support-right.

Pull Shape

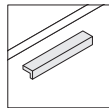

Ledge

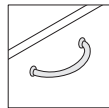

Handle

Tip: Grain direction of modesty panel runs horizontally. Grain direction of pedestals runs vertically.

Options		Required to Specify
Surface Materials	Top	
	<ul style="list-style-type: none"> Low-Pressure Laminate (LPL) price group 1 High-Pressure Laminate (HPL) price group 1 High-Pressure Laminate (HPL) price group 3 	Specify laminate color number. Specify laminate color number. Specify laminate color number.
	Case	
	<ul style="list-style-type: none"> Low-Pressure Laminate (LPL) price group 1 High-Pressure Laminate (HPL) price group 1 High-Pressure Laminate (HPL) price group 3 	Specify laminate color number. Specify laminate color number. Specify laminate color number.
	Headset	
	<ul style="list-style-type: none"> Low-Pressure Laminate (LPL) price group 1 High-Pressure Laminate (HPL) price group 1 High-Pressure Laminate (HPL) price group 3 	Specify laminate color number. Specify laminate color number. Specify laminate color number.
Pull	<ul style="list-style-type: none"> Handle Ledge 	Specify with <i>handle pull</i> . Specify with <i>ledge pull</i> .
Modesty Panel	<ul style="list-style-type: none"> Full Quarter height 	Specify with <i>full panel</i> . Specify with <i>quarter height panel</i> .
Grommet Location	<ul style="list-style-type: none"> No grommet Left Right Center Right and left Right and center Left and center Right, left, and center 	Specify with <i>no grommet</i> . Specify with <i>left grommet</i> . Specify with <i>right grommet</i> . Specify with <i>center grommet</i> . Specify with <i>right and left grommet</i> . Specify with <i>right and center grommet</i> . Specify with <i>left and center grommet</i> . Specify with <i>right, left, and center grommet</i> .
Keys	<ul style="list-style-type: none"> Key plug Master key plug 	Specify with <i>key plug</i> . Specify with <i>master key plug</i> .

Specification Information			
Dimensions		Style	Modular Depth
Modular	Height	Number	
Width			18 ⁷ / ₈ " : 24"

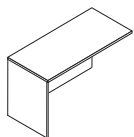

Return Shell with One Full Depth End Panel				
Left Hand, Low-Pressure Laminate Case				
36"	28 ⁷ / ₁₆ "	CRRTNL	•	•
42"	28 ⁷ / ₁₆ "	CRRTNL	•	•
48"	28 ⁷ / ₁₆ "	CRRTNL	•	•
Left Hand, High-Pressure Laminate Case				
36"	28 ⁷ / ₁₆ "	CRRTNL	•	•
42"	28 ⁷ / ₁₆ "	CRRTNL	•	•
48"	28 ⁷ / ₁₆ "	CRRTNL	•	•

► Specification Information, on next page

► **Specification Information, continued from previous page**

Specification Information			
• Dimensions		• Style	• Modular Depth
Modular Width	Height	Number	
			18 ⁷ / ₈ " : 24"

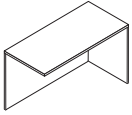

Return Shell with One Full Depth End Panel, continued

Right Hand, Low-Pressure Laminate Case					
Modular Width	Height	Style Number			
36"	28 ⁷ / ₁₆ "	CRRTNR	•	•	
42"	28 ⁷ / ₁₆ "	CRRTNR	•	•	
48"	28 ⁷ / ₁₆ "	CRRTNR	•	•	

Right Hand, High-Pressure Laminate Case					
Modular Width	Height	Style Number			
36"	28 ⁷ / ₁₆ "	CRRTNR	•	•	
42"	28 ⁷ / ₁₆ "	CRRTNR	•	•	
48"	28 ⁷ / ₁₆ "	CRRTNR	•	•	

Specification Information						
• Dimensions			• Style	• LPL Case	• LPL Case	• HPL Case
Modular Width	Height	Modular Depth	Number	with Headset	with HPL Headset	with Headset

Return with One Pedestal

Left Hand						
Modular Width	Height	Modular Depth	Style Number			
42"	28 ⁷ / ₁₆ "	24"	CRRTNSPL	•	•	•
48"	28 ⁷ / ₁₆ "	24"	CRRTNSPL	•	•	•

Right Hand						
Modular Width	Height	Modular Depth	Style Number			
42"	28 ⁷ / ₁₆ "	24"	CRRTNSPR	•	•	•
48"	28 ⁷ / ₁₆ "	24"	CRRTNSPR	•	•	•

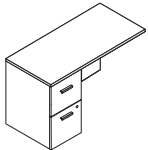

Left-hand unit

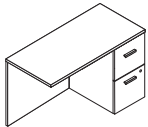

Right-hand unit

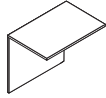

Standard Includes		Required to Specify
<ul style="list-style-type: none"> ▶ See <i>Currency Specification Guide</i> for product details. 	<ul style="list-style-type: none"> • 1¹/₈" thick top: <ul style="list-style-type: none"> – Low-Pressure Laminate case, price group 1 – High-Pressure Laminate case, price group 1, if selected • Attachment bracket • 3 mm edgeband on user's side: plastic price group 1 • 1 mm edgeband on sides and back: plastic price group 1 • Modesty panel, full or quarter height • Shipped ready to assemble 	<ol style="list-style-type: none"> 1 Style number 2 Worksurface size type (see below under Required Selections) 3 Depth (see below under Required Selections) 4 Width (see below under Required Selections) 5 Low-Pressure Laminate or High-Pressure Laminate color number for worksurface 6 Plastic color number for all edges on laminate worksurface 7 Low-Pressure Laminate or High-Pressure Laminate color number for case 8 Options, if selected (see below) <ul style="list-style-type: none"> ▶ See <i>Surface Materials</i>, page 480.

Required Selections		Required to Specify
Size Type	• Modular	Specify <i>with modular</i> .
Depth	• 18 ⁷ / ₈ "D • 24"D	Specify 18 ⁷ / ₈ " depth. Specify 24" depth.
Width	• 36"W • 42"W • 48"W	Specify 36" width. Specify 42" width. Specify 48" width.

Options		Required to Specify
Surface Materials	Top <ul style="list-style-type: none"> • Low-Pressure Laminate (LPL) price group 1 • High-Pressure Laminate (HPL) price group 1 • High-Pressure Laminate (HPL) price group 3 Case <ul style="list-style-type: none"> • Low-Pressure Laminate (LPL) price group 1 • High-Pressure Laminate (HPL) price group 1 • High-Pressure Laminate (HPL) price group 3 	Specify laminate color number. Specify laminate color number. Specify laminate color number.
Modesty Panel	• Full • Quarter height	Specify <i>with full panel</i> . Specify <i>with quarter height panel</i> .
Grommet Location	• No grommet • Center	Specify <i>with no grommet</i> . Specify <i>with center grommet</i> .

Specification Information			
Dimensions		Style	Modular Depth
Modular	Height	Number	
Width			18 ⁷ / ₈ " : 24"

Bridge

Low-Pressure Laminate Case

36"	28 ⁷ / ₁₆ "	CRBRG	•	•
42"	28 ⁷ / ₁₆ "	CRBRG	•	•
48"	28 ⁷ / ₁₆ "	CRBRG	•	•

High-Pressure Laminate Case

36"	28 ⁷ / ₁₆ "	CRBRG	•	•
42"	28 ⁷ / ₁₆ "	CRBRG	•	•
48"	28 ⁷ / ₁₆ "	CRBRG	•	•
:	:	:	:	:

Currency D-Shape and P-Shape Worksurfaces

Standard Includes		Required to Specify
<ul style="list-style-type: none"> ▶ See <i>Currency Specification Guide</i> for product details. 	<ul style="list-style-type: none"> 1 1/8" thick top: <ul style="list-style-type: none"> – Low-Pressure Laminate case with matching or contrasting Low-Pressure Laminate top – Low-Pressure Laminate case with matching or contrasting High-Pressure Laminate top, if selected – High-Pressure Laminate case with matching or contrasting Low-Pressure Laminate top, if selected – High-Pressure Laminate case with matching or contrasting High-Pressure Laminate top, if selected • Column leg: paint price group 1 • Adjusting leveling glides • Ships ready to assemble 	<ol style="list-style-type: none"> 1 Style number 2 Depth 3 Width 4 Low-Pressure Laminate or High-Pressure Laminate color number for worksurface 5 Plastic color number for all edges on laminate worksurface 6 Low-Pressure Laminate or High-Pressure Laminate color number for case 7 Paint color number for column leg 8 Options, if selected (see below) <ul style="list-style-type: none"> ▶ See <i>Surface Materials</i>, page 480.

Options		Required to Specify
Surface Materials	Case	Specify laminate color number.
	Top	Specify laminate color number.
	Base	Specify paint color number.
Modesty Panel	• No modesty panel	Specify <i>without modesty panel</i> .
	• Quarter height	Specify <i>with quarter height panel</i> .
Handedness	• Left-hand	Specify <i>with left-hand</i> .
	• Right-hand	Specify <i>with right-hand</i> .

Tip: Right-hand P-shape worksurfaces pair with left-hand returns. Left-hand P-shape worksurfaces pair with right-hand returns.

Specification Information							
Style Number	Dimensions Modular Depth	Modular Width					
		48"W	54"W	60"W	66"W	72"W	78"W
•	•	•	•	•	•	•	•
•	•	•	•	•	•	•	•

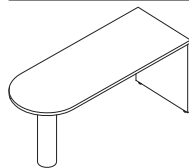

D-Shape, Low-Pressure Laminate Case and Top

CRDWKSF	30"	•	•	•	•	•	•
	36"	•	•	•	•	•	•
		•	•	•	•	•	•

D-Shape, High-Pressure Laminate Case and Top

CRDWKSF	30"	•	•	•	•	•	•
	36"	•	•	•	•	•	•
		•	•	•	•	•	•

▶ Specification Information, continued on next page

► **Specification Information, continued from previous page**

Specification Information							
Style Number	Dimensions Modular Depth	Modular Width					
		48"W	54"W	60"W	66"W	72"W	78"W

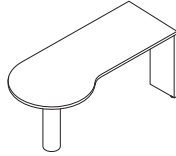

Right-hand unit

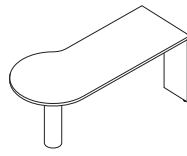

Left-hand unit

P-Shape, Low-Pressure Laminate Case and Top

CRPWKSF	Dimensions	48"W	54"W	60"W	66"W	72"W	78"W
	24"	N.A.	•	•	•	•	N.A.
	30"	N.A.	•	•	•	•	N.A.
	36"	N.A.	•	•	•	•	N.A.

P-Shape, High-Pressure Laminate Case and Top

CRPWKSF	Dimensions	48"W	54"W	60"W	66"W	72"W	78"W
	24"	N.A.	•	•	•	•	N.A.
	30"	N.A.	•	•	•	•	N.A.
	36"	N.A.	•	•	•	•	N.A.

Currency Parametric Common Tops HAD Application

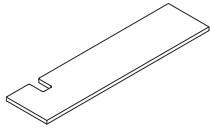

Right-hand unit

Standard Includes	Required to Specify
<ul style="list-style-type: none"> ▶ See <i>Currency Specification Guide</i> for product details. • 1/8" thick common top for Ology, Migration SE, and Slim Leg HAD application: <ul style="list-style-type: none"> – Low-Pressure Laminate price group 1 – High-Pressure Laminate price group 1, if selected • 3 mm edgeband on user's side: plastic price group 1 • 1 mm edgeband on sides and back: plastic price group 1 • Width: 30"W–96"W (LPL), 30"W–96"W (HPL) • Depth: 18 7/8"D–24"D (LPL and HPL) 	<ol style="list-style-type: none"> 1 Style number 2 Worksurface size type (see below under Required Selections) 3 Depth (see below under Required Selections) 4 Width (see below under Required Selections) 5 Desk type (see below under Required Selections) 6 Handedness (see below under Required Selections) 7 Desk depth (see below under Required Selections) <p>▶ See <i>Surface Materials</i>, page 480.</p>

Required Selections	Required to Specify
Depth <ul style="list-style-type: none"> • 18 7/8"D • 24"D 	Specify 18 7/8" depth. Specify 24" depth.
Desk Type <ul style="list-style-type: none"> • Migration SE • Ology • Slim Leg HAD 	Specify with <i>Migration SE</i> . Specify with <i>Ology</i> . Specify with <i>Slim Leg HAD</i> .
Desk Depth <ul style="list-style-type: none"> • 23"D • 28"D • 29"D • 30"D • 34"D • 35"D • 36"D 	Specify 23" desk depth. Specify 28" desk depth. Specify 29" desk depth. Specify 30" desk depth. Specify 34" desk depth. Specify 35" desk depth. Specify 36" desk depth.
Handedness <ul style="list-style-type: none"> • Left-hand • Right-hand 	Specify with <i>left-hand</i> . Specify with <i>right-hand</i> .
Leg Type <ul style="list-style-type: none"> • C leg • T leg 	Specify with <i>C leg</i> . Specify with <i>T leg</i> .

Tip: Right-hand or left-hand application is determined by which leg of the Ology desk is located inside the storage.

Tip: The actual thickness between Low-Pressure Laminate (LPL) and High-Pressure Laminate (HPL) worksurfaces is slightly different. It is recommended that only worksurfaces of the same type are specified in a given application. In addition, there may be sheen or texture differences when using LPL and HPL in adjacent applications.

Options	Required to Specify
Surface Materials <ul style="list-style-type: none"> • Top • Low-Pressure Laminate (LPL) price group 1 • High-Pressure Laminate (HPL) price group 1 	Specify laminate color number. Specify laminate color number.

Specification Information

Style Number	Width	Modular Depth	
		18 ⁷ / ₈ "D	24"D

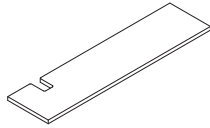

Right-hand unit

Common Tops HAD Application—Low-Pressure Laminate

CRHADCT	Width	Modular Depth	Modular Depth
	30"	•	•
	36"	•	•
	42"	•	•
	48"	•	•
	54"	•	•
	60"	•	•
	66"	•	•
	72"	•	•
	78"	•	•
	84"	•	•
	90"	•	•
	96"	•	•
	102"	N.A.	N.A.
	108"	N.A.	N.A.
	114"	N.A.	N.A.
	120"	N.A.	N.A.

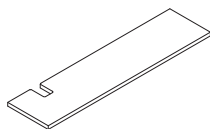

Right-hand unit

Common Tops HAD Application—High-Pressure Laminate

CRHADCT	Width	Modular Depth	Modular Depth
	30"	•	•
	36"	•	•
	42"	•	•
	48"	•	•
	54"	•	•
	60"	•	•
	66"	•	•
	72"	•	•
	78"	•	•
	84"	•	•
	90"	•	•
	96"	•	•
	102"	N.A.	N.A.
	108"	N.A.	N.A.
	114"	N.A.	N.A.
	120"	N.A.	N.A.

Currency Parametric Common Tops/Worksurfaces

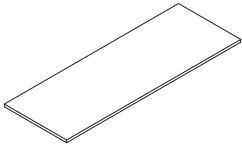

Tip: When specifying a Currency parametric common top over a run of storage, use SmartTools to determine the correct dimension to be specified.

▶ See *Currency Specification Guide*.

Tip: Worksurfaces being used as a table, up to 84"W, require four legs and appropriate reinforcing channels. Worksurfaces 84¹/₁₆"W–96"W require six legs and appropriate reinforcing channels.

Tip: Reinforcing channels are ordered separately and must be used with tops larger than 54"W for 54"W or more of unsupported kneespace.

Tip: Any top used as a table with legs, equal to or larger than 30"Dx72"W requires two reinforcing channels.

Tip: The actual thickness between Low-Pressure Laminate (LPL) and High-Pressure Laminate (HPL) worksurfaces is slightly different. It is recommended that only worksurfaces of the same type are specified in a given application. In addition, there may be sheen or texture differences when using LPL and HPL in adjacent applications.

Tip: Width is specifiable in ¹/₁₆" increments.

Standard Includes	Required to Specify
<ul style="list-style-type: none"> ▶ See <i>Currency Specification Guide</i> for product details. • ¹/₈" thick common top: <ul style="list-style-type: none"> – Low-Pressure Laminate price group 1 – High-Pressure Laminate price group 1, if selected • 3 mm edgeband on user's side: plastic price group 1 • 1 mm edgeband on sides and back: plastic price group 1 	<ol style="list-style-type: none"> 1 Style number 2 Depth (see below under Required Selections) 3 Width (see below under Required Selections) 4 Low-Pressure Laminate or High-Pressure Laminate color number for worksurface 5 Plastic color number for all edges on laminate worksurface 6 Options, if selected (see below) <p>▶ See <i>Surface Materials</i>, page 480.</p>

	Required Selections	Required to Specify
Depth	• 12"D–36"D	Specify 12"–36" depth.
Width	• 15"W–96"W	Specify 15"–96" width.

	Options	Required to Specify
Surface Materials	Top <ul style="list-style-type: none"> • Low-Pressure Laminate (LPL) price group 1 • High-Pressure Laminate (HPL) price group 1 • High-Pressure Laminate (HPL) price group 3 	Specify laminate color number. Specify laminate color number. Specify laminate color number.

Grommet Location	<ul style="list-style-type: none"> • No grommet • Left • Right • Center • Right and center • Left and center • Right, left, and center 	Specify <i>with no grommet</i> . Specify <i>with left grommet</i> . Specify <i>with right grommet</i> . Specify <i>with center grommet</i> . Specify <i>with right and center grommet</i> . Specify <i>with left and center grommet</i> . Specify <i>with right, left, and center grommet</i> .
-------------------------	---	---

Specification Information								
Style Number	Dimensions		Modular Depth	12"D	18 ⁷ / ₁₆ "D	24"D	30"D	36"D
	Width	Parametric Width		12"D— 17 ¹⁵ / ₁₆ "D	18"D— 23 ¹⁵ / ₁₆ "D	24"D— 29 ¹⁵ / ₁₆ "D	30"D— 35 ¹⁵ / ₁₆ "D	36"D

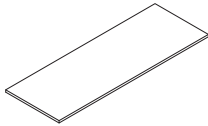

Parametric Common Tops/Worksurface—Low-Pressure Laminate

CRCT	15"	15"—17 ¹⁵ / ₁₆ "	•	•	•	•	•
	18"	18"—23 ¹⁵ / ₁₆ "	•	•	•	•	•
	24"	24"—29 ¹⁵ / ₁₆ "	•	•	•	•	•
	30"	30"—35 ¹⁵ / ₁₆ "	•	•	•	•	•
	36"	36"—41 ¹⁵ / ₁₆ "	•	•	•	•	•
	42"	42"—47 ¹⁵ / ₁₆ "	•	•	•	•	•
	48"	48"—53 ¹⁵ / ₁₆ "	•	•	•	•	•
	54"	54"—59 ¹⁵ / ₁₆ "	•	•	•	•	•
	60"	60"—65 ¹⁵ / ₁₆ "	•	•	•	•	•
	66"	66"—71 ¹⁵ / ₁₆ "	•	•	•	•	•
	72"	72"—77 ¹⁵ / ₁₆ "	•	•	•	•	•
	78"	78"—83 ¹⁵ / ₁₆ "	•	•	•	•	•
	84"	84"—89 ¹⁵ / ₁₆ "	•	•	•	•	•
	90"	90"—95 ¹⁵ / ₁₆ "	•	•	•	•	•
	96"	96"—101 ¹⁵ / ₁₆ "	•	•	•	•	•

Parametric Common Tops/Worksurface—High-Pressure Laminate

CRCT	15"	15"—17 ¹⁵ / ₁₆ "	•	•	•	•	•
	18"	18"—23 ¹⁵ / ₁₆ "	•	•	•	•	•
	24"	24"—29 ¹⁵ / ₁₆ "	•	•	•	•	•
	30"	30"—35 ¹⁵ / ₁₆ "	•	•	•	•	•
	36"	36"—41 ¹⁵ / ₁₆ "	•	•	•	•	•
	42"	42"—47 ¹⁵ / ₁₆ "	•	•	•	•	•
	48"	48"—53 ¹⁵ / ₁₆ "	•	•	•	•	•
	54"	54"—59 ¹⁵ / ₁₆ "	•	•	•	•	•
	60"	60"—65 ¹⁵ / ₁₆ "	•	•	•	•	•
	66"	66"—71 ¹⁵ / ₁₆ "	•	•	•	•	•
	72"	72"—77 ¹⁵ / ₁₆ "	•	•	•	•	•
	78"	78"—83 ¹⁵ / ₁₆ "	•	•	•	•	•
	84"	84"—89 ¹⁵ / ₁₆ "	•	•	•	•	•
	90"	90"—95 ¹⁵ / ₁₆ "	•	•	•	•	•
	96"	96"—101 ¹⁵ / ₁₆ "	•	•	•	•	•

Currency Modesty Panel



Standard Includes	Required to Specify
<ul style="list-style-type: none"> Modesty panel: Low-Pressure Laminate price group 1 Bracket: merle paint Ships ready to assemble 	<ol style="list-style-type: none"> Style number Low-Pressure Laminate color number for modesty panel Options, if selected (see below) <ul style="list-style-type: none"> ▶ See <i>Surface Materials</i>, page 480.

Options	Required to Specify
Surface Materials <ul style="list-style-type: none"> Modesty panel Low-Pressure Laminate (LPL) price group 1 High-Pressure Laminate (HPL) price group 1 High-Pressure Laminate (HPL) price group 3 	Specify laminate color number. Specify laminate color number. Specify laminate color number.

Specification Information									
Style Number	Height	Modular Width	24"W	30"W	36"W	42"W	48"W	54"W	60"W
		Parametric Width	24"W–29 ¹⁵ / ₁₆ "W	30"W–35 ¹⁵ / ₁₆ "W	36"W–41 ¹⁵ / ₁₆ "W	42"W–47 ¹⁵ / ₁₆ "W	48"W–53 ¹⁵ / ₁₆ "W	54"W–59 ¹⁵ / ₁₆ "W	60"W

Low-Pressure Laminate

CRMP	13 ³ / ₄ "	•	•	•	•	•	•	•	•
------	----------------------------------	---	---	---	---	---	---	---	---

High-Pressure Laminate

CRMP	13 ³ / ₄ "	•	•	•	•	•	•	•	•
------	----------------------------------	---	---	---	---	---	---	---	---

Currency 1.5-High and Two-High Fixed Pedestals

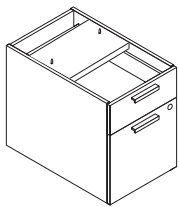

► See *Currency Specification Guide* for product details.

Standard Includes

- Fixed pedestal, 1.5-High and Two-High:
 - Low-Pressure Laminate case with matching or contrasting Low-Pressure Laminate headset
 - Low-Pressure Laminate case with High-Pressure Laminate headset, if selected
 - High-Pressure Laminate case with matching or contrasting High-Pressure Laminate headset, if selected
- Finished back
- Bore and dowel drawer construction: black
- One fastened plastic filing system per file drawer: black only
- Full extension, heavy-duty ball bearing drawer suspensions
- One pencil tray is included in units with a box drawer
- Lock plug
- Attachment hardware
- 1¼" adjustable leveling glides
- Shipped fully assembled

Required to Specify

- 1 Style number
- 2 Size type (see below under Required Selections)
- 3 Depth (see below under Required Selections)
- 4 Low-Pressure Laminate or High-Pressure Laminate color number for case
- 5 Low-Pressure Laminate or High-Pressure Laminate color number for headset
- 6 Pulls (see below under Required Selections)
- 7 Options, if selected (see below)
 - See *Surface Materials*, page 480.
 - Tip: Remember to specify lock cylinder and key.*
 - *Lock Cylinders*, page 441

Required Selections		Required to Specify
Size Type	• Modular	Specify <i>with modular</i> .
Depth	• 18 ⁷ / ₈ "D • 24"D • 30"D	Specify 18 ⁷ / ₈ " depth. Specify 24" depth. Specify 30" depth.

Pull Shape

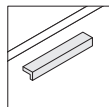

Ledge

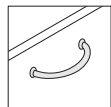

Handle

Options		Required to Specify
Surface Materials	Case	Specify laminate color number. Specify laminate color number. Specify laminate color number.
	• Low-Pressure Laminate (LPL) price group 1 • High-Pressure Laminate (HPL) price group 1 • High-Pressure Laminate (HPL) price group 3	
	Headset	Specify laminate color number. Specify laminate color number. Specify laminate color number.
	• Low-Pressure Laminate (LPL) price group 1 • High-Pressure Laminate (HPL) price group 1 • High-Pressure Laminate (HPL) price group 3	
Pull	• Handle • Ledge	Specify <i>with handle pull</i> . Specify <i>with ledge pull</i> .
Counterweight	• No counterweight • With counterweight	Specify <i>with no counterweight</i> . Specify <i>with counterweight</i> .
Keys	• Key plug • Master key plug	Specify <i>with key plug</i> . Specify <i>with master key plug</i> .

Tip: Lock for the box/box/file configuration does not lock the top box drawer.

Specification Information

Dimensions			Style Number	LPL Case		HPL Case
D	W	H		LPL	HPL	HPL
Modular				Headset	Headset	Headset

1.5-High Fixed Pedestals

One Box Drawer and One File Drawer

18 ⁷ / ₈ "	15 ³ / ₄ "	21 ³ / ₈ "	CRPD15H	•	•	•
24"	15 ³ / ₄ "	21 ³ / ₈ "	CRPD15H	•	•	•

Two-High Fixed Pedestals

One Open, One Box Drawer, and One File Drawer

18 ⁷ / ₈ "	15 ³ / ₄ "	27 ⁵ / ₁₆ "	CRPD2H0BF	•	•	•
24"	15 ³ / ₄ "	27 ⁵ / ₁₆ "	CRPD2H0BF	•	•	•
30"	15 ³ / ₄ "	27 ⁵ / ₁₆ "	CRPD2H0BF	•	•	•

Two Box Drawers and One File Drawer

18 ⁷ / ₈ "	15 ³ / ₄ "	27 ⁵ / ₁₆ "	CRPD2HBBF	•	•	•
24"	15 ³ / ₄ "	27 ⁵ / ₁₆ "	CRPD2HBBF	•	•	•
30"	15 ³ / ₄ "	27 ⁵ / ₁₆ "	CRPD2HBBF	•	•	•

Two File Drawers

18 ⁷ / ₈ "	15 ³ / ₄ "	27 ⁵ / ₁₆ "	CRPD2HFF	•	•	•
24"	15 ³ / ₄ "	27 ⁵ / ₁₆ "	CRPD2HFF	•	•	•
30"	15 ³ / ₄ "	27 ⁵ / ₁₆ "	CRPD2HFF	•	•	•

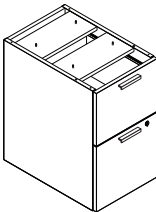
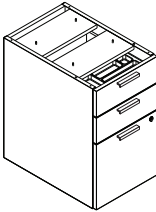
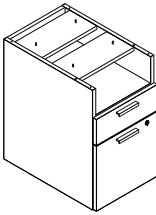
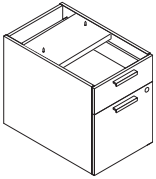

Currency Two-High Fixed Pedestals for Use with Shells

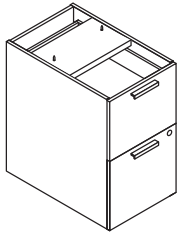

▶ See *Currency Specification Guide* for product details.

Standard Includes

- Fixed pedestal, Two-High:
 - Low-Pressure Laminate case with matching or contrasting Low-Pressure Laminate headset
 - Low-Pressure Laminate case with High-Pressure Laminate headset, if selected
 - High-Pressure Laminate case with matching or contrasting High-Pressure Laminate headset, if selected
- Finished back
- Bore and dowel drawer construction: black
- One fastened plastic filing system per file drawer: black only
- Full extension, heavy-duty ball bearing drawer suspensions
- One pencil tray is included in units with a box drawer
- Lock plug
- Attachment hardware
- 1 1/4" adjustable leveling glides
- Shipped fully assembled

Required to Specify

- 1 Style number
 - 2 Size type (see below under Required Selections)
 - 3 Application (see below under Required Selections)
 - 4 Application depth (see below under Required Selections)
 - 5 Low-Pressure Laminate or High-Pressure Laminate color number for case
 - 6 Low-Pressure Laminate or High-Pressure Laminate color number for headset
 - 7 Pulls (see below under Required Selections)
 - 8 Options, if selected (see below)
- ▶ See *Surface Materials*, page 480.
Tip: Remember to specify lock cylinder and key.
 ▶ *Lock Cylinders*, page 441

Tip: Specify type of Currency shell the pedestal will be going underneath in application step.

Tip: Specify depth of your Currency shell the pedestal will be going underneath in application depth step.

Required Selections

- | Size Type | Application |
|-----------|--|
| • Modular | <ul style="list-style-type: none"> • Currency desk shell • Currency bow front shell • Currency desk shell with overhang |
| | <ul style="list-style-type: none"> • Currency return shell • Currency extended curved corner shell |

- | Application Depth |
|--|
| <ul style="list-style-type: none"> • 18 7/8"D • 24"D • 30"D • 36"D • 42"D |

Required to Specify

- Specify *with modular*.
- Specify *with Currency desk shell*.
 Specify *with Currency bow front shell*.
 Specify *with Currency desk shell with overhang*.
 Specify *with Currency return shell*.
 Specify *with Currency extended curved corner shell*.

- Specify 18 7/8" depth.
 Specify 24" depth.
 Specify 30" depth.
 Specify 36" depth.
 Specify 42" depth.

Pull Shape

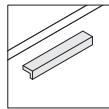

Ledge

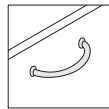

Handle

Options

Surface Materials

- Case**
- Low-Pressure Laminate (LPL) price group 1
 - High-Pressure Laminate (HPL) price group 1
 - High-Pressure Laminate (HPL) price group 3

- Headset**
- Low-Pressure Laminate (LPL) price group 1
 - High-Pressure Laminate (HPL) price group 1
 - High-Pressure Laminate (HPL) price group 3

- Pull**
- Handle
 - Ledge

- Counterweight**
- No counterweight
 - With counterweight

- Keys**
- Key plug
 - Master key plug

Required to Specify

- Specify laminate color number.
 Specify laminate color number.
 Specify laminate color number.

- Specify laminate color number.
 Specify laminate color number.
 Specify laminate color number.

- Specify *with handle pull*.
 Specify *with ledge pull*.

- Specify *with no counterweight*.
 Specify *with counterweight*.

- Specify *with key plug*.
 Specify *with master key plug*.

Tip: Lock for the box/box/file configuration does not lock the top box drawer.

Specification Information

Dimensions			Style Number	LPL Case		HPL Case
D	W	H		LPL Case	HPL Case	
Modular				LPL Headset	HPL Headset	HPL Headset

Two-High Fixed Pedestals For Use with Shells

One Open, One Box Drawer, and One File Drawer

18 ⁷ / ₈ "	15 ³ / ₄ "	27 ⁵ / ₁₆ "	CRPDSHL2HOBF	•	•	•
24"	15 ³ / ₄ "	27 ⁵ / ₁₆ "	CRPDSHL2HOBF	•	•	•
30"	15 ³ / ₄ "	27 ⁵ / ₁₆ "	CRPDSHL2HOBF	•	•	•
36"	15 ³ / ₄ "	27 ⁵ / ₁₆ "	CRPDSHL2HOBF	•	•	•
42"	15 ³ / ₄ "	27 ⁵ / ₁₆ "	CRPDSHL2HOBF	•	•	•

Two Box Drawers and One File Drawer

18 ⁷ / ₈ "	15 ³ / ₄ "	27 ⁵ / ₁₆ "	CRPDSHL2HBBF	•	•	•
24"	15 ³ / ₄ "	27 ⁵ / ₁₆ "	CRPDSHL2HBBF	•	•	•
30"	15 ³ / ₄ "	27 ⁵ / ₁₆ "	CRPDSHL2HBBF	•	•	•
36"	15 ³ / ₄ "	27 ⁵ / ₁₆ "	CRPDSHL2HBBF	•	•	•
42"	15 ³ / ₄ "	27 ⁵ / ₁₆ "	CRPDSHL2HBBF	•	•	•

Two File Drawers

18 ⁷ / ₈ "	15 ³ / ₄ "	27 ⁵ / ₁₆ "	CRPDSHL2HFF	•	•	•
24"	15 ³ / ₄ "	27 ⁵ / ₁₆ "	CRPDSHL2HFF	•	•	•
30"	15 ³ / ₄ "	27 ⁵ / ₁₆ "	CRPDSHL2HFF	•	•	•
36"	15 ³ / ₄ "	27 ⁵ / ₁₆ "	CRPDSHL2HFF	•	•	•
42"	15 ³ / ₄ "	27 ⁵ / ₁₆ "	CRPDSHL2HFF	•	•	•

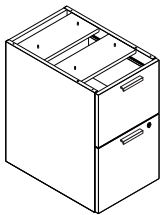
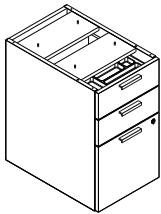
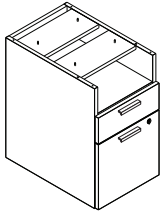

Currency Mobile Pedestals

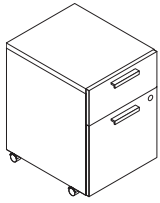

	Standard Includes	Required to Specify
<p>▶ See <i>Currency Specification Guide</i> for product details.</p>	<ul style="list-style-type: none"> Mobile pedestal, 1.5 High, and Two-High: <ul style="list-style-type: none"> Low-Pressure Laminate case with matching or contrasting Low-Pressure Laminate headse Low-Pressure Laminate case with High-Pressure Laminate headset, if selected High-Pressure Laminate case with matching or contrasting High-Pressure Laminate headset, if selected Finished back Bore and dowel drawer construction: black One fastened plastic filing system per file drawer: black only Full extension, heavy-duty ball bearing drawer suspensions Two counterweights Lock plug Ships partially assembled, casters to be added in the field One pencil tray is included in units with a box drawer 	<ol style="list-style-type: none"> Style number Size type (see below under Required Selections) Depth (see below under Required Selections) Low-Pressure Laminate or High-Pressure Laminate color number for case Low-Pressure Laminate or High-Pressure Laminate color number for headset Low-Pressure Laminate or High-Pressure Laminate color number for top Plastic color number for all edges on laminate top Pulls (see below under Required Selections) Options, if selected (see below) <p>▶ See <i>Surface Materials</i>, page 480. Tip: Remember to specify lock cylinder and key. ▶ <i>Lock Cylinders</i>, page 441</p>

	Required Selections	Required to Specify
Size Type	<ul style="list-style-type: none"> Modular 	Specify with modular.
Depth	<ul style="list-style-type: none"> 18⁷/₈"D 22"D 	Specify 18 ⁷ / ₈ " depth. Specify 22" depth.

Pull Shape

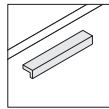

Ledge

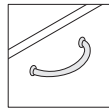

Handle

	Options	Required to Specify
Surface Materials	<p>Case</p> <ul style="list-style-type: none"> Low-Pressure Laminate (LPL) price group 1 High-Pressure Laminate (HPL) price group 1 High-Pressure Laminate (HPL) price group 3 <p>Headset</p> <ul style="list-style-type: none"> Low-Pressure Laminate (LPL) price group 1 High-Pressure Laminate (HPL) price group 1 High-Pressure Laminate (HPL) price group 3 <p>Top</p> <ul style="list-style-type: none"> Low-Pressure Laminate (LPL) price group 1 High-Pressure Laminate (HPL) price group 1 High-Pressure Laminate (HPL) price group 3 <p>Cushion</p> <ul style="list-style-type: none"> Fabric price group 1 Fabric price group 2 Fabric price group 3 Fabric price group 5 Fabric price group 6 	<p>Specify laminate color number. Specify laminate color number. Specify laminate color number.</p> <p>Specify laminate color number. Specify laminate color number. Specify laminate color number.</p> <p>Specify laminate color number. Specify laminate color number. Specify laminate color number.</p> <p>Specify fabric color number. Specify fabric color number. Specify fabric color number. Specify fabric color number. Specify fabric color number.</p>
Pull	<ul style="list-style-type: none"> Handle Ledge 	Specify with handle pull. Specify with ledge pull.
Drawer Configuration	<ul style="list-style-type: none"> Box/box/file Box/file Open/box/file 	Specify with box/box/file. Specify with box/file. Specify with open/box/file.
Keys	<ul style="list-style-type: none"> Key plug Master key plug 	Specify with key plug. Specify with master key plug.

Tip: Lock for the box/box/file configuration does not lock the top box drawer.

Specification Information

Dimensions			Style Number	LPL Case			HPL Case	
D	W	H		LPL Headset and Top	HPL Headset with LPL Top	HPL Headset and Top	HPL Headset with LPL Top	HPL Headset and Top

1.5-High Mobile Pedestals

One Box Drawer and One File Drawer

18 ⁷ / ₈ "	15 ³ / ₄ "	23 ² / ₃ "	CRMP15H	•	•	•	•	•
22"	15 ³ / ₄ "	23 ² / ₃ "	CRMP15H	•	•	•	•	•

Two-High Mobile Pedestals

One Open, One Box Drawer, and One File Drawer

22"	15 ³ / ₄ "	27 ³ / ₃₂ "	CRMP2H0BF	•	•	•	•	•
-----	----------------------------------	-----------------------------------	------------------	---	---	---	---	---

Two Box Drawers and One File Drawer

22"	15 ³ / ₄ "	27 ³ / ₃₂ "	CRMP2HBBF	•	•	•	•	•
-----	----------------------------------	-----------------------------------	------------------	---	---	---	---	---

Two File Drawers

22"	15 ³ / ₄ "	27 ³ / ₃₂ "	CRMP2HFF	•	•	•	•	•
-----	----------------------------------	-----------------------------------	-----------------	---	---	---	---	---

Pedestal Cushion Top

18 ⁷ / ₈ " or 22"	15 ³ / ₄ "	1 ¹ / ₂ "	CRC					
--	----------------------------------	---------------------------------	------------	--	--	--	--	--

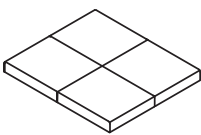
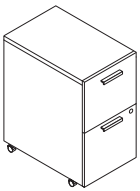
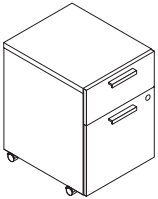

Tip: Two-High mobile pedestal will not fit under desk when cushion is selected.

Currency One-High, 1.5-High, and Two-High Lateral Files

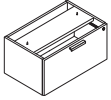

Standard Includes		Required to Specify
<ul style="list-style-type: none"> ▶ See <i>Currency Specification Guide</i> for product details. 	<ul style="list-style-type: none"> One-High, 1.5-High, and Two-High lateral files: <ul style="list-style-type: none"> – Low-Pressure Laminate case with matching or contrasting Low-Pressure Laminate headset – Low-Pressure Laminate case with High-Pressure Laminate headset, if selected – High-Pressure Laminate case with matching or contrasting High-Pressure Laminate headset, if selected Finished back 1 1/8" thick top: Low-Pressure Laminate, if selected Bore and dowel drawer construction: black One fastened plastic filing system per file drawer: black only Full extension, heavy-duty ball bearing drawer suspensions Two counterweights Attachment hardware 1 1/4" adjustable leveling glides Shipped fully assembled Edge finish to match top, if selected 	<ol style="list-style-type: none"> Style number Size type (see below under Required Selections) Depth (see below under Required Selections) Width (see below under Required Selections) Application (see below under Required Selections) Low-Pressure Laminate or High-Pressure Laminate color number for case Low-Pressure Laminate or High-Pressure Laminate color number for headset Low-Pressure Laminate or High-Pressure Laminate color number for top, if selected Plastic color number for all edges on laminate top Pulls (see below under Required Selections) Options, if selected (see below) <ul style="list-style-type: none"> ▶ See <i>Surface Materials</i>, page 480. <i>Tip: Remember to specify lock cylinder and key.</i> ▶ <i>Lock Cylinders</i>, page 441

Required Selections		Required to Specify
Size Type	<ul style="list-style-type: none"> Modular 	Specify with <i>modular</i> .
Depth	<ul style="list-style-type: none"> 18 7/8"D 22 3/4"D 24"D 	Specify 18 7/8" depth. Specify 22 3/4" depth. Specify 24" depth.
Width	<ul style="list-style-type: none"> 30"W 36"W 	Specify 30" width. Specify 36" width.
Application	<ul style="list-style-type: none"> Full Recessed 	Specify with <i>full</i> . Specify with <i>recessed</i> .

Tip: Recessed back option automatically removes top. Specify square edge top with 1/2" cord drop and power access door separately.

Tip: For Answer beam applications where low storage supports overheads or organizers with mid-storage supports, omit the 1"H top on the lower storage and specify a square edge top.

Pull Shape

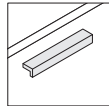

Ledge

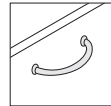

Handle

Options		Required to Specify
Surface Materials	Case <ul style="list-style-type: none"> Low-Pressure Laminate (LPL) price group 1 High-Pressure Laminate (HPL) price group 1 High-Pressure Laminate (HPL) price group 3 	Specify laminate color number. Specify laminate color number. Specify laminate color number.
	Headset <ul style="list-style-type: none"> Low-Pressure Laminate (LPL) price group 1 High-Pressure Laminate (HPL) price group 1 High-Pressure Laminate (HPL) price group 3 	Specify laminate color number. Specify laminate color number. Specify laminate color number.
	Top <ul style="list-style-type: none"> Low-Pressure Laminate (LPL) price group 1 High-Pressure Laminate (HPL) price group 1 High-Pressure Laminate (HPL) price group 3 	Specify laminate color number. Specify laminate color number. Specify laminate color number.
Top Option	<ul style="list-style-type: none"> No top With top 	Specify with <i>no top</i> . Specify with <i>top</i> .
Pulls	<ul style="list-style-type: none"> Handle Ledge 	Specify with <i>handle pull</i> . Specify with <i>ledge pull</i> .

▶ Options, continued on next page

► Options, continued from previous page

Options		Required to Specify
Counterweight	<ul style="list-style-type: none"> No counterweight With counterweight 	Specify with <i>no counterweight</i> . Specify with <i>counterweight</i> .
Keys	<ul style="list-style-type: none"> Key plug Master key plug 	Specify with <i>key plug</i> . Specify with <i>master key plug</i> .

Specification Information					
Modular Depth	Modular Width	Style Number	Low-Pressure Laminate Case with Headset	Low-Pressure Laminate Case with High-Pressure Laminate Headset	High-Pressure Laminate Case with Headset

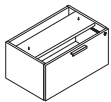

One-High Laterals

One File Drawer					
Modular Depth	Modular Width	Style Number	Low-Pressure Laminate Case with Headset	Low-Pressure Laminate Case with High-Pressure Laminate Headset	High-Pressure Laminate Case with Headset
18 ⁷ / ₈ "	30"	CRL1H	•	•	•
18 ⁷ / ₈ "	36"	CRL1H	•	•	•
24"	30"	CRL1H	•	•	•
24"	36"	CRL1H	•	•	•

1.5-High Laterals

One Open, One File Drawer					
Modular Depth	Modular Width	Style Number	Low-Pressure Laminate Case with Headset	Low-Pressure Laminate Case with High-Pressure Laminate Headset	High-Pressure Laminate Case with Headset
18 ⁷ / ₈ "	30"	CRL15HOF	•	•	•
18 ⁷ / ₈ "	36"	CRL15HOF	•	•	•
24"	30"	CRL15HOF	•	•	•
24"	36"	CRL15HOF	•	•	•

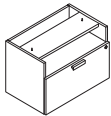

One Box, One File Drawer					
Modular Depth	Modular Width	Style Number	Low-Pressure Laminate Case with Headset	Low-Pressure Laminate Case with High-Pressure Laminate Headset	High-Pressure Laminate Case with Headset
18 ⁷ / ₈ "	30"	CRL15HBF	•	•	•
18 ⁷ / ₈ "	36"	CRL15HBF	•	•	•
24"	30"	CRL15HBF	•	•	•
24"	36"	CRL15HBF	•	•	•

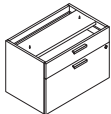

Two-High Laterals

Two File Drawers					
Modular Depth	Modular Width	Style Number	Low-Pressure Laminate Case with Headset	Low-Pressure Laminate Case with High-Pressure Laminate Headset	High-Pressure Laminate Case with Headset
18 ⁷ / ₈ "	30"	CRL2H	•	•	•
18 ⁷ / ₈ "	36"	CRL2H	•	•	•
22 ³ / ₄ "	30"	CRL2H	•	•	•
22 ³ / ₄ "	36"	CRL2H	•	•	•
24"	30"	CRL2H	•	•	•
24"	36"	CRL2H	•	•	•

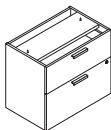

Currency One-High, 1.5-High, and Two-High Lower Storage

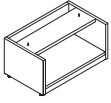

	Standard Includes	Required to Specify
	<ul style="list-style-type: none"> See <i>Currency Specification Guide</i> for product details. Lower storage, if One-High lower storage, 1.5-High open lower storage, or Two-High open lower storage is selected: <ul style="list-style-type: none"> Low-Pressure Laminate case High-Pressure Laminate case, if selected Lower storage, if 1.5-High or Two-High lower storage with doors is selected: <ul style="list-style-type: none"> Low-Pressure Laminate case with matching or contrasting Low-Pressure Laminate headset Low-Pressure Laminate case with High-Pressure Laminate headset, if selected High-Pressure Laminate case with matching or contrasting High-Pressure Laminate headset, if selected Finished back 1 1/8" thick top: Low-Pressure Laminate, if selected Pulls on 1.5-High and Two-High lower storage with doors, if selected Lock on 1.5-High and Two-High lower storage with doors, if selected: lock plug Attachment hardware 1 1/4" adjustable leveling glides One adjustable shelf (1.5-High and Two-High) Shipped fully assembled Edge finish to match top, if selected 	<ol style="list-style-type: none"> Style number Size type (see below under Required Selections) Depth (see below under Required Selections) Width (see below under Required Selections) Application (see below under Required Selections) Low-Pressure Laminate or High-Pressure Laminate color number for case Low-Pressure Laminate or High-Pressure Laminate color number for headset Low-Pressure Laminate or High-Pressure Laminate color number for top, if selected Plastic color number for all edges on laminate top Pulls (see below under Required Selections) Options, if selected (see below) <ul style="list-style-type: none"> See <i>Surface Materials</i>, page 480. <ul style="list-style-type: none"> Tip: Remember to specify lock cylinder and key. Lock Cylinders, page 441

	Required Selections	Required to Specify
Size Type	<ul style="list-style-type: none"> Modular 	Specify with modular.
Depth	<ul style="list-style-type: none"> 18 7/8"D 22 3/4"D 24"D 	Specify 18 7/8" depth. Specify 22 3/4" depth. Specify 24" depth.
Width	<ul style="list-style-type: none"> 30"W 36"W 42"W 	Specify 30" width. Specify 36" width. Specify 42" width.
Application	<ul style="list-style-type: none"> Full Recessed 	Specify with full. Specify with recessed.

Pull Shape

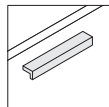

Ledge

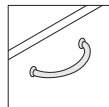

Handle

Tip: Recessed back option automatically removes top. Specify square edge top with 1/2" cord drop and power access door separately.

Tip: For Answer beam applications where low storage supports overheads or organizers with mid-storage supports, omit the 1"H top on the lower storage and specify a square edge top.

	Options	Required to Specify
Surface Materials	<p>Case</p> <ul style="list-style-type: none"> Low-Pressure Laminate (LPL) price group 1 High-Pressure Laminate (HPL) price group 1 High-Pressure Laminate (HPL) price group 3 <p>Headset</p> <ul style="list-style-type: none"> Low-Pressure Laminate (LPL) price group 1 High-Pressure Laminate (HPL) price group 1 High-Pressure Laminate (HPL) price group 3 <p>Top</p> <ul style="list-style-type: none"> Low-Pressure Laminate (LPL) price group 1 High-Pressure Laminate (HPL) price group 1 High-Pressure Laminate (HPL) price group 3 	Specify laminate color number. Specify laminate color number. Specify laminate color number. Specify laminate color number. Specify laminate color number. Specify laminate color number. Specify laminate color number. Specify laminate color number. Specify laminate color number.

► Options, continued on next page

► Options, continued from previous page

Options		Required to Specify
Top Option	<ul style="list-style-type: none"> No top With top 	Specify <i>with no top</i> . Specify <i>with top</i> .
Pulls	<ul style="list-style-type: none"> Handle Ledge 	Specify <i>with handle pull</i> . Specify <i>with ledge pull</i> .
Keys	<ul style="list-style-type: none"> Key plug Master key plug 	Specify <i>with key plug</i> . Specify <i>with master key plug</i> .

Specification Information

Modular Depth	Style Number	Modular Width		
		30"	36"	42"

One-High Lower Storage

Open, Low-Pressure Laminate Case

18 ⁷ / ₈ "	CRLS1H	•	•	•
24"	CRLS1H	•	•	•

Open, High-Pressure Laminate Case

18 ⁷ / ₈ "	CRLS1H	•	•	•
24"	CRLS1H	•	•	•

1.5-High Lower Storage

Open, Low-Pressure Laminate Case

18 ⁷ / ₈ "	CRLS15HO	•	•	•
24"	CRLS15HO	•	•	•

Open, High-Pressure Laminate Case

18 ⁷ / ₈ "	CRLS15HO	•	•	•
24"	CRLS15HO	•	•	•

1.5-High Lower Storage

Cabinet, Low-Pressure Laminate Case with Headset

18 ⁷ / ₈ "	CRLS15HD	•	•	•
24"	CRLS15HD	•	•	•

Cabinet, Low-Pressure Laminate Case with High-Pressure Laminate Headset

18 ⁷ / ₈ "	CRLS15HD	•	•	•
24"	CRLS15HD	•	•	•

Cabinet, High-Pressure Laminate Case with Headset

18 ⁷ / ₈ "	CRLS15HD	•	•	•
24"	CRLS15HD	•	•	•

► Specification Information, continued on next page

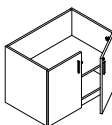
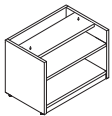
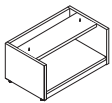

► Specification Information, continued from previous page

Specification Information				
Modular Depth	Style Number	Modular Width		
		30"	36"	42"

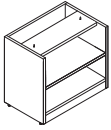

Two-High Lower Storage

Open, Low-Pressure Laminate Case

18 ⁷ / ₈ "	CRLS2HO	•	•	•
22 ³ / ₄ "	CRLS2HO	•	•	•
24"	CRLS2HO	•	•	•

Open, High-Pressure Laminate Case

18 ⁷ / ₈ "	CRLS2HO	•	•	•
22 ³ / ₄ "	CRLS2HO	•	•	•
24"	CRLS2HO	•	•	•

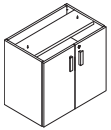

Two-High Lower Storage

Cabinet, Low-Pressure Laminate Case with Headset

18 ⁷ / ₈ "	CRLS2HD	•	•	•
22 ³ / ₄ "	CRLS2HD	•	•	•
24"	CRLS2HD	•	•	•

Cabinet, Low-Pressure Laminate Case with High-Pressure Laminate Headset

18 ⁷ / ₈ "	CRLS2HD	•	•	•
22 ³ / ₄ "	CRLS2HD	•	•	•
24"	CRLS2HD	•	•	•

Cabinet, High-Pressure Laminate Case with Headset

18 ⁷ / ₈ "	CRLS2HD	•	•	•
22 ³ / ₄ "	CRLS2HD	•	•	•
24"	CRLS2HD	•	•	•

Currency Storage Filler Panels

Tip: Storage filler panels are used for units of same height with finished backs only; not for use with recessed or open back units.

Standard Includes		Required to Specify
▶ See <i>Currency Specification Guide</i> for product details.	<ul style="list-style-type: none"> Low-Pressure Laminate price group 1 High-Pressure Laminate price group 1, if selected 	1 Style number 2 Low-Pressure Laminate color number for filler panel 3 Options, if selected (see below) ▶ See <i>Surface Materials</i> , page 480.

Options		Required to Specify
Surface Materials	Panel <ul style="list-style-type: none"> Low-Pressure Laminate (LPL) price group 1 High-Pressure Laminate (HPL) price group 1 High-Pressure Laminate (HPL) price group 3 	Specify laminate color number. Specify laminate color number. Specify laminate color number.
Storage Height	<ul style="list-style-type: none"> One-High 1.5-High Two-High 	Specify with <i>One-High storage height</i> . Specify with <i>1.5-High storage height</i> . Specify with <i>Two-High storage height</i> .

Specification Information

Dimensions			Style	LPL	HPL
D	W	H	Number		

One-High Filler Panel

1"	5 $\frac{1}{8}$ "	15 $\frac{3}{8}$ "	CRFP	•	•
:	:	:	:	:	:

1.5-High Filler Panel

1"	5 $\frac{1}{8}$ "	21 $\frac{3}{8}$ "	CRFP	•	•
:	:	:	:	:	:

Two-High Filler Panel

1"	5 $\frac{1}{8}$ "	27 $\frac{3}{8}$ "	CRFP	•	•
:	:	:	:	:	:



Currency One-High and 1.5-High Open Storage

For Ology, Migration SE, or Slim Leg HAD Application

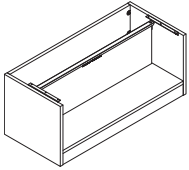

Tip: The actual thickness between Low-Pressure Laminate (LPL) and High-Pressure Laminate (HPL) worksurfaces is slightly different. It is recommended that only worksurfaces of the same type are specified in a given application. In addition, there may be sheen or texture differences when using LPL and HPL in adjacent applications.

Standard Includes		Required to Specify
<ul style="list-style-type: none"> ▶ See <i>Currency Specification Guide</i> for product details. 	<ul style="list-style-type: none"> Case, One-High and 1.5-High: <ul style="list-style-type: none"> – Low-Pressure Laminate price group 1 – High-Pressure Laminate price group 1, if selected Removable interior cover Shelf, if 1.5-High unit is selected Grommet Wire manager 1 ¼" adjustable leveling glides Shipped fully assembled 	<ol style="list-style-type: none"> Style number Size type (see below under Required Selections) Depth (see below under Required Selections) Width (see below under Required Selections) Desk type (see below under Required Selections) Low-Pressure Laminate color number for case Options, if selected (see below) <p>▶ See <i>Surface Materials</i>, page 480.</p>

Required Selections		Required to Specify
Size Types	<ul style="list-style-type: none"> Modular 	Specify <i>with modular</i> .
Depth	<ul style="list-style-type: none"> 18⁷/₈"D 24"D 	Specify 18 ⁷ / ₈ " depth. Specify 24" depth.
Width	<ul style="list-style-type: none"> 30"W 36"W 42"W 48"W 60"W 72"W 	Specify 30" width. Specify 36" width. Specify 42" width. Specify 48" width. Specify 60" width. Specify 72" width.
Desk Type	<ul style="list-style-type: none"> Migration SE Ology Slim Leg HAD 	Specify <i>with Migration SE</i> . Specify <i>with Ology</i> . Specify <i>Slim Leg HAD</i> .

Options		Required to Specify
Surface Materials	<p>Case</p> <ul style="list-style-type: none"> Low-Pressure Laminate (LPL) price group 1 High-Pressure Laminate (HPL) price group 1 High-Pressure Laminate (HPL) price group 3 	Specify laminate color number. Specify laminate color number. Specify laminate color number.
Back Panel	<ul style="list-style-type: none"> No back panel With a back panel 30"W–42"W With a back panel 42¹/₁₆"W–72"W 	Specify <i>without back panel</i> . Specify <i>with back panel</i> . Specify <i>with back panel</i> .

Specification Information

Dimensions		Style Number	Modular Width					
Modular Depth	Modular Height		30"	36"	42"	48"	60"	72"

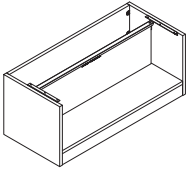

One-High Open Storage for Ology, Migration SE, or Slim Leg HAD Application

Low-Pressure Laminate

18 ⁷ / ₈ "	15 ³ / ₈ "	CRHAD1H	•	•	•	•	•	•
24"	15 ³ / ₈ "	CRHAD1H	•	•	•	•	•	•

High-Pressure Laminate

18 ⁷ / ₈ "	15 ³ / ₈ "	CRHAD1H	•	•	•	•	•	•
24"	15 ³ / ₈ "	CRHAD1H	•	•	•	•	•	•

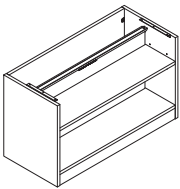

1.5-High Open Storage for Ology, Migration SE, or Slim Leg HAD Application

Low-Pressure Laminate

18 ⁷ / ₈ "	21 ³ / ₈ "	CRHAD15H	•	•	•	•	•	•
24"	21 ³ / ₈ "	CRHAD15H	•	•	•	•	•	•

High-Pressure Laminate

18 ⁷ / ₈ "	21 ³ / ₈ "	CRHAD15H	•	•	•	•	•	•
24"	21 ³ / ₈ "	CRHAD15H	•	•	•	•	•	•

Currency 1.5-High Credenza Storage

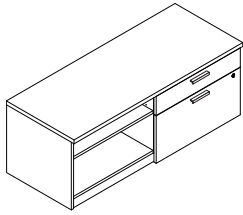

Standard Includes	Required to Specify
<ul style="list-style-type: none"> ▶ See <i>Currency Specification Guide</i> for product details. • 1.5-High credenza, if open/open is selected: <ul style="list-style-type: none"> – Low-Pressure Laminate case, price group 1 – High-Pressure Laminate case, price group 1, if selected • 1.5-High credenza, if open/lateral file or lateral file/lateral file is selected: <ul style="list-style-type: none"> – Low-Pressure Laminate case, price group 1 – Low-Pressure Laminate case with High-Pressure Laminate headset, if selected – High-Pressure Laminate case with matching or contrasting High-Pressure Laminate headset, if selected • Finished back • 1 1/8" thick top: Low-Pressure Laminate, if selected • Adjustable shelf on open/open configuration and open/lateral file configuration • Lock on open/lateral file or lateral file/lateral file configuration, if selected, plug • Four counterweights on units with drawers • 1 1/4" leveling glides • Shipped fully assembled 	<ol style="list-style-type: none"> 1 Style number 2 Size type (see below under Required Selections) 3 Depth (see below under Required Selections) 4 Width (see below under Required Selections) 5 Application (see below under Required Selections) 6 Storage configuration (see below under Required Selections) 7 Low-Pressure Laminate or High-Pressure Laminate color number for case 8 Low-Pressure Laminate or High-Pressure Laminate color number for headset 9 Low-Pressure Laminate or High-Pressure Laminate color number for top, if selected 10 Plastic color number for all edges on laminate top 11 Pulls (see below under Required Selections) 12 Options, if selected (see below) <p>▶ See <i>Surface Materials</i>, page 480.</p>

	Required Selections	Required to Specify
Size Type	• Modular	Specify with modular.
Depth	• 18 7/8"D • 24"D	Specify 18 7/8" depth. Specify 24" depth.
Width	• 42"W • 48"W • 60"W • 66"W • 72"W	Specify 42" width. Specify 48" width. Specify 60" width. Specify 66" width. Specify 72" width.
Storage Configuration	• 30" left lateral/36" right lateral • 36" left lateral/30" right lateral	Specify with 30" left lateral/36" right lateral configuration. Specify with 36" left lateral/30" right lateral configuration.
Application	• Full • Recessed	Specify with full application. Specify with recessed application.

Pull Shape

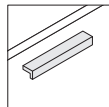

Ledge

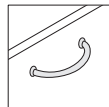

Handle

Tip: For a 42"W open/open configuration, refer to 42" open low storage.

Tip: Open/open configuration does not include a headset.

Options		Required to Specify
Surface Materials	Case	
	<ul style="list-style-type: none"> Low-Pressure Laminate (LPL) price group 1 High-Pressure Laminate (HPL) price group 1 High-Pressure Laminate (HPL) price group 3 	Specify laminate color number. Specify laminate color number. Specify laminate color number.
	Headset	
	<ul style="list-style-type: none"> Low-Pressure Laminate (LPL) price group 1 High-Pressure Laminate (HPL) price group 1 High-Pressure Laminate (HPL) price group 3 	Specify laminate color number. Specify laminate color number. Specify laminate color number.
	Top	
	<ul style="list-style-type: none"> Low-Pressure Laminate (LPL) price group 1 High-Pressure Laminate (HPL) price group 1 High-Pressure Laminate (HPL) price group 3 	Specify laminate color number. Specify laminate color number. Specify laminate color number.
Top	<ul style="list-style-type: none"> No top With top 	Specify <i>without top</i> . Specify <i>with top</i> .
Pulls	<ul style="list-style-type: none"> Handle Ledge 	Specify <i>with handle pull</i> . Specify <i>with ledge pull</i> .
Keys	<ul style="list-style-type: none"> Key plug Master key plug 	Specify <i>with key plug</i> . Specify <i>with master key plug</i> .

Tip: Recessed back option automatically removes top. Specify square edge top with 1/2" cord drop and power access door separately.

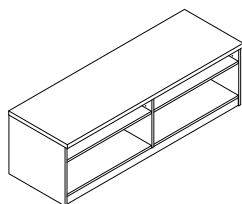

Tip: Center panel splits width evenly on modular sizes.

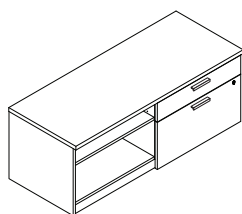

Specification Information

Modular Depth	Style Number	Modular Width				
		42"	48"	60"	66"	72"

Open/Open Configuration Low-Pressure Laminate Case

18 7/8"	CRCD15HFS00	•	•	•	•	•
24"	CRCD15HFS00	•	•	•	•	•

Open/Open Configuration High-Pressure Laminate Case

18 7/8"	CRCD15HFS00	•	•	•	•	•
24"	CRCD15HFS00	•	•	•	•	•

Open/Lateral File Configuration, Low-Pressure Laminate Case with Headset

18 7/8"	CRCD15HFSLFR	•	•	•	•	•
24"	CRCD15HFSLFR	•	•	•	•	•

Open/Lateral File Configuration, Low-Pressure Laminate Case with High-Pressure Laminate Headset

18 7/8"	CRCD15HFSLFR	•	•	•	•	•
24"	CRCD15HFSLFR	•	•	•	•	•

Open/Lateral File Configuration, High-Pressure Laminate Case with Headset

18 7/8"	CRCD15HFSLFR	•	•	•	•	•
24"	CRCD15HFSLFR	•	•	•	•	•

► Specification Information, continued on next page

► Specification Information, continued from previous page

Specification Information						
Modular Depth	Style Number	Modular Width				
		42"	48"	60"	66"	72"
Lateral File/Open Configuration, Low-Pressure Laminate Case with Headset						
18 ⁷ / ₈ "	CRCD15HFSLFL	•	•	•	•	•
24"	CRCD15HFSLFL	•	•	•	•	•
Lateral File/Open Configuration, Low-Pressure Laminate Case with High-Pressure Laminate Headset						
18 ⁷ / ₈ "	CRCD15HFSLFL	•	•	•	•	•
24"	CRCD15HFSLFL	•	•	•	•	•
Lateral File/Open Configuration, High-Pressure Laminate Case with Headset						
18 ⁷ / ₈ "	CRCD15HFSLFL	•	•	•	•	•
24"	CRCD15HFSLFL	•	•	•	•	•
Lateral File/Lateral File Configuration, Low-Pressure Laminate Case with Headset						
18 ⁷ / ₈ "	CRCD15HFSLL	N.A.	N.A.	•	•	•
24"	CRCD15HFSLL	N.A.	N.A.	•	•	•
Lateral File/Lateral File Configuration, Low-Pressure Laminate Case with High-Pressure Laminate Headset						
18 ⁷ / ₈ "	CRCD15HFSLL	N.A.	N.A.	•	•	•
24"	CRCD15HFSLL	N.A.	N.A.	•	•	•
Lateral File/Lateral File Configuration, High-Pressure Laminate Case with Headset						
18 ⁷ / ₈ "	CRCD15HFSLL	N.A.	N.A.	•	•	•
24"	CRCD15HFSLL	N.A.	N.A.	•	•	•
:	:	:	:	:	:	:

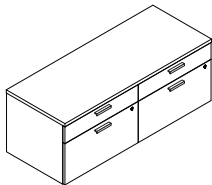
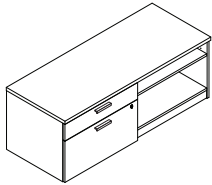

Currency Two-High Credenza Storage

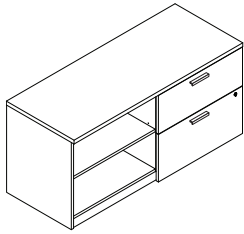

► See *Currency Specification Guide* for product details.

Standard Includes

- Two-High credenza, if open/open is selected:
 - Low-Pressure Laminate case, price group 1
 - High-Pressure Laminate case, price group 1, if selected
- Two-High credenza, if open/lateral file or lateral file/lateral file is selected:
 - Low-Pressure Laminate case, price group 1
 - Low-Pressure Laminate case with High-Pressure Laminate headset, if selected
 - High-Pressure Laminate case with matching or contrasting High-Pressure Laminate headset, if selected
- 1 1/8" thick top:
 - Low-Pressure Laminate price group 1
 - High-Pressure Laminate price group 1, if selected
- Finished back
- 1 1/8" thick top: Low-Pressure Laminate, if selected
- Adjustable shelf on open/open, open/lateral file, lateral file/cabinet, and cabinet/cabinet configurations
- Lock on open/lateral file, lateral file/lateral file, cabinet/lateral file, or cabinet/cabinet, if selected, plug
- Four counterweights on units with drawers
- 1 1/4" leveling glides
- Shipped fully assembled

Required to Specify

- 1 Style number
- 2 Size type (see below under Required Selections)
- 3 Depth (see below under Required Selections)
- 4 Width (see below under Required Selections)
- 5 Application (see below under Required Selections)
- 6 Storage configuration (see below under Required Selections)
- 7 Low-Pressure Laminate or High-Pressure Laminate color number for case
- 8 Low-Pressure Laminate or High-Pressure Laminate color number for headset
- 9 Low-Pressure Laminate or High-Pressure Laminate color number for top, if selected
- 10 Plastic color number for all edges on laminate top
- 11 Pulls (see below under Required Selections)
- 12 Options, if selected (see below)
 - See *Surface Materials*, page 480.

Required Selections		Required to Specify
Size Type	• Modular	Specify with <i>modular</i> .
Depth	• 18 7/8"D • 24"D	Specify 18 7/8" depth. Specify 24" depth.
Width	• 42"W • 48"W • 60"W • 66"W • 72"W	Specify 42" width. Specify 48" width. Specify 60" width. Specify 66" width. Specify 72" width.
Storage Configuration	• 30" left lateral/36" right lateral • 36" left lateral/30" right lateral	Specify with <i>30" left lateral/36" right lateral configuration</i> . Specify with <i>36" left lateral/30" right lateral configuration</i> .
Application	• Full • Recessed	Specify with <i>full application</i> . Specify with <i>recessed application</i> .

Pull Shape

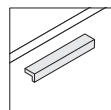

Ledge

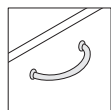

Handle

Tip: Open/open configuration does not include a headset.

Tip: Recessed back option automatically removes top. Specify square edge top with 1/2" cord drop and power access door separately.

Options		Required to Specify
Surface Materials	Case	Specify laminate color number. Specify laminate color number. Specify laminate color number.
	• Low-Pressure Laminate (LPL) price group 1	
	• High-Pressure Laminate (HPL) price group 1 • High-Pressure Laminate (HPL) price group 3	
	Headset	Specify laminate color number. Specify laminate color number. Specify laminate color number.
	• Low-Pressure Laminate (LPL) price group 1	
	• High-Pressure Laminate (HPL) price group 1 • High-Pressure Laminate (HPL) price group 3	
	Top	Specify laminate color number. Specify laminate color number. Specify laminate color number.
	• Low-Pressure Laminate (LPL) price group 1	
	• High-Pressure Laminate (HPL) price group 1 • High-Pressure Laminate (HPL) price group 3	
Top Option	• No top • With top	Specify <i>without top</i> . Specify <i>with top</i> .
Pulls	• Handle • Ledge	Specify <i>with handle pull</i> . Specify <i>with ledge pull</i> .
Keys	• Key plug • Master key plug	Specify <i>with key plug</i> . Specify <i>with master key plug</i> .

Specification Information					
Modular Depth	Style Number	Modular Width			
		42"	48"	60"	66"

Open/Open Configuration Low-Pressure Laminate Case					
18 ⁷ / ₈ "	CRCD2HFSOO	•	•	•	•
24"	CRCD2HFSOO	•	•	•	•

Open/Open Configuration High-Pressure Laminate Case					
18 ⁷ / ₈ "	CRCD2HFSOO	•	•	•	•
24"	CRCD2HFSOO	•	•	•	•

Open/Lateral File Configuration, Low-Pressure Laminate Case with Headset					
18 ⁷ / ₈ "	CRCD2HFSLFR	•	•	•	•
24"	CRCD2HFSLFR	•	•	•	•

Open/Lateral File Configuration, Low-Pressure Laminate Case with High-Pressure Laminate Headset					
18 ⁷ / ₈ "	CRCD2HFSLFR	•	•	•	•
24"	CRCD2HFSLFR	•	•	•	•

Open/Lateral File Configuration, High-Pressure Laminate Case with Headset					
18 ⁷ / ₈ "	CRCD2HFSLFR	•	•	•	•
24"	CRCD2HFSLFR	•	•	•	•

► Specification Information, continued on next page

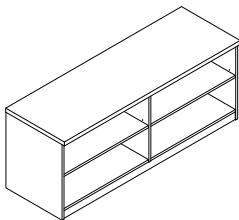

Tip: Center panel splits width evenly on modular sizes.

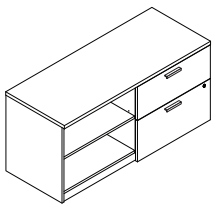

Tip: Center panel splits width evenly on modular sizes.

► Specification Information, continued from previous page

Specification Information						
Modular Depth	Style Number	Modular Width				
		42"	48"	60"	66"	72"
Lateral File/Open Configuration, Low-Pressure Laminate Case with Headset						
18 ⁷ / ₈ "	CRCD2HFSLFL	•	•	•	•	•
24"	CRCD2HFSLFL	•	•	•	•	•
Lateral File/Open Configuration, Low-Pressure Laminate Case with High-Pressure Laminate Headset						
18 ⁷ / ₈ "	CRCD2HFSLFL	•	•	•	•	•
24"	CRCD2HFSLFL	•	•	•	•	•
Lateral File/Open Configuration, High-Pressure Laminate Case with Headset						
18 ⁷ / ₈ "	CRCD2HFSLFL	•	•	•	•	•
24"	CRCD2HFSLFL	•	•	•	•	•
Lateral File/Lateral File Configuration, Low-Pressure Laminate Case with Headset						
18 ⁷ / ₈ "	CRCD2HFSLL	N.A.	N.A.	•	•	•
24"	CRCD2HFSLL	N.A.	N.A.	•	•	•
Lateral File/Lateral File Configuration, Low-Pressure Laminate Case with High-Pressure Laminate Headset						
18 ⁷ / ₈ "	CRCD2HFSLL	N.A.	N.A.	•	•	•
24"	CRCD2HFSLL	N.A.	N.A.	•	•	•
Lateral File/Lateral File Configuration, High-Pressure Laminate Case with Headset						
18 ⁷ / ₈ "	CRCD2HFSLL	N.A.	N.A.	•	•	•
24"	CRCD2HFSLL	N.A.	N.A.	•	•	•

► Specification Information, continued on next page

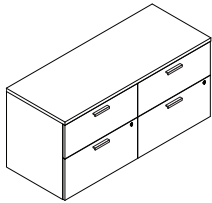
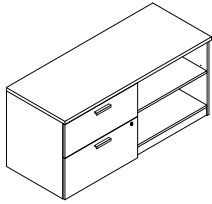

► Specification Information, continued from previous page

Specification Information

Modular Depth	Style Number	Modular Width				
		42"	48"	60"	66"	72"

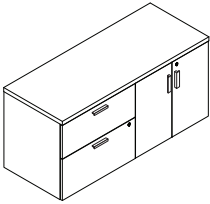

Lateral File/Cabinet Configuration, Low-Pressure Laminate Case with Headset						
18 ⁷ / ₈ "	CRCD2HFSLCLFL	N.A.	N.A.	•	•	•
24"	CRCD2HFSLCLFL	N.A.	N.A.	•	•	•

Lateral File/Cabinet Configuration, Low-Pressure Laminate Case with High-Pressure Laminate Headset						
18 ⁷ / ₈ "	CRCD2HFSLCLFL	N.A.	N.A.	•	•	•
24"	CRCD2HFSLCLFL	N.A.	N.A.	•	•	•

Lateral File/Cabinet Configuration, High-Pressure Laminate Case with Headset						
18 ⁷ / ₈ "	CRCD2HFSLCLFL	N.A.	N.A.	•	•	•
24"	CRCD2HFSLCLFL	N.A.	N.A.	•	•	•

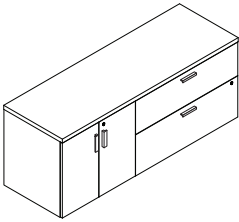

Cabinet/Lateral File Configuration, Low-Pressure Laminate Case with Headset						
18 ⁷ / ₈ "	CRCD2HFSLCLFR	N.A.	N.A.	•	•	•
24"	CRCD2HFSLCLFR	N.A.	N.A.	•	•	•

Cabinet/Lateral File Configuration, Low-Pressure Laminate Case with High-Pressure Laminate Headset						
18 ⁷ / ₈ "	CRCD2HFSLCLFR	N.A.	N.A.	•	•	•
24"	CRCD2HFSLCLFR	N.A.	N.A.	•	•	•

Cabinet/Lateral File Configuration, High-Pressure Laminate Case with Headset						
18 ⁷ / ₈ "	CRCD2HFSLCLFR	N.A.	N.A.	•	•	•
24"	CRCD2HFSLCLFR	N.A.	N.A.	•	•	•

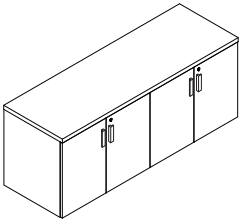

Cabinet/Cabinet Configuration, Low-Pressure Laminate Case with Headset						
18 ⁷ / ₈ "	CRCD2HFSCC	N.A.	N.A.	•	•	•
24"	CRCD2HFSCC	N.A.	N.A.	•	•	•

Cabinet/Cabinet Configuration, Low-Pressure Laminate Case with High-Pressure Laminate Headset						
18 ⁷ / ₈ "	CRCD2HFSCC	N.A.	N.A.	•	•	•
24"	CRCD2HFSCC	N.A.	N.A.	•	•	•

Tip: Center panel splits width evenly on modular sizes.

Cabinet/Cabinet Configuration, High-Pressure Laminate Case with Headset						
18 ⁷ / ₈ "	CRCD2HFSCC	N.A.	N.A.	•	•	•
24"	CRCD2HFSCC	N.A.	N.A.	•	•	•

Currency Two-High Credenza Storage with Kneespace

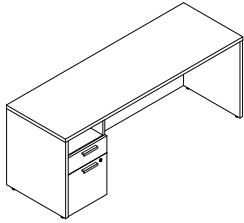

► See *Currency Specification Guide* for product details.

Standard Includes

- Two-High credenza with kneespace:
 - Low-Pressure Laminate case with matching or contrasting Low-Pressure Laminate headset
 - Low-Pressure Laminate case with High-Pressure Laminate headset, if selected
 - High-Pressure Laminate case with matching or contrasting High-Pressure Laminate headset, if selected
- 1 1/8" thick top:
 - Low-Pressure Laminate price group 1
 - High-Pressure Laminate price group 1, if selected
- Finished back
- Modesty panel, full or quarter height
- Bore and dowel drawer construction: black
- One fastened plastic filing system per file drawer: black only
- Full extension, heavy-duty ball bearing drawer suspensions
- One pencil tray is included in units with a box drawer
- Lock plug
- Counterweight
- 1 1/4" leveling glides
- Shipped fully assembled

Required to Specify

- 1 Style number
 - 2 Size type (see below under Required Selections)
 - 3 Depth (see below under Required Selections)
 - 4 Width (see below under Required Selections)
 - 5 Left and right support (see below under Required Selections)
 - 6 Modesty panel (see below under Required Selections)
 - 7 Low-Pressure Laminate or High-Pressure Laminate color number for case
 - 8 Low-Pressure Laminate or High-Pressure Laminate color number for headset
 - 9 Low-Pressure Laminate or High-Pressure Laminate color number for top
 - 10 Plastic color number for all edges on laminate top
 - 11 Pulls (see below under Required Selections)
 - 12 Options, if selected (see below)
- See *Surface Materials*, page 480.

Tip: Reinforcing channels are ordered separately and must be used on credenzas that have 54"W or more of unsupported kneespace (70"W single pedestal units).

Tip: Grain direction of modesty panel runs horizontally. Grain direction of pedestals runs vertically.

Tip: Quarter height modesty panel available on 24"D units only.

	Required Selections	Required to Specify
Size Type	• Modular	Specify with <i>modular</i> .
Depth	• 18 7/8"D • 24"D	Specify 18 7/8" depth. Specify 24" depth.
Width	• 60"W • 66"W • 72"W	Specify 60" width. Specify 66" width. Specify 72" width.
Left Support	• Box/box/file pedestal • File/file pedestal • Open/box/file pedestal	Specify with <i>box/box/file pedestal</i> . Specify with <i>file/file pedestal</i> . Specify with <i>open/box/file pedestal</i> .
Right Support	• Box/box/file pedestal • File/file pedestal • Open/box/file pedestal	Specify with <i>box/box/file pedestal</i> . Specify with <i>file/file pedestal</i> . Specify with <i>open/box/file pedestal</i> .
Modesty Panel	• Full • Quarter height	Specify with <i>full panel</i> . Specify with <i>quarter height panel</i> .

Pull Shape

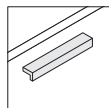

Ledge

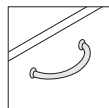

Handle

	Options	Required to Specify
Surface Materials	<p>Case</p> <ul style="list-style-type: none"> • Low-Pressure Laminate (LPL) price group 1 • High-Pressure Laminate (HPL) price group 1 • High-Pressure Laminate (HPL) price group 3 <p>Headset</p> <ul style="list-style-type: none"> • Low-Pressure Laminate (LPL) price group 1 • High-Pressure Laminate (HPL) price group 1 • High-Pressure Laminate (HPL) price group 3 	<p>Specify laminate color number. Specify laminate color number. Specify laminate color number.</p> <p>Specify laminate color number. Specify laminate color number. Specify laminate color number.</p>

► Options, continued on next page

► Options, continued from previous page

Options		Required to Specify
Surface Materials, continued	<ul style="list-style-type: none"> • Low-Pressure Laminate (LPL) price group 1 • High-Pressure Laminate (HPL) price group 1 • High-Pressure Laminate (HPL) price group 3 	Specify laminate color number. Specify laminate color number. Specify laminate color number.
Grommet Location	<ul style="list-style-type: none"> • No grommet • Center • Left • Right • Left and center • Right and center 	Specify <i>without grommet</i> . Specify <i>with center location</i> . Specify <i>with left location</i> . Specify <i>with right location</i> . Specify <i>with left and center location</i> . Specify <i>with right and center location</i> .
Pulls	<ul style="list-style-type: none"> • Handle • Ledge 	Specify <i>with handle pull</i> . Specify <i>with ledge pull</i> .
Keys	<ul style="list-style-type: none"> • Key plug • Master key plug 	Specify <i>with key plug</i> . Specify <i>with master key plug</i> .

Specification Information

Modular Depth	Style Number	Modular Width		
		60"	66"	72"

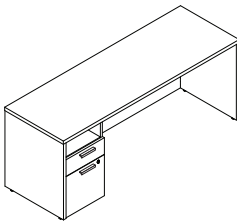

Single Pedestal, Left, Low-Pressure Laminate Case with Low-Pressure Laminate Headset

18 ⁷ / ₈ "	CRCD2HKSSPL	•	•	•
24"	CRCD2HKSSPL	•	•	•

Single Pedestal, Left, Low-Pressure Laminate Case with High-Pressure Laminate Headset

18 ⁷ / ₈ "	CRCD2HKSSPL	•	•	•
24"	CRCD2HKSSPL	•	•	•

Single Pedestal, Left, High-Pressure Laminate Case with High-Pressure Laminate Headset

18 ⁷ / ₈ "	CRCD2HKSSPL	•	•	•
24"	CRCD2HKSSPL	•	•	•

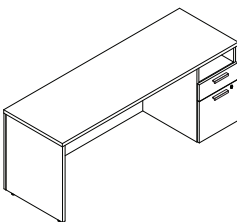

Single Pedestal, Right, Low-Pressure Laminate Case with Low-Pressure Laminate Headset

18 ⁷ / ₈ "	CRCD2HKSSPR	•	•	•
24"	CRCD2HKSSPR	•	•	•

Single Pedestal, Right, Low-Pressure Laminate Case with High-Pressure Laminate Headset

18 ⁷ / ₈ "	CRCD2HKSSPR	•	•	•
24"	CRCD2HKSSPR	•	•	•

Single Pedestal, Right, High-Pressure Laminate Case with High-Pressure Laminate Headset

18 ⁷ / ₈ "	CRCD2HKSSPR	•	•	•
24"	CRCD2HKSSPR	•	•	•

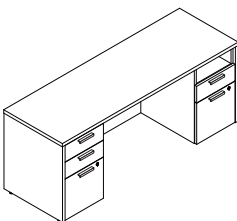

Dual Pedestal, Low-Pressure Laminate Case with Low-Pressure Laminate Headset

18 ⁷ / ₈ "	CRCD2HKSDP	•	•	•
24"	CRCD2HKSDP	•	•	•

Dual Pedestal, Low-Pressure Laminate Case with High-Pressure Laminate Headset

18 ⁷ / ₈ "	CRCD2HKSDP	•	•	•
24"	CRCD2HKSDP	•	•	•

Dual Pedestal, High-Pressure Laminate Case with High-Pressure Laminate Headset

18 ⁷ / ₈ "	CRCD2HKSDP	•	•	•
24"	CRCD2HKSDP	•	•	•

Currency Bookcases

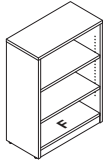

Standard Includes		Required to Specify
<ul style="list-style-type: none"> ▶ See <i>Currency Specification Guide</i> for product details. 	<ul style="list-style-type: none"> Bookcase: <ul style="list-style-type: none"> – Low-Pressure Laminate price group 1 – High-Pressure Laminate price group 1, if selected 1 1/8" thick top: laminate to match case Adjustable shelf: laminate to match case Brackets for shelves: brushed nickel only 1 1/4" leveling glides Shipped fully assembled 	<ol style="list-style-type: none"> Style number Size type (see below under Required Selections) Depth (see below under Required Selections) Width (see below under Required Selections) Height (see below under Required Selections) Low-Pressure Laminate or High-Pressure Laminate color number for case Plastic color number for all edges on laminate case Options, if selected (see below) <ul style="list-style-type: none"> ▶ See <i>Surface Materials</i>, page 480.

Required Selections		Required to Specify
Size Type	<ul style="list-style-type: none"> Modular 	Specify <i>with modular</i> .
Depth	<ul style="list-style-type: none"> 15"D 24"D 	Specify 15" depth. Specify 24" depth.
Width	<ul style="list-style-type: none"> 24"W 30"W 36"W 	Specify 24" width. Specify 30" width. Specify 36" width.
Height	<ul style="list-style-type: none"> 41 3/4"H 47 15/16"H 54 1/8"H 66 1/2"H 72"H 78"H 84"H 	Specify 41 3/4" height. Specify 47 15/16" height. Specify 54 1/8" height. Specify 66 1/2" height. Specify 72" height. Specify 78" height. Specify 84" height.

▶ See *Currency Specification Guide* for shelf count by application height.

Tip: Fixed shelf at worksurface height for bookcases 66 1/2" and taller.

Options		Required to Specify
Surface Materials	Case <ul style="list-style-type: none"> Low-Pressure Laminate (LPL) price group 1 High-Pressure Laminate (HPL) price group 1 High-Pressure Laminate (HPL) price group 3 	Specify laminate color number. Specify laminate color number. Specify laminate color number.

Specification Information

• Dimensions		• Style Number	• Modular Depth	
Modular Height	Modular Width		15"	24"

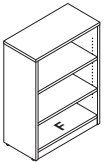

Bookcases with Adjustable Shelves

Low-Pressure Laminate Case

41 ³ / ₄ "	24"	CRBK	•	•
47 ¹⁵ / ₁₆ "	24"	CRBK	•	•
54 ¹ / ₈ "	24"	CRBK	•	•
66 ¹ / ₂ "	24"	CRBK	•	•
72"	24"	CRBK	•	•
78"	24"	CRBK	•	•
84"	24"	CRBK	•	•
41 ³ / ₄ "	30"	CRBK	•	•
47 ¹⁵ / ₁₆ "	30"	CRBK	•	•
54 ¹ / ₈ "	30"	CRBK	•	•
66 ¹ / ₂ "	30"	CRBK	•	•
72"	30"	CRBK	•	•
78"	30"	CRBK	•	•
84"	30"	CRBK	•	•
41 ³ / ₄ "	36"	CRBK	•	•
47 ¹⁵ / ₁₆ "	36"	CRBK	•	•
54 ¹ / ₈ "	36"	CRBK	•	•
66 ¹ / ₂ "	36"	CRBK	•	•
72"	36"	CRBK	•	•
78"	36"	CRBK	•	•
84"	36"	CRBK	•	•

► **Specification Information, continued on next page**

► Specification Information, continued from previous page

Specification Information				
Dimensions		Style Number	Modular Depth	
Modular Height	Modular Width		15"	24"

Bookcases with Adjustable Shelves, continued

High-Pressure Laminate Case

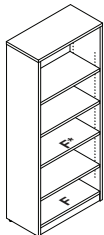
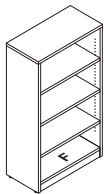
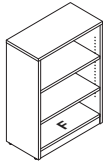

41 ³ / ₄ "	24"	CRBK	•	•
47 ¹⁵ / ₁₆ "	24"	CRBK	•	•
54 ¹ / ₈ "	24"	CRBK	•	•
66 ¹ / ₂ "	24"	CRBK	•	•
72"	24"	CRBK	•	•
78"	24"	CRBK	•	•
84"	24"	CRBK	•	•
41 ³ / ₄ "	30"	CRBK	•	•
47 ¹⁵ / ₁₆ "	30"	CRBK	•	•
54 ¹ / ₈ "	30"	CRBK	•	•
66 ¹ / ₂ "	30"	CRBK	•	•
72"	30"	CRBK	•	•
78"	30"	CRBK	•	•
84"	30"	CRBK	•	•
41 ³ / ₄ "	36"	CRBK	•	•
47 ¹⁵ / ₁₆ "	36"	CRBK	•	•
54 ¹ / ₈ "	36"	CRBK	•	•
66 ¹ / ₂ "	36"	CRBK	•	•
72"	36"	CRBK	•	•
78"	36"	CRBK	•	•
84"	36"	CRBK	•	•
:	:	:	:	:

Currency Stacking Bookcases

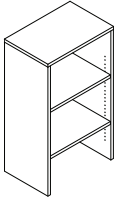

Tip: Stacking bookcases go on top of One-High, 1.5-High, and Two-High Currency low storage. Please specify the application height of the overall height desired with low storage and stacking bookcase combined.

▶ See *Currency Specification Guide* for shelf count by application height.

Tip: Selecting the correct worksurface thickness and top surface materiality type (LPL or HPL) ensures that the stacking bookcase aligns with neighboring tall storage.

Tip: Top surface type refers to the materiality of the storage attaching to the stacking bookcase.

Standard Includes	Required to Specify
<ul style="list-style-type: none"> ▶ See <i>Currency Specification Guide</i> for product details. • Stacking bookcase: <ul style="list-style-type: none"> – Low-Pressure Laminate price group 1 – High-Pressure Laminate price group 1, if selected • 1 1/8" thick top: laminate to match case • Adjustable shelf: laminate to match case • Attachment hardware • Shipped fully assembled 	<ol style="list-style-type: none"> 1 Style number 2 Size type (see below under Required Selections) 3 Depth (see below under Required Selections) 4 Width (see below under Required Selections) 5 Application height (see below under Required Selections) 6 Low-Pressure Laminate or High-Pressure Laminate color number for case 7 Plastic color number for all edges on laminate case 8 Options, if selected (see below) <p>▶ See <i>Surface Materials</i>, page 480.</p>

Required Selections		Required to Specify
Size Type	• Modular	Specify <i>with modular</i> .
Depth	• 15"D • 24"D	Specify 15" depth. Specify 24" depth.
Width	• 24"W • 30"W • 36"W	Specify 24" width. Specify 30" width. Specify 36" width.
Application Height	• 41 3/4"H • 47 15/16"H • 54 1/8"H • 66 1/2"H • 72"H • 78"H • 84"H	Specify 41 3/4" height. Specify 47 15/16" height. Specify 54 1/8" height. Specify 66 1/2" height. Specify 72" height. Specify 78" height. Specify 84" height.

Options		Required to Specify
Surface Materials	Case • Low-Pressure Laminate (LPL) price group 1 • High-Pressure Laminate (HPL) price group 1 • High-Pressure Laminate (HPL) price group 3	Specify laminate color number. Specify laminate color number. Specify laminate color number.
Top Surface Type	• Low-Pressure Laminate (LPL) • High-Pressure Laminate (HPL)	Specify <i>with Low-Pressure Laminate</i> . Specify <i>with High-Pressure Laminate</i> .

Specification Information

• Dimensions		• Style	• Modular Depth	
Modular Application Height	Modular Width	Number	15"	24"

Bookcase, Stacking on One-High Currency Low Storage

Low-Pressure Laminate Case

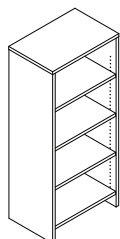
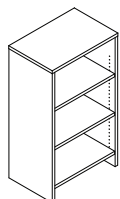
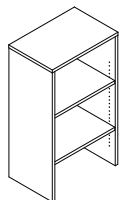

41 ³ / ₄ "	24"	CRBKS1H	•	•
47 ¹⁵ / ₁₆ "	24"	CRBKS1H	•	•
54 ¹ / ₈ "	24"	CRBKS1H	•	•
66 ¹ / ₂ "	24"	CRBKS1H	•	•
72"	24"	CRBKS1H	•	•
78"	24"	CRBKS1H	•	•
84"	24"	CRBKS1H	•	•
41 ³ / ₄ "	30"	CRBKS1H	•	•
47 ¹⁵ / ₁₆ "	30"	CRBKS1H	•	•
54 ¹ / ₈ "	30"	CRBKS1H	•	•
66 ¹ / ₂ "	30"	CRBKS1H	•	•
72"	30"	CRBKS1H	•	•
78"	30"	CRBKS1H	•	•
84"	30"	CRBKS1H	•	•
41 ³ / ₄ "	36"	CRBKS1H	•	•
47 ¹⁵ / ₁₆ "	36"	CRBKS1H	•	•
54 ¹ / ₈ "	36"	CRBKS1H	•	•
66 ¹ / ₂ "	36"	CRBKS1H	•	•
72"	36"	CRBKS1H	•	•
78"	36"	CRBKS1H	•	•
84"	36"	CRBKS1H	•	•

► **Specification Information, continued on next page**

► **Specification Information, continued from previous page**

Specification Information				
Dimensions		Style	Modular Depth	
Modular Application Height	Modular Width	Number	15"	24"

Bookcase, Stacking on One-High Currency Low Storage, continued

High-Pressure Laminate Case

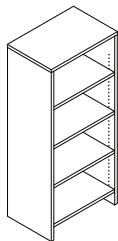
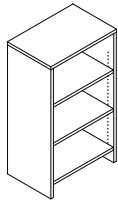
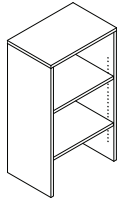

41 ³ / ₄ "	24"	CRBKS1H	•	•
47 ⁵ / ₁₆ "	24"	CRBKS1H	•	•
54 ¹ / ₈ "	24"	CRBKS1H	•	•
66 ¹ / ₂ "	24"	CRBKS1H	•	•
72"	24"	CRBKS1H	•	•
78"	24"	CRBKS1H	•	•
84"	24"	CRBKS1H	•	•
41 ³ / ₄ "	30"	CRBKS1H	•	•
47 ⁵ / ₁₆ "	30"	CRBKS1H	•	•
54 ¹ / ₈ "	30"	CRBKS1H	•	•
66 ¹ / ₂ "	30"	CRBKS1H	•	•
72"	30"	CRBKS1H	•	•
78"	30"	CRBKS1H	•	•
84"	30"	CRBKS1H	•	•
41 ³ / ₄ "	36"	CRBKS1H	•	•
47 ⁵ / ₁₆ "	36"	CRBKS1H	•	•
54 ¹ / ₈ "	36"	CRBKS1H	•	•
66 ¹ / ₂ "	36"	CRBKS1H	•	•
72"	36"	CRBKS1H	•	•
78"	36"	CRBKS1H	•	•
84"	36"	CRBKS1H	•	•
:	:	:	:	:

► **Specification Information, continued on next page**

► Specification Information, continued from previous page

Specification Information				
• Dimensions		• Style	• Modular Depth	
• Modular Application	• Modular Width	• Number	15"	24"
Height				

Bookcase, Stacking on 1.5-High Currency Low Storage

Low-Pressure Laminate Case

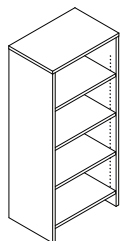
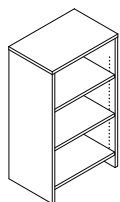
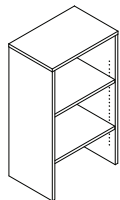

41 ³ / ₄ "	24"	CRBKS15H	•	•
47 ¹⁵ / ₁₆ "	24"	CRBKS15H	•	•
54 ¹ / ₈ "	24"	CRBKS15H	•	•
66 ¹ / ₂ "	24"	CRBKS15H	•	•
72"	24"	CRBKS15H	•	•
78"	24"	CRBKS15H	•	•
84"	24"	CRBKS15H	•	•
41 ³ / ₄ "	30"	CRBKS15H	•	•
47 ¹⁵ / ₁₆ "	30"	CRBKS15H	•	•
54 ¹ / ₈ "	30"	CRBKS15H	•	•
66 ¹ / ₂ "	30"	CRBKS15H	•	•
72"	30"	CRBKS15H	•	•
78"	30"	CRBKS15H	•	•
84"	30"	CRBKS15H	•	•
41 ³ / ₄ "	36"	CRBKS15H	•	•
47 ¹⁵ / ₁₆ "	36"	CRBKS15H	•	•
54 ¹ / ₈ "	36"	CRBKS15H	•	•
66 ¹ / ₂ "	36"	CRBKS15H	•	•
72"	36"	CRBKS15H	•	•
78"	36"	CRBKS15H	•	•
84"	36"	CRBKS15H	•	•

► Specification Information, continued on next page

► **Specification Information, continued from previous page**

Specification Information				
Dimensions		Style	Modular Depth	
Modular Application Height	Modular Width	Number	15"	24"

Bookcase, Stacking on 1.5-High Currency Low Storage, continued

High-Pressure Laminate Case

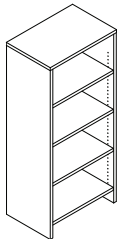
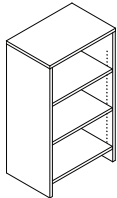
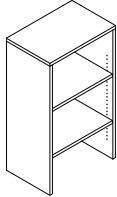

41 ³ / ₄ "	24"	CRBKS15H	•	•
47 ¹⁵ / ₁₆ "	24"	CRBKS15H	•	•
54 ¹ / ₈ "	24"	CRBKS15H	•	•
66 ¹ / ₂ "	24"	CRBKS15H	•	•
72"	24"	CRBKS15H	•	•
78"	24"	CRBKS15H	•	•
84"	24"	CRBKS15H	•	•
41 ³ / ₄ "	30"	CRBKS15H	•	•
47 ¹⁵ / ₁₆ "	30"	CRBKS15H	•	•
54 ¹ / ₈ "	30"	CRBKS15H	•	•
66 ¹ / ₂ "	30"	CRBKS15H	•	•
72"	30"	CRBKS15H	•	•
78"	30"	CRBKS15H	•	•
84"	30"	CRBKS15H	•	•
41 ³ / ₄ "	36"	CRBKS15H	•	•
47 ¹⁵ / ₁₆ "	36"	CRBKS15H	•	•
54 ¹ / ₈ "	36"	CRBKS15H	•	•
66 ¹ / ₂ "	36"	CRBKS15H	•	•
72"	36"	CRBKS15H	•	•
78"	36"	CRBKS15H	•	•
84"	36"	CRBKS15H	•	•
:	:	:	:	:

► **Specification Information, continued on next page**

► Specification Information, continued from previous page

Specification Information				
Dimensions		Style	Modular Depth	
Modular Application	Modular Width	Number	15"	24"
Height				

Bookcase, Stacking on Two-High Currency Low Storage

Low-Pressure Laminate Case

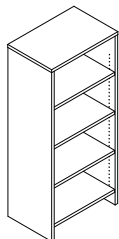
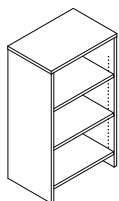
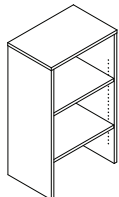

41 ³ / ₄ "	24"	CRBKS2H	•	•
47 ¹⁵ / ₁₆ "	24"	CRBKS2H	•	•
54 ¹ / ₈ "	24"	CRBKS2H	•	•
66 ¹ / ₂ "	24"	CRBKS2H	•	•
72"	24"	CRBKS2H	•	•
78"	24"	CRBKS2H	•	•
84"	24"	CRBKS2H	•	•
41 ³ / ₄ "	30"	CRBKS2H	•	•
47 ¹⁵ / ₁₆ "	30"	CRBKS2H	•	•
54 ¹ / ₈ "	30"	CRBKS2H	•	•
66 ¹ / ₂ "	30"	CRBKS2H	•	•
72"	30"	CRBKS2H	•	•
78"	30"	CRBKS2H	•	•
84"	30"	CRBKS2H	•	•
41 ³ / ₄ "	36"	CRBKS2H	•	•
47 ¹⁵ / ₁₆ "	36"	CRBKS2H	•	•
54 ¹ / ₈ "	36"	CRBKS2H	•	•
66 ¹ / ₂ "	36"	CRBKS2H	•	•
72"	36"	CRBKS2H	•	•
78"	36"	CRBKS2H	•	•
84"	36"	CRBKS2H	•	•
.

► Specification Information, continued on next page

► **Specification Information, continued from previous page**

Specification Information

• Dimensions		• Style	• Modular Depth	
Modular Application Height	Modular Width	Number	15"	24"

Bookcase, Stacking on Two-High Currency Low Storage, continued

High-Pressure Laminate Case

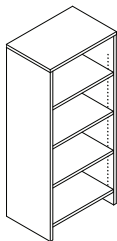
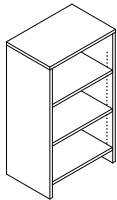
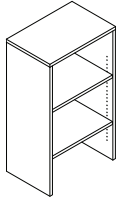

41 ³ / ₄ "	24"	CRBKS2H	•	•
47 ¹⁵ / ₁₆ "	24"	CRBKS2H	•	•
54 ¹ / ₈ "	24"	CRBKS2H	•	•
66 ¹ / ₂ "	24"	CRBKS2H	•	•
72"	24"	CRBKS2H	•	•
78"	24"	CRBKS2H	•	•
84"	24"	CRBKS2H	•	•
41 ³ / ₄ "	30"	CRBKS2H	•	•
47 ¹⁵ / ₁₆ "	30"	CRBKS2H	•	•
54 ¹ / ₈ "	30"	CRBKS2H	•	•
66 ¹ / ₂ "	30"	CRBKS2H	•	•
72"	30"	CRBKS2H	•	•
78"	30"	CRBKS2H	•	•
84"	30"	CRBKS2H	•	•
41 ³ / ₄ "	36"	CRBKS2H	•	•
47 ¹⁵ / ₁₆ "	36"	CRBKS2H	•	•
54 ¹ / ₈ "	36"	CRBKS2H	•	•
66 ¹ / ₂ "	36"	CRBKS2H	•	•
72"	36"	CRBKS2H	•	•
78"	36"	CRBKS2H	•	•
84"	36"	CRBKS2H	•	•
:	:	:	:	:

Currency Overheads

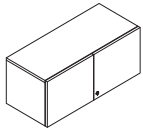

Tip: Overheads with sliding doors do not lock.

Tip: Overheads with three doors will have two doors hinged right. Overheads with four doors will have two doors hinged left, and two hinged right. Doors will always open from the center out.

Tip: White markerboard (2977) headset finish available with sliding doors only.

Tip: Answer beam bracket option includes no brackets. Brackets are specified separately based on specific application.

Tip: Not all attachment brackets are included within the style number.

▶ See Currency Specification Guide.

Tip: If selecting Answer Beam, Answer panel, or top cap mount on Answer attachment brackets, overhead must be modular.

Standard Includes	Required to Specify
<ul style="list-style-type: none"> ▶ See <i>Currency Specification Guide</i> for product details. Overhead: <ul style="list-style-type: none"> – Low-Pressure Laminate case with matching or contrasting Low-Pressure Laminate headset – Low-Pressure Laminate case with High-Pressure Laminate headset, if selected – High-Pressure Laminate case with matching or contrasting High-Pressure Laminate headset, if selected Lock plug on overheads with hinged doors only Shipped fully assembled 	<ol style="list-style-type: none"> Style number Size type (see below under Required Selections) Width (see below under Required Selections) Door surface type (see below under Required Selections) Low-Pressure Laminate or High-Pressure Laminate color number for case Plastic color number for all edges on laminate case Low-Pressure Laminate or High-Pressure Laminate color number for headset Options, if selected (see below) <p>▶ See Surface Materials, page 480.</p>

Required Selections		Required to Specify
Size Type	• Modular	Specify with <i>modular</i> .
Width	<ul style="list-style-type: none"> • 36"W • 42"W • 48"W • 54"W • 60"W • 63"W • 66"W • 69"W • 72"W • 75"W 	Specify 36" width. Specify 42" width. Specify 48" width. Specify 54" width. Specify 60" width. Specify 63" width. Specify 66" width. Specify 69" width. Specify 72" width. Specify 75" width.
Door Surface Type	<ul style="list-style-type: none"> • Laminate • Markerboard 	Specify with <i>laminate</i> . Specify with <i>markerboard</i> .

Pull Shape

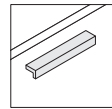

Ledge

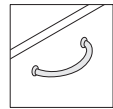

Handle

Options		Required to Specify
Surface Materials	Case <ul style="list-style-type: none"> • Low-Pressure Laminate (LPL) price group 1 • High-Pressure Laminate (HPL) price group 1 • High-Pressure Laminate (HPL) price group 3 	Specify laminate color number. Specify laminate color number. Specify laminate color number.
	Headset <ul style="list-style-type: none"> • Low-Pressure Laminate (LPL) price group 1 • High-Pressure Laminate (HPL) price group 1 • High-Pressure Laminate (HPL) price group 3 	Specify laminate color number. Specify laminate color number. Specify laminate color number.
Attachment Brackets	<ul style="list-style-type: none"> • Answer beam • Top cap mount on Answer • Wall mount brackets <ul style="list-style-type: none"> – 36"W–66"W – 72"W • Answer panel • Answer duo support column • Suspended between towers 	Specify with <i>Answer beam</i> . Specify with <i>top cap mount on Answer</i> . Specify with <i>wall mount brackets 36"W–66"W</i> . Specify with <i>72"W wall mount brackets</i> . Specify with <i>Answer panel</i> . Specify with <i>Answer duo support column</i> . Specify with <i>suspended between towers</i> .
Keys	<ul style="list-style-type: none"> • Key plug • Master key plug 	Specify with <i>key plug</i> . Specify with <i>master key plug</i> .

Specification Information

Dimensions Modular D Width	H	Style Number	LPL Case	HPL Case	HPL Case	Option
			LPL Headset	HPL Headset	HPL Headset	Markerboard Door

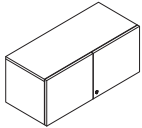

Overhead with Hinged Doors

36"	16"	15"	CROHHD	•	•	•	N.A.
42"	16"	15"	CROHHD	•	•	•	N.A.
48"	16"	15"	CROHHD	•	•	•	N.A.
54"	16"	15"	CROHHD	•	•	•	N.A.
60"	16"	15"	CROHHD	•	•	•	N.A.
66"	16"	15"	CROHHD	•	•	•	N.A.
72"	16"	15"	CROHHD	•	•	•	N.A.

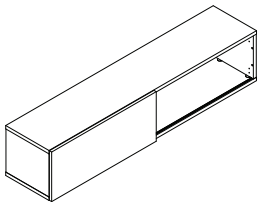

Overhead—Sliding Doors, Personal

36"	16"	15"	CROHSDP	•	•	•	•
42"	16"	15"	CROHSDP	•	•	•	•
48"	16"	15"	CROHSDP	•	•	•	•
54"	16"	15"	CROHSDP	•	•	•	•
60"	16"	15"	CROHSDP	•	•	•	•
66"	16"	15"	CROHSDP	•	•	•	•
72"	16"	15"	CROHSDP	•	•	•	•

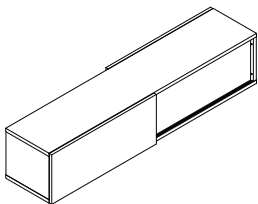

Overhead—Sliding Doors, Shared

36"	16"	15"	CROHSDS	•	•	•	•
42"	16"	15"	CROHSDS	•	•	•	•
48"	16"	15"	CROHSDS	•	•	•	•
54"	16"	15"	CROHSDS	•	•	•	•
60"	16"	15"	CROHSDS	•	•	•	•
66"	16"	15"	CROHSDS	•	•	•	•
72"	16"	15"	CROHSDS	•	•	•	•

► Specification Information, continued on next page

► Specification Information, continued from previous page

Specification Information

• Dimensions Modular D Width	H	• Style Number	• LPL Case	• HPL Case
------------------------------------	---	-------------------	---------------	---------------

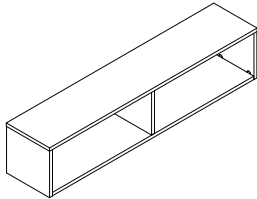

Overhead—No Doors, Open, Personal

36"	15"	15"	CROHOP	•	•
42"	15"	15"	CROHOP	•	•
48"	15"	15"	CROHOP	•	•
54"	15"	15"	CROHOP	•	•
60"	15"	15"	CROHOP	•	•
66"	15"	15"	CROHOP	•	•
72"	15"	15"	CROHOP	•	•
:	:	:	:	:	:

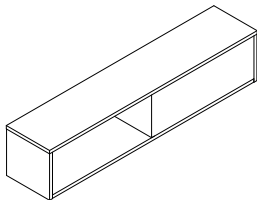

Overhead—No Doors, Open, Shared

36"	15"	15"	CROHOS	•	•
42"	15"	15"	CROHOS	•	•
48"	15"	15"	CROHOS	•	•
54"	15"	15"	CROHOS	•	•
60"	15"	15"	CROHOS	•	•
66"	15"	15"	CROHOS	•	•
72"	15"	15"	CROHOS	•	•
:	:	:	:	:	:

Currency Stacking Overheads

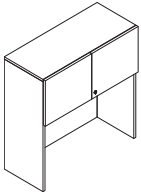

Tip: Stacking overheads with sliding doors do not lock.

Tip: Stacking overheads with three doors will have two doors hinged right. Overheads with four doors will have two doors hinged left, and two hinged right. Doors will always open from the center out.

Tip: Stacking overheads go on top of Two-High Currency storage or desks. Please specify the application height of the overall height desired with storage and stacking overhead combined.

Tip: Selecting the correct worksurface thickness and top surface materiality type (Low-Pressure Laminate or High-Pressure Laminate) of storage underneath ensures that the stacking overhead aligns with neighboring tall storage.

Tip: White markerboard (2977) headset finish available with sliding doors only.

Tip: 15"H refers to the height of the storage case.

Standard Includes	Required to Specify
<ul style="list-style-type: none"> ▶ See <i>Currency Specification Guide</i> for product details. • Stacking overhead: <ul style="list-style-type: none"> – Low-Pressure Laminate case with matching or contrasting Low-Pressure Laminate headset – Low-Pressure Laminate case with High-Pressure Laminate headset, if selected – High-Pressure Laminate case with matching or contrasting High-Pressure Laminate headset, if selected • Lock plug on overheads with hinged doors only • 1 1/8" thick top: Low-Pressure Laminate • Attachment hardware 	<ol style="list-style-type: none"> 1 Style number 2 Size type (see below under Required Selections) 3 Application height (see below under Required Selections) 3 Width (see below under Required Selections) 4 Door surface type (see below under Required Selections) 5 Low-Pressure Laminate or High-Pressure Laminate color number for case 6 Plastic color number for all edges on laminate case 7 Low-Pressure Laminate or High-Pressure Laminate color number for headset 8 Pulls (see below under Required Selections) 9 Options, if selected (see below) <p>▶ See <i>Surface Materials</i>, page 480.</p>

Required Selections		Required to Specify
Size Type	• Modular	Specify <i>with modular</i> .
Application Height	• 66 1/2"H • 72"H	Specify 66 1/2" height. Specify 72" height.
Width	• 36"W • 42"W • 48"W • 54"W • 60"W • 66"W • 72"W	Specify 36" width. Specify 42" width. Specify 48" width. Specify 54" width. Specify 60" width. Specify 66" width. Specify 72" width.
Door Surface Type	• Laminate • Markerboard	Specify <i>with laminate</i> . Specify <i>with markerboard</i> .

Pull Shape

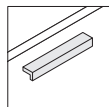

Ledge

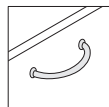

Handle

Options		Required to Specify
Surface Materials	Case <ul style="list-style-type: none"> • Low-Pressure Laminate (LPL) price group 1 • High-Pressure Laminate (HPL) price group 1 • High-Pressure Laminate (HPL) price group 3 Headset <ul style="list-style-type: none"> • Low-Pressure Laminate (LPL) price group 1 • High-Pressure Laminate (HPL) price group 1 • High-Pressure Laminate (HPL) price group 3 	Specify laminate color number. Specify laminate color number. Specify laminate color number.
Tackboard	• No tackboard • With tackboard	Specify <i>with no tackboard</i> . Specify <i>with tackboard</i> .
Valance	• No light valance • With light valance	Specify <i>with no light valance</i> . Specify <i>with light valance</i> .
Top Surface Type	• Low-Pressure Laminate (LPL) • High-Pressure Laminate (HPL)	Specify <i>with Low-Pressure Laminate</i> . Specify <i>with High-Pressure Laminate</i> .
Keys	• Key plug • Master key plug	Specify <i>with key plug</i> . Specify <i>with master key plug</i> .

Specification Information

• Dimensions		• Modular	• Style	• LPL		• HPL	• Options
Modular	Depth	App	Number	Case		Case	
Width		Height		LPL	HPL	HPL	Markerboard
				Headset	Headset	Headset	Door

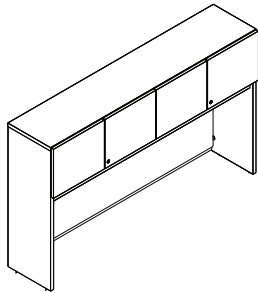

Stacking Overhead—Hinged Doors

36"	16"	66½"	CROHSHD	•	•	•	N.A.
42"	16"	66½"	CROHSHD	•	•	•	N.A.
48"	16"	66½"	CROHSHD	•	•	•	N.A.
54"	16"	66½"	CROHSHD	•	•	•	N.A.
60"	16"	66½"	CROHSHD	•	•	•	N.A.
66"	16"	66½"	CROHSHD	•	•	•	N.A.
72"	16"	66½"	CROHSHD	•	•	•	N.A.
36"	16"	72"	CROHSHD	•	•	•	N.A.
42"	16"	72"	CROHSHD	•	•	•	N.A.
48"	16"	72"	CROHSHD	•	•	•	N.A.
54"	16"	72"	CROHSHD	•	•	•	N.A.
60"	16"	72"	CROHSHD	•	•	•	N.A.
66"	16"	72"	CROHSHD	•	•	•	N.A.
72"	16"	72"	CROHSHD	•	•	•	N.A.
:	:	:	:	:	:	:	:

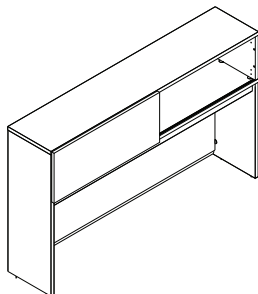

Stacking Overhead—Sliding Doors

36"	16"	66½"	CROHSSD	•	•	•	•
42"	16"	66½"	CROHSSD	•	•	•	•
48"	16"	66½"	CROHSSD	•	•	•	•
54"	16"	66½"	CROHSSD	•	•	•	•
60"	16"	66½"	CROHSSD	•	•	•	•
66"	16"	66½"	CROHSSD	•	•	•	•
72"	16"	66½"	CROHSSD	•	•	•	•
36"	16"	72"	CROHSSD	•	•	•	•
42"	16"	72"	CROHSSD	•	•	•	•
48"	16"	72"	CROHSSD	•	•	•	•
54"	16"	72"	CROHSSD	•	•	•	•
60"	16"	72"	CROHSSD	•	•	•	•
66"	16"	72"	CROHSSD	•	•	•	•
72"	16"	72"	CROHSSD	•	•	•	•
:	:	:	:	:	:	:	:

► Specification Information, continued on next page

► Specification Information, continued from previous page

Specification Information

Dimensions Modular Width	D	H	Modular Number	LPL Case	HPL Case
--------------------------------	---	---	-------------------	-------------	-------------

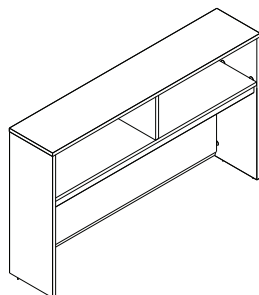

Stacking Overhead—No Doors, Open

36"	15"	66½"	CROHSO	•	•
42"	15"	66½"	CROHSO	•	•
48"	15"	66½"	CROHSO	•	•
54"	15"	66½"	CROHSO	•	•
60"	15"	66½"	CROHSO	•	•
66"	15"	66½"	CROHSO	•	•
72"	15"	66½"	CROHSO	•	•
36"	15"	72"	CROHSO	•	•
42"	15"	72"	CROHSO	•	•
48"	15"	72"	CROHSO	•	•
54"	15"	72"	CROHSO	•	•
60"	15"	72"	CROHSO	•	•
66"	15"	72"	CROHSO	•	•
72"	15"	72"	CROHSO	•	•

Currency Organizers

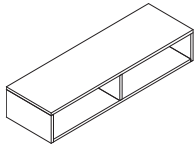

Standard Includes	Required to Specify
<ul style="list-style-type: none"> ▶ See <i>Currency Specification Guide</i> for product details. • Organizer: <ul style="list-style-type: none"> – Low-Pressure Laminate case, price group 1 – High-Pressure Laminate case, price group 1, if selected 	<ol style="list-style-type: none"> 1 Style number 2 Size type (see below under Required Selections) 4 Width (see below under Required Selections) 5 Low-Pressure Laminate color number for case 6 Plastic color number for all edges on laminate case 7 Options, if selected (see below) <p>▶ See <i>Surface Materials</i>, page 480.</p>

Required Selections		Required to Specify
Size Type	<ul style="list-style-type: none"> • Modular 	Specify <i>with modular</i> .
Width	<ul style="list-style-type: none"> • 36"W • 42"W • 48"W • 54"W • 60"W • 66"W • 72"W 	Specify 36" width. Specify 42" width. Specify 48" width. Specify 54" width. Specify 60" width. Specify 66" width. Specify 72" width.

Options		Required to Specify
Surface Materials	Case <ul style="list-style-type: none"> • Low-Pressure Laminate (LPL) price group 1 • High-Pressure Laminate (HPL) price group 1 • High-Pressure Laminate (HPL) price group 3 	Specify laminate color number. Specify laminate color number. Specify laminate color number.
Attachment Brackets	<ul style="list-style-type: none"> • Answer beam • Suspended between towers • Top cap mount on Answer • Wall mount brackets <ul style="list-style-type: none"> – 36"W–66"W – 72"W • Answer panel • Answer duo support column 	Specify <i>with Answer beam</i> . Specify <i>with suspended between towers</i> . Specify <i>with top cap mount on Answer</i> . Specify <i>with wall mount brackets 36"W–66"W</i> . Specify <i>with 72"W wall mount brackets</i> . Specify <i>with Answer panel</i> . Specify <i>with Answer duo support column</i> .

Tip: For appropriate use of Answer Beam, mid-storage, and stanchion supports, see Answer Beam and Answer Fence Specification Guide.

Tip: Not all attachment brackets are included within the style number.

Specification Information

Dimensions Modular D Width	H	Modular Number	LPL Case	HPL Case
----------------------------------	---	-------------------	-------------	-------------

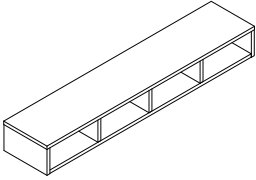

Organizer—Personal

36"	15"	8 ²⁷ / ₃₂ "	CROP	•	•
42"	15"	8 ²⁷ / ₃₂ "	CROP	•	•
48"	15"	8 ²⁷ / ₃₂ "	CROP	•	•
54"	15"	8 ²⁷ / ₃₂ "	CROP	•	•
60"	15"	8 ²⁷ / ₃₂ "	CROP	•	•
66"	15"	8 ²⁷ / ₃₂ "	CROP	•	•
72"	15"	8 ²⁷ / ₃₂ "	CROP	•	•
:	:	:	:	:	:

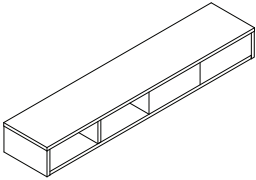

Organizer—Shared

36"	15"	8 ²⁷ / ₃₂ "	CROS	•	•
42"	15"	8 ²⁷ / ₃₂ "	CROS	•	•
48"	15"	8 ²⁷ / ₃₂ "	CROS	•	•
54"	15"	8 ²⁷ / ₃₂ "	CROS	•	•
60"	15"	8 ²⁷ / ₃₂ "	CROS	•	•
66"	15"	8 ²⁷ / ₃₂ "	CROS	•	•
72"	15"	8 ²⁷ / ₃₂ "	CROS	•	•
:	:	:	:	:	:

Currency Tackboards

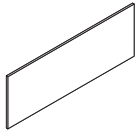

Standard Includes	Required to Specify
<ul style="list-style-type: none"> ▶ See <i>Currency Specification Guide</i> for product details. Tackboard: fabric price group A Attachment hardware 	<ol style="list-style-type: none"> Style number Size type (see below under Required Selections) Height (see below under Required Selections) Width (see below under Required Selections) Fabric color number for tackboard Options, if selected (see below) <ul style="list-style-type: none"> ▶ See <i>Surface Materials</i>, page 480.

Tip: Dimensions shown are modular sizes.

Required Selections		Required to Specify
Size Type	<ul style="list-style-type: none"> Modular 	Specify with modular.
Height	<ul style="list-style-type: none"> 20¼"H 26¼"H 	Specify 20¼" height. Specify 26¼" height.
Width	<ul style="list-style-type: none"> 36"W 42"W 48"W 54"W 60"W 66"W 72"W 	Specify 36" width. Specify 42" width. Specify 48" width. Specify 54" width. Specify 60" width. Specify 66" width. Specify 72" width.

Tip: Vertical application only available on 36"W–60"W.

Tip: Tackboards cannot be attached to walls covered by textured paint or wallpaper.

Options		Required to Specify
Surface Materials	<ul style="list-style-type: none"> Fabric price group A Fabric price group 1 Fabric price group 2 Fabric price group 3 	Specify with fabric price group A. Specify with fabric price group 1. Specify with fabric price group 2. Specify with fabric price group 3.
Fabric Direction	<ul style="list-style-type: none"> Horizontal Vertical 	Specify with horizontal direction. Specify with vertical direction.

Specification Information										
Height	Style Number	Width								
		24"	30"	36"	42"	48"	54"	60"	66"	72"
20¼"	CRTBWM	•	•	•	•	•	•	•	•	•
26¼"	CRTBWM	•	•	•	•	•	•	•	•	•

Currency Single-Door Towers

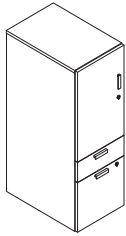

	Standard Includes	Required to Specify
▶ See <i>Currency Specification Guide</i> for product details.	<ul style="list-style-type: none"> 15.906"W single-door tower: <ul style="list-style-type: none"> – Low-Pressure Laminate case with matching or contrasting Low-Pressure Laminate headset – Low-Pressure Laminate case with High-Pressure Laminate headset, if selected – High-Pressure Laminate case with matching or contrasting High-Pressure Laminate headset, if selected 1" thick top: laminate to match case Lock plug Two counterweights 1¼" leveling glides Shipped fully assembled Bore and dowel drawer construction: black Shelf(s) in tower side depending on height 	<ol style="list-style-type: none"> Style number Size type (see below under Required Selections) Depth (see below under Required Selections) Height (see below under Required Selections) Low-Pressure Laminate or High-Pressure Laminate color number for case Plastic color number for all edges on laminate case Low-Pressure Laminate or High-Pressure Laminate color number for headset Pulls (see below under Required Selections) Options, if selected (see below) ▶ See <i>Surface Materials</i> , page 480.

	Required Selections	Required to Specify
Size Type	<ul style="list-style-type: none"> Modular 	Specify <i>with modular</i> .
Depth	<ul style="list-style-type: none"> 18⁷/₈"D 24"D 	Specify 18 ⁷ / ₈ " depth. Specify 24" depth.
Height	<ul style="list-style-type: none"> 41³/₄"H 47¹⁵/₁₆"H 54¹/₈"H 66¹/₂"H 	Specify 41 ³ / ₄ " height. Specify 47 ¹⁵ / ₁₆ " height. Specify 54 ¹ / ₈ " height. Specify 66 ¹ / ₂ " height.

Tip: Shelf count (tower side) depends on height of unit.

▶ Tower and Cabinet Interior Configurations, See *Currency Specification Guide*.

Pull Shape

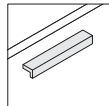

Ledge

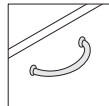

Handle

	Options	Required to Specify
Surface Materials	Case <ul style="list-style-type: none"> Low-Pressure Laminate (LPL) price group 1 High-Pressure Laminate (HPL) price group 1 High-Pressure Laminate (HPL) price group 3 	Specify laminate color number. Specify laminate color number. Specify laminate color number
	Headset <ul style="list-style-type: none"> Low-Pressure Laminate (LPL) price group 1 High-Pressure Laminate (HPL) price group 1 High-Pressure Laminate (HPL) price group 3 	Specify laminate color number. Specify laminate color number. Specify laminate color number.
Pulls	<ul style="list-style-type: none"> Handle Ledge 	Specify <i>with handle pull</i> . Specify <i>with ledge pull</i> .
Keys	<ul style="list-style-type: none"> Key plug Master key plug 	Specify <i>with key plug</i> . Specify <i>with master key plug</i> .

Specification Information

Modular Height	Modular Width	Style Number	Modular Depth	
			18 ⁷ / ₈ "	24"

Single Door Tower—One Box Drawer, One File Drawer

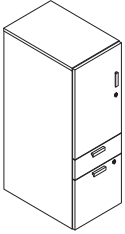

Hinged Left, Low-Pressure Laminate Case with Headset

41 ³ / ₄ "	15.906"	CRTWBFL	•	•
47 ¹⁵ / ₁₆ "	15.906"	CRTWBFL	•	•
54 ¹ / ₈ "	15.906"	CRTWBFL	•	•
66 ¹ / ₂ "	15.906"	CRTWBFL	•	•

Hinged Left, Low-Pressure Laminate Case with High-Pressure Laminate Headset

41 ³ / ₄ "	15.906"	CRTWBFL	•	•
47 ¹⁵ / ₁₆ "	15.906"	CRTWBFL	•	•
54 ¹ / ₈ "	15.906"	CRTWBFL	•	•
66 ¹ / ₂ "	15.906"	CRTWBFL	•	•

Hinged Left, High-Pressure Laminate Case with Headset

41 ³ / ₄ "	15.906"	CRTWBFL	•	•
47 ¹⁵ / ₁₆ "	15.906"	CRTWBFL	•	•
54 ¹ / ₈ "	15.906"	CRTWBFL	•	•
66 ¹ / ₂ "	15.906"	CRTWBFL	•	•

Hinged Right, Low-Pressure Laminate Case with Headset

41 ³ / ₄ "	15.906"	CRTWBFR	•	•
47 ¹⁵ / ₁₆ "	15.906"	CRTWBFR	•	•
54 ¹ / ₈ "	15.906"	CRTWBFR	•	•
66 ¹ / ₂ "	15.906"	CRTWBFR	•	•

Hinged Right, Low-Pressure Laminate Case with High-Pressure Laminate Headset

41 ³ / ₄ "	15.906"	CRTWBFR	•	•
47 ¹⁵ / ₁₆ "	15.906"	CRTWBFR	•	•
54 ¹ / ₈ "	15.906"	CRTWBFR	•	•
66 ¹ / ₂ "	15.906"	CRTWBFR	•	•

Hinged Right, High-Pressure Laminate Case with Headset

41 ³ / ₄ "	15.906"	CRTWBFR	•	•
47 ¹⁵ / ₁₆ "	15.906"	CRTWBFR	•	•
54 ¹ / ₈ "	15.906"	CRTWBFR	•	•
66 ¹ / ₂ "	15.906"	CRTWBFR	•	•

► **Specification Information, continued on next page**

► **Specification Information, continued from previous page**

Specification Information

Modular Height	Modular Width	Style Number	Modular Depth	
			18 ⁷ / ₈ "	24"

Single Door Tower—Two File Drawers

Hinged Left, Low-Pressure Laminate Case with Headset

41 ³ / ₄ "	15.906"	CRTWFFL	•	•
47 ¹⁵ / ₁₆ "	15.906"	CRTWFFL	•	•
54 ¹ / ₈ "	15.906"	CRTWFFL	•	•
66 ¹ / ₂ "	15.906"	CRTWFFL	•	•

Hinged Left, Low-Pressure Laminate Case with High-Pressure Laminate Headset

41 ³ / ₄ "	15.906"	CRTWFFL	•	•
47 ¹⁵ / ₁₆ "	15.906"	CRTWFFL	•	•
54 ¹ / ₈ "	15.906"	CRTWFFL	•	•
66 ¹ / ₂ "	15.906"	CRTWFFL	•	•

Hinged Left, High-Pressure Laminate Case with Headset

41 ³ / ₄ "	15.906"	CRTWFFL	•	•
47 ¹⁵ / ₁₆ "	15.906"	CRTWFFL	•	•
54 ¹ / ₈ "	15.906"	CRTWFFL	•	•
66 ¹ / ₂ "	15.906"	CRTWFFL	•	•

Hinged Right, Low-Pressure Laminate Case with Headset

41 ³ / ₄ "	15.906"	CRTWFFR	•	•
47 ¹⁵ / ₁₆ "	15.906"	CRTWFFR	•	•
54 ¹ / ₈ "	15.906"	CRTWFFR	•	•
66 ¹ / ₂ "	15.906"	CRTWFFR	•	•

Hinged Right, Low-Pressure Laminate Case with High-Pressure Laminate Headset

41 ³ / ₄ "	15.906"	CRTWFFR	•	•
47 ¹⁵ / ₁₆ "	15.906"	CRTWFFR	•	•
54 ¹ / ₈ "	15.906"	CRTWFFR	•	•
66 ¹ / ₂ "	15.906"	CRTWFFR	•	•

Hinged Right, High-Pressure Laminate Case with Headset

41 ³ / ₄ "	15.906"	CRTWFFR	•	•
47 ¹⁵ / ₁₆ "	15.906"	CRTWFFR	•	•
54 ¹ / ₈ "	15.906"	CRTWFFR	•	•
66 ¹ / ₂ "	15.906"	CRTWFFR	•	•

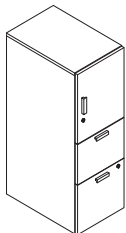
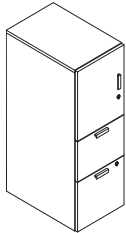

Currency Dual-Door Towers

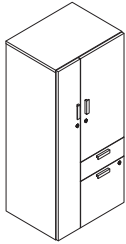

Left-hand unit

	Standard Includes	Required to Specify
▶ See <i>Currency Specification Guide</i> for product details.	<ul style="list-style-type: none"> • 24"W dual-door tower: <ul style="list-style-type: none"> – Low-Pressure Laminate case with matching or contrasting Low-Pressure Laminate headset – Low-Pressure Laminate case with High-Pressure Laminate headset, if selected – High-Pressure Laminate case with matching or contrasting High-Pressure Laminate headset, if selected • 1" thick top: laminate to match case • Lock plug • Two counterweights • 1¼" leveling glides • Shipped fully assembled • Fixed top shelf in cabinet on units 66½"H and taller • Shelf(s) in tower side depending on height 	<ol style="list-style-type: none"> 1 Style number 2 Size type (see below under Required Selections) 3 Depth (see below under Required Selections) 4 Height (see below under Required Selections) 5 Interior configuration (see below under Required Selections) 6 Low-Pressure Laminate or High-Pressure Laminate color number for case 7 Plastic color number for all edges on laminate case 8 Low-Pressure Laminate or High-Pressure Laminate color number for headset 9 Pulls (see below under Required Selections) 10 Options, if selected (see below) <p>▶ See <i>Surface Materials</i>, page 480.</p>

Tip: Shelf count (tower side) depends on height of unit.

▶ Tower and Cabinet Interior Configurations, See *Currency Specification Guide*.

Tip: Coat rods available on 24"D units.

	Required Selections	Required to Specify
Size Type	<ul style="list-style-type: none"> • Modular 	Specify <i>with modular</i> .
Depth	<ul style="list-style-type: none"> • 18⅞"D • 24"D 	Specify 18⅞" depth. Specify 24" depth.
Height	<ul style="list-style-type: none"> • 41¾"H • 47⅙/16"H • 54⅙/8"H • 66½"H 	Specify 41¾" height. Specify 47⅙/16" height. Specify 54⅙/8" height. Specify 66½" height.
Interior Configuration	<ul style="list-style-type: none"> • Coat hook • Coat rod 	Specify <i>with coat hook</i> . Specify <i>with coat rod</i> .

Pull Shape

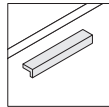

Ledge

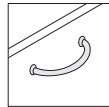

Handle

	Options	Required to Specify
Surface Materials	Case <ul style="list-style-type: none"> • Low-Pressure Laminate (LPL) price group 1 • High-Pressure Laminate (HPL) price group 1 • High-Pressure Laminate (HPL) price group 3 	Specify laminate color number. Specify laminate color number. Specify laminate color number.
	Headset <ul style="list-style-type: none"> • Low-Pressure Laminate (LPL) price group 1 • High-Pressure Laminate (HPL) price group 1 • High-Pressure Laminate (HPL) price group 3 	Specify laminate color number. Specify laminate color number. Specify laminate color number.
Pulls	<ul style="list-style-type: none"> • Handle • Ledge 	Specify <i>with handle pull</i> . Specify <i>with ledge pull</i> .
Keys	<ul style="list-style-type: none"> • Key plug • Master key plug 	Specify <i>with key plug</i> . Specify <i>with master key plug</i> .

Specification Information

Modular Height	Modular Width	Style Number	Modular Depth	
			18 ⁷ / ₈ "	24"

Dual Door Tower—One Box Drawer, One File Drawer

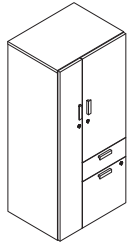

Left-hand unit

Cabinet Left, Low-Pressure Laminate Case with Headset

41 ³ / ₄ "	24"	CRTWDBFL	•	•
47 ¹⁵ / ₁₆ "	24"	CRTWDBFL	•	•
54 ¹ / ₈ "	24"	CRTWDBFL	•	•
66 ¹ / ₂ "	24"	CRTWDBFL	•	•

Cabinet Left, Low-Pressure Laminate Case with High-Pressure Laminate Headset

41 ³ / ₄ "	24"	CRTWDBFL	•	•
47 ¹⁵ / ₁₆ "	24"	CRTWDBFL	•	•
54 ¹ / ₈ "	24"	CRTWDBFL	•	•
66 ¹ / ₂ "	24"	CRTWDBFL	•	•

Cabinet Left, High-Pressure Laminate Case with Headset

41 ³ / ₄ "	24"	CRTWDBFL	•	•
47 ¹⁵ / ₁₆ "	24"	CRTWDBFL	•	•
54 ¹ / ₈ "	24"	CRTWDBFL	•	•
66 ¹ / ₂ "	24"	CRTWDBFL	•	•

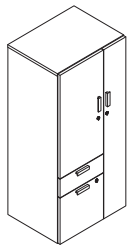

Right-hand unit

Cabinet Right, Low-Pressure Laminate Case with Headset

41 ³ / ₄ "	24"	CRTWDBFR	•	•
47 ¹⁵ / ₁₆ "	24"	CRTWDBFR	•	•
54 ¹ / ₈ "	24"	CRTWDBFR	•	•
66 ¹ / ₂ "	24"	CRTWDBFR	•	•

Cabinet Right, Low-Pressure Laminate Case with High-Pressure Laminate Headset

41 ³ / ₄ "	24"	CRTWDBFR	•	•
47 ¹⁵ / ₁₆ "	24"	CRTWDBFR	•	•
54 ¹ / ₈ "	24"	CRTWDBFR	•	•
66 ¹ / ₂ "	24"	CRTWDBFR	•	•

Cabinet Right, High-Pressure Laminate Case with Headset

41 ³ / ₄ "	24"	CRTWDBFR	•	•
47 ¹⁵ / ₁₆ "	24"	CRTWDBFR	•	•
54 ¹ / ₈ "	24"	CRTWDBFR	•	•
66 ¹ / ₂ "	24"	CRTWDBFR	•	•

► Specification Information, continued on next page

► Specification Information, continued from previous page

Specification Information				
Modular Height	Modular Width	Style Number	Modular Depth	
			18 ⁷ / ₈ "	24"

Dual Door Tower—Two File Drawers

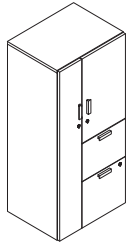

Left-hand unit

Cabinet Left, Low-Pressure Laminate Case with Headset

41 ³ / ₄ "	24"	CRTWDFFL	•	•
47 ¹⁵ / ₁₆ "	24"	CRTWDFFL	•	•
54 ¹ / ₈ "	24"	CRTWDFFL	•	•
66 ¹ / ₂ "	24"	CRTWDFFL	•	•

Cabinet Left, Low-Pressure Laminate Case with High-Pressure Laminate Headset

41 ³ / ₄ "	24"	CRTWDFFL	•	•
47 ¹⁵ / ₁₆ "	24"	CRTWDFFL	•	•
54 ¹ / ₈ "	24"	CRTWDFFL	•	•
66 ¹ / ₂ "	24"	CRTWDFFL	•	•

Cabinet Left, High-Pressure Laminate Case with Headset

41 ³ / ₄ "	24"	CRTWDFFL	•	•
47 ¹⁵ / ₁₆ "	24"	CRTWDFFL	•	•
54 ¹ / ₈ "	24"	CRTWDFFL	•	•
66 ¹ / ₂ "	24"	CRTWDFFL	•	•

Cabinet Right, Low-Pressure Laminate Case with Headset

41 ³ / ₄ "	24"	CRTWDFFR	•	•
47 ¹⁵ / ₁₆ "	24"	CRTWDFFR	•	•
54 ¹ / ₈ "	24"	CRTWDFFR	•	•
66 ¹ / ₂ "	24"	CRTWDFFR	•	•

Cabinet Right, Low-Pressure Laminate Case with High-Pressure Laminate Headset

41 ³ / ₄ "	24"	CRTWDFFR	•	•
47 ¹⁵ / ₁₆ "	24"	CRTWDFFR	•	•
54 ¹ / ₈ "	24"	CRTWDFFR	•	•
66 ¹ / ₂ "	24"	CRTWDFFR	•	•

Cabinet Right, High-Pressure Laminate Case with Headset

41 ³ / ₄ "	24"	CRTWDFFR	•	•
47 ¹⁵ / ₁₆ "	24"	CRTWDFFR	•	•
54 ¹ / ₈ "	24"	CRTWDFFR	•	•
66 ¹ / ₂ "	24"	CRTWDFFR	•	•

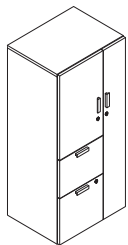

Right-hand unit

Currency Side Access Towers

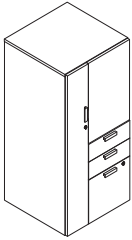

Left-hand unit

	Standard Includes	Required to Specify
▶ See <i>Currency Specification Guide</i> for product details.	<ul style="list-style-type: none"> • 24"D x 24"W side access tower: <ul style="list-style-type: none"> – Low-Pressure Laminate case with matching or contrasting Low-Pressure Laminate headset – Low-Pressure Laminate case with High-Pressure Laminate headset, if selected – High-Pressure Laminate case with matching or contrasting High-Pressure Laminate headset, if selected • 1" thick top: laminate to match case • Lock plug • Two counterweights • 1¹/₄" leveling glides • Shipped fully assembled • Fixed top shelf in cabinet on units 66¹/₂"H and taller • Shelf(s) in tower side depending on height 	<ol style="list-style-type: none"> 1 Style number 2 Size type (see below under Required Selections) 3 Height (see below under Required Selections) 4 Interior configuration (see below under Required Selections) 5 Low-Pressure Laminate or High-Pressure Laminate color number for case 6 Plastic color number for all edges on laminate case 7 Low-Pressure Laminate or High-Pressure Laminate color number for headset 8 Pulls (see below under Required Selections) 9 Options, if selected (see below) <p>▶ See <i>Surface Materials</i>, page 480.</p>

Tip: Shelf count (tower side) depends on height of unit.
▶ Tower and Cabinet Interior Configurations, See *Currency Specification Guide*.

Tip: Coat rods available on 24"D units.

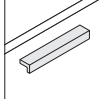
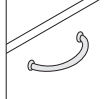
	Required Selections	Required to Specify
Size Type	• Modular	Specify <i>with modular</i> .
Height	<ul style="list-style-type: none"> • 41³/₄"H • 47¹⁵/₁₆"H • 54¹/₈"H • 66¹/₂"H 	Specify 41 ³ / ₄ " height. Specify 47 ¹⁵ / ₁₆ " height. Specify 54 ¹ / ₈ " height. Specify 66 ¹ / ₂ " height.
Interior Configuration	<ul style="list-style-type: none"> • Coat hook • Coat rod 	Specify <i>with coat hook</i> . Specify <i>with coat rod</i> .
Pull Shape	 	
	Ledge	Handle

	Options	Required to Specify
Surface Materials	<p>Case</p> <ul style="list-style-type: none"> • Low-Pressure Laminate (LPL) price group 1 • High-Pressure Laminate (HPL) price group 1 • High-Pressure Laminate (HPL) price group 3 <p>Headset</p> <ul style="list-style-type: none"> • Low-Pressure Laminate (LPL) price group 1 • High-Pressure Laminate (HPL) price group 1 • High-Pressure Laminate (HPL) price group 3 	Specify laminate color number. Specify laminate color number. Specify laminate color number.
Pulls	<ul style="list-style-type: none"> • Handle • Ledge 	Specify <i>with handle pull</i> . Specify <i>with ledge pull</i> .
Keys	<ul style="list-style-type: none"> • Key plug • Master key plug 	Specify <i>with key plug</i> . Specify <i>with master key plug</i> .

Specification Information

Modular Height	Modular Width	Style Number
----------------	---------------	--------------

Side Access Tower—Two Box Drawers and One File Drawer

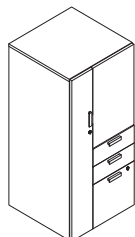

Left-hand unit

Cabinet Left, Low-Pressure Laminate Case with Headset

41 ³ / ₄ "	24"	CRTWSABBFL
47 ¹⁵ / ₁₆ "	24"	CRTWSABBFL
54 ¹ / ₈ "	24"	CRTWSABBFL
66 ¹ / ₂ "	24"	CRTWSABBFL

Cabinet Left, Low-Pressure Laminate Case with High-Pressure Laminate Headset

41 ³ / ₄ "	24"	CRTWSABBFL
47 ¹⁵ / ₁₆ "	24"	CRTWSABBFL
54 ¹ / ₈ "	24"	CRTWSABBFL
66 ¹ / ₂ "	24"	CRTWSABBFL

Cabinet Left, High-Pressure Laminate Case with Headset

41 ³ / ₄ "	24"	CRTWSABBFL
47 ¹⁵ / ₁₆ "	24"	CRTWSABBFL
54 ¹ / ₈ "	24"	CRTWSABBFL
66 ¹ / ₂ "	24"	CRTWSABBFL

Cabinet Right, Low-Pressure Laminate Case with Headset

41 ³ / ₄ "	24"	CRTWSABBFR
47 ¹⁵ / ₁₆ "	24"	CRTWSABBFR
54 ¹ / ₈ "	24"	CRTWSABBFR
66 ¹ / ₂ "	24"	CRTWSABBFR

Cabinet Right, Low-Pressure Laminate Case with High-Pressure Laminate Headset

41 ³ / ₄ "	24"	CRTWSABBFR
47 ¹⁵ / ₁₆ "	24"	CRTWSABBFR
54 ¹ / ₈ "	24"	CRTWSABBFR
66 ¹ / ₂ "	24"	CRTWSABBFR

Cabinet Right, High-Pressure Laminate Case with Headset

41 ³ / ₄ "	24"	CRTWSABBFR
47 ¹⁵ / ₁₆ "	24"	CRTWSABBFR
54 ¹ / ₈ "	24"	CRTWSABBFR
66 ¹ / ₂ "	24"	CRTWSABBFR

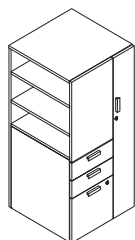

Right-hand unit

► **Specification Information, continued on next page**

► **Specification Information, continued from previous page**

Specification Information

Modular Height	Modular Width	Style Number
----------------	---------------	--------------

Side Access Tower—Two File Drawers

Cabinet Left, Low-Pressure Laminate Case with Headset

41 ³ / ₄ "	24"	CRTWSAFFL
47 ¹⁵ / ₁₆ "	24"	CRTWSAFFL
54 ¹ / ₈ "	24"	CRTWSAFFL
66 ¹ / ₂ "	24"	CRTWSAFFL

Cabinet Left, Low-Pressure Laminate Case with High-Pressure Laminate Headset

41 ³ / ₄ "	24"	CRTWSAFFL
47 ¹⁵ / ₁₆ "	24"	CRTWSAFFL
54 ¹ / ₈ "	24"	CRTWSAFFL
66 ¹ / ₂ "	24"	CRTWSAFFL

Cabinet Left, High-Pressure Laminate Case with Headset

41 ³ / ₄ "	24"	CRTWSAFFL
47 ¹⁵ / ₁₆ "	24"	CRTWSAFFL
54 ¹ / ₈ "	24"	CRTWSAFFL
66 ¹ / ₂ "	24"	CRTWSAFFL

Cabinet Right, Low-Pressure Laminate Case with Headset

41 ³ / ₄ "	24"	CRTWSAFFR
47 ¹⁵ / ₁₆ "	24"	CRTWSAFFR
54 ¹ / ₈ "	24"	CRTWSAFFR
66 ¹ / ₂ "	24"	CRTWSAFFR

Cabinet Right, Low-Pressure Laminate Case with High-Pressure Laminate Headset

41 ³ / ₄ "	24"	CRTWSAFFR
47 ¹⁵ / ₁₆ "	24"	CRTWSAFFR
54 ¹ / ₈ "	24"	CRTWSAFFR
66 ¹ / ₂ "	24"	CRTWSAFFR

Cabinet Right, High-Pressure Laminate Case with Headset

41 ³ / ₄ "	24"	CRTWSAFFR
47 ¹⁵ / ₁₆ "	24"	CRTWSAFFR
54 ¹ / ₈ "	24"	CRTWSAFFR
66 ¹ / ₂ "	24"	CRTWSAFFR

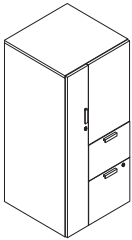

Left-hand unit

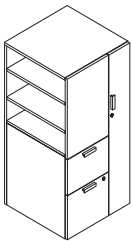

Right-hand unit

Currency Cabinets

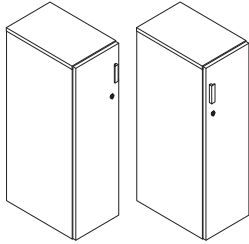

Tip: Cabinets must be attached to adjacent storage, a wall, or in a run of multiple cabinets, to ensure stability and prevent tipping. See Cabinets Stability Guidelines, in the Currency Specification Guide, for details of how many cabinets are required in the run based on cabinet size.

Standard Includes		Required to Specify
<ul style="list-style-type: none"> See <i>Currency Specification Guide</i> for product details. Cabinets: <ul style="list-style-type: none"> – Low-Pressure Laminate case with matching or contrasting Low-Pressure Laminate headset – Low-Pressure Laminate case with High-Pressure Laminate headset, if selected – High-Pressure Laminate case with matching or contrasting High-Pressure Laminate headset, if selected 1" thick top: laminate to match case Lock plug 1 1/4" leveling glides Shipped fully assembled Fixed top shelf on cabinets 66 1/2"H and taller 	<ol style="list-style-type: none"> Style number Size type (see below under Required Selections) Depth (see below under Required Selections) Width (see below under Required Selections) Height (see below under Required Selections) Interior configuration (see below under Required Selections) Low-Pressure Laminate or High-Pressure Laminate color number for case Plastic color number for all edges on laminate case Low-Pressure Laminate or High-Pressure Laminate color number for headset Pulls (see below under Required Selections) Options, if selected (see below) 	
<p>▶ See <i>Surface Materials</i>, page 480.</p>		

Required Selections		Required to Specify
Size Type	• Modular	Specify <i>with modular</i> .
Depth	• 18 7/8"D • 24"D	Specify 18 7/8" depth. Specify 24" depth.
Width	• 12"W	Specify 12" width.
Height	• 41 3/4"H • 47 15/16"H • 54 1/8"H	Specify 41 3/4" height. Specify 47 15/16" height. Specify 54 1/8" height.
Interior Configuration	• Coat hook • Coat rod	Specify <i>with coat hook</i> . Specify <i>with coat rod</i> .

Tip: Coat rods available on 24"D units.

Pull Shape

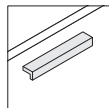

Ledge

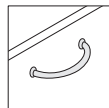

Handle

Options		Required to Specify
Surface Materials	Case	
	<ul style="list-style-type: none"> Low-Pressure Laminate (LPL) price group 1 High-Pressure Laminate (HPL) price group 1 High-Pressure Laminate (HPL) price group 3 	Specify laminate color number. Specify laminate color number. Specify laminate color number.
	Headset	
	<ul style="list-style-type: none"> Low-Pressure Laminate (LPL) price group 1 High-Pressure Laminate (HPL) price group 1 High-Pressure Laminate (HPL) price group 3 	Specify laminate color number. Specify laminate color number. Specify laminate color number.
Shelf	<ul style="list-style-type: none"> No shelf Fixed top shelf 	Specify <i>with no shelf</i> . Specify <i>with fixed top-shelf</i> .
Pulls	<ul style="list-style-type: none"> Handle Ledge 	Specify <i>with handle pull</i> . Specify <i>with ledge pull</i> .
Keys	<ul style="list-style-type: none"> Key plug Master key plug 	Specify <i>with key plug</i> . Specify <i>with master key plug</i> .

Specification Information

Modular Height	Modular Width	Style Number	Modular Depth	
			18 ⁷ / ₈ "	24"

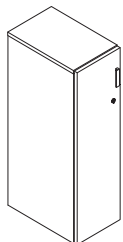

Cabinet—Hinged Left

Low-Pressure Laminate Case with Headset

41 ³ / ₄ "	12"	CRWDL	•	•
47 ¹⁵ / ₁₆ "	12"	CRWDL	•	•
54 ¹ / ₈ "	12"	CRWDL	•	•

Low-Pressure Laminate Case with High-Pressure Laminate Headset

41 ³ / ₄ "	12"	CRWDL	•	•
47 ¹⁵ / ₁₆ "	12"	CRWDL	•	•
54 ¹ / ₈ "	12"	CRWDL	•	•

High-Pressure Laminate Case with Headset

41 ³ / ₄ "	12"	CRWDL	•	•
47 ¹⁵ / ₁₆ "	12"	CRWDL	•	•
54 ¹ / ₈ "	12"	CRWDL	•	•

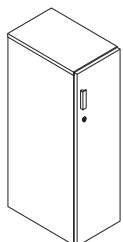

Cabinet—Hinged Right

Low-Pressure Laminate Case with Headset

41 ³ / ₄ "	12"	CRWDR	•	•
47 ¹⁵ / ₁₆ "	12"	CRWDR	•	•
54 ¹ / ₈ "	12"	CRWDR	•	•

Low-Pressure Laminate Case with High-Pressure Laminate Headset

41 ³ / ₄ "	12"	CRWDR	•	•
47 ¹⁵ / ₁₆ "	12"	CRWDR	•	•
54 ¹ / ₈ "	12"	CRWDR	•	•

High-Pressure Laminate Case with Headset

41 ³ / ₄ "	12"	CRWDR	•	•
47 ¹⁵ / ₁₆ "	12"	CRWDR	•	•
54 ¹ / ₈ "	12"	CRWDR	•	•

Migration SE Height-Adjustable Desks

T-Leg

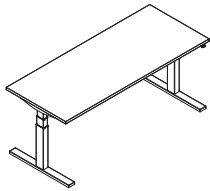

Tip: 76"W Migration SE desks ship standard with a 4" overhang on both sides.

Tip: On extended height desks, any storage higher than 18³/₁₀" will impede height range of desk.

▶ See Height-Adjustable Desk Specification Guide for overhang rules.

Tip: On 23"/24"D and less than 58"W desks, only single and dual flat panel monitor arm applications are permitted for use.

▶ See Steelcase Worktools Specification Guide.

Tip: For desks 29"/30"Dx58"W and greater additional monitor arm configurations are allowed.

▶ See Height-Adjustable Desk Specification Guide for Monitor Arm Guidelines.

Tip: Base supports a maximum distributed weight capacity of 250 pounds. When calculating lifting capacity, subtract the weight of the worksurface.

▶ See Height-Adjustable Desk Specification Guide for worksurface weights.

Standard Includes	Required to Specify
<ul style="list-style-type: none"> ▶ See <i>Height-Adjustable Desk Specification Guide</i> for product details. • Worksurface with square corners: High-Pressure Laminate 1 price group 1 with 3 mm plastic edge • Electric height-adjustable sit-to-stand base: paint • Foot: squared-edge • Square corners • Depth: 23", 24", 29", or 30" • Width: 46", 52", 58", 64", 70", or 76" • Power cord: 9' • ½" adjustable glides • Attachment hardware 	<ol style="list-style-type: none"> Style number Desk type (see below under Required Selections) Overhang and overhang width, if selected (see below under Required Selections) Controller (see below under Required Selections) Desk depth Desk width High-Pressure Laminate color for worksurface Plastic color number for profile edge, if selected Paint color number for base: <ul style="list-style-type: none"> 4799 Platinum Metallic 7207 Black 7241 Arctic White 7360 Merle Options, if selected (see below) <ul style="list-style-type: none"> ▶ See <i>Surface Materials</i>, page 480.

Required Selections	Required to Specify
Desk Type <ul style="list-style-type: none"> • Parametric width desk • Modular width desk 	Specify with <i>parametric desk type</i> . Specify with <i>modular desk type</i> .
Controller <ul style="list-style-type: none"> • Up/down controller • 4 pre-set controller 	Specify with <i>up/down controller</i> . Specify with <i>4 pre-set controller</i> .
Overhang <ul style="list-style-type: none"> • No overhang • Left overhang • Right overhang 	Specify with <i>no overhang</i> . Specify with <i>left overhang</i> . Specify with <i>right overhang</i> .
Overhang width <ul style="list-style-type: none"> • 3"W • 6"W • 9"W • 12"W 	Specify with <i>3"W overhang</i> . Specify with <i>6"W overhang</i> . Specify with <i>9"W overhang</i> . Specify with <i>12"W overhang</i> .

Options	Required to Specify
Surface Materials <ul style="list-style-type: none"> • Laminate price group 3 	Specify laminate color number.
Base <ul style="list-style-type: none"> • Paint price group 1 • Paint price group 2 	Specify paint color number. Specify paint color number.

Specification Information								
Style Number	Depth	Desk Type						
		Modular	46"W	52"W	58"W	64"W	70"W	76"W
		Parametric	46"W	46 ¹ / ₁₆ "W	52 ¹ / ₁₆ "W	58 ¹ / ₁₆ "W	64 ¹ / ₁₆ "W	70 ¹ / ₁₆ "W
				52"W	58"W	64"W	70"W	76"W

High-Pressure Laminate Desks—Extended Height

MGELTRQ	23" or 24"						
		•	•	•	•	•	•
	29" or 30"	•	•	•	•	•	•

Migration SE Height-Adjustable Desks

C-Leg

Migration SE
Height-Adjustable Desks

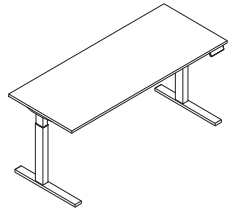

Height-Adjustable Desks

Standard Includes	Required to Specify
<ul style="list-style-type: none"> ▶ See <i>Height-Adjustable Desk Specification Guide</i> for product details. • Worksurface with square corners: High-Pressure Laminate price group 1 with 3 mm plastic edge • Electric height-adjustable sit-to-stand base: paint • Foot: squared-edge • Square corners • Depth: 29" or 30" • Width: 46", 52", 58", 64", 70", or 76" • Power cord: 9' • ½" adjustable glides • Attachment hardware 	<ol style="list-style-type: none"> 1 Style number 2 Desk type (see below under Required Selections) 3 Overhang and overhang width, if selected (see below under Required Selections) 4 Controller (see below under Required Selections) 5 Desk depth 6 Desk width 7 High-Pressure Laminate color for worksurface 8 Plastic color number for profile edge, if selected 9 Paint color number for base: 4799 Platinum Metallic 7207 Black 7241 Arctic White 7360 Merle 10 Options, if selected (see below) ▶ See <i>Surface Materials</i>, page 480.

Tip: 76"W Migration SE desks ship standard with a 4" overhang on both sides.

Tip: On extended height desks, any storage higher than 18 ¾" will impede height range of desk.

▶ See *Height-Adjustable Desk Specification Guide* for overhang rules.

Tip: For desks 29"/30"Dx58"W and greater additional monitor arm configurations are allowed.

▶ See *Height-Adjustable Desk Specification Guide* for monitor arm guidelines.

Tip: Base supports a maximum distributed weight capacity of 250 pounds. When calculating lifting capacity, subtract the weight of the worksurface and understructure.

▶ See *Height-Adjustable Desk Specification Guide* for worksurface weights.

	Required Selections	Required to Specify
Desk Type	<ul style="list-style-type: none"> • Parametric width desk • Modular width desk 	Specify with <i>parametric desk type</i> . Specify with <i>modular desk type</i> .
Controller	<ul style="list-style-type: none"> • Up/down controller • 4 pre-set controller 	Specify with <i>up/down controller</i> . Specify with <i>4 pre-set controller</i> .
Overhang	<ul style="list-style-type: none"> • No overhang • Left overhang • Right overhang <p>Overhang width</p> <ul style="list-style-type: none"> • 3"W • 6"W • 9"W • 12"W 	Specify with <i>no overhang</i> . Specify with <i>left overhang</i> . Specify with <i>right overhang</i> .
Surface Materials	<ul style="list-style-type: none"> • Laminate price group 3 <p>Base</p> <ul style="list-style-type: none"> • Paint price group 1 • Paint price group 2 	Specify laminate color number. Specify paint color number. Specify paint color number.

Specification Information								
Style Number	Depth	Desk Type						
		Modular	46"W	52"W	58"W	64"W	70"W	76"W
Parametric	46"W	46 ½"W	52 ½"W	58 ½"W	64 ½"W	70 ½"W	76 ½"W	76 ½"W
			52"W	58"W	64"W	70"W	76"W	

High-Pressure Laminate Desks—Extended Height

MGELCRQ	29" or 30"	•	•	•	•	•	•
---------	------------	---	---	---	---	---	---

Migration SE Cable and Power Management

Cable Riser

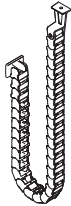

Fence connection



Leg connection

Standard Includes	Required to Specify
-------------------	---------------------

- | | | |
|--|--|--|
| <ul style="list-style-type: none"> ▶ See <i>Height-Adjustable Desk Specification Guide</i> for product details. | <ul style="list-style-type: none"> • Cable riser with fence connection: 7360 Merle paint • Attachment hardware | <ul style="list-style-type: none"> 1 Style number 2 Options, if selected (see below) |
|--|--|--|

Options	Required to Specify
---------	---------------------

- | | |
|--|--|
| Connection <ul style="list-style-type: none"> • Fence • Leg | <ul style="list-style-type: none"> Specify <i>with fence connection</i>. Specify <i>with leg connection</i>. |
|--|--|

Specification Information

• **Style Number**

MIGCR

Cable Brackets

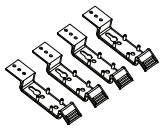

Standard Includes	Required to Specify
-------------------	---------------------

- | | | |
|--|--|--|
| <ul style="list-style-type: none"> ▶ See <i>Height-Adjustable Desk Specification Guide</i> for product details. | <ul style="list-style-type: none"> • Cable brackets, quantity of four: 6527 Merle plastic | <ul style="list-style-type: none"> Style number |
|--|--|--|

Specification Information	
---------------------------	--

• Style Number	• Weight
-----------------------	-----------------

MIGCBK4	0.5 lb
----------------	--------

Ology Height-Adjustable Rectangular Desks

High-Pressure Laminate

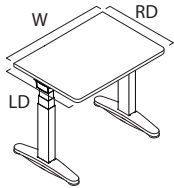

Tip: On extended height desks, any storage higher than 18", or 15½" if the power access door is optioned, will impede lowest height range of worksurface. On basic height desks, any storage higher than 23", or 20½" if the power access door is optioned, will impede lowest height range of worksurface. Do not place storage underneath controller.

Tip: One single monitor is allowed on desks 23"D or deeper and 46"W and wider. ▶ See Height-Adjustable Desk Specification Guide.

Tip: Dual monitors are allowed on 29"D or deeper and 58"W and wider. ▶ See Height-Adjustable Desk Specification Guide.

Tip: Base supports a maximum distributed weight capacity of 360 pounds (2-leg) and 500 pounds (3-leg). When calculating lifting capacity, subtract the weight of the worksurface, understructure, and options selected.

Tip: Antimicrobial additives can be specified only when specifying simple touch controller.

Tip: The standard active touch controller is Bluetooth-enabled to allow pairing with the Steelcase Rise app.

Standard Includes		Required to Specify
▶ See <i>Height-Adjustable Desk Specification Guide</i> for product details.	<ul style="list-style-type: none"> • Worksurface: High-Pressure Laminate price group 1 with 3 mm plastic edge • Electric height-adjustable sit-to-stand base: paint • Active touch controller • Modular widths: 34"–76" • ½" adjustable glides • Power cord: 10¼' • Attachment hardware 	<ol style="list-style-type: none"> 1 Style number 2 Desk depth 3 Desk width 4 High-Pressure Laminate color for worksurface 5 Plastic color number for profile edge on laminate worksurface, if selected 6 Desk corner style (see below under Required Selections) 7 Paint color number for base: 4799 Platinum Metallic 7207 Black 7241 Arctic White 7360 Merle 8 Integrated rail (see below under Required Selections) 9 Antimicrobial or non-antimicrobial components, if simple touch controller selected (see below under Required Selections) 10 Options, if selected (see below) ▶ See <i>Surface Materials</i>, page 480

Required Selections		Required to Specify
Desk Corner Style	<ul style="list-style-type: none"> • Square corners • Radius corners 	Specify <i>with square corners</i> . Specify <i>with radius corners</i> .
Integrated Rail	<ul style="list-style-type: none"> • Without integrated rail • With integrated rail 	Specify <i>without integrated rail</i> . Specify <i>with integrated rail</i> .
Antimicrobial Components	<ul style="list-style-type: none"> • Non-antimicrobial components • Antimicrobial components 	Specify <i>with non-antimicrobial components</i> . Specify <i>with antimicrobial components</i> .

Options		Required to Specify
Surface Materials	High-Pressure Laminate desks <ul style="list-style-type: none"> • Laminate price group 3 Base <ul style="list-style-type: none"> • Paint price group 1 • Paint price group 2 	Specify laminate color number. Specify paint color number. Specify paint color number.
Desk Type	<ul style="list-style-type: none"> • Parametric width desk 	Specify <i>with parametric desk type</i> .
Controller	<ul style="list-style-type: none"> • Simple touch controller 	Specify <i>with simple touch controller</i> .
Grommet	<ul style="list-style-type: none"> • Grommet 	Specify <i>with grommet</i> .

Specification Information

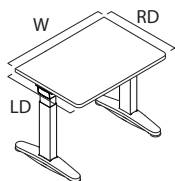

• Style Number	• Depth	• Desk Type								
		Modular	34"W	40"W	46"W	52"W	58"W	64"W	70"W	76"W
•	•	Parametric	34"W	36 ¹ / ₁₆ "W	42 ¹ / ₁₆ "W	48 ¹ / ₁₆ "W	54 ¹ / ₁₆ "W	60 ¹ / ₁₆ "W	66 ¹ / ₁₆ "W	72 ¹ / ₁₆ "W
			36"W	42"W	48"W	54"W	60"W	66"W	72"W	78"W

High-Pressure Laminate Desks — Extended Height

OLELRQ	23" or 24"	•	•	•	•	•	•	•	•
	29" 30"	•	•	•	•	•	•	•	•

High-Pressure Laminate Desks — Basic Height

OLSLRQ	23" or 24"	•	•	•	•	•	•	•	•
	29" or 30"	•	•	•	•	•	•	•	•

Ology Cable and Power Management

Cable Riser

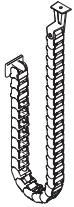

Fence connection



Leg connection

Tip: Cable riser leg connection is not compatible with the Flex height adjustable desk.

Standard Includes	Required to Specify
<ul style="list-style-type: none"> See <i>Height-Adjustable Desk Specification Guide</i> for product details. Cable riser with fence connection: 7360 Merle paint Attachment hardware 	<ul style="list-style-type: none"> 1 Style number 2 Options, if selected (see below)

Options	Required to Specify
Connection <ul style="list-style-type: none"> Fence Leg 	<ul style="list-style-type: none"> Specify <i>with fence connection</i>. Specify <i>with leg connection</i>.

Specification Information

• **Style Number**

OLCR

Cable Basket

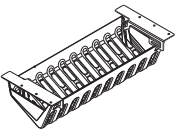

Tip: Cable baskets are compatible with rectangular desks 46 1/8" W or larger.

Tip: Cable basket attaches to the worksurface with brackets, which requires an 8" depth clearance to mount.

Standard Includes	Required to Specify
<ul style="list-style-type: none"> See <i>Height-Adjustable Desk Specification Guide</i> for product details. Cable basket: 6527 Merle plastic 	<ul style="list-style-type: none"> Style number

Specification Information

• **Dimensions** • **Style Number** • **Weight**

D	W	H	Style Number	Weight
8"	18"	4 1/2"	OLCB	1.0 lb

Cable Brackets

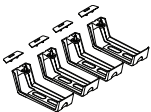

Standard Includes	Required to Specify
<ul style="list-style-type: none"> See <i>Height-Adjustable Desk Specification Guide</i> for product details. Cable brackets, quantity of four: 6527 Merle plastic 	<ul style="list-style-type: none"> Style number

Specification Information

• **Dimensions** • **Style Number** • **Weight**

D	H	Style Number	Weight
6"	2"	OLCBK4	0.5 lb

Groupwork Table Tops

Rectangular

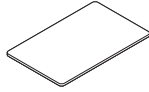

Tip: Standard worksurfaces are 1 1/8" thick. However, the actual thickness between Low-Pressure Laminate (LPL) and High-Pressure Laminate (HPL) worksurfaces is slightly different. It is recommended that only worksurfaces of the same type are specified in a given application. In addition, there may be sheen or texture differences when using LPL and HPL in adjacent applications. Please use caution when mixing and matching different worksurface types.

Tip: Reinforcing channel (TSATRC39, TSATRC48, TSATRC57, or TSATRC72), ordered separately, must be used with tops 60"W and larger. ▶ See Conference and Collaborative Tables Specification Guide.

Tip: To ensure proper leg usage, consult the Groupwork table top, leg, and base combination section of the specification guide. ▶ See Conference and Collaborative Tables Specification Guide.

Standard Includes	Required to Specify
<ul style="list-style-type: none"> ▶ See <i>Conference and Collaborative Tables Specification Guide</i> • 1 1/8"-thick top: Low-Pressure Laminate or High-Pressure Laminate price group 1 • 3 mm radius profile edge: plastic for product details. 	<ol style="list-style-type: none"> 1 Style number 2 Low-Pressure Laminate or High-Pressure Laminate color number for top, as appropriate 3 Plastic edge band color number for top 4 Options, if selected (see below) <ul style="list-style-type: none"> ▶ See <i>Surface Materials</i>, page 480.

Options	Required to Specify
Surface Materials <ul style="list-style-type: none"> • High-Pressure Laminate worksurfaces • Laminate price group 3 	Specify laminate color number.

Specification Information			
Dimensions	D	W	Style
			Number
			LPL
			HPL

Rectangular Tops			
Dimensions	D	W	Style Number
18" x 48"	18"	48"	TS4TLR1848
18" x 60"	18"	60"	TS4TLR1860
18" x 66"	18"	66"	TS4TLR1866
18" x 72"	18"	72"	TS4TLR1872
18" x 84"	18"	84"	TS4TLR1884
24" x 36"	24"	36"	TS4TLR2436
24" x 42"	24"	42"	TS4TLR2442
24" x 48"	24"	48"	TS4TLR2448
24" x 60"	24"	60"	TS4TLR2460
24" x 66"	24"	66"	TS4TLR2466
24" x 72"	24"	72"	TS4TLR2472
24" x 84"	24"	84"	TS4TLR2484
30" x 36"	30"	36"	TS4TLR3036
30" x 42"	30"	42"	TS4TLR3042
30" x 48"	30"	48"	TS4TLR3048
30" x 60"	30"	60"	TS4TLR3060
30" x 66"	30"	66"	TS4TLR3066
30" x 72"	30"	72"	TS4TLR3072

Groupwork Table Tops

Round and Square

Tip: Standard worksurfaces are 1 1/8" thick. However, the actual thickness between Low-Pressure Laminate (LPL) and High-Pressure Laminate (HPL) worksurfaces is slightly different. It is recommended that only worksurfaces of the same type are specified in a given application. In addition, there may be sheen or texture differences when using LPL and HPL in adjacent applications. Please use caution when mixing and matching different worksurface types.

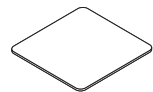

Standard Includes		Required to Specify
<ul style="list-style-type: none"> See <i>Conference and Collaborative Tables Specification Guide</i> for product details. 	<ul style="list-style-type: none"> Top: 1 1/8"-thick: Low-Pressure Laminate or High-Pressure Laminate price group 1, if selected Top: 1 3/8"-thick (Suffix T): Low-Pressure Laminate or High-Pressure Laminate, if selected 3 mm radius profile edge: plastic 	<ol style="list-style-type: none"> Style number Low-Pressure Laminate or High-Pressure Laminate color number for top, as appropriate Plastic edge band color number for top Options, if selected (see below) <p>▶ See <i>Surface Materials</i>, page 480.</p>

Options		Required to Specify
Surface Materials	High-Pressure Laminate worksurfaces <ul style="list-style-type: none"> Laminate price group 3 	Specify laminate color number.

Specification Information			
Dimensions		Style Number	Style Number
D	W	LPL	HPL
:	:	:	:

Round Tops

1 1/8"-thick top

24"	24"	TS4TLDR24	TS4THDR24
30"	30"	TS4TLDR30	TS4THDR30
36"	36"	TS4TLDR36	TS4THDR36
42"	42"	TS4TLDR42	TS4THDR42
48"	48"	TS4TLDR48	TS4THDR48
:	:	:	:

Square Tops

1 1/8"-thick top

24"	24"	TS4TLR2424	TS4THR2424
30"	30"	TS4TLR3030	TS4THR3030
36"	36"	TS4TLR3636	TS4THR3636
42"	42"	TS4TLR4242	TS4THR4242
48"	48"	TS4TLR4848	TS4THR4848
:	:	:	:

Tip: Attachment hardware is to be used with Currency, Kick, or Groupwork table tops only.

Standard Includes	Required to Specify
<ul style="list-style-type: none"> ▶ See <i>Conference and Collaborative Tables Specification Guide</i> for product details. • Base: paint price group 1 • Glides: black plastic only • Attachment hardware 	<ul style="list-style-type: none"> 1 Style number 2 Paint color number for base 3 Options, if selected (see below) ▶ See <i>Surface Materials</i>, page 480.

Options	Required to Specify
Surface Materials <ul style="list-style-type: none"> • Paint price group 1 • Paint price group 2 	<ul style="list-style-type: none"> Specify paint color number. Specify paint color number.

Specification Information

Dimensions			Style
Height	Diameter of Base	Diameter of Column	Number

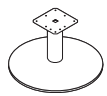

Coffee-Height Round Table Base

16 1/8"	22"	3"	TS4TCOF22
:	:	:	:

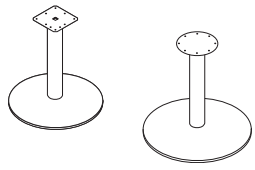

Round Table Bases

27 3/8"	22"	3"	TS4TBASE22
27 3/8"	28"	3"	TS4TBASE28
27 3/8"	28"	5"	TS4TBASE285
:	:	:	:

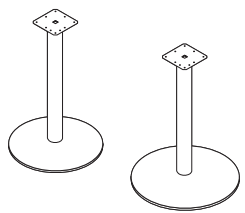

Café-Height Round Table Bases

41"	22"	3"	TS4TCAFE22
41"	28"	3"	TS4TCAFE28
41"	28"	5"	TS4TCAFE285
:	:	:	:

Tip: For heavy use applications, it is recommended to use the 28" diameter base with 5" diameter column for added rigidity.

Conference and Collaborative Tables

Groupwork Table Legs

Tip: Levelers are adjustable (lower height), but do not slide. To easily move tables, order tables with casters.

Tip: Attachment hardware is to be used with Currency, Kick, or Groupwork table tops only.

Tip: To ensure proper stability when casters are specified, see the Groupwork table top, leg, and base combinations section of the specifications guide.

Tip: Attaching monitor arms to freestanding tables with casters or glides is not recommended due to tipping hazards.

Tip: Translucent screens and slatwalls are not available on 18"D fixed tops, if post legs are selected.

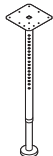
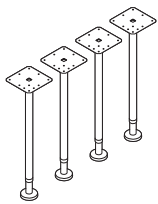
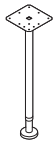

Tip: Translucent screens and slatwalls are not available on 18"D or 24"D height-adjustable tops, if standing-height adjustable post legs are selected.

Tip: Standing-height adjustable post leg is not available with 18"D tops.

Standard Includes	Required to Specify
<ul style="list-style-type: none"> ▶ See <i>Conference and Collaborative Tables Specification Guide</i> for product details. 	<ul style="list-style-type: none"> Table leg(s): paint price group 1 Levelers on post and standing-height leg(s): black plastic only Pin height adjustable leg(s) on standing-height only Attachment hardware
	<ul style="list-style-type: none"> 1 Style number 2 Paint color number for leg(s) 3 Options, if selected (see below) ▶ See <i>Surface Materials</i>, page 480.

Options	Required to Specify
Surface Materials <ul style="list-style-type: none"> Paint price group 1 Paint price group 2 	<ul style="list-style-type: none"> Specify paint color number. Specify paint color number.
Casters <ul style="list-style-type: none"> One locking caster 	<ul style="list-style-type: none"> Specify <i>with caster</i>.
<ul style="list-style-type: none"> Four casters (two locking and two non-locking) 	<ul style="list-style-type: none"> Specify <i>with four casters</i>.

Specification Information	
• Height	• Style Number
•	•
•	•
•	•
•	•
•	•
•	•
•	•
•	•
•	•

One Post Leg	
27 ³ / ₈ "	TS4L27PG
•	•
•	•
•	•

Package of Four Post Legs	
27 ³ / ₈ "	TS4L27PG4
•	•
•	•
•	•

One Standing-Height Adjustable Post Leg	
27 ³ / ₈ "–43 ⁷ / ₈ "	TS4LSHPG
•	•
•	•

▶ **Specification Information, continued on next page**

► **Specification Information, continued from previous page**

Specification Information

Tip: Translucent screens and slatwalls are not available on 18"D fixed tops, if post legs are selected.

• Height	• Style
.....	• Number
.....
.....

Package of Four Standing-Height Adjustable Post Legs

27 ³ / ₈ "–43 ⁷ / ₈ "	TS4LSHPG4
.....

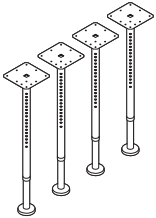

Groupwork Wire Management Trough

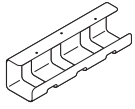

Standard Includes	Required to Specify
<p>▶ See <i>Conference and Collaborative Tables Specification Guide</i> for product details.</p> <p>• Wire management trough: paint</p>	<p>1 Style number 2 Paint color number for wire management trough</p> <p>▶ See <i>Surface Materials</i>, page 480.</p>

Specification Information

• **Style**
• **Number**

TS4WIRE

Groupwork Screens

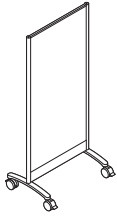

Tip: Screens must be specified with fabric on both sides, e³ CeramicSteel on both sides, or laminate on both sides. For Canada, screens are available in fabric or e³ CeramicSteel on both sides only.

Tip: See CeramicSteel Cleaning/Daily Care and Maintenance for additional information.

▶ See Collaborative Surfaces Specification Guide.

Tip: 54"H screens are available in vertical or horizontal fabric direction. 66"H screens are available in vertical fabric direction only.

Tip: e³ CeramicSteel writing surface is magnetic.

Tip: Three-leg base is used when two or more screens are placed next to each other on angles. Four-leg bases can be used next to each other only in a straight configuration.

Tip: 66"H screens are not available with the three-leg base option.

Tip: Levelers have 1/4" adjustment (higher only) and do not slide. If frequent movement is needed, order screen with casters.

Tip: Flip-chart pegs, located 17⁵/₈" apart, are located on only one side of the top cap.

Standard Includes	Required to Specify
<ul style="list-style-type: none"> ▶ See <i>Conference and Collaborative Tables Specification Guide</i> for product details. Tackboard, both sides if selected: price group A Horizontal or vertical fabric direction, if 54"H screens is selected Vertical fabric direction, if 66"H screen is selected e³ CeramicSteel writing surface, both sides, if selected: 7655 e³ CeramicSteel White High Gloss Laminate markerboard, both sides, if selected: 2977 White Markerboard Laminate Frame, top cap, uprights, bottom channel, and four-leg base: paint price group 1 Four-leg base with four locking casters: black plastic Attachment hardware Shipped ready to assemble 	<ol style="list-style-type: none"> Style number Fabric color number, 7655 e³ CeramicSteel White High Gloss, or 2977 White Markerboard Laminate for side 1 Fabric color number, 7655 e³ CeramicSteel White High Gloss, or 2977 White Markerboard Laminate for side 2 Fabric direction for 54"H screen, if selected Paint color number for frame Options, if selected (see below) <p>▶ See <i>Surface Materials</i>, page 480.</p>

Options	Required to Specify
<p>Surface Materials</p> <ul style="list-style-type: none"> Fabric surface on tackboard <ul style="list-style-type: none"> Price group A Fabric price group 1 Fabric price group 2 Fabric price group 3 Fabric direction <ul style="list-style-type: none"> Horizontal application Vertical application e³ CeramicSteel writing surface <ul style="list-style-type: none"> e³ CeramicSteel surface on both sides Laminate markerboard <ul style="list-style-type: none"> 2977 White Markerboard Laminate Frame and base <ul style="list-style-type: none"> Paint price group 1 Paint price group 2 	<ul style="list-style-type: none"> Specify fabric color number. Specify fabric color number. Specify fabric color number. Specify fabric color number. Specify with <i>horizontal application</i>. Specify with <i>vertical application</i>. Specify with <i>7655 White High Gloss</i>. Specify with <i>2977 White Markerboard Laminate</i>. Specify paint color number. Specify paint color number. Specify with <i>three-leg base</i>. Specify with <i>levelers</i>. Specify with <i>flip-chart pegs</i>.
<p>Base</p> <ul style="list-style-type: none"> Three-leg base with three black plastic locking casters 	<ul style="list-style-type: none"> Specify with <i>three-leg base</i>.
<p>Levelers</p> <ul style="list-style-type: none"> Levelers (three or four) 	<ul style="list-style-type: none"> Specify with <i>levelers</i>.
<p>Flip-Chart Pegs</p> <ul style="list-style-type: none"> Top cap with flip-chart pegs on one side 	<ul style="list-style-type: none"> Specify with <i>flip-chart pegs</i>.

Specification Information

Dimensions			Style
D	W	H	Number

54"H Screens

16"	24"	54"	TS4S2454
16"	30"	54"	TS4S3054
16"	36"	54"	TS4S3654
16"	42"	54"	TS4S4254
16"	48"	54"	TS4S4854

66"H Screens

16"	24"	66"	TS4S2466
16"	30"	66"	TS4S3066
16"	36"	66"	TS4S3666
16"	42"	66"	TS4S4266
16"	48"	66"	TS4S4866

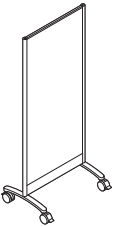
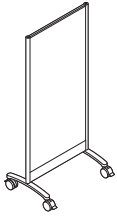

Conference and Collaborative Tables

Groupwork Marker Trays

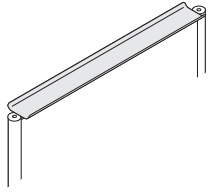

Tip: Attachment hardware is included with screen. Tray is affixed to the top cap.

Standard Includes	Required to Specify
-------------------	---------------------

- | | |
|---|--|
| ▶ See <i>Conference and Collaborative Tables Specification Guide</i> for product details. | ▶ Marker tray: paint price group 1 |
| | ▶ 1 Style number |
| | ▶ 2 Paint color number for marker tray |
| | ▶ 3 Options, if selected (see below) |
| | ▶ See <i>Surface Materials</i> , page 480. |

Options	Required to Specify
---------	---------------------

- | | |
|------------------|-----------------------------|
| Surface | • Paint price group 1 |
| Materials | • Paint price group 2 |
| | Specify paint color number. |
| | Specify paint color number. |

Specification Information			
• Dimensions			• Style
D	W	H	Number

2 1/2"	24"	1/2"	TS4SR24
2 1/2"	30"	1/2"	TS4SR30
2 1/2"	36"	1/2"	TS4SR36
2 1/2"	42"	1/2"	TS4SR42
2 1/2"	48"	1/2"	TS4SR48
:	:	:	:

Simple Personal Tables

25¹/₂"H

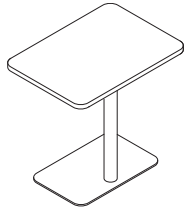

Tip: Column is offset to allow table to be moved closer to chair.

Standard Includes	Required to Specify
<ul style="list-style-type: none"> See <i>Conference and Collaborative Tables Specification Guide</i> for product details. 1 1/8" thick table top: Low-Pressure Laminate (LPL) Edge band: default color to match laminate Base and column: paint price group 1 	<ol style="list-style-type: none"> Style number Worksurface size type (see below under Required Selections) Depth (see below under Required Selections) Width (see below under Required Selections) Low-Pressure Laminate color number for table top Paint color number for base and column Options, if selected (see below) <p>▶ See <i>Surface Materials</i>, page 480.</p>

Required Selections		Required to Specify
Depth	Modular <ul style="list-style-type: none"> 16"D 18"D 	Specify depth. Specify depth.
Width	Modular <ul style="list-style-type: none"> 24"W 26"W 28"W 	Specify width. Specify width. Specify width.

Options		Required to Specify
Surface Materials	High-Pressure Laminate top <ul style="list-style-type: none"> High-Pressure Laminate price group 1 High-Pressure Laminate price group 3 	Specify High-Pressure Laminate color number. Specify High-Pressure Laminate color number.
	Base and column <ul style="list-style-type: none"> Paint price group 1 Paint price group 2 	Specify paint color number. Specify paint color number.

Specification Information					
Style Number	Dimensions Modular Depth	Modular Width	24"W	26"W	28"W
Low-Pressure Laminate					
TS4WPERLNGE	16"		•	•	•
	18"		•	•	•
High-Pressure Laminate Price Group 1					
TS4WPERLNGE	16"		•	•	•
	18"		•	•	•
High-Pressure Laminate Price Group 3					
TS4WPERLNGE	16"		•	•	•
	18"		•	•	•

Conference and Collaborative Tables

Simple Lounge-Height Round

25½"H

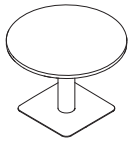

Standard Includes	Required to Specify
<ul style="list-style-type: none"> ▶ See <i>Conference and Collaborative Tables Specification Guide</i> for product details. • 1½" thick table top: Low-Pressure Laminate (LPL) • Edge band: default color to match laminate • Base and column: paint price group 1 	<ol style="list-style-type: none"> 1 Style number 2 Worksurface size type (see below under Required Selections) 3 Diameter (see below under Required Selections) 4 Low-Pressure Laminate color number for table top 5 Paint color number for base and column 6 Options, if selected (see below) <ul style="list-style-type: none"> ▶ See <i>Surface Materials</i>, page 480.

Tip: Tops under 31" Dia. get a 3" column. Tops 31" Dia. and larger get a 5" column.

Required Selections		Required to Specify
Size Type	• Modular	Specify modular.
Diameter	Modular <ul style="list-style-type: none"> • 30" Dia. • 36" Dia. • 42" Dia. • 48" Dia. 	Specify diameter. Specify diameter. Specify diameter. Specify diameter.

Options		Required to Specify
Surface Materials	High-Pressure Laminate top <ul style="list-style-type: none"> • High-Pressure Laminate price group 1 • High-Pressure Laminate price group 3 	Specify High-Pressure Laminate color number. Specify High-Pressure Laminate color number.
	Base and column <ul style="list-style-type: none"> • Paint price group 1 • Paint price group 2 	Specify paint color number. Specify paint color number.

Specification Information

Style Number	Modular Diameter

Low-Pressure Laminate

TS4WRDLNGE	30"
	36"
	42"
	48"

High-Pressure Laminate Price Group 1

TS4WRDLNGE	30"
	36"
	42"
	48"

High-Pressure Laminate Price Group 3

TS4WRDLNGE	30"
	36"
	42"
	48"

Simple Lounge-Height Square Tables

25½"H

Simple Lounge-Height
Square Tables

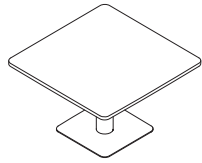

Tip: Tops 30"W get a 3" column. Tops 36"W and larger get a 5" column.

Standard Includes	Required to Specify
<ul style="list-style-type: none"> ▶ See <i>Conference and Collaborative Tables Specification Guide</i> for product details. 1 ½" thick table top: Low-Pressure Laminate (LPL) Edge band: default color to match laminate Base and column: paint price group 1 	<ol style="list-style-type: none"> Style number Worksurface size type (see below under Required Selections) Width (see below under Required Selections) Low-Pressure Laminate color number for table top Paint color number for base and column Options, if selected (see below) <p>▶ See <i>Surface Materials</i>, page 480.</p>

Required Selections	Required to Specify
<p>Width</p> <p>Modular</p> <ul style="list-style-type: none"> 30"W 36"W 42"W 48"W 	<p>Specify width.</p> <p>Specify width.</p> <p>Specify width.</p> <p>Specify width.</p>

Options	Required to Specify
<p>Surface Materials</p> <p>High-Pressure Laminate top</p> <ul style="list-style-type: none"> High-Pressure Laminate price group 1 High-Pressure Laminate price group 3 	<p>Specify High-Pressure Laminate color number.</p> <p>Specify High-Pressure Laminate color number.</p>
<p>Base and column</p> <ul style="list-style-type: none"> Paint price group 1 Paint price group 2 	<p>Specify paint color number.</p> <p>Specify paint color number.</p>

Specification Information	
<p>Style Number</p> <p>.....</p>	<p>Dimensions</p> <p>Modular</p> <p>Width</p> <p>.....</p>

Low-Pressure Laminate	
TS4WSQLNGE	30"
	36"
	42"
	48"

High-Pressure Laminate Price Group 1	
TS4WSQLNGE	30"
	36"
	42"
	48"

High-Pressure Laminate Price Group 3	
TS4WSQLNGE	30"
	36"
	42"
	48"

Conference and Collaborative Tables

Simple Lounge-Height Rectangle Tables

25¹/₂"H

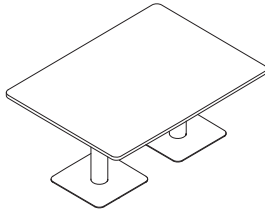

Tip: Tops 30"W get a 3" column. Tops 36"W and larger get a 5" column. Tops 60"W and over get two 5" columns.

Standard Includes	Required to Specify
<ul style="list-style-type: none"> ▶ See <i>Conference and Collaborative Tables Specification Guide</i> for product details. • 1¹/₈" thick table top: Low-Pressure Laminate (LPL) • Edge band: default color to match laminate • Base and column: paint price group 1 	<ol style="list-style-type: none"> 1 Style number 2 Worksurface size type (see below under Required Selections) 3 Depth (see below under Required Selections) 4 Width (see below under Required Selections) 5 Low-Pressure Laminate color number for table top 6 Paint color number for base and column 7 Options, if selected (see below) <p>▶ See <i>Surface Materials</i>, page 480.</p>

Required Selections		Required to Specify
Depth	Modular <ul style="list-style-type: none"> • 22"D • 24"D • 30"D • 36"D • 42"D 	Specify depth. Specify depth. Specify depth. Specify depth. Specify depth.
Width	Modular <ul style="list-style-type: none"> • 30"W • 36"W • 42"W • 48"W • 54"W • 60"W • 66"W • 72"W 	Specify width. Specify width. Specify width. Specify width. Specify width. Specify width. Specify width. Specify width.

Options		Required to Specify
Surface Materials	High-Pressure Laminate top <ul style="list-style-type: none"> • High-Pressure Laminate price group 1 • High-Pressure Laminate price group 3 	Specify High-Pressure Laminate color number. Specify High-Pressure Laminate color number.
	Base and column <ul style="list-style-type: none"> • Paint price group 1 • Paint price group 2 	Specify paint color number. Specify paint color number.

Specification Information

Style Number	Dimensions Modular Depth	Modular Width	30"W	36"W	42"W	48"W	54"W	60"W	66"W	72"W

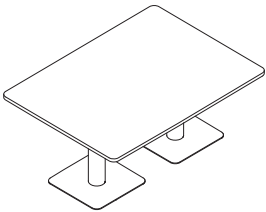

Low-Pressure Laminate

TS4WRECLNGE	22"		•	•	•	•	•	•	•	•
<i>Tip: For modular rectangle sizes, width must be greater than depth. Please refer to TS4WSQLNGE for modular square size selections.</i>	24"		•	•	•	•	•	•	•	•
	30"		•	•	•	•	•	•	•	•
	36"		N.A.	•	•	•	•	•	•	•
	42"		N.A.	N.A.	•	•	•	•	•	•
	:	:	:	:	:	:	:	:	:	:

High-Pressure Laminate Price Group 1

TS4WRECLNGE	22"		•	•	•	•	•	•	•	•
	24"		•	•	•	•	•	•	•	•
	30"		•	•	•	•	•	•	•	•
	36"		N.A.	•	•	•	•	•	•	•
	42"		N.A.	N.A.	•	•	•	•	•	•
:	:	:	:	:	:	:	:	:	:	:

High-Pressure Laminate Price Group 3

TS4WRECLNGE	22"		•	•	•	•	•	•	•	•
	24"		•	•	•	•	•	•	•	•
	30"		•	•	•	•	•	•	•	•
	36"		N.A.	•	•	•	•	•	•	•
	42"		N.A.	N.A.	•	•	•	•	•	•
:	:	:	:	:	:	:	:	:	:	:

Simple Lounge-Height Soft Square Tables

25¹/₂"H

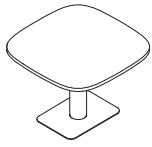

Standard Includes	Required to Specify
<ul style="list-style-type: none"> ▶ See <i>Conference and Collaborative Tables Specification Guide</i> for product details. • 1 1/8" thick table top: Low-Pressure Laminate (LPL) • Edge band: default color to match laminate • Base and column: paint price group 1 	<ol style="list-style-type: none"> 1 Style number 2 Worksurface size type (see below under Required Selections) 3 Width (see below under Required Selections) 4 Low-Pressure Laminate color number for table top 5 Paint color number for base and column 6 Options, if selected (see below) <p>▶ See <i>Surface Materials</i>, page 480.</p>

Tip: Tops 36"W and over get a 5" column. Tops 60"W get two 5" columns.

Required Selections		Required to Specify
Width	<p>Modular</p> <ul style="list-style-type: none"> • 36"W • 42"W • 48"W • 54"W • 60"W 	<p>Specify width.</p> <p>Specify width.</p> <p>Specify width.</p> <p>Specify width.</p> <p>Specify width.</p>

Options		Required to Specify
Surface Materials	<p>High-Pressure Laminate top</p> <ul style="list-style-type: none"> • High-Pressure Laminate price group 1 • High-Pressure Laminate price group 3 <hr/> <p>Base and column</p> <ul style="list-style-type: none"> • Paint price group 1 • Paint price group 2 	<p>Specify High-Pressure Laminate color number.</p> <p>Specify High-Pressure Laminate color number.</p> <hr/> <p>Specify paint color number.</p> <p>Specify paint color number.</p>

Specification Information

• Style Number	• Dimensions Modular Width
----------------	----------------------------

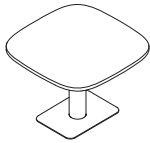

Low-Pressure Laminate

TS4WSFTSQLNGE	36"
	42"
	48"
	54"
	60"

High-Pressure Laminate Price Group 1

TS4WSFTSQLNGE	36"
	42"
	48"
	54"
	60"

High-Pressure Laminate Price Group 3

TS4WSFTSQLNGE	36"
	42"
	48"
	54"
	60"

Conference and Collaborative Tables

Simple Lounge-Height Soft Rectangle Tables

25¹/₂"H

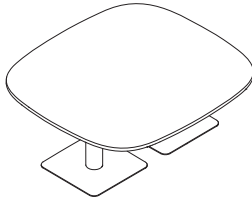

Standard Includes	Required to Specify
<ul style="list-style-type: none"> ▶ See <i>Conference and Collaborative Tables Specification Guide</i> for product details. 1 1/8" thick table top: Low-Pressure Laminate (LPL) Edge band: default color to match laminate Base and column: paint price group 1 	<ol style="list-style-type: none"> Style number Worksurface size type (see below under Required Selections) Depth (see below under Required Selections) Width (see below under Required Selections) Low-Pressure Laminate color number for table top Paint color number for base and column Options, if selected (see below) <p>▶ See <i>Surface Materials</i>, page 480.</p>

Tip: Tops 36"W and over get a 5" column. Tops 60"W get two 5" columns.

	Required Selections	Required to Specify
Depth	Modular <ul style="list-style-type: none"> 36"D 42"D 48"D 54"D 60"D 	Specify depth. Specify depth. Specify depth. Specify depth. Specify depth.
Width	Modular <ul style="list-style-type: none"> 36"W 42"W 48"W 54"W 60"W 66"W 72"W 	Specify width. Specify width. Specify width. Specify width. Specify width. Specify width. Specify width.

	Options	Required to Specify
Surface Materials	High-Pressure Laminate top <ul style="list-style-type: none"> High-Pressure Laminate price group 1 High-Pressure Laminate price group 3 	Specify High-Pressure Laminate color number. Specify High-Pressure Laminate color number.
	Base and column <ul style="list-style-type: none"> Paint price group 1 Paint price group 2 	Specify paint color number. Specify paint color number.

Specification Information

Style Number	Dimensions Modular Depth	Modular Width	36"W	42"W	48"W	54"W	60"W	66"W	72"W

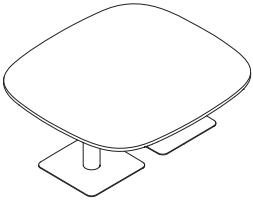

Low-Pressure Laminate

TS4WSFTRECLNGE	36"	42"	48"	54"	60"	66"	72"
36"	•	•	•	•	•	•	•
42"	N.A.	•	•	•	•	•	•
48"	N.A.	N.A.	•	•	•	•	•
54"	N.A.	N.A.	N.A.	•	•	•	•
60"	N.A.	N.A.	N.A.	N.A.	•	•	•

Tip: For modular rectangle sizes, width must be greater than depth. Please refer to TS4WSFTSQLNGE for modular square size selections.

High-Pressure Laminate Price Group 1

TS4WSFTRECLNGE	36"	42"	48"	54"	60"	66"	72"
36"	•	•	•	•	•	•	•
42"	N.A.	•	•	•	•	•	•
48"	N.A.	N.A.	•	•	•	•	•
54"	N.A.	N.A.	N.A.	•	•	•	•
60"	N.A.	N.A.	N.A.	N.A.	•	•	•

High-Pressure Laminate Price Group 3

TS4WSFTRECLNGE	36"	42"	48"	54"	60"	66"	72"
36"	•	•	•	•	•	•	•
42"	N.A.	•	•	•	•	•	•
48"	N.A.	N.A.	•	•	•	•	•
54"	N.A.	N.A.	N.A.	•	•	•	•
60"	N.A.	N.A.	N.A.	N.A.	•	•	•

Simple Working-Height Round Tables

28¹/₂"H



Standard Includes	Required to Specify
<ul style="list-style-type: none"> ▶ See <i>Conference and Collaborative Tables Specification Guide</i> for product details. • 1 1/8" thick table top: Low-Pressure Laminate (LPL) • Edge band: default color to match laminate • Post legs: paint price group 1 • Glides, if post legs are selected 	<ol style="list-style-type: none"> 1 Style number 2 Worksurface size type (see below under Required Selections) 3 Diameter (see below under Required Selections) 4 Low-Pressure Laminate color number for table top 5 Paint color number for post legs 6 Options, if selected (see below) <p>▶ See <i>Surface Materials</i>, page 480.</p>

Required Selections	Required to Specify
<p>Diameter</p> <p>Modular</p> <ul style="list-style-type: none"> • 30" Dia. • 36" Dia. • 42" Dia. • 48" Dia. 	<p>Specify diameter.</p> <p>Specify diameter.</p> <p>Specify diameter.</p> <p>Specify diameter.</p>

Options	Required to Specify
<p>Surface Materials</p> <p>High-Pressure Laminate top</p> <ul style="list-style-type: none"> • High-Pressure Laminate price group 1 • High-Pressure Laminate price group 3 <hr/> <p>Base</p> <ul style="list-style-type: none"> • Paint price group 1 • Paint price group 2 	<p>Specify High-Pressure Laminate color number.</p> <p>Specify High-Pressure Laminate color number.</p> <hr/> <p>Specify paint color number.</p> <p>Specify paint color number.</p>

<p>Column Base</p> <ul style="list-style-type: none"> • 30" Dia. tops • 36" Dia. tops • 42" Dia.–48" Dia. tops 	<p>Specify <i>with column</i>.</p> <p>Specify <i>with column</i>.</p> <p>Specify <i>with column</i>.</p>
--	--

<p>Casters for Post Legs</p> <ul style="list-style-type: none"> • Four casters (two locking and two non-locking) 	<p>Specify <i>with casters</i>.</p>
--	-------------------------------------

Tip: Tops 30" Dia. get a 3" column. Tops 36" Dia. and larger get a 5" column.

Tip: Glides on post legs are 1 1/2" long and provide 1" of leveling.



Specification Information

• Style Number	• Dimensions Modular Diameter
----------------	-------------------------------

Low-Pressure Laminate

TS4WRD	30"
	36"
	42"
	48"

High-Pressure Laminate Price Group 1

TS4WRD	30"
	36"
	42"
	48"

High-Pressure Laminate Price Group 3

TS4WRD	30"
	36"
	42"
	48"

Simple Working-Height Square Tables

28¹/₂"H

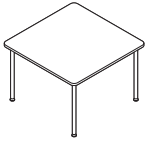

Standard Includes	Required to Specify
<ul style="list-style-type: none"> ▶ See <i>Conference and Collaborative Tables Specification Guide</i> for product details. • 1 1/8" thick table top: Low-Pressure Laminate (LPL) • Edge band: default color to match laminate • Post legs: paint price group 1 • Glides, if post legs are selected 	<ol style="list-style-type: none"> 1 Style number 2 Worksurface size type (see below under Required Selections) 3 Width (see below under Required Selections) 4 Low-Pressure Laminate color number for table top 5 Paint color number for post legs 6 Options, if selected (see below) <p>▶ See <i>Surface Materials</i>, page 480.</p>

Required Selections	Required to Specify
<p>Width</p> <p>Modular</p> <ul style="list-style-type: none"> • 30"W • 36"W • 42"W • 48"W 	<p>Specify width.</p> <p>Specify width.</p> <p>Specify width.</p> <p>Specify width.</p>

Options	Required to Specify
<p>Surface Materials</p> <p>High-Pressure Laminate top</p> <ul style="list-style-type: none"> • High-Pressure Laminate price group 1 • High-Pressure Laminate price group 3 <hr/> <p>Base</p> <ul style="list-style-type: none"> • Paint price group 1 • Paint price group 2 	<p>Specify High-Pressure Laminate color number.</p> <p>Specify High-Pressure Laminate color number.</p> <hr/> <p>Specify paint color number.</p> <p>Specify paint color number.</p>

<p>Column Base</p> <ul style="list-style-type: none"> • 30"W tops • 36"W tops • 42"W–48"W tops 	<p>Specify <i>with column</i>.</p> <p>Specify <i>with column</i>.</p> <p>Specify <i>with column</i>.</p>
--	--

<p>Casters for Post Legs</p> <ul style="list-style-type: none"> • Four casters (two locking and two non-locking) 	<p>Specify <i>with casters</i>.</p>
--	-------------------------------------

Tip: Tops 30" Dia. get a 3" column. Tops 36" Dia. and larger get a 5" column.

Tip: Glides on post legs are 1 1/2" long and provide 1" of leveling.

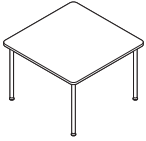

Specification Information

Style Number	Dimensions Modular Width
--------------	--------------------------

Low-Pressure Laminate

TS4WSQ	30"
	36"
	42"
	48"

High-Pressure Laminate Price Group 1

TS4WSQ	30"
	36"
	42"
	48"

High-Pressure Laminate Price Group 3

TS4WSQ	30"
	36"
	42"
	48"

Simple Working-Height Rectangle Tables

28¹/₂"H

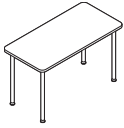

Tip: Reinforcing channel (TSATRC57), ordered separately, must be used on tables with post legs that have 60" or more of unsupported knee space.

Tip: Tops 30"W get a 3" column. Tops 36"W and over get a 5" column. Tops 60"W and over get two 5" columns.

Tip: Glides on post legs are 1¹/₂" long and provide 1" of leveling.

Standard Includes	Required to Specify
<ul style="list-style-type: none"> ▶ See <i>Conference and Collaborative Tables Specification Guide</i> for product details. • 1¹/₈" thick table top: Low-Pressure Laminate (LPL) • Edge band: default color to match laminate • Post legs: paint price group 1 • Glides, if post legs are selected 	<ol style="list-style-type: none"> 1 Style number 2 Worksurface size type (see below under Required Selections) 3 Depth (see below under Required Selections) 4 Width (see below under Required Selections) 5 Low-Pressure Laminate color number for table top 6 Paint color number for post legs 7 Options, if selected (see below) <p>▶ See <i>Surface Materials</i>, page 480.</p>

Required Selections	Required to Specify
<p>Depth</p> <p>Modular</p> <ul style="list-style-type: none"> • 24"D • 30"D • 36"D • 42"D 	<p>Specify depth.</p> <p>Specify depth.</p> <p>Specify depth.</p> <p>Specify depth.</p>
<p>Width</p> <p>Modular</p> <ul style="list-style-type: none"> • 30"W • 36"W • 42"W • 48"W • 54"W • 60"W • 66"W • 72"W 	<p>Specify width.</p> <p>Specify width.</p> <p>Specify width.</p> <p>Specify width.</p> <p>Specify width.</p> <p>Specify width.</p> <p>Specify width.</p> <p>Specify width.</p>

Options	Required to Specify
<p>Surface Materials</p> <p>High-Pressure Laminate top</p> <ul style="list-style-type: none"> • High-Pressure Laminate price group 1 • High-Pressure Laminate price group 3 <p>Base</p> <ul style="list-style-type: none"> • Paint price group 1 • Paint price group 2 	<p>Specify High-Pressure Laminate color number.</p> <p>Specify High-Pressure Laminate color number.</p> <p>Specify paint color number.</p> <p>Specify paint color number.</p>
<p>Column Base</p> <ul style="list-style-type: none"> • 30"W tops • 36"W tops • 42"W–54"W tops • 60"W–72"W tops 	<p>Specify <i>with column</i>.</p> <p>Specify <i>with column</i>.</p> <p>Specify <i>with column</i>.</p> <p>Specify <i>with column</i>.</p>
<p>Casters for Post Legs</p> <ul style="list-style-type: none"> • Four casters (two locking and two non-locking) 	<p>Specify <i>with casters</i>.</p>

Specification Information

Style Number	Dimensions Modular Depth	Modular Width	30"W	36"W	42"W	48"W	54"W	60"W	66"W	72"W



Low-Pressure Laminate

TS4WREC	24"		•	•	•	•	•	•	•	•
<i>Tip: For modular rectangle sizes, width must be greater than depth. Please refer to TS4WSQ for modular square size selections.</i>	30"		•	•	•	•	•	•	•	•
	36"		N.A.	•	•	•	•	•	•	•
	42"		N.A.	N.A.	•	•	•	•	•	•

High-Pressure Laminate Price Group 1

TS4WREC	24"		•	•	•	•	•	•	•	•
	30"		•	•	•	•	•	•	•	•
	36"		N.A.	•	•	•	•	•	•	•
	42"		N.A.	N.A.	•	•	•	•	•	•

High-Pressure Laminate Price Group 3

TS4WREC	24"		•	•	•	•	•	•	•	•
	30"		•	•	•	•	•	•	•	•
	36"		N.A.	•	•	•	•	•	•	•
	42"		N.A.	N.A.	•	•	•	•	•	•

Simple Working-Height Soft Square Tables

28¹/₂"H



Tip: Reinforcing channel (TSATRC57), ordered separately, must be used on tables with post legs that have 60" or more of unsupported knee space.

Tip: Tops 36"W and over get a 5" column. Tops 60"W get two 5" columns.

Tip: Glides on post legs are 1¹/₂" long and provide 1" of leveling.

Standard Includes	Required to Specify
<ul style="list-style-type: none"> ▶ See <i>Conference and Collaborative Tables Specification Guide</i> for product details. • 1¹/₈" thick table top: Low-Pressure Laminate (LPL) • Edge band: default color to match laminate • Post legs: paint price group 1 • Glides, if post legs are selected 	<ol style="list-style-type: none"> 1 Style number 2 Worksurface size type (see below under Required Selections) 3 Width (see below under Required Selections) 4 Low-Pressure Laminate color number for table top 5 Paint color number for post legs 6 Options, if selected (see below) <p>▶ See <i>Surface Materials</i>, page 480.</p>

Required Selections		Required to Specify
Width	Modular	
	<ul style="list-style-type: none"> • 36"W • 42"W • 48"W • 54"W • 60"W 	<p>Specify width.</p> <p>Specify width.</p> <p>Specify width.</p> <p>Specify width.</p>

Options		Required to Specify
Surface Materials	<p>High-Pressure Laminate top</p> <ul style="list-style-type: none"> • High-Pressure Laminate price group 1 • High-Pressure Laminate price group 3 <hr/> <p>Base</p> <ul style="list-style-type: none"> • Paint price group 1 • Paint price group 2 	<p>Specify High-Pressure Laminate color number.</p> <p>Specify High-Pressure Laminate color number.</p> <hr/> <p>Specify paint color number.</p> <p>Specify paint color number.</p>
Column Base	<ul style="list-style-type: none"> • 36"W tops • 42"W–54"W tops • 60"W tops 	<p>Specify <i>with column</i>.</p> <p>Specify <i>with column</i>.</p> <p>Specify <i>with column</i>.</p>
Casters for Post Legs	<ul style="list-style-type: none"> • Four casters (two locking and two non-locking) 	<p>Specify <i>with casters</i>.</p>

Specification Information

Style Number	Dimensions Modular Width
--------------	--------------------------



Low-Pressure Laminate

TS4WSFTSQ	36"
	42"
	48"
	54"
	60"

High-Pressure Laminate Price Group 1

TS4WSFTSQ	36"
	42"
	48"
	54"
	60"

High-Pressure Laminate Price Group 3

TS4WSFTSQ	36"
	42"
	48"
	54"
	60"

Simple Working-Height Soft Rectangle Tables

28¹/₂"H

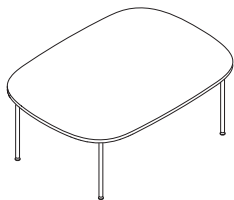

Standard Includes	Required to Specify
<ul style="list-style-type: none"> ▶ See <i>Conference and Collaborative Tables Specification Guide</i> for product details. • 1 1/8" thick table top: Low-Pressure Laminate (LPL) • Edge band: default color to match laminate • Post legs: paint price group 1 • Glides, if post legs are selected 	<ol style="list-style-type: none"> 1 Style number 2 Worksurface size type (see below under Required Selections) 3 Depth (see below under Required Selections) 4 Width (see below under Required Selections) 5 Low-Pressure Laminate color number for table top 6 Paint color number 7 Options, if selected (see below) <p>▶ See <i>Surface Materials</i>, page 480.</p>

Required Selections		Required to Specify
Depth	Modular <ul style="list-style-type: none"> • 36"D • 42"D • 48"D • 54"D • 60"D 	Specify depth. Specify depth. Specify depth. Specify depth. Specify depth.
Width	Modular <ul style="list-style-type: none"> • 36"W • 42"W • 48"W • 54"W • 60"W • 66"W • 72"W 	Specify width. Specify width. Specify width. Specify width. Specify width. Specify width. Specify width.

Options		Required to Specify
Surface Materials	High-Pressure Laminate top <ul style="list-style-type: none"> • High-Pressure Laminate price group 1 • High-Pressure Laminate price group 3 	Specify High-Pressure Laminate color number. Specify High-Pressure Laminate color number.
	Base <ul style="list-style-type: none"> • Paint price group 1 • Paint price group 2 	Specify paint color number. Specify paint color number.
Column Base	<ul style="list-style-type: none"> • 36"W tops • 42"W–54"W tops • 60"W tops 	Specify <i>with column</i> . Specify <i>with column</i> . Specify <i>with column</i> .

Casters for Post Legs	<ul style="list-style-type: none"> • Four casters (two locking and two non-locking) 	Specify <i>with casters</i> .
------------------------------	--	-------------------------------

Tip: Tops 36"W and over get a 5" column. Tops 60"W and over get two 5" columns.

Tip: Reinforcing channel (TSATRC57), ordered separately, must be used on tables with post legs that have 60" or more of unsupported knee space.

Tip: Glides on post legs are 1 1/2" long and provide 1" of leveling.

Specification Information

Style Number	Dimensions Modular Depth	Modular Width	36"W	42"W	48"W	54"W	60"W	66"W	72"W

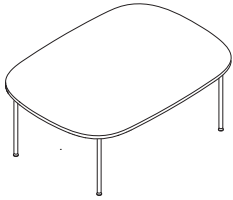

Low-Pressure Laminate

TS4WSFTREC <i>Tip: For modular rectangle sizes, width must be greater than depth. Please refer to TS4WSFTSQ for modular square size selections.</i>	36"	•	•	•	•	•	•	•	•
	42"	N.A.	•	•	•	•	•	•	•
	48"	N.A.	N.A.	•	•	•	•	•	•
	54"	N.A.	N.A.	N.A.	•	•	•	•	•
	60"	N.A.	N.A.	N.A.	N.A.	•	•	•	•
	:	:	:	:	:	:	:	:	:

High-Pressure Laminate Price Group 1

TS4WSFTREC	36"	•	•	•	•	•	•	•	•
	42"	N.A.	•	•	•	•	•	•	•
	48"	N.A.	N.A.	•	•	•	•	•	•
	54"	N.A.	N.A.	N.A.	•	•	•	•	•
	60"	N.A.	N.A.	N.A.	N.A.	•	•	•	•
	:	:	:	:	:	:	:	:	:

High-Pressure Laminate Price Group 3

TS4WSFTREC	36"	•	•	•	•	•	•	•	•
	42"	N.A.	•	•	•	•	•	•	•
	48"	N.A.	N.A.	•	•	•	•	•	•
	54"	N.A.	N.A.	N.A.	•	•	•	•	•
	60"	N.A.	N.A.	N.A.	N.A.	•	•	•	•
	:	:	:	:	:	:	:	:	:

Simple Café-Height Round Tables

42"H



Tip: Tops under 30"W get a 3" column. Tops 36"W get a 5" column.

Standard Includes	Required to Specify
<ul style="list-style-type: none"> ▶ See <i>Conference and Collaborative Tables Specification Guide</i> for product details. • 1 1/8" thick table top: Low-Pressure Laminate (LPL) • Edge band: default color to match laminate • Base and column: paint price group 1 	<ol style="list-style-type: none"> 1 Style number 2 Worksurface size type (see below under Required Selections) 3 Diameter (see below under Required Selections) 4 Low-Pressure Laminate color number for table top 5 Paint color number for base and column 6 Options, if selected (see below) <p>▶ See <i>Surface Materials</i>, page 480.</p>

Required Selections		Required to Specify
Diameter	Modular	
	<ul style="list-style-type: none"> • 30"D • 36"D 	<p>Specify diameter.</p> <p>Specify diameter.</p>

Options		Required to Specify
Surface Materials	High-Pressure Laminate top	
	<ul style="list-style-type: none"> • High-Pressure Laminate price group 1 • High-Pressure Laminate price group 3 	<p>Specify High-Pressure Laminate color number.</p> <p>Specify High-Pressure Laminate color number.</p>
	Base and column	
	<ul style="list-style-type: none"> • Paint price group 1 • Paint price group 2 	<p>Specify paint color number.</p> <p>Specify paint color number.</p>

Specification Information	
• Style Number	• Dimensions
:	• Modular
:	• Depth
:	:
:	:

Low-Pressure Laminate

TS4WRDCAFE	30"
	36"
:	:

High-Pressure Laminate Price Group 1

TS4WRDCAFE	30"
	36"
:	:

High-Pressure Laminate Price Group 3

TS4WRDCAFE	30"
	36"
:	:

Simple Café-Height Square Tables

42"H

Simple Café-Height
Square Tables

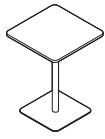

Tip: Tops under 30"W get a 3" column. Tops 36"W get a 5" column.

Standard Includes	Required to Specify
<ul style="list-style-type: none"> ▶ See <i>Conference and Collaborative Tables Specification Guide</i> for product details. • 1 1/8" thick table top: Low-Pressure Laminate (LPL) • Edge band: default color to match laminate • Base and column: paint price group 1 	<ol style="list-style-type: none"> 1 Style number 2 Worksurface size type (see below under Required Selections) 3 Width (see below under Required Selections) 4 Low-Pressure Laminate color number for table top 5 Paint color number for base and column 6 Options, if selected (see below) <p>▶ See <i>Surface Materials</i>, page 480.</p>

Required Selections	Required to Specify
Width Modular <ul style="list-style-type: none"> • 30"W • 36"W 	Specify width. Specify width.

Options	Required to Specify
Surface Materials High-Pressure Laminate top <ul style="list-style-type: none"> • High-Pressure Laminate price group 1 • High-Pressure Laminate price group 3 <hr/> Base and column <ul style="list-style-type: none"> • Paint price group 1 • Paint price group 2 	Specify High-Pressure Laminate color number. Specify High-Pressure Laminate color number. <hr/> Specify paint color number. Specify paint color number.

Specification Information	
• Style Number	• Dimensions
•	• Modular
•	• Depth
•	•

Low-Pressure Laminate	
TS4WSQCAFE	30"
	36"
	:

High-Pressure Laminate Price Group 1	
TS4WSQCAFE	30"
	36"
	:

High-Pressure Laminate Price Group 3	
TS4WSQCAFE	30"
	36"
	:

Conference and Collaborative Tables

Reinforcing Channel

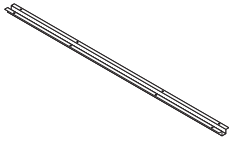

Standard Includes	Required to Specify
-------------------	---------------------

▶ See *Conference and Collaborative Tables Specification Guide* for product details.

Style number

Specification Information	
---------------------------	--

<p>• Dimensions</p> <p>•</p> <p>•</p> <p>•</p>	<p>• Style Number</p> <p>•</p> <p>•</p> <p>•</p>
<p>57"W</p> <p>•</p> <p>•</p>	<p>TSATRC57</p> <p>•</p> <p>•</p>

Universal Straight Tables

High-Pressure Laminate

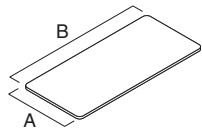

Tip: Select the reinforcing channel option if the table will be supported by legs. Channels are not required if the table will be supported by T- or X-bases.

Tip: Bases and legs to support Universal Tables must be specified separately.

Tip: For base and leg support guidelines, see Conference and Collaborative Tables Specification Guide.

Standard Includes	Required to Specify
<ul style="list-style-type: none"> See <i>Conference and Collaborative Tables Specification Guide</i> for product details. Table: High-Pressure Laminate price group 1 Laminate table: plastic 3 mm edge profile on all sides 	<ol style="list-style-type: none"> Style number High-Pressure Laminate color number for table Plastic color number for edge Options, if selected (see below) <p>▶ See <i>Surface Materials</i>, page 480.</p>

Options	Required to Specify
Surface Materials <ul style="list-style-type: none"> Laminate price group 3 	Specify laminate color number.
Reinforcing Channel <ul style="list-style-type: none"> Reinforcing channel (available on 66"W and wider tables) 	Specify with reinforcing channel.

Specification Information

Dimensions		Style Number	High-Pressure Laminate
A	B		
24"	29 ³ / ₄ "	BFS2430	•
24"	35 ³ / ₄ "	BFS2436	•
24"	41 ³ / ₄ "	BFS2442	•
24"	47 ³ / ₄ "	BFS2448	•
24"	53 ³ / ₄ "	BFS2454	•
24"	59 ³ / ₄ "	BFS2460	•
24"	65 ³ / ₄ "	BFS2466	•
24"	71 ³ / ₄ "	BFS2472	•
24"	77 ³ / ₄ "	BFS2478	•
30"	35 ³ / ₄ "	BFS3036	•
30"	41 ³ / ₄ "	BFS3042	•
30"	47 ³ / ₄ "	BFS3048	•
30"	53 ³ / ₄ "	BFS3054	•
30"	59 ³ / ₄ "	BFS3060	•
30"	65 ³ / ₄ "	BFS3066	•
30"	71 ³ / ₄ "	BFS3072	•
30"	77 ³ / ₄ "	BFS3078	•

Conference and Collaborative Tables

Universal Round Tables

High-Pressure Laminate



Standard Includes	Required to Specify
<ul style="list-style-type: none"> ▶ See <i>Conference and Collaborative Tables Specification Guide</i> for product details. • Table: High-Pressure Laminate price group 1 • Laminate table: plastic 3 mm edge profile on all sides 	<ul style="list-style-type: none"> 1 Style number 2 High-Pressure Laminate color number for table 3 Plastic color number for edge on laminate table 4 Options, if selected (see below) ▶ See <i>Surface Materials</i>, page 480.

Options	Required to Specify
<p>Surface Materials</p> <ul style="list-style-type: none"> • Laminate price group 3 	Specify laminate color number.

Specification Information		
• Diameter	• Style Number	• Plastic 3 mm Edge
30"	BFR30	•
36"	BFR36	•
42"	BFR42	•
48"	BFR48	•
54"	BFR54	•
:	:	:

High-Pressure Laminate



Tip: Bases and legs to support Universal Tables must be specified separately.

Tip: For base and leg support guidelines,
 ▶ See *Conference and Collaborative Tables Specification Guide*.

Universal Square Tables

High-Pressure Laminate

Universal Square Tables

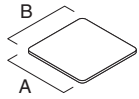

Standard Includes	Required to Specify
<ul style="list-style-type: none"> See <i>Conference and Collaborative Tables Specification Guide</i> for product details. Table: High-Pressure Laminate price group 1 Laminate table: plastic 3 mm edge profile on all sides 	<ul style="list-style-type: none"> 1 Style number 2 High-Pressure Laminate color number for table 3 Plastic color number for edge on laminate table <p>▶ See <i>Surface Materials</i>, page 480.</p>

Options	Required to Specify
<p>Surface Materials</p> <ul style="list-style-type: none"> Laminate price group 3 	Specify laminate color number.

Tip: Bases and legs to support Universal Tables must be specified separately.

Tip: For base and leg support guidelines, ▶ See *Conference and Collaborative Tables Specification Guide*.

Specification Information

Dimensions		Style Number	High-Pressure Laminate
A	B		Plastic 3 mm Edge
24"	24"	BFRQ24	•
30"	30"	BFRQ30	•
36"	36"	BFRQ36	•
42"	42"	BFRQ42	•
48"	48"	BFRQ48	•
54"	54"	BFRQ54	•
:	:	:	:

Conference and Collaborative Tables

Universal Rectangle Tables

High-Pressure Laminate

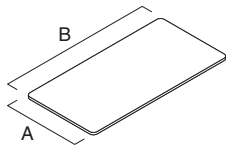

Tip: Select the reinforcing channel option if the table will be supported by legs. Channels are not required if the table will be supported by T- or X-bases.

Tip: Bases and legs to support Universal Tables must be specified separately.

Tip: For base and leg support guidelines, see Conference and Collaborative Tables Specification Guide.

Standard Includes	Required to Specify
<ul style="list-style-type: none"> See <i>Conference and Collaborative Tables Specification Guide</i> for product details. Table: High-Pressure Laminate price group 1 Laminate table: plastic 3 mm edge profile on all sides 	<ol style="list-style-type: none"> Style number High-Pressure Laminate color number for table Plastic color number for edge on laminate table Options, if selected (see below) <p>▶ See <i>Surface Materials</i>, page 480.</p>

Options	Required to Specify
Surface Materials <ul style="list-style-type: none"> Laminate price group 3 	Specify laminate color number.
Reinforcing Channel <ul style="list-style-type: none"> Reinforcing channel (available on 66"W and wider tables) 	Specify <i>with reinforcing channel</i> .

Specification Information		
Dimensions	Style Number	High-Pressure Laminate
A B		Plastic 3 mm Edge
36" 60"	BFRR3660	•
36" 66"	BFRR3666	•
36" 72"	BFRR3672	•
42" 84"	BFRR4284	•
48" 96"	BFRR4896	•
:	:	:



Standard Includes	Required to Specify
<ul style="list-style-type: none"> ▶ See <i>Conference and Collaborative Tables Specification Guide</i> for product details. • Column: paint • Base: paint • Adjustable leveling glides: black plastic 	<ul style="list-style-type: none"> 1 Style number 2 Paint color number for column 3 Paint color number for base 4 Options, if selected (see below) ▶ See <i>Surface Materials</i>, page 480.

Options	Required to Specify				
<table border="0"> <tr> <td style="vertical-align: top;">Surface Materials</td> <td style="vertical-align: top;">Base</td> </tr> <tr> <td></td> <td> <ul style="list-style-type: none"> • Paint price group 1 • Paint price group 2 </td> </tr> </table>	Surface Materials	Base		<ul style="list-style-type: none"> • Paint price group 1 • Paint price group 2 	<ul style="list-style-type: none"> Specify paint color number Specify paint color number.
Surface Materials	Base				
	<ul style="list-style-type: none"> • Paint price group 1 • Paint price group 2 				

Specification Information

• Width	• Column Diameter	• Style Number
•	•	•
•	•	•
•	•	•

T-Bases		
26"	2 1/4"	BT26
36"	2 1/4"	BT36
•	•	•

X-Bases		
26"	2 1/4"	BX26
36"	2 1/4"	BX36
•	•	•

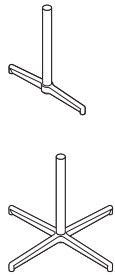

Conference and Collaborative Tables

Universal Tables Post Legs

With Alignment Tab

Standard Includes	Required to Specify
<ul style="list-style-type: none"> ▶ See <i>Conference and Collaborative Tables Specification Guide</i> for product details. • Table legs: paint • Attachment hardware • Non-locking caster, if selected: black plastic only 	<ul style="list-style-type: none"> 1 Style number 2 Paint color number for legs 3 Options, if selected (see below) ▶ See <i>Surface Materials</i>, page 480.

Options	Required to Specify
Surface Materials <ul style="list-style-type: none"> • Paint price group 1 • Paint price group 2 	<ul style="list-style-type: none"> Specify paint color number. Specify paint color number.

Specification Information

Planning Height	Style Number	Planning Height	Style Number
Post Leg with Glide		Package of Four Post Legs with Glides	
28½"	BPL	28½"	BPL4
:	:	:	:
Post Leg with Caster		Package of Four Post Legs with Casters	
28½"	BPLC	28½"	BPL4C
:	:	:	:

Tip: Corner tables require a leg in the back corner. Be sure to order fifth leg if specifying a package of four.

Tip: Height dimensions listed are nominal and include the thickness of a table.



Verb Chevron Tables



Standard Includes	Required to Specify
<ul style="list-style-type: none"> ▶ See <i>Conference and Collaborative Tables Specification Guide</i> for product details. Table: 1½"- thick top, High-Pressure Laminate price group 1 3 mm radius profile edge: plastic Access legs with non-locking casters: paint group 1 	<ol style="list-style-type: none"> 1 Style number 2 High-Pressure Laminate color number for table 3 Plastic edge band color number for table 4 Paint color number for legs 5 Options, if selected (see below) <ul style="list-style-type: none"> ▶ See <i>Surface Materials</i>, page 480.

Options	Required to Specify
<p>Surface Materials</p> <p>Legs</p> <ul style="list-style-type: none"> • Paint price group 1 • Paint price group 2 <hr/> <p>Modesty panel</p> <ul style="list-style-type: none"> • Paint price group 1 • Paint price group 2 <hr/> <p>High-Pressure Laminate worksurfaces</p> <ul style="list-style-type: none"> • Laminate price group 3 	<p>Specify paint color number. Specify paint color number.</p> <hr/> <p>Specify paint color number. Specify paint color number.</p> <hr/> <p>Specify laminate color number.</p>
<p>Leg Options</p> <p>Access legs</p> <ul style="list-style-type: none"> • Locking casters • Glides • Two non-locking casters and two glides <hr/> <p>Seated height-adjustable post legs</p> <ul style="list-style-type: none"> • Non-locking casters • Locking casters • Glides • Two non-locking casters and two glides <hr/> <p>Standing height-adjustable post legs</p> <ul style="list-style-type: none"> • Glides 	<p>Specify <i>with access legs with locking casters.</i> Specify <i>with access legs with glides.</i> Specify <i>with access legs with two non-locking casters and two glides.</i></p> <hr/> <p>Specify <i>with seated height-adjustable post leg with non-locking casters.</i> Specify <i>with seated height-adjustable post leg with locking casters.</i> Specify <i>with seated height-adjustable post leg with glides.</i> Specify <i>with seated height-adjustable post leg with two non-locking casters and two glides.</i></p> <hr/> <p>Specify <i>with standing height-adjustable post leg with glides.</i></p>
<p>Modesty Panel</p> <ul style="list-style-type: none"> • Steel modesty panel 	<p>Specify <i>with modesty panel</i> and specify paint color number.</p>
<p>Dock Storage Options</p> <ul style="list-style-type: none"> • No dock • Side dock and hook (two sets) • Side dock, hook, and center storage dock • Center storage dock 	<p>Specify <i>with no dock.</i> Specify <i>with dock and side hook</i> (two sets) and specify plastic finish. Specify <i>with dock, hook, and center storage dock</i> and specify plastic finish. Specify <i>with center storage dock</i> and specify plastic finish.</p>
<p>Reinforcing Channel</p> <ul style="list-style-type: none"> • Reinforcing channel 	<p>Specify <i>with reinforcing channel.</i></p>

Tip: On 19"D tables, only seated height-adjustable post legs with glides are available.

Tip: Reinforcing channel is not needed on tops smaller than 60" or when a modesty panel is specified.

Specification Information

Dimensions		Style Number	Options				Standing Height-Adjustable Post Legs
D	W		Seated Height-Adjustable Post Legs				
			with Non-Locking Casters	with Locking Casters	with Glides	with Two Casters and Two Glides	with Glides
19"	60"	VTC1960	N.A.	N.A.	•	N.A.	N.A.
24"	60"	VTC2460	•	•	•	•	•



Conference and Collaborative Tables

Verb Team Table



Standard Includes	Required to Specify
<ul style="list-style-type: none"> ▶ See <i>Conference and Collaborative Tables Specification Guide</i> for product details. Table: 1½"- thick top, High-Pressure Laminate price group 1 3 mm radius profile edge: plastic Access legs with non-locking casters: paint group 1 	<ol style="list-style-type: none"> 1 Style number 2 High-Pressure Laminate color number for table 3 Plastic edge band color number for table 4 Paint color number for legs 5 Options, if selected (see below) <ul style="list-style-type: none"> ▶ See <i>Surface Materials</i>, page 480.

Options	Required to Specify
Surface Materials <ul style="list-style-type: none"> Legs <ul style="list-style-type: none"> • Paint price group 1 • Paint price group 2 High-Pressure Laminate worksurfaces <ul style="list-style-type: none"> • Laminate price group 3 	<ul style="list-style-type: none"> Specify paint color number. Specify paint color number. Specify laminate color number.
Leg Options <ul style="list-style-type: none"> Access legs <ul style="list-style-type: none"> • Locking casters • Glides • Two non-locking casters and two glides Seated height-adjustable post legs <ul style="list-style-type: none"> • Non-locking casters • Locking casters • Glides • Two non-locking casters, two glides Standing height-adjustable post legs <ul style="list-style-type: none"> • Glides 	<ul style="list-style-type: none"> Specify <i>with access legs with locking casters.</i> Specify <i>with access legs with glides.</i> Specify <i>with access legs with two non-locking casters and two glides.</i> Specify <i>with seated height-adjustable post leg with non-locking casters.</i> Specify <i>with seated height-adjustable post leg with locking casters.</i> Specify <i>with seated height-adjustable post leg with glides.</i> Specify <i>with seated height-adjustable post leg with two non-locking casters and two glides.</i> Specify <i>with standing height-adjustable post leg with glides.</i>
Dock Storage Options <ul style="list-style-type: none"> • No dock • Side dock and hook (two sets) 	<ul style="list-style-type: none"> Specify <i>with no dock.</i> Specify <i>with dock and hook (two sets)</i> and specify plastic finish.
Reinforcing Channel <ul style="list-style-type: none"> • Reinforcing channel 	<ul style="list-style-type: none"> Specify <i>with reinforcing channel.</i>

Tip: Side docks may only be placed on the angled sides of the trapezoid table.

Specification Information							
Dimensions		Style	Options				
D	W	Number	Seated Height-Adjustable Post Legs				
			with Non-Locking Casters	with Locking Casters	with Glides	with Two Casters and Two Glides	Standing Height-Adjustable Post Legs
							with Glides

Team Table

24"	60"	VTT2460	•	•	•	•	•

Verb Rectangle Tables



Standard Includes	Required to Specify
<ul style="list-style-type: none"> ▶ See <i>Conference and Collaborative Tables Specification Guide</i> for product details. Table: 1½"-thick top, High-Pressure Laminate price group 1 3 mm radius profile edge: plastic Access legs with non-locking casters: paint group 1 	<ol style="list-style-type: none"> 1 Style number 2 High-Pressure Laminate color number for table 3 Plastic edge band color number for table 4 Paint color number for legs 5 Options, if selected (see below) <ul style="list-style-type: none"> ▶ See <i>Surface Materials</i>, page 480.

Options	Required to Specify
Surface Materials <ul style="list-style-type: none"> Legs <ul style="list-style-type: none"> Paint price group 1 Paint price group 2 Modesty panel <ul style="list-style-type: none"> Paint price group 1 Paint price group 2 High-Pressure Laminate worksurfaces <ul style="list-style-type: none"> Laminate price group 3 	<ul style="list-style-type: none"> Specify paint color number. Specify paint color number. Specify paint color number. Specify paint color number. Specify laminate color number.
Leg Options <ul style="list-style-type: none"> Access legs <ul style="list-style-type: none"> Locking casters Glides Two non-locking casters and two glides Seated height-adjustable post legs <ul style="list-style-type: none"> Non-locking casters Locking casters Glides Two non-locking casters, two glides Standing height-adjustable post legs <ul style="list-style-type: none"> Non-locking casters Locking casters Glides Two non-locking casters, two glides 	<ul style="list-style-type: none"> Specify <i>with access legs with locking casters.</i> Specify <i>with access legs with glides.</i> Specify <i>with access legs with two non-locking casters and two glides.</i> Specify <i>with seated height-adjustable post leg with non-locking casters.</i> Specify <i>with seated height-adjustable post leg with locking casters.</i> Specify <i>with seated height-adjustable post leg with glides.</i> Specify <i>with seated height-adjustable post leg with two non-locking casters and two glides.</i> Specify <i>with standing height-adjustable post leg with non-locking casters.</i> Specify <i>with standing height-adjustable post leg with locking casters.</i> Specify <i>with standing height-adjustable post leg with glides.</i> Specify <i>with standing height-adjustable post leg with two non-locking casters and two glides.</i>
Modesty Panel <ul style="list-style-type: none"> Steel modesty panel 	<ul style="list-style-type: none"> Specify <i>with modesty panel</i> and specify paint color number.
Dock Storage Options <ul style="list-style-type: none"> No dock Side dock and hook (two sets) Side dock, hook, and center storage dock on 60"-72" units Center storage dock on 72" units and smaller 	<ul style="list-style-type: none"> Specify <i>with no dock.</i> Specify <i>with dock and hook (two sets)</i> and specify plastic finish. Specify <i>with dock, hook, and center storage dock</i> and specify plastic finish. Specify <i>with center storage dock</i> and specify plastic finish.
Reinforcing Channel <ul style="list-style-type: none"> Reinforcing channel 	<ul style="list-style-type: none"> Specify <i>with reinforcing channel.</i>

Tip: On all 19"D tables only seated height-adjustable post legs with glides are available.

Tip: On tables 24"D with standing height-adjustable post legs and modesty panels, rectangle tables are only available with glides.

Tip: On tables with standing height-adjustable post legs and casters, rectangle tables 30"D x 48"-84"W, cannot be used with a modesty panel.

Specification Information

Dimensions		Style Number	Options							
D	W		Seated Height-Adjustable Post Legs				Standing Height-Adjustable Post Legs			
			with Non-Locking Casters	with Locking Casters	with Glides	with Two Casters and Two Glides	with Non-Locking Casters	with Locking Casters	with Glides	with Two Casters and Two Glides
19"	60"	VTR1960	N.A.	N.A.	•	N.A.	N.A.	N.A.	N.A.	N.A.
24"	60"	VTR2460	•	•	•	•	N.A.	N.A.	•	N.A.
24"	72"	VTR2472	•	•	•	•	N.A.	N.A.	•	N.A.
30"	60"	VTR3060	•	•	•	•	•	•	•	•
30"	72"	VTR3072	•	•	•	•	•	•	•	•
:	:	:	:	:	:	:	:	:	:	:



Conference and Collaborative Tables

Potrero415 Collaborative and Conference Table Round Table with Metal Legs

DESIGN COALESSE DESIGN GROUP



Standard Includes	Required to Specify
<ul style="list-style-type: none"> ▶ See <i>Coalesse Tables, Storage, and Accessories Specification Guide</i> for product details. Table top: group 1 laminate with 3 mm flat plastic edge Legs and frame: group 1 paint Leg ring: paint Four adjustable glides Ships ready to assemble 	<ol style="list-style-type: none"> Style number Table top diameter for round table Laminate color number for table top Plastic edge color number for laminate table top, if selected Paint color number for legs and frame Paint color number for leg ring Options, if selected (see below) <ul style="list-style-type: none"> ▶ See <i>Surface Materials</i>, page 480.

Options	Required to Specify
<p>Surface Materials</p> <ul style="list-style-type: none"> Table top <ul style="list-style-type: none"> Group 2 laminate Group 3 laminate Group 1 composite veneer Group 2 composite veneer Group 1 wood veneer Group 2 wood veneer Solid surface 	<p>Specify with group 2 laminate and select color number. Specify with group 3 laminate and select color number. Specify with group 1 composite veneer and select color number. Specify with group 2 composite veneer and select color number. Specify with group 1 wood veneer and select color number. Specify with group 2 wood veneer and select color number. Specify with solid surface group 1 and select color number for substructure (6000 Black or 6052 Milk).</p>
<p>Legs on work-height tables</p> <ul style="list-style-type: none"> Group 3 paint Polished aluminum 	<p>Specify paint color number. Specify with 8046 Polished Aluminum.</p>
<p>Leg ring</p> <ul style="list-style-type: none"> Chrome or copper plating 	<p>Specify 9201 Chrome, 9260 Black Chrome, or 9261 Copper.</p>
<p>Technology Devices and Grommets</p> <ul style="list-style-type: none"> PowerPod grommet for 48" tables <ul style="list-style-type: none"> PowerPod grommet Round power module for 48" tables <ul style="list-style-type: none"> Two receptacles One receptacle/one USB 	<p>Specify with PowerPod grommet and select finish.</p> <p>Specify with round power module with two receptacles and select finish. Specify with round power module with one receptacle/one USB and select finish.</p>

Tip: For tables with solid surface overall height is 1/2" taller.

Tip: When polished aluminum leg is specified, frame is platinum gloss.

Tip: When "no infeed" is selected, each technology device is equipped with a 6' conduit to be hardwired on site.

Tip: PowerPod grommet is available in 6000 Black or 6052 Milk.

Tip: Round power module is available in silver, milk, black and graphite finishes.

Tip: When technology is specified on 48" round tables only, the 15-amp power module cord can be managed from the desk top through a leg. Order leg cover thumb screws through Service Parts (1025537001SR) to allow for tool-free access.

Specification Information

Style Number	Dimensions		Laminate		Composite Veneer		Wood Veneer		Solid Surface
	Dia.	H	Group 1	Group 2	Group 1	Group 2	Group 1	Group 2	

Work-Height Round Table

COFOFRD	48"	28 1/2"	•	•	•	•	•	•	•
---------	-----	---------	---	---	---	---	---	---	---

Potrero415 Collaborative and Conference Tables

72"L, 96"L, and 120"L
Rectangular Tables with Metal Legs

DESIGN COALESSE DESIGN GROUP

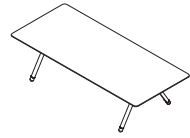

Tip: Large tops can be difficult to move through some buildings. If top dimensions are too large for installation site, please contact Specials for assistance with creating smaller top sections.

Tip: For tables with solid surface tops, overall height is 1/2" taller.

Tip: When polished aluminum leg is specified, frame is platinum gloss.

Tip: PowerPod grommet is available in 6000 Black or 6052 Milk.

Tip: Square power module is available in 8047 Silver Anodized Aluminum.

Standard Includes		Required to Specify
<ul style="list-style-type: none"> ▶ See <i>Coalesse Tables, Storage, and Accessories Specification Guide</i> for product details. Table top: group 1 laminate with 3 mm flat plastic edge Legs and frame: group 1 paint Leg ring: paint Four adjustable glides Ships ready to assemble 		<ol style="list-style-type: none"> Style number Table top depth and width Laminate color number for table top Plastic edge color number for laminate table top, if selected Paint color number for legs and frame Paint color number for leg ring Options, if selected (see below) <p>▶ See <i>Surface Materials</i>, page 480.</p>
Options		Required to Specify
Surface Materials	Table top <ul style="list-style-type: none"> Group 2 laminate Group 3 laminate Group 1 composite veneer Group 2 composite veneer Group 1 wood veneer Group 2 wood veneer Solid surface 	Specify with <i>group 2 laminate</i> and select color number. Specify with <i>group 3 laminate</i> and select color number. Specify with <i>group 1 composite veneer</i> and select color number. Specify with <i>group 2 composite veneer</i> and select color number. Specify with <i>group 1 wood veneer</i> and select color number. Specify with <i>group 2 wood veneer</i> and select color number. Specify with <i>solid surface group 1</i> and select color number for substructure (6000 Black or 6052 Milk).
	Legs on work-height tables <ul style="list-style-type: none"> Group 3 paint Polished aluminum 	Specify paint color number. Specify with <i>8046 Polished Aluminum</i> .
	Leg ring <ul style="list-style-type: none"> Chrome 	Specify 9201 Chrome.
Technology Devices and Grommets	PowerPod grommet <ul style="list-style-type: none"> PowerPod grommet 	Specify with <i>PowerPod grommet</i> , select finish, device count, and device location (see next page for location options).
	Square power module/E2X power unit <ul style="list-style-type: none"> Six power/two USB/two data 	Specify with <i>square power module with six power/two USB/two data, device count, device location, and select finish</i> .

Specification Information

Style Number	Dimensions			Laminate		Composite Veneer		Wood Veneer		Solid Surface
	D	W	H	Group 1	Group 2 and 3	Group 1	Group 2	Group 1	Group 2	

Work-Height Rectangular Tables

COFOFREC	48"	72"	28 1/2"	•	•	•	•	•	•	•
	48"	96"	28 1/2"	•	•	•	•	•	•	•
	48"	120"	28 1/2"	•	•	•	•	•	•	•

Conference and Collaborative Tables

Potrero415 Light Collaborative and Conference Tables

DESIGN COALESSE DESIGN GROUP

Round Table
with Metal Legs



Standard Includes		Required to Specify
<ul style="list-style-type: none"> ▶ See <i>Coalesse Tables, Storage, and Accessories Specification Guide</i> for product details. 	<ul style="list-style-type: none"> • Table top: group 1 laminate with 3 mm flat plastic edge • Legs and frame: group 1 paint • Leg rings, height adjustable: group 1 paint • Ships ready to assemble • Bottom tray with cutouts 	<ol style="list-style-type: none"> 1 Style number 2 Table top diameter for round table 3 Laminate color number for table top 4 Plastic edge color number for laminate table top, if selected 5 Options, if selected (see below) <ul style="list-style-type: none"> ▶ See <i>Surface Materials</i>, page 480.

Options		Required to Specify
Surface Materials	Table top <ul style="list-style-type: none"> • Group 1 wood veneer 	Specify with group 1 wood veneer and select color number.
Bottom Tray	<ul style="list-style-type: none"> • Without bottom tray 	Specify with no bottom tray.
Technology Devices and Grommets	PowerPod grommet <ul style="list-style-type: none"> • PowerPod grommet <hr/> Power and USB module <ul style="list-style-type: none"> • One power • One USB A/C 	Specify with PowerPod grommet and select finish. Specify with power module with one power and select finish. Specify with power module with one USB and select finish.

Tip: If PowerPod is specified, consider cable routing details to ensure cord length is adequate to reach building power.

Tip: Bottom tray conceals cords and provides a clean visual.

Tip: PowerPod grommet is available in 6000 Black or 6052 Milk.

Tip: Power and USB modules are available in 6000 Black, 6052 Milk, or 6D03 Graphite.

Specification Information				
Style Number	Dimensions Dia.	H	Laminate Group 1	Wood Veneer Group 1

Work-Height Round Light Tables, Metal Legs

COFOFLRD	42"	28 ¹ / ₂ "	•	•
----------	-----	----------------------------------	---	---

Potrero415 Light Collaborative and Conference Tables

DESIGN COALESSE DESIGN GROUP

Round Table
with Metal Legs

Conference and
Collaborative Tables

Potrero415 Light Collaborative and Conference Tables

DESIGN COALESSE DESIGN GROUP

Rectangular Tables with Metal Legs

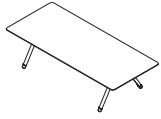

Standard Includes		Required to Specify
<ul style="list-style-type: none"> ▶ See <i>Coalesce Tables, Storage, and Accessories Specification Guide</i> for product details. 	<ul style="list-style-type: none"> Table top: group 1 laminate with 3 mm flat plastic edge Legs and frame: group 1 paint Leg rings, height adjustable: group 1 paint Ships ready to assemble Bottom tray with cutouts 	<ol style="list-style-type: none"> Style number Table top depth and width Laminate color number for table top Plastic edge color number for laminate table top, if selected Paint color number for legs and frame Paint color number for leg ring Options, if selected (see below) <ul style="list-style-type: none"> ▶ See <i>Surface Materials</i>, page 480.

Options		Required to Specify
Surface Materials	Table top <ul style="list-style-type: none"> Group 1 wood veneer 	Specify with group 1 wood veneer and select color number.
Bottom Tray	60"W and 72"W tables <ul style="list-style-type: none"> Without bottom tray 	Specify with no bottom tray..
Power Module and Grommets	PowerPod grommet for 30"D and 36"D tables <ul style="list-style-type: none"> PowerPod grommet 	Specify with PowerPod grommet and select finish.
	One power module, centered or end location <ul style="list-style-type: none"> One power One USB A/C 	Specify with power module, one power, device location, and select finish. Specify with power module, one USB, device location, and select finish.
	Two power modules, end locations <ul style="list-style-type: none"> Two power One power, one USB A/C Two USB A/C 	Specify with power module, two power, and select finish. Specify with power module, one power and one USB, and select finish. Specify with power module, two USB, and select finish.
	Three power modules, centered and end locations <ul style="list-style-type: none"> Three power Two power, one USB A/C Two USB A/C, one power Three USB A/C 	Specify with power module, three power, and select finish. Specify with power module, two power and one USB, and select finish. Specify with power module, two USB and one power, and select finish. Specify with power module, three USB, and select finish.

Tip: Bottom tray conceals cords and provides a clean visual.

Tip: PowerPod grommet is available in 6000 Black or 6052 Milk.

Tip: Power and USB modules are available in 6000 Black, 6052 Milk, or 6D03 Graphite.

Potrero415 Light Collaborative and Conference Tables

DESIGN COALESSE DESIGN GROUP

Rectangular Tables with Metal Legs

Specification Information

Style Number	Dimensions			Laminate Group 1	Wood Veneer Group 1
	D	W	H		

Work-Height Rectangular Light Tables, Metal Legs

COFOFLREC	24"	54"	28½"	•	•
	24"	60"	28½"	•	•
	24"	72"	28½"	•	•
	30"	54"	28½"	•	•
	30"	60"	28½"	•	•
	30"	72"	28½"	•	•
	36"	54"	28½"	•	•
	36"	60"	28½"	•	•
	36"	72"	28½"	•	•

Standing-Height Rectangular Light Tables, Metal Legs

COFOFLRECST	24"	54"	40"	•	•
	24"	60"	40"	•	•
	24"	72"	40"	•	•
	30"	54"	40"	•	•
	30"	60"	40"	•	•
	30"	72"	40"	•	•
	36"	54"	40"	•	•
	36"	60"	40"	•	•
	36"	72"	40"	•	•

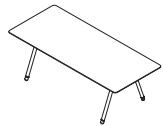
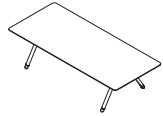

Conference and Collaborative Tables

Potrero415 Light Collaborative and Conference Tables

DESIGN COALESSE DESIGN GROUP

Rectangular Tables with Wood Legs

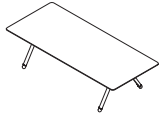

Standard Includes		Required to Specify
<ul style="list-style-type: none"> ▶ See <i>Coalesce Tables, Storage, and Accessories Specification Guide</i> for product details. 	<ul style="list-style-type: none"> Table top: group 1 laminate with 3 mm flat plastic edge Legs: solid oak Leg rings: group 1 paint Frame: group 1 paint Four height-adjustable glides Ships ready to assemble Bottom tray with cutouts 	<ol style="list-style-type: none"> Style number Table top depth and width Laminate color number for table top Plastic edge color number for laminate table top, if selected Paint color number for frame Paint color number for leg ring Options, if selected (see below) <ul style="list-style-type: none"> ▶ See <i>Surface Materials</i>, page 480.

Options		Required to Specify
Surface Materials	Table top <ul style="list-style-type: none"> Group 1 wood veneer 	Specify with group 1 wood veneer and select color number.
	Leg ring <ul style="list-style-type: none"> Chrome 	Specify 9201 Chrome.
Bottom tray	60"W and 72"W tables <ul style="list-style-type: none"> Without bottom tray 	Specify with no bottom tray.
Power Module and Grommets	PowerPod grommet for 30"D and 36"D tables <ul style="list-style-type: none"> PowerPod grommet 	Specify with PowerPod grommet and select finish.
	One power module, centered or end location <ul style="list-style-type: none"> One power One USB A/C 	Specify with power module, one power, device location, and select finish. Specify with power module, one USB, device location, and select finish.
	Two power modules, end locations <ul style="list-style-type: none"> Two power One power, one USB A/C Two USB A/C 	Specify with power module, two power, and select finish. Specify with power module, one power and one USB, and select finish. Specify with power module, two USB, and select finish.
	Three power modules, centered and end locations <ul style="list-style-type: none"> Three power Two power, one USB A/C Two USB A/C, one power Three USB A/C 	Specify with power module, three power, and select finish. Specify with power module, two power and one USB, and select finish. Specify with power module, two USB and one power, and select finish. Specify with power module, three USB, and select finish.

Tip: Bottom tray conceals cords and provides a clean visual.

Tip: PowerPod grommet is available in 6000 Black or 6052 Milk.

Tip: Power and USB modules are available in 6000 Black, 6052 Milk, or 6D03 Graphite.

Potrero415 Light Collaborative and Conference Tables

DESIGN COALESSE DESIGN GROUP

Rectangular Tables with Wood Legs

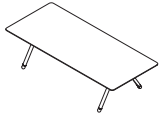

Specification Information

Style Number	Dimensions			Laminate Group 1	Wood Veneer Group 1
	D	W	H		

Work-Height Rectangular Light Tables, Wood Legs

COFOFLRECW	24"	54"	28½"	•	•
	24"	60"	28½"	•	•
	24"	72"	28½"	•	•
	30"	54"	28½"	•	•
	30"	60"	28½"	•	•
	30"	72"	28½"	•	•
	36"	54"	28½"	•	•
	36"	60"	28½"	•	•
	36"	72"	28½"	•	•
	36"	96"	28½"	•	•
	36"	120"	28½"	•	•

Conference and Collaborative Tables

Montara650 Café Table Work-Height Table

DESIGN COALESSE DESIGN GROUP

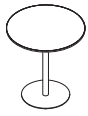

Standard Includes		Required to Specify
<p>► See <i>Coalesse Tables, Storage, and Accessories Specification Guide</i> for product details.</p>	<ul style="list-style-type: none"> Table top: <ul style="list-style-type: none"> - Group 1 laminate with 3 mm flat plastic edge - Wood veneer with matching flat edge Base: group 1 paint Glides Ships ready to assemble 	<ol style="list-style-type: none"> Style number Table top diameter for round table Laminate or wood veneer color number for table top Plastic edge color number for laminate table top, if selected Paint color number for base Options, if selected (see below) <p>► See <i>Surface Materials</i>, page 480.</p>

Options		Required to Specify
<p>Surface Materials</p>	<p>Table top</p> <ul style="list-style-type: none"> Group 3 laminate Group 2 wood veneer 	<p>Specify with <i>group 3 laminate</i> and select color number.</p> <p>Specify with <i>group 2 wood veneer</i> and select color number.</p>

Specification Information		
Style Number	Dimensions	
	Dia.	H

28½"H Round Café Table

COSFZWTRD	36"	28½"
-----------	-----	------

Montara650 Café Table Café-Height Table

DESIGN COALESSE DESIGN GROUP



Standard Includes	Required to Specify
<p>▶ See <i>Coalesse Tables, Storage, and Accessories Specification Guide</i> for product details.</p> <ul style="list-style-type: none"> Table top: <ul style="list-style-type: none"> Group 1 laminate with 3 mm flat plastic edge Wood veneer with matching flat edge Base: group 1 paint Glides Ships ready to assemble 	<ol style="list-style-type: none"> Style number Application (see below under Required Selections) Table top diameter for round table Laminate or wood veneer color number for table top Plastic edge color number for laminate top, if selected Paint color number for base Options, if selected (see below) <p>▶ See <i>Surface Materials</i>, page 480.</p>

Required Sections	Required to Specify
<p>Application</p> <ul style="list-style-type: none"> 36"H counter height table 42"H bar height table 	<p>Specify <i>with counter height</i>. Specify <i>with bar height</i>.</p>

Options	Required to Specify
<p>Surface Materials</p> <p>Table top</p> <ul style="list-style-type: none"> Group 3 laminate Group 2 wood veneer 	<p>Specify <i>with group 3 laminate</i> and select color number. Specify <i>with group 2 wood veneer</i> and select color number.</p>

Specification Information		
Style Number	Dimensions	
	Dia.	H
36"H Round Café Table		
COSFZCTRD	30"	36"

Conference and Collaborative Tables



Tip: This cable manager was designed to be used with the cutouts in the bottom tray to manage cables from trough to floor. It is compatible with the 30"D and 36"D Potrero415 light tables, with bottom tray specified.

Standard Includes	Required to Specify
-------------------	---------------------

<p>► See <i>Coalesse Tables, Storage, and Accessories Specification Guide</i> for product details.</p>	<ul style="list-style-type: none"> • Mesh cable manager: black mesh and 7202 Black paint
--	---

Style number

Specification Information

Style Number

Cable Manager, Mesh, Work Height

COFOFCABLM



Tip: The personal table is not intended for seating purposes, and has a load limit of 40 pounds.

Standard Includes	Required to Specify
-------------------	---------------------

<ul style="list-style-type: none"> ▶ See <i>Conference and Collaborative Tables Specification Guide</i> for product details. • Personal table: High-Pressure Laminate 	<ul style="list-style-type: none"> 1 Style number 2 High-Pressure Laminate color number for table: <ul style="list-style-type: none"> 2535 Virginia Walnut 2730 Arctic White 2HAT Acacia
---	--

Specification Information			
•Dimensions			•Style
D	W	H	Number

19½"	14"	26"	TS4TWP
------	-----	-----	---------------

Campfire Skate Table



Standard Includes		Required to Specify
<ul style="list-style-type: none"> ▶ See <i>Conference and Collaborative Tables Specification Guide</i> for product details. 	<ul style="list-style-type: none"> • 1/2" thick top and sides: High-Pressure Laminate price group 1 • 3 mm radius edge band on top: plastic • Steel base: paint • Cord grommet: 6527 Merle • Glides: 6527 Merle • Skate wheels: 6527 Merle • Shipped ready to assemble 	<ol style="list-style-type: none"> 1 Style number 2 High-Pressure Laminate color number for top 3 Plastic color number for edge 4 Paint color number for steel base 5 Options, if selected (see below) <ul style="list-style-type: none"> ▶ See <i>Surface Materials</i>, page 480

Options		Required to Specify
Surface Materials	Base <ul style="list-style-type: none"> • Paint price group 1 • Paint price group 2 	Specify paint color number. Specify paint color number.

Specification Information				
Dimensions			Style Number	
D	W	H		
18"	22"	24 ⁷ / ₈ "	TS4TST	
:	:	:	:	:

Await Occasional Table

DESIGN E00S

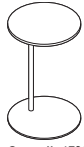

Overall: 15¾" Dia. 25"H

Standard Includes		Required to Specify
<ul style="list-style-type: none"> ▶ See <i>Coalesce Tables, Storage, and Accessories Specification Guide</i> for product details. 	<ul style="list-style-type: none"> • Freestanding table frame: 4142 Platinum Gloss • Top: 2730 Arctic White High-Pressure Laminate top with matching 3 mm edge band • Glass top: <ul style="list-style-type: none"> – ½" thick – Radiused edges 	<ul style="list-style-type: none"> 1 Style number 2 Glass color number for top, if selected ▶ See <i>Surface Materials</i> , page 480.

Specification Information

Style Number	Top Surface:		
	Laminate	Acid Etched 6511	Back-Painted Glass
46-T2	•	•	•

Round, High, Freestanding Table

46-T2	•	•	•
-------	---	---	---

Free Stand Occasional Table

DESIGN STEPHEN COPELAND

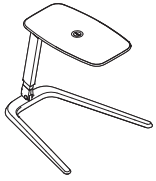

Tip: Worksurface height adjusts from 20"–27" and rotates 360°.

Tip: Free stand is 5" tall when folded/collapsed and weighs 11 lb.

Tip: Free stand can nest. In nested position each additional unit extends 5 1/4" beyond the previous unit.

Standard Includes	Required to Specify
-------------------	---------------------

- | | |
|---|--|
| <ul style="list-style-type: none"> ▶ See <i>Coalesse Tables, Storage, and Accessories Specification Guide</i> for product details. | <ul style="list-style-type: none"> • Height-adjustable, soft-touch: 4433 Black • Foldable/collapsible column: 4144 Black Gloss paint • Base: 4144 Black Gloss paint |
|---|--|

Style number

Specification Information		
Dimensions		Style
D	W	Number

22 1/4"	21 1/4"	COCFS
---------	---------	-------

Lagunitas Personal Table

DESIGN TOAN NGUYEN

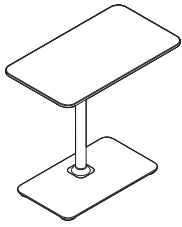

Standard Includes	Required to Specify
<ul style="list-style-type: none"> ▶ See <i>Coalesse Tables, Storage, and Accessories Specification Guide</i> for product details. • Table top: group 1 laminate with 3 mm flat plastic edge • Table base with column: group 1 paint • Four non-adjustable glides • Ships ready to assemble 	<ol style="list-style-type: none"> 1 Style number 2 Laminate color number for table top 3 Plastic edge color number for laminate table top, if selected 4 Paint color number base with column 5 Options, if selected (see below) <ul style="list-style-type: none"> ▶ See <i>Surface Materials</i>, page 480.

Options	Required to Specify
<p>Surface Materials</p> <ul style="list-style-type: none"> • Personal table base • Group 2 paint 	<p>Specify paint color number.</p>

Specification Information			
Style Number	Dimensions		
	D	W	H
COLAGTP	13"	24"	25"

Occasional Tables

Steelcase Flex Collection Freestanding Screens

Standard Includes	Required to Specify
-------------------	---------------------

- | | | |
|---|---|--|
| <ul style="list-style-type: none"> ▶ See <i>Flex Collection Specification Guide</i> for product details. | <ul style="list-style-type: none"> • Freestanding screen: fabric price group A or 1 • Magnetic edge: 6527 Merle | <ul style="list-style-type: none"> 1 Style number 2 Fabric color number for screen 3 Options, if selected (see below) ▶ See <i>Surface Materials</i>, page 480 |
|---|---|--|

Tip: When choosing contrasting fabrics, the angled screen becomes right-handed on the side of surface 1 and left-handed on the side of surface 2.

Tip: When choosing contrasting fabrics, surface 1 and surface 2 must stay within the same fabric family.

Tip: Fabric is applied in a warp horizontal direction. Due to the size of the screens, fabric is unable to be applied in a warp vertical direction.

Tip: The angled screen attaches magnetically only on its long side.

Tip: 71"H is only available on the rectangle freestanding screen.

Options		Required to Specify
---------	--	---------------------

Surface Materials	Surface 1 <ul style="list-style-type: none"> • Fabric price group 1 • Fabric price group A • Fabric price group 2 • Fabric price group 3 Surface 2 <ul style="list-style-type: none"> • Fabric price group 1 • Fabric price group A • Fabric price group 2 • Fabric price group 3 	Specify fabric color number. Specify fabric color number. Specify fabric color number. Specify fabric color number.
Size	<ul style="list-style-type: none"> • Modular 	Select modular.

Specification Information			
---------------------------	--	--	--

• Style Number	• Dimensions		
	• Height		
:	:	:	:
:	:	47"W	71"W
:	:	:	:
:	:	:	:

Rectangle			
-----------	--	--	--

FLXFSRQ	24"	•	•
:	30"	•	•
:	36"	•	•
:	:	:	:

Angled			
--------	--	--	--

FLXFSAG	47½"	•	N.A.
:	:	:	:

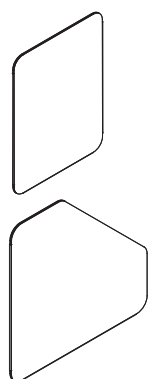

Steelcase Flex Collection Cart

Steelcase Flex
Collection Cart

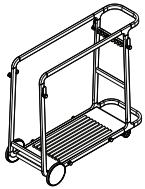

Standard Includes		Required to Specify
<ul style="list-style-type: none"> ▶ See <i>Flex Collections Specification Guide</i> for product details. 	<ul style="list-style-type: none"> • Frame: paint price group 1 • One perforated shelf: paint price group 1 	<ul style="list-style-type: none"> 1 Style number 2 Paint color number for frame 3 Plastic color number for wheels and casters 4 Plastic color number for board clips 5 Options, if selected (see below) ▶ See <i>Surface Materials</i>, page 480.
	<ul style="list-style-type: none"> • Wheels and casters: <ul style="list-style-type: none"> – 6053 Seagull – 6527 Merle • Board clips: <ul style="list-style-type: none"> – 6053 Seagull – 6527 Merle • Board organizer: 6527 Merle 	

Options		Required to Specify
Surface Materials	Frame <ul style="list-style-type: none"> • Paint price group 1 • Paint price group 2 	Specify paint color number. Specify paint color number.
	Shelf <ul style="list-style-type: none"> • Paint price group 1 • Paint price group 2 	

Specification Information			
Dimensions			Style Number
D	W	H	
:	:	:	:
:	:	:	:

Board Cart			
20"	46"	41 ³ / ₈ "	FLXCTBD
:	:	:	:

Screens

Steelcase Flex Collection Markerboard Solutions

Markerboards

Standard Includes	Required to Specify
<ul style="list-style-type: none"> ▶ See <i>Flex Collection Specification Guide</i> for product details. • Markerboard, double sided • Markerboard package, if selected: four double-sided markerboards 	Style number

Specification Information			
• Style Number	• Width	• Height	
.....47".....71".....

Markerboard			
FLXMB	36"	•	•
.....

Markerboard Package			
FLXMB4	36"	•	•
.....

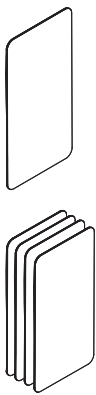

Stand

Standard Includes	Required to Specify
<ul style="list-style-type: none"> ▶ See <i>Flex Collection Specification Guide</i> for product details. • Stand worksurface: plywood • Stand base: <ul style="list-style-type: none"> – 6053 Seagull – 6527 Merle 	1 Style number 2 Plastic color number for base

Specification Information			
• Dimensions		• Style Number	
Dia.	H
.....16".....38".....	FLXSTAND	
.....

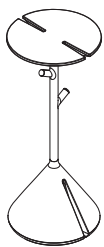

Tip: Plywood is a natural material and variations will occur in color, grain, and texture.

Sarto Privacy/Modesty Screens

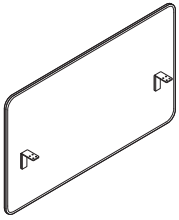

Tip: Sarto privacy/modesty screens can be attached to 3/4"–1 1/2" thick worksurface, including Ology, Migration SE, Elective Elements, universal tables, and universal panel-mount worksurfaces.

Tip: The screens weigh between 3.51 and 11.64 pounds. Take this into consideration when planning for use on height-adjustable worksurfaces. See understanding pages to calculate screen weight.

Tip: Worksurface type option adds a fourth worksurface bracket and repositions brackets to avoid worksurface scallops.

Tip: Side screen option changes standard brackets for smaller L-brackets and only mount flush to the side of the worksurface. Side screen option is only available on screens 36"W and narrower.

Standard Includes	Required to Specify
<ul style="list-style-type: none"> ▶ See <i>Height-Adjustable Desk Specification Guide</i> for product details. • Screen: fabric price group 1 • Brackets: 7360 Merle 	<ol style="list-style-type: none"> 1 Style number 2 Size option (see below under Required Selections) 3 Width (see below under Required Selections) 4 Height (see below under Required Selections) 5 Privacy height (see below under Required Selections) 6 Worksurface type (see below under Required Selections) 7 Screen type (see below under Required Selections) 8 Fabric color number for screen 9 Options, if selected (see below) <p>▶ See <i>Surface Materials</i>, page 480</p>

Required Selections		Required to Specify																																										
Size Option	<ul style="list-style-type: none"> • Modular • Parametric 	Specify <i>with modular</i> . Specify <i>with parametric</i> .																																										
Width	<table border="1"> <thead> <tr> <th style="background-color: #212121; color: white;">Modular</th> <th style="background-color: #212121; color: white;">Parametric</th> </tr> </thead> <tbody> <tr><td>• N.A.</td><td>23"W–28 15/16"W</td></tr> <tr><td>• 24"W</td><td>N.A.</td></tr> <tr><td>• 29"W</td><td>29"W</td></tr> <tr><td>• N.A.</td><td>29 1/16"W–36"W</td></tr> <tr><td>• 42"W</td><td>36 1/16"W–42"W</td></tr> <tr><td>• 46"W</td><td>N.A.</td></tr> <tr><td>• 48"W</td><td>42 1/16"W–48"W</td></tr> <tr><td>• 54"W</td><td>48 1/16"W–54"W</td></tr> <tr><td>• 58"W</td><td>N.A.</td></tr> <tr><td>• 60"W</td><td>54 1/16"W–60"W</td></tr> <tr><td>• 66"W</td><td>60 1/16"W–66"W</td></tr> <tr><td>• 70"W</td><td>66 1/16"W–70"W</td></tr> </tbody> </table>	Modular	Parametric	• N.A.	23"W–28 15/16"W	• 24"W	N.A.	• 29"W	29"W	• N.A.	29 1/16"W–36"W	• 42"W	36 1/16"W–42"W	• 46"W	N.A.	• 48"W	42 1/16"W–48"W	• 54"W	48 1/16"W–54"W	• 58"W	N.A.	• 60"W	54 1/16"W–60"W	• 66"W	60 1/16"W–66"W	• 70"W	66 1/16"W–70"W	Specify width. Specify width. Specify width. Specify width. Specify width. Specify width. Specify width. Specify width. Specify width. Specify width. Specify width.																
Modular	Parametric																																											
• N.A.	23"W–28 15/16"W																																											
• 24"W	N.A.																																											
• 29"W	29"W																																											
• N.A.	29 1/16"W–36"W																																											
• 42"W	36 1/16"W–42"W																																											
• 46"W	N.A.																																											
• 48"W	42 1/16"W–48"W																																											
• 54"W	48 1/16"W–54"W																																											
• 58"W	N.A.																																											
• 60"W	54 1/16"W–60"W																																											
• 66"W	60 1/16"W–66"W																																											
• 70"W	66 1/16"W–70"W																																											
Height	<table border="1"> <thead> <tr> <th style="background-color: #212121; color: white;">Modular</th> <th style="background-color: #212121; color: white;">Parametric</th> </tr> </thead> <tbody> <tr><td>• 24"H</td><td>24"H</td></tr> <tr><td>• 30"H</td><td>24 1/2"H–30"H</td></tr> </tbody> </table>	Modular	Parametric	• 24"H	24"H	• 30"H	24 1/2"H–30"H	Specify height. Specify height.																																				
Modular	Parametric																																											
• 24"H	24"H																																											
• 30"H	24 1/2"H–30"H																																											
Privacy Height	<table border="1"> <thead> <tr> <th style="background-color: #212121; color: white;">Screen Height</th> <th style="background-color: #212121; color: white;">Minimum Privacy Height</th> <th style="background-color: #212121; color: white;">Maximum Privacy Height</th> </tr> </thead> <tbody> <tr><td>• 24"H</td><td>9"H</td><td>16 1/2"H</td></tr> <tr><td>• 24 1/2"H</td><td>9 1/2"H</td><td>17"H</td></tr> <tr><td>• 25"H</td><td>10"H</td><td>17 1/2"H</td></tr> <tr><td>• 25 1/2"H</td><td>10 1/2"H</td><td>18"H</td></tr> <tr><td>• 26"H</td><td>11"H</td><td>18 1/2"H</td></tr> <tr><td>• 26 1/2"H</td><td>11 1/2"H</td><td>19"H</td></tr> <tr><td>• 27"H</td><td>12"H</td><td>19 1/2"H</td></tr> <tr><td>• 27 1/2"H</td><td>12 1/2"H</td><td>20"H</td></tr> <tr><td>• 28"H</td><td>13"H</td><td>20 1/2"H</td></tr> <tr><td>• 28 1/2"H</td><td>13 1/2"H</td><td>21"H</td></tr> <tr><td>• 29"H</td><td>14"H</td><td>21 1/2"H</td></tr> <tr><td>• 29 1/2"H</td><td>14 1/2"H</td><td>22"H</td></tr> <tr><td>• 30"H</td><td>15"H</td><td>22 1/2"H</td></tr> </tbody> </table>	Screen Height	Minimum Privacy Height	Maximum Privacy Height	• 24"H	9"H	16 1/2"H	• 24 1/2"H	9 1/2"H	17"H	• 25"H	10"H	17 1/2"H	• 25 1/2"H	10 1/2"H	18"H	• 26"H	11"H	18 1/2"H	• 26 1/2"H	11 1/2"H	19"H	• 27"H	12"H	19 1/2"H	• 27 1/2"H	12 1/2"H	20"H	• 28"H	13"H	20 1/2"H	• 28 1/2"H	13 1/2"H	21"H	• 29"H	14"H	21 1/2"H	• 29 1/2"H	14 1/2"H	22"H	• 30"H	15"H	22 1/2"H	Specify privacy height. Specify privacy height. Specify privacy height. Specify privacy height. Specify privacy height. Specify privacy height. Specify privacy height. Specify privacy height. Specify privacy height. Specify privacy height. Specify privacy height. Specify privacy height.
Screen Height	Minimum Privacy Height	Maximum Privacy Height																																										
• 24"H	9"H	16 1/2"H																																										
• 24 1/2"H	9 1/2"H	17"H																																										
• 25"H	10"H	17 1/2"H																																										
• 25 1/2"H	10 1/2"H	18"H																																										
• 26"H	11"H	18 1/2"H																																										
• 26 1/2"H	11 1/2"H	19"H																																										
• 27"H	12"H	19 1/2"H																																										
• 27 1/2"H	12 1/2"H	20"H																																										
• 28"H	13"H	20 1/2"H																																										
• 28 1/2"H	13 1/2"H	21"H																																										
• 29"H	14"H	21 1/2"H																																										
• 29 1/2"H	14 1/2"H	22"H																																										
• 30"H	15"H	22 1/2"H																																										
Worksurface Type	<p>For screens 60"W or greater</p> <ul style="list-style-type: none"> • Without scallop • With scallop 	Specify <i>without scallop</i> . Specify <i>with scallop</i> .																																										
Screen Type	<ul style="list-style-type: none"> • Rear screen • Side screen 	Specify <i>with rear screen</i> . Specify <i>with side screen</i> .																																										

Options		Required to Specify
Surface Materials	<ul style="list-style-type: none"> Fabric price group 2 Fabric price group 3 	Specify fabric color number. Specify fabric color number.

Tip: Fabric is applied horizontally on the screen.

Tip: Screen allows for 1½" cord drop or no cord drop when mounted to the rear of a worksurface. See understanding pages for product specific application guidelines.

Specification Information											
Style Number	Parametric Height	Modular width	24"W	29"W	N.A.	42"W	46"W or 48"W	54"W	58"W or 60"W	66"W	70"W
		Parametric width	23"W–28 ¹⁵ / ₁₆ "W	29"W	29 ¹ / ₁₆ "W–36"W	36 ¹ / ₁₆ "W–42"W	42 ¹ / ₁₆ "W–48"W	48 ¹ / ₁₆ "W–54"W	54 ¹ / ₁₆ "W–60"W	60 ¹ / ₁₆ "W–66"W	66 ¹ / ₁₆ "W–70"W

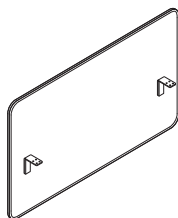

PSPM	24"	•	•	•	•	•	•	•	•	•	•
	24½"–30"	•	•	•	•	•	•	•	•	•	•
		:	:	:	:	:	:	:	:	:	:



Specification Information

Style Number	Parametric Height	Modular Width	•24"W	•30"W	•36"W	•42"W	•48"W	•54"W	•60"W	•66"W	•72"W	•78"W	•84"W	•90"W	•96"W
			Paramtric Width	•24 ¹ / ₁₆ "W	•30 ¹ / ₁₆ "W	•36 ¹ / ₁₆ "W	•42 ¹ / ₁₆ "W	•48 ¹ / ₁₆ "W	•54 ¹ / ₁₆ "W	•60 ¹ / ₁₆ "W	•66 ¹ / ₁₆ "W	•72 ¹ / ₁₆ "W	•78 ¹ / ₁₆ "W	•84 ¹ / ₁₆ "W	•90 ¹ / ₁₆ "W

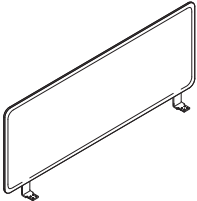

PSPS	13 ¹ / ₂ "	•	•	•	•	•	•	•	•	•	•	•	•	•	•
		14"-19 ¹ / ₂ "	•	•	•	•	•	•	•	•	•	•	•	•	•
	20"-24"	•	•	•	•	•	•	•	•	•	•	•	•	•	•
	24 ¹ / ₂ "-30"	•	•	•	•	•	•	•	•	•	•	•	•	•	•
	30 ¹ / ₂ "-35 ¹ / ₂ "	•	•	•	•	•	•	•	•	•	•	•	•	•	•



Sarto Curved Screens

L-Screen

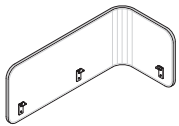

Tip: Sarto screens can be attached to 3/4" – 1 1/2" thick worksurfaces, including Ology, Migration SE, Elective Elements, Universal tables, and Universal panel-mount worksurfaces.

Tip: Screens weigh between 5.7 and 9 pounds. Take this into consideration when planning for use on height-adjustable worksurfaces.

Tip: Fabric is applied horizontally on the screen.

Tip: All Sarto curved screens have a 20" side leg depth.

Tip: Width refers to the distance from the corner of the worksurface to the edge of the screen when the screen is applied to the back of a worksurface.

Tip: Sarto curved screens sit flush against the work-surface. If 1" cord drop is needed, please reach out to Specials for alternative bracket.

Standard Includes	Required to Specify
<ul style="list-style-type: none"> See <i>Height-Adjustable Desk Specification Guide</i> for product details. Desk screen: fabric price group 1 Brackets: 7360 Merle 	<ol style="list-style-type: none"> Style number Size option (see below under Required Selections) Width (see below under Required Selections) Height (see below under Required Selections) Handedness (see below under Required Selections) Privacy height (see below under Required Selections) Fabric color number for screen Options, if selected (see below) <p>▶ See <i>Surface Materials</i>, page 480</p>

Required Selections		Required to Specify																																										
Size Options	<ul style="list-style-type: none"> Modular Parametric 	Specify with <i>modular</i> . Specify with <i>parametric</i> .																																										
Width	<table border="1"> <thead> <tr> <th>Modular</th> <th>Parametric</th> </tr> </thead> <tbody> <tr> <td>• 23"W</td> <td>23"W</td> </tr> <tr> <td>• 29"W</td> <td>23 1/16"W–29"W</td> </tr> <tr> <td>• 35"W</td> <td>29 1/16"W–35"W</td> </tr> <tr> <td>• 41"W</td> <td>35 1/16"W–41"W</td> </tr> <tr> <td>• 46"W</td> <td>41 1/16"W–46"W</td> </tr> </tbody> </table>	Modular	Parametric	• 23"W	23"W	• 29"W	23 1/16"W–29"W	• 35"W	29 1/16"W–35"W	• 41"W	35 1/16"W–41"W	• 46"W	41 1/16"W–46"W	Specify width. Specify width. Specify width. Specify width. Specify width.																														
Modular	Parametric																																											
• 23"W	23"W																																											
• 29"W	23 1/16"W–29"W																																											
• 35"W	29 1/16"W–35"W																																											
• 41"W	35 1/16"W–41"W																																											
• 46"W	41 1/16"W–46"W																																											
Height	<table border="1"> <thead> <tr> <th>Modular</th> <th>Parametric</th> </tr> </thead> <tbody> <tr> <td>• 17.909"H</td> <td></td> </tr> <tr> <td>• 18"H</td> <td>18"H</td> </tr> <tr> <td>• 24"H</td> <td>18 1/2"H–24"H</td> </tr> </tbody> </table>	Modular	Parametric	• 17.909"H		• 18"H	18"H	• 24"H	18 1/2"H–24"H	Specify height. Specify height. Specify height.																																		
Modular	Parametric																																											
• 17.909"H																																												
• 18"H	18"H																																											
• 24"H	18 1/2"H–24"H																																											
Handedness	<ul style="list-style-type: none"> Left-hand application Right-hand application 	Specify with <i>left-hand application</i> . Specify with <i>right-hand application</i> .																																										
Privacy Height	<table border="1"> <thead> <tr> <th>Screen Height</th> <th>Minimum Privacy Height</th> <th>Maximum Privacy Height</th> </tr> </thead> <tbody> <tr><td>• 18"H</td><td>7"H</td><td>10 1/2"H</td></tr> <tr><td>• 18 1/2"H</td><td>7"H</td><td>11"H</td></tr> <tr><td>• 19"H</td><td>7"H</td><td>11 1/2"H</td></tr> <tr><td>• 19 1/2"H</td><td>7"H</td><td>12"H</td></tr> <tr><td>• 20"H</td><td>7"H</td><td>12 1/2"H</td></tr> <tr><td>• 20 1/2"H</td><td>7"H</td><td>13"H</td></tr> <tr><td>• 21"H</td><td>7"H</td><td>13 1/2"H</td></tr> <tr><td>• 21 1/2"H</td><td>7"H</td><td>14"H</td></tr> <tr><td>• 22"H</td><td>7"H</td><td>14 1/2"H</td></tr> <tr><td>• 22 1/2"H</td><td>7 1/2"H</td><td>15"H</td></tr> <tr><td>• 23"H</td><td>8"H</td><td>15 1/2"H</td></tr> <tr><td>• 23 1/2"H</td><td>8 1/2"H</td><td>16"H</td></tr> <tr><td>• 24"H</td><td>9"H</td><td>16 1/2"H</td></tr> </tbody> </table>	Screen Height	Minimum Privacy Height	Maximum Privacy Height	• 18"H	7"H	10 1/2"H	• 18 1/2"H	7"H	11"H	• 19"H	7"H	11 1/2"H	• 19 1/2"H	7"H	12"H	• 20"H	7"H	12 1/2"H	• 20 1/2"H	7"H	13"H	• 21"H	7"H	13 1/2"H	• 21 1/2"H	7"H	14"H	• 22"H	7"H	14 1/2"H	• 22 1/2"H	7 1/2"H	15"H	• 23"H	8"H	15 1/2"H	• 23 1/2"H	8 1/2"H	16"H	• 24"H	9"H	16 1/2"H	Specify privacy height. Specify privacy height. Specify privacy height. Specify privacy height. Specify privacy height. Specify privacy height. Specify privacy height. Specify privacy height. Specify privacy height. Specify privacy height. Specify privacy height. Specify privacy height. Specify privacy height.
Screen Height	Minimum Privacy Height	Maximum Privacy Height																																										
• 18"H	7"H	10 1/2"H																																										
• 18 1/2"H	7"H	11"H																																										
• 19"H	7"H	11 1/2"H																																										
• 19 1/2"H	7"H	12"H																																										
• 20"H	7"H	12 1/2"H																																										
• 20 1/2"H	7"H	13"H																																										
• 21"H	7"H	13 1/2"H																																										
• 21 1/2"H	7"H	14"H																																										
• 22"H	7"H	14 1/2"H																																										
• 22 1/2"H	7 1/2"H	15"H																																										
• 23"H	8"H	15 1/2"H																																										
• 23 1/2"H	8 1/2"H	16"H																																										
• 24"H	9"H	16 1/2"H																																										

Options		Required to Specify
Surface Materials	<ul style="list-style-type: none"> Fabric price group 2 Fabric price group 3 	Specify fabric color number. Specify fabric color number.

Specification Information							
• Style Number	• Parametric Height	• Modular Width	• 23"W	• 29"W	• 35"W	• 41"W	• 46"W
		• Parametric Width					
			• 23"W	• 29"W	• 35"W	• 41"W	• 46"W
			• 23"W	• 23 1/16"W–29"W	• 29 1/16"W–35"W	• 35 1/16"W–41"W	• 41 1/16"W–46"W
PLSCRN	18"		•	•	•	•	•
	18 1/2"–24"		•	•	•	•	•

Sarto Curved Screens

Half-Desk Screen

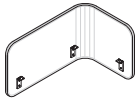

Tip: Sarto curved screens can be attached to 3/4" – 1 1/2" thick worksurfaces, including Ology, Migration SE, Elective Elements, Universal tables, and Universal panel-mount worksurfaces.

Tip: Screens weigh between 5.0 and 8 pounds. Take this into consideration when planning for use on height-adjustable worksurfaces.

Tip: Fabric is applied horizontally on the screen.

Tip: All Sarto curved screens have a 20" side leg depth.

Tip: Width refers to the distance from the corner of the worksurface to the edge of the screen when the screen is applied to the back of a worksurface.

Tip: Two half-desk screens (one LH and one RH) are required to wrap a full worksurface.

Tip: Sarto curved screens sit flush against the worksurface. If 1" cord drop is needed, please reach out to Specials for alternative bracket.

Standard Includes		Required to Specify
<ul style="list-style-type: none"> See <i>Height-Adjustable Desk Specification Guide</i> for product details. 	<ul style="list-style-type: none"> Curved desk screen: fabric price group 1 Brackets: 7360 Merle 	<ol style="list-style-type: none"> Style number Width (see below under Required Selections) Height (see below under Required Selections) Handedness (see below under Required Selections) Privacy height (see below under Required Selections) Fabric color number for screen Options, if selected (see below) <p>▶ See <i>Surface Materials</i>, page 480</p>

Required Selections		Required to Specify
Width	<ul style="list-style-type: none"> 23"W 29"W 35"W 	Specify with 23"W. Specify with 29"W. Specify with 35"W.
Height	Modular Parametric <ul style="list-style-type: none"> 17.909"H 18"H 18"H 24"H 18 1/2"H-24"H 	Specify height. Specify height. Specify height.
Handedness	<ul style="list-style-type: none"> Left-hand application Right-hand application 	Specify with left-hand application. Specify with right-hand application.

Privacy Height	Screen Height	Minimum Privacy Height	Maximum Privacy Height	
	18"H	7"H	10 1/2"H	Specify privacy height.
	18 1/2"H	7"H	11"H	Specify privacy height.
	19"H	7"H	11 1/2"H	Specify privacy height.
	19 1/2"H	7"H	12"H	Specify privacy height.
	20"H	7"H	12 1/2"H	Specify privacy height.
	20 1/2"H	7"H	13"H	Specify privacy height.
	21"H	7"H	13 1/2"H	Specify privacy height.
	21 1/2"H	7"H	14"H	Specify privacy height.
	22"H	7"H	14 1/2"H	Specify privacy height.
	22 1/2"H	7 1/2"H	15"H	Specify privacy height.
	23"H	8"H	15 1/2"H	Specify privacy height.
	23 1/2"H	8 1/2"H	16"H	Specify privacy height.
	24"H	9"H	16 1/2"H	Specify privacy height.

Options		Required to Specify
Surface Materials	<ul style="list-style-type: none"> Fabric price group 2 Fabric price group 3 	Specify fabric color number. Specify fabric color number.

Specification Information			
Style Number	23"W	29"W	35"W
	:	:	:
	:	:	:
	:	:	:
PHSCRN	•	•	•
	:	:	:
	:	:	:

Screens

TS Series Mobile Pedestals

With Steel Top

▶ See *Counterweight Requirements for Storage Products*, in the *Storage Specification Guide*.

Standard Includes	Required to Specify
<ul style="list-style-type: none"> ▶ See <i>Storage Specification Guide</i> for product details. • Pedestal: paint price group 1 • Pulls: metal • Lock face ring with plastic plug to accommodate lock cylinder: 9201 Polished Chrome • Steel ball-bearing suspensions on box and file drawers • 1½"-diameter, front-locking, hard casters 	<ul style="list-style-type: none"> 1 Style number 2 Paint color number for pedestal 3 Pull (see below under required selections) 4 Options, if selected (see below) ▶ See <i>Surface Materials</i>, page 480 <i>Tip: Remember to specify lock cylinder and key.</i> ▶ <i>Lock Cylinders</i>, page 441.

Required Selections		
Pulls		
		
Contemporary	Handle	Ledge

Options	Required to Specify
Surface Materials <ul style="list-style-type: none"> • Paint price group 2 	Specify paint color number.
Pulls <ul style="list-style-type: none"> • Contemporary pulls • Handle pulls • Ledge pulls: 7207 Black • Ledge pulls: 4799 Platinum Metallic 	Specify with <i>contemporary pulls</i> . Specify with <i>handle pulls</i> . Specify with <i>7207 Black ledge pulls</i> . Specify with <i>4799 Platinum Metallic ledge pulls</i> .
Trim Strip Handle Pull <ul style="list-style-type: none"> • Extra handle pull on trim strip of mobile pedestals only 	Specify with <i>extra handle pull on trim strip</i> .

Specification Information				
Dimensions			Counterweight Package	Style Number
D	W	H		
19"	15¼"	21"	N.A.	TS2PBF19M
22"	15¼"	21"	N.A.	TS2PBF22M

Box/File				
19"	15¼"	21"	N.A.	TS2PBF19M
22"	15¼"	21"	N.A.	TS2PBF22M

File/File				
22"	15¼"	26⅝"	Included	TS2PFF22M

Box/Box/File				
22"	15¼"	26⅝"	Included	TS2PBBF22M



TS Series Mobile Pedestals

With Seat Cushion

▶ See *Counterweight Requirements for Storage Products*, in the *Storage Specification Guide*.

Tip: For cushion top: Fabric patterns with a linear design will always be applied from the front to back of the unit (depth of the unit).

Standard Includes	Required to Specify
<ul style="list-style-type: none"> ▶ See <i>Storage Specification Guide</i> for product details. • Pedestal: paint price group 1 • Seat cushion: fabric price group 1 • Pulls: metal • Lock face ring with plastic plug to accommodate lock cylinder: 9201 Polished Chrome • Handle on pedestal with seat cushion and handle, if selected: 0835 Black • Steel ball-bearing suspensions on box and file drawers • 1½"-diameter front-locking, hard casters 	<ol style="list-style-type: none"> 1 Style number 2 Fabric color number for seat cushion 3 Paint color number for pedestal 4 Pull (see below under Required Selections) 5 Options, if selected (see below) <ul style="list-style-type: none"> ▶ See <i>Surface Materials</i>, page 480. <i>Tip: Remember to specify lock cylinder and key.</i> ▶ <i>Lock Cylinders</i>, page 441.

Required Selections

Pulls

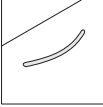
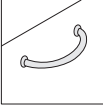
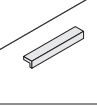
		
Contemporary	Handle	Ledge

Options	Required to Specify
<p>Surface Materials</p> <ul style="list-style-type: none"> • Paint price group 2 <p>Seat cushion</p> <ul style="list-style-type: none"> • Fabric price group 2 • Fabric price group 3 • Fabric price group 5 • Fabric price group 6 	<p>Specify paint color number.</p> <p>Specify fabric color number. Specify fabric color number. Specify fabric color number. Specify fabric color number.</p>
<p>Pulls</p> <ul style="list-style-type: none"> • Contemporary pulls • Handle pulls • Ledge pulls: 7207 Black • Ledge pulls: 4799 Platinum Metallic 	<p>Specify with <i>contemporary pulls</i>. Specify with <i>handle pulls</i>. Specify with <i>7207 Black ledge pulls</i>. Specify with <i>4799 Platinum Metallic ledge pulls</i>.</p>
<p>Trim Strip Handle Pull</p> <ul style="list-style-type: none"> • Extra handle pull on trim strip of mobile pedestal with seat cushion only 	<p>Specify with <i>extra handle pull on trim strip</i>.</p>

Specification Information

• Dimensions			• Counterweight	• Style
D	W	H	Package	Number
..
..

Mobile Pedestal with Seat Cushion

Box/File				
22¼"	15¼"	22¾"	N.A.	TS2PBF22MC
..

Mobile Pedestal with Seat Cushion and Handle

Box/File				
22½"	16¼"	22¾"	N.A.	TS2PBF22MCH
..



Storage

TS Series Mobile Pedestal Accessories

Box Drawer Divider



Standard Includes	Required to Specify
<ul style="list-style-type: none"> Box drawer divider: black plastic 	Style number

Specification Information			
• Dimensions			• Style
D	W	H	Number
3/4"	12 3/4"	4 3/8"	TS2PBDD
·	·	·	·

File Drawer Divider

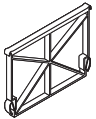

Tip: File drawer divider is required to file legal-sized files in pedestal file drawers.

Standard Includes	Required to Specify
<ul style="list-style-type: none"> File drawer divider: black plastic 	Style number

Specification Information			
• Dimensions			• Style
D	W	H	Number
3/4"	12 3/4"	9 3/16"	TS2PFDD
·	·	·	·

Pencil Tray

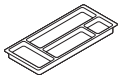

Standard Includes	Required to Specify
<ul style="list-style-type: none"> Pencil tray: black plastic 	Style number

Specification Information			
• Dimensions			• Style
D	W	H	Number
5 9/16"	12 7/8"	1"	TS2PPT
·	·	·	·

Universal Fixed Pedestals

With Flush Steel or Proud Steel Fronts

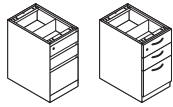

Tip: Counterweight packages are required to ensure product stability and are ordered as an option or separately. Product specification pages indicate the correct counterweight package for each style number and any exceptions where counterweights are not required.

▶ See Counterweight Requirements for Storage Products, in the Storage Specification Guide.

Standard Includes	Required to Specify
<ul style="list-style-type: none"> ▶ See <i>Storage Specification Guide</i> for product details. • Pedestal: paint price group 1 • Removable drawer fronts: paint to match pedestal • Integral pulls on units with flush steel fronts • Pulls: metal • Full drawer interiors: black only <ul style="list-style-type: none"> – One pencil tray and two box drawer dividers per box/file • Lock, keyed random: 9201 Polished Chrome • Mounting hardware • Four adjustable leveling glides 	<ol style="list-style-type: none"> 1 Style number with appropriate front style in the space provided <ul style="list-style-type: none"> F Flush steel front P Proud steel front 2 Paint color number for pedestal 3 Pull (see below under Required Selections) 4 Metal color number for pulls, if proud steel front selected 5 Options, if selected (see below) <ul style="list-style-type: none"> ▶ See <i>Surface Materials</i>, page 480.

Required Selections

Pulls

Contemporary	Handle	Jazz	Bar

Options

Options	Required to Specify
Surface Materials <ul style="list-style-type: none"> • Paint price group 1 • Paint price group 2 	Specify paint color number. Specify paint color number.
Pulls <ul style="list-style-type: none"> • Proud steel fronts <ul style="list-style-type: none"> • Contemporary • Handle • Jazz • Bar 	Specify with <i>contemporary pull</i> . Specify with <i>handle pull</i> . Specify with <i>jazz pull</i> . Specify with <i>bar pull</i> .
Drawer Accessories <ul style="list-style-type: none"> • Rails <ul style="list-style-type: none"> • Two side-to-side hanging rails per file drawer 	Specify with <i>rails</i> .
Lock and Keying <ul style="list-style-type: none"> • Lock <ul style="list-style-type: none"> • Ember Chrome • Keying <ul style="list-style-type: none"> • Factory- and field-installed keying 	Specify with <i>9250 Ember Chrome lock</i> . ▶ Page 441

Specification Information

Dimensions		W	H	Counter-weight Package	Style Number	Flush Steel Front	Proud Steel Front
D	Front						
						F	P

Tip: Your specification is not complete until you add a **F** or **P** to the style number to define the front style (for example, **RPF1827A** becomes **RPF1827AP** for proud steel front).

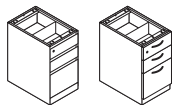

Tip: Use 27"H pedestals to align with Universal Storage with 3" base. 27"H pedestals support worksurfaces at 28½"H.

Tip: Only 22½"D, 23½"D, 28½"D, and 29½"D pedestals can accommodate legal-size filing.

27"H Fixed Pedestals with 3" Base

Two Box Drawers and One File Drawer

17½"	18¾"	15"	27"	RAACW15	RPF1827A	•	•
22½"	23½"	15"	27"	RAACW15	RPF2427A	•	•
28½"	29½"	15"	27"	RAACW15	RPF3027A	•	•

Two File Drawers

17½"	18¾"	15"	27"	RAACW15	RPF1827B	•	•
22½"	23½"	15"	27"	RAACW15	RPF2427B	•	•
28½"	29½"	15"	27"	RAACW15	RPF3027B	•	•

Universal Pedestal Fillers, Counterweights, and Interlock

Universal Pedestal Fillers for 27"H Fixed Pedestals with Flush and Proud Fronts



Standard Includes	Required to Specify
-------------------	---------------------

- | | | |
|---|---|--|
| <ul style="list-style-type: none"> ▶ See <i>Storage Specification Guide</i> for product details. | <ul style="list-style-type: none"> • Filler: all paint price groups • Installation hardware | <ul style="list-style-type: none"> 1 Style number 2 Paint color number for filler ▶ See <i>Surface Materials</i>, page 480. |
|---|---|--|

Specification Information		
---------------------------	--	--

• Dimensions		• Application	• Style Number
D	H		
Flush Steel Front	Proud Steel Front		

Pedestal Fillers for 27"H Fixed Pedestals with Flush Steel Fronts

13/8"	N.A.	27"	Answer and Kick Panels	RPXF TAKFP
13/8"	N.A.	27"	Montage Frames	RPXF MONFP

Pedestal Fillers for 27"H Fixed Pedestals with Proud Fronts

N.A.	1/2"	27"	Answer and Kick Panels	RPXF TAKPP
N.A.	1/2"	27"	Montage Frames	RPXF MONPP

Universal Pedestal Counterweight

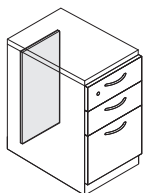

Standard Includes	Required to Specify
-------------------	---------------------

- | | | |
|---|---|--|
| <ul style="list-style-type: none"> ▶ See <i>Storage Specification Guide</i> for product details. | <ul style="list-style-type: none"> • Pedestal counterweight: black | <ul style="list-style-type: none"> Style number |
|---|---|--|

Specification Information

• Style Number
RAACW15

Universal Pedestal Interlock

For Use with 27"H Fixed Pedestals



Standard Includes	Required to Specify
▶ See <i>Storage Specification Guide</i> for product details. <ul style="list-style-type: none">• Interlock	Style number

Specification Information

• **Style Number**

RPXFTINT

Storage

Universal Fixed to Freestanding Pedestal Conversion Kits

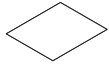

Tip: Flush and proud front pedestals require different conversion kits. Be sure to order the correct style number for your application.

Standard Includes		Required to Specify
▶ See <i>Storage Specification Guide</i> for product details.	<ul style="list-style-type: none"> • 1/8"H steel top: all paint price groups • Counterweight package • Installation hardware 	1 Style number 2 Paint color number for top ▶ See <i>Surface Materials</i> , page 480.

Specification Information		
Dimensions		Style
D	H	Number

For 27"H Proud Steel, Laminate, or Wood Front Pedestals

18 ³ / ₈ "	27"	RPXCK22718P
23 ¹ / ₂ "	27"	RPXCK22724P
29 ¹ / ₂ "	27"	RPXCK22730P
:	:	:

For 27"H Flush Steel Front Pedestals

17 ¹ / ₂ "	27"	RPXCK22718F
22 ⁵ / ₈ "	27"	RPXCK22724F
28 ⁵ / ₈ "	27"	RPXCK22730F
:	:	:

Pencil Tray

For Use in Pedestals and Universal Towers

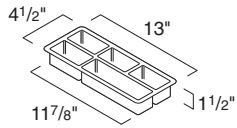

Tip: Pedestals with box drawers include one pencil tray per pedestal.

Standard Includes	Required to Specify
-------------------	---------------------

- | | |
|---|---|
| <ul style="list-style-type: none"> ▶ See <i>Storage Specification Guide</i> for product details. | <ul style="list-style-type: none"> • Pencil tray: black only |
|---|---|

Style number

Specification Information

• **Style Number**

RPXDPT

Storage

Universal Mobile Pedestals

With Flush Steel or Proud Steel Fronts

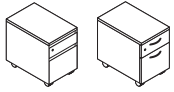

Tip: 1/8"H steel top is non-structural.

Tip: Counterweight packages for mobile pedestals are required to ensure product stability and are included.

▶ See Counterweight Requirements for Storage Products, in the Storage Specification Guide.

Standard Includes	Required to Specify
<p>▶ See <i>Storage Specification Guide</i> for product details.</p> <ul style="list-style-type: none"> • Pedestal: paint price group 1 • 1/8"H steel top: paint to match pedestal • Removable drawer fronts: paint to match pedestal • Integral pulls on units with flush steel fronts • Pulls: metal • Full drawer interiors: black only <ul style="list-style-type: none"> – One pencil tray per box/file or box/box/file and box drawer dividers • Lock, keyed random: 9201 Polished Chrome • Four hard-composition, non-locking casters: black only • Counterweight package 	<ol style="list-style-type: none"> 1 Style number with appropriate front style in the space provided <ul style="list-style-type: none"> F Flush steel front P Proud steel front 2 Paint color number for pedestal 3 Pull (see below under required selections) 4 Metal color number for pulls, if proud steel front selected 5 Options, if selected (see below) <p>▶ See <i>Surface Materials</i>, page 480.</p>

Required Selections

Pulls

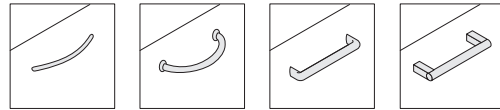

Contemporary

Handle

Jazz

Bar

Options	Required to Specify
<p>Surface Materials</p> <ul style="list-style-type: none"> • Paint price group 1 • Paint price group 2 	<p>Specify paint color number. Specify paint color number.</p>
<p>Tops</p> <ul style="list-style-type: none"> • 1"H square edge steel top 	<p>Specify with <i>steel square top</i>.</p>
<p>Pulls</p> <p>Proud steel fronts</p> <ul style="list-style-type: none"> • Contemporary • Handle • Jazz • Bar 	<p>Specify with <i>contemporary pull</i>. Specify with <i>handle pull</i>. Specify with <i>jazz pull</i>. Specify with <i>bar pull</i>.</p>
<p>Drawer Accessories</p> <p>Rails</p> <ul style="list-style-type: none"> • Two side-to-side hanging rails per file drawer 	<p>Specify with <i>rails</i>.</p>
<p>Lock and Keying</p> <p>Lock</p> <ul style="list-style-type: none"> • Ember Chrome <p>Individual locking drawers</p> <ul style="list-style-type: none"> • File/file pedestals only <p>Keying</p> <ul style="list-style-type: none"> • Factory- and field-installed keying 	<p>Specify with <i>9250 Ember Chrome lock</i>.</p> <p>Specify with <i>individual drawer lock</i>.</p> <p>▶ Page 441</p>

Tip: Your specification is not complete until you add a **F** or **P** to the style number to define the front style (for example, **RPM1821C** becomes **RPM1821CP** for proud steel front).

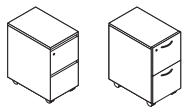
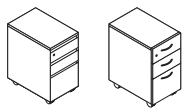
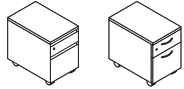

Specification Information

Dimensions		W	H	Counter-weight Package	Style Number	Flush Steel Front	Proud Steel Front
D	Front						
						F	P

Box/File

17½"	18¾"	15"	21"	Included	RPM1821C _	•	•
22⅝"	23½"	15"	21"	Included	RPM2421C _	•	•

Box/Box/File

17½"	18¾"	15"	27"	Included	RPM21827A _	•	•
22⅝"	23½"	15"	27"	Included	RPM22427A _	•	•

File/File

17½"	18¾"	15"	27"	Included	RPM21827B _	•	•
22⅝"	23½"	15"	27"	Included	RPM22427B _	•	•

Universal Over the Case Bins with Flat Fronts

For Use with Answer and Kick

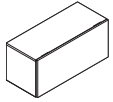

Standard Includes		Required to Specify
<ul style="list-style-type: none"> ▶ See <i>Storage Specification Guide</i> for product details. 	<ul style="list-style-type: none"> Overhead bin with lift-up door: paint price group 1 Recess beneath unit to accommodate shelf light Shelf backstop On-module attachment brackets with safety catch: black paint only Lock, keyed random: 9201 Polished Chrome 	<ul style="list-style-type: none"> 1 Style number 2 Paint color number for overhead bin 3 Options, if selected (see below) ▶ See <i>Surface Materials</i>, page 480.

Options		Required to Specify
Surface Materials	Overhead bin with one door	Specify paint color number.
	<ul style="list-style-type: none"> Paint price group 1 Paint price group 2 	Specify paint color number.
Brackets	Overhead bin with two doors	Specify paint color number.
	<ul style="list-style-type: none"> Paint price group 1 Paint price group 2 	Specify paint color number.
Door Mechanism	Upmount brackets	Specify with upmount kit.
	<ul style="list-style-type: none"> Upmount kit 	
Shelf Accessories	No brackets	Specify omit brackets.
	<ul style="list-style-type: none"> Omit brackets 	
Lock and Keying	Assist mechanism for standard door or omit insert	Specify with assist mechanism.
	<ul style="list-style-type: none"> Assist mechanism for standard door or omit insert 	
Lock and Keying	Four dividers: white plastic	Specify with dividers.
	<ul style="list-style-type: none"> Four dividers: white plastic 	
Lock and Keying	Lock	Specify with no lock.
	<ul style="list-style-type: none"> No lock Ember Chrome 	Specify with 9250 Ember Chrome lock.
Lock and Keying	Keying	▶ Page 441
	<ul style="list-style-type: none"> Factory- and field-installed keying 	

Tip: Upmount brackets include steel back to enclose storage bin.

Tip: Overhead storage bins and shelves with a "TAK" suffix can be used with Privacy Wall as well.

▶ See *Architectural Solutions Specification Guide* for attachment information.

Tip: Units specified with no lock will still have a visible slot in the shelf where locking components would be.

Specification Information				
Dimensions			Number of Doors	Style Number
D	W	H		
15¾"	24"	16¼"	1	RBB24QTAK
15¾"	30"	16¼"	1	RBB30QTAK
15¾"	36"	16¼"	1	RBB36QTAK
15¾"	42"	16¼"	1	RBB42QTAK
15¾"	48"	16¼"	1	RBB48QTAK
15¾"	60"	16¼"	2	RBB60QTAK
15¾"	66"	16¼"	2	RBB66QTAK
15¾"	72"	16¼"	2	RBB72QTAK

Bins with Flat Fronts for Use with Answer and Kick

15¾"	24"	16¼"	1	RBB24QTAK
15¾"	30"	16¼"	1	RBB30QTAK
15¾"	36"	16¼"	1	RBB36QTAK
15¾"	42"	16¼"	1	RBB42QTAK
15¾"	48"	16¼"	1	RBB48QTAK
15¾"	60"	16¼"	2	RBB60QTAK
15¾"	66"	16¼"	2	RBB66QTAK
15¾"	72"	16¼"	2	RBB72QTAK

Tip: Overhead storage bins and shelves with a "TAK" suffix can be used with Privacy Wall as well.

▶ See *Architectural Solutions Specification Guide* for attachment information.

Universal In the Case Bins with Steel Flat Fronts

For Use with Answer and Kick

Universal In the Case Bins
with Steel Flat Fronts

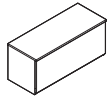

Standard Includes		Required to Specify
<ul style="list-style-type: none"> ▶ See <i>Storage Specification Guide</i> for product details. 	<ul style="list-style-type: none"> Overhead bin with lift-up door: paint price group 1 Recess beneath unit to accommodate shelf light Shelf backstop On-module attachment brackets with safety catch: black paint only Lock, keyed random: 9201 Polished Chrome 	<ul style="list-style-type: none"> 1 Style number 2 Paint color number for bin 3 Options, if selected (see below) ▶ See <i>Surface Materials</i>, page 480.

Options		Required to Specify
Surface Materials	Overhead bin with one steel door	Specify paint color number. Specify paint color number.
	Overhead bin with two steel doors	Specify paint color number. Specify paint color number.
Brackets	Upmount brackets	Specify <i>with upmount kit</i> .
	No brackets	Specify <i>omit brackets</i> .
Door Mechanism	Assist mechanism for standard door or omit insert	Specify <i>with assist mechanism</i> .
Shelf Accessories	Four dividers: white plastic	Specify <i>with dividers</i> .
Lock and Keying	Lock	Specify <i>with no lock</i> . Specify <i>with 9250 Ember Chrome lock</i> .
	Keying	Factory- and field-installed keying ▶ Page 441

Tip: Upmount brackets include steel back to enclose storage bin.

Tip: Units specified with no lock will still have a visible slot in the shelf where locking components would be.

Specification Information				
Dimensions			Number of Doors	Style Number
D	W	H		

Bins with Steel Flat Fronts for Use with Answer and Kick

15¾"	24"	16¼"	1	RBB24TAK
15¾"	30"	16¼"	1	RBB30TAK
15¾"	36"	16¼"	1	RBB36TAK
15¾"	42"	16¼"	1	RBB42TAK
15¾"	48"	16¼"	1	RBB48TAK
15¾"	60"	16¼"	2	RBB60TAK
15¾"	66"	16¼"	2	RBB66TAK
15¾"	72"	16¼"	2	RBB72TAK

Tip: Overhead storage bins and shelves with a "TAK" suffix can be used with Privacy Wall as well.

▶ See *Architectural Solutions Specification Guide* for attachment information.

Storage

Universal Shelves

Universal Shelves

For Use with Answer and Kick

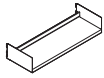

Standard Includes	Required to Specify
<ul style="list-style-type: none"> ▶ See <i>Storage Specification Guide</i> for product details. • Shelf: paint price group 1 • Recess beneath unit to accommodate shelf light • Shelf backstop • On-module attachment hooks with safety catch 	<ul style="list-style-type: none"> 1 Style number 2 Paint color number for shelf 3 Options, if selected (see below) ▶ See <i>Surface Materials</i>, page 480.

Options	Required to Specify
Surface Materials <ul style="list-style-type: none"> • Paint price group 1 • Paint price group 2 	<ul style="list-style-type: none"> Specify paint color number. Specify paint color number.

Specification Information			
• Dimensions			• Style
D	W	H	Number

For Use with Answer and Kick			
14¾"	24"	7½"	RSH24TAK
14¾"	30"	7½"	RSH30TAK
14¾"	36"	7½"	RSH36TAK
14¾"	42"	7½"	RSH42TAK
14¾"	48"	7½"	RSH48TAK
14¾"	60"	7½"	RSH60TAK
14¾"	72"	7½"	RSH72TAK

Tip: Overhead storage bins and shelves with a "TAK" suffix can be used with Privacy Wall as well.

▶ See *Architectural Solutions Specification Guide* for attachment information.

Universal Personal Shelves

For Use with Answer and Kick

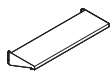

Tip: Overhead storage bins and shelves with a "TAK" suffix can be used with Privacy Wall as well.
 ▶ See *Architectural Solutions Specification Guide* for attachment information.

Standard Includes		Required to Specify
-------------------	--	---------------------

- | | | |
|---|---|---|
| ▶ See <i>Storage Specification Guide</i> for product details. | <ul style="list-style-type: none"> Personal shelf: paint price group 1 Recess beneath unit to accommodate shelf light On-module attachment hooks | 1 Style number
2 Paint color number for personal shelf
3 Options, if selected (see below)
▶ See <i>Surface Materials</i> , page 480. |
|---|---|---|

Options	Required to Specify
---------	---------------------

- | | |
|---|--|
| Surface Materials <ul style="list-style-type: none"> Paint price group 1 Paint price group 2 | Specify paint color number.
Specify paint color number. |
|---|--|

Specification Information

Dimensions		Style
D	W	Number
:	:	:
:	:	:

For Use with Answer and Kick

13 ¹ / ₁₆ "	24"	RDS24TAK
13 ¹ / ₁₆ "	30"	RDS30TAK
13 ¹ / ₁₆ "	36"	RDS36TAK
13 ¹ / ₁₆ "	42"	RDS42TAK
13 ¹ / ₁₆ "	48"	RDS48TAK
:	:	:

Accessories For Universal Bins and Universal Shelves

Horizontal Wall Attachment Brackets

For Use with Universal Sliding Door, Universal Over the Case, and Universal In the Case Bins

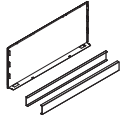

Standard Includes		Required to Specify
<ul style="list-style-type: none"> ▶ See <i>Storage Specification Guide</i> for product details. 	<ul style="list-style-type: none"> • Brackets: paint price group 1 • Steel back to enclose storage bin: paint price group 1 	<ul style="list-style-type: none"> 1 Style number 2 Paint color number for brackets and back 3 Options, if selected (see below) ▶ See <i>Surface Materials</i>, page 480.

Options		Required to Specify
Surface Materials	<ul style="list-style-type: none"> • Paint price group 1 • Paint price group 2 	<ul style="list-style-type: none"> Specify paint color number. Specify paint color number.

Specification Information	
Width	Style Number
24"	RBKHWM24
30"	RBKHWM30
36"	RBKHWM36
42"	RBKHWM42
48"	RBKHWM48
60"	RBKHWM60
72"	RBKHWM72
:	:

Dividers

For Use with Universal Sliding Door, Universal Over the Case, Universal In the Case, and Universal Shelves



Standard Includes		Required to Specify
<ul style="list-style-type: none"> ▶ See <i>Storage Specification Guide</i> for product details. 	<ul style="list-style-type: none"> • Package of four dividers: white plastic only 	<ul style="list-style-type: none"> Style number

Specification Information	
Style Number	
RDIV	
:	:

Universal Vertical Off-Module Bracket

For Use with Universal Sliding Door, Universal Over the Case, and Universal In the Case Bins



Tip: For two-sided, off-module application, order two vertical off-module brackets.

Tip: Vertical off-module brackets are used with panels which have vertical slot patterns including Answer and Kick.

Tip: For Montage, vertical off-module brackets can be used with 30"W to 60"W bins only.

Standard Includes	Required to Specify
<ul style="list-style-type: none"> ▶ See <i>Storage Specification Guide</i> for product details. • Vertical off-module bracket with safety catch: black paint only 	Style number

Specification Information

• **Style Number**

RBKVOFM

Standard Overhead Upmount Packages

For Use on Answer and Kick

For Use with Universal Sliding Door, Universal Over the Case, and Universal In the Case Bins



Standard Includes	Required to Specify
<ul style="list-style-type: none"> ▶ See <i>Storage Specification Guide</i> for product details. • Pair of steel upmount brackets: paint price group 1 • Steel back to enclose storage bin 	<ul style="list-style-type: none"> 1 Style number 2 Paint color number for brackets and back 3 Options, if selected (see below) ▶ See <i>Surface Materials</i>, page 480.

Options	Required to Specify
<ul style="list-style-type: none"> • Paint price group 1 • Paint price group 2 	<ul style="list-style-type: none"> Specify paint color number. Specify paint color number.

Specification Information

• **Width**

• **Style Number**

For Use with Answer and Kick

24"	RUK24TAK
30"	RUK30TAK
36"	RUK36TAK
42"	RUK42TAK
48"	RUK48TAK
60"	RUK60TAK
72"	RUK72TAK
:	:

Storage

Wall Channels for TS Series Bins, Universal Bins, and Universal Shelves

For Use with Overhead Storage Products



Standard Includes		Required to Specify
▶ See <i>Storage Specification Guide</i> for product details.	• Pair of channels: paint	1 Style number 2 Paint color number for channels ▶ See <i>Surface Materials</i> , page 480.
Specification Information		
• Height	• Style Number	
66"	TS7BSWHC	
⋮	⋮	

Wall Channel Horizontal Braces

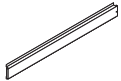

Standard Includes		Required to Specify
▶ See <i>Storage Specification Guide</i> for product details.	• Brace: paint	1 Style number 2 Paint color number for horizontal brace ▶ See <i>Surface Materials</i> , page 480.
Specification Information		
• Width	• Style Number	
42"	TS742HB	
48"	TS748HB	
60"	TS760HB	
72"	TS772HB	
⋮	⋮	

Bookends

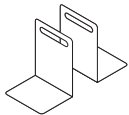

Standard Includes		Required to Specify
▶ See <i>Storage Specification Guide</i> for product details.	• Package of two bookends: 6695 Midnight only	Style number
Specification Information		
• Style Number	• Quantity	
KDIV02	2	
⋮	⋮	

Vertical Wire Manager

For Use on Answer and Kick Panels



Tip: Wire manager can be cut in the field to the specific length needed.

Standard Includes	Required to Specify
-------------------	---------------------

<ul style="list-style-type: none"> ▶ See <i>Storage Specification Guide</i> for product details. 	<ul style="list-style-type: none"> • Vertical wire manager: plastic
	<ul style="list-style-type: none"> 1 Style number 2 Plastic color number: <ul style="list-style-type: none"> 6000 Black 6009 Arctic White 6249 Platinum Solid 6654 Sand 6697 Fog

Specification Information	
• Height	• Style Number

<ul style="list-style-type: none"> 48" 	<ul style="list-style-type: none"> TS7PVWM
---	--



Universal One-High, 1.5-High, and Two Drawer Lateral Files

With Flush Steel, Proud Steel, or Open Fronts

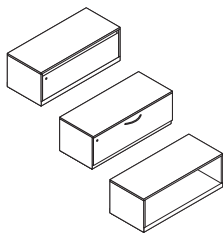

Tip: Service part Y30291SR, (paintable black plug), can be ordered to cover the glide adjustment holes in the front of the lateral file.

Standard Includes		Required to Specify
<ul style="list-style-type: none"> ▶ See <i>Storage Specification Guide</i> for product details. 	<ul style="list-style-type: none"> Lateral file: paint price group 1 1"H top on units with flush steel or proud steel fronts: paint to match file Base (see below under required selections) Pulls: metal Integral pulls on units with flush steel fronts Central lock, keyed random: 9201 Polished Chrome One label holder per drawer: clear plastic Drawer body: black only Drawer suspensions: black only One hanging folder bar per drawer on 18"D units Two rails per drawer on 24"D units Four adjustable leveling glides Ganging hardware Counterweight package, if selected 	<ol style="list-style-type: none"> Style number with appropriate front style in the space provided <ul style="list-style-type: none"> F Flush steel front P Proud steel front Paint color number for file Base (see below under required selections) Pull (see below under required selections) Metal color number for pulls, if proud steel front selected Options, if selected (see below) <ul style="list-style-type: none"> ▶ See <i>Surface Materials</i>, page 480.

Required Selections		Required to Specify
Bases <ul style="list-style-type: none"> Universal 3" base c:scape glide base 		Specify with <i>Universal 3" base</i> , painted to match tower. Specify with <i>c:scape glide base</i> , 4799 Platinum Metallic only.

Pulls

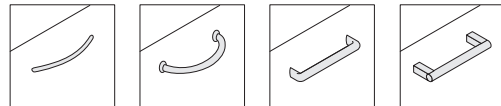

Contemporary Handle Jazz Bar

Options		Required to Specify
Surface Materials <ul style="list-style-type: none"> Paint price group 1 Paint price group 2 		Specify paint color number. Specify paint color number.
Tops for Flush Steel Front and Proud Steel Front	Security top <ul style="list-style-type: none"> For use on 28"H lateral files only 	Specify with <i>security top</i> .
	No top <ul style="list-style-type: none"> For use with a cushion top or beneath a common top 	Specify with <i>no top</i> .
	Laminate top <ul style="list-style-type: none"> Square edge laminate price group 1 top Square edge laminate price group 3 top 	Specify with <i>laminate top</i> and indicate laminate color number for top and plastic color number for edges. Specify with <i>laminate top</i> and indicate laminate color number for top and plastic color number for edges.

Tip: Security top reduces overall height by approximately 1".

Tip: Laminate tops are 3/16" taller than other tops and will add 3/16" to overall case height.

▶ Options, continued on next page

► Options, continued from previous page

	Options	Required to Specify
Drawer Interiors	• HF bar for use on 24"D units only	Specify with HF bar.
	• Divider package • Rails for use on 18"D units only	Specify with divider package. Specify with rails.
Pulls	Proud steel fronts	
	• Contemporary • Handle • Jazz • Bar	Specify with contemporary pull. Specify with handle pull. Specify with jazz pull. Specify with bar pull.
Counterweights	One-High and 1.5-High lateral files with Universal 3" base	
	• Package 30	Specify with counterweight.
	• Package 36	Specify with counterweight.
	• Package 42	Specify with counterweight.
	• Package D	Specify with counterweight.
	• Package E	Specify with counterweight.
• Package F	Specify with counterweight.	
	One-High and 1.5-High lateral files with c:scape glide base	
	• Package 30	Specify with counterweight.
	• Package 36	Specify with counterweight.
	• Package 42	Specify with counterweight.
	Two Drawer with Universal 3" bases	
	• Package 3	Specify with counterweight.
	• Package 4	Specify with counterweight.
	Two Drawer with c:scape glide bases	
	• Package 30	Specify with counterweight.
	• Package 42	Specify with counterweight.
Lock and Keying	Lock	
	• Ember Chrome	Specify with 9250 Ember Chrome lock.
	Individual locking drawers	
	• 18"D with two drawers • 24"D with two drawers	Specify with individual lock. Specify with individual lock.
	Keying	
	• Factory- and field-installed keying	► Page 441

► Specification Information, on next page

Tip: 6"H box drawers come standard with a divider package.

Tip: Counterweight packages are required to ensure product stability and are ordered as an option or separately. Product specification pages indicate the correct counterweight package for each style number and any exceptions where counterweights are not required. ► See Counterweight Requirements for Storage Products, in the Storage Specification Guide.

Universal One-High, 1.5-High, and Two Drawer Lateral Files, with Flush Steel, Proud Steel, or Open Fronts, continued

► Options, on previous page

Tip: Height dimension listed is for units with 1" top. Overall height will vary if another top is selected.

Tip: Your specification is not complete until you add a **F** or **P** to the style number to define the front style (for example, **RLF18301_** becomes **RLF18301F** for flush steel front).

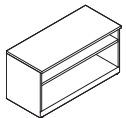
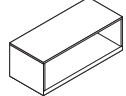
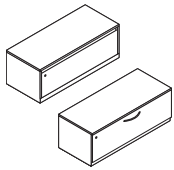

Tip: For open-open units, the shelf is affixed with screws. The screws can be removed to adjust the clips/shelf to a different height.

Specification Information

Dimensions		Counterweight Packages		Style Number			
D	W H	Universal 3" Base	c:scape Glide Base			Flush Steel Front	Proud Steel Front
Flush Steel	Proud Steel					F	P

One 12"H Drawer

18"	18 ⁷ / ₈ "	30" 16"	Package 30	Package 30	RLF18301_	•	•
18"	18 ⁷ / ₈ "	36" 16"	Package 36	Package 36	RLF18361_	•	•
18"	18 ⁷ / ₈ "	42" 16"	Package 42	Package 42	RLF18421_	•	•

Open Configurations

18"	18 ⁷ / ₈ "	30" 16"	Not required	Not required	RSC18301A_	•	•
18"	18 ⁷ / ₈ "	36" 16"	Not required	Not required	RSC18361A_	•	•
18"	18 ⁷ / ₈ "	42" 16"	Not required	Not required	RSC18421A_	•	•

Open-Open Configurations

One 6"H Opening with Fixed Shelf and One 12"H Opening with Fixed Shelf

18"	18 ⁷ / ₈ "	30" 22"	Not required	Not required	RLF18301A_	•	•
18"	18 ⁷ / ₈ "	36" 22"	Not required	Not required	RLF18361A_	•	•
18"	18 ⁷ / ₈ "	42" 22"	Not required	Not required	RLF18421A_	•	•
23 ¹ / ₈ "	24"	30" 22"	Not required	Not required	RLF24301A_	•	•
23 ¹ / ₈ "	24"	36" 22"	Not required	Not required	RLF24361A_	•	•

► Specification Information, continued on next page

► **Specification Information, continued from previous page**

Tip: Height dimension listed is for units with 1" top. Overall height will vary if another top is selected.

Tip: Your specification is not complete until you add a **F** or **P** to the style number to define the front style (for example, **RLF18301_** becomes **RLF18301F** for flush steel front).

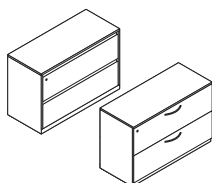
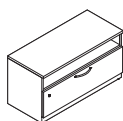
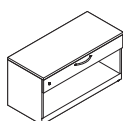
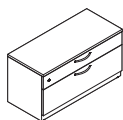

Specification Information							
Dimensions		Counterweight Packages		Style Number			
D	W H						
Flush Steel	Proud Steel	Universal 3" Base	Escape Glide Base			Flush Steel Front	Proud Steel Front
						F	P

Drawer–Drawer Configurations

One 6"H Drawer and One 12"H Drawer

18"	18 ⁷ / ₈ "	30" 22"	Package 30	Package 30	RLF18301B_	•	•
18"	18 ⁷ / ₈ "	36" 22"	Package 36	Package 36	RLF18361B_	•	•
18"	18 ⁷ / ₈ "	42" 22"	Package 42	Package 42	RLF18421B_	•	•
23 ¹ / ₈ "	24"	30" 22"	Package 30	Package 30	RLF24301B_	•	•
23 ¹ / ₈ "	24"	36" 22"	Package 36	Package 36	RLF24361B_	•	•

Drawer—Open Configurations

One 6"H Drawer and One 12"H Opening with Fixed Shelf

18"	18 ⁷ / ₈ "	30" 22"	Package D	Package D	RLF18301C_	•	•
18"	18 ⁷ / ₈ "	36" 22"	Package E	Package E	RLF18361C_	•	•
18"	18 ⁷ / ₈ "	42" 22"	Package F	Package F	RLF18421C_	•	•
23 ¹ / ₈ "	24"	30" 22"	Package D	Package D	RLF24301C_	•	•
23 ¹ / ₈ "	24"	36" 22"	Package E	Package E	RLF24361C_	•	•

Open—Drawer Configurations

One 6"H Opening with Fixed Shelf and One 12"H Drawer

18"	18 ⁷ / ₈ "	30" 22"	Package 30	Package 30	RLF18301D_	•	•
18"	18 ⁷ / ₈ "	36" 22"	Package 36	Package 36	RLF18361D_	•	•
18"	18 ⁷ / ₈ "	42" 22"	Package 42	Package 42	RLF18421D_	•	•
23 ¹ / ₈ "	24"	30" 22"	Package 30	Package 30	RLF24301D_	•	•
23 ¹ / ₈ "	24"	36" 22"	Package 36	Package 36	RLF24361D_	•	•

Two 12"H Drawers

18"	18 ⁷ / ₈ "	30" 28"	Package 3	Package 30	RLF18302_	•	•
18"	18 ⁷ / ₈ "	36" 28"	Package 4	Package 30	RLF18362_	•	•
18"	18 ⁷ / ₈ "	42" 28"	Package 4	Package 30	RLF18422_	•	•
23 ¹ / ₈ "	24"	30" 28"	Package 3	Package 30	RLF24302_	•	•
23 ¹ / ₈ "	24"	36" 28"	Package 4	Package 30	RLF24362_	•	•

Storage

Universal Open Side Towers

With Flush Steel or Proud Steel Fronts

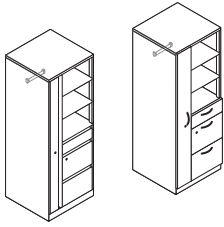

Standard Includes		Required to Specify
<p>▶ See <i>Storage Specification Guide</i> for product details.</p> <ul style="list-style-type: none"> • Tower: paint price group 1 • 1"H top: paint to match tower • Lock, keyed random: 9201 Polished Chrome • Base (see below under required selections) • Pulls: metal • Integral pulls on units with flush steel fronts • Drawer body: black only • Adjustable shelves on 52"H and 65½"H: paint to match tower • Brackets for adjustable shelves: black • Post to support adjustable shelf: paint to match tower • One box drawer divider and one pencil tray: black only • Coat rod: black • Four adjustable leveling glides • Ganging hardware 		<ul style="list-style-type: none"> 1 Style number with appropriate front style in the space provided <ul style="list-style-type: none"> F Flush steel front P Proud steel front 2 Paint color number for tower 3 Base (see below under required selections) 4 Pull (see below under required selections) 5 Metal color number for pulls, if proud steel front selected 6 Options, if selected (see below) <p>▶ See <i>Surface Materials</i>, page 480.</p>

Required Selections		Required to Specify
<p>Bases</p> <ul style="list-style-type: none"> • Universal 3" base • c:scape glide base 		<p>Specify with <i>Universal 3" base</i>, painted to match tower.</p> <p>Specify with <i>c:scape glide base</i>, 4799 Platinum Metallic only.</p>

Pulls

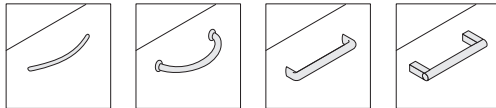

Contemporary Handle Jazz Bar

Options		Required to Specify
<p>Surface Materials</p> <ul style="list-style-type: none"> • Paint price group 1 • Paint price group 2 		<p>Specify paint color number.</p> <p>Specify paint color number.</p>
<p>Tops for Flush Steel Front, Proud Steel Front</p>	<p>Laminate top</p> <ul style="list-style-type: none"> • Square edge laminate price group 1 top • Square edge laminate price group 3 top 	<p>Specify with <i>laminate top</i> and indicate laminate color number for top and plastic color number for edges.</p> <p>Specify with <i>laminate top</i> and indicate laminate color number for top and plastic color number for edges.</p>
<p>Pulls</p>	<p>Proud steel fronts</p> <ul style="list-style-type: none"> • Contemporary • Handle • Jazz • Bar 	<p>Specify with <i>contemporary pull</i>.</p> <p>Specify with <i>handle pull</i>.</p> <p>Specify with <i>jazz pull</i>.</p> <p>Specify with <i>bar pull</i>.</p>
<p>Lock and Keying</p>	<p>Lock</p> <ul style="list-style-type: none"> • Ember Chrome <p>Keying</p> <ul style="list-style-type: none"> • Factory- and field-installed keying 	<p>Specify with <i>9250 Ember Chrome lock</i>.</p> <p>▶ Page 441</p>

Tip: Laminate tops are 3/16" taller than other tops and will add 3/16" to overall case height.

Tip: Height dimension listed is for units with 1" top. Overall height will vary if another top is selected.

Tip: Your specification is not complete until you add a **F** or **P** to the style number to define the front style (for example, **RQS24244LA** becomes **RQS24244LAF** for flush steel front.)

Specification Information

Dimensions		Style Number	
D	W H		
Flush Steel Front	Proud Steel Front	Flush Steel Front	Proud Steel Front
		F	P

Tower with Door Hinged on Left

One Adjustable Shelf, One 6"H Drawer, and Two 12"H Drawers

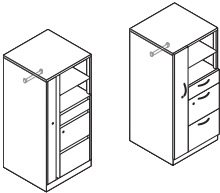

23 1/8" 24" 24" 52" **RQS24244LA** • •

Two Adjustable Shelves, One 6"H Drawer, and Two 12"H Drawers

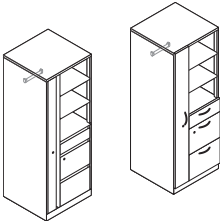

23 1/8" 24" 24" 65 1/2" **RQS24245LC** • •

One Adjustable Shelf, One 6"H Drawer, and Two 12"H Drawers

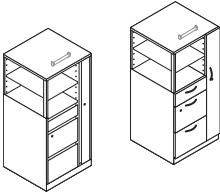

23 1/8" 24" 24" 52" **RQS24244RA** • •

Two Adjustable Shelves, One 6"H Drawer, and Two 12"H Drawers

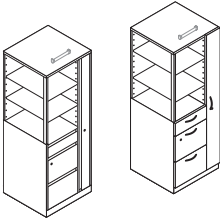

23 1/2" 24" 24" 65 1/2" **RQS24245RC** • •



Universal Lateral Files

With Flush Steel or Proud Steel Fronts

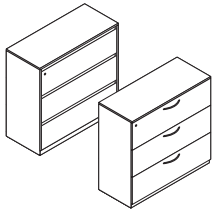

Standard Includes		Required to Specify
<ul style="list-style-type: none"> ▶ See <i>Storage Specification Guide</i> for product details. 	<ul style="list-style-type: none"> Lateral file: paint price group 1 1"H top on units with flush steel or proud steel fronts: paint to match file Integral pulls on units with flush steel front Pulls: metal Lift-up door with fixed shelf on 65½"H units with flush steel or proud steel front: paint price group 1 Central lock, keyed random: 9201 Polished Chrome One label holder per drawer: clear plastic Drawer body: black only Drawer suspensions: black only One hanging folder bar per drawer on 18"D units Two rails per drawer on 24"D units One hanging folder bar and three dividers on roll-out shelf, if selected Four adjustable leveling glides Ganging hardware Counterweight package, if selected 	<ol style="list-style-type: none"> Style number with appropriate front style in the space provided <ul style="list-style-type: none"> F Flush steel front P Proud steel front Paint color number for file Pull (see below under required selections) Metal color number for pulls, if proud steel front selected Options, if selected (see below) <ul style="list-style-type: none"> ▶ See <i>Surface Materials</i>, page 480.

Required Selections

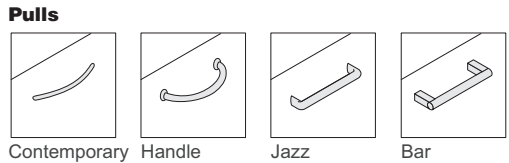

Options		Required to Specify
Surface Materials	<ul style="list-style-type: none"> Paint price group 1 Paint price group 2 	Specify paint color number. Specify paint color number.
Tops for Flush Steel Front and Proud Steel Front	<p>No top on 40"H or 52"H</p> <ul style="list-style-type: none"> For use under a worksurface or beneath a common top <p>Tops for laminate top</p> <ul style="list-style-type: none"> Square edge laminate price group 1 top Square edge laminate price group 3 top 	Specify <i>with no top</i> . Specify <i>with laminate top</i> and indicate laminate color number for top and plastic color number for edges. Specify <i>with laminate top</i> and indicate laminate color number for top and plastic color number for edges.
Drawer Interiors	<ul style="list-style-type: none"> HF bar for use on 24"D units only Divider package Rails for use on 18"D units only 	Specify <i>with HF bar</i> . Specify <i>with divider package</i> . Specify <i>with rails</i> .
Lift-Up Door With Roll-Out Shelf	<p>65½"H flush steel front files only</p> <ul style="list-style-type: none"> On 18"D files On 24"D files 	Specify <i>with roll-out shelf</i> . Specify <i>with roll-out shelf</i> .
Pulls	<p>Proud steel fronts</p> <ul style="list-style-type: none"> Contemporary Handle Jazz Bar 	Specify <i>with contemporary pull</i> . Specify <i>with handle pull</i> . Specify <i>with jazz pull</i> . Specify <i>with bar pull</i> .

▶ Options, continued on next page

Tip: Laminate tops are 3/16" taller than other tops and will add 3/16" to overall case height.

► Options, continued from previous page

Tip: Counterweight packages are required to ensure product stability and are ordered as an option or separately. Product specification pages indicate the correct counterweight package for each style number and any exceptions where counterweights are not required. ► See Counterweight Requirements for Storage Products, see the Storage Specification Guide.

Tip: 65½"H files with individual lock option do not have a lock in the lift-up door. Lift-up door is locked by the drawer below.

Tip: Height dimension listed is for units with 1" top. Overall height will vary if another top is selected.

Tip: Your specification is not complete until you add **F** or **P** to the style number to define the front style (for example, **RLF18363** becomes **RLF18363F** for flush steel front).

Options		Required to Specify
Counterweights	<ul style="list-style-type: none"> • Package 1 • Package 2 • Package 3 • Package 4 	Specify with counterweight. Specify with counterweight. Specify with counterweight. Specify with counterweight.
Lock and Keying	<p>Lock</p> <ul style="list-style-type: none"> • Ember Chrome <p>Individual locking drawers on 18"D file</p> <ul style="list-style-type: none"> • With three drawers • With four drawers <p>Individual locking drawers on 24"D file</p> <ul style="list-style-type: none"> • With three drawers • With four drawers <p>Keying</p> <ul style="list-style-type: none"> • Factory- and field-installed keying 	Specify with 9250 Ember Chrome lock. Specify with individual lock. Specify with individual lock. Specify with individual lock. Specify with individual lock.

► Page 441

Specification Information						
Dimensions D	W H		Counterweight Package	Style Number	Flush Steel Front	Proud Steel Front
	Flush Steel Front	Proud Steel Front				
18"	18 7/8"	30" 40"	Package 3	RLF18303__	•	•
18"	18 7/8"	36" 40"	Package 3	RLF18363__	•	•
18"	18 7/8"	42" 40"	Package 3	RLF18423__	•	•
23 1/8"	24"	30" 40"	Package 2	RLF24303__	•	•
23 1/8"	24"	36" 40"	Package 2	RLF24363__	•	•
:	:	:	:	:	F	P

Three 12"H Drawers

18"	18 7/8"	30" 40"	Package 3	RLF18303__	•	•
18"	18 7/8"	36" 40"	Package 3	RLF18363__	•	•
18"	18 7/8"	42" 40"	Package 3	RLF18423__	•	•
23 1/8"	24"	30" 40"	Package 2	RLF24303__	•	•
23 1/8"	24"	36" 40"	Package 2	RLF24363__	•	•
:	:	:	:	:	:	:

Four 12"H Drawers

18"	18 7/8"	30" 52"	Package 3	RLF18304__	•	•
18"	18 7/8"	36" 52"	Package 4	RLF18364__	•	•
18"	18 7/8"	42" 52"	Package 4	RLF18424__	•	•
23 1/8"	24"	30" 52"	Package 2	RLF24304__	•	•
23 1/8"	24"	36" 52"	Package 3	RLF24364__	•	•
:	:	:	:	:	:	:

Four 12"H Drawers and One 13½"H Lift-Up Door with Fixed Shelf

18"	18 7/8"	30" 65 1/2"	Package 2	RLF18305__	•	•
18"	18 7/8"	36" 65 1/2"	Package 2	RLF18365__	•	•
18"	18 7/8"	42" 65 1/2"	Package 3	RLF18425__	•	•
23 1/8"	24"	30" 65 1/2"	Package 1	RLF24305__	•	•
23 1/8"	24"	36" 65 1/2"	Package 1	RLF24365__	•	•
:	:	:	:	:	:	:

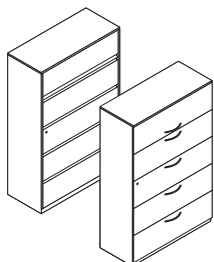
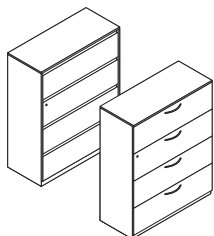
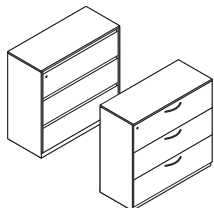

Universal Storage Cabinets

With Flush Steel or Proud Steel Fronts

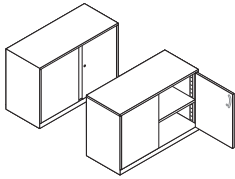

Standard Includes	Required to Specify
<ul style="list-style-type: none"> ▶ See <i>Storage Specification Guide</i> for product details. Storage cabinet: paint price group 1 1"H top on units with flush steel or proud steel fronts: paint to match cabinet Integral pulls on units with flush steel fronts Pulls: metal Hinged doors on units with flush steel or proud steel front: paint to match cabinet Lock, keyed random: 9201 Polished Chrome Adjustable shelves: paint to match cabinet Brackets for adjustable shelves: black Ganging hardware Four adjustable leveling glides 	<ol style="list-style-type: none"> Style number with appropriate front style in the space provided <ul style="list-style-type: none"> F Flush steel front P Proud steel front Paint color number for cabinet Pull (see below under required selections) Metal color number for pulls, if proud steel front selected Options, if selected (see below) <ul style="list-style-type: none"> ▶ See <i>Surface Materials</i>, page 480.

Required Selections

Pulls

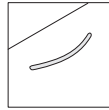

Contemporary

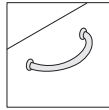

Handle

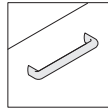

Jazz

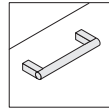

Bar

Options

Options	Required to Specify
Surface Materials <ul style="list-style-type: none"> Paint price group 1 Paint price group 2 	Specify paint color number. Specify paint color number.
Tops for Flush Steel Front and Proud Steel Front <ul style="list-style-type: none"> Security top <ul style="list-style-type: none"> For use on 28"H storage cabinets only No top on 28"H, 40"H, or 52"H <ul style="list-style-type: none"> For use under a worksurface or beneath a common top Laminate top <ul style="list-style-type: none"> Square edge laminate price group 1 top Square edge laminate price group 3 top 	Specify <i>with security top</i> . Specify <i>with no top</i> . Specify <i>with laminate top</i> and indicate laminate color number for top and plastic color number for edges. Specify <i>with laminate top</i> and indicate laminate color number for top and plastic color number for edges.
Pulls <ul style="list-style-type: none"> Proud steel fronts <ul style="list-style-type: none"> Contemporary Handle Jazz Bar 	Specify <i>with contemporary pull</i> . Specify <i>with handle pull</i> . Specify <i>with jazz pull</i> . Specify <i>with bar pull</i> .
Lock and Keying <ul style="list-style-type: none"> Lock <ul style="list-style-type: none"> Ember Chrome Keying <ul style="list-style-type: none"> Factory- and field-installed keying 	Specify <i>with 9250 Ember Chrome lock</i> . ▶ Page 441

Tip: Security top reduces overall height by approximately 1".

Tip: Height dimension listed is for units with 1" top. Overall height will vary if another top is selected.

Tip: Your specification is not complete until you add a **F** or **P** to the style number to define the front style (for example, **RSC18302A** becomes **RSC18302AF** for flush steel front).

Specification Information

Dimensions		W	H	Counter-weight Package	Style Number	Flush Steel Front	Proud Steel Front
D	Front						
						F	P

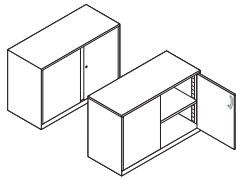

28"H Storage Cabinet

With One Adjustable Shelf

18"	18 ⁷ / ₈ "	30"	28"	Not required	RSC18302A __	•	•
18"	18 ⁷ / ₈ "	36"	28"	Not required	RSC18362A __	•	•
18"	18 ⁷ / ₈ "	42"	28"	Not required	RSC18422A __	•	•
23 ¹ / ₈ "	24"	30"	28"	Not required	RSC24302A __	•	•
23 ¹ / ₈ "	24"	36"	28"	Not required	RSC24362A __	•	•

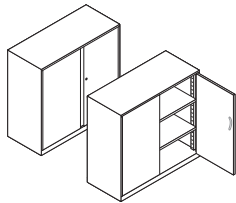

40"H Storage Cabinet

With Two Adjustable Shelves

18"	18 ⁷ / ₈ "	30"	40"	Not required	RSC18303C __	•	•
18"	18 ⁷ / ₈ "	36"	40"	Not required	RSC18363C __	•	•
18"	18 ⁷ / ₈ "	42"	40"	Not required	RSC18423C __	•	•
23 ¹ / ₈ "	24"	30"	40"	Not required	RSC24303C __	•	•
23 ¹ / ₈ "	24"	36"	40"	Not required	RSC24363C __	•	•

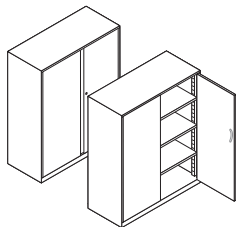

52"H Storage Cabinet

With Three Adjustable Shelves

18"	18 ⁷ / ₈ "	30"	52"	Not required	RSC18304F __	•	•
18"	18 ⁷ / ₈ "	36"	52"	Not required	RSC18364F __	•	•
18"	18 ⁷ / ₈ "	42"	52"	Not required	RSC18424F __	•	•
23 ¹ / ₈ "	24"	30"	52"	Not required	RSC24304F __	•	•
23 ¹ / ₈ "	24"	36"	52"	Not required	RSC24364F __	•	•

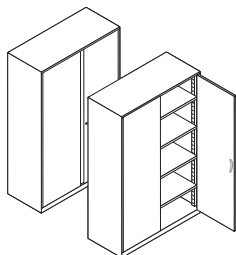

65¹/₂"H Storage Cabinet

With Four Adjustable Shelves

18"	18 ⁷ / ₈ "	30"	65 ¹ / ₂ "	Not required	RSC18305K __	•	•
18"	18 ⁷ / ₈ "	36"	65 ¹ / ₂ "	Not required	RSC18365K __	•	•
18"	18 ⁷ / ₈ "	42"	65 ¹ / ₂ "	Not required	RSC18425K __	•	•
23 ¹ / ₈ "	24"	30"	65 ¹ / ₂ "	Not required	RSC24305K __	•	•
23 ¹ / ₈ "	24"	36"	65 ¹ / ₂ "	Not required	RSC24365K __	•	•

► **Specification Information, continued on next page**

Storage

► **Specification Information, continued from previous page**

Tip: Height dimension listed is for units with 1" top. Overall height will vary if another top is selected.

Tip: Your specification is not complete until you add a **F** or **P** to the style number to define the front style (for example, **RSC18302A** becomes **RSC18302AF** for flush steel front).

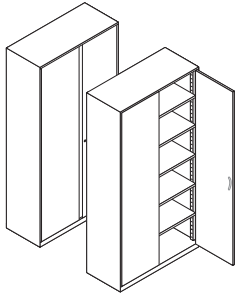

Specification Information							
Dimensions		W	H	Counter-weight Package	Style Number	Flush Steel Front	Proud Steel Front
D	Front						
						F	P

83 1/2"H Storage Cabinet

With Five Adjustable Shelves

18"	18 7/8"	30"	83 1/2"	Not required	RSC18306Q __	•	•
18"	18 7/8"	36"	83 1/2"	Not required	RSC18366Q __	•	•
18"	18 7/8"	42"	83 1/2"	Not required	RSC18426Q __	•	•
23 1/8"	24"	30"	83 1/2"	Not required	RSC24306Q __	•	•
23 1/8"	24"	36"	83 1/2"	Not required	RSC24366Q __	•	•
:	:	:	:	:	:	:	:

Universal Bookcases

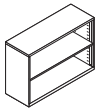

Standard Includes	Required to Specify
<ul style="list-style-type: none"> ▶ See <i>Storage Specification Guide</i> for product details. • Bookcase: paint price group 1 • 1"H top: paint to match bookcase • Adjustable shelves: paint to match bookcase • Brackets for shelves: black • Four adjustable leveling glides • Ganging hardware • Counterweight package, if selected 	<ol style="list-style-type: none"> 1 Style number 2 Paint color number for bookcase and counterweight cover, if selected 3 Options, if selected (see below) <ul style="list-style-type: none"> ▶ See <i>Surface Materials</i>, page 480.

Options	Required to Specify
<p>Surface Materials</p> <p>28"H, 40"H, 53½"H, or 65½"H bookcases</p> <ul style="list-style-type: none"> • Paint price group 1 • Paint price group 2 <hr/> <p>83½"H bookcases</p> <ul style="list-style-type: none"> • Paint price group 1 • Paint price group 2 	<p>Specify paint color number.</p> <p>Specify paint color number.</p> <hr/> <p>Specify paint color number.</p> <p>Specify paint color number.</p>
<p>Tops</p> <p>Security top</p> <ul style="list-style-type: none"> • For use on 28"H bookcases only <hr/> <p>No top on 28"H, 40"H, or 53½"H</p> <ul style="list-style-type: none"> • For use under a worksurface or beneath a common top <hr/> <p>Laminate top</p> <ul style="list-style-type: none"> • Square edge laminate price group 1 top • Square edge laminate price group 3 top 	<p>Specify <i>with security top</i>.</p> <hr/> <p>Specify <i>with no top</i>.</p> <hr/> <p>Specify <i>with laminate top</i> and indicate laminate color number for top and plastic color number for edges.</p> <p>Specify <i>with laminate top</i> and indicate laminate color number for top and plastic color number for edges.</p>
<p>Counterweights with Cover</p> <p>65½"H and 83½"H bookcases</p> <ul style="list-style-type: none"> • Package for 24"W bookcases • Package for 30"W bookcases • Package for 36"W bookcases • Package for 42"W bookcases 	<p>Specify <i>with counterweight</i>.</p> <p>Specify <i>with counterweight</i>.</p> <p>Specify <i>with counterweight</i>.</p> <p>Specify <i>with counterweight</i>.</p>

Tip: Security top reduces overall height by approximately 1".

Tip: Laminate tops are 3/16" taller than other tops and will add 3/16" to overall case height.

Tip: Cover of optional counterweight will match paint color of bookcase.

Tip: Counterweight packages are required to ensure product stability and are ordered as an option or separately. Product specification pages indicate the correct counterweight package for each style number and any exceptions where counterweights are not required.

▶ See *Counterweight Requirements for Storage Products*, in the *Storage Specification Guide*.

Tip: Service part Y30291SR, (paintable black plug), can be ordered to cover the glide adjustment holes in the front of the bookcase.

Tip: Height dimension listed is for units with 1" top. Overall height will vary if another top is selected.

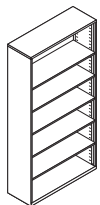
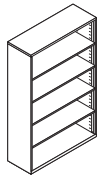
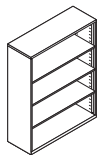
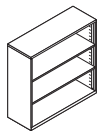
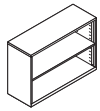

Specification Information

Dimensions			Counterweight Package	Style Number
D	W	H		

Bookcases with Adjustable Shelves

One Adjustable Shelf

15"	24"	28"	Not required	RBC15242A
15"	30"	28"	Not required	RBC15302A
15"	36"	28"	Not required	RBC15362A
15"	42"	28"	Not required	RBC15422A

Two Adjustable Shelves

15"	24"	40"	Not required	RBC15243A
15"	30"	40"	Not required	RBC15303A
15"	36"	40"	Not required	RBC15363A
15"	42"	40"	Not required	RBC15423A

Three Adjustable Shelves

15"	24"	53½"	Not required	RBC15244A
15"	30"	53½"	Not required	RBC15304A
15"	36"	53½"	Not required	RBC15364A
15"	42"	53½"	Not required	RBC15424A

Four Adjustable Shelves

15"	24"	65½"	24"W Package	RBC15245A
15"	30"	65½"	30"W Package	RBC15305A
15"	36"	65½"	36"W Package	RBC15365A
15"	42"	65½"	42"W Package	RBC15425A

Five Adjustable Shelves

15"	24"	83½"	24"W Package	RBC15246A
15"	30"	83½"	30"W Package	RBC15306A
15"	36"	83½"	36"W Package	RBC15366A
15"	42"	83½"	42"W Package	RBC15426A

Universal Storage Field Installed Tops

Steel Security Tops

For Use with Flush or Proud Front Products

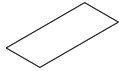

Tip: Tops are for field installation only.

Tip: Security tops should only be used on units that are positioned under a work surface—these are **NOT** structural tops.

Tip: Security top cannot be installed on a file with a lift-up door in the top position.

Tip: For use with universal steel storage only.

Standard Includes	Required to Specify
<ul style="list-style-type: none"> ▶ See <i>Storage Specification Guide</i> for product details. • Security top: paint price groups 1 and 2 • Attachment hardware 	<ul style="list-style-type: none"> 1 Style number 2 Paint color number for top ▶ See <i>Surface Materials</i>, page 480.

Specification Information

Dimensions		For Use On	Style Number
D	W		

Flush Front

15"	24"	Bookcase	RATF1524
15"	30"	Bookcase	RATF1530
15"	36"	Bookcase	RATF1536
15"	42"	Bookcase	RATF1542
18"	30"	Lateral file, storage cabinet	RATF1830F
18"	36"	Lateral file, storage cabinet	RATF1836F
18"	42"	Lateral file, storage cabinet	RATF1842F
23½"	30"	Lateral file, storage cabinet	RATF2430F
23½"	36"	Lateral file, storage cabinet	RATF2436F

Proud Front

18⅞"	30"	Lateral file, storage cabinet	RATF1830P
18⅞"	36"	Lateral file, storage cabinet	RATF1836P
18⅞"	42"	Lateral file, storage cabinet	RATF1842P
24"	30"	Lateral file, storage cabinet	RATF2430P
24"	36"	Lateral file, storage cabinet	RATF2436P

Modular Square Edge Tops

For Use with Flush or Proud Front Products

Tip: See SmartTools for common tops placed over group storage and placed back-to-back to ensure correct sizing for the application.

Tip: Attachment hardware ships with the file cabinet. Additional screws can be ordered from Service Parts: 855010126MP (quantity of 100).

*Tip: Your specification is not complete until you add a **F** or **P** to the style number to define the front style (for example, **RATL1524** becomes **RATL1524F** for a top to be used on a flush front unit).*

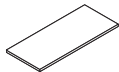

Standard Includes	Required to Specify
-------------------	---------------------

<ul style="list-style-type: none"> ▶ See <i>Storage Specification Guide</i> for product details. 	<ul style="list-style-type: none"> • 1³/₁₆"H top with square edge profile on all sides: laminate price group 1 	<ol style="list-style-type: none"> 1 Style number with appropriate front style (if required) in the space provided <ul style="list-style-type: none"> F Flush steel front P Proud steel, proud composite veneer or wood front 2 Laminate color number for top 3 Plastic color number for 1 mm edges of laminate top 4 Options, if selected (see below) <ul style="list-style-type: none"> ▶ See <i>Surface Materials</i>, page 480.
---	---	--

Options	Required to Specify
---------	---------------------

Surface Materials	Laminate top <ul style="list-style-type: none"> • Laminate price group 3 	Specify laminate color number.
--------------------------	--	--------------------------------

Specification Information						
---------------------------	--	--	--	--	--	--

• Dimensions			• Style Number				
D	W	H	Flush Steel Front	Proud Steel/ Proud Comp Ven/ Wood	Flush Steel Front	Proud Steel or Proud Comp Ven Front	Proud Wood Front
.....
.....	F	P	P

Individual File Laminate Tops

15"	N.A.	24"	1 ³ / ₁₆ "	RATL1524 __	•	N.A.	N.A.
15"	N.A.	30"	1 ³ / ₁₆ "	RATL1530 __	•	N.A.	N.A.
15"	N.A.	36"	1 ³ / ₁₆ "	RATL1536 __	•	N.A.	N.A.
15"	N.A.	42"	1 ³ / ₁₆ "	RATL1542 __	•	N.A.	N.A.
18"	18 ⁷ / ₈ "	30"	1 ³ / ₁₆ "	RATL1830 __	•	•	•
18"	18 ⁷ / ₈ "	36"	1 ³ / ₁₆ "	RATL1836 __	•	•	•
18"	18 ⁷ / ₈ "	42"	1 ³ / ₁₆ "	RATL1842 __	•	•	•
23 ¹ / ₈ "	24"	30"	1 ³ / ₁₆ "	RATL2430 __	•	•	•
23 ¹ / ₈ "	24"	36"	1 ³ / ₁₆ "	RATL2436 __	•	•	•
.....	•

▶ **Specification Information, continued on next page**

► Specification Information, continued from previous page

Tip: Your specification is not complete until you add a **F** or **P** to the style number to define the front style (for example, **RATL1524_** becomes **RATL1524F** for a top to be used on a flush front unit).

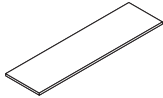

Specification Information

Dimensions			Style Number	Flush Steel Front	Proud Steel or Proud Comp Ven Front	Proud Wood Front
D	W	H				
Flush Steel Front	Proud Steel/ Proud Comp Ven/Wood			F	P	P

Laminate Common Tops

15"	N.A.	48 1/16"	1 3/16"	RATCL1548_	•	N.A.	N.A.
15"	N.A.	60 1/16"	1 3/16"	RATCL1560_	•	N.A.	N.A.
15"	N.A.	66 1/16"	1 3/16"	RATCL1566_	•	N.A.	N.A.
15"	N.A.	72 1/16"	1 3/16"	RATCL1572_	•	N.A.	N.A.
15"	N.A.	78 1/16"	1 3/16"	RATCL1578_	•	N.A.	N.A.
15"	N.A.	84 1/16"	1 3/16"	RATCL1584_	•	N.A.	N.A.
15"	N.A.	90 1/8"	1 3/16"	RATCL1590_	•	N.A.	N.A.
15"	N.A.	96 1/8"	1 3/16"	RATCL1596_	•	N.A.	N.A.
15"	N.A.	108 1/8"	1 3/16"	RATCL15108_	•	N.A.	N.A.
18"	18 7/8"	60 1/16"	1 3/16"	RATCL1860_	•	•	•
18"	18 7/8"	66 1/16"	1 3/16"	RATCL1866_	•	•	•
18"	18 7/8"	72 1/16"	1 3/16"	RATCL1872_	•	•	•
18"	18 7/8"	78 1/16"	1 3/16"	RATCL1878_	•	•	•
18"	18 7/8"	84 1/16"	1 3/16"	RATCL1884_	•	•	•
18"	18 7/8"	90 1/8"	1 3/16"	RATCL1890_	•	•	•
18"	18 7/8"	96 1/8"	1 3/16"	RATCL1896_	•	•	•
18"	18 7/8"	108 1/8"	1 3/16"	RATCL18108_	•	•	•
23 1/8"	24"	60 1/16"	1 3/16"	RATCL2460_	•	•	•
23 1/8"	24"	66 1/16"	1 3/16"	RATCL2466_	•	•	•
23 1/8"	24"	72 1/16"	1 3/16"	RATCL2472_	•	•	•
23 1/8"	24"	90 1/8"	1 3/16"	RATCL2490_	•	•	•
23 1/8"	24"	96 1/8"	1 3/16"	RATCL2496_	•	•	•
23 1/8"	24"	108 1/8"	1 3/16"	RATCL24108_	•	•	•
30 1/16"	N.A.	48 1/16"	1 3/16"	RATCL3048_	•	N.A.	N.A.
30 1/16"	N.A.	60 1/16"	1 3/16"	RATCL3060_	•	N.A.	N.A.
30 1/16"	N.A.	66 1/16"	1 3/16"	RATCL3066_	•	N.A.	N.A.
:	:	:	:	:	:	:	:

► Specification Information, continued on next page

► **Specification Information, continued from previous page**

Tip: Your specification is not complete until you add a **F** or **P** to the style number to define the front style (for example, **RATL1524_** becomes **RATL1524F** for a top to be used on a flush front unit).

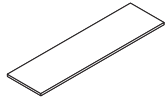

Specification Information						
Dimensions			Style			
D	W	H	Number	Flush Steel Front	Proud Steel or Proud Comp Ven Front	Proud Wood Front
				F	P	P

Laminate Common Tops, continued

30 ¹ / ₁₆ "	N.A.	72 ¹ / ₁₆ "	13 ¹ / ₁₆ "	RATCL3072_	•	N.A.	N.A.
30 ¹ / ₁₆ "	N.A.	78 ¹ / ₁₆ "	13 ¹ / ₁₆ "	RATCL3078_	•	N.A.	N.A.
30 ¹ / ₁₆ "	N.A.	84 ¹ / ₁₆ "	13 ¹ / ₁₆ "	RATCL3084_	•	N.A.	N.A.
30 ¹ / ₁₆ "	N.A.	90 ¹ / ₈ "	13 ¹ / ₁₆ "	RATCL3090_	•	N.A.	N.A.
30 ¹ / ₁₆ "	N.A.	96 ¹ / ₈ "	13 ¹ / ₁₆ "	RATCL3096_	•	N.A.	N.A.
30 ¹ / ₁₆ "	N.A.	108 ¹ / ₈ "	13 ¹ / ₁₆ "	RATCL30108_	•	N.A.	N.A.
36 ¹ / ₁₆ "	37 ¹³ / ₁₆ "	36"	13 ¹ / ₁₆ "	RATCL3636_	•	•	•
36 ¹ / ₁₆ "	37 ¹³ / ₁₆ "	72 ¹ / ₁₆ "	13 ¹ / ₁₆ "	RATCL3672_	•	•	•
46 ⁵ / ₁₆ "	48 ¹ / ₁₆ "	36"	13 ¹ / ₁₆ "	RATCL4836_	•	•	•
46 ⁵ / ₁₆ "	48 ¹ / ₁₆ "	72 ¹ / ₁₆ "	13 ¹ / ₁₆ "	RATCL4872_	•	•	•
:	:	:	:	:	:	:	:

Universal Common Tops

For Ology Application

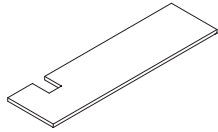

Drawing shows right-hand application, left hand is also available.

Standard Includes	Required to Specify
<ul style="list-style-type: none"> ▶ See <i>Storage Specification Guide</i> for product details. • 1$\frac{3}{16}$"H top: laminate price group 1 – edge: plastic 	<ol style="list-style-type: none"> 1 Style number 2 Width (see below under Required Selections) 3 Laminate color number for top, if laminate top selected 4 Plastic color number for edge 5 Front style (see below under Required Selections) 6 Application (see below under Required Selections) 7 Options, if selected (see below) <ul style="list-style-type: none"> ▶ See <i>Surface Materials</i>, page 480.

Required Selections	Required to Specify
Width <ul style="list-style-type: none"> • 60"W • 66"W • 72"W • 78"W • 84"W • 90"W • 96"W • 108"W 	Specify with 60" width. Specify with 66" width. Specify with 72" width. Specify with 78" width. Specify with 84" width. Specify with 90" width. Specify with 96" width. Specify with 108" width.
Front Style <ul style="list-style-type: none"> • Flush front • Proud front 	Specify with flush front. Specify with proud front.
Application <ul style="list-style-type: none"> • Right hand • Left hand 	Specify with right-hand application. Specify with left-hand application.

Tip: Right-hand or left-hand application is determined by which leg of the Ology desk is located inside the storage.

Options	Required to Specify
Surface Materials <ul style="list-style-type: none"> • Laminate top • High-Pressure Laminate price group 3 	Specify laminate color number.

Specification Information			
Style Number	Dimensions		
	D	W	
		Flush Front	Proud Front
RATCTHAD	18"	18 $\frac{7}{8}$ "	60"
	18"	18 $\frac{7}{8}$ "	66"
	18"	18 $\frac{7}{8}$ "	72"
	18"	18 $\frac{7}{8}$ "	78"
	18"	18 $\frac{7}{8}$ "	84"
	18"	18 $\frac{7}{8}$ "	90"
	18"	18 $\frac{7}{8}$ "	96"
	18"	18 $\frac{7}{8}$ "	108"

Storage

Universal Storage Adjustable Shelves

Adjustable Steel Standard Shelves

For Use with Towers



Tip: Adjustable shelves are for field installation only.

Standard Includes	Required to Specify
<ul style="list-style-type: none"> ▶ See <i>Storage Specification Guide</i> for product details. • ¾"H adjustable shelf: all paint price groups • Set of adjustable brackets: black only 	<ul style="list-style-type: none"> 1 Style number 2 Paint color number for shelf ▶ See <i>Surface Materials</i>, page 480.

Specification Information		
Dimensions		Style Number
D	W	

For Use with Open Side Towers

24"	15"	RXSA2415
30"	15"	RXSA3015

Adjustable Steel Standard Shelves

For Use with Bookcases, Combination Cabinets, and Storage Cabinets

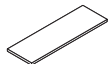

Tip: Adjustable shelves are for field installation only.

Standard Includes	Required to Specify
<ul style="list-style-type: none"> ▶ See <i>Storage Specification Guide</i> for product details. • ¾"H adjustable shelf: all paint price groups • Set of four adjustable brackets: black only 	<ul style="list-style-type: none"> 1 Style number 2 Paint color number for shelf ▶ See <i>Surface Materials</i>, page 480.

Specification Information		
Dimensions		Style Number
D	W	

For Use with Bookcases

15"	24"	RXSA1524
15"	30"	RXSA1530
15"	36"	RXSA1536
15"	42"	RXSA1542

For Use with Combination Cabinets and Storage Cabinets

18"	30"	RXSA1830
18"	36"	RXSA1836
18"	42"	RXSA1842
24"	24"	RXSA2424
24"	30"	RXSA2430
24"	36"	RXSA2436

Tip: When ordering additional adjustable shelves for cabinets with partitions, note that the partition and coat space occupy 6" of the case interior. Order shelves 6" shorter than the overall width of the cabinet.

Rails

For Use in Pedestals Manufactured after February 22, 2004
For Use in Universal Towers

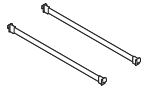

Tip: Two rails per drawer accommodate side-to-side filing of letter-, A4-, and legal-size hanging folders. Exception: Legal-size file folders cannot be filed in 18"D pedestals.

Tip: For pedestals manufactured on or before February 22, 2004, see Service Parts catalog.

Standard Includes	Required to Specify
<ul style="list-style-type: none"> See <i>Storage Specification Guide</i> for product details. Package of two rails: black only 	Style number

Specification Information	
Width	Style Number
12"	RXADRL15
:	:
:	:

Dividers

For Use in Pedestals Manufactured after February 22, 2004
For Use in Universal Towers

Tip: For pedestals manufactured on or before February 22, 2004, see Service Parts catalog.

Standard Includes	Required to Specify
<ul style="list-style-type: none"> See <i>Storage Specification Guide</i> for product details. Package of dividers: black only 	Style number

Specification Information		
Width	Quantity	Style Number
:	:	:
:	:	:

For Use in 6"H Drawers

12"	2	RDV1506
:	:	:

For Use in 12"H Drawers

12"	2	RDV1512
12"	10	RDV151210
:	:	:



Hanging Folder Bars

For Use with Universal Lateral Files and Universal Combination Cabinets Manufactured on or after October 17, 2005

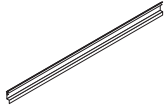

Standard Includes	Required to Specify
<ul style="list-style-type: none"> See <i>Storage Specification Guide</i> for product details. Hanging folder bar: black only 	Style number

Specification Information

Width	Style Number
30"	RAHF30
36"	RAHF36
42"	RAHF42
:	:

Rails

For Use with Lateral Files and Combination Cabinets

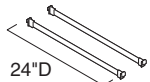
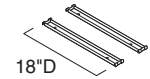

Tip: All drawer sizes require two rails per drawer for maximum capacity front-to-back filing.

Tip: Actual rail dimensions are 15½"D for an 18"D cabinet and 20"D for a 24"D cabinet.

Standard Includes	Required to Specify
<ul style="list-style-type: none"> See <i>Storage Specification Guide</i> for product details. Package of two or four rails: black only 	Style number

Specification Information

Depth	Style Number
Package of Two	
18"	800RW
24"	RXADRL24
Package of Four	
24"	RXADRL2442
:	:

Dividers

For Use in Universal Lateral Files and Combination Cabinets

Standard Includes	Required to Specify
<ul style="list-style-type: none"> ▶ See <i>Storage Specification Guide</i> for product details. • Carton of three dividers: black only 	<ul style="list-style-type: none"> Style number

Specification Information			
Dimensions			Style
D	W	H	Number

For Use in 12"H Drawers or 12"H Roll-Out Shelves			
11 ⁷ / ₈ "	1/16"	6 ¹ / ₄ "	800DV12

For Use in 6"H Roll-Out Shelves or Drawers and 9"H Drawers			
13 ¹ / ₂ "	1/16"	3 ⁵ / ₈ "	800DV6

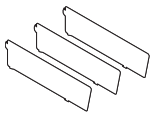

Counterweight Packages

For Use with Universal 2H, 3H, 4H, and 5H Lateral Files, and Combination Cabinets

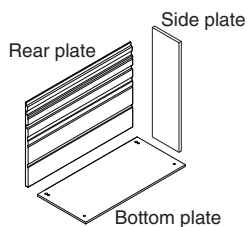

Tip: Use these counterweights with Two Drawer lateral files with Universal base.

Standard Includes	Required to Specify
<ul style="list-style-type: none"> ▶ See <i>Storage Specification Guide</i> for product details. • Counterweight: black only • Attachment hardware 	<ul style="list-style-type: none"> Style number

Specification Information	
Package Number	Style Number

Package 1	RAACW1
Package 2	RAACW2
Package 3	RAACW3
Package 4	RAACW4
Package 5	RAACW5
:	:

Storage

Counterweight Packages

For Use with Bookcases

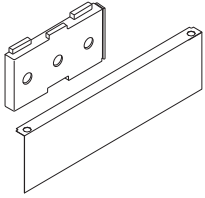

Standard Includes		Required to Specify
<ul style="list-style-type: none"> ▶ See <i>Storage Specification Guide</i> for product details. 	<ul style="list-style-type: none"> • Counterweight: black only • Cover: paint 	<ul style="list-style-type: none"> 1 Style number 2 Paint color number for cover ▶ See <i>Surface Materials</i>, page 480.
Specification Information		
For Use with	Style Number	
24"W bookcases	RAACB2401	
30"W bookcases	RAACB3001	
36"W bookcases	RAACB3601	
42"W bookcases	RAACB4201	

Anchor Bracket Package for Products with Glides

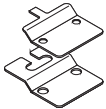

Tip: Four bracket packages are required for each cabinet.

Standard Includes		Required to Specify
<ul style="list-style-type: none"> ▶ See <i>Storage Specification Guide</i> for product details. 	<ul style="list-style-type: none"> • Two-piece anchor bracket and attachment hardware 	<ul style="list-style-type: none"> Style number
Specification Information		
Style Number		
RAANBRK		

Attachment Cable



Tip: For use with under-worksurface lateral files.

Standard Includes		Required to Specify
<ul style="list-style-type: none"> • Attachment cable 		<ul style="list-style-type: none"> Style number
Specification Information		
Style Number		
PAB12M (package of 25)		

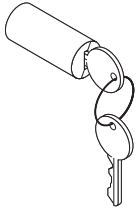

Tip: Lock price is included in price of furniture with locks.

Tip: For replacement lock cylinders, refer to Service Parts.

Standard Includes	Required to Specify
-------------------	---------------------

- Lock cylinder keyed random
- Two keys

- 1 Style number
- 2 Lock finish
9201 Polished Chrome
9250 Ember Chrome
- 3 Options, if selected (see below)

Options	Required to Specify
---------	---------------------

Key specific

Select key number from FR305–FR600.

Key consecutive

Specify *key consecutive* and must select beginning key number from FR305–FR600.

Master key random

Specify *master key random*.

Master key specific

Specify key number from XF1001–XF1299.

Master key consecutive

Specify *master key consecutive* and must select beginning key number from XF1001–XF1299.

Specification Information

- Style Number

FR Series (Standard Keying System)—Lock Cylinder

LOCKFR

Standard Lock Tool

877102003SR

XF Series (Master Keying System)—Lock Cylinder

LOCKXF

Master Lock Tool

877102002SR

Tip: You can change lock cylinders in the field by using the appropriate lock tool.

Parametric Premium Whiteboards and Tackboards

Edge Series and 110 Series

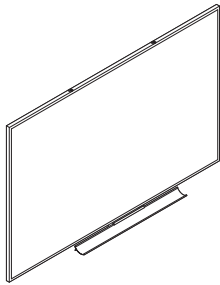

	Standard Includes	Required to Specify
▶ See <i>Collaborative Surfaces Specification Guide</i> for product details.	<ul style="list-style-type: none"> • Height: 18.25" – 48.25" • Width: 24.25" – 192.25" • e³ environmental CeramicSteel writing surface: 7655 White High Gloss • Package of four dry-erase markers (black, blue, red, and green) and one eraser on whiteboards, if selected • Fabric on tackboards, if selected • If Edge Series selected: <ul style="list-style-type: none"> – Frame and marker tray: 8043 Clear Anodized Aluminum – Metal cleat-mounting system • If 110 Series selected: <ul style="list-style-type: none"> – ¾" Frame and full-width marker tray: 8043 Clear Anodized Aluminum – Wall-anchored mounting system hardware 	<ol style="list-style-type: none"> 1 Style number 2 Size (see below under Required Selections) 3 Trim type (see below under Required Selections) 4 Height 5 Width 6 Fabric color number for tackboard, if selected 7 Options, if selected (see below) <p>▶ See <i>Surface Materials</i>, page 480.</p>

Tip: Select parametric size option to specify parametric height and width dimensions within the available range. Select modular size option to specify pre-defined height and width dimension combinations.

Tip: Parametric sizes can be specified to the 1/16 of an inch.

Tip: If width is exactly 120.25000"W, digital print or spline joint can be specified, but not both.

	Required Selections	Required to Specify
Size	<ul style="list-style-type: none"> • Parametric • Modular 	Specify <i>Parametric</i> . Specify <i>Modular</i> .
Trim Type	<ul style="list-style-type: none"> • Edge Series • 110 Series 	Specify <i>with Edge Series trim</i> . Specify <i>with 110 Series trim</i> .

	Options	Required to Specify
Surface Materials	<p>Fabric surface on tackboards</p> <ul style="list-style-type: none"> • Fabric price group 1 • Fabric price group 2 • Fabric price group 3 <p>Fabric direction on tackboards</p> <ul style="list-style-type: none"> • Horizontal application • Vertical application 	Specify fabric color number. Specify fabric color number. Specify fabric color number.
No Marker Tray	<p>Whiteboard width (inches)</p> <ul style="list-style-type: none"> • 24.25000–36.25000 • 36.31250–48.25000 • 48.31250–60.25000 • 60.31250–72.25000 • 72.31250–96.25000 • 96.31250–120.25000 • 120.31250–144.25000 • 144.31250–192.25000 	Specify <i>no tray</i> . Specify <i>no tray</i> . Specify <i>no tray</i> . Specify <i>no tray</i> . Specify <i>no tray</i> . Specify <i>no tray</i> . Specify <i>no tray</i> . Specify <i>no tray</i> .

Edge Series

Spline Joint	<ul style="list-style-type: none"> • Available on 120.25"W to 192.25"W whiteboards 	Specify <i>with spline joint</i> .
---------------------	---	------------------------------------

▶ Options, continued on next page

► Options, continued from previous page

Options	Required to Specify
110 Series	
1" Maprail Whiteboard width (inches) <ul style="list-style-type: none"> • 24.25000–36.25000 • 36.31250–48.25000 • 48.31250–60.25000 • 60.31250–72.25000 • 72.31250–96.25000 • 96.31250–120.25000 • 120.31250–144.25000 • 144.31250–192.25000 	<ul style="list-style-type: none"> Specify with <i>maprail</i>. Specify with <i>maprail</i>. Specify with <i>maprail</i>. Specify with <i>maprail</i>. Specify with <i>maprail</i>. Specify with <i>maprail</i>. Specify with <i>maprail</i>. Specify with <i>maprail</i>.
1" Map Hook/Clip Whiteboard width (inches) <ul style="list-style-type: none"> • 24.25000–60.18750 • 60.25000–120.18750 • 120.25000–144.25000 • 144.31250–192.25000 	<ul style="list-style-type: none"> Specify with <i>map hook/clip</i>. Specify with <i>map hook/clip</i>. Specify with <i>map hook/clip</i>. Specify with <i>map hook/clip</i>.
1" Flag Holder • Available on whiteboards	Specify with <i>flag holder</i> .
Roller Bracket • Available on whiteboards	Specify with <i>roller bracket</i> .
Spline Joint • Available on 120.25"W to 192.25"W whiteboards	Specify with <i>spline joint</i> .

Tip: The width of the whiteboard will determine the price of the maprail.

Tip: 1" maprail option must be selected if ordering 1" maphook/clip, 1" flag holder, or roller bracket.

Tip: The width of the whiteboard will determine the price of the hooks.

Specification Information

Style Number	Square Feet

Edge Series — Whiteboard

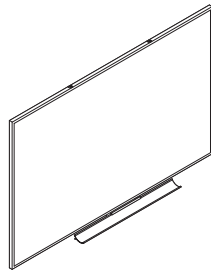

PBWTBRD	3.07335 – 5.99999
	6.00000 – 11.99999
	12.00000 – 15.99999
	16.00000 – 19.99999
	20.00000 – 23.99999
	24.00000 – 31.99999
	32.00000 – 39.99999
	40.00000 – 47.99999
	48.00000 – 63.99999
	64.00000 – 64.41710

► Specification Information, continued on next page

► **Specification Information, continued from previous page**

Specification Information

• Style Number	• Square Feet	• Options		
		• Fabric Price Group 1	• Fabric Price Group 2	• Fabric Price Group 3

Edge Series — Tackboard

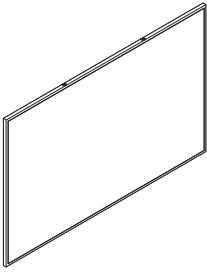

PWBTKBRD				
	3.07335 – 5.99999	•	•	•
	6.00000 – 11.99999	•	•	•
	12.00000 – 15.99999	•	•	•
	16.00000 – 19.99999	•	•	•
	20.00000 – 23.99999	•	•	•
	24.00000 – 31.99999	•	•	•
	32.00000 – 39.99999	•	•	•
	40.00000 – 40.29210	•	•	•

► **Specification Information, continued on next page**

► **Specification Information, continued from previous page**

Specification Information

Style Number	Square Feet
-----------------	----------------

110 Series—Whiteboard

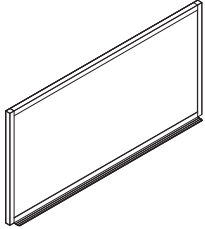

PWBWTBRD	3.07335 – 5.99999
	6.00000 – 11.99999
	12.00000 – 15.99999
	16.00000 – 19.99999
	20.00000 – 23.99999
	24.00000 – 31.99999
	32.00000 – 39.99999
	40.00000 – 47.99999
	48.00000 – 63.99999
	64.00000 – 64.41710

► **Specification Information, continued on next page**

► **Specification Information, continued from previous page**

Specification Information

• Style Number	• Square Feet	• Options		
		• Fabric Price Group 1	• Fabric Price Group 2	• Fabric Price Group 3
•	•	•	•	•
•	•	•	•	•

110 Series—Tackboard

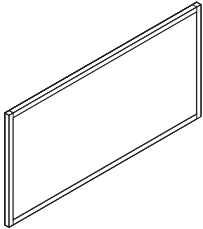

PWBTKBRD				
	3.07335 – 5.99999	•	•	•
	6.00000 – 11.99999	•	•	•
	12.00000 – 15.99999	•	•	•
	16.00000 – 19.99999	•	•	•
	20.00000 – 23.99999	•	•	•
	24.00000 – 31.99999	•	•	•
	32.00000 – 39.99999	•	•	•
	40.00000 – 40.29210	•	•	•

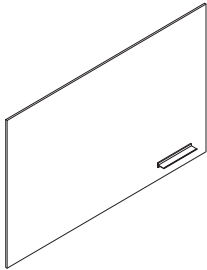

Standard Includes		Required to Specify
<ul style="list-style-type: none"> ▶ See <i>Collaborative Surfaces Specification Guide</i> for product details. 	<ul style="list-style-type: none"> Panel: Polyvision CeramicSteel Attachment hardware Magnetic marker tray, dry erase markers, and eraser if 7655 White High Gloss, 7671 Arctic White 2 CS, 7673 Merle CS, 7674 Platinum Solid CS, or PV09 Hygienic White Gloss is selected Magnetic marker tray and eraser if 7661 Gray Chalk 6502C CS is selected Accented edge: paint price groups 1, 2, and 3, if contrasting is selected 	<ol style="list-style-type: none"> Style number Size (see below under Required Selections) Corner shape (see below under Required Selections) Surface type (see below under Required Selections) CeramicSteel color number for panel: <ul style="list-style-type: none"> 7655 White High Gloss 7661 Gray Chalk 6502C CS 7663 Black 6106U CS 7671 Arctic White 2 CS 7673 Merle CS 7674 Platinum Solid CS PV09 Hygienic White Gloss Options, if selected (see below) <ul style="list-style-type: none"> ▶ See <i>Surface Materials</i>, page 480.

Tip: Accessories come with all Sans boards. Accessories vary by surface type and color. All Sans boards include a logo on the bottom right corner.

Tip: Mounting hardware will be installed on the back of the board to support vertical installation when 72"H or 95"H is specified.

Tip: Contrasting accented edge can only be specified when the panel is selected in 7655 White High Gloss and 7671 Arctic White 2 CS.

Tip: 7661 Gray Chalk 6502C CS is a true chalkboard surface. Chalk sticks and liquid chalk can be used. Liquid chalk requires wet erase.

Tip: See CeramicSteel Cleaning/Daily Care and Maintenance in Collaborative Surfaces Specification Guide for additional information.

	Required Selections	Required to Specify
Size	Horizontal	
	<ul style="list-style-type: none"> 47"H x 48"W 47"H x 72"W 47"H x 95"W 	Specify with 47"H x 48"W. Specify with 47"H x 72"W. Specify with 47"H x 95"W.
	Vertical	
	<ul style="list-style-type: none"> 72"H x 47"W 95"H x 47"W 	Specify with 72"H x 47"W. Specify with 95"H x 47"W.
Corner Shape	<ul style="list-style-type: none"> 90 degree corner Rounded corner 	Specify with 90 degree corner. Specify with rounded corner.
Surface Type	<ul style="list-style-type: none"> Chalkboard Markerboard 	Specify with chalkboard. Specify with markerboard.

	Options	Required to Specify
Surface Materials	Surface	
	<ul style="list-style-type: none"> Ceramic price group 1 Ceramic price group 2 	Specify ceramic color number. Specify ceramic color number.
	Contrasting	
	<ul style="list-style-type: none"> Non-contrasting accented edge Contrasting accented edge 	Specify with non-contrasting accented edge. Specify with contrasting accented edge.
Accessory Kit	<ul style="list-style-type: none"> Basic kit Toolbar kit 	Specify with basic kit. Specify with toolbar kit.

Specification Information					
Style Number	Dimension Height	47"W	48"W	72"W	95"W
SANS	47"	N.A.	•	•	•
	72"	•	N.A.	N.A.	N.A.
	95"	•	N.A.	N.A.	N.A.
:	:	:	:	:	:

Whiteboard

Sans Light

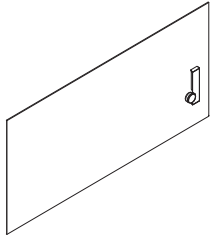

Tip: Accessories come with all Sans boards. Accessories vary by surface type and color. All Sans boards include a logo on the bottom right corner.

Tip: Mounting hardware will be installed on the back of the board to support vertical installation when 72"H or 95"H is specified.

Tip: Contrasting accented edge can only be specified when the panel is selected in 7671 Arctic White 2 CS.

Tip: 7661 Gray Chalk 6502C CS is a true chalkboard surface. Chalk sticks and liquid chalk can be used. Liquid chalk requires wet erase.

Tip: See CeramicSteel Cleaning/Daily Care and Maintenance in Collaborative Surfaces Specification Guide for additional information.

Standard Includes	Required to Specify
<ul style="list-style-type: none"> ▶ See <i>Collaborative Surfaces Specification Guide</i> for product details. • Panel: Polyvision CeramicSteel • Attachment hardware • Standard toolbar kit with 7655 White High Gloss, 7671 Arctic White 2 CS, 7674 Platinum Solid CS, or PV09 Hygienic White Gloss. Neon toolbar kit with 7673 Merle CS. Chalk toolbar kit with 7661 Gray Chalk 6502 CS. 	<ol style="list-style-type: none"> 1 Style number 2 Size (see below under Required Selections) 3 Corner shape (see below under Required Selections) 4 Surface type (see below under Required Selections) 5 CeramicSteel color number for panel: <ul style="list-style-type: none"> 7655 White High Gloss 7661 Gray Chalk 6502C CS 7663 Black 6106U CS 7671 Arctic White 2 CS 7673 Merle CS 7674 Platinum Solid CS PV09 Hygienic White Gloss 6 Options, if selected (see below) <ul style="list-style-type: none"> ▶ See <i>Surface Materials</i>, page 480.

Required Selections	Required to Specify
Size Horizontal <ul style="list-style-type: none"> • 47"H x 48"W • 47"H x 72"W • 47"H x 95"W Vertical <ul style="list-style-type: none"> • 72"H x 47"W • 95"H x 47"W 	Specify with 47"H x 48"W. Specify with 47"H x 72"W. Specify with 47"H x 95"W.
Corner Shape <ul style="list-style-type: none"> • 90 degree corner • Rounded corner 	Specify with 90 degree corner. Specify with rounded corner.
Surface Type <ul style="list-style-type: none"> • Chalkboard • Markerboard 	Specify with chalkboard. Specify with markerboard.

Options	Required to Specify
Surface Materials <ul style="list-style-type: none"> • Ceramic price group 1 • Ceramic price group 2 	Specify ceramic color number. Specify ceramic color number.
Contrasting <ul style="list-style-type: none"> • Non-contrasting accented edge • Contrasting accented edge 	Specify with non-contrasting accented edge. Specify with contrasting accented edge.

Specification Information					
Style Number	Dimension Height	• 47"W	• 48"W	• 72"W	• 95"W
PVLTSA	47"	N.A.	•	•	•
	72"	•	N.A.	N.A.	N.A.
	95"	•	N.A.	N.A.	N.A.



Tip: See CeramicSteel Cleaning/Daily Care and Maintenance for additional information.
 ▶ See *Collaborative Surfaces Specification Guide*.

Standard Includes	Required to Specify
<ul style="list-style-type: none"> Two-sided e³ CeramicSteel with urethane edge molding 	Style number

Specification Information		
• Dimensions		• Style
H	W	Number
18"	23"	VWB2

Verb Easel



Standard Includes		Required to Specify
<ul style="list-style-type: none"> ▶ See <i>Conference and Collaborative Tables Specification Guide</i> for product details. 	<ul style="list-style-type: none"> • Steel display shelves: 7360 Merle • Frame/legs: paint group 1 • Casters: black • Trough: 6249 Platinum Solid • Shipped assembled/wrapped 	<ul style="list-style-type: none"> 1 Style number 2 Frame/leg paint color number 3 Options, if selected (see below) ▶ See <i>Surface Materials</i>, page 480.

Options		Required to Specify
Surface Materials	Frame/legs <ul style="list-style-type: none"> • Paint price group 1 • Paint price group 2 	<ul style="list-style-type: none"> Specify paint color number. Specify paint color number.

Specification Information		
• Dimensions		• Style
D	W	Number
24"	36"	VE36
:	:	:



Tip: The wall track style numbers come with four or five hooks. Additional wall track hooks are available.

Standard Includes	Required to Specify
<ul style="list-style-type: none"> ▶ See <i>Conference and Collaborative Tables Specification Guide</i> for product details. • Anodized aluminum track • Cork insert • Plastic hooks 	Style number

Specification Information

• Dimensions		• Number of Plastic Hooks	• Style Number
D	W		

Wall Track

1"	6'	4	VWT6
1"	8'	5	VWT8

Wall Track Hook

		1	VWTH

Technology Worktools

Adjustable Foot Rest

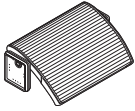

Standard Includes	Required to Specify
<ul style="list-style-type: none"> ▶ See <i>Worktools Specification Guide</i> for product details. • Adjustable foot rest: 6000 Black plastic 	Style number

Specification Information			
• Dimensions			• Style
D	W	H	Number
12"	18"	2"-6"	CFTR

Vertical Locking CPU Cradle

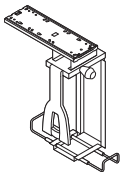

Tip: Vertical CPU cradle supports CPUs 3½"W to 9"W, 15"D to 22"D, 12½"H to 22½"H and up to 85 lb.

Tip: CPU cradle requires 18" clearance under the worksurface.

Standard Includes	Required to Specify
<ul style="list-style-type: none"> ▶ See <i>Worktools Specification Guide</i> for product details. • CPU cradle: 0835 Black • Soft touch knob with locking system for side clamp adjustment • 17" track • Lock mechanism 	Style number

Specification Information			
• Dimensions			• Style
D	W	H	Number
15"	4"	18¼"	CPRCL

Vertical Non-Locking CPU Cradle

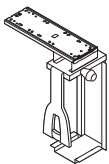

Tip: Vertical CPU cradle supports CPUs 3½"W to 9"W, 15"D to 22"D, 12½"H to 22½"H and up to 85 lb.

Tip: CPU cradle requires 18" clearance under the worksurface.

Standard Includes	Required to Specify
<ul style="list-style-type: none"> ▶ See <i>Worktools Specification Guide</i> for product details. • CPU cradle: 0835 Black • Soft touch knob for side clamp adjustment • 17"L track 	Style number

Specification Information			
• Dimensions			• Style
D	W	H	Number
17"	3½"	18¼"	CPRCCN

Vertical Processor Sling



Standard Includes		Required to Specify
▶ See <i>Worktools Specification Guide</i> for product details.	<ul style="list-style-type: none"> Vertical processor sling: 7207 Textured Black 17"L track for standard vertical processor sling 	Style number

Specification Information			
Dimensions			Style
D	W	H	Number

Fixed (For Use with FrameOne and Ology)

10 ³ / ₄ "	3 ³ / ₄ "	6"	CPRSLFO
----------------------------------	---------------------------------	----	----------------

Tracks



Tip: Attachment hardware and end cap not included. Order service part **18711701SR**, if required.

Standard Includes	Required to Specify
• Track: 0835 Black	Style number

Specification Information		
• Dimensions	• Weight	• Style
: Length	:	: Number
:	:	:
20"	3.5 lb	Q20T
23"	3.5 lb	Q23T
:	:	:

Tip: For applications that include an integrated SOTO rail: Ology, FrameOne, Campfire, Tour, or SOTO rail; specify dash rail mount with integrated SOTO bracket. dash can be mounted in front of privacy screens, Slatwall, or FrameOne center screen.

Tip: 90° mini extension cord can be used with Ology bench, FrameOne, or where power receptacles are located in confined spaces.

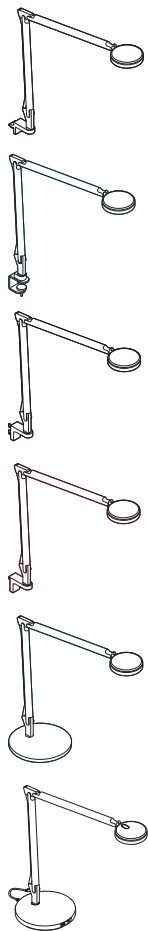

Standard Includes		Required to Specify
<ul style="list-style-type: none"> ▶ See <i>Worktools Specification Guide</i> for product details. 	<ul style="list-style-type: none"> • Task light and mounting bracket: paint price group 1 • 9.3-watt LED 3500K • Continuous range dimmer • 15-watt, 9' black power supply • 60-watt, 11' black modular power supply, if USB base is selected • Two integrated USB charging ports (type-A and type-C), if freestanding USB is selected • Integrated SOTO rail bracket, if selected 	<ol style="list-style-type: none"> 1 Style number 2 Paint color number for light: <ul style="list-style-type: none"> 4231 Arctic White 4710 Low Gloss Black 4799 Platinum Metallic 3 Options, if selected (see below) <ul style="list-style-type: none"> ▶ See <i>Surface Materials</i>, page 480.

Options	Required to Specify
Rail Bracket <ul style="list-style-type: none"> • Elective Elements Tech Zone bracket 	Specify with <i>EE Tech Zone</i> bracket.

Specification Information				
Dimensions			Weight	Style Number
D	W	H		
:	:	:	:	:

Rail-Mounted				
37"	3/4"	24 1/4"	1.7 lb	LDASHR
:	:	:	:	:

C-Clamp Mount				
37"	3/4"	24 1/4"	2.2 lb	LDASHC
:	:	:	:	:

Panel-Mounted For Use with Answer and Kick				
37"	3/4"	24 1/4"	2 lb	LDASHP
:	:	:	:	:

Slatwall- and SlatRail-Mounted				
37"	3/4"	24 1/4"	2 lb	LDASHS
:	:	:	:	:

Freestanding				
37"	8 1/4"	25"	9.65 lb	LDASHF
:	:	:	:	:

Freestanding USB				
37"	8 1/4"	25 1/4"	9.65 lb	LDASHU
:	:	:	:	:

Tip: Applications that include a rail mounted dash to Elective Elements Tech Zone will need to choose the optional Elective Elements Tech Zone rail mount bracket. Elective Elements Tech Zone rail mount bracket cannot be used with privacy screens, Slatwall, or FrameOne center screens. The light must be mounted adjacent to the screens or Slatwall.

dash LED Lights

With Occupancy Sensor

Tip: For applications that include an integrated SOTO rail: Ology, FrameOne, Campfire, Tour, or SOTO rail; specify dash rail mount with integrated SOTO bracket. dash can be mounted in front of privacy screens, Slatwall, or FrameOne center screen.

Tip: 90° mini extension cord can be used with Ology bench, FrameOne, or where power receptacles are located in confined spaces.

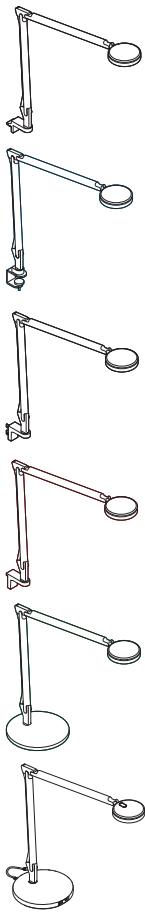

Standard Includes		Required to Specify
<ul style="list-style-type: none"> ▶ See <i>Worktools Specification Guide</i> for product details. 	<ul style="list-style-type: none"> • Task light and mounting bracket: paint price group 1 • Occupancy sensor • 9.3-watt LED 3500K • Continuous range dimmer • 15-watt, 9' black power supply • 60-watt, 11' black modular power supply, if USB base is selected • Two integrated USB charging ports (type-A and type-C), if freestanding USB is selected • Integrated SOTO rail bracket, if selected 	<ol style="list-style-type: none"> 1 Style number 2 Paint color number for light: <ul style="list-style-type: none"> 4231 Arctic White 4710 Low Gloss Black 4799 Platinum Metallic 3 Options, if selected (see below) <ul style="list-style-type: none"> ▶ See <i>Surface Materials</i>, page 480.

Options	Required to Specify
Rail Bracket <ul style="list-style-type: none"> • Elective Elements Tech Zone bracket 	Specify with <i>EE Tech Zone</i> bracket.

Specification Information

Dimensions			Weight	Style Number
D	W	H		
:	:	:	:	:

Rail-Mounted

37"	3/4"	24 1/4"	1.7 lb	LDASHOR
:	:	:	:	:

C-Clamp Mount

37"	3/4"	24 1/4"	2.2 lb	LDASHOC
:	:	:	:	:

Panel-Mounted For Use with Answer and Kick

37"	3/4"	24 1/4"	2 lb	LDASHOP
:	:	:	:	:

Slatwall- and SlatRail-Mounted

37"	3/4"	24 1/4"	2 lb	LDASHOS
:	:	:	:	:

Freestanding

37"	8 1/4"	25"	9.65 lb	LDASHOF
:	:	:	:	:

Freestanding USB

37"	8 1/4"	25 1/4"	9.65 lb	LDASHOU
:	:	:	:	:

Tip: Applications that include a rail mounted dash to Elective Elements Tech Zone will need to choose the optional Elective Elements Tech Zone rail mount bracket. Elective Elements Tech Zone rail mount bracket cannot be used with privacy screens, Slatwall, or FrameOne center screens. The light must be mounted adjacent to the screens or Slatwall.

Tip: For applications that include an integrated SOTO rail: Ology, FrameOne, Campfire, Tour, or SOTO rail; specify dash rail mount with integrated SOTO bracket. dash can be mounted in front of privacy screens, Slatwall, or FrameOne center screen.

Tip: 90° mini extension cord can be used with Ology bench, FrameOne, or where power receptacles are located in confined spaces.

Standard Includes		Required to Specify
<ul style="list-style-type: none"> ▶ See <i>Worktools Specification Guide</i> for product details. 	<ul style="list-style-type: none"> • Task light and mounting bracket: paint price group 1 • 9.3-watt LED 3500K • Continuous range dimmer • 15-watt, 9' black power supply • 60-watt, 11' black modular power supply, if USB base is selected • Two integrated USB charging ports (type-A and type-C), if freestanding USB is selected • Integrated SOTO rail bracket, if selected 	<ul style="list-style-type: none"> 1 Style number 2 Paint color number for light: <ul style="list-style-type: none"> 4231 Arctic White 4710 Low Gloss Black 4799 Platinum Metallic 3 Options, if selected (see below) <ul style="list-style-type: none"> ▶ See <i>Surface Materials</i>, page 480.

Options	Required to Specify
Rail Bracket <ul style="list-style-type: none"> • Elective Elements Tech Zone bracket 	Specify with <i>EE Tech Zone</i> bracket.

Specification Information

Dimensions			Weight	Style Number
D	W	H		

Rail-Mounted				
24"	3/4"	20 3/8"	1.3 lb	LDASHMINIR

C-Clamp Mount				
24"	3/4"	20 3/8"	1.8 lb	LDASHMINIC

Panel-Mounted For Use with Answer and Kick				
24"	3/4"	20 3/8"	1.6 lb	LDASHMINIP

Slatwall- and SlatRail-Mounted				
24"	3/4"	20 3/8"	1.6 lb	LDASHMINIS

Freestanding				
24"	8 1/4"	21 1/10"	9.25 lb	LDASHMINIF

Freestanding USB				
24"	8 1/4"	21 7/10"	9.25 lb	LDASHMINIU

Tip: Applications that include a rail mounted dash to Elective Elements Tech Zone will need to choose the optional Elective Elements Tech Zone rail mount bracket. Elective Elements Tech Zone rail mount bracket cannot be used with privacy screens, Slatwall, or FrameOne center screens. The light must be mounted adjacent to the screens or Slatwall.

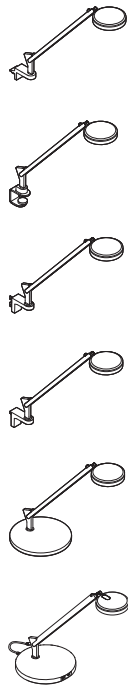

dash mini LED Lights

With Occupancy Sensor

Tip: For applications that include an integrated SOTO rail: Ology, FrameOne, Campfire, Tour, or SOTO rail; specify dash rail mount with integrated SOTO bracket. dash can be mounted in front of privacy screens, Slatwall, or FrameOne center screen.

Tip: 90° mini extension cord can be used with Ology bench, FrameOne, or where power receptacles are located in confined spaces.

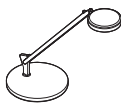

Tip: Applications that include a rail mounted dash to Elective Elements Tech Zone will need to choose the optional Elective Elements Tech Zone rail mount bracket. Elective Elements Tech Zone rail mount bracket cannot be used with privacy screens, Slatwall, or FrameOne center screens. The light must be mounted adjacent to the screens or Slatwall.

Standard Includes	Required to Specify
<ul style="list-style-type: none"> ▶ See <i>Worktools Specification Guide</i> for product details. • Task light and mounting bracket: paint price group 1 • 9.3-watt LED 3500K • Continuous range dimmer • 15-watt, 9' black power supply • 60-watt, 11' black modular power supply, if USB base is selected • Two integrated USB charging ports (type-A and type-C), if freestanding USB is selected • Occupancy sensor • Integrated SOTO rail bracket, if selected 	<ul style="list-style-type: none"> 1 Style number 2 Paint color number for light: <ul style="list-style-type: none"> 4231 Arctic White 4710 Low Gloss Black 4799 Platinum Metallic 3 Options, if selected (see below) <ul style="list-style-type: none"> ▶ See <i>Surface Materials</i>, page 480

Options	Required to Specify
Rail Bracket <ul style="list-style-type: none"> • Elective Elements Tech Zone bracket 	Specify with <i>EE Tech Zone</i> bracket.

Specification Information

Dimensions	Weight	Style Number
D	W	H

Rail-Mounted		
24"	3/4"	20 3/8"
		1.3 lb
		LDASHMINIOR

C-Clamp Mount		
24"	3/4"	20 3/8"
		1.8 lb
		LDASHMINIOC

Panel-Mounted For Use with Answer and Kick		
24"	3/4"	20 3/8"
		1.6 lb
		LDASHMINIOP

Slatwall- and SlatRail-Mounted		
24"	3/4"	20 3/8"
		1.6 lb
		LDASHMINIOS

Freestanding		
24"	8 1/4"	21 1/10"
		9.25 lb
		LDASHMINIOF

Freestanding USB		
24"	8 1/4"	21 7/10"
		9.25 lb
		LDASHMINIOU

Standard Includes		Required to Specify
<ul style="list-style-type: none"> ▶ See <i>Worktools Specification Guide</i> for product details. 	<ul style="list-style-type: none"> • Task light and mounting bracket: paint price group 1 • 18-watt power supply with 9' black cord with 3' silver cord with quick connector • Continuous range dimmer • Automatic turn off program • 7.5-watt LED 3500K 	<ol style="list-style-type: none"> 1 Style number 2 Paint color number for light: <ul style="list-style-type: none"> 4231 Arctic White 4710 Low Gloss Black 4799 Platinum Metallic 3 Options, if selected (see below) <ul style="list-style-type: none"> ▶ See <i>Surface Materials</i>, page 480.

Options		Required to Specify
Occupancy Sensor	<ul style="list-style-type: none"> • With occupancy sensor 	Specify with <i>occupancy sensor</i> .
Base/Mounting Brackets	<ul style="list-style-type: none"> • Freestanding base • C-clamp mount bracket • Slatwall mount bracket • Integrated rail-mount bracket • Panel-mount bracket • Through-mount bracket • Theft deterrent through-mount bracket • Freestanding base with USB 	Specify with <i>freestanding base</i> . Specify with <i>C-clamp mount bracket</i> . Specify with <i>Slatwall mount bracket</i> . Specify with <i>integrated rail-mount bracket</i> . Specify with <i>panel-mount bracket</i> . Specify with <i>through-mount bracket</i> . Specify with <i>theft deterrent through-mount bracket</i> . Specify with <i>freestanding base with USB</i> .

Tip: Through-mount and theft deterrent through-mount brackets can only be used with worksurfaces that are 1" to 1¾" thick. They are not for use with Bivi or FrameOne worksurfaces under 1"D.



Specification Information

Dimensions			Style Number
D	W	H	
:	:	:	:

LED Radial Single Arm Light

13"	6"	16½"	LLRDS
:	:	:	:

LED Radial Double Arm Light

20½"	6"	21½"	LLRDD
:	:	:	:

LED Linear Desktop Lights

Standard Includes		Required to Specify
<ul style="list-style-type: none"> ▶ See <i>Worktools Specification Guide</i> for product details. 	<ul style="list-style-type: none"> • Task light and mounting bracket: paint price group 1 • 18-watt power supply with 9' black cord with 3' silver cord with quick connector • Continuous range dimmer • Automatic turn off program • 7.5-watt LED 3500K 	<ul style="list-style-type: none"> 1 Style number 2 Paint color number for light: <ul style="list-style-type: none"> 4231 Arctic White 4710 Low Gloss Black 4799 Platinum Metallic 3 Options, if selected (see below) <ul style="list-style-type: none"> ▶ See <i>Surface Materials</i>, page 480

Options		Required to Specify
Occupancy Sensor	<ul style="list-style-type: none"> • With occupancy sensor 	Specify with <i>occupancy sensor</i> .
Base/Mounting Brackets	<ul style="list-style-type: none"> • Freestanding base • C-clamp mount bracket • Slatwall-mount bracket • Integrated rail-mount bracket • Panel-mount bracket • Through-mount bracket • Theft deterrent through-mount bracket • Freestanding base with USB 	<ul style="list-style-type: none"> Specify with <i>freestanding base</i>. Specify with <i>C-clamp mount bracket</i>. Specify with <i>Slatwall-mount bracket</i>. Specify with <i>integrated rail-mount bracket</i>. Specify with <i>panel-mount bracket</i>. Specify with <i>through-mount bracket</i>. Specify with <i>theft deterrent through-mount bracket</i>. Specify with <i>freestanding base with USB</i>.

Tip: Through-mount and theft deterrent through-mount brackets can only be used with worksurfaces that are 1" to 1 3/4" thick. They are not for use with Bivi or FrameOne worksurfaces under 1"D.

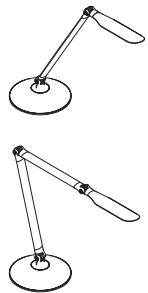

Specification Information			
Dimensions			Style
D	W	H	Number
:	:	:	:
:	:	:	:

LED Linear Single Arm Light

15"	6"	16 1/2"	LLLDS
:	:	:	:

LED Linear Double Arm Light

22 1/2"	6"	21 1/2"	LLLDD
:	:	:	:

Tip: Power cord length is 75". Consider distance from light to power receptacle, and if surface or under the worksurface power receptacle may be needed. Applies to both single-arm and double-arm lights.

Standard Includes	Required to Specify
-------------------	---------------------

- | | | |
|---|---|--|
| <ul style="list-style-type: none"> ▶ See <i>Worktools Specification Guide</i> for product details. | <ul style="list-style-type: none"> • Task light and freestanding base: paint price group 1 • 75" cord two-prong power supply • LED light source • Capacitive switch • Three-step dimming • 7W LED 3000K | <ul style="list-style-type: none"> 1 Style number 2 Paint color number for light: <ul style="list-style-type: none"> 4135 Black Matte 4142 Platinum Gloss |
|---|---|--|

Specification Information			
---------------------------	--	--	--

• Dimensions			• Style
D	W	H	Number

LED Intro Single-Arm Task Light

7"	7"	18 ³ / ₁₀ "	LSCTSKLIGHT1
:	:	:	:

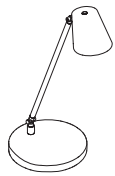

LED Intro Double-Arm Task Light

7"	7"	17 ³ / ₄ "	LSCTSKLIGHT2
:	:	:	:

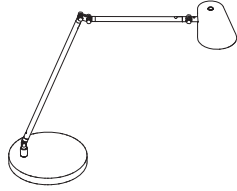

LED Shelf Lights

Tip: Maximum number of lights that can be daisy chained is three lights.

Standard Includes		Required to Specify
<ul style="list-style-type: none"> ▶ See <i>Worktools Specification Guide</i> for product details. 	<ul style="list-style-type: none"> Aluminum extrusion with plastic cover Power supply with cord Soft touch switch Thin profile accommodates recessed and low profile flush mounting Ultra energy efficient LED light source Universal magnetic mounting Polycarbonate matte film diffuser Continuous dimming 	<ul style="list-style-type: none"> 1 Style number 2 Plastic color number for cover: <ul style="list-style-type: none"> 6000 Black 6009 Arctic White 3 Options, if selected (see below)

Options	Required to Specify
Mounting <ul style="list-style-type: none"> Fastener kit for use with wood shelf 	Specify <i>with fastener kit</i> .

Specification Information

Dimensions			Lamp Wattage	Style Number
D	W	H		
2 1/2"	18"	1/2"	9.6 watts	LSL18

LED Standard Light

2 1/2"	18"	1/2"	9.6 watts	LSL18
--------	-----	------	-----------	-------

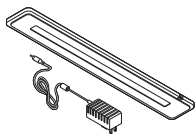

Tip: LED standard light comes with a 9' 18 watt power supply.

LED Daisy Chain Starter Light

2 1/2"	18"	1/2"	9.6 watts	LSL18YA
--------	-----	------	-----------	---------

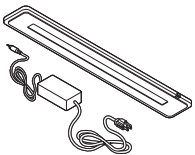

Tip: Daisy chain starter light comes with a 65 watt power supply that will support up to three lights in series (11' cord; 6' from power supply to power outlet, 5' from power supply to fixture). Does not include daisy chain jumper cords.

LED Daisy Chain Secondary Light

2 1/2"	18"	1/2"	9.6 watts	LSL18YB
--------	-----	------	-----------	---------

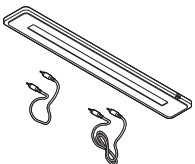

Tip: Daisy chain secondary light does not come with a power supply. Daisy chain cord package (8" and 30") comes standard with each secondary light.

Standard Shelf Lights X 10/26

Tip: Daisy chaining shelf lights together extends power from one fixture to another within workstations to help keep receptacles clear for other uses.

Tip: Daisy chaining is not allowed in Chicago. Local electrical codes vary, so you should consult a qualified electrical contractor or engineer for proper installation of all electrical equipment.

Tip: Because shelf lights are usually recessed, black is the standard paint color.

Tip: If an optional paint color is selected for the housing, the electrical switches and end caps will remain black plastic.

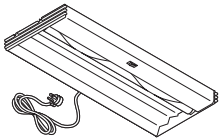

Tip: When ordering with standard power cord or Chicago cord, daisy chaining is not possible.

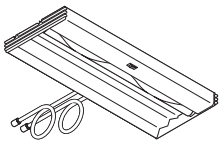

Tip: Remember to order a daisy chain starter cord separately.

▶ See Related Products on next page.

Standard Includes		Required to Specify
▶ See <i>Worktools Specification Guide</i> for product details.	<ul style="list-style-type: none"> Light housing with centered on-off switch: black paint End cap cord managers: black plastic only Cords: <ul style="list-style-type: none"> — Standard and Chicago (including circuit breaker), 9' cord with three-prong plug at 45° angle: black plastic only — Daisy chain, one 78" cord with modular connectors for daisy chaining: black plastic only Contrast sleeve around lamp Faceted reflector: white only T8 3500K lamp Ballast Universal mounting hardware package Daisy chain starter cord, if selected: black plastic only (order separately) 	1 Style number 2 Paint color number, if other than black (see options below) 3 Options, if selected (see below) ▶ See <i>Surface Materials</i> , page 480.

Options		Required to Specify
Surface Materials	<ul style="list-style-type: none"> Painted light housing other than black 	Specify paint color number for housing.
Bracket Option	<ul style="list-style-type: none"> Competitive mounting package Flush mounting package 	Specify <i>with competitive mounting package</i> . Specify <i>with flush mounting package</i> and paint color number for end cap covers.

Specification Information					
Dimensions			Lamp	Style	
D	W	H	Wattage	Number	

Electronic High-Power-Factor Ballast

With Standard Power Cord

9¼"	25"	1¾"	17 watts	LSM24K X 10/26
9¼"	37"	1¾"	25 watts	LSM36K X 10/26
9¼"	49"	1¾"	32 watts	LSM48K X 10/26

With Chicago Cord Including Circuit Breaker

9¼"	25"	1¾"	17 watts	LSM24KC X 10/26
9¼"	37"	1¾"	25 watts	LSM36KC X 10/26
9¼"	49"	1¾"	32 watts	LSM48KC X 10/26

With Daisy Chain Cords

9¼"	25"	1¾"	17 watts	LSM24KD X 10/26
9¼"	37"	1¾"	25 watts	LSM36KD X 10/26
9¼"	49"	1¾"	32 watts	LSM48KD X 10/26

▶ **Specification Information, continued on next page**

X 10/26 = Last order entry
October 18, 2026

► Specification Information, continued from previous page

Related Products

Quantity in Package	Length	Style Number
---------------------	--------	--------------

Daisy Chain Starter Cord

1	78"	LS1FSC ❌10/26
6	78"	LS6FSC ❌10/26
:	:	:

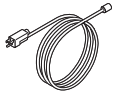

Tip: Use with Standard shelf light with daisy chain cord only.

❌10/26 = Last order entry
October 18, 2026

LED Linear Shelf Lights

Tip: The power supply for the 17" stand alone only uses a straight plug with a 9' 18 watt 24 volt wall transformer. The power supply for the 31", 44", 58", or 17" starter light uses a 11' 65 watt compact in-line brick with straight plug.

Tip: Cord exists on ends of light fixture. Allow 1³/₄" cord bend radius. With optional occupancy sensor, add 4³/₄".

Standard Includes		Required to Specify
<ul style="list-style-type: none"> See <i>Worktools Specification Guide</i> for product details. 	<ul style="list-style-type: none"> Task light and mounting bracket: 4231 Arctic White Power supply with cord: black Soft touch switch Magnetic and wood mounting brackets Continuous range dimmer Automatic turn off program Color temperature 3500K 	<ul style="list-style-type: none"> 1 Style number 2 Options, if selected (see below)
Options		Required to Specify
Surface Materials	<ul style="list-style-type: none"> Painted light housing in 0835 Black 	Specify with 0835 Black.
Occupancy Sensor	<ul style="list-style-type: none"> 17"W, 31"W, 44"W, and 58"W with stand alone or daisy chain starter 	Specify with occupancy sensor.
High Output	<ul style="list-style-type: none"> 17"W with stand alone, starter, or secondary 31"W, 44"W, and 58"W with stand alone or daisy chain starter, or secondary 	Specify with high output.

Specification Information			
Dimensions			Style
D	W	H	Number

17" Stand Alone Light

2"	17"	7/10"	LLL17
:	:	:	:

17" Daisy Chain Starter Light

2"	17"	7/10"	LLL17YA
:	:	:	:

17" Daisy Chain Secondary Light

2"	17"	7/10"	LLL17YB
:	:	:	:

31" Stand Alone or Daisy Chain Starter Light

2"	31"	7/10"	LLL31
:	:	:	:

31" Daisy Chain Secondary Light

2"	31"	7/10"	LLL31YB
:	:	:	:

► **Specification Information, continued on next page**

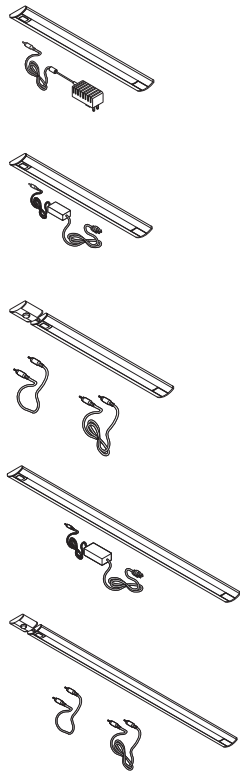

► Specification Information, continued from previous page

Specification Information

• Dimensions			• Style
D	W	H	Number

44" Stand Alone or Daisy Chain Starter Light

2"	44"	7/10"	LLL44
----	-----	-------	--------------

44" Daisy Chain Secondary Light

2"	44"	7/10"	LLL44YB
----	-----	-------	----------------

58" Stand Alone or Daisy Chain Starter Light

2"	58"	7/10"	LLL58
----	-----	-------	--------------

58" Daisy Chain Secondary Light

2"	58"	7/10"	LLL58YB
----	-----	-------	----------------

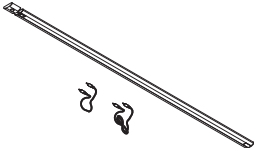
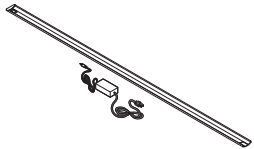
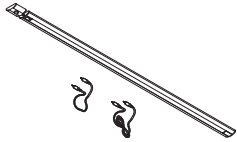
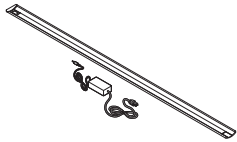

Tip: Cord exists on ends of light fixture. Allow 1 3/4" cord bend radius. With optional occupancy sensor, add 4 3/4".

Bottomline Shelf Light

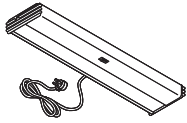

Tip: Daisy chaining shelf lights together extends power from one fixture to another within workstations to help keep receptacles clear for other uses.













Tip: Daisy chaining is not allowed in Chicago. Local electrical codes vary, so you should consult a qualified electrical contractor or engineer for proper installation of all electrical equipment.

Tip: When ordering with standard power cord or Chicago cord, daisy chaining is not possible.

Tip: When ordering the Bottomline shelf lights with daisy chain starter cord you do NOT need to order a starter cord or jumper cord.

Standard Includes	Required to Specify
<ul style="list-style-type: none"> ▶ See <i>Worktools Specification Guide</i> for product details. • Steel light housing: paint • Mylar reflector • Batwing lens • Polycarbonate end caps: molded to match housing • Cords: <ul style="list-style-type: none"> — Standard and Chicago (including circuit breaker), 9' cord with three-prong plug at 45° angle: black plastic only — Daisy chain, one 56" cord with modular connectors for daisy chaining: black plastic only • Energy efficient electronic ballast • Energy efficient 3500K T5 fluorescent light • Universal spring brackets for recessed mount and screw-in for flush mount • Tool free clips for New York application 	<ul style="list-style-type: none"> 1 Style number 2 Paint color number for housing and end caps: <ul style="list-style-type: none"> 0835 Black 7018 Pewter

Specification Information

Dimensions			Lamp Wattage	Style Number
D	W	H		
With Standard Power Cord				
4½"	23¼"	1¼"	14 watts	L52FT 
4½"	35"	1¼"	21 watts	L53FT 
4½"	46¾"	1¼"	28 watts	L54FT 
With Chicago Cord Including Circuit Breaker				
4½"	23¼"	1¼"	14 watts	L52FTCHI 
4½"	35"	1¼"	21 watts	L53FTCHI 
4½"	46¾"	1¼"	28 watts	L54FTCHI 
With Daisy Chain Cord				
4½"	23¼"	1¼"	14 watts	L52FTY 
4½"	35"	1¼"	21 watts	L53FTY 
4½"	46¾"	1¼"	28 watts	L54FTY 
With Daisy Chain Starter Cord				
4½"	23¼"	1¼"	14 watts	L52FTS 
4½"	35"	1¼"	21 watts	L53FTS 
4½"	46¾"	1¼"	28 watts	L54FTS 

Specification Guidelines

Application	Requirement
2 lights	1 starter fixture and 1 daisy chain fixture
3 lights	1 starter fixture and 2 daisy chain fixtures
4 lights	1 starter fixture and 3 daisy chain fixtures
5 lights	1 starter fixture and 4 daisy chain fixtures
6 lights	1 starter fixture and 5 daisy chain fixtures

Note: Daisy chaining minimum of two fixtures; maximum of six fixtures.

 = Last order entry
October 18, 2026

High-Capacity Cable Riser

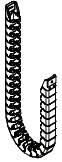

Tip: Screw attachment to the underside of the mounting surface.

Tip: Magnetic bottom bracket attaches to metal magnetic surface.

Tip: Do not use with integrated storage.

Tip: Do not use within an enclosed area that would restrict the movement of the cable riser's links.

Tip: Total weight is 1.2 pounds (without cords).

Standard Includes		Required to Specify
▶ See <i>Worktools Specification Guide</i> for product details.	<ul style="list-style-type: none"> High capacity vertical cable riser: plastic Attachment hardware for top bracket Magnetic bottom bracket 	1 Style number 2 Plastic color number for cable riser: 6053 Seagull 6527 Merle

Specification Information			
Dimensions			Style
D	W	L	Number
17/16"	131/32"	415/16"	DSVCMHC

Power and Cable Management

Vertical Cable Carrier



Tip: Vertical cable carrier is recommended for use with height-adjustable worksurfaces.

Tip: Vertical cable carrier affixes under the work surface and has a weighted base to hold it in place.

Standard Includes		Required to Specify
▶ See <i>Worktools Specification Guide</i> for product details.	<ul style="list-style-type: none"> Cable carrier: 6688 Steel Attachment hardware 	Style number

Specification Information		
Dimensions		Style
W	H	Number
21/2"	52"	AHCC

1 3/4"D Wire Managers

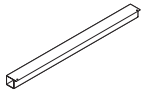

Standard Includes		Required to Specify
<ul style="list-style-type: none"> ▶ See <i>Worktools Specification Guide</i> for product details. 	<ul style="list-style-type: none"> • Wire manager: 6000 Black • Attachment hardware 	Style number

Specification Information				
Dimensions			Weight	Style Number
D	W	H		
1 3/4"	6"	1 3/4"	0.13 lb	AWM06
1 3/4"	12"	1 3/4"	0.24 lb	AWM12
1 3/4"	18"	1 3/4"	0.34 lb	AWM18
1 3/4"	23"	1 3/4"	0.44 lb	AWM23
1 3/4"	30"	1 3/4"	0.56 lb	AWM30
1 3/4"	35"	1 3/4"	0.65 lb	AWM35
1 3/4"	42"	1 3/4"	0.77 lb	AWM42
1 3/4"	48"	1 3/4"	0.88 lb	AWM48
:	:	:	:	:

Tip: Actual width of **AWM23** is 23 1/4".

Powerstrip Intro

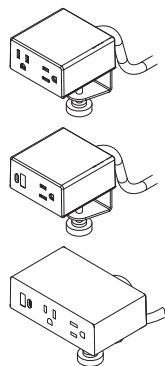

Tip: C-clamp is designed to accommodate worksurfaces up to 1 1/2" thick.

Tip: Each USB-A port can provide up to 10 watts (2 amps).

Tip: Overcurrent protection includes a 15 amp circuit breaker.

Tip: USB A+C 20W for charging cell phones, tablets, headphones, wearable fitness trackers, or other small electronic devices.

Tip: Optional under worksurface utility power blocks do not ship with independent mounting hardware. Designed to be used with the universal cable management kits. Kit sold separately.

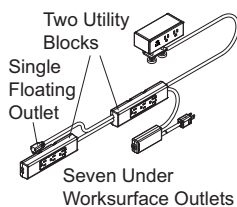
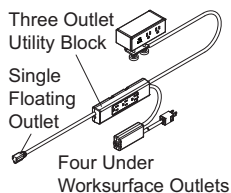

Tip: Specify 163" curly cord and 90° NEMA plug together and add additional cord management near the plug for a more secure power connection during desk movement.

Standard Includes	Required to Specify
<ul style="list-style-type: none"> ▶ See <i>Worktools Specification Guide</i> for product details. • Powerstrip intro: plastic • Straight 3-prong plug • C-clamp mount • Cord managers 	<ol style="list-style-type: none"> 1 Style number 2 Desktop power configuration (see below under Required Selections) 3 Plastic color number for housing: <ul style="list-style-type: none"> 6009 Arctic White 6527 Merle 4 Options, (if selected) see below

Required Selections	Required to Specify
Desktop Power Configuration <ul style="list-style-type: none"> • Two power outlets • One power outlet with one USB A+C 20W 	Specify with two power outlets. Specify with one power outlet with one USB A+C 20W.
<ul style="list-style-type: none"> • Two power outlets with one USB A+C 20W 	Specify with two power outlets with one USB A+C 20W.

Options	Required to Specify
Power Plug Type <ul style="list-style-type: none"> • Standard NEMA 3-prong • 90° NEMA with overcurrent protection (OCP, used when desktop power only is specified, no utility power) • 90° NEMA (No OCP, used when utility power option is specified) 	Specify with standard NEMA plug. Specify with 90° NEMA plug with overcurrent protection (OCP). Specify with 90° NEMA (no OCP).

Under Worksurface Utility Power Configuration <ul style="list-style-type: none"> • Four outlets total—one utility block, with three outlets each, and one floating female outlet • Seven outlets total—two utility blocks, with three outlets each, and one floating female outlet 	Specify with one utility and one female plug. Specify with two utility and one female plug.
---	--

Power Cord Lengths Without Under Worksurface Utility Power <ul style="list-style-type: none"> • 9' standard • 163" curly cord 	Specify with 9' standard cord. Specify with 163" curly cord.
--	---

Power Cord Lengths With Under Worksurface Utility Power <ul style="list-style-type: none"> • 6' standard • 8' standard • 163" curly cord 	Specify with 6' standard cord. Specify with 8' standard cord. Specify with 163" curly cord.
--	---

Specification Information				
Dimensions			Style Number	
D	W	H		
3"	3"	3 1/8"	DSPINTRO	

Tip: Cord clip screw length for minimum worksurface thickness of 3/4".

Powerstrip Plus



C-clamp

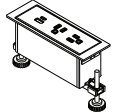

Flush mount

Tip: C-clamp is designed to accommodate worksurfaces between 1/2" and 1 3/8" thick.

Tip: Desktop power cord exit extends 1/2" off of the back of the worksurface when C-clamped.

Tip: Cord length between desktop power and under worksurface power is 48" and length between under worksurface blocks is 24".

Tip: Cord clip screw length for minimum worksurface thickness of 3/4".

Tip: Flush mount requires top surface to be field cut. See assembly directions for details.

Tip: Flush mount faceplate mounts flat just above worksurface.

Tip: Under worksurface power blocks do not ship with independent mounting hardware. They are designed to mount into the Universal cable management kit without additional hardware. Kit sold separately.

Tip: Overcurrent protection includes a 15 amp circuit breaker.

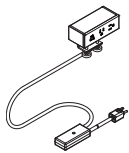

With overcurrent protection

Standard Includes		Required to Specify
<ul style="list-style-type: none"> ▶ See <i>Worktools Specification Guide</i> for product details. 	<ul style="list-style-type: none"> • Powerstrip plus: plastic price group 1 • 8' standard power cord: black or white • C-clamp mount • Cord managers 	<ol style="list-style-type: none"> 1 Style number 2 Desktop power mount (see below under Required Selections) 3 Desktop power configuration (see below under Required Selections) 4 Plastic color number for powerstrip 5 Plastic color number for power cord 6 Options, (if selected) see below <ul style="list-style-type: none"> ▶ See <i>Surface Materials</i>, page 480.

	Required Selections	Required to Specify
Desktop Power Mount	<ul style="list-style-type: none"> • C-clamp • Front edge under mount • Rail mount • Flush mount 	<p>Specify with <i>C-clamp power mount</i>. Specify with <i>front-edge under mount</i>. Specify with <i>rail power mount</i>. Specify with <i>flush mount</i>.</p>
Desktop Power Configuration	<ul style="list-style-type: none"> • Two power outlets with USB A+C 20-watt • Three power outlets with USB A+C 20W 	<p>Specify with <i>two power outlets with USB A+C 20-watt</i>. Specify with <i>three power outlets with USB A+C 20W</i>.</p>
Flush mount only	<ul style="list-style-type: none"> • Two power outlets and open data port • One power outlet with 100-watt USB-C 	<p>Specify with <i>two power outlets and open data port</i>. Specify with <i>one power outlet 100-watt USB-C</i>.</p>

	Options	Required to Specify
Under Worksurface (Utility) Power Configuration	<ul style="list-style-type: none"> • No under worksurface with overcurrent protection 	Specify with <i>no utility and with overcurrent protection</i> .
Power Cord	<ul style="list-style-type: none"> • 6' standard cord 	Specify with <i>6' standard cord</i> .
Power Cord Color	<p>Standard cord</p> <ul style="list-style-type: none"> • Black • White 	Specify with <i>black cord</i> . Specify with <i>white cord</i> .
Power Plug Type	<ul style="list-style-type: none"> • Standard NEMA 3-prong • 90° NEMA • Thread low profile 	Specify with <i>standard NEMA plug</i> . Specify with <i>90° NEMA plug</i> . Specify with <i>Thread low profile plug</i> .

Tip: Local electrical codes vary, so consult with your local authority having jurisdiction as they have final say if the products as installed are compliant with local code.

Tip: Height-adjustable desks can be plugged into powerstrip's utility power for a one cord down solution.

Specification Information

• **Style
Number**

DSPOWER



C-clamp

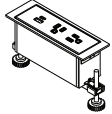

Flush mount

SW_1 PowerPod

DESIGN SCOTT WILSON & MINIMAL

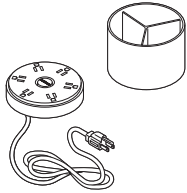

Tip: PowerPod must be plugged directly into the building power supply.

Standard Includes

- ▶ See *Coalesse Tables, Storage, and Accessories Specification Guide* for product details.
- PowerPod with 6' cord and three prong plug: brushed aluminum bottom cradle and milk face
- Accessory tray: milk
- Six 15-amp power outlets
- Illuminated on/off button
- Surge suppressor

Required to Specify

Style number

Specification Information

Dimensions		Style
Diameter	H	Number
6¾"	6"	COPP01

CF Intro Single

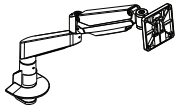

Tip: **CFINTRO** supports 2.2-20 lb. per monitor.

Tip: **CF Standard Tilt head** and **CF Universal Slider bar** tilt heads are standard with quick release.

Standard Includes	Required to Specify
<ul style="list-style-type: none"> See <i>Worktools Specification Guide</i> for product details. Monitor arm: paint Standard tilt head with quick release 	<ol style="list-style-type: none"> Style number Paint color number for monitor arm: <ul style="list-style-type: none"> 0835 Black 7018 Pewter ZW01 Pearl Snow Options, if selected (see below)

Options	Required to Specify
Tilt head mechanism <ul style="list-style-type: none"> CF standard tilt head CF universal slider bar tilt head 	Specify with <i>CF standard tilt head</i> . Specify with <i>CF slider bar tilt head</i> .
Brackets <ul style="list-style-type: none"> No bracket CF C-clamp CF through mount 	Specify with <i>no bracket</i> . Specify with <i>CF C-clamp</i> . Specify with <i>CF through mount</i> .

Specification Information	
Weight	Style Number
7.6 lb	CFINTRO

Monitor Arms

CF Intro Dual

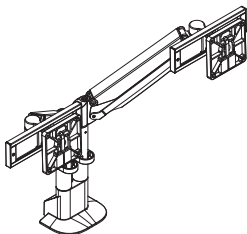

Tip: **CFINTRODSLIDE** supports 2.2–20 lb per monitor.

Tip: **CFINTRODSLIDE** is standard with two **CF standard slider bar** tilt heads.

Tip: **CFINTRODSLIDE** is not recommended for corner applications.

Standard Includes	Required to Specify
<ul style="list-style-type: none"> See <i>Worktools Specification Guide</i> for product details. Monitor arm: paint CF standard tilt head with quick release 	<ol style="list-style-type: none"> Style number Paint color number for monitor arm: <ul style="list-style-type: none"> 0835 Black 7018 Pewter ZW01 Pearl Snow Options, if selected (see below)

Options	Required to Specify
Brackets <ul style="list-style-type: none"> CF dual C-clamp CF dual through mount 	Specify with <i>CF dual C-clamp</i> . Specify with <i>CF dual through mount</i> .

Specification Information	
Weight	Style Number
13.65 lb	CFINTRODSLIDE

CF Tablet and Laptop Holders

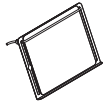

Tip: Laptop holder includes black pad to stop laptop slippage. Security cord secures laptop in place.

Tip: Laptop holder and universal laptop/tablet holder attach to tilt head mechanism (not included).

Tip: The laptop holder platform (CFLHS) can be used on CF monitor arms, as well as most monitor arms with a VESA plate and tilt head that has tilt functionality.

Tip: Please mockup when ordering CF laptop holder to ensure it meets mobility expectations.

Tip: CF slider bar will limit the mobility of the laptop holder to approximately 45 degrees. For best mobility, make sure the attached arm does not have a slide bar.

Standard Includes	Required to Specify
-------------------	---------------------

<ul style="list-style-type: none"> ▶ See <i>Worktools Specification Guide</i> for product details. • Laptop holder, if selected: paint 	<ul style="list-style-type: none"> 1 Style number 2 Paint color number for laptop holder, if selected: <ul style="list-style-type: none"> 0835 Black 7018 Pewter ZW01 Pearl Snow
--	--

Specification Information		
Dimensions		Style
D	W	Number

10"	13½"	CFLHS
-----	------	-------

CF Arm Connector



Standard Includes	Required to Specify
-------------------	---------------------

<ul style="list-style-type: none"> ▶ See <i>Worktools Specification Guide</i> for product details. • Bracket: paint • Inserts to attach arm extensions and hardware 	<ul style="list-style-type: none"> 1 Style number 2 Paint color number for bracket: <ul style="list-style-type: none"> 0835 Black 7018 Pewter ZW01 Pearl Snow
--	---

Specification Information
Style
Number

CFMSC

Tip: CFMSC connectors are included with CF Plus and Plus HD when single pole options are specified in assembly.

Tip: CF Plus and Plus heavy-duty dynamic arms are compatible with CFMSC.

CF Flat Panel Monitor Bracket



*Tip: **CFSERIESCC** does not work in an Ology integrated rail application.*

Tip: Flat panel monitor arm must be used with flat panel monitor brackets, ordered separately.

Tip: When mounting CF arm brackets to Slatwall, bracket must be mounted no further than 10" away from Slatwall mounting bracket. If application does not allow bracket to be installed within the 10" range, an additional bracket or brackets should be installed within 10" of desired arm location.

Standard Includes	Required to Specify
<ul style="list-style-type: none"> ▶ See <i>Worktools Specification Guide</i> for product details. • Bracket: paint 	<ul style="list-style-type: none"> 1 Style number 2 Paint color number for bracket: <ul style="list-style-type: none"> 0835 Black 7018 Pewter ZW01 Pearl Snow

Specification Information	
• Weight	• Style Number
:	:
:	:

CF C-Clamp

4 lb	CFSERIESCC
:	:

Monitor Arms

CF Brackets

Tip: Flat panel monitor arm must be used with flat panel monitor brackets, ordered separately.

Tip: When mounting CF arm brackets to Slatwall, bracket must be mounted no further than 10" away from Slatwall mounting bracket. If application does not allow bracket to be installed within the 10" range, an additional bracket or brackets should be installed within 10" of desired arm location.

Standard Includes	Required to Specify
<ul style="list-style-type: none"> ▶ See <i>Worktools Specification Guide</i> for product details. • Bracket: paint 	<ul style="list-style-type: none"> 1 Style number 2 Paint color number for bracket: <ul style="list-style-type: none"> 0835 Black 7018 Pewter ZW01 Pearl Snow

Specification Information	
• Weight	• Style Number
:	:
:	:

Wall/Reverse Wall-Mount Bracket

2.5 lb	CFSPWM
:	:



*Tip: **CFSPWM** is not recommended for drywall, sheet rock, or plaster surfaces.*

Slatwall Bracket

3 lb	CFSPSW
:	:



*Tip: When using **CFSPSW**, limit the CF arm load to 25 lb.*

CF Monitor Arm Adapters and Tilt Heads

Tip: Use the adjustable monitor adapter with standard tilt head mechanism to add more vertical movement on the CF pole system triple assemblies.

Tip: **CFTHSLIDEWO** and **CFTHSLIDEHD** can be used with CF pole mounted solutions.

Tip: **CFHDTH** and **CFHDQRTH2** can be used with both CF Plus and CF Plus heavy-duty.



Tip: To adjust the monitor height up and down using a static pole, specify the adjustable monitor arm adapter.

Tip: When using curved screens greater than 32" or if your monitor weighs over 30 lb, use CF heavy-duty tilt head (**CFHDTH** or **CFHDQRTH2**).



Standard Includes	Required to Specify
<ul style="list-style-type: none"> ▶ See <i>Worktools Specification Guide</i> for product details. • Tilt head: paint • Adjustable monitor adapter without tilt head mechanism: black paint only • Tilt head mechanism with VESA plate, if selected 	<ul style="list-style-type: none"> 1 Style number 2 Paint color number for tilt head: <ul style="list-style-type: none"> 0835 Black 7018 Pewter ZW01 Pearl Snow

Specification Information

• **Style Number**

Adjustable Monitor Adapter without Tilt Head Mechanism

CFTHSLIDEWO

Adjustable Monitor Adapter with Standard Tilt Head Mechanism

CFTHSLIDE

Adjustable Monitor Adapter with Heavy-Duty Tilt Head Mechanism

CFTHSLIDEHD

CF Articulating Arm Extensions for Pole Mount Assemblies



Tip: CF arm extensions are interchangeable and retrofitable. Arm extensions support larger monitors.

Tip: Tilt head is not included with the extension arm. Must order tilt heads separately.

Tip: **CFXP4H, CFXP8H,** and **CFXP12H** can be used with CF Plus, CF Plus heavy-duty, and static monitor arms.

Tip: For Ology bench with integrated rail, specify CF C-clamp.

Tip: Horizontal extenders are not compatible to work directly with **CFDC**.

Standard Includes	Required to Specify
<ul style="list-style-type: none"> See <i>Worktools Specification Guide</i> for product details. Articulating extension arm: paint 	<ul style="list-style-type: none"> 1 Style number 2 Paint color number for extender: <ul style="list-style-type: none"> 0835 Black 7018 Pewter ZW01 Pearl Snow

Specification Information	
Weight	Style Number
0.5 lb	CFXP4H
0.8 lb	CFXP8H
1.1 lb	CFXP12H

Monitor Arms

Surface Materials

Seating Upholstery

Buzz2

Price Group 1
 5F07 Blue
 5F08 Navy
 5F16 Grey
 5F17 Black
 5G51 Sable
 5G64 Alpine
 5G65 Tornado

Era

Price Group 1
 5ER0 Cobalt
 5ER6 Truffle
 5ER7 Saffron
 5ER9 Onyx
 5ES3 Persimmon
 5ES6 Royal Blue
 5ES7 Night Owl

New Black

Price Group 1
 5J10 Bruce
 5J11 Henry

New Black

Price Group 2
 5J08 Jack
 5J09 James
 5J12 Harley

Cogent: Connect

Price Group 2
 5S18 Scarlet
 5S21 Blue Jay
 5S23 Wasabi
 5S24 Nickel
 5S25 Graphite
 5S26 Licorice
 5S93 Indigo/Blueprint
 5S95 Sailor
 5S99 Lipstick/Merlot
 5SD0 Royal Blue
 5SD2 Peacock
 5SD3 Lagoon
 5SD4 Saffron

Foundation

Price Group 2
 5875 Black
 5876 Navy
 5877 Foggy Night
 5878 Sailor
 5880 Seal
 5885 Honey
 5886 Folkstone
 5887 Pebble

Stand In

Price Group 2
 5622 Lunar
 5623 Cyclone
 5624 Eclipse
 5634 Parsley
 5636 Atlantis
 5691 Orca
 5744 Blueberry

Billiard Multi-Use

Price Group 3
 5H11 Poppy
 5H16 Indigo
 5H17 Mallard
 5H18 Teak
 5H19 Cumulus
 5H20 Pewter
 5H21 Gunmetal
 5H22 Ink
 5H25 Storm Cloud
 5H26 Olivine

Bo Peep

Price Group 5
 5G67 Bone
 5G75 Pinot
 5G83 Nautical
 5G84 Gravel
 5G85 Sharkskin
 5G86 Kohl

Remix

Price Group 5
 RE03 Pebble
 RE06 Linen Beige
 RE08 Concrete Grey
 RE09 Sky Blue
 RE10 Blue Jean

Brisa

Price Group 6
 BR01 Black Onyx
 BR04 Truffle
 BR06 Ash
 BR07 Sage
 BR09 Sterling Blue
 BR10 Night Navy
 BR11 Cambridge Blue
 BR16 Cinnabar
 BR18 New Sand
 BR20 White
 BR21 Moccasin
 BR22 Buckskin
 BR24 Mineral
 BR26 Iron
 BR27 Stormy
 BR30 Bone
 BR31 Carmel
 BR32 Bridle

3D Knit

5064 Licorice
 5092 Graphite
 5093 Nickel

3D Microknit

5T20 Nickel
 5T21 Licorice
 5T22 Royal Blue
 5T29 Graphite
 5T31 Seagull
 5T37 Lagoon

Qivi Net

QN01 Wasabi
 QN04 Graphite
 QN07 Scarlet
 QN11 Peacock
 QN13 Merlot
 QN15 Lagoon
 QN16 Saffron

Connect 3D

5014 Royal Blue
 5018 Scarlet
 5021 Blue Jay
 5023 Wasabi
 5024 Nickel
 5025 Graphite
 5026 Licorice
 5030 Sailor
 5533 Peacock
 5535 Merlot
 5536 Lagoon
 5537 Saffron

Seating Plastic

6059 Sterling Dark Solid
 6160 Grey
 6205 Black
 6259 Midnight (Solar Black)
 6295 Near Black
 6332 Citron
 6335 Wasabi
 6336 Jazz
 6337 Element
 6338 Chili
 6527 Merle

Paint

Textured Paint

Price Group 1
 7041 Milk
 7042 Shale Grey
 7043 Moss
 7207 Black
 7239 Midnight **E**
 7241 Arctic White
 7360 Merle

Smooth Paint

Price Group 1
 4242 Milk

Smooth Metallic Paint

Price Group 2
 4799 Platinum Metallic

Smooth Paint

Price Group 2
 0835 Black

Accessory Paint

Price Group 2
 4144 Black Gloss

Seating Coating

7000 Black

Coalesse Paint

Price Group 1
 4138 Graphite Metallic Gloss
 4141 Platinum Matte
 4142 Platinum Gloss
 4145 Milk Gloss
 4180 Graphite Matte
 4710 Low Gloss Black

E = Excluded

Worktools Paint*Price Group 1*

4135 Black Matte
4142 Platinum Gloss
4231 Arctic White
4710 Low Gloss Black
7018 Pewter
ZW01 Pearl Snow

Vertical Surface Fabric**Sprite***Price Group A*

5540 Khaki
5541 Snow
5543 Linen
5547 Sky

Abacus ^E*Price Group 1*

P123 Portico
P124 Opus
P125 Cusp
P126 Artifact

Alloy*Price Group 1*

P525 Polar
P526 Skim
P527 Bubbly
P528 Tern
P529 Shore
P530 Asti
P531 Silver
P532 Oxide
P533 Element
P534 Construct
P535 Currency
P536 Iron

Buzz2*Price Group 1*

5F03 Tomato
5F04 Red ^E
5F06 Sky ^E
5F07 Blue
5F08 Navy
5F16 Grey
5F17 Black
5G51 Sable
5G55 Pumpkin
5G57 Rouge
5G59 Meadow
5G61 Cyan
5G63 Crocus
5G64 Alpine
5G65 Tornado

^E = Excluded**Charm***Price Group 1*

P507 Birch
P508 Sparkle
P510 Debut
P513 Twilight

Pianista*Price Group 1*

P421 Mist
P422 Rain
P424 Café
P425 Denim
P427 Stone
P428 Flax
P429 Oat
P430 Wheat

Rhythm*Price Group 1*

P555 Allegro
P556 Tempo
P560 Melody
P562 Opus

Tinsel*Price Group 1*

P515 Sugar
P520 Depth
P521 Bliss
P522 Grow
P523 Dolce

Boccie*Price Group 1*

P200 New Rice
P201 New Almond
P204 New Opal
P205 New Mist
P209 New Sky

Latch*Price Group 2*

P600 Seashell
P602 Eggshell
P603 Zen
P604 Cool Gray
P605 Armor
P609 Nimbus

Billiard Multi-Use*Price Group 3*

5H16 Indigo
5H18 Teak
5H19 Cumulus
5H20 Pewter
5H21 Gunmetal
5H22 Ink
5H25 Storm Cloud
5H26 Olivine

Laminate**HPL Solid Laminate***Price Group 1*

2730 Arctic White
2746 Black
2883 Seagull
2884 Milk

HPL Woodgrain Laminate*Price Group 1*

2406 Clear Cherry ^E
2409 Clear Maple
2410 Graphite Walnut
2412 Natural Cherry
2422 Medium Cherry ^E
2511 Winter on Maple ^E
2535 Virginia Walnut
2536 Blackwood
2538 Clear Walnut
2592 Blonde on Maple ^E
2714 Natural Walnut ^E
2HAK Clear Oak
2HAN Ash Noce
2HAT Acacia
2HAW Ash Wenge
2HBN Bisque Noce
2HBW Bisque Wenge
2HCN Clay Noce
2HCW Clay Wenge
2HSN Storm Noce
2HSW Storm Wenge

HPL Micro Laminate*Price Group 1*

2920 Marl Micro
2921 Gypsum Micro
2922 Clay Micro

HPL Patina Laminate*Price Group 1*

2870 Blonde Bronze Patina
2873 Instant Iron Patina

HPL Speckle Laminate*Price Group 1*

2823 Driftwood Speckle
2824 Smoke Speckle
2825 Vanadium Speckle

HPL Solid Laminate*Price Group 3*

24H1 Satin White
24H2 Satin Black

LPL Solid Laminate

247L Black V2 LPL
2L30 Arctic White LPL
2L83 Seagull LPL
2L84 Milk LPL
2L85 Dune LPL

LPL Woodgrain Laminate

24L0 Graphite Walnut LPL
25L1 Winter on Maple LPL ^E
25L5 Virginia Walnut LPL
25L6 Blackwood LPL
25L8 Clear Walnut LPL
26L1 Natural Cherry Version 2 LPL
2LAK Clear Oak LPL
2LAN Ash Noce LPL
2LAT Acacia LPL
2LAW Ash Wenge LPL
2LBN Bisque Noce LPL
2LBW Bisque Wenge LPL
2LCN Clay Noce LPL
2LCW Clay Wenge LPL
2LSN Storm Noce LPL
2LSW Storm Wenge LPL

Plastic

Systems Plastic

Price Group 1

- 6000 Black
- 6009 Arctic White
- 6034 Natural Cherry
- 6036 Medium Cherry
- 6037 Winter on Maple
- 6038 Blonde on Maple **E**
- 6041 Natural Walnut **E**
- 6052 Milk
- 6053 Seagull
- 6213 Acacia
- 6219 Clear Oak
- 6231 Graphite Walnut
- 6234 Clear Cherry
- 6237 Clear Maple
- 6242 Virginia Walnut
- 6243 Blackwood
- 6245 Clear Walnut
- 6249 Platinum Solid
- 6527 Merle
- 6619 Ice **E**
- 6631 Cream **E**
- 6636 Mist
- 6654 Sand
- 6695 Midnight
- 6697 Fog
- 6698 Fieldstone
- 6703 Ash Wenge
- 6704 Storm Wenge
- 6705 Bisque Wenge
- 6706 Clay Wenge
- 6707 Ash Noce
- 6708 Bisque Noce
- 6709 Clay Noce
- 6710 Storm Noce
- 6T02 Fawn Cypress
- 6T07 Walnut Heights

Worktools Plastic

- 6288 Charcoal

Veneer/Wood

Flat-Cut Open-Pore

Price Group 1

- 3062 Graphite Walnut
- 3402 Clear Cherry (Aged)
- 3412 Natural Cherry **E**
- 3422 Medium Cherry
- 3522 Clear Maple
- 3592 Blonde on Maple **E**
- 3702 Clear Walnut
- 3712 Natural Walnut
- 3752 Medium Walnut **E**
- 3762 Dark Walnut
- 3772 Medium Mahogany on Walnut

Quarter-Cut Natural Veneer

- 3042 Ash **E**
- 3222 Clear Maple
- 3292 Blonde on Maple **E**
- 3302 Clear Walnut
- 3312 Natural Walnut
- 3352 Medium Walnut **E**
- 3362 Dark Walnut
- 3372 Medium Mahogany on Walnut

Rift-Cut Open-Pore

Price Group 1

- 3602 Desert Oak

Coalesce Veneers

Price Group 1

- V3AK Natural Oak
- V3BK Desert Oak
- VP01 Light Oak
- VP05 White Oak

Metal

- 8040 Aluminum Matte Polished
- 8043 Clear Anodized Aluminum
- 8046 Polished Aluminum
- 8047 Silver Anodized Aluminum
- 9201 Polished Chrome
- 9250 Ember Chrome
- 9207 Polished Trivalent Chrome
- 9211 Nickel
- 9212 Silver

Ceramic

- 7655 White High Gloss
- 7661 Gray Chalk 6502C CS
- 7663 Black 6106U CS
- 7671 Arctic White 2 CS
- 7673 Merle CS
- 7674 Platinum Solid CS
- PV09 Hygienic White Gloss

Glass

- 6500 Clear
- 6511 Acid Etched
- ACM Moonlight

E = Excluded

Resources

Style Number Index

484

Style Number Index

Style Number	Page	Description
120	110	Collaboration Guest Chair
216	111	Bob Lounge Swivel Chair
221	111	Bob Lounge Chair w/Headrest
221-H	111-112	Bob Ottoman
231	112	Bob Guest Chair
418A000	97	SILQ 418 Series Chair
418B000	98	SILQ 418 Series Stool
428310	101	Qivi 428 Sled-Base Multi-Use Chair
428510	99	Qivi 428 Collab Chair
428710	100	Qivi 428 Collab Stool
428910	101	Qivi 428 Sled-Base Multi-Use Chair
434110	102	cobi 434 Work Chair
434111	102	cobi 434 Work Chair/Arm
434710	103	cobi 434 Work Stool
434711	103	cobi 434 Work Stool/Arm
435A00	94	Steelcase Series 1 Work Chair
435B00	95	Steelcase Series 1 Stool
435COATHANGER	96	Steelcase Series 1 Hanger
435HEADREST	96	Steelcase Series 1 Headrest
436AIR	87	Steelcase Series 2 Work Chair
436AIR3D	85	Steelcase Series 2 Work Chair
436AIR3DSTOOL	91	Steelcase Series 2 Stool
436AIRSTOOL	92	Steelcase Series 2 Stool
436COATHANGER	93	Steelcase Series 2 Coat Hanger
436HEADREST	93	Steelcase Series 2 Headrest
436UPH	83	Steelcase Series 2 Work Chair
436UPHSTOOL	89	Steelcase Series 2 Stool
442A30	57	Gesture 442 Shell Bck Chair
442A40	57	Gesture 442 Wrapped Bck Chair
442A50	58	Gesture 442 Series Wrk Chr w/Headrest
442B30	59	Gesture 442 Shell Bck Stool
442B40	59	Gesture 442 Wrapped Bck Stool
46-T2	385	Await Freestanding Table
46216179	60	Leap 462 Work Chair
46216189	61	Leap 462 Work Chair
46267179	62	Leap 462 Stool
46267189	63	Leap 462 Stool
46296179	64	Leap Plus 462 Work Chair
46296189	65	Leap Plus 462 Work Chair
465A000	69	Think 465 Series Work Chair
465A300	66	Think 465 Series Work Chair
465B000	73	Think 465 Series Stool
465B300	70	Think 465 Series Stool
477100	152	Max-Stacker III 477 Series Stackable Chair
480110	104	Node 480 Series Work Chair
480120	104	Node 480 Series Work Chair
480130	105	Node 480 Series Collaborative Chair
480140	108	Node 480 Series Collaborative Stool
480150	105	Node 480 Series Collaborative Chair
480210	106	Node 480 Series MidBk Collab Chair
480220	106	Node 480 Series MidBk Collab Chair
480230	107	Node 480 Series MidBk Collab Chair
480240	109	Node 480 Series MidBk Collab Stool
480250	107	Node 480 Series MidBk Collab Chair
4821410	74	Amia 482 Series Work Chair

Style Number	Page	Description
4821412	77	Amia 482 Series Air Back Work Chair
4821414	76	Amia 482 Series Air Back Work Chair
4821418	75	Amia 482 Series Chair
4827410	78	Amia 482 Series Stool
4827412	81	Amia 482 Series Air Back Stool
4827414	80	Amia 482 Series Air Back Stool
4827418	79	Amia 482 Series Stool
490410	148	Move 490
490410C	148	Move 490
490410CP	149	Move 490
490410P	149	Move 490
490410U	148	Move 490
490410UC	148	Move 490
490412	149	Move 490
490412C	149	Move 490
490412CP	149	Move 490
490412P	149	Move 490
490412U	149	Move 490
490412UC	149	Move 490
490710	150	Move 490
490710C	150	Move 490
490710CP	151	Move 490
490710P	151	Move 490
490710U	150	Move 490
490710UC	150	Move 490
490712	151	Move 490
490712C	151	Move 490
490712CP	151	Move 490
490712P	151	Move 490
490712U	151	Move 490
490712UC	151	Move 490
800DV12	439	Dividers
800DV6	439	Dividers
800RW	438	Rail
877102002SR	441	Master Lock Tool
877102003SR	441	Standard Lock Tool
AHCC	469	Vertical Cable Carrier
AWAG2	222	2½" Round Grommet
AWM06	470	6" Wire Manager
AWM12	470	12" Wire Manager
AWM18	470	18" Wire Manager
AWM23	470	23" Wire Manager
AWM30	470	30" Wire Manager
AWM35	470	35" Wire Manager
AWM42	470	42" Wire Manager
AWM48	470	48" Wire Manager
AWVW	222	Wire Mgr
BFR30	360	U Tbl Round
BFR36	360	U Tbl Round
BFR42	360	U Tbl Round
BFR48	360	U Tbl Round
BFR54	360	U Tbl Round
BFRQ24	361	U Tbl Square
BFRQ30	361	Univ Tbl Square
BFRQ36	361	U Tbl Square

Style Number	Page	Description	Style Number	Page	Description
BFRQ42	361	U Tbl Square	COFOFLRD	374	Potrero415 Light Round Table
BFRQ48	361	U Tbl Square	COFOFLREC	377	Potrero415 Light Rectangular Table
BFRQ54	361	U Tbl Square	COFOFLRECST	377	Potrero415 Light Rectangular Table
BFRR3660	362	U Tbl Rectangle	COFOFLRECW	379	Potrero415 Light Rectangular Tbl, Wd Legs
BFRR3666	362	U Tbl Rectangle	COFOFRD	372	Potrero415 Round Table, Metal Legs
BFRR3672	362	U Tbl Rectangle	COFOFREC	373	Potrero415 Rect. Table, Metal Legs
BFRR4284	362	U Tbl Rectangle	COJHL100	134	Visalia Lounge
BFRR4896	362	U Tbl Rectangle	COJHL200	134	Visalia Lounge
BFS2430	359	U Tbl Str	COJHL300	134	Visalia Lounge
BFS2436	359	U Tbl Str	COLAGTP	387	Lagunitas Personal Table
BFS2442	359	Univ Tbl Str	COMARCCH5	117	Marien152 Conference Seating
BFS2448	359	U Tbl Str	COMARCHMB	119	Marien152 Guest Seating, Metal Base
BFS2454	359	U Tbl Str	COMARCHWB	118	Marien152 Guest Seating, Wood Base
BFS2460	359	U Tbl Str	COMCCHLBSTNT	121	Massaud Low-Back Duvet Conference Chair
BFS2466	359	U Tbl Str	COMCCHMBST	120	Massaud Mid-Back Duvet Conference Chair
BFS2472	359	U Tbl Str	COPP01	474	PowerPod
BFS2478	359	U Tbl Str	COSFZCH	123	Montara650 Chair
BFS3036	359	U Tbl Str	COSFZCTR	381	Montara650 Café-Height Table
BFS3042	359	U Tbl Str	COSFZST	124	Montara650 Stools
BFS3048	359	U Tbl Str	COSFZWTRD	380	Montara650 Work-Height Table
BFS3054	359	U Tbl Str	CPRCCL	452	Vertical Locking CPU Cradle
BFS3060	359	U Tbl Str	CPRCN	452	Vertical Non-Locking CPU Cradle
BFS3066	359	U Tbl Str	CPRSLFO	453	Vert Processor Sling, Fixed
BFS3072	359	U Tbl Str	CRBK	283-284	Bookcase
BFS3078	359	U Tbl Str	CRBKS15H	289-290	Currency Bookcase, Stacking, 1.5-High
BPL	364	U Tbl Post Leg	CRBKS1H	287-288	Currency Bookcase, Stacking, One-High
BPL4	364	U Tbl Post Leg	CRBKS2H	291-292	Curr Bookcase, Stacking, Two-High, or Desk
BPL4C	364	U Tbl Post Leg	CRBRG	249	Bridge
BPLC	364	U Tbl Post Leg	CRC	263	Cushion Top
BT26	363	Univ Tbl Base	CRCD15HFSLFL	274	Curr Credenza, 1.5-High, Lateral/Open
BT36	363	Univ Tbl Base	CRCD15HFSLFR	273	Curr Credenza, 1.5-High, Open/Lateral
BX26	363	U Tbl Base	CRCD15HFSLL	274	Curr Credenza, 1.5-High, Lateral/Lateral
BX36	363	U Tbl Base	CRCD15HFSSO	273	Curr Credenza, 1.5-High, Open/Open
CFINTRO	475	CF Intro Single	CRCD2HFSCLL	279	Curr Credenza, Two-High, Cabinet/Cabinet
CFINTRODSLIDE	475	CF Intro Dual with sliders	CRCD2HFSCLFLFR	279	Curr Credenza, Two-High, Lateral/Cabinet
CFLHS	476	CF Laptop Holder Tray Platform	CRCD2HFSCLFR	279	Curr Credenza, Two-High, Cabinet/Lateral
CFMSC	476	CF Single Connector Monitor Bracket	CRCD2HFSFL	278	Curr Credenza, Two-High, Lateral/Open
CFSERIESCC	477	CF C-Clamp	CRCD2HFSLFR	277	Curr Credenza, Two-High, Open/Lateral
CFSPSW	477	CF Flat Pnl Monitor Brkt	CRCD2HFSLL	278	Curr Credenza, Two-High, Lateral/Lateral
CFSPWM	477	CF Flat Pnl Monitor Brkt	CRCD2HFSSO	277	Curr Credenza, Two-High, Open/Open
CFTHSLIDE	478	CF Adjustable Monitor Adapter	CRCD2HKSDP	281	Curr Credenza, 2H, Kneespace, Dbl Ped
CFTHSLIDEHD	478	CF Adjustable Monitor Adapter	CRCD2HKSSPL	281	Curr Credenza, 2H, Kneespace, Sgl Ped LH
CFTHSLIDEWO	478	CF Adjustable Monitor Adapter	CRCD2HKSSPR	281	Curr Credenza, 2H, Kneespace, Sgl Ped RH
CFTR	452	Adjustable Foot Rest	CRCT	255	Common Top, rectangular
CFXP12H	479	CF Arm Extensions for Pole Mount	CRDSHL	232	Currency Desk Shell
CFXP4H	479	CF Arm Extensions for Pole Mount	CRDSHLB	239	Bow Front Desk and Desk Shell
CFXP8H	479	CF Arm Extensions for Pole Mount	CRDSHLO	235	Currency Desk Shell, 6" Overhang
CO200G	114	Bindu-Low Back Guest/Side Chair	CRDSKBDP	240	Bow Front Desk and Desk Shell
CO300	113	Bindu-Mid Back Executive Chair	CRDSKBSPL	240	Bow Front Desk and Desk Shell
COCF5	386	Free Stand Occasional Table	CRDSKBSPR	240	Bow Front Desk and Desk Shell
COEL100	115	Enea Lottus Armless Chair	CRDSKCC	244	Curved Corner Desk Shell
COEL100UPH	115	Enea Lottus Armless Chair	CRDSKDP	233	Currency Desk Pedestal, Double
COEL400	116	Enea Lottus Sled-Base Stool	CRDSKEL	243	Extended Curved Corner Desk Shell
COEL400UPH	116	Enea Lottus Sled-Base Stool	CRDSKER	243	Extended Curved Corner Desk Shell
COFOFCABL	382	Potrero415 Mesh Cable Manager	CRDSKODP	236	Currency Desk Pedestal, Double, 6" Ovrhng

Style Number Index, continued

Style Number	Page	Description
CRDSKOSPL	236	Curr Desk Ped, Single, Left Hand, 6" Over
CRDSKOSPR	236	Curr Desk Ped, Single, Right Hand, 6" Over
CRDSKSPL	233	Currency Desk Pedestal, Single, Left Hand
CRDSKSPR	233	Currency Desk Pedestal, Single, Right Hand
CRDWKSF	250	D-Shape Worksurface
CRFP	269	Filler Panel
CRHAD15H	271	Lower Storage, 1.5-High HAD
CRHAD1H	271	Lower Storage, One-High HAD
CRHADCT	253	Common Top, HAD application
CRL15HBF	265	Curr 1.5H, Box/File Lateral
CRL15HOF	265	Curr 1.5H, Open/File Lateral
CRL1H	265	Lateral, One-High
CRL2H	265	Currency, One-High, One-High,
CRLS15HD	267	Curr 1.5H Lower Storage, Cabinet
CRLS15HO	267	Curr 1.5H Lower Storage, Open
CRLS1H	267	Low Storage, One-High
CRLS2HD	268	Curr 2H Lower Storage, Cabinet
CRLS2HO	268	Curr 2H Lower Storage, Open
CRMP	256	Modesty Panel
CRMP15H	263	Mobile Pedestal, 1.5-High
CRMP2HBBF	263	Currency, Two-High Mobile Pedestals
CRMP2HFF	263	Currency, Two-High Mobile Pedestals
CRMP2HOBF	263	Currency, Two-High Mobile Pedestals
CROHHD	295	Currency, Overhead
CROHOP	296	Currency, Overhead
CROHOS	296	Currency, Overhead
CROHSDP	295	Currency, Overhead
CROHSHD	299	Currency, Stacking Overhead
CROHSO	300	Stacking Overhead, No Doors, Opn
CROHSSD	299	Currency, Stacking Overhead
CRORP	303	Organizer—Personal
CRORS	303	Organizer—Personal
CRPD15H	259	Pedestal, 1.5-High
CRPD2HBBF	259	Two-High Fixed Pedestals
CRPD2HFF	259	Two-High Fixed Pedestals
CRPD2HOBF	259	Two-High Fixed Pedestals
CRPDSL2HBBF	261	Two-High Fxd Pedestals For Use with Shells
CRPDSL2HFF	261	Two-High Fxd Pedestals For Use with Shells
CRPDSL2HOBF	261	Two-High Fxd Pedestals For Use with Shells
CRPWKSF	251	P-Shape Worksurface
CRRTNL	247	Currency Return Shell, Left Hand
CRRTNR	248	Currency Return Shell, Right Hand
CRRTNSPL	248	Currency Return Pedestal, Single, Left Hand
CRRTNSPR	248	Currency Return Pedestal, Sngl, Right Hand
CRTBWM	304	Currency Tackboard, Wallmount
CRTWBFL	307	Curr Tower, Sngl Dr w/ Drawers
CRTWBFR	307	Curr Tower, Sngl Dr, BF, Hinged Left
CRTWDBFL	311	Curr Tower, Dual Dr, BF, Cabinet Left
CRTWDBFR	311	Curr Tower, Dual Dr, BF, Cabinet Right
CRTWDFFL	312	Curr Tower, Dual Dr, FF, Cabinet Left
CRTWDFFR	312	Curr Tower, Dual Dr, FF, Cabinet Right
CRTWFFL	308	Curr Tower, Single Dr, FF, Hinged Left
CRTWFFR	308	Curr Tower, Single Door, FF, Hinged Right
CRTWSABBFL	315	Curr Tower, Side Access, BBF, Cabinet Left
CRTWSABBFR	315	Curr Tower, Side Access, BBF, Cabinet R

Style Number	Page	Description
CRTWSAFFL	316	Curr Tower, Side Access, FF, Cabinet Left
CRTWSAFFR	316	Curr Tower, Side Access, FF, Cabinet Right
CRWDL	319	Curr Cabinet, Hinged Left
CRWDR	319	Curr Cabinet, Hinged Right
DSPIINTRO	471	Powerstrip Intro
DSPPOWER	473	Desktop Powerstrip Plus USB/Data
DSVCMHC	469	High-Capacity Cable Riser
FLXCTBD	389	Flex, Board Cart
FLXFSAG	388	Flex, Freestanding Screen, Angled
FLXFSRQ	388	Flex, Freestanding Screen, Rectangle
FLXMB	390	Flex, Markerboard
FLXMB4	390	Flex, Markerboard Package
FLXSTAND	390	Flex, Stand
HR223DU	153	Empath Recliner w/Fully Upholstered Arm
KDIV02	414	Bookends
L52FT	468	Bottomline
L52FTCHI	468	Bottomline
L52FTS	468	Bottomline
L52FTY	468	Bottomline
L53FT	468	Bottomline
L53FTCHI	468	Bottomline
L53FTS	468	Bottomline
L53FTY	468	Bottomline
L54FT	468	Bottomline
L54FTCHI	468	Bottomline
L54FTS	468	Bottomline
L54FTY	468	Bottomline
LDASHC	455	dash LED Light, C-clamp Mount
LDASHF	455	dash LED Light, Freestanding
LDASHMINIC	457	dash mini LED Light, C-clamp Mount
LDASHMINIF	457	dash mini LED Light, Freestanding
LDASHMINIOC	458	dash mini LED Light, C-clamp Mount
LDASHMINIOF	458	dash mini LED Light, Freestanding
LDASHMINIOP	458	dash mini LED Light, Pnl-Mount
LDASHMINIOR	458	dash mini LED Light, Rail-Mount
LDASHMINIOS	458	dash mini LED Light, Slatwall/SlatRail Mount
LDASHMINIOU	458	dash mini LED Light, Free USB, Occ Snsr
LDASHMINIP	457	dash mini LED Light, Pnl-Mount
LDASHMINIR	457	dash mini LED Light, Rail-Mount
LDASHMINIS	457	dash mini LED Light, Slatwall/SlatRail Mount
LDASHMINIU	457	dash mini LED Light, Freestanding USB
LDASHOC	456	dash LED Light, C-clamp Mount
LDASHOF	456	dash LED Light, Freestanding
LDASHOP	456	dash LED Light, Pnl-Mount
LDASHOR	456	dash LED Light, Rail-Mount
LDASHOS	456	dash LED Light, Slatwall/SlatRail Mount
LDASHOU	456	dash LED Light, Freestand USB, Occ Snsr
LDASHP	455	dash LED Light, Pnl-Mount
LDASHR	455	dash LED Light, Rail-Mount
LDASHS	455	dash LED Light, Slatwall/SlatRail Mount
LDASHU	455	dash LED Light, Freestanding USB
LLL17	466	LED Linear Shelf Light
LLL17YA	466	LED Linear Shelf Light
LLL17YB	466	LED Linear Shelf Light
LLL31	466	LED Linear Shelf Light

Style Number	Page	Description	Style Number	Page	Description
LLL31YB	466	LED Linear Shelf Light	RAACW5	439	Counterweight Pkg
LLL44	467	LED Linear Shelf Light	RAANBRK	440	Anchor Bracket Pkg
LLL44YB	467	LED Linear Shelf Light	RAHF30	438	Hanging Folder Bars
LLL58	467	LED Linear Shelf Light	RAHF36	438	Hanging Folder Bars
LLL58YB	467	LED Linear Shelf Light	RAHF42	438	Hanging Folder Bars
LLLDD	460	LED Linear Desktop Light	RATCL15108_	433	Square Edge Top
LLLDS	460	LED Linear Desktop Light	RATCL1548_	433	Square Edge Top
LLRDD	459	LED Radial Desktop Light	RATCL1560_	433	Square Edge Top
LLRDS	459	LED Radial Desktop Light	RATCL1566_	433	Square Edge Top
LOCKFR	441	Lock Cylinder	RATCL1572_	433	Square Edge Top
LOCKXF	441	Lock Cylinder	RATCL1578_	433	Square Edge Top
LS1FSC	465	Daisy Chain Cord	RATCL1584_	433	Square Edge Top
LS6FSC	465	Daisy Chain Cord	RATCL1590_	433	Square Edge Top
LSCTSKLIGHT1	461	LED Intro Task Light	RATCL1596_	433	Square Edge Top
LSCTSKLIGHT2	461	LED Intro Task Light	RATCL18108_	433	Square Edge Top
LSL18	462	LED Light	RATCL1860_	433	Square Edge Top
LSL18YA	462	LED Light	RATCL1866_	433	Square Edge Top
LSL18YB	462	LED Light	RATCL1872_	433	Square Edge Top
LSM24K	464	Standard Light	RATCL1878_	433	Square Edge Top
LSM24KC	464	Standard Light	RATCL1884_	433	Square Edge Top
LSM24KD	464	Standard Light	RATCL1890_	433	Square Edge Top
LSM36K	464	Standard Light	RATCL1896_	433	Square Edge Top
LSM36KC	464	Standard Light	RATCL24108_	433	Square Edge Top
LSM36KD	464	Standard Light	RATCL2460_	433	Square Edge Top
LSM48K	464	Standard Light	RATCL2466_	433	Square Edge Top
LSM48KC	464	Standard Light	RATCL2472_	433	Square Edge Top
LSM48KD	464	Standard Light	RATCL2490_	433	Square Edge Top
MGELCRQ	321	Migration SE Desk-Rect,C-Leg Ext Hgt	RATCL2496_	433	Square Edge Top
MGELTRQ	320	Migration SE,Desk-Rect, Ext hght	RATCL30108_	434	Square Edge Top
MIGCBK4	322	Migration, Cable Bracket	RATCL3048_	433	Square Edge Top
MIGCR	322	Migration, Cable Riser	RATCL3060_	433	Square Edge Top
OLCB	326	Ology, Cable Basket	RATCL3066_	433	Square Edge Top
OLCBK4	326	Ology, Cable Bracket	RATCL3072_	434	Square Edge Top
OLCR	326	Cable Riser	RATCL3078_	434	Square Edge Top
OLELRQ	325	Ology, Hgt-Adj Desk, Rectangular	RATCL3084_	434	Square Edge Top
OLSLRQ	325	Ology, Hgt-Adj Desk, Rectangular	RATCL3090_	434	Square Edge Top
PAB12M	440	Attachment Cable	RATCL3096_	434	Square Edge Top
PHSCRN	397	Sarto Curved Screen	RATCL3636_	434	Square Edge Top
PLSCRN	396	Sarto Curved Screen	RATCL3672_	434	Square Edge Top
PSPM	393	Sarto Privacy Screens	RATCL4836_	434	Square Edge Top
PSPS	395	Sarto Privacy Screens	RATCL4872_	434	Square Edge Top
PVLTSANS	448	CeramicSteel Sans Light	RATCTHAD	435	Common Top
PWBTKBRD	444, 446	Tackboard	RATF1524	430	Steel Security Top
PWBWTBRD	443, 445	Whiteboard	RATF1530	430	Steel Security Top
Q20T	454	20" Track	RATF1536	430	Steel Security Top
Q23T	454	23" Track	RATF1542	430	Steel Security Top
RAACB2401	440	Counterweight Package	RATF1830F	430	Steel Security Top
RAACB3001	440	Counterweight Package	RATF1830P	430	Steel Security Top
RAACB3601	440	Counterweight Package	RATF1836F	430	Steel Security Top
RAACB4201	440	Counterweight Package	RATF1836P	430	Steel Security Top
RAACW1	439	Counterweight Pkg	RATF1842F	430	Steel Security Top
RAACW15	402	Counterweight Pkg	RATF1842P	430	Steel Security Top
RAACW2	439	Counterweight Pkg	RATF2430F	430	Steel Security Top
RAACW3	439	Counterweight Pkg	RATF2430P	430	Steel Security Top
RAACW4	439	Counterweight Pkg	RATF2436F	430	Steel Security Top

Style Number Index, continued

Style Number	Page	Description
RATF2436P	430	Steel Security Top
RATL1524_	432	Square Edge Top
RATL1530_	432	Square Edge Top
RATL1536_	432	Square Edge Top
RATL1542_	432	Square Edge Top
RATL1830_	432	Square Edge Top
RATL1836_	432	Square Edge Top
RATL1842_	432	Square Edge Top
RATL2430_	432	Square Edge Top
RATL2436_	432	Square Edge Top
RBB24QTAK	408	U Ovr the Case Bin
RBB24TAK	409	U In the Case Bin
RBB30QTAK	408	U Ovr the Case Bin
RBB30TAK	409	U In the Case Bin
RBB36QTAK	408	U Ovr the Case Bin
RBB36TAK	409	U In the Case Bin
RBB42QTAK	408	U Ovr the Case Bin
RBB42TAK	409	U In the Case Bin
RBB48QTAK	408	U Ovr the Case Bin
RBB48TAK	409	U In the Case Bin
RBB60QTAK	408	U Ovr the Case Bin
RBB60TAK	409	U In the Case Bin
RBB66QTAK	408	U Ovr the Case Bin
RBB66TAK	409	U In the Case Bin
RBB72QTAK	408	U Ovr the Case Bin
RBB72TAK	409	U In the Case Bin
RBC15242A	429	Univ Bookcase
RBC15243A	429	Univ Bookcase
RBC15244A	429	Univ Bookcase
RBC15245A	429	Univ Bookcase
RBC15246A	429	Univ Bookcase
RBC15302A	429	Univ Bookcase
RBC15303A	429	Univ Bookcase
RBC15304A	429	Univ Bookcase
RBC15305A	429	Univ Bookcase
RBC15306A	429	Univ Bookcase
RBC15362A	429	Univ Bookcase
RBC15363A	429	Univ Bookcase
RBC15364A	429	Univ Bookcase
RBC15365A	429	Univ Bookcase
RBC15366A	429	Univ Bookcase
RBC15422A	429	Univ Bookcase
RBC15423A	429	Univ Bookcase
RBC15424A	429	Univ Bookcase
RBC15425A	429	Univ Bookcase
RBC15426A	429	Univ Bookcase
RBKHWM24	412	Wall Bracket
RBKHWM30	412	Wall Bracket
RBKHWM36	412	Wall Bracket
RBKHWM42	412	Wall Bracket
RBKHWM48	412	Wall Bracket
RBKHWM60	412	Wall Bracket
RBKHWM72	412	Wall Bracket
RBKVOFM	413	Vert OM Brkt
RDIV	412	Dividers

Style Number	Page	Description
RDS24TAK	411	U Personal Shelf
RDS30TAK	411	U Personal Shelf
RDS36TAK	411	U Personal Shelf
RDS42TAK	411	U Personal Shelf
RDS48TAK	411	U Personal Shelf
RDV1506	437	Dividers
RDV1512	437	Dividers
RDV151210	437	Dividers
RLF18301_	418	U One-High Lat File
RLF18301A_	418	U 1.5-High Lat File
RLF18301B_	419	U 1.5-High Lat File
RLF18301C_	419	U 1.5-High Lat File
RLF18301D_	419	U 1.5-High Lat File
RLF18302_	419	U Lat File
RLF18303_	423	Univ Lat File
RLF18304_	423	Univ Lat File
RLF18305_	423	Univ Lat File
RLF18361_	418	U One-High Lat File
RLF18361A_	418	U 1.5-High Lat File
RLF18361B_	419	U 1.5-High Lat File
RLF18361C_	419	U 1.5-High Lat File
RLF18361D_	419	U 1.5-High Lat File
RLF18362_	419	U Lat File
RLF18363_	423	Univ Lat File
RLF18364_	423	Univ Lat File
RLF18365_	423	Univ Lat File
RLF18421_	418	U One-High Lat File
RLF18421A_	418	U 1.5-High Lat File
RLF18421B_	419	U 1.5-High Lat File
RLF18421C_	419	U 1.5-High Lat File
RLF18421D_	419	U 1.5-High Lat File
RLF18422_	419	U Lat File
RLF18423_	423	Univ Lat File
RLF18424_	423	Univ Lat File
RLF18425_	423	Univ Lat File
RLF24301A_	418	U 1.5-High Lat File
RLF24301B_	419	U 1.5-High Lat File
RLF24301C_	419	U 1.5-High Lat File
RLF24301D_	419	U 1.5-High Lat File
RLF24302_	419	U Lat File
RLF24303_	423	Univ Lat File
RLF24304_	423	Univ Lat File
RLF24305_	423	Univ Lat File
RLF24361A_	418	U 1.5-High Lat File
RLF24361B_	419	U 1.5-High Lat File
RLF24361C_	419	U 1.5-High Lat File
RLF24361D_	419	U 1.5-High Lat File
RLF24362_	419	U Lat File
RLF24363_	423	Univ Lat File
RLF24364_	423	Univ Lat File
RLF24365_	423	Univ Lat File
RPF1827A_	401	U Fixed Pedestal
RPF1827B_	401	U Fixed Pedestal
RPF2427A_	401	U Fixed Pedestal
RPF2427B_	401	U Fixed Pedestal

Style Number	Page	Description	Style Number	Page	Description
RPF3027A	401	U Fixed Pedestal	RSH42TAK	410	U Shelf
RPF3027B	401	U Fixed Pedestal	RSH48TAK	410	U Shelf
RPM1821C	407	U Mobile Pedestal	RSH60TAK	410	U Shelf
RPM21827A	407	U Mobile Pedestal	RSH72TAK	410	U Shelf
RPM21827B	407	U Mobile Pedestal	RUK24TAK	413	Std OH Upmnt Pkg
RPM22427A	407	U Mobile Pedestal	RUK30TAK	413	Std OH Upmnt Pkg
RPM22427B	407	U Mobile Pedestal	RUK36TAK	413	Std OH Upmnt Pkg
RPM2421C	407	U Mobile Pedestal	RUK42TAK	413	Std OH Upmnt Pkg
RPXCK22718F	404	U Conv Kit	RUK48TAK	413	Std OH Upmnt Pkg
RPXCK22718P	404	U Conv Kit	RUK60TAK	413	Std OH Upmnt Pkg
RPXCK22724F	404	U Conv Kit	RUK72TAK	413	Std OH Upmnt Pkg
RPXCK22724P	404	U Conv Kit	RXADRL15	437	Rails
RPXCK22730F	404	U Conv Kit	RXADRL24	438	Rails
RPXCK22730P	404	U Conv Kit	RXADRL2442	438	Rails
RPXDPT	405	Pencil Tray	RXSA1524	436	Univ Storage Cabinet
RPXFMONFP	402	Univ Ped Filler	RXSA1530	436	Adjustable Steel Standard Shelf
RPXFMONPP	402	Univ Ped Filler	RXSA1536	436	Adjustable Steel Standard Shelf
RPXFTAKFP	402	U Fil Prd Frnt Ped	RXSA1542	436	Adjustable Steel Standard Shelf
RPXFTAKPP	402	U Fil Prd Frnt Ped	RXSA1830	436	Adjustable Steel Standard Shelf
RPXFTINT	403	Univ Pedestal Interlock	RXSA1836	436	Adjustable Steel Standard Shelf
RQS24244LA	421	U Open Side Tower	RXSA1842	436	Adjustable Steel Standard Shelf
RQS24244RA	421	U Open Side Tower	RXSA2415	436	Adj Steel Std Shelf
RQS24245LC	421	U Open Side Tower	RXSA2424	436	Adjustable Steel Standard Shelf
RQS24245RC	421	U Open Side Tower	RXSA2430	436	Adjustable Steel Standard Shelf
RSC18301A	418	U One-High Lat File	RXSA2436	436	Adjustable Steel Standard Shelf
RSC18302A	425	Univ Storage Cabinet	RXSA3015	436	Adj Steel Std Shelf
RSC18303C	425	Univ Storage Cabinet	SANS	447	CeramicSteel Sans
RSC18304F	425	Univ Storage Cabinet	SC1060SA	154	Sorrel 18"W Stacking Chair
RSC18305K	425	Univ Storage Cabinet	SC1060SN	154	Sorrel 18"W Stacking Chair
RSC18306Q	426	Univ Storage Cabinet	SC1065SA	154	Sorrel Bariatric Stacking Chair
RSC18361A	418	U One-High Lat File	TS2PBBF22M	398	Mobile Ped
RSC18362A	425	Univ Storage Cabinet	TS2PBDD	400	Box Dwr Divider
RSC18363C	425	Univ Storage Cabinet	TS2PBF19M	398	Mobile Ped
RSC18364F	425	Univ Storage Cabinet	TS2PBF22M	398	Mobile Ped
RSC18365K	425	Univ Storage Cabinet	TS2PBF22MC	399	Mobile Ped
RSC18366Q	426	Univ Storage Cabinet	TS2PBF22MCH	399	Mobile Ped
RSC18421A	418	U One-High Lat File	TS2PFDD	400	File Dwr Divider
RSC18422A	425	Univ Storage Cabinet	TS2PFF22M	398	Mobile Ped
RSC18423C	425	Univ Storage Cabinet	TS2PPT	400	Pencil Tray
RSC18424F	425	Univ Storage Cabinet	TS31201A	135	Shortcut Chair
RSC18425K	425	Univ Storage Cabinet	TS31202B	136	Shortcut Stool
RSC18426Q	426	Univ Storage Cabinet	TS31203	141	Shortcut Cushion
RSC24302A	425	Univ Storage Cabinet	TS31204A	138	Shortcut X Base Chair
RSC24303C	425	Univ Storage Cabinet	TS31205B	139	Shortcut X Base Stool
RSC24304F	425	Univ Storage Cabinet	TS31207A	140	Shortcut Tripod Base Chair
RSC24305K	425	Univ Storage Cabinet	TS31208A	140	Shortcut Tripod Base Chair
RSC24306Q	426	Univ Storage Cabinet	TS31209A	137	Shortcut Chair with Personal Worksurface
RSC24362A	425	Univ Storage Cabinet	TS3BC	125	Campfire Big Lounge
RSC24363C	425	Univ Storage Cabinet	TS3BCWM	126	Campfire Big Lounge—Waterfall
RSC24364F	425	Univ Storage Cabinet	TS3CRIN60S	131	Campfire Corner Lounge
RSC24365K	425	Univ Storage Cabinet	TS3CRIN60WM	132	Campfire 60° Corner Lounges —Waterfall
RSC24366Q	426	Univ Storage Cabinet	TS3CRIN90S	129	Campfire Corner Lounge
RSH24TAK	410	U Shelf	TS3CRIN90WM	130	Campfire 90° Corner Lounges —Waterfall
RSH30TAK	410	U Shelf	TS3CROUT60S	131	Campfire Corner Lounge
RSH36TAK	410	U Shelf	TS3CROUT60WM	132	Campfire 60° Corner Lounges —Waterfall

Style Number Index, continued

Style Number	Page	Description
TS3CROUT90S	129	Campfire Corner Lounge
TS3CROUT90WM	130	Campfire 90° Corner Lounges —Waterfall
TS3GANGING	133	Campfire Ganging Bracket
TS3HL	127	Campfire Half Lounge
TS3HLWM	128	Campfire Half Lounge—Waterfall
TS3WG	133	Campfire Wedge
TS4L27PG	330	Groupwork Post Leg
TS4L27PG4	330	Groupwork Post Leg
TS4LSHPG	330	Groupwork Post Leg
TS4LSHPG4	331	Groupwork Post Leg
TS4S2454	335	Groupwork Screen
TS4S2466	335	Groupwork Screen
TS4S3054	335	Groupwork Screen
TS4S3066	335	Groupwork Screen
TS4S3654	335	Groupwork Screen
TS4S3666	335	Groupwork Screen
TS4S4254	335	Groupwork Screen
TS4S4266	335	Groupwork Screen
TS4S4854	335	Groupwork Screen
TS4S4866	335	Groupwork Screen
TS4SR24	336	Groupwork Marker Tray
TS4SR30	336	Groupwork Marker Tray
TS4SR36	336	Groupwork Marker Tray
TS4SR42	336	Groupwork Marker Tray
TS4SR48	336	Groupwork Marker Tray
TS4TBASE22	329	Groupwork Table Base
TS4TBASE28	329	Groupwork Table Base
TS4TBASE285	329	Groupwork Table Base
TS4TCAFE22	329	Groupwork Table Base
TS4TCAFE28	329	Groupwork Table Base
TS4TCAFE285	329	Groupwork Table Base
TS4TCOF22	329	Groupwork Table Base
TS4THDR24	328	Groupwork Table Top
TS4THDR30	328	Groupwork Table Top
TS4THDR36	328	Groupwork Table Top
TS4THDR42	328	Groupwork Table Top
TS4THDR48	328	Groupwork Table Top
TS4THR1848	327	Groupwork Table Top
TS4THR1860	327	Groupwork Table Top
TS4THR1866	327	Groupwork Table Top
TS4THR1872	327	Groupwork Table Top
TS4THR1884	327	Groupwork Table Top
TS4THR2424	328	Groupwork Table Top
TS4THR2436	327	Groupwork Table Top
TS4THR2442	327	Groupwork Table Top
TS4THR2448	327	Groupwork Table Top
TS4THR2460	327	Groupwork Table Top
TS4THR2466	327	Groupwork Table Top
TS4THR2472	327	Groupwork Table Top
TS4THR2484	327	Groupwork Table Top
TS4THR3030	328	Groupwork Table Top
TS4THR3036	327	Groupwork Table Top
TS4THR3042	327	Groupwork Table Top
TS4THR3048	327	Groupwork Table Top
TS4THR3060	327	Groupwork Table Top

Style Number	Page	Description
TS4THR3066	327	Groupwork Table Top
TS4THR3072	327	Groupwork Table Top
TS4THR3636	328	Groupwork Table Top
TS4THR4242	328	Groupwork Table Top
TS4THR4848	328	Groupwork Table Top
TS4TLDR24	328	Groupwork Table Top
TS4TLDR30	328	Groupwork Table Top
TS4TLDR36	328	Groupwork Table Top
TS4TLDR42	328	Groupwork Table Top
TS4TLDR48	328	Groupwork Table Top
TS4TLR1848	327	Groupwork Table Top
TS4TLR1860	327	Groupwork Table Top
TS4TLR1866	327	Groupwork Table Top
TS4TLR1872	327	Groupwork Table Top
TS4TLR1884	327	Groupwork Table Top
TS4TLR2424	328	Groupwork Table Top
TS4TLR2436	327	Groupwork Table Top
TS4TLR2442	327	Groupwork Table Top
TS4TLR2448	327	Groupwork Table Top
TS4TLR2460	327	Groupwork Table Top
TS4TLR2466	327	Groupwork Table Top
TS4TLR2472	327	Groupwork Table Top
TS4TLR2484	327	Groupwork Table Top
TS4TLR3030	328	Groupwork Table Top
TS4TLR3036	327	Groupwork Table Top
TS4TLR3042	327	Groupwork Table Top
TS4TLR3048	327	Groupwork Table Top
TS4TLR3060	327	Groupwork Table Top
TS4TLR3066	327	Groupwork Table Top
TS4TLR3072	327	Groupwork Table Top
TS4TLR3636	328	Groupwork Table Top
TS4TLR4242	328	Groupwork Table Top
TS4TLR4848	328	Groupwork Table Top
TS4TST	384	Skate Table
TS4TWP	383	Campfire Personal Table
TS4WIRE	332	Groupwork Wire MT
TS4WPERLNGE	337	Simple Lounge Personal Table
TS4WRD	347	Simple Working-Height Round Table
TS4WRDCAFE	356	Simple Café-Height Round Table
TS4WRDLNGE	338	Simple Lounge-Height Round Table
TS4WREC	351	Simple Working-Height Rectangle Table
TS4WRECLNGE	341	Simple Lounge-Height Rectangle Table
TS4WSFTREC	355	Simple Working-Height Soft Rectangle Table
TS4WSFTRECLNGE	345	Simple Lounge-Height Soft Rectangle Table
TS4WSFTSQ	353	Simple Working-Height Soft Square Table
TS4WSFTSQLNGE	343	Simple Lounge-Height Soft Square Table
TS4WSQ	349	Simple Working-Height Square Table
TS4WSQCAFE	357	Simple Café-Height Square Table
TS4WSQLNGE	339	Simple Lounge-Height Square Table
TS7120JB3	188	120° Jct Block
TS7120JB4	188	120° Jct Block
TS7120JB5	188	120° Jct Block
TS7120JC	189	120° Jct Cap
TS7120VA4	190	120° to V Trim Aligner
TS71218HS	199	Steel Pnl Skin

Style Number	Page	Description	Style Number	Page	Description
TS71218MB	202	MB Surf Pnl Bldp	TS712BPZ	213	Bs Pwr Infeed
TS71218TK	196	F-Cvrd Pnl Skin	TS712IPJS	176	Stck In-Line Pnl Jct
TS71224HS	199	Steel Pnl Skin	TS712T120CHT	187	120° Cor C-O-H Trim
TS71224MB	202	Mb Skin	TS712TCLCHT	186	L Cor C-O-H Trim
TS71224SPW	207	Sgl-Pane Glass Win	TS712TCTCHT	186	T Cor C-O-H Trim
TS71224TK	196	F-Cvrd Pnl Skin	TS712TEPJS	176	Stck EOR Pnl Jct
TS71224TSS	204	Stl Tech Skin	TS712TICHT	185	EOR In-Line COH Trim
TS71230HS	199	Steel Pnl Skin	TS712TLPJS	178	Stck L Pnl Jct
TS71230LTSS	204	Stl Tech Skin, LH Co	TS712TTPJS	178	Stacking T Pnl Jct
TS71230MB	202	Mb Skin	TS712TVCHT	187	V Cnr C-O-H Trim
TS71230RTSS	204	St Tech Skin, RH Co	TS712TVPJS	178	Stck V Pnl Jct
TS71230SPW	207	Sgl-Pane Glass Win	TS712UPHX	215	Mul. Pwr Infeed
TS71230TK	196	F-Cvrd Pnl Skin	TS712UPHY	215	Mul. Pwr Infeed
TS71230TSS	204	Stl Tech Skin	TS712UPHZ	215	Mul. Pwr Infeed
TS71236HS	199	Steel Pnl Skin	TS712WPJS	177	Stck Wall-Start Jct
TS71236LTSS	204	Stl Tech Skin, LH Co	TS712XPJS	178	Stck X Pnl Jct
TS71236MB	202	Mb Skin	TS712YPJS	178	Stck Y Pnl Jct
TS71236RTSS	204	Stl Tech Skin, RH Co	TS714WSP	223	U Support Plate
TS71236SPW	207	Sgl-Pane Glass Win	TS71818HS	199	Steel Pnl Skin
TS71236TK	196	F-Cvrd Pnl Skin	TS71818MB	202	MB Surf for Panel Bldp
TS71236TSS	204	Stl Tech Skin	TS71818TK	196	F-Cvrd Pnl Skin
TS71242HS	199	Steel Pnl Skin	TS71824HS	199	Steel Pnl Skin
TS71242LTSS	204	Stl Tech Skin, LH Co	TS71824MB	202	Mb Skin
TS71242MB	202	Mb Skin	TS71824SPW	207	Sgl-Pane Glass Win
TS71242RTSS	204	Stl Tech Skin, RH Co	TS71824TB	217	TB Use w/Wall Chan
TS71242SPW	207	Sgl-Pane Glass Win	TS71824TK	196	F-Cvrd Pnl Skin
TS71242TK	196	F-Cvrd Pnl Skin	TS71824TSS	205	Stl Tech Skin
TS71242TSS	204	Stl Tech Skin	TS71830HS	199	Steel Pnl Skin
TS71248HS	199	Steel Pnl Skin	TS71830LTSS	205	Stl Tech Skin, LH Co
TS71248LTSS	204	Stl Tech Skin, LH Co	TS71830MB	202	Mb Skin
TS71248MB	202	Mb Skin	TS71830RTSS	205	Stl Tech Skin, RH Co
TS71248RTSS	204	Stl Tech Skin, RH Co	TS71830SPW	207	Sgl-Pane Glass Win
TS71248SPW	207	Sgl-Pane Glass Win	TS71830TB	217	TB Use w/Wall Chan
TS71248TK	196	F-Cvrd Pnl Skin	TS71830TK	196	F-Cvrd Pnl Skin
TS71248TSS	204	Stl Tech Skin	TS71830TSS	205	Stl Tech Skin
TS71260HS	199	Steel Pnl Skin	TS71836HS	199	Steel Pnl Skin
TS71260LTSS	204	Stl Tech Skin, LH Co	TS71836LTSS	205	Stl Tech Skin, LH Co
TS71260MB	202	Mb Skin	TS71836MB	202	Mb Skin
TS71260RTSS	204	Stl Tech Skin, RH Co	TS71836RTSS	205	Stl Tech Skin, RH Co
TS71260SPW	207	Sgl-Pane Glass Win	TS71836SPW	207	Sgl-Pane Glass Win
TS71260TK	196	F-Cvrd Pnl Skin	TS71836TB	217	TB Use w/Wall Chan
TS71260TSS	204	Stl Tech Skin	TS71836TK	196	F-Cvrd Pnl Skin
TS71272HS	199	Steel Pnl Skin	TS71836TSS	205	Stl Tech Skin
TS71272LTSS	204	Stl Tech Skin, LH Co	TS71842HS	199	Steel Pnl Skin
TS71272MB	202	Mb Skin	TS71842LTSS	205	Stl Tech Skin, LH Co
TS71272RTSS	204	Stl Tech Skin, RH Co	TS71842MB	202	Mb Skin
TS71272SPW	207	Sgl-Pane Glass Win	TS71842RTSS	205	Stl Tech Skin, RH Co
TS71272TK	196	F-Cvrd Pnl Skin	TS71842SPW	207	Sgl-Pane Glass Win
TS71272TSS	204	Stl Tech Skin	TS71842TB	217	TB Use w/Wall Chan
TS71278SPW	207	Sgl-Pane Gls Win	TS71842TK	196	F-Cvrd Pnl Skin
TS71284SPW	207	Sgl-Pane Gls Win	TS71842TSS	205	Stl Tech Skin
TS71290SPW	207	Sgl-Pane Glass Win	TS71848HS	199	Steel Pnl Skin
TS71296SPW	207	Sgl-Pane Glass Win	TS71848LTSS	205	Stl Tech Skin, LH Co
TS712BPX	213	Bs Pwr Infeed	TS71848MB	202	Mb Skin
TS712BPY	213	Bs Pwr Infeed	TS71848RTSS	205	Stl Tech Skin, RH Co

Style Number Index, continued

Style Number	Page	Description
TS71848SPW	207	Sgl-Pane Glass Win
TS71848TB	217	TB Use w/Wall Chan
TS71848TK	196	F-Cvrd Pnl Skin
TS71848TSS	205	Stl Tech Skin
TS71860HS	199	Steel Pnl Skin
TS71860LTSS	205	Stl Tech Skin, LH Co
TS71860MB	202	Mb Skin
TS71860RTSS	205	Stl Tech Skin, RH Co
TS71860SPW	207	Sgl-Pane Glass Win
TS71860TB	217	TB Use w/Wall Chan
TS71860TK	196	F-Cvrd Pnl Skin
TS71860TSS	205	Stl Tech Skin
TS71872HS	199	Steel Pnl Skin
TS71872LTSS	205	Stl Tech Skin, LH Co
TS71872MB	202	Mb Skin
TS71872RTSS	205	Stl Tech Skin, RH Co
TS71872SPW	207	Sgl-Pane Glass Win
TS71872TB	217	TB Use w/Wall Chan
TS71872TK	196	F-Cvrd Pnl Skin
TS71872TSS	205	Stl Tech Skin
TS71878SPW	207	Sgl-Pane Glass Win
TS71884SPW	207	Sgl-Pane Glass Win
TS71890SPW	207	Sgl-Pane Glass Win
TS71896SPW	207	Sgl-Pane Glass Win
TS718CT	209	Cable Tray
TS718HFS	194	Stck Horiz Frame Pkg
TS718IPJS	176	Stck In-Line Pnl Jct
TS718T120CHT	187	120° Cnr C-O-H Trim
TS718TCLCHT	186	L Cnr C-O-H Trim
TS718TCTCHT	186	T Cnr C-O-H Trim
TS718TEPJS	176	Stck EOR Pnl Jct
TS718THF	193	Base Horiz Frame Pkg
TS718TICHT	185	EOR In-Line COH Trim
TS718TLPJS	178	Stck L Pnl Jct
TS718TTPJS	178	Stck T Pnl Jct
TS718TVCHT	187	V Cnr C-O-H Trim
TS718TVPJS	178	Stck V Pnl Jct
TS718WPJS	177	Stck Wall-Start Jct
TS718XPJS	178	Stck X Pnl Jct
TS718YPJS	178	Stck Y Pnl Jct
TS71SGX	212	15-Amp Duplex Rcpt
TS71SGY	212	15-Amp Duplex Rcpt
TS71SGZ	212	15-Amp Duplex Rcpt
TS71SSX	212	15-Amp Duplex Rcpt
TS71SSY	212	15-Amp Duplex Rcpt
TS71SSZ	212	15-Amp Duplex Rcpt
TS720WSP	223	U Support Plate
TS72418HS	199	Steel Pnl Skin
TS72418HSF	201	Steel To The Flr Skin
TS72418MB	202	MB Surf Pnl Bldps
TS72418TK	196	F-Cvrd Pnl Skin
TS72418TKF	197	F-Cvrd To The Flr Skin
TS72424HS	199	Steel Pnl Skin
TS72424HSF	201	Steel To The Flr Skin
TS72424MB	202	MB Skin

Style Number	Page	Description
TS72424SPW	207	Sgl-Pane Glass Win
TS72424TK	196	F-Cvrd Pnl Skin
TS72424TKF	197	F-Cvrd The Flr Skin
TS72430HS	199	Steel Pnl Skin
TS72430HSF	201	Steel To The Flr Skin
TS72430MB	202	Mb Skin
TS72430SPW	207	Sgl-Pane Glass Win
TS72430TK	196	F-Cvrd Pnl Skin
TS72430TKF	197	F-Cvrd The Flr Skin
TS72436HS	199	Steel Pnl Skin
TS72436HSF	201	Steel To The Flr Skin
TS72436MB	202	Mkd Skin
TS72436SPW	207	Sgl-Pane Glass Win
TS72436TK	196	F-Cvrd Pnl Skin
TS72436TKF	197	F-Cvrd The Flr Skin
TS72442HS	199	Steel Pnl Skin
TS72442HSF	201	Steel To The Flr Skin
TS72442MB	202	Mkd Skin
TS72442SPW	207	Sgl-Pane Gls Win
TS72442TK	196	F-Cvrd Pnl Skin
TS72442TKF	197	F-Cvrd The Flr Skin
TS72448HS	199	Steel Pnl Skin
TS72448HSF	201	Steel To The Flr Skin
TS72448MB	202	Mkd Skin
TS72448SPW	207	Sgl-Pane Glass Win
TS72448TK	196	F-Cvrd Pnl Skin
TS72448TKF	197	F-Cvrd To The Flr Skin
TS72460HS	199	Steel Pnl Skin
TS72460HSF	201	Steel To The Flr Skin
TS72460MB	202	Mkd Skin
TS72460SPW	207	Sgl-Pane Gls Win
TS72460TK	196	F-Cvrd Pnl Skin
TS72460TKF	197	F-Cvrd To The Flr Skin
TS72472HS	199	Steel Pnl Skin
TS72472HSF	201	Steel To Flr Skin
TS72472MB	202	Mkd Skin
TS72472SPW	207	Sgl-Pane Glass Win
TS72472TK	196	F-Cvrd Pnl Skin
TS72472TKF	197	F-Cvrd To The Flr Skin
TS72478SPW	207	Sgl-Pane Glass Win
TS72484SPW	207	Sgl-Pane Glass Win
TS72490SPW	207	Sgl-Pane Glass Win
TS72496SPW	207	Sgl-Pane Glass Win
TS724BKT	175	Off-Mod Pnl Conn
TS724CT	209	Cable Tray
TS724HFS	194	Stck Horiz Frame Pkg
TS724IPJS	176	Stck In-Line Pnl Jct
TS724T120CHT	187	120° Cnr C-O-H Trim
TS724TCLCHT	186	L Cnr C-O-H Trim
TS724TCTCHT	186	T Cnr C-O-H Trim
TS724TEPJS	176	Stck EOR Pnl Jct
TS724THF	193	Base Horiz Frame Pkg
TS724TICHT	185	EOR In-Line COH Trim
TS724TLPJS	178	Stacking L Pnl Jct
TS724TTPJS	178	Stacking T Pnl Jct

Style Number	Page	Description	Style Number	Page	Description
TS724TVCHT	187	V Cnr C-O-H Trim	TS730HFS	194	Stck Horz Frame Pkg
TS724TVPJS	178	Stacking V Pnl Jct	TS730JP	188	Jct Post
TS724UPHX	215	Mpp Power Infeed	TS730T120CHT	187	120° Cnr C-O-H Trim
TS724UPHY	215	Mpp Power Infeed	TS730TCLCHT	186	L Cnr C-O-H Trim
TS724UPHZ	215	Mpp Power Infeed	TS730TCTCHT	186	T Cnr C-O-H Trim
TS724WPJS	177	Stacking Wall-Start Jct	TS730TEPJ	158	EOR Base Pnl Jct
TS724XPJS	178	Stacking X Pnl Jct	TS730TEVT	182	EOR Vrtl Trim
TS724YPJS	178	Stacking Y Pnl Jct	TS730THF	193	Base Horz Frame Pkg
TS72SGX	212	15-Amp Duplex Rcpt	TS730TICHT	185	EOR In-Line COH Trim
TS72SGY	212	15-Amp Duplex Rcpt	TS730TIPJ	155	In-Line Base Pnl Jct
TS72SGZ	212	15-Amp Duplex Rcpt	TS730TLPJ	156	L Base Pnl Jct
TS72SSX	212	15-Amp Duplex Rcpt	TS730TLVT	183	L Vrtl Trim
TS72SSY	212	15-Amp Duplex Rcpt	TS730TSUC	180	Clg-Acs Lay-in Ut Pkg
TS72SSZ	212	15-Amp Duplex Rcpt	TS730TSUF	181	Flr-Acs Lay-in Util Pkg
TS73018HS	199	Steel Pnl Skin	TS730TTPJ	156	T Base Pnl Jct
TS73018HSF	201	Steel To The Flr Skin	TS730TTVT	183	T Vrtl Trim
TS73018MB	202	Mkd Surf for Pnl Bldps	TS730TVCHT	187	V Cnr C-O-H Trim
TS73018TK	196	F-Cvrd Pnl Skin	TS730TVPJ	159	V Base Pnl Jct
TS73018TKF	197	F-Cvrd To The Flr Skin	TS730TVVT	184	V Vrtl Trim
TS73024HS	199	Steel Pnl Skin	TS730TXPJ	157	X Base Pnl Jct
TS73024HSF	201	Steel To The Flr Skin	TS730TYPJ	159	Y Base Pnl Jct
TS73024MB	202	Mkd Skin	TS73334TCXJ	168	X C-O-H Jct
TS73024TK	196	F-Cvrd Pnl Skin	TS73335TCXJ	168	X C-O-H Jct
TS73024TKF	197	F-Cvrd To The Flr Skin	TS73336TCXJ	168	X C-O-H Jct
TS73030HS	199	Steel Pnl Skin	TS73338TCXJ	168	X C-O-H Jct
TS73030HSF	201	Steel To The Flr Skin	TS7333QTCXJ	168	X C-O-H Jct
TS73030TK	196	F-Cvrd Pnl Skin	TS73344TCXJ	167	X C-O-H Jct
TS73030TKF	197	F-Cvrd To The Flr Skin	TS7334TCTJ	164	T C-O-H Jct
TS73036HS	199	Steel Pnl Skin	TS73355TCXJ	167	X C-O-H Jct
TS73036HSF	201	Steel To The Flr Skin	TS7335TCTJ	164	T C-O-H Jct
TS73036MB	202	Mkd Skin	TS73366TCXJ	167	X C-O-H Jct
TS73036TK	196	F-Cvrd Pnl Skin	TS7336TCTJ	164	T C-O-H Jct
TS73036TKF	197	F-Cvrd To The Flr Skin	TS73388TCXJ	167	X C-O-H Jct
TS73042HS	199	Steel Pnl Skin	TS7338TCTJ	164	T C-O-H Jct
TS73042HSF	201	Steel To The Flr Skin	TS733QTCXJ	167	X C-O-H Jct
TS73042MB	202	Mkd Skin	TS733QTCTJ	164	T C-O-H Jct
TS73042TK	196	F-Cvrd Pnl Skin	TS73434TCXJ	166	X C-O-H Jct
TS73042TKF	197	F-Cvrd To The Flr Skin	TS7343TCTJ	162	T C-O-H Jct
TS73048HS	199	Steel Pnl Skin	TS7344TCYJ	173	Y C-O-H Jct
TS73048HSF	201	Steel To The Flr Skin	TS734TCIJ	160	In-Line C-O-H Jct
TS73048MB	202	Mkd Skin	TS734TCLJ	161	L C-O-H Jct
TS73048TK	196	F-Cvrd Pnl Skin	TS734TCVJ	170	V C-O-H Jct
TS73048TKF	197	F-Cvrd To The Flr Skin	TS73535TCXJ	166	X C-O-H Jct
TS73060HS	199	Steel Pnl Skin	TS7353TCTJ	162	T C-O-H Jct
TS73060HSF	201	Steel To The Flr Skin	TS7355TCYJ	173	Y C-O-H Jct
TS73060MB	202	Mkd Skin	TS735TCIJ	160	In-Line C-O-H Jct
TS73060TK	196	F-Cvrd Pnl Skin	TS735TCLJ	161	L C-O-H Jct
TS73060TKF	197	F-Cvrd To The Flr Skin	TS735TCVJ	170	V C-O-H Jct
TS73072HS	199	Steel Pnl Skin	TS73618HS	199	Steel Pnl Skin
TS73072HSF	201	Steel To The Flr Skin	TS73618HSF	201	Steel To The Flr Skin
TS73072MB	202	Mkd Skin	TS73618MB	202	Mkd Surf for Pnl Bldps
TS73072TK	196	F-Cvrd Pnl Skin	TS73618TK	196	F-Cvrd Pnl Skin
TS73072TKF	197	F-Cvrd To The Flr Skin	TS73618TKF	197	F-Cvrd To The Flr Skin
TS730BKT	175	Off-Mod Pnl Conn	TS73624HS	199	Steel Pnl Skin
TS730CT	209	Cable Tray	TS73624HSF	201	Steel To The Flr Skin

Style Number Index, continued

Style Number	Page	Description
TS73624MB	202	Mkd Skin
TS73624TK	196	F-Cvrd Pnl Skin
TS73624TKF	197	F-Cvrd To The Flr Skin
TS73630HS	199	Steel Pnl Skin
TS73630HSF	201	Steel To The Flr Skin
TS73630MB	202	Mkd Skin
TS73630TK	196	F-Cvrd Pnl Skin
TS73630TKF	197	F-Cvrd To The Flr Skin
TS73636HS	199	Steel Pnl Skin
TS73636HSF	201	Steel To The Flr Skin
TS73636MB	202	Mkd Skin
TS73636TCXJ	166	X C-O-H Jct
TS73636TK	196	F-Cvrd Pnl Skin
TS73636TKF	197	F-Cvrd To The Flr Skin
TS7363TCTJ	162	T C-O-H Jct
TS73642HS	199	Steel Pnl Skin
TS73642HSF	201	Steel To The Flr Skin
TS73642MB	202	Mkd Skin
TS73642TK	196	F-Cvrd Pnl Skin
TS73642TKF	197	F-Cvrd To The Flr Skin
TS73648HS	199	Steel Pnl Skin
TS73648HSF	201	Steel To The Flr Skin
TS73648MB	202	Mkd Skin
TS73648TK	196	F-Cvrd Pnl Skin
TS73648TKF	197	F-Cvrd To The Flr Skin
TS73660HS	199	Steel Pnl Skin
TS73660HSF	201	Steel To The Flr Skin
TS73660MB	202	Mkd Skin
TS73660TK	196	F-Cvrd Pnl Skin
TS73660TKF	197	F-Cvrd To The Flr Skin
TS7366TCYJ	173	Y C-O-H Jct
TS73672HS	199	Steel Pnl Skin
TS73672HSF	201	Steel To The Flr Skin
TS73672MB	202	Mkd Skin
TS73672TK	196	F-Cvrd Pnl Skin
TS73672TKF	197	F-Cvrd To The Flr Skin
TS736BKT	175	Off-Mdle Pnl Conntor
TS736CT	209	Cable Tray
TS736HFS	194	Stcking Horiz Frm Pkg
TS736JP	188	Jct Post
TS736T120CHT	187	120° Cnr C-O-H Trim
TS736TCIJ	160	In-Line C-O-H Jct
TS736TCLCHT	186	L Cnr C-O-H Trim
TS736TCLJ	161	L C-O-H Jct
TS736TCTCHT	186	T Cnr C-O-H Trim
TS736TCVJ	170	V C-O-H Jct
TS736TEPJ	158	EOR Base Pnl Jct
TS736TEPJS	176	Stk EOR Pnl Jct
TS736TEVT	182	EOR Vrtl Trim
TS736THF	193	Base Horiz Frame Pkg
TS736TICHT	185	EOR In-Line COH Trim
TS736TIPJ	155	In-Line Base Pnl Jct
TS736TLPJ	156	L Base Pnl Jct
TS736TLVT	183	L Vrtl Trim
TS736TSUC	180	Clg-Acs Lay-in Utl Pkg

Style Number	Page	Description
TS736TSUF	181	Flr-Acs Lay-in Utl Pkg
TS736TTC	195	Spanning Top Cap
TS736TTPJ	156	L Base Pnl Jct
TS736TTVT	183	T Vrtl Trim
TS736TVCHT	187	V Cnr C-O-H Trim
TS736TVPJ	159	V Base Pnl Jct
TS736TVVT	184	V Vrtl Trim
TS736TXPJ	157	X Base Pnl Jct
TS736TYPJ	159	V and Y Base Pnl Jct
TS736WPJ	174	Wall-Start Jct
TS73838TCXJ	166	X C-O-H Jct
TS7383TCTJ	162	T C-O-H Jct
TS7388TCVJ	173	Y C-O-H Jct
TS738TCIJ	160	In-Line C-O-H Jct
TS738TCLJ	161	L C-O-H Jct
TS738TCVJ	170	V C-O-H Jct
TS73Q3QTCXJ	166	EOR Base Pnl Jct
TS73Q3TCTJ	162	T C-O-H Jct
TS73QQTCYJ	173	Y C-O-H Jct
TS73QTCIJ	160	I C-O-H Jct
TS73QTCLJ	161	L C-O-H Jct
TS73QTCVJ	170	V C-O-H Jct
TS73SGX	212	15-Amp Duplex Rcpt
TS73SGY	212	15-Amp Duplex Rcpt
TS73SGZ	212	15-Amp Duplex Rcpt
TS73SSX	212	15-Amp Duplex Rcpt
TS73SSY	212	15-Amp Duplex Rcpt
TS73SSZ	212	15-Amp Duplex Rcpt
TS74218TK	196	F-Cvrd Pnl Skin
TS74218TKF	197	F-Cvrd To The Flr Skin
TS74224TK	196	F-Cvrd Pnl Skin
TS74224TKF	197	F-Cvrd To The Flr Skin
TS74230TK	196	F-Cvrd Pnl Skin
TS74230TKF	197	F-Cvrd To The Flr Skin
TS74236TK	196	F-Cvrd Pnl Skin
TS74236TKF	197	F-Cvrd To The Flr Skin
TS74242TK	196	F-Cvrd Pnl Skin
TS74242TKF	197	F-Cvrd To The Flr Skin
TS74248TK	196	F-Cvrd Pnl Skin
TS74248TKF	197	F-Cvrd To The Flr Skin
TS74260TK	196	F-Cvrd Pnl Skin
TS74260TKF	197	F-Cvrd To The Flr Skin
TS74272TK	196	F-Cvrd Pnl Skin
TS74272TKF	197	F-Cvrd To The Flr Skin
TS742BKT	175	Off-Mod Pnl Conn
TS742CT	209	Cable Tray
TS742HB	414	Horiz Brace
TS742HFS	194	Stcking Horiz Frm Pkg
TS742JP	188	Jct Post
TS742TEPJ	158	EOR Base Pnl Jct
TS742TEVT	182	EOR Vrtl Trim
TS742THF	193	Base Horiz Frame Pkg
TS742TIPJ	155	In-Line Base Pnl Jct
TS742TLPJ	156	L Base Pnl Jct
TS742TLVT	183	L Vrtl Trim

Style Number	Page	Description	Style Number	Page	Description
TS742TSUC	180	Clg-Acs Lay-in Util Pkg	TS74836TK	196	F-Cvrd Pnl Skin
TS742TSUF	181	Flr-Acs Lay-in Util Pkg	TS74836TKF	197	F-Cvrd To The Flr Skin
TS742TTC	195	Spanning Top Cap	TS74842TK	196	F-Cvrd Pnl Skin
TS742TTPJ	156	T Base Pnl Jct	TS74842TKF	197	F-Cvrd To The Flr Skin
TS742TTVT	183	T Vrtl Trim	TS74848TCXJ	166	X C-O-H Jct
TS742TVPJ	159	V Base Pnl Jct	TS74848TK	196	F-Cvrd Pnl Skin
TS742TVVT	184	V Vrtl Trim	TS74848TKF	197	F-Cvrd To The Flr Skin
TS742TXPJ	157	X Base Pnl Jct	TS7484TCTJ	162	T C-O-H Jct
TS742TYPJ	159	Y Base Pnl Jct	TS74860TK	196	F-Cvrd Pnl Skin
TS742WPJ	174	Wall-Start Jct	TS74860TKF	197	F-Cvrd To The Flr Skin
TS7433TCYJ	172	Y C-O-H Jct	TS74872TK	196	F-Cvrd Pnl Skin
TS7434TCTJ	163	T C-O-H Jct	TS74872TKF	197	F-Cvrd To The Flr Skin
TS743MHX	216	Modular Harness	TS7488TCYJ	173	Y C-O-H Jct
TS743MHY	216	Modular Harness	TS748BKT	175	Off-Mod Pnl Conntor
TS743MHZ	216	Modular Harness	TS748CT	209	Cable Tray
TS7443TCTJ	165	T C-O-H Jct	TS748HB	414	Horiz Brace
TS74443TCXJ	169	X C-O-H Jct	TS748HFS	194	Stck Horiz Frame Pkg
TS74445TCXJ	168	X C-O-H Jct	TS748JP	188	Jct Post
TS74446TCXJ	168	X C-O-H Jct	TS748TCIJ	160	In-Line C-O-H Jct
TS74447TCXJ	168	X C-O-H Jct	TS748TCLJ	161	In-Line C-O-H Jct
TS74448TCXJ	168	X C-O-H Jct	TS748TCVJ	170	V C-O-H Jct
TS7444QTCXJ	169	X C-O-H Jct	TS748TEPJ	158	EOR Base Pnl Jct
TS74455TCXJ	167	X C-O-H Jct	TS748TEVT	182	EOR Vrtl Trim
TS7445TCTJ	164	T C-O-H Jct	TS748THF	193	Base Horiz Frame Pkg
TS74466TCXJ	167	X C-O-H Jct	TS748TIPJ	155	In-Line Base Pnl Jct
TS7446TCTJ	164	T C-O-H Jct	TS748TLPJ	156	L Base Pnl Jct
TS74477TCXJ	167	X C-O-H Jct	TS748TLVT	183	L Vrtl Trim
TS7447TCTJ	164	T C-O-H Jct	TS748TSUC	180	C-A Lay-in Util Pkg
TS74488TCXJ	167	T C-O-H Jct	TS748TSUF	181	F-A Lay-in Util Pkg
TS7448TCTJ	164	T C-O-H Jct	TS748TTC	195	Spanning Top Cap
TS744QTCTJ	165	T C-O-H Jct	TS748TTPJ	156	T Base Pnl Jct
TS74545TCXJ	166	X C-O-H Jct	TS748TTVT	183	T Vrtl Trim
TS7454TCTJ	162	T C-O-H Jct	TS748TVPJ	159	V Base Pnl Jct
TS7455TCYJ	173	Y C-O-H Jct	TS748TVVT	184	V Vrtl Trim
TS745TCIJ	160	In-Line C-O-H Jct	TS748TXPJ	157	X Base Pnl Jct
TS745TCLJ	161	L C-O-H Jct	TS748TYPJ	159	Y Base Pnl Jct
TS745TCVJ	170	V C-O-H Jct	TS748WPJ	174	Wall-Start Jct
TS74646TCXJ	166	X C-O-H Jct	TS74Q4TCTJ	163	T C-O-H Jct
TS7464TCTJ	162	T C-O-H Jct	TS74QQTCYJ	172	Y C-O-H Jct
TS7466TCYJ	173	Y C-O-H Jct	TS74SGX	212	15-Amp Duplex Rcpt
TS746TCIJ	160	In-Line C-O-H Jct	TS74SGY	212	15-Amp Duplex Rcpt
TS746TCLJ	161	L C-O-H Jct	TS74SSX	212	15-Amp Duplex Rcpt
TS746TCVJ	170	V C-O-H Jct	TS74SSY	212	15-Amp Duplex Rcpt
TS74747TCXJ	166	X C-O-H Jct	TS7533TCYJ	172	Y C-O-H Jct
TS7474TCTJ	162	T C-O-H Jct	TS7535TCTJ	163	T C-O-H Jct
TS7477TCYJ	173	Y C-O-H Jct	TS7544TCYJ	172	Y C-O-H Jct
TS747TCIJ	160	In-Line C-O-H Jct	TS7545TCTJ	163	T C-O-H Jct
TS747TCLJ	161	L C-O-H Jct	TS754ICLS	189	Inside Cnr Light Seal
TS747TCVJ	170	V C-O-H Jct	TS754JP	188	Jct Post
TS74818TK	196	F-Cvrd Pnl Skin	TS754TEPJ	158	EOR Base Pnl Jct
TS74818TKF	197	F-Cvrd To The Flr Skin	TS754TEVT	182	EOR Vrtl Trim
TS74824TK	196	F-Cvrd Pnl Skin	TS754TIPJ	155	In-Line Base Pnl Jct
TS74824TKF	197	F-Cvrd To The Flr Skin	TS754TLPJ	156	L Base Pnl Jct
TS74830TK	196	F-Cvrd Pnl Skin	TS754TLVT	183	L Vrtl Trim
TS74830TKF	197	F-Cvrd To The Flr Skin	TS754TTC	195	Spanning Top Cap

Style Number Index, continued

Style Number	Page	Description
TS754TTPJ	156	T Base Pnl Jct
TS754TTVT	183	T Vrtl Trim
TS754TVPJ	159	V Base Pnl Jct
TS754TVVT	184	V Vrtl Trim
TS754TXPJ	157	X Base Pnl Jct
TS754TYPJ	159	Y Base Pnl Jct
TS754WPJ	174	Wall-Start Jct
TS7553TCTJ	165	T C-O-H Jct
TS7554TCTJ	165	T C-O-H Jct
TS75553TCXJ	169	X C-O-H Jct
TS75554TCXJ	169	X C-O-H Jct
TS75556TCXJ	168	X C-O-H Jct
TS75557TCXJ	168	X C-O-H Jct
TS75558TCXJ	169	X C-O-H Jct
TS7555QTCXJ	169	X C-O-H Jct
TS75566TCXJ	167	X C-O-H Jct
TS7556TCTJ	164	T C-O-H Jct
TS75577TCXJ	167	X C-O-H Jct
TS7557TCTJ	164	T C-O-H Jct
TS7558TCTJ	165	T C-O-H Jct
TS755QTCTJ	165	T C-O-H Jct
TS75656TCXJ	166	X C-O-H Jct
TS7565TCTJ	162	T C-O-H Jct
TS7566TCYJ	173	Y C-O-H Jct
TS756TCIJ	160	In-Line C-O-H Jct
TS756TCLJ	161	L C-O-H Jct
TS756TCVJ	170	V C-O-H Jct
TS75757TCXJ	166	X C-O-H Jct
TS7575TCTJ	162	T C-O-H Jct
TS7577TCYJ	173	Y C-O-H Jct
TS7577TCIJ	160	In-Line C-O-H Jct
TS7577TCLJ	161	L C-O-H Jct
TS7577TCVJ	170	V C-O-H Jct
TS7585TCTJ	163	T C-O-H Jct
TS7588TCYJ	172	Y C-O-H Jct
TS759TCIJ	160	In-Line C-O-H Jct
TS7595TCTJ	163	T C-O-H Jct
TS759QTCYJ	172	T C-O-H Jct
TS76018TK	196	F-Cvrd Pnl Skin
TS76018TKF	197	F-Cvrd To The Flr Skin
TS76024TK	196	F-Cvrd Pnl Skin
TS76024TKF	197	F-Cvrd To The Flr Skin
TS76030TK	196	F-Cvrd Pnl Skin
TS76030TKF	197	F-Cvrd To The Flr Skin
TS76036TK	196	F-Cvrd Pnl Skin
TS76036TKF	197	F-Cvrd To The Flr Skin
TS76042TK	196	F-Cvrd Pnl Skin
TS76042TKF	197	F-Cvrd To The Flr Skin
TS76048TK	196	F-Cvrd Pnl Skin
TS76048TKF	197	F-Cvrd To The Flr Skin
TS76060TK	196	F-Cvrd Pnl Skin
TS76060TKF	197	F-Cvrd To The Flr Skin
TS76072TK	196	F-Cvrd Pnl Skin
TS760BKT	175	Off-Mod Pnl Connect
TS760CT	209	Cable Tray

Style Number	Page	Description
TS760HB	414	Horiz Brace
TS760HFS	194	Stacking Horiz Fr Pkg
TS760TEVT	182	EOR Vrtl Trim
TS760THF	193	Base Horiz Frame Pkg
TS760TLVT	183	L Vrtl Trim
TS760TTC	195	Spanning Top Cap
TS760TTVT	183	T Vrtl Trim
TS760TVVT	184	V Vrtl Trim
TS7624HS	204	Stl Tech Skin, No Co
TS7624TSS	204	Steel Tech Skin
TS7630HS	204	Stl Tech Skin, No Co
TS7630LTSS	204	Stl Tech Skin, LH Co
TS7630RTSS	204	Stl Tech Skin, RH Co
TS7630TSS	204	Steel Tech Skin
TS7633TCYJ	172	Y C-O-H Jct
TS7636HS	204	Stl Tech Skin, No Co
TS7636LTSS	204	Stl Tech Skin, LH Co
TS7636RTSS	204	Stl Tech Skin, RH Co
TS7636TCTJ	163	T C-O-H Jct
TS7636TSS	204	Steel Tech Skin
TS7642HS	204	Stl Tech Skin, No Co
TS7642LTSS	204	Stl Tech Skin, LH Co
TS7642RTSS	204	Stl Tech Skin, RH Co
TS7642TSS	204	Steel Tech Skin
TS7644TCYJ	172	Y C-O-H Jct
TS7646TCTJ	163	T C-O-H Jct
TS7648HS	204	Stl Tech Skin, No Co
TS7648LTSS	204	Stl Tech Skin, LH Co
TS7648RTSS	204	Stl Tech Skin, RH Co
TS7648TSS	204	Steel Tech Skin
TS7655TCYJ	172	Y C-O-H Jct
TS7656TCTJ	163	T C-O-H Jct
TS7660HS	204	Stl Tech Skin, No Co
TS7660LTSS	204	Stl Tech Skin, LH Co
TS7660RTSS	204	Stl Tech Skin, RH Co
TS7660TSS	204	Steel Tech Skin
TS7663TCTJ	165	T C-O-H Jct
TS7664TCTJ	165	T C-O-H Jct
TS7665TCTJ	165	T C-O-H Jct
TS76663TCXJ	169	X C-O-H Jct
TS76664TCXJ	169	X C-O-H Jct
TS76665TCXJ	169	X C-O-H Jct
TS76667TCXJ	168	X C-O-H Jct
TS76668TCXJ	169	X C-O-H Jct
TS7666QTCXJ	169	X C-O-H Jct
TS76677TCXJ	167	X C-O-H Jct
TS7667TCTJ	164	T C-O-H Jct
TS7668TCTJ	165	T C-O-H Jct
TS766ICLS	189	Inside Cnr Light Seal
TS766JP	188	Jct Post
TS766QTCTJ	165	T C-O-H Jct
TS766TEPJ	158	EOR Base Pnl Jct
TS766TEVT	182	EOR Vrtl Trim
TS766TIPJ	155	In-Line Base Pnl Jct
TS766TLPJ	156	L Base Pnl Jct

Style Number	Page	Description	Style Number	Page	Description
TS766TLVT	183	L Vrtl Trim	TS77775TCXJ	169	X C-O-H Jct
TS766TTC	195	Spanning Top Cap	TS77776TCXJ	169	X C-O-H Jct
TS766TTPJ	156	T Base Pnl Jct	TS77778TCXJ	169	X C-O-H Jct
TS766TTVT	183	T Vrtl Trim	TS7778TCTJ	165	T C-O-H Jct
TS766TVPJ	159	V Base Pnl Jct	TS7787TCTJ	163	T C-O-H Jct
TS766TVVT	184	V Vertical Trim	TS7788TCYJ	172	Y C-O-H Jct
TS766TXPJ	157	X Base Pnl Jct	TS778ICLS	189	Inside Cnr Light Seal
TS766TYPJ	159	Y Base Pnl Jct	TS778JP	188	Jct Post
TS766WPJ	174	Wall-Start Jct	TS778TEPJ	158	EOR Base Pnl Jct
TS7672HS	204	Stl Tech Skin, No Co	TS778TEVT	182	EOR Vrtl Trim
TS7672LTSS	204	Stl Tech Skin, LH Co	TS778TIPJ	155	In-Line Base Pnl Jct
TS7672RTSS	204	Stl Tech Skin, RH Co	TS778TLPJ	156	L Base Pnl Jct
TS7672TSS	204	Steel Tech Skin	TS778TLVT	183	L Vrtl Trim
TS76767TCXJ	166	X C-O-H Jct	TS778TTC	195	Spanning Top Cap
TS7676TCTJ	162	T C-O-H Jct	TS778TTPJ	156	T Base Pnl Jct
TS7677TCYJ	173	Y C-O-H Jct	TS778TTVT	183	T Vrtl Trim
TS7677TCIJ	160	In-Line C-O-H Jct	TS778TVPJ	159	V Base Pnl Jct
TS7677TCLJ	161	L C-O-H Jct	TS778TVVT	184	V Vertical Trim
TS7677TCVJ	170	V C-O-H Jct	TS778TXPJ	157	X Base Pnl Jct
TS7686TCTJ	163	T C-O-H Jct	TS778TYPJ	159	Y Base Pnl Jct
TS7688TCYJ	172	Y C-O-H Jct	TS778WPJ	174	Wall-Start Jct
TS7697TCIJ	160	In-Line C-O-H Jct	TS7797TCIJ	160	In-Line C-O-H Jct
TS76BPX	213	Base Power Infeed	TS780MHX	216	Modular Harness
TS76BPY	213	Base Power Infeed	TS780MHY	216	Modular Harness
TS76BPZ	213	Base Power Infeed	TS780MHZ	216	Modular Harness
TS76Q6TCTJ	163	T C-O-H Jc	TS7833TCYJ	172	Y C-O-H Jct
TS76Q6TCYJ	172	T C-O-H Jc	TS7838TCTJ	163	T C-O-H Jct
TS76T120CHT	187	120° Cor C-O-H Trim	TS7844TCYJ	172	Y C-O-H Jct
TS76TCLCHT	186	L Cor C-O-H Trim	TS7848TCTJ	163	T C-O-H Jct
TS76TCTCHT	186	T Cor C-O-H Trim	TS784TEVT	182	EOR Vrtl Trim
TS76TICHT	185	EOR In-Line COH Trim	TS784TLVT	183	L Vrtl Trim
TS76TVCHT	187	V Cnr C-O-H Trim	TS784TTC	195	Spanning Top Cap
TS76UPHX	215	Mpp Power Infeed	TS784TTVT	183	T Vrtl Trim
TS76UPHY	215	Mpp Power Infeed	TS784TVVT	184	V Vrtl Trim
TS76UPHZ	215	Mpp Power Infeed	TS7855TCYJ	173	Y C-O-H Jct
TS772BKCT	175	Off-Mod Pnl Connect	TS78585TCXJ	166	X C-O-H Jct
TS772CT	209	Cable Tray	TS7858TCTJ	162	T C-O-H Jct
TS772HB	414	Horiz Brace	TS785TCIJ	160	In-Line C-O-H Jct
TS772HFS	194	Stacking Horiz Fm Pkg	TS785TCLJ	161	L C-O-H Jct
TS772TEVT	182	EOR Vrtl Trim	TS785TCVJ	170	V C-O-H Jct
TS772THF	193	Base Horiz Frame Pkg	TS7866TCYJ	173	Y C-O-H Jct
TS772TLVT	183	L Vrtl Trim	TS78686TCXJ	166	X C-O-H Jct
TS772TTC	195	Spanning Top Cap	TS7868TCTJ	162	T C-O-H Jct
TS772TTVT	183	T Vrtl Trim	TS786TCIJ	160	In-Line C-O-H Jct
TS772TVVT	184	V Vrtl Trim	TS786TCLJ	161	L C-O-H Jct
TS7744TCYJ	172	Y C-O-H Jct	TS786TCVJ	170	V C-O-H Jct
TS7747TCTJ	163	T C-O-H Jct	TS7877TCYJ	173	Y C-O-H Jct
TS7755TCYJ	172	Y C-O-H Jct	TS78787TCXJ	166	X C-O-H Jct
TS7757TCTJ	163	T C-O-H Jct	TS7878TCTJ	162	T C-O-H Jct
TS7766TCYJ	172	Y C-O-H Jct	TS787TCLJ	161	L C-O-H Jct
TS7767TCTJ	163	T C-O-H Jct	TS787TCVJ	170	V C-O-H Jct
TS7774TCTJ	165	T C-O-H Jct	TS7883TCTJ	165	T C-O-H Jct
TS7775TCTJ	165	T C-O-H Jct	TS7884TCTJ	165	T C-O-H Jct
TS7776TCTJ	165	T C-O-H Jct	TS78855TCXJ	167	X C-O-H Jct
TS77774TCXJ	169	X C-O-H Jct	TS7885TCTJ	164	T C-O-H Jct

Style Number Index, continued

Style Number	Page	Description
TS78866TCXJ	167	X C-O-H Jct
TS7886TCTJ	164	T C-O-H Jct
TS78877TCXJ	167	X C-O-H Jct
TS7887TCTJ	164	T C-O-H Jct
TS78883TCXJ	169	X C-O-H Jct
TS78884TCXJ	169	X C-O-H Jct
TS78885TCXJ	168	X C-O-H Jct
TS78886TCXJ	168	X C-O-H Jct
TS78887TCXJ	168	X C-O-H Jct
TS7888QTCXJ	169	X C-O-H Jct
TS788QTCTJ	165	T C-O-H Jct
TS78Q8TCTJ	163	T C-O-H Jct
TS78QQTCYJ	172	Y C-O-H Jct
TS790COHJC	189	90° C-O-H Jct Cap
TS790JB3	188	90° Jct Block, Pkg of 3
TS790JB4	188	90° Jct Block, Pkg of 4
TS790JB5	188	90° Jct Block, Pkg of 5
TS790JC	189	90° Cnr Jct Cap
TS790TEVT	182	EOR Vrtl Trim
TS790TLVT	183	L Vrtl Trim
TS790TTC	195	Spanning Top Cap
TS790TTVT	183	T Vrtl Trim
TS790TVVT	184	V Vrtl Trim
TS796TTC	195	Spanning Top Cap
TS7BSWHC	414	Wall Channels
TS7CJCA10	190	Jct Cap Cnr Aligner
TS7CPK24	214	Hardwired Pwrkit
TS7CPK30	214	Hardwired Pwrkit
TS7CPK36	214	Hardwired Pwrkit
TS7CPK42	214	Hardwired Pwrkit
TS7CPK48	214	Hardwired Pwrkit
TS7CPK60	214	Hardwired Pwrkit
TS7CPK72	214	Hardwired Pwrkit
TS7LTA4	190	L to T Trim Aligner
TS7PK24X	210	4-Cir, 3+1 Wrg, Pwrkit
TS7PK24Y	210	4-Cir, 2+2 Wrg, Pwrkt
TS7PK24Z	210	3-Cir, 3SN Wrg, Pwrkt
TS7PK30X	210	4-Cir, 3+1 Wrg, Pwrkit
TS7PK30Y	210	4-Cir, 2+2 Wrg, Pwrkt
TS7PK30Z	210	3-Cir, 3SN Wrg, Pwrkt
TS7PK36X	210	4-Cir, 3+1 Wrg, Pwrkit
TS7PK36Y	210	4-Cir, 2+2 Wrg, Pwrkt
TS7PK36Z	210	3-Cir, 3SN Wrg, Pwrkt
TS7PK42X	210	4-Cir, 3+1 Wrg, Pwrkit
TS7PK42Y	210	4-Cir, 2+2 Wrg, Pwrkt
TS7PK42Z	210	3-Cir, 3SN Wrg, Pwrkt
TS7PK48X	210	4-Cir, 3+1 Wrg, Pwrkit
TS7PK48Y	210	4-Cir, 2+2 Wrg, Pwrkt
TS7PK48Z	210	3-Cir, 3SN Wrg, Pwrkt
TS7PK60X	210	4-Cir, 3+1 Wrg, Pwrkit
TS7PK60Y	210	4-Cir, 2+2 Wrg, Pwrkt
TS7PK60Z	210	3-Cir, 3SN Wrg, Pwrkt
TS7PK72X	210	4-Cir, 3+1 Wrg, Pwrkit
TS7PK72Y	210	4-Cir, 2+2 Wrg, Pwrkt
TS7PK72Z	210	3-Cir, 3SN Wrg, Pwrkt

Style Number	Page	Description
TS7PT18X	211	4-Cir, 3+1, P-T Pwrkt
TS7PT18Y	211	4-Cir, 2+2, P-T Pwrkt
TS7PT18Z	211	3-Cir, 3SN, P-T Pwrkt
TS7PT24X	211	4-Cir, 3+1, P-T Pwrkt
TS7PT24Y	211	4-Cir, 2+2, P-T Pwrkt
TS7PT24Z	211	3-Cir, 3SN, P-T Pwrkt
TS7PT30X	211	4-Cir, 3+1, P-T Pwrkt
TS7PT30Y	211	4-Cir, 2+2, P-T Pwrkt
TS7PT30Z	211	3-Cir, 3SN, P-T Pwrkt
TS7PT36X	211	4-Cir, 3+1, P-T Pwrkt
TS7PT36Y	211	4-Cir, 2+2, P-T Pwrkt
TS7PT36Z	211	3-Cir, 3SN, P-T Pwrkt
TS7PT42X	211	4-Cir, 3+1, P-T Pwrkt
TS7PT42Y	211	4-Cir, 2+2, P-T Pwrkt
TS7PT42Z	211	3-Cir, 3SN, P-T Pwrkt
TS7PT48X	211	4-Cir, 3+1, P-T Pwrkt
TS7PT48Y	211	4-Cir, 2+2, P-T Pwrkt
TS7PT48Z	211	3-Cir, 3SN, P-T Pwrkt
TS7PT60X	211	4-Cir, 3+1, P-T Pwrkt
TS7PT60Y	211	4-Cir, 2+2, P-T Pwrkt
TS7PT60Z	211	3-Cir, 3SN, P-T Pwrkt
TS7PT72X	211	4-Cir, 3+1, P-T Pwrkt
TS7PT72Y	211	4-Cir, 2+2, P-T Pwrkt
TS7PT72Z	211	3-Cir, 3SN, P-T Pwrkt
TS7PVWM	415	Vertical Wire Mgr
TS7Q33TCYJ	172	Y C-O-H Jct
TS7Q3QTCTJ	163	T C-O-H Jct
TS7Q44TCYJ	173	Y C-O-H Jct
TS7Q4Q4TCXJ	166	X C-O-H Jct
TS7Q4QTCTJ	162	L C-O-H Jct
TS7Q4TCIJ	160	I C-O-H Jct
TS7Q4TCLJ	161	L C-O-H Jct
TS7Q4TCVJ	170	V C-O-H Jct
TS7Q55TCYJ	173	Y C-O-H Jct
TS7Q5Q5TCXJ	166	X C-O-H Jct
TS7Q5QTCTJ	162	T C-O-H Jct
TS7Q5TCIJ	160	I C-O-H Jct
TS7Q5TCLJ	161	L C-O-H Jct
TS7Q5TCVJ	170	V C-O-H Jct
TS7Q66TCYJ	173	Y C-O-H Jct
TS7Q6Q6TCXJ	166	X C-O-H Jct
TS7Q6QTCTJ	162	T C-O-H Jct
TS7Q6TCIJ	160	I C-O-H Jct
TS7Q6TCLJ	161	L C-O-H Jct
TS7Q6TCVJ	170	V C-O-H Jct
TS7Q88TCYJ	173	Y C-O-H Jct
TS7Q8Q8TCXJ	166	X C-O-H Jc
TS7Q8QTCTJ	162	T C-O-H Jct
TS7Q8TCIJ	160	I C-O-H Jct
TS7Q8TCLJ	161	L C-O-H Jct
TS7Q8TCVJ	170	V C-O-H Jct
TS7QQ3TCTJ	165	T C-O-H Jct
TS7QQ44TCXJ	167	X C-O-H Jct
TS7QQ4TCTJ	164	T C-O-H Jct
TS7QQ55TCXJ	167	X C-O-H Jct

Style Number	Page	Description	Style Number	Page	Description
TS7QQ5TCTJ	164	T C-O-H Jct	UFC30T	227	FO Closed Loop
TS7QQ66TCXJ	167	X C-O-H Jct	UFH24LHANS	227	FO Half Loop
TS7QQ6TCTJ	164	T C-O-H Jct	UFH24RHANS	227	FO Half Loop
TS7QQ88TCXJ	167	X C-O-H Jct	UFH30LHANS	227	FO Half Loop
TS7QQ8TCTJ	164	T C-O-H Jct	UFH30RHANS	227	FO Half Loop
TS7QQQ3TCXJ	169	X C-O-H Jct	UFP	227	FO Post Loop
TS7QQQ4TCXJ	168	X C-O-H Jct	UFQ24	227	FO Open Loop
TS7QQQ5TCXJ	168	X C-O-H Jct	UFQ24LHANS	227	FO Open Loop
TS7QQQ6TCXJ	168	X C-O-H Jct	UFQ24RHANS	227	FO Open Loop
TS7QQQ8TCXJ	168	X C-O-H Jct	UFQ24T	227	FO Open Loop
TS7STLS1	208	Top Cap Light Seal	UFQ30LHANS	227	FO Open Loop
TS7STLS10	208	Top Cap Light Seal	UFQ30RHANS	227	FO Open Loop
TS7SWS	208	Spnig Win In-Line Sup	UFQ30T	227	FO Open Loop
TS7TIEPLATE	224	U Tie Plates	UFS1610H	227	FO Inter Support
TS7TJUP	179	L, T, or X Jct Util Pole	UFS1615H	227	FO Inter Support
TS7TSCFD	206	Tech Skin Cover Filler	UHDPL	228	U Dbl Post Leg
TS7TSCFS	206	Tech Skin Cover Filler	UHPL	228	U Post Leg
TS7TSCOVER	206	Tech Skin Cover	UNPL	228	U Post Leg
TS7UFPLATE	213	Face Plate	UNPL4	228	U Post Leg
TS7WKSPT	224	Reinforcing Chan	UNPL4C	228	U Post Leg
TS7WKSPT39	224	Reinforcing Chan	UNPLC	228	U Post Leg
TS7WKSPT48	224	Reinforcing Chan	UPL	228	U Post Leg
TS7WKSPT51	224	Reinforcing Chan	UPL4	228	U Post Leg
TS7WKSPT54	224	Reinforcing Chan	UPL4C	228	U Post Leg
TS7WKSPT60	224	Reinforcing Chan	UPL4M	228	U Post Leg
TS7WKSPT63	224	Reinforcing Chan	UPLC	228	U Post Leg
TS7WKSPT66	224	Reinforcing Chan	USSBR	223	U Side Supp Brkt
TS7WKSPT72	224	Reinforcing Chan	USWS	221	U Str WS PM
TS7WWM	229	U WS Wire Mgr	VE36	450	Easel
TSAEGROM	222	Grommet Pkg	VTC1960	367	Chevron Table
TSATRC57	358	Reinforcing Channel	VTC2460	367	Chevron Table
TSAVNBC	145	Simple Back Cushion	VTR1960	371	Rectangle Table
TSAVNCH	142	Simple Chair	VTR2460	371	Rectangle Table
TSAVNS1	146	Simple Relaxed Slipcover	VTR2472	371	Rectangle Table
TSAVNS2	147	Simple Tailored Slipcover	VTR3060	371	Rectangle Table
TSAVNSC	144	Simple Seat Cushion	VTR3072	371	Rectangle Table
TSAVNST	143	Simple Stool	VTT2460	368	Team Table
UCANT	223	U On-Mod CANT	VWB2	449	Personal Whiteboard
UCL	228	U Dbl Post C-Leg	VWT6	451	Wall Track
UCOL	229	Column	VWT8	451	Wall Track
UCSP	225	U On-Md Cen Sprt Pnl	VWTH	451	Wall Track
UCSPS	225	U On-Md Cen Sprt Pnl			
UDPL	228	U Dbl Post Leg			
UEP24	225	U On-Module End Pnl			
UEP24S	225	U On-Module End Pnl			
UEP30	225	U On-Module End Pnl			
UEP30S	225	U On-Module End Pnl			
UFB	226	Flush-Mount Bracket			
UFC24	227	FO Closed Loop			
UFC24LHANS	227	FO Closed Loop			
UFC24RHANS	227	FO Closed Loop			
UFC24T	227	FO Closed Loop			
UFC30	227	FO Closed Loop			
UFC30LHANS	227	FO Open Loop			
UFC30RHANS	227	FO Open Loop			

Trademark List

™/® The following is a non-exhaustive list of trademarks and registered trademarks for products of Steelcase Inc. or one of its related corporate entities: Agree, Airtouch, Aisla, Alight, Amia, Answer, Apprise, Aspekt, Avenir, Await, B-Free, Ballet, Bassline, Bindu, Bivi, Bix, Bottomline, Brody, Buoy, Cachet, Campfire, Capa, CF Series, CG_1, Chord, Circa, Clipper, Cobi, Collaboration, Convene, Coupe, Cura, Currency, dash, Divisio, Duo, E-Table 2, Edge Series, Elbrook, Elective Elements, Embold, Empath, Everwall, Exponents, Folio, FrameOne, Gesture, Groupwork, Host, Hosu, i2i, Jenny, Kart, Kathryn, Kick, Lagunitas, Leap, Leela, LessThanFive, LiveBack, LiveSeat, Mackinac, Marien152, Max-Stacker, media:scape, Migration, Millbrae, Mineral, Mitra, Montage, Montara650, MoreThanFive, Move, Node, Ocular, Ology, Opus, Paperflo, Passerelle, Player, Pocket, Potrero415, QiVi, Radia, Regard, Relay, Reply, Ripple, Roam, Sarto, Scoop, Sebastopol, Senti Series, Senza, Shortcut, Sidewalk, Siento, Sieste, SILQ, Soffio, Sorrel, SOTO, Steelcase Eclipse, Steelcase Flex, Steelcase Karman, Steelcase Relay, Steelcase Rise, Steelcase Series, Surround, SW_1, Switch, Sync, Tava, Tenor, Think, Thoughtful, Thread, Together, Train, Trees, Turnstone, Umami, Underscore, V.I.A., Verb, Verge, Verlay, Victor2, Visalia, WorkValet, and X-tenz.

™/® The following are trademarks or registered trademarks of AMQ Solutions, LLC: 3F, Activ, Amobi, Bixby, Bodi, Cluvo, Concur, Embank, FL-X, Iline, Jaku, Kinex, Personality Plus, Revi, S-Series, Siya, Tektis, Tizu, Uptake, and Zilo.

™/® The following are trademarks or registered trademarks of Orangebox Ltd., Cardiff, UK: Air3, Aspect, Avi, Away from the Desk, Border, Campers & Dens, Coppice, Cubb, Kirm, On the QT, Ramsey, Skomer, Sully, Track-B, and Vale.

™/® The following are trademarks or registered trademarks of Viccarbe Habitat, S.L.: Aleta, Cambio, Designed in The Sun, Foro, Funda, Holy Day, Kelly, Last Minute, Noha, Savina, Sistema, Sistema, Viable, and Wrapp.

® The following are registered brands of Steelcase Inc. and its family of companies: Steelcase, AMQ, Coalesse, Designtex, Halcon, Orangebox, Smith System, and Viccarbe.

® The following registered trademarks are under license from AWI Licensing Company, Dover, DE: SoundScapes, DuraBrite, BioBlock, and Armstrong.

® The following registered trademarks are under license from Byrne Electrical, Rockford, MI: Interport, Mini-Port, Axil Z, and Ellora.

® The following is a registered trademark of DuPont, Wilmington, DE: Corian.

® The following is a registered trademark of Genlyte Thomas Company, Louisville, KY: Lightolier.

® The following is a registered trademark of Hilti Corporation, FL-9494 Schaan, Principality of Liechtenstein: Hilti.

® The following is a registered trademark of Leviton Manufacturing Company, Little Neck, NY: Decora.

® The following is a registered trademark of Mechanical Plastics Corp, Elmsford, NY: Toggler.

® The following is a registered trademark of Microsoft Corporation, Redmond, WA: Microsoft.

® The following are registered trademarks of Orangebox Ltd., Cardiff, UK: Orangebox.

® The following is a registered trademark of Panduit Corporation, Lockport, IL: Panduit.

® The following is a registered trademark of Trav (Press), Cuneo, Italy: Assisa.

® The following is a registered trademark of Virtual Ink, Boston, MA: mimioActive.

® The following registered trademarks are under license from Wilkhahn Furniture Products: Avera, Senzo, Versal, and Wilkhahn FS.

® The following are registered trademarks of Polyvision Corp: Flow, Motif, Polyvision, Sans, and Serif.

® The following is a registered trademark of Wilsonart International, Temple, TX: Chemsurf.

® The following is a registered trademark of Wiremold, West Hartford, CT: Wiremold.

® The following is a registered trademark of EMU Group S.P.A., Perugia, Italy: EMU.

® The following is a registered trademark of Security People, Inc.: Digilock.

® The following are registered trademarks of Natural Capital Partners Europe Limited: CarbonNeutral and the CarbonNeutral Certified logo.

™ The following is a trademark of Microsoft Corporation, Redmond, WA: Windows.

™ The following is a trademark of Rodman Industries, Inc., Oconomowoc, WI: ResinCore1.

™ The following is a trademark of Ultrafabrics, LLC, Elmsford, NY: Ultraleather.

™ The following trademarks are under license from Wilkhahn Furniture products: Cana, Linus, Logon, Picto, Range, Stitz, Thema, Timetable, and Tubis.

™ The following trademarks are under license from Walter Knoll: Andoo, Bob, Lazlo, Lox, Ribbon, and Together.

™ The following trademarks are under license from PP Mobler: Bar and Flag Halyard.

™ The following trademarks are under license from Carl Hansen: Elbow, Paddle, Shell, Wing, and Wishbone.

™ The following trademarks are under license from Cambridge Sound Management, LLC Cambridge, MA: QtPro Soundmasking, Qt Quiet Technology, and Sonet Qt.

™ The following is a trademark of Electri-Cable Assemblies, Shelton, CT: Interact.

™ The following is a trademark of Clestra Hauserman: IRYS.

™ The following is a trademark of Wiesner-Hager Möbel GmbH: Nooi.

™ The following are trademarks of Polyvision: Accord, a3, e3, Boundri, and Nota.

™ The following is a trademark of Bostock Company, Inc: SnapCab.

™ The following is a trademark of Williams-Sonoma, Inc: West Elm.

™ The following is a trademark of Elena Marquina Testor: nanimarquina.

™ The following is a trademark of Forbo International SA: Forbo.

Trademarks used herein are the property of Steelcase Inc. or their respective owners.