

---

# AMQ

## Specification Guide

### Availability

**Electronic price list updated** with release 204.C (U.S.) and 158.C (Canada), dated June 15, 2026.

All specifications subject to change without notice. Reference the electronic catalog/Hedberg for current pricing.

Trademarks contained herein are the property of AMQ Solutions, LLC or their respective owner.

For ordering or product assistance, please call your local dealer, the Steelcase Solutions Resource Team, or the Steelcase Solutions Fulfillment Team at 1.888.STEELCASE (1.888.783.3522) or send an e-mail to [line-one@steelcase.com](mailto:line-one@steelcase.com).

---

<b>General</b>	<b>2</b>
----------------	----------

---

<b>Furniture</b>	<b>19</b>
------------------	-----------

<b>Seating</b>	<b>415</b>
----------------	------------

---

<b>Resources</b>	<b>505</b>
------------------	------------

<b>Furniture Finishes</b>	<b>506</b>
---------------------------	------------

<b>Seating Finishes</b>	<b>508</b>
-------------------------	------------

<b>Style Number Index</b>	<b>510</b>
---------------------------	------------



### For Canadian Pricing

Canadian factor can be found at [www.steelcase.com/CADpricing](http://www.steelcase.com/CADpricing). Calculate in the following order to avoid rounding errors:

- Multiply the base price and each option by the Canadian factor.
- Round each to the nearest dollar.
- Add base and options for total list price.

# Orders

## Orders

Please send P.O.s to [orders@amqsolutions.com](mailto:orders@amqsolutions.com).

## Cancellations

Orders may be cancelled within 48 hours of order placement in writing via email to [orders@amqsolutions.com](mailto:orders@amqsolutions.com). Please note that orders are not officially cancelled until a confirmation is sent via email from AMQ. Custom or made-to-order products are not eligible for cancellation.

## Returns and Exchanges

We do not accept returns or exchanges on products; sales are final once acknowledgments are sent. If a product is ordered by mistake or other issue arises, contact us at [orders@amqsolutions.com](mailto:orders@amqsolutions.com).

## Change Orders

Orders may be changed within 48 hours of order placement. The request must be made via email to [orders@amqsolutions.com](mailto:orders@amqsolutions.com). The change order is subject to approval and is not accepted until an AMQ acknowledgment is sent to the dealer. In the event that a change order is accepted, change fees may apply. Lead time starts on the day of approval of changes.

## Pricing/Order Entry Errors

Claims for pricing or order entry errors must be made no later than 48 hours from receipt of an AMQ acknowledgment. After the 48 hour grace period, customers will be responsible for orders as they are acknowledged.

Please send emails to [orders@amqsolutions.com](mailto:orders@amqsolutions.com) along with your order acknowledgment number, line number with error and detail of the error.

## Lead Times

Lead times vary by product - refer to our Lead Time table. Lead time begins the day after receipt of a clean P.O., including receipt of deposit if applicable. When your order is shipped, a tracking notification will be emailed to the contact specified on your purchase order.

## Order Fulfillment

We make every attempt to ship all of our orders complete. In the event of a partial or split shipment, you will be notified and an estimated date will be provided for the backordered items. We cannot guarantee which warehouse the product will ship from.

Customer has 10 calendar days after delivery at the specified location to file a claim with AMQ for missing items or AMQ errors not obvious at the time of delivery. If AMQ determines missing items or error was made by AMQ, AMQ's sole obligation is to replace the missing items or correct error and ship at AMQ's expense. AMQ does not cover labor or trip charges. Customer waives right to file a claim if filed after 10 calendar days of receipt of shipment.

# Warranties

Product warranties vary; refer to the Warranty sheet in Dealer Tools.

AMQ's obligation under this warranty is limited to replacing any product or part that it determines to be defective after inspection by its authorized representative, following receipt of written notice of the defect from the purchaser within the warranty period. This warranty shall apply to the original purchaser only, is non-transferable, and is not applicable outside the United States, Canada, and Mexico.

This warranty is based on normal installation and use of the product in an 8-hour shift. This warranty does not apply to:

- Damage in shipment caused by a carrier
- Defects caused by improper installation
- Products subject to improper use and conditions
- Customer modifications to the product
- Any product that has been modified, altered, tampered with or repaired by any person other than an authorized representative of AMQ
- Normal wear and tear

Labor charges and/or damage incurred in the installation, repair, or replacement of any products are excluded; AMQ will replace the product if the claim is approved.

## Product Design

The right is reserved by AMQ to make changes in design and material, as well as discontinuance of parts and units when such action is deemed to be an improvement in design, function and/or construction.

## Warranty Claims

Please email claims to [cc@amqsolutions.com](mailto:cc@amqsolutions.com).

Lead Time	Product	Order Size
10 Day <sup>1</sup>	3F	25 workstations
	Seating	
	Activ	
	Kinex	
	Iline	
	Accessories	
	Storage	
	Concur	
	Intro Worktools	
	Majority of Tektis	
	Majority of Embank	
20 Day	Select Styles of Embank • 3- and 4-High Laterals • Credenzas w/ Kneespace • D- and P-Shape Desks Tables • Dual Towers • Modesty Panel • Conference & Collaborative Tables	26-50 workstations
	Tektis Corner Worksurfaces	
	25 Day	
West Elm Work Brighton		

<sup>1</sup>The default lead time is 12 days when 10 days is not requested.  
<sup>2</sup>Larger orders may extend past 25 days depending on inventory availability.

# Shipping

## Will Call

AMQ offers Will Call upon request; please contact [orders@amqsolutions.com](mailto:orders@amqsolutions.com) for details.

## Freight Terms

Freight is included in pricing for all \$1500+ Net Orders, and Seating- or Accessories-only Orders regardless of Net, shipped within the 48 contiguous United States. For orders under \$1500 Net, a \$100 surcharge is added.

All shipments within the 48 contiguous United States, except those designated ports of disembarkation, will be shipped FCA Factory, freight prepaid and allowed regardless of weight. AMQ may select the most appropriate mode of shipment from the manufacturing point of its choice. Special shipping methods and/or handling (including customer requested split shipments) will be subject to an additional charge. Any special freight requirements must be requested prior to order placement and are subject to approval by AMQ. Please contact AMQ Customer Care team for details.

## Freight – Canada/Hawaii/Alaska

For shipments to Canada, AMQ pricing only includes Transportation fees (dock to dock). Any other fees or costs associated with shipment, such as customs clearance and import duty/taxes shall be paid directly by the Customer. For shipments to Hawaii/Alaska, AMQ pricing does not include freight. Customer will be responsible for arranging and paying all shipping costs.

## Commitment Delivery Option

AMQ offers 12 day delivery on 97% of our portfolio, when requested. Delivery times are at the discretion of the carrier within reasonable transit time unless special arrangements have been agreed to in writing between the Customer and AMQ prior to shipment. There is an additional charge to guarantee delivery on a specific day. These charges will be quoted at Customer request.

## Redelivery and Re-consignment of Freight

The Customer will be charged for redelivery or re-consignment of all orders (regardless of shipping terms agreed to) if redelivery or re-consignment was caused by a Customer change after the goods have left AMQ's dock.

## Shipment Damage Claims

All shipments must be carefully inspected by Customer before acceptance. The Customer must record any damage or shortages noted at time of delivery on the Bill of Lading, and provide this information to AMQ immediately along with photos of any damage. AMQ will arrange inspection by the carrier. If Customer believes it has uncovered further damage after delivery they must take photos of the damage and immediately request inspection by the delivering carrier. Damaged freight must be kept at point of delivery in original packaging for inspection by carrier until further notice by AMQ. If carrier is designated by AMQ, then AMQ will seek recourse on behalf of the Customer. Freight Claims must be filed within 10 days of delivery date.

AMQ warrants to the original purchaser that the products it manufactures are free from defects in design, material and workmanship. Subject to the limitations below, AMQ warrants each product in this catalog to be free from material defects in materials and workmanship.

## Title

Title and risk of loss or damage shall pass from AMQ to Customer/Dealer upon delivery to the carrier, including Steelcase trucks.

## Submission of Claims

Please submit all order fulfillment, shipping, and warranty claims to [cc@amqsolutions.com](mailto:cc@amqsolutions.com).

## Order Processing

Please send purchase orders to [orders@amqsolutions.com](mailto:orders@amqsolutions.com).

- Lead times start from the next day after receipt of clean P.O.
- P.O.s with missing information/finishes or incorrect pricing will be placed on order processing hold and the lead time will not start until the revised P.O. is sent to Customer Care ([orders@amqsolutions.com](mailto:orders@amqsolutions.com)).
- Please provide .sif file and AMQ quote number along with P.O., if applicable.
- Orders will be acknowledged within 24-48 hours with an AMQ acknowledgment number.
- Claims for quote errors, pricing, order entry errors and/or incorrect finishes must be made within 48 hours of receipt of acknowledgment. After 48 hours, AMQ will not be responsible for errors.
- P.O.s must include your Joey Coin # in order to obtain Joey points. Register at [amqsolutions.com/joey](http://amqsolutions.com/joey) and within 5 business days you'll receive your Joey Coin #.

**Please be sure to check order acknowledgments to confirm accuracy of products, fabrics and finishes against your purchase order.**

## Payments & Deposits

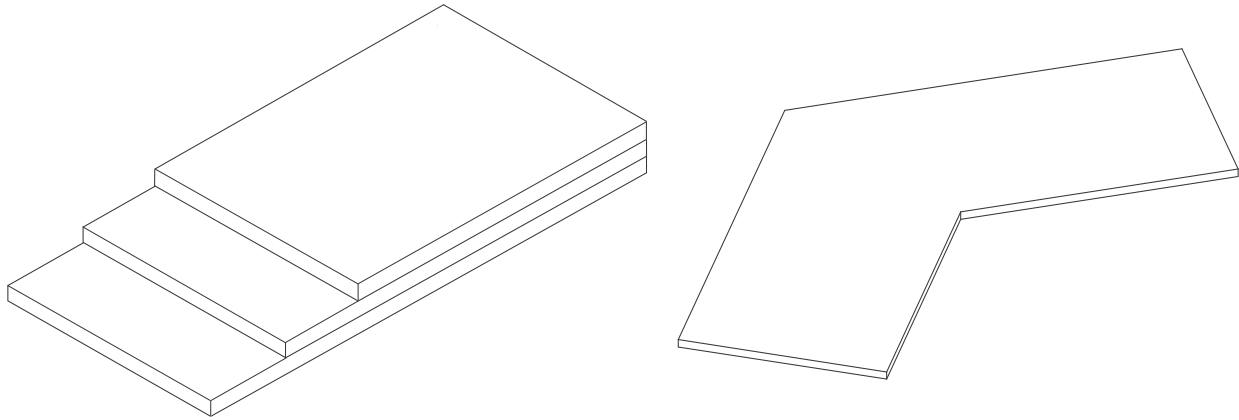
Terms of payment will be established based on the credit rating and credit information provided by and for specific customers. Orders are invoiced at the time of shipment or will call date. Standard payment terms are net 30 days.

	Orders Under 40,000 Net	Orders Over 40,000 Net
Deposit	No Deposit Required*	50% Deposit Due Upon Order
Balance Due	Net 30	Net 30

\*First order with new dealership requires 50% deposit.



# Worksurfaces



**AMQ worksurfaces are low pressure laminate (LPL).**

Available in linear, 90° and 120° degree shapes in thirteen colors: Acacia, Arctic White, Ash Wenge, Clay Noce, Clay Wenge, Clear Maple, Clear Oak, Clear Walnut, Graphite Walnut, Milk White, Natural Cherry, Seagull, and Virginia Walnut.

---

## Specifications

---

LPL (low pressure laminate)

---

1 inch/25mm thick

---

3mm PVC on four sides

---

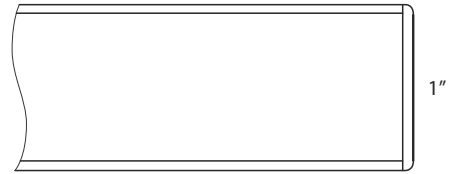
Linear, 120, extended corner

---

Our linear worksurfaces come in 48", 54", 60", 66" and 72" widths at 23", 24", 29", or 30" depths. Plus 46", 52", 58", 64" & 70" widths at 23", 24", 29", or 30" depths.



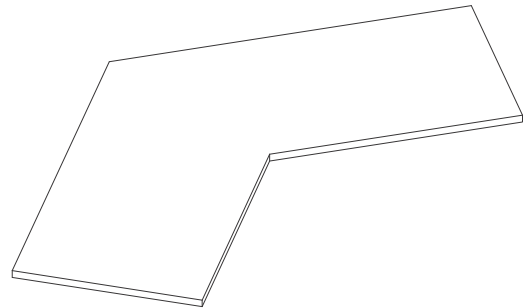
72" width



Worksurfaces are 1" thick with 3mm PVC on 4 sides.



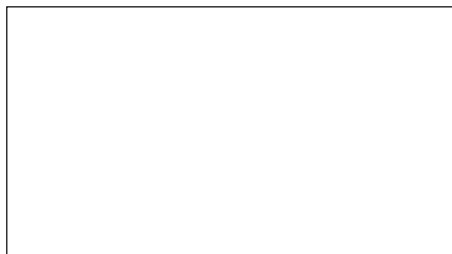
66" width



120° worksurfaces also available for ACTIV height adjustable base.



60" width



54" width

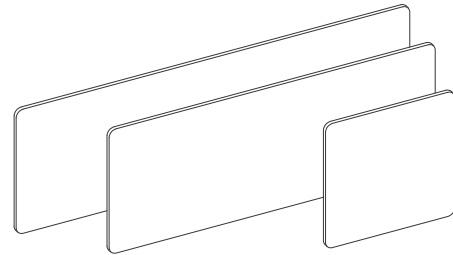
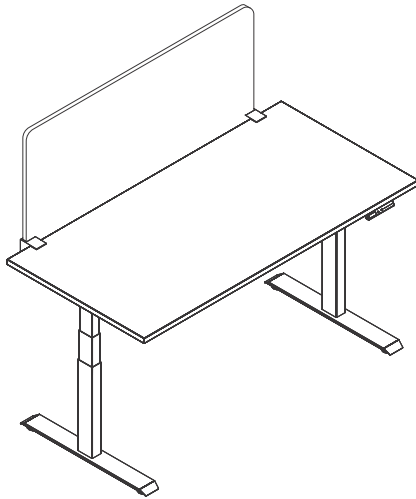


48" width

# Privacy Screens

We offer 3F privacy screens for your open plan environments.

3F Felt Screens offer 5 attachment options with varying functionalities



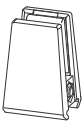
## 3F Screens

AMQ 3F felt screens are 18mm thick made from 100% Polyester.

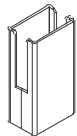
Oeko-Tex Standard 100

## Screen Clips and Brackets

AMQ screen clips vary by product line and configuration. All sold in pairs (separately from screens). Activ base clips work with worksurfaces between .7"-1.5" (18mm and 40mm) thickness.



Iline



Kinex double run



Top Mounted Bracket



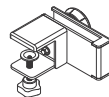
Top Mounted Bracket Clamp



Undermounted Sleeve Bracket



Fixed Privacy Modesty Bracket



Height Adjustable Bracket

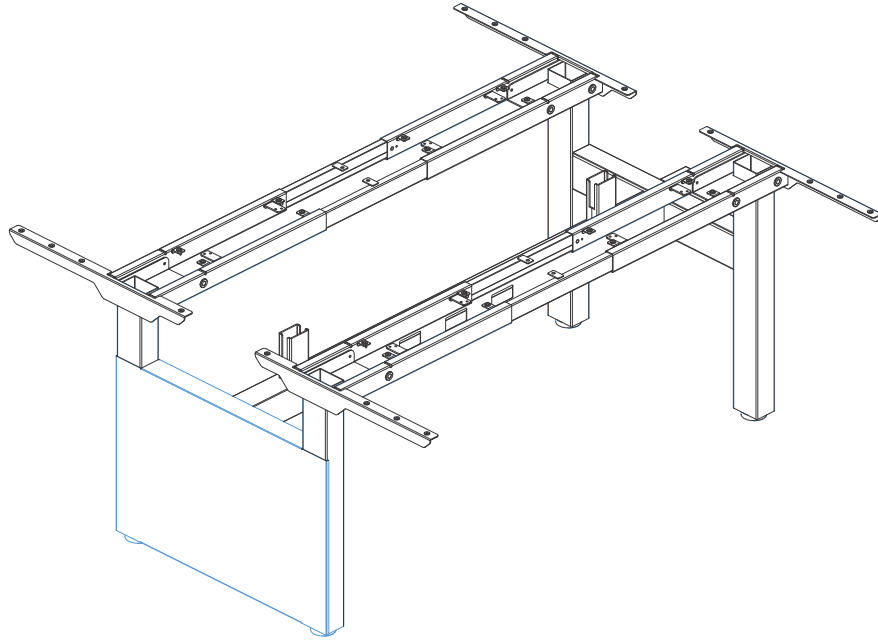


Screen Corner Connector

3F Screens



## Modesty & Insert Panels



---

**Kinex End Panel**

End Panel for 24" and 30" DR applications.  
Available in Platinum and White.

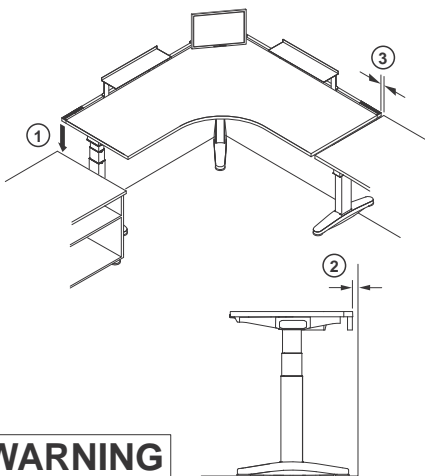
# Workstation Design Guidelines & Requirements

## Overview

Designed for movement with dynamic seating, adjustable work tools and height-adjustable desks are important for today's office workers.

To determine the best height-adjustable solution, consider these four criteria:

1. Adjustability needed: What is the height range requirement? (seated or sit-to-stand)
2. Worksurface size needed: What does the physical space look like? (worksurface configuration)
3. Equipment/tools used: What type of computer equipment and other work tools are being used on the worksurface? (Load capacity)
4. Use: What is the height adjustable desk being used for (individual or shared, touchdown space or full workstation, sit-to-stand or seated)?



### ⚠ WARNING

Risk of Serious Injury. If not used as intended, moving work-surfaces can pinch or injure people, or damage property. Always follow these Instructions:

1. Keep height-adjustment range free from obstructions above and below the worksurface.
2. Plan for a minimum 1" gap against a panel or wall.
3. Plan for a minimum 1" gap to adjacent furniture.

## Tips

### Obstructions

Moving worksurfaces can collide with other objects. Do not install overhead storage, stationary pedestals or components in the path of height-adjustable desks.

### Weight

The maximum allowable load (varies by height-adjustable desk) should be evenly distributed and must not be exceeded.

### Width

Specify a minimum 1" gap to adjacent furniture. This eliminates any pinch points between a height-adjustable desk and a fixed object.

### Depth

When placing a height-adjustable desk against a panel or wall specify the worksurface depth shorter to provide a minimum 1" gap. This eliminates pinch points and adds clearances for cable access.

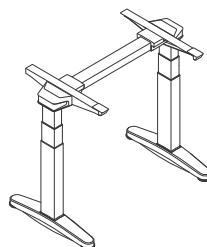
### Managing Technology

Design workstations with computer equipment in mind so that the height-adjustment range of the height-adjustable desk is not impeded because of cables. Consider the addition of a cable riser, cable basket, or cableway to help harness these wires and cables.

### Power

Plan easy and unobstructed access to electrical outlets for computer equipment and height-adjustable desks (when applicable).

AMQ Specification Guide



### ⚠ WARNING

Risk of serious injury.

Bases-only warranty limitations and potential for injury: The use of worksurfaces that do not comply with the AMQ defined criteria and limitations could cause personal injury or property damage due to pinch points, instability, or other problems, and voids all AMQ Warranties, expressed or implied.

The use of worksurfaces that do not comply with AMQ criteria voids any AMQ claims of compliance with ANSI/BIFMA, UL, LEED, or other applicable requirements. The use of non-AMQ worksurfaces on AMQ height adjustable bases may not be accepted as compliant to municipal electrical codes or OSHA federal workplace standards, because this use does not create an NRTL (UL, ETL, etc.) listed product. AMQ is not responsible for the ultimate determinations of compliance for height-adjustable bases with non-AMQ worksurface, and assumes no liability for their compliance with standards when height adjustable bases are used without a AMQ worksurface as intended.

### Worksurface Criteria and Limitations

The use of non-AMQ worksurfaces is not recommended. Any use of a non-AMQ worksurface requires additional investigation by the customer regarding the appropriateness for use. It is the sole responsibility of the customer to determine the suitability and safety of the selected worksurface construction and attachment means. The following information is provided as a guideline, but does not address all potential issues. Customers should seek professional guidance as to the appropriateness of their chosen worksurface.

## Tips

- Height-adjustable bases include fasteners intended for use with AMQ worksurfaces. These fasteners may be suitable for worksurfaces meeting the following criteria: Medium-density or higher particleboard or berboard cores, with High- or Low-Pressure Laminates and backers.
- Thickness of 1" or greater.
- Fasteners located a minimum distance of 1" from any edge.

## Electrical — General

---

We use the USA-based company Byrne Electrical for all our power and data.

The Byrne 8-Trac System and Phase 3 are UL recognized as an Office Furnishing Accessory (UL 1286), and are UL Listed as a Manufactured Wiring System (UL 183) in full compliance with electrical specifications found in the National Electrical Code (NEC). It also complies with municipal standards such as New York, Los Angeles and San Francisco.

To learn more about Byrne, visit their website at [www.byrne-electrical.com](http://www.byrne-electrical.com)



# Electrical — 3 Circuit/5 Wire

The Byrne Phase 3 System is similar to 8-trac system except is a double sided 3-Circuit/5-Wire system. It Includes flexible mesh conduit jumpers (UL1286 only). Also offers multiple circuit configurations selected by the receptacles.

---

## Specifications

---

UL183 Listed and UL 1286 Recognized in full compliance with National Electric Code (NEC)

---

3-Phase System

---

Modular Receptacles

---

Flexible mesh conduit jumpers (UL1286 only)

---

Multiple Circuit configurations selected by receptacles

---

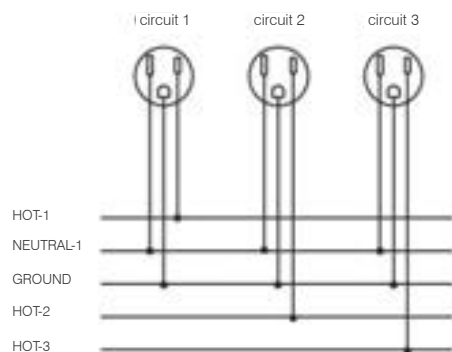
Double-sided system

---



---

## Wire Diagram for 3 Keying



# Electrical — 4 Circuit/8 Wire

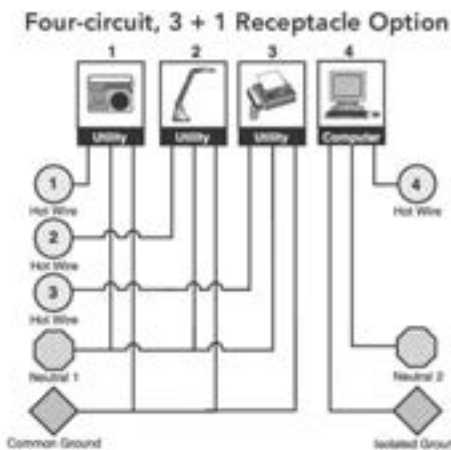
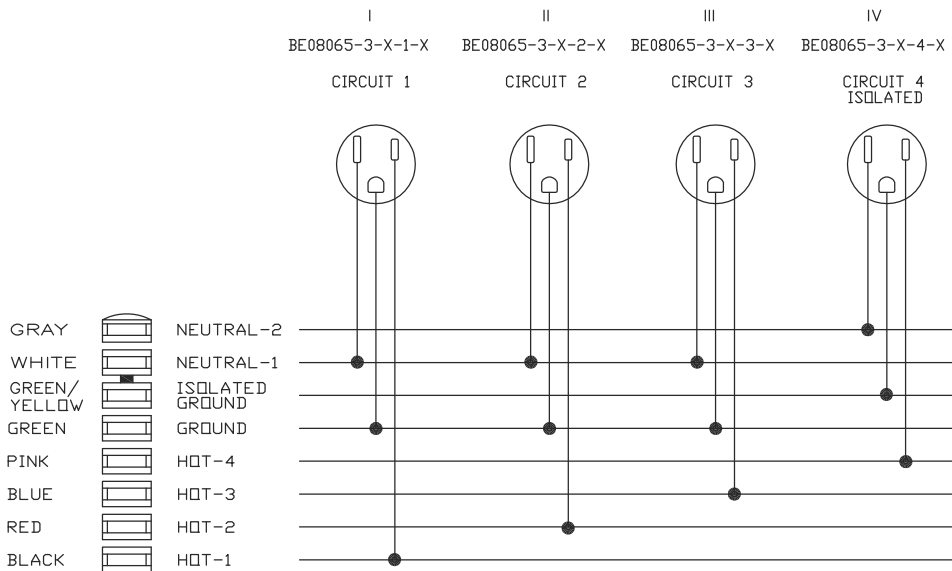
## BYRNE 8-TRAC SYSTEM

The Byrne 8-Trac System is rated for 15 amps allowing the use of 4 circuits with 4 line conductors, 2 neutrals and 2 grounds. Under NEC requirements, up to 13 duplex receptacles maybe used per circuit, with a total of 52 available receptacles if all circuits are used, per single power entry. The line conductors are 12 AWG, and share 12 AWG ground and a 10 AWG neutral. The fourth circuit is isolated and dedicated, and is serviced by its own line conductor, neutral and isolated ground. The Byrne System can be wired in both single and 3-phase configurations, 240/120V, 208/120V respectively. Additionally, a 3 hot, 3 general, 2 ground (3-3-2) wiring system is available.

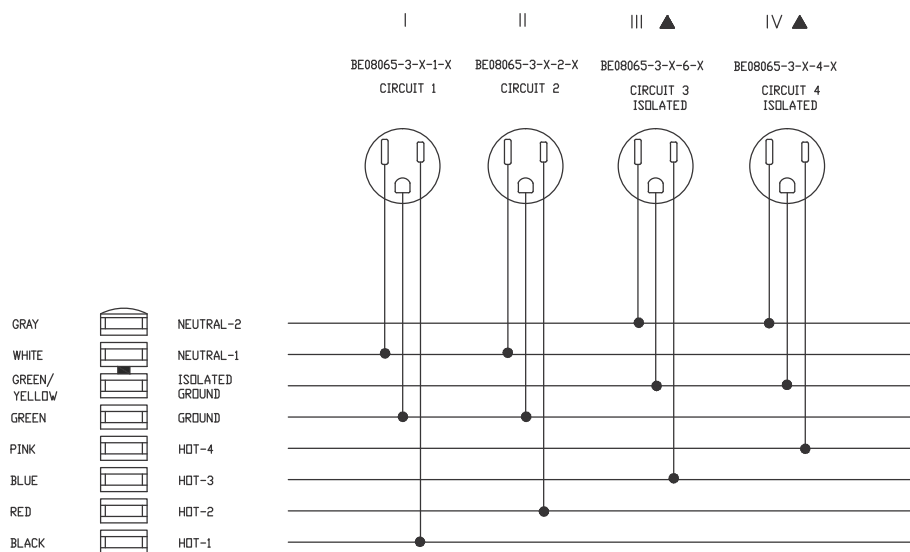
The System accommodates panel applications of 2" to 3½" thick harnesses available from 12" to 1800" in length.

Assemblies are 100% electrically tested to ensure the highest quality and reliability.

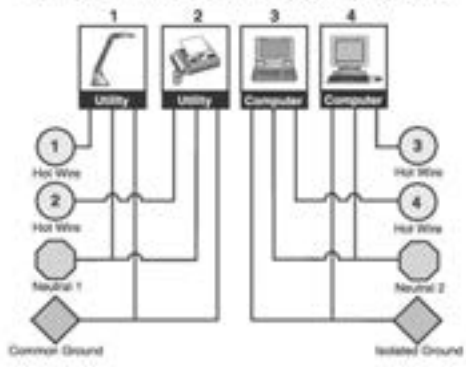
### 3+1



2+2 special order



Four-circuit, 2 + 2 Receptacle Option



## General — Unique Electrical Codes

The primary electrical code used in the United States is the National Electrical Code (NEC) (NFPA70). While most states and cities use the NEC as is, some have created their own electrical code using the NEC as the basis for the requirements. There are 3 cities that have unique requirements that directly affect office furnishings installations:

New York, Chicago, and San Francisco. These unique requirements are detailed below.

---

### Chicago

Chicago has their own electrical code based on the NEC.

Chicago does not allow the use of any modular systems. All electrical must be hardwired by a licensed electrician.

The specific wording of the 2009 Chicago Electrical Code is as follows:

**18-27-605.2. General.** Wiring in and on office partitions shall conform to all applicable chapter provisions. Relocatable wired partitions are not considered portable and, as such, plug and jack connections are not acceptable. All wiring is to be contained in listed and labeled electrical raceways and outlet boxes.

(a) Use. Wired relocatable office partitions shall be installed and used only as provided for by this Article. The biggest ambiguity is what product types will require TR receptacle for code compliance applications. For example, the NEC TR code dwelling requirements specify "appliances" as exempt from the scope of TR receptacles. Relocatable Power Taps are often grouped into this category.

Hardwire accessories can be used in Chicago if they have a metallic enclosure. This includes Mho, Assemble, Axil, Glenbeigh, and Wonderbar product lines. These hardwire units can be provided as a Chicago version which includes 15" of conduit and a 4X4 junction box.

---

## New York City

- Allows the use of Office Furnishings Systems (as permitted by Article 605 of the NEC) but requires that licensed electricians install the electrical components into the furniture.
- Does not allow the use of any non-metallic liquid tight conduit.
- Metallic liquid tight conduit can only be 18" long.
- Flexible metal conduit used on infeeds can only be 6' long.
- Does not allow Manufactured Wiring Systems in furniture.

As of 2009, New York City allows the use of Relocatable Power Taps in office environments.

The New York Electric Code exception of Article 604 for Manufactured Wiring Systems includes Article 604(3) Such wiring may only be used for general lighting circuits above the hung ceiling line.

Until now, this statement was interpreted as lighting circuits must be above the ceiling, while other Manufactured Wiring Systems can be used below the ceiling line.

The new official interpretation requested by BIFMA indicates Manufactured Wiring Systems can only be used for lighting and must be above the ceiling. This applies to Byrne 8-Trac, Byrne 4-Trac and Byrne Phase 3 product lines. This interpretation has not been published on the official NYC Codes site even though more recent interpretations have been. BIFMA continues to work on a resolution to this issue.

---

## San Francisco

San Francisco uses the California Electrical Code which in turn uses the NEC. San Francisco has additional / revised requirements that are called out as an addendum to the code. San Francisco does not allow the use of non-metallic liquid tight conduit and only metallic liquid tight conduit is permitted.

### ARTICLE 356 – LIQUIDTIGHT FLEXIBLE NONMETALLIC CONDUIT: TYPE LFNC

- 356.10      Revise the first sentence of this section as follows:  
 356.10      Uses Permitted.

LFNC shall be permitted to be used in exposed or concealed locations for systems not exceeding 50 volts for the following purposes:

356.12 Uses Not Permitted

356.12 Revise item 4 of this section as follows:

- (4) Where the operating voltage of the contained conductors is in excess of 50 volts, nominal, except as permitted in 600.32(A).



---

# AMQ Furniture

<b>KINEX</b>	<b>21</b>
<b>ILINE</b>	<b>35</b>
<b>Power &amp; Data</b>	<b>49</b>
<b>ACTIV PRO 2.0</b>	<b>57</b>
<b>CLUVO</b>	<b>79</b>
<b>CONCUR</b>	<b>89</b>
<b>3F</b>	<b>97</b>
<b>REVI</b>	<b>121</b>
<b>S-SERIES</b>	<b>129</b>
<b>Work Tools</b>	<b>139</b>
<b>TEKTIS</b>	<b>175</b>
<b>EMBANK</b>	<b>289</b>
<b>UPTAKE Lockers</b>	<b>383</b>
<b>West Elm Furniture</b>	<b>405</b>



---

# KINEX

**Understanding**

**22**

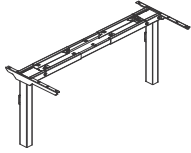
**Specifying**

**30**

KINEX

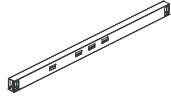
# Statement of Line

## Bases



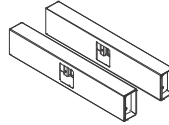
1 Stage/Fixed,  
2 Stage/dual motor,  
3 Stage/dual motor

## Beams



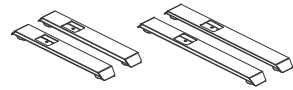
48", 54, 60", 66 and 72"  
*single and double run*

## Crossbeams



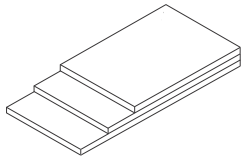
24" and 30"D

## Feet



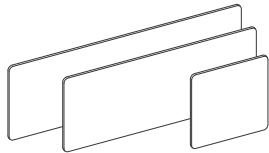
22" and 28" feet  
*single run applications only*

## Worksurfaces

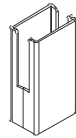


Linear

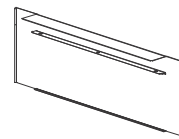
## Privacy Screens & Panels



3F Screens

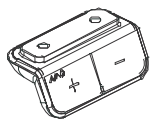


Screen Mounting Clip

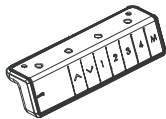


End Panel

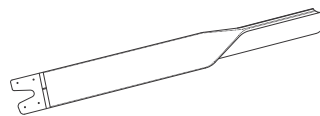
## Accessories



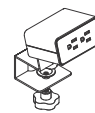
Standard Hand Set



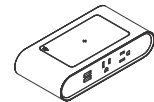
Pre-set Hand Set  
Upgrade



Soft Cable Management



Eco Power Box

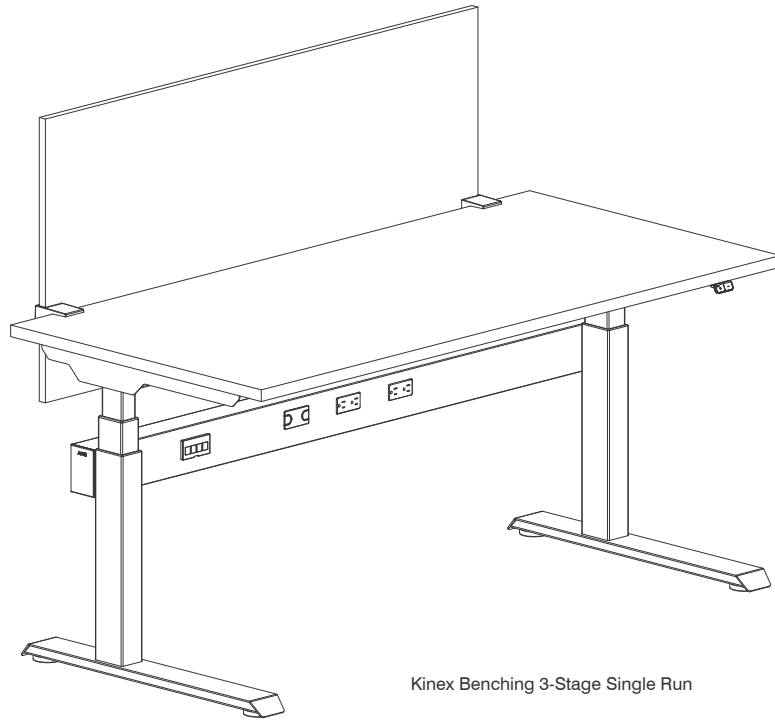


Boost Power Box

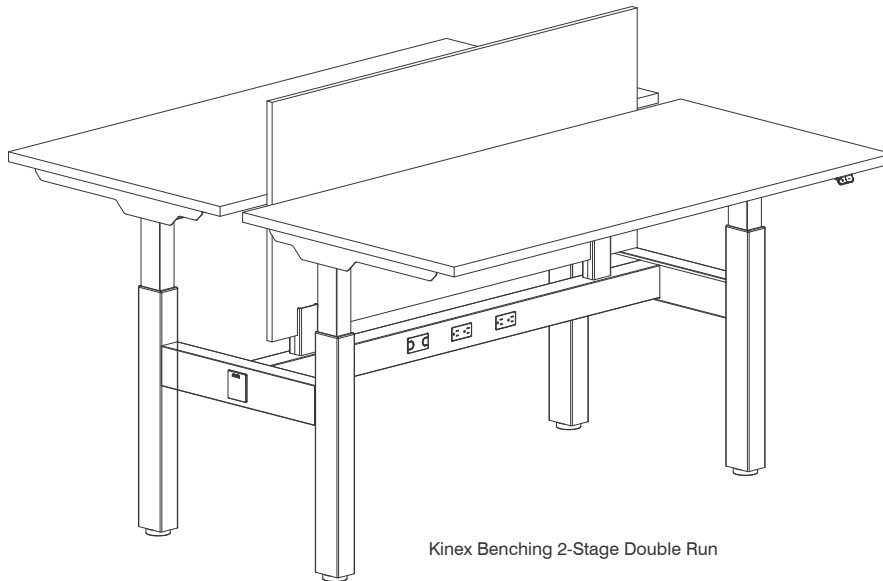


# Typical Configurations

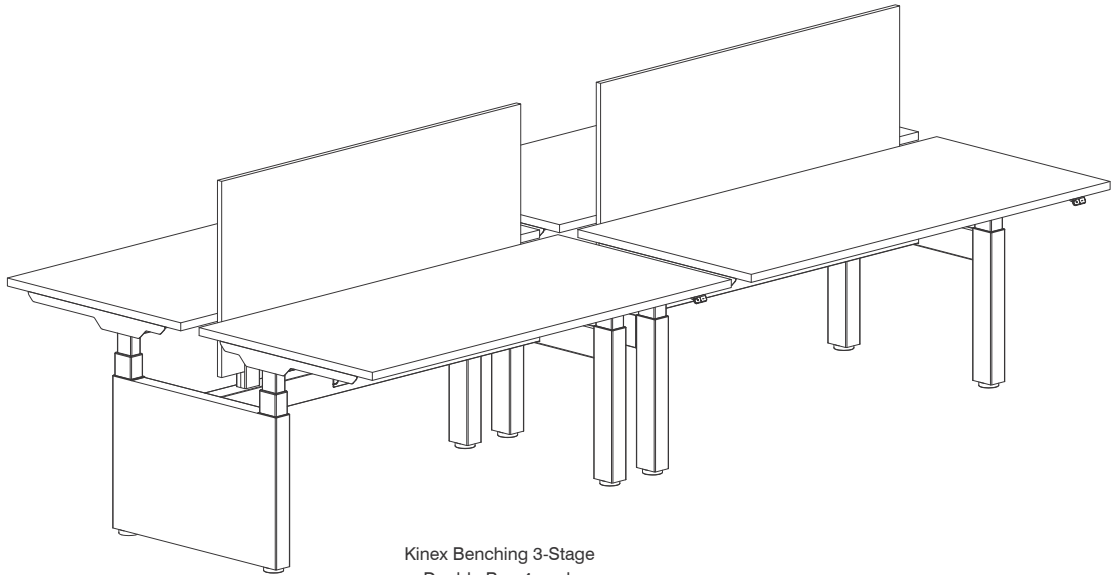
A full gallery of typicals is available on our web site.  
Each typical includes CET file, specifications, rendering and 2D layout.



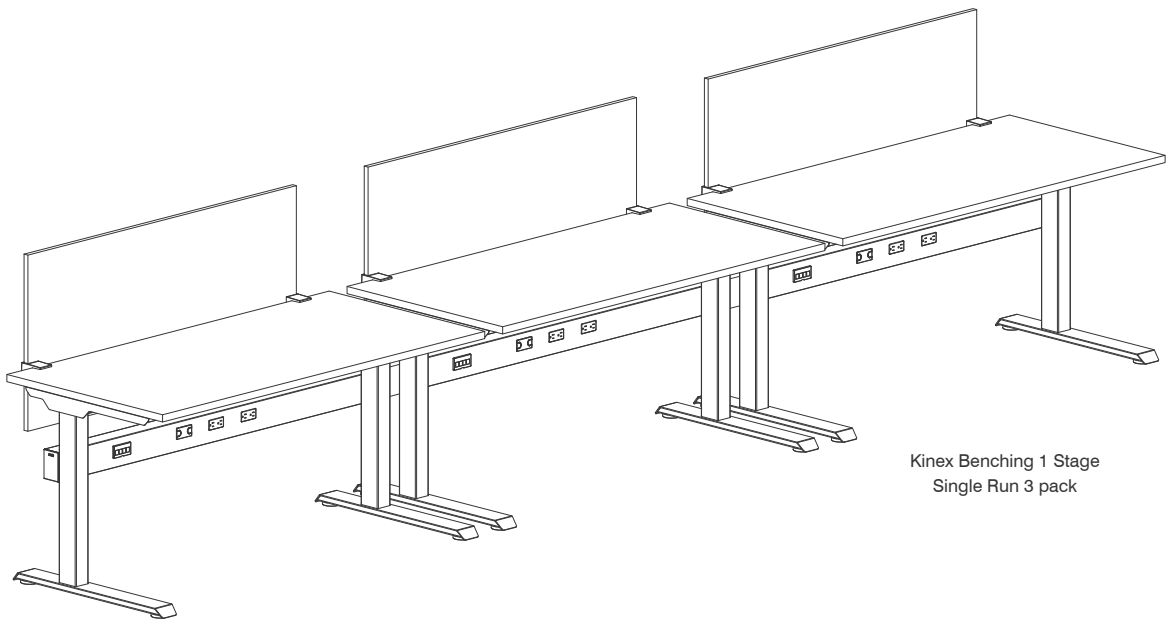
Kinex Benching 3-Stage Single Run



Kinex Benching 2-Stage Double Run



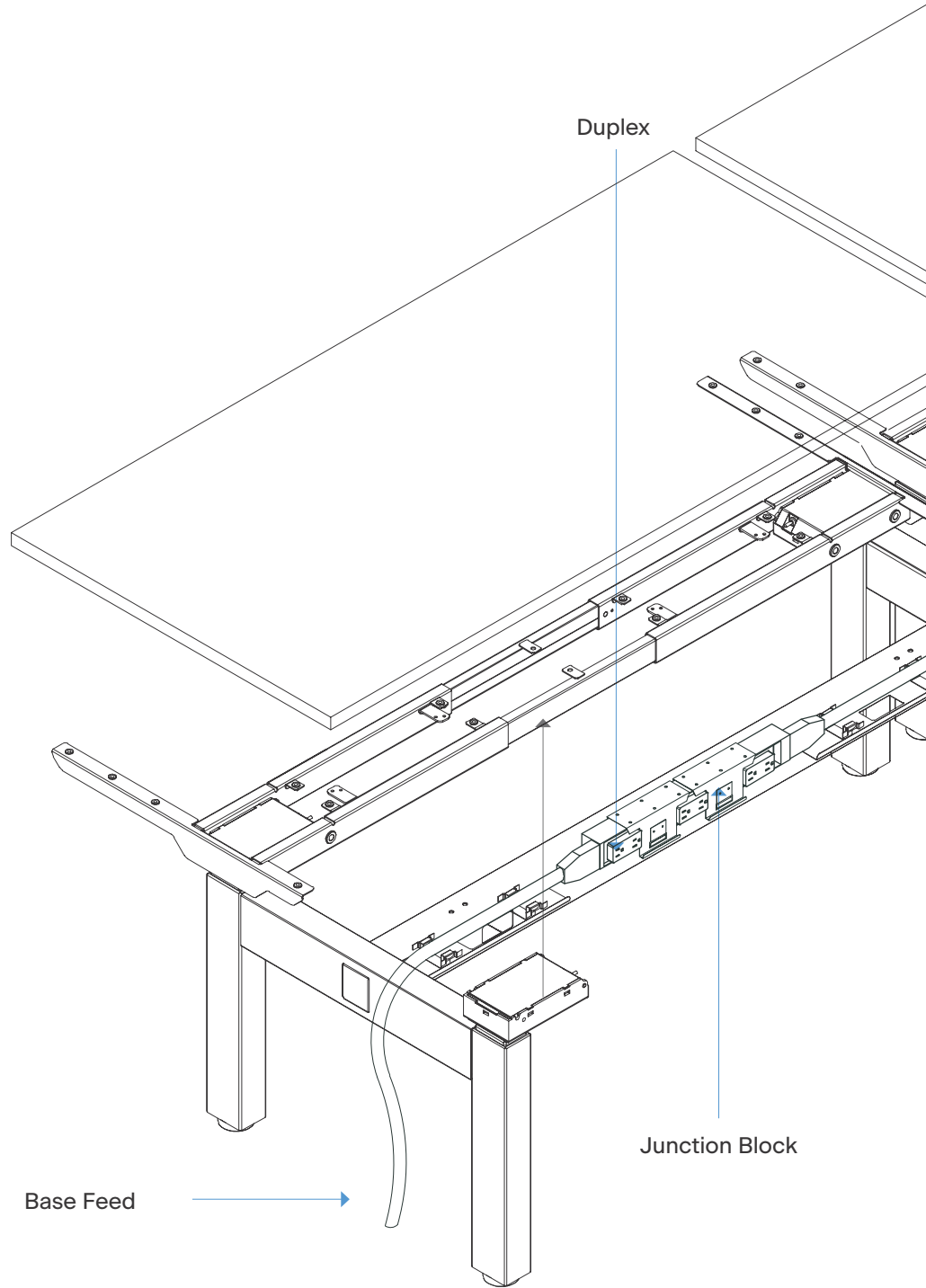
Kinex Benching 3-Stage  
Double Run 4 pack  
with end panel

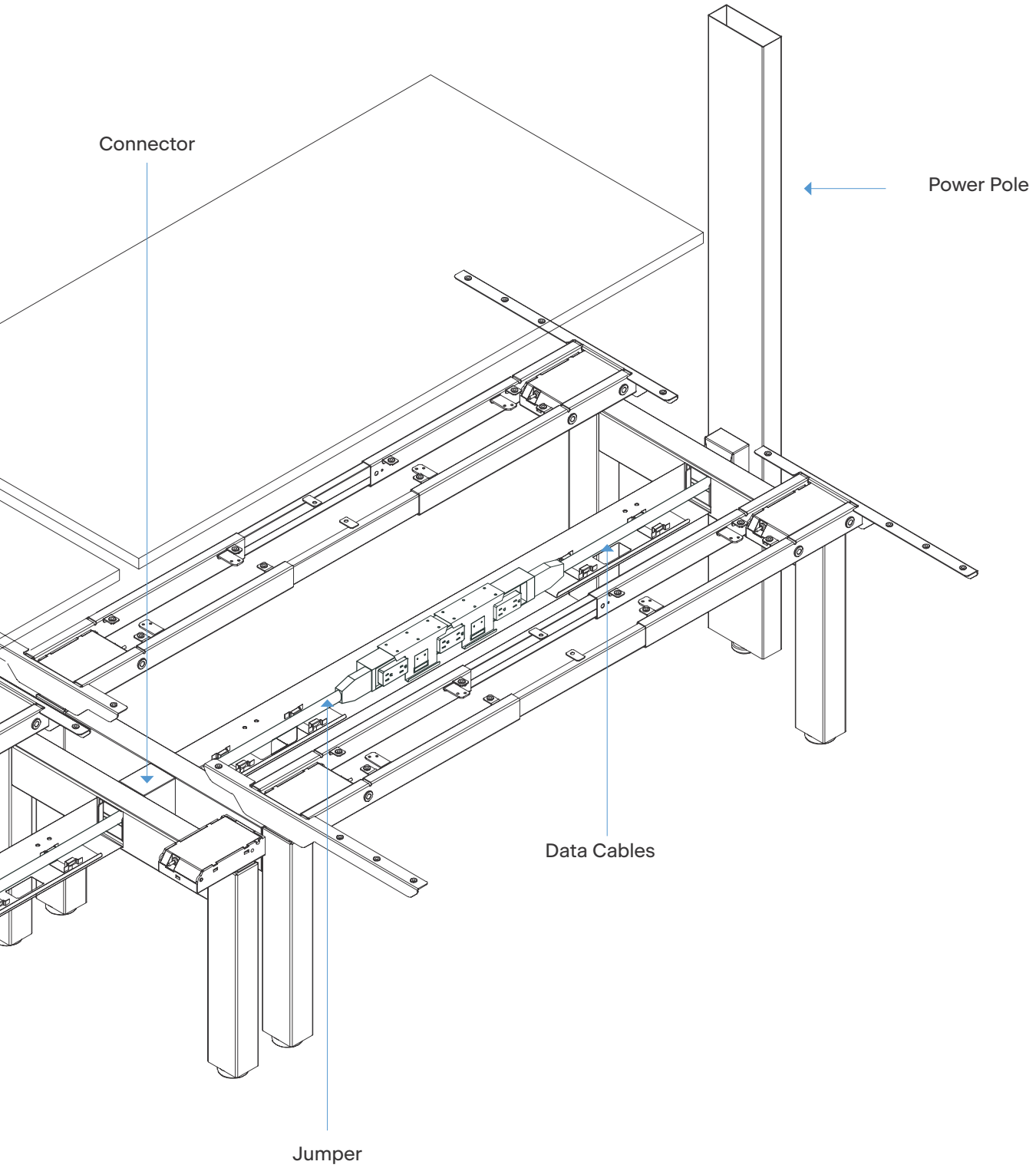


Kinex Benching 1 Stage  
Single Run 3 pack

# Electrical

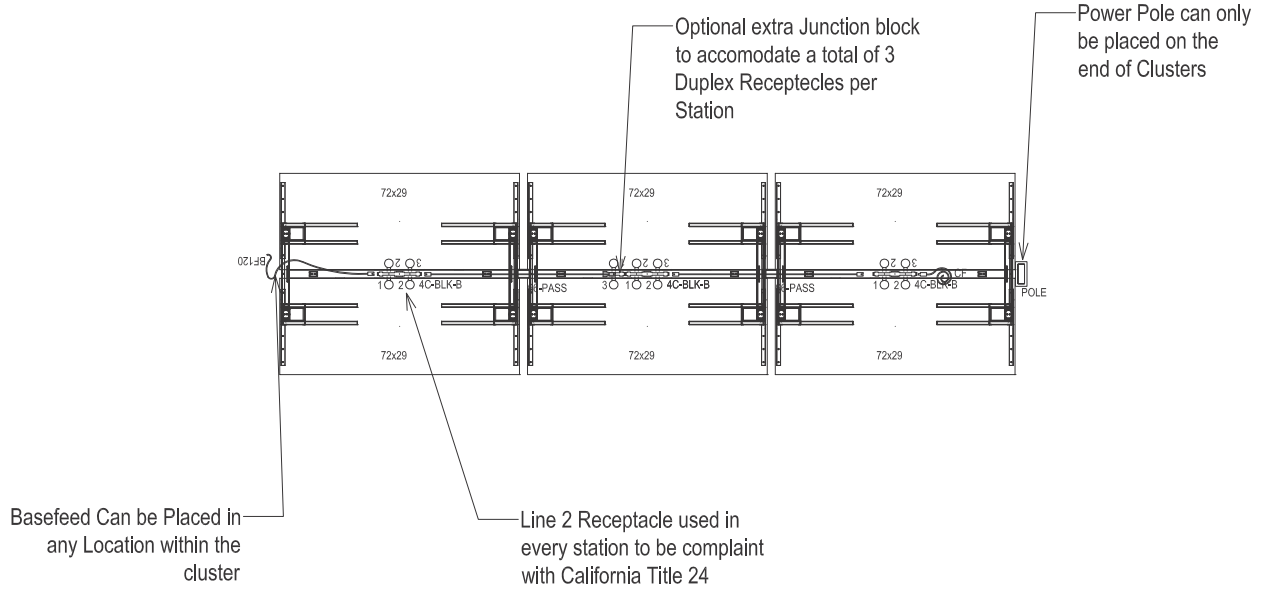
Kinex Benching uses Iline beam technology to distribute power, with either 3 circuit/5 wire or 4 circuit/8 wire electrical.



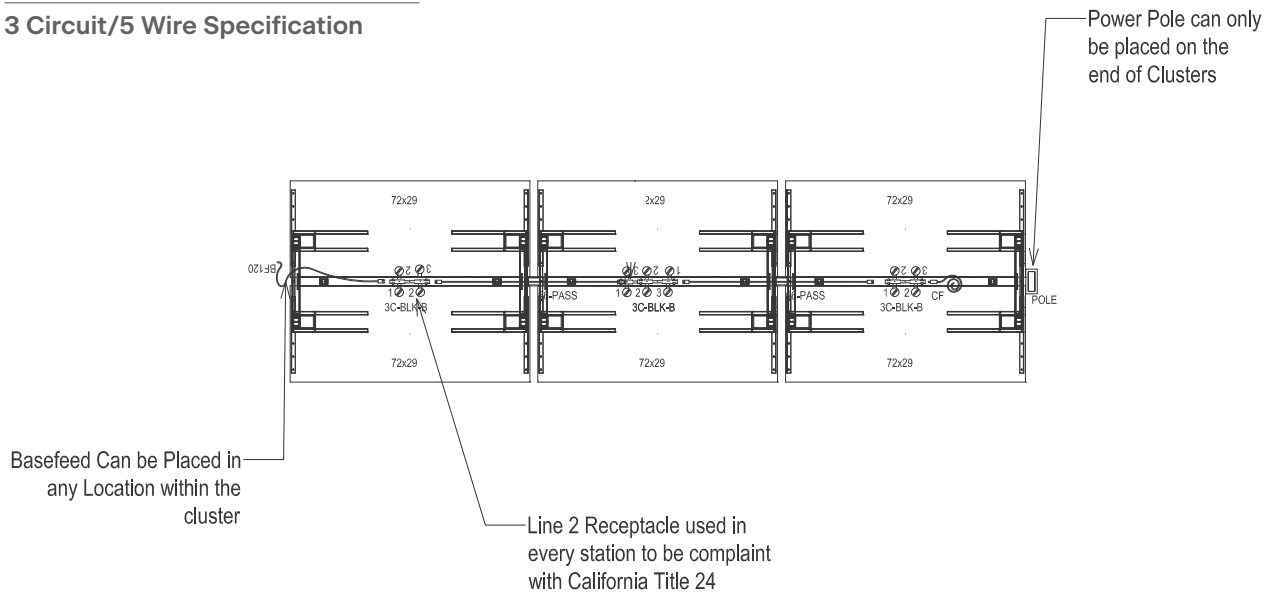


# Electrical

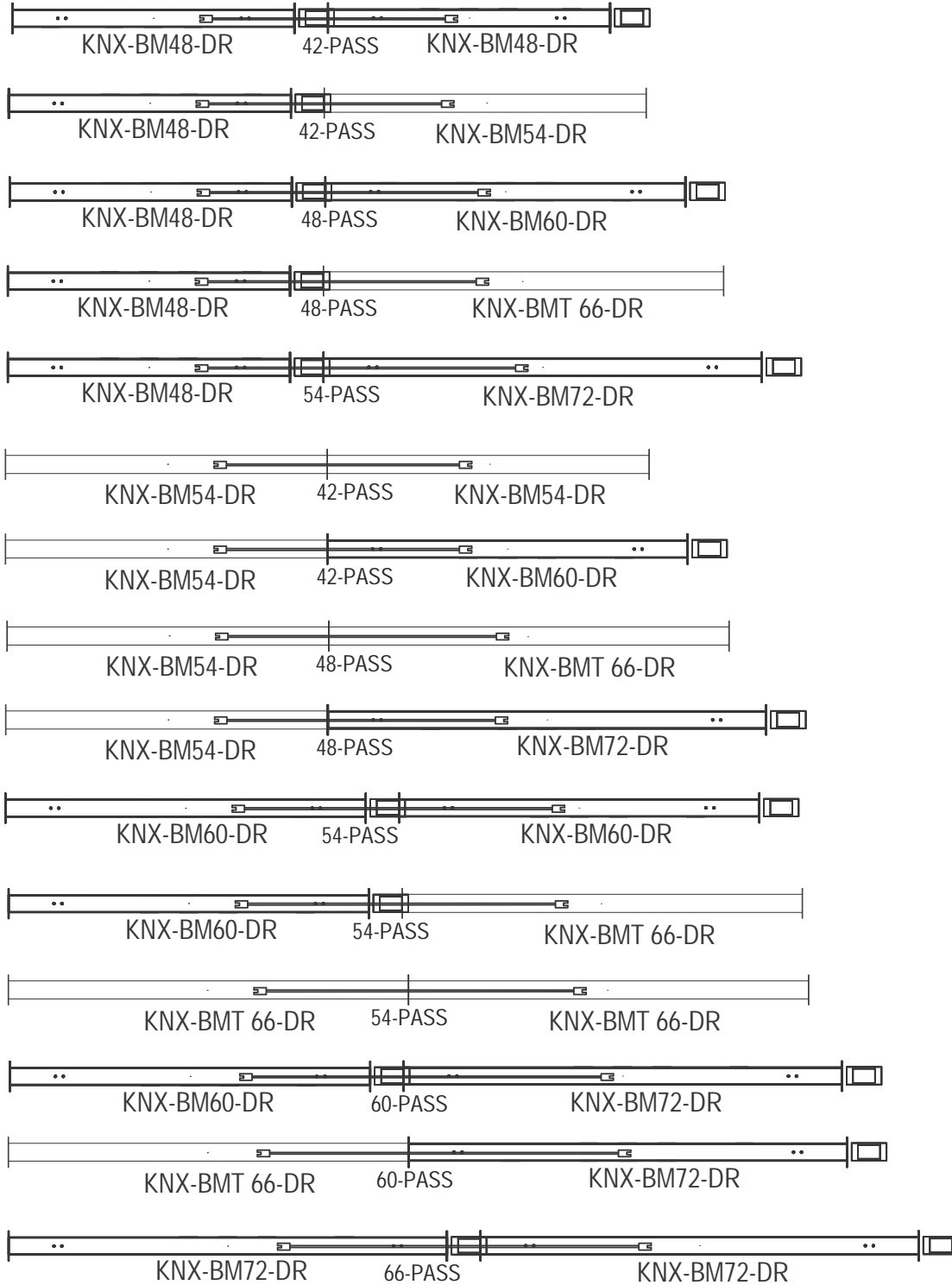
## 4 Circuit/8 Wire Specification



## 3 Circuit/5 Wire Specification



Jumpers — 4 Circuit/8 Wire and 3 Circuit/5 Wire



# KINEX Desks



Tip: Base supports a maximum distributed weight capacity of 265 pounds. When calculating lifting capacity, subtract the weight of the worksurface.

Tip: Actual depths are 23" and 29".

Tip: End panel(s) are not available on single-run application.

Tip: Fixed height does not have a hand set option or a power cord.

Standard Includes	Required to Specify
<ul style="list-style-type: none"> <li>Fixed or adjustable base:                             <ul style="list-style-type: none"> <li>Black</li> <li>Platinum</li> <li>White</li> </ul> </li> <li>Power beam for single and double run application: includes two data faceplates, two bottom caps, six plastic front covers, two plastic side covers, and one bridge connector</li> <li>Crossbeam for double run application: includes two double run plastic side covers</li> <li>Benching set of two feet for single run application</li> <li>Power cord: 9'</li> <li>Attachment hardware</li> <li>Laminate worksurface</li> </ul>	<ol style="list-style-type: none"> <li>Style number</li> <li>Laminate color number for worksurface</li> <li>Paint color number for base</li> <li>Options, if selected (see below)                             <ul style="list-style-type: none"> <li>▶ See <i>Surface Materials</i>, page 506.</li> </ul> </li> </ol>

Options	U.S. Price	Required to Specify
<b>End Panel</b> <ul style="list-style-type: none"> <li>One end panel 24"D +\$247</li> <li>One end panel 30"D +\$273</li> <li>Two end panels 24"D +\$494</li> <li>Two end panels 30"D +\$546</li> </ul>		Specify with one end panel 24"D. Specify with one end panel 30"D. Specify with two end panels 24"D. Specify with two end panels 30"D.
<b>Hand Set</b> <ul style="list-style-type: none"> <li>Standard No cost</li> <li>4 pre-set—single run +\$103</li> <li>4 pre-set—double run +\$206</li> </ul>		Specify with standard hand set. Specify with 4 pre-set single run hand set. Specify with 4 pre-set double run hand set.

## Specification Information

Style Number	Dimensions Depth	U.S. Base Prices Width				
		48"W	54"W	60"W	66"W	72"W

### KINEX Fixed Desk — Single Run

KINXBENCH	24"	\$1452	\$1500	\$1541	\$1595	\$1643
	30"	\$1523	\$1570	\$1589	\$1659	\$1698

### KINEX 2 Stage Desk — Single Run

KINXBENCH	24"	\$2472	\$2520	\$2561	\$2615	\$2663
	30"	\$2543	\$2590	\$2609	\$2679	\$2718

### KINEX 3 Stage Desk — Single Run

KINXBENCH	24"	\$2623	\$2671	\$2712	\$2766	\$2814
	30"	\$2694	\$2741	\$2760	\$2830	\$2869

### KINEX Fixed Desk — Double Run

KINXBENCH	24"	\$2672	\$2762	\$2838	\$2931	\$3022
	30"	\$2804	\$2892	\$2924	\$3049	\$3122

### KINEX 2 Stage Desk — Double Run

KINXBENCH	24"	\$4712	\$4802	\$4878	\$4971	\$5062
	30"	\$4844	\$4932	\$4964	\$5089	\$5162

### KINEX 3 Stage Desk — Double Run

KINXBENCH	24"	\$5014	\$5104	\$5180	\$5273	\$5364
	30"	\$5146	\$5234	\$5266	\$5391	\$5464



**For Canadian Pricing**  
Multiply U.S. Price by the Canadian price factor.  
▶ See page 1 for details.



Tip: Base supports a maximum distributed weight capacity of 265 pounds. When calculating lifting capacity, subtract the weight of the worksurface.

Tip: Fixed height does not have a hand set option or a power cord.

Standard Includes	Required to Specify
<ul style="list-style-type: none"> <li>Fixed or adjustable base:                             <ul style="list-style-type: none"> <li>– Black</li> <li>– Platinum</li> <li>– White</li> </ul> </li> <li>Power beam for single and double run application: includes two data faceplates, two bottom caps, six plastic front covers, two plastic side covers, and one bridge connector</li> <li>Crossbeam for double run application: includes two double run plastic side covers</li> <li>Benching set of two feet for single run application</li> <li>Power cord: 9'</li> <li>Attachment hardware</li> </ul>	<ul style="list-style-type: none"> <li>1 Style number</li> <li>2 Paint color number for base</li> <li>3 Options, if selected (see below)</li> <li>▶ See <i>Surface Materials</i>, page 506.</li> </ul>

Options	U.S. Price	Required to Specify
<b>Hand Set</b>		
<ul style="list-style-type: none"> <li>Standard</li> <li>4 pre-set—single run</li> <li>4 pre-set—double run</li> </ul>	<ul style="list-style-type: none"> <li>No cost</li> <li>+\$103</li> <li>+\$206</li> </ul>	<ul style="list-style-type: none"> <li>Specify with standard hand set.</li> <li>Specify with 4 pre-set single run hand set.</li> <li>Specify with 4 pre-set double run hand set.</li> </ul>

### Specification Information

Style Number	Dimensions Depth	U.S. Base Prices				
		Width				
		48"W	54"W	60"W	66"W	72"W

#### KINEX Fixed Base — Single Run

KINXBASE	Depth	48"W	54"W	60"W	66"W	72"W
	24"	\$1138	\$1144	\$1150	\$1165	\$1170
	30"	\$1153	\$1159	\$1165	\$1180	\$1185

#### KINEX 2 Stage Base — Single Run

KINXBASE	Depth	48"W	54"W	60"W	66"W	72"W
	24"	\$2158	\$2164	\$2170	\$2185	\$2190
	30"	\$2173	\$2179	\$2185	\$2200	\$2205

#### KINEX 3 Stage Base — Single Run

KINXBASE	Depth	48"W	54"W	60"W	66"W	72"W
	24"	\$2309	\$2315	\$2321	\$2336	\$2341
	30"	\$2324	\$2330	\$2336	\$2351	\$2356

#### KINEX Fixed Base — Double Run

KINXBASE	Depth	48"W	54"W	60"W	66"W	72"W
	24"	\$2044	\$2050	\$2056	\$2071	\$2076
	30"	\$2064	\$2070	\$2076	\$2091	\$2096

#### KINEX 2 Stage Base — Double Run

KINXBASE	Depth	48"W	54"W	60"W	66"W	72"W
	24"	\$4083	\$4089	\$4096	\$4110	\$4116
	30"	\$4105	\$4111	\$4117	\$4132	\$4137

#### KINEX 3 Stage Base — Double Run

KINXBASE	Depth	48"W	54"W	60"W	66"W	72"W
	24"	\$4386	\$4392	\$4398	\$4413	\$4418
	30"	\$4406	\$4412	\$4418	\$4433	\$4438

**For Canadian Pricing**  
 Multiply U.S. Price by the Canadian price factor.  
 ▶ See page 1 for details.



# KINEX Worksurface



Standard Includes	Required to Specify
<ul style="list-style-type: none"> <li>Laminate worksurface</li> </ul>	1 Style number 2 Laminate color number for worksurface

## Specification Information

Style Number	Dimensions Depth	U.S. Prices				
		Width				
		48"W	54"W	60"W	66"W	72"W
<b>KINXWORKSURFACE</b>	24"	\$314	\$356	\$391	\$430	\$473
	30"	\$370	\$411	\$424	\$479	\$513



**For Canadian Pricing**  
 Multiply U.S. Price by the Canadian price factor.  
 ▶ See page 1 for details.



Standard Includes	Required to Specify
-------------------	---------------------

- End panel: paint
- Attachment hardware

- 1 Style number
- 2 Paint color number for end panel
- ▶ See *Surface Materials*, page 506.

Specification Information		
• Style Number	• Depth	• U.S. Price
<b>KINXENDPANEL</b>	24"	\$247
	30"	\$273

• Style Number	• Depth	• U.S. Price
<b>KINXENDPANEL</b>	24"	\$247
	30"	\$273



 **For Canadian Pricing**  
 Multiply U.S. Price by the Canadian price factor.  
 ▶ See page 1 for details.

# KINEX Accessories

## KINEX Feet

Tip: For single run application only.

Standard Includes		Required to Specify
<ul style="list-style-type: none"> <li>Set of two feet: paint</li> </ul>		1 Style number 2 Paint color number for feet ▶ See <i>Surface Materials</i> , page 506.

Specification Information		
Style Number	Depth	U.S. Price
KINXFEET	24"	\$116
	30"	\$131

## KINEX Cross Beam

Standard Includes		Required to Specify
<ul style="list-style-type: none"> <li>Cross beam: paint</li> </ul>		1 Style number 2 Paint color number for beam ▶ See <i>Surface Materials</i> , page 506.

Specification Information		
Style Number	Depth	U.S. Price
KINXCROSSBEAM	24"	\$241
	30"	\$261

## KINEX Beam

Standard Includes		Required to Specify				
<ul style="list-style-type: none"> <li>Beam: paint</li> </ul>		1 Style number 2 Paint color number for beam ▶ See <i>Surface Materials</i> , page 506.				

Specification Information						
Style Number		U.S. Prices				
		Width				
		48"W	54"W	60"W	66"W	72"W
KINXBEAM	Single Run	\$241	\$247	\$253	\$268	\$273
	Double Run	\$241	\$247	\$253	\$268	\$273



**For Canadian Pricing**  
 Multiply U.S. Price by the Canadian price factor.  
 ▶ See page 1 for details.

---

# ILINE



**Understanding**

**36**



**Specifying**

**46**

ILINE

# Statement of Line

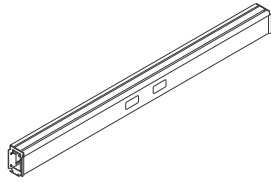
## Frames



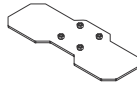
90°/180° Post  
(2-way, 3-way, 4-way)



120° Post  
(3-way)



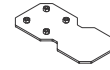
Beam



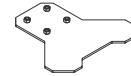
DR End Foot



DR Center Foot

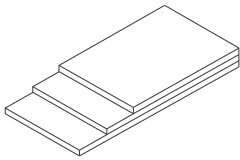


SR End Foot

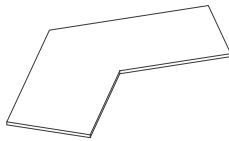


SR Center Foot

## Worksurfaces

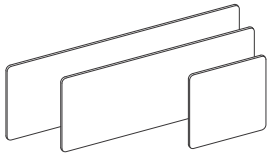


Linear

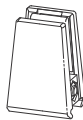


120°  
with ACTIV PRO 3

## Privacy Screens & Panels



3F Screens

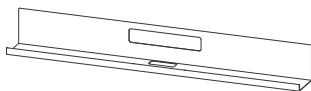


Screen Mounting Clip



Kinex Screen Mounting Clip

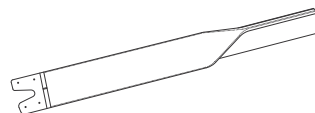
## Accessories



Iline Wire Tray



Cable Management Track

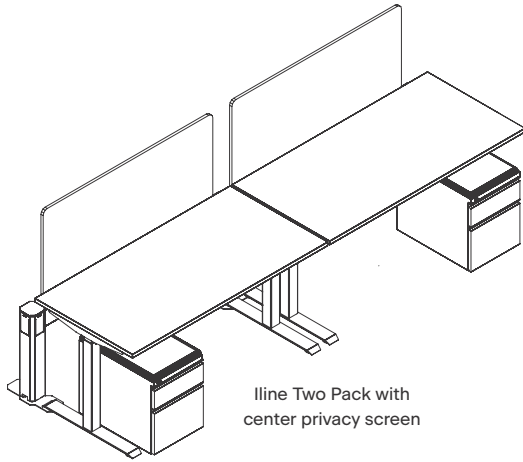


Soft Cable Management

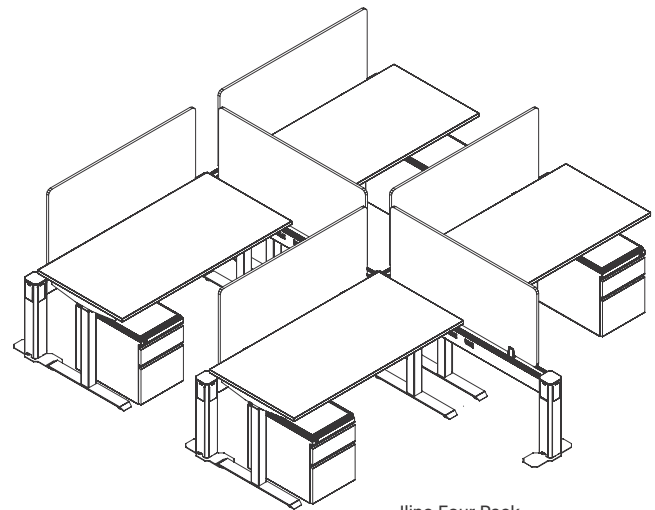


# Typical Configurations

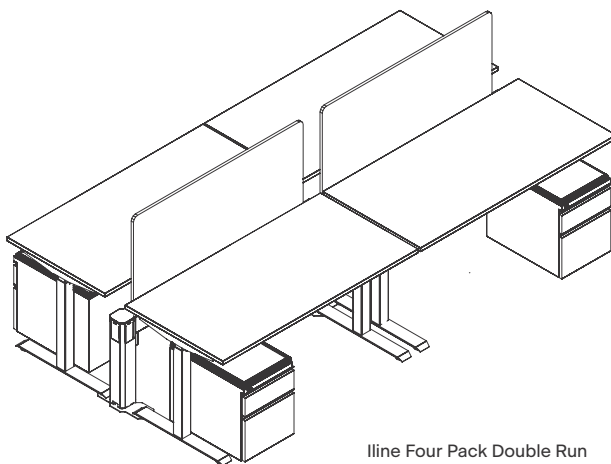
A full gallery of typicals is available on our web site.  
Each typical includes CET file, specifications, rendering and 2D layout.



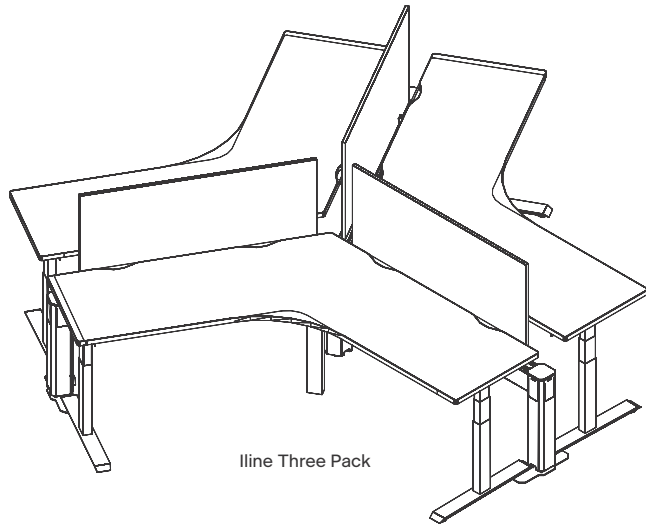
Iline Two Pack with  
center privacy screen



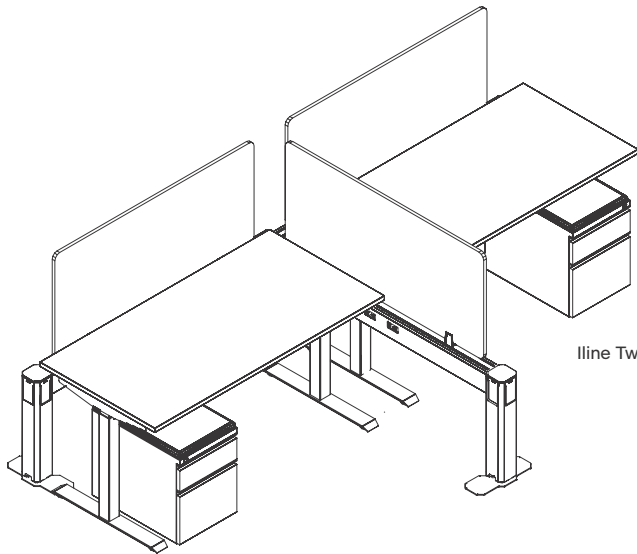
Iline Four Pack



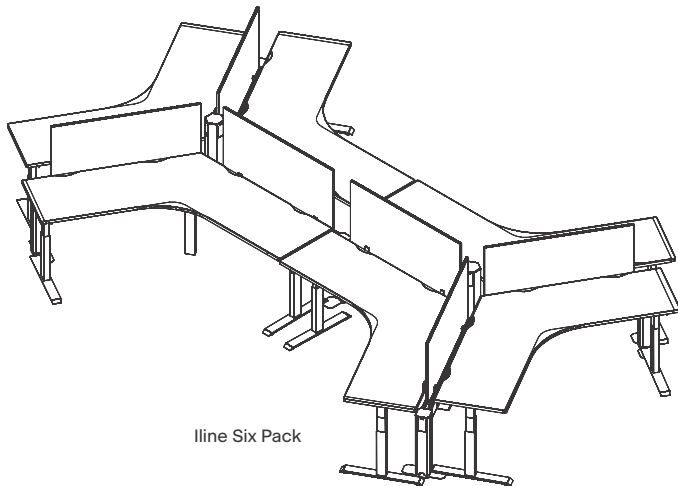
Iline Four Pack Double Run



Iline Three Pack



Iline Two Pack Single Run

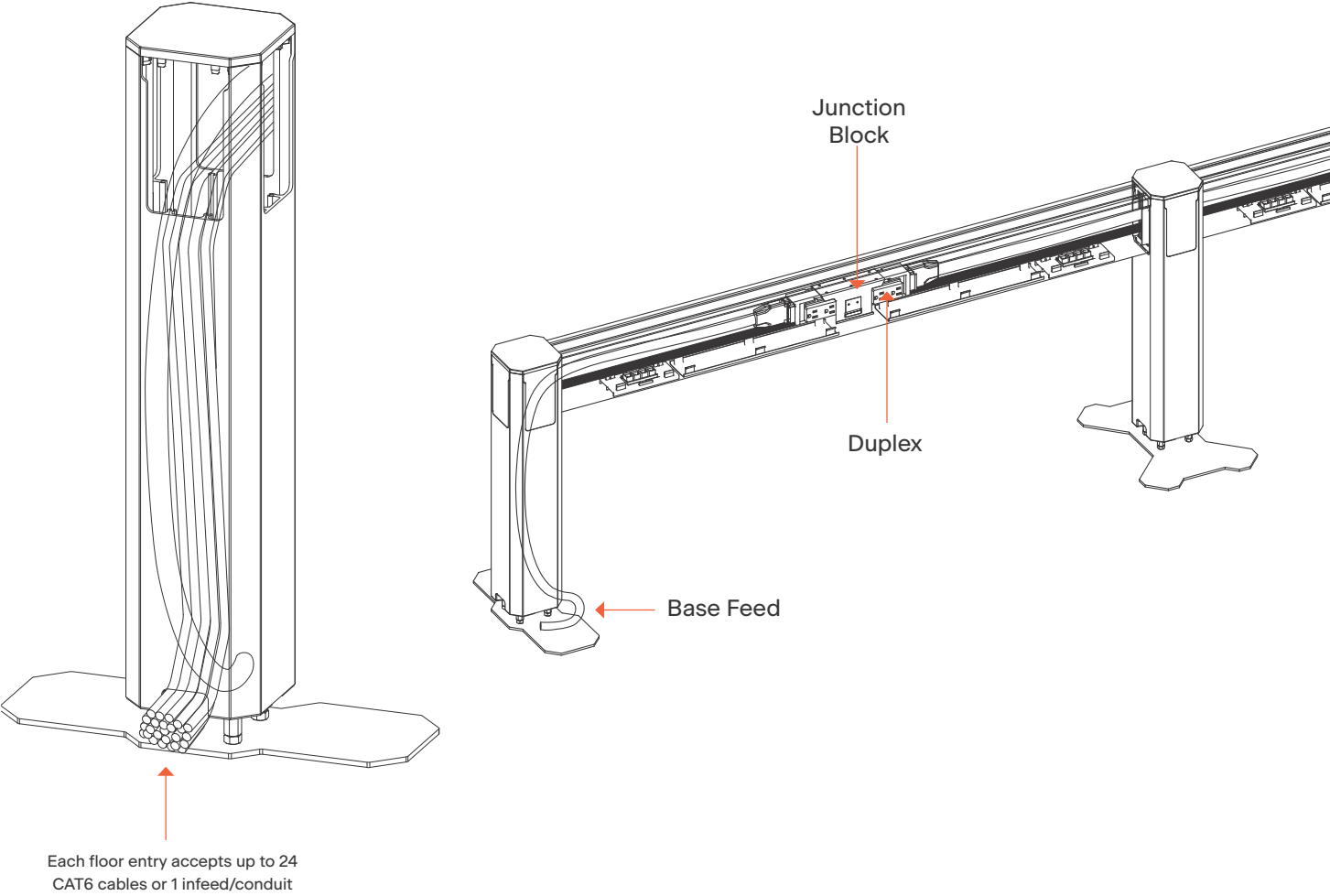


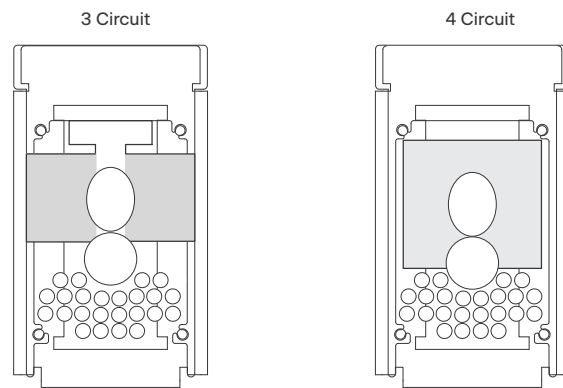
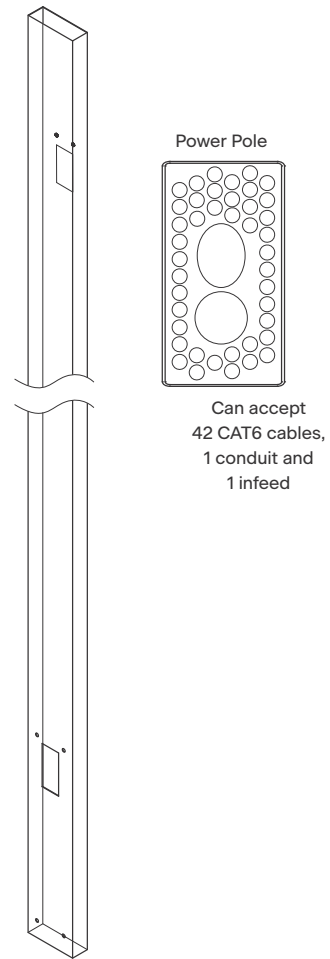
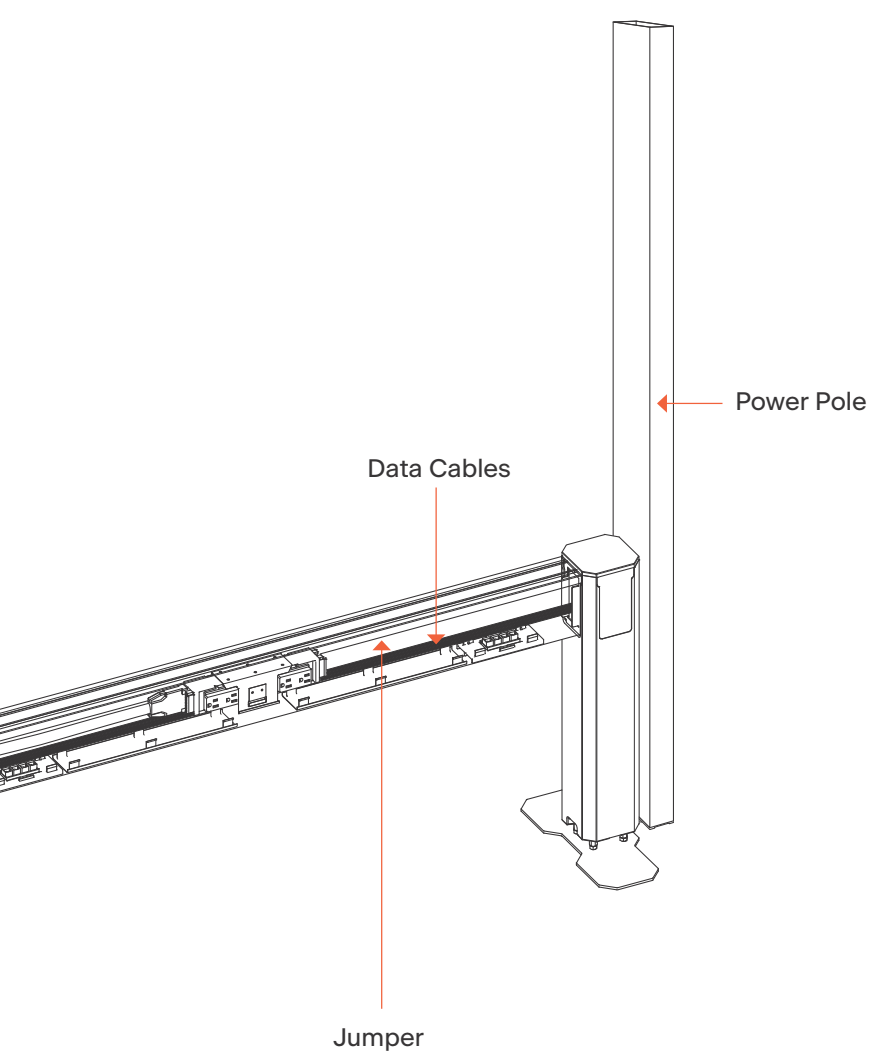
Iline Six Pack

# Electrical

iLINE beam technology distributes electrical with either 3 circuit/5 wire or 4 circuit/8 wire.

iLine power/data beam



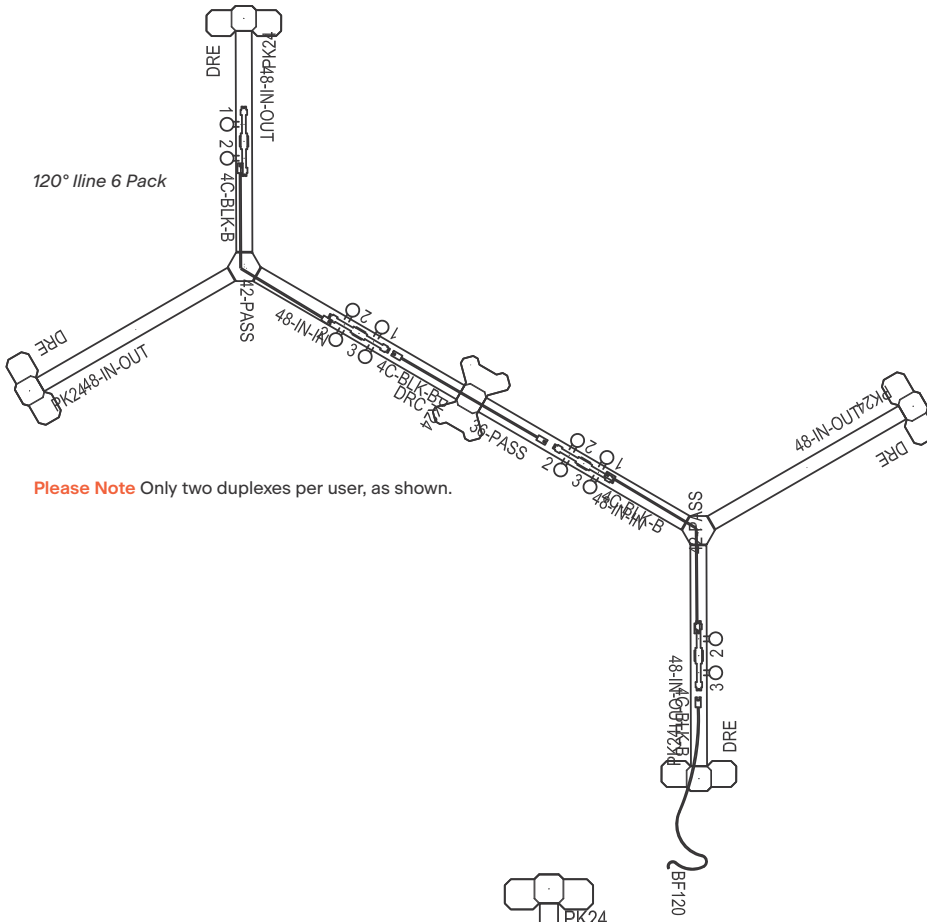


Accepts 24 CAT6 cables, 1 conduit and 1 infeed

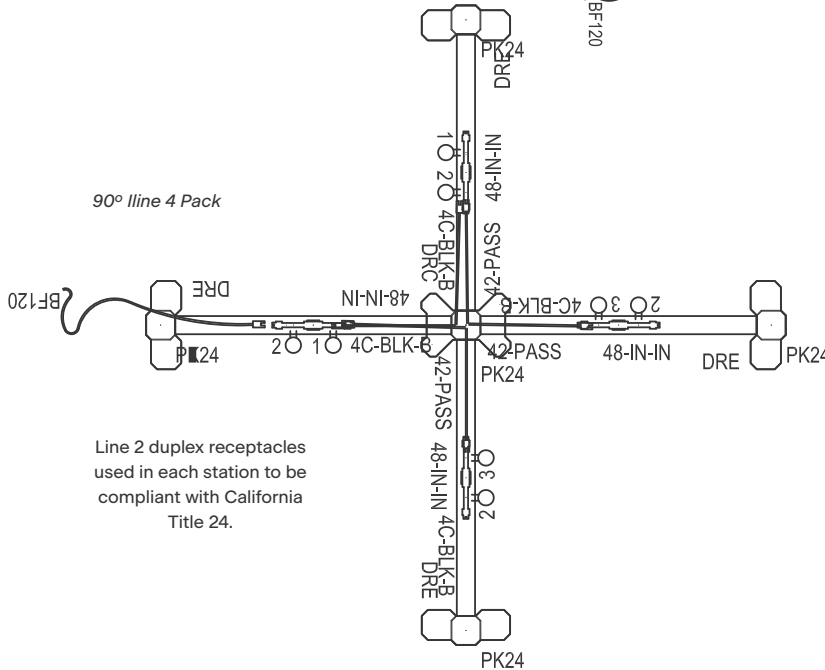
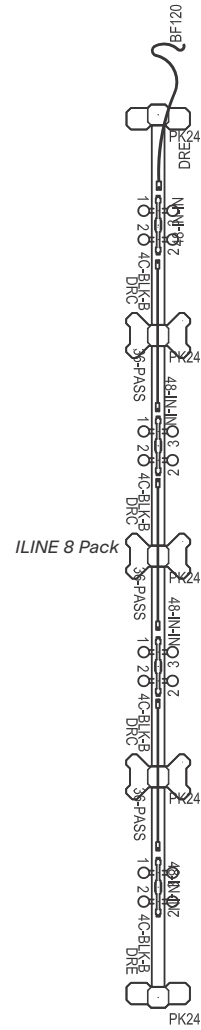
# Electrical

Examples of how to specify ILINE in 3 different configurations.

## 4 Circuit/8 Wire

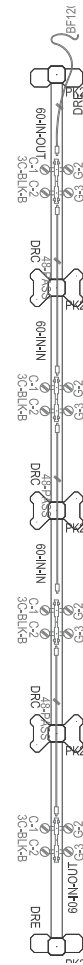
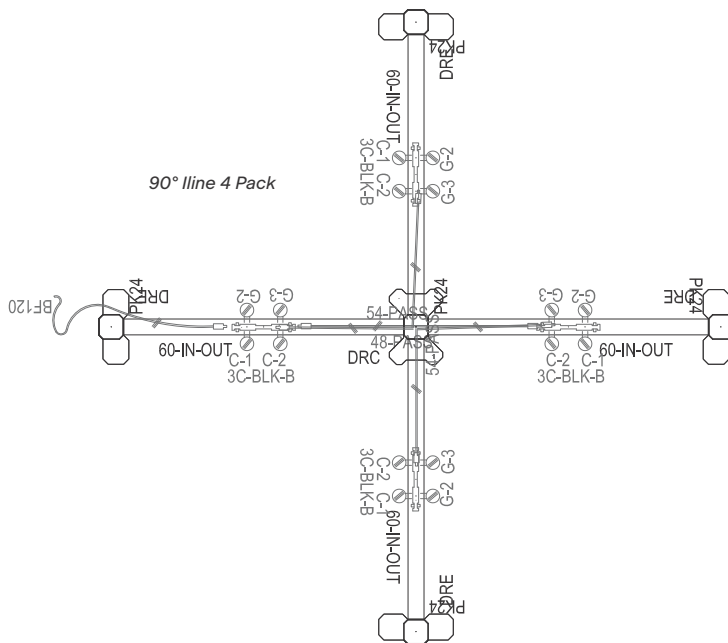
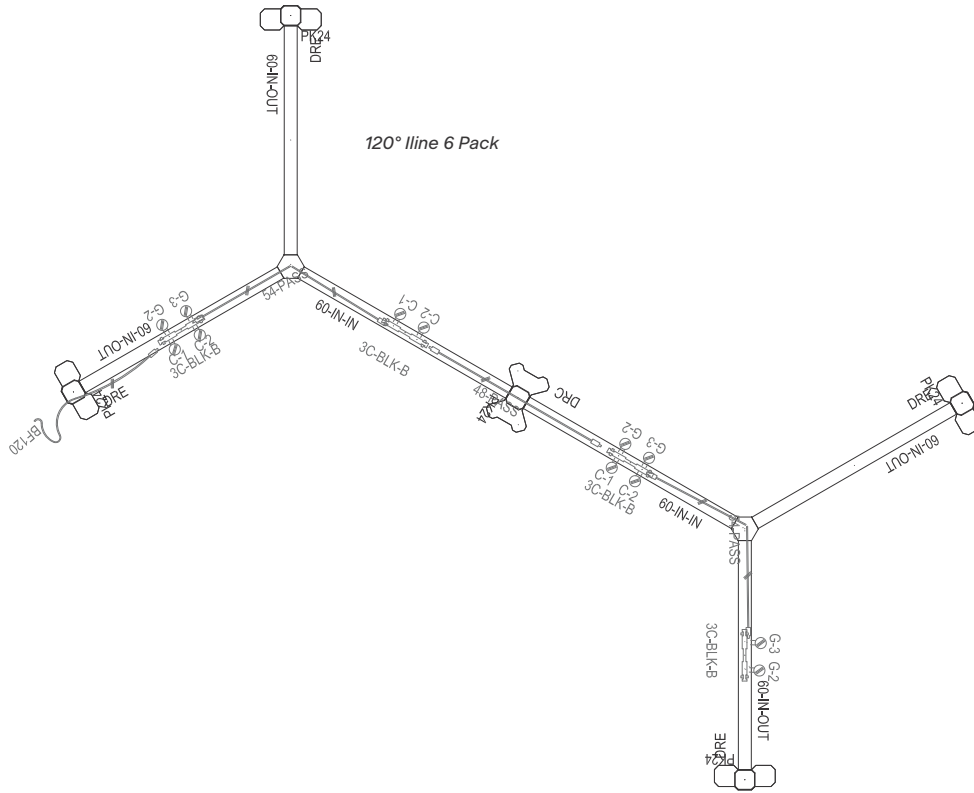


**Please Note** Only two duplexes per user, as shown.



Line 2 duplex receptacles used in each station to be compliant with California Title 24.

3 Circuit/5 Wire

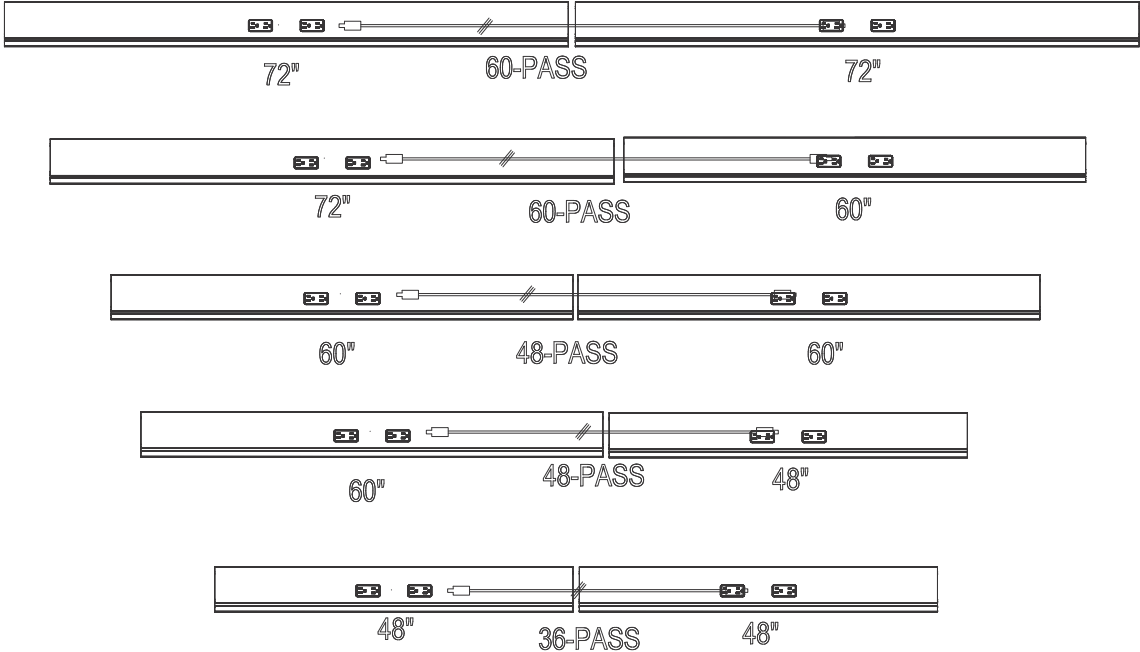


Iline 8 Pack

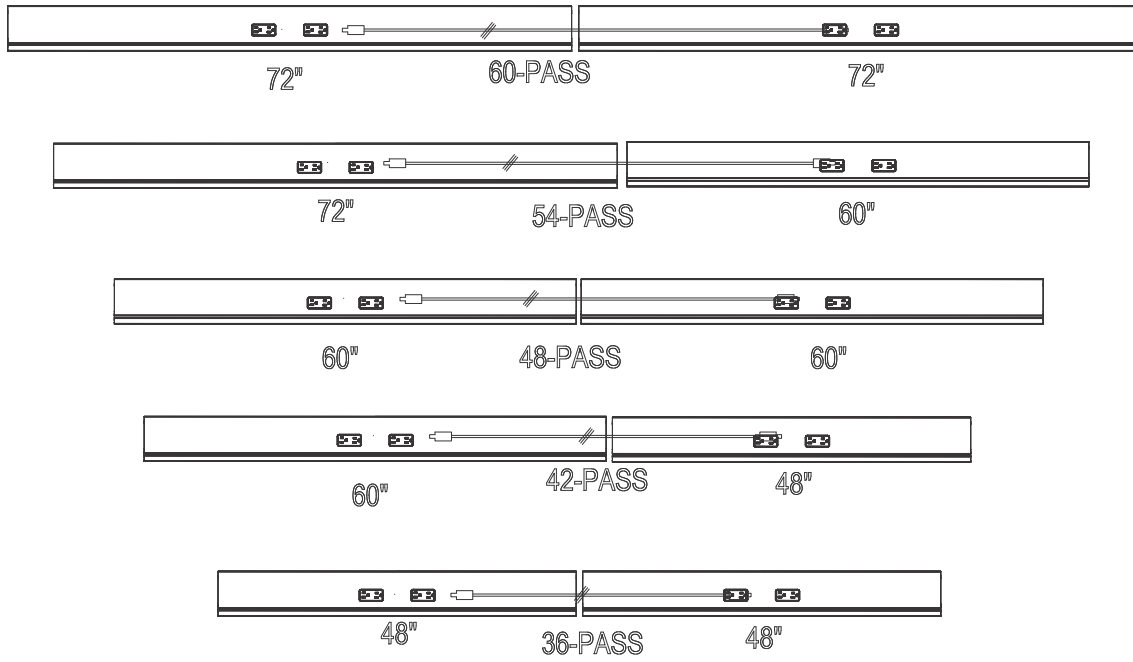
Iline power/data beam

# Electrical

## Jumpers (4 Circuit/8 Wire)



Jumpers (3 Circuit/5 Wire)



# ILINE Beam



Standard Includes	Required to Specify
<ul style="list-style-type: none"> <li>• Two beam plates: paint</li> <li>• Two bridge connectors</li> <li>• Two receptacle covers</li> <li>• Two data adapters with data faceplates and hardware</li> </ul>	<ul style="list-style-type: none"> <li>1 Style number</li> <li>2 Paint color number for plates</li> <li>▶ See <i>Surface Materials</i>, page 506.</li> </ul>

Specification Information			
• Style • Number	• U.S. Prices		
	• Width		
	48"W	60"W	72"W
<b>ILNEBEAM</b>	\$477	\$540	\$608



**For Canadian Pricing**  
 Multiply U.S. Price by the  
 Canadian price factor.  
 ▶ See page 1 for details.



Standard Includes	Required to Specify
<ul style="list-style-type: none"> <li>• Post, post top cap, and base plate: paint</li> <li>• Three side covers: plastic</li> <li>• Glides</li> <li>• Hardware</li> </ul>	<ul style="list-style-type: none"> <li>1 Style number</li> <li>2 Paint color number for plates</li> <li>3 Plastic color number for covers</li> <li>▶ See <i>Surface Materials</i>, page 506.</li> </ul>

Specification Information		
• Style Number	• U.S. Prices	
•	• 90°/180°	• 120°
<b>ILNEPOST</b>	\$358	\$372
•	•	•



 **For Canadian Pricing**  
 Multiply U.S. Price by the Canadian price factor.  
 ▶ See page 1 for details.

# ILINE Base Kits



Standard Includes	Required to Specify
<ul style="list-style-type: none"> <li>• Base plate and hardware: paint</li> </ul>	<ul style="list-style-type: none"> <li>1 Style number</li> <li>2 Paint color number for plates</li> <li>▶ See <i>Surface Materials</i>, page 506.</li> </ul>

## Specification Information

• Style Number	• U.S. Price
<b>End Foot — Single Run</b>	
ILNEBASE	\$ 92
<b>End Foot — Double Run</b>	
ILNEBASE	\$111
<b>Center Foot — Single Run</b>	
ILNEBASE	\$104
<b>Center Foot — Double Run</b>	
ILNEBASE	\$131



**For Canadian Pricing**  
 Multiply U.S. Price by the Canadian price factor.  
 ▶ See page 1 for details.

---

# Power & Data

**Specifying**

**50**

# Power & Data

## ILINE Power Pole

Standard Includes		Required to Specify
<ul style="list-style-type: none"> <li>Power pole: paint</li> </ul>		1 Style number 2 Paint color number for pole ▶ See <i>Surface Materials</i> , page 506.
Specification Information		
Style Number	U.S. Price	
ILNEPOWERPOLE	\$540	

## KINEX Power Pole

Standard Includes		Required to Specify	
<ul style="list-style-type: none"> <li>Power pole: paint</li> <li>Attachment hardware</li> </ul>		1 Style number 2 Paint color number for pole ▶ See <i>Surface Materials</i> , page 506.	
Options	U.S. Price	Required to Specify	
Run	<ul style="list-style-type: none"> <li>Double run</li> <li>Single run</li> </ul>	No cost	Specify <i>with double run</i> .
		No cost	Specify <i>with single run</i> .
Specification Information			
Style Number	U.S. Price		
KINXPOWERPOLE	\$568		



**For Canadian Pricing**  
 Multiply U.S. Price by the Canadian price factor.  
 ▶ See page 1 for details.

## Power Entry



Tip: Used on both ILINE and KINEX desks and bases.

Standard Includes	Required to Specify
• Power entry	Style number

### Specification Information

Style Number	U.S. Price
<b>3-Circuit — Base Feed</b>	
PWRENTY	\$282
<b>3-Circuit — Ceiling Power Pole</b>	
PWRENTY	\$335
<b>3-Circuit — New York City Base Feed</b>	
PWRENTY	\$376
<b>3-Circuit — San Francisco Base Feed</b>	
PWRENTY	\$370
<b>4-Circuit — Base Feed</b>	
PWRENTY	\$376
<b>4-Circuit — Ceiling Power Pole</b>	
PWRENTY	\$411
<b>4-Circuit — New York City Base Feed</b>	
PWRENTY	\$452
<b>4-Circuit — San Francisco Base Feed</b>	
PWRENTY	\$473

Power & Data



**For Canadian Pricing**  
 Multiply U.S. Price by the Canadian price factor.  
 ▶ See page 1 for details.

## Corded Power Entry Base Feed



*Tip: Used on both ILINE and KINEX desks and bases.*

*Tip: Softwire base feeds should only be specified with line-1 duplexes.*

*Tip: Softwire base feeds are only recommended for applications that require limited power capacity (showrooms, demos, or touchdown workstations).*

Standard Includes	Required to Specify
<ul style="list-style-type: none"> <li>Power entry</li> </ul>	Style number

### Specification Information

Style Number	U.S. Price

#### 72" 3-Circuit

<b>X-E3-BF-CD72</b>	\$271

#### 72" 4-Circuit

<b>X-E4-BF-CD72</b>	\$222

## KINEX Double Sided Double Junction Block



Standard Includes	Required to Specify
<ul style="list-style-type: none"> <li>Double sided double junction block</li> <li>Two junction block brackets</li> </ul>	Style number

### Specification Information

Style Number	U.S. Price

#### 3-Circuit

<b>KINXDBLJUNCTIONBLK</b>	\$158

#### 4-Circuit

<b>KINXDBLJUNCTIONBLK</b>	\$206

## KINEX Double Sided Single Junction Block



Standard Includes	Required to Specify
<ul style="list-style-type: none"> <li>Double sided single junction block</li> <li>Junction block bracket</li> </ul>	Style number

### Specification Information

Style Number	U.S. Price

<b>KINXSGLJUNCTIONBLK</b>	\$192



**For Canadian Pricing**  
 Multiply U.S. Price by the Canadian price factor.  
 ▶ See page 1 for details.

## ILINE Double Sided Junction Block



Standard Includes	Required to Specify
<ul style="list-style-type: none"> <li>• Double sided junction block</li> </ul>	Style number

### Specification Information

Style Number	U.S. Price

#### 3-Circuit

PWRJUNCTIONBLK	\$151

#### 4-Circuit

PWRJUNCTIONBLK	\$196

## ILINE Chicago Power Box



Standard Includes	Required to Specify
<ul style="list-style-type: none"> <li>• Power supply: paint</li> </ul>	1 Style number 2 Paint color number for frame ▶ See <i>Surface Materials</i> , page 506.

### Specification Information

Style Number	U.S. Price

ILNECHIPWR	\$347

Power & Data

## KINEX Chicago Power Box



Standard Includes	Required to Specify
<ul style="list-style-type: none"> <li>• Power supply: paint</li> </ul>	1 Style number 2 Paint color number for box ▶ See <i>Surface Materials</i> , page 506.

### Specification Information

Style Number	U.S. Price

KINXCHIPWR	\$364

**For Canadian Pricing**  
 Multiply U.S. Price by the Canadian price factor.  
 ▶ See page 1 for details.

## KINEX Power C Receptacle



Standard Includes	Required to Specify
-------------------	---------------------

- Power supply: plastic

- 1 Style number
  - 2 Plastic color number for receptacle
  - 3 Options, if selected (see below)
- ▶ See *Surface Materials*, page 506.

	Options	U.S. Price	Required to Specify
--	---------	------------	---------------------

<b>Circuit</b>	• 3-circuit	No cost	Specify <i>with 3-circuit</i> .
	• 4-circuit	No cost	Specify <i>with 4-circuit</i> .

<b>Power Schematics</b>	• Line 1	No cost	Specify <i>with line 1</i> .
	• Line 2	No cost	Specify <i>with line 2</i> .
	• Line 3	No cost	Specify <i>with line 3</i> .
	• Line 4	No cost	Specify <i>with line 4</i> .

### Specification Information

Style Number	U.S. Price
PWRCRECEPTACLE	\$41

## ILINE G-Power Receptacle



Standard Includes	Required to Specify
-------------------	---------------------

- Receptacle: plastic

- 1 Style number
  - 2 Plastic color number for receptacle
  - 3 Options, if selected (see below)
- ▶ See *Surface Materials*, page 506.

	Options	U.S. Price	Required to Specify
--	---------	------------	---------------------

<b>Circuit</b>	• 3-circuit	No cost	Specify <i>with 3-circuit</i> .
	• 4-circuit	No cost	Specify <i>with 4-circuit</i> .

<b>Power Schematics</b>	• Line 1	No cost	Specify <i>with line 1</i> .
	• Line 2	No cost	Specify <i>with line 2</i> .
	• Line 3	No cost	Specify <i>with line 3</i> .
	• Line 4	No cost	Specify <i>with line 4</i> .

### Specification Information

Style Number	U.S. Price
PWGRRECEPTACLE	\$39



#### For Canadian Pricing

Multiply U.S. Price by the Canadian price factor.

▶ See page 1 for details.

## Adjustable Jumper Adapter



Tip: Used on both ILINE and KINEX desks and bases.

Standard Includes	Required to Specify
• Adjustable jumper	Style number

### Specification Information

Style Number	U.S. Prices						
	36"W	42"W	48"W	54"W	60"W	66"W	72"W

### 3-Circuit

PWRJUMPER	36"W	42"W	48"W	54"W	60"W	66"W	72"W
	\$116	\$123	\$131	\$137	\$142	\$151	\$164

### 4-Circuit

PWRJUMPER	36"W	42"W	48"W	54"W	60"W	66"W	72"W
	\$171	\$178	\$198	\$206	\$219	\$226	\$247

## 3-Circuit Y Connector



Tip: Used on both ILINE and KINEX desks and bases.

Standard Includes	Required to Specify
• Power connector	Style number

### Specification Information

Style Number	U.S. Price
X-E3-YC	\$41

 **For Canadian Pricing**  
 Multiply U.S. Price by the Canadian price factor.  
 ▶ See page 1 for details.



---

# ACTIV PRO 2.0

<b>Understanding</b>	<b>58</b>
<b>Specifying</b>	<b>68</b>

# ACTIV PRO 2.0 Height-Adjustable Desks and Bases

**ACTIV PRO 2.0** supports wellbeing at work by allowing users to move between seated and standing postures throughout the workday.  
 ▶ Specifying, page 68

**Telescoping frame** adjusts to fit any worksurface width from 44"W–72"W.

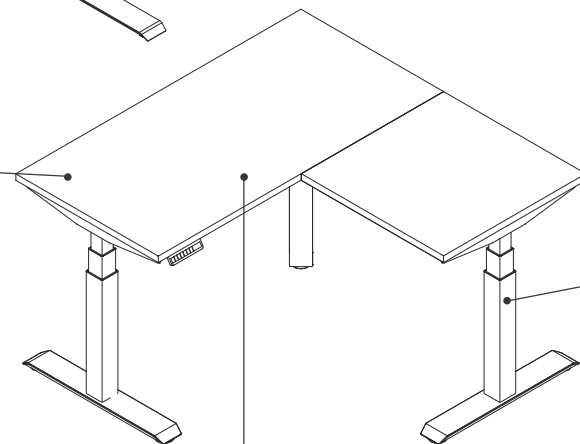
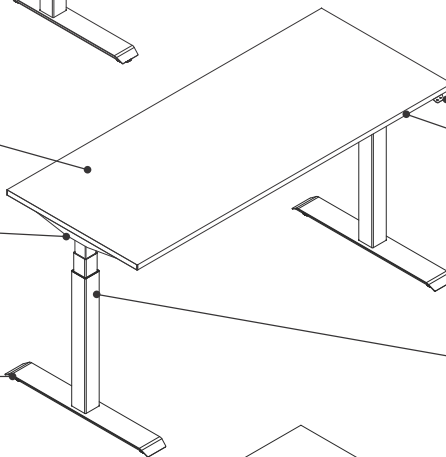
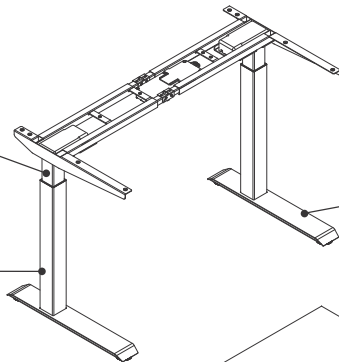
**The 2-stage desk** adjusts from 27"H–46.7"H.

**Desk** has a wood core with a Low-Pressure Laminate worksurface and is 1" thick.

**Internal motors with electronic synchronization drive.**

**Leveling glides** adjust ½" to install desk on uneven floors.

**ACTIV PRO 2.0 desks** are available in 90 degree and 120 degree 3-leg configurations.



**Bases** support a maximum distributed weight capacity of 225 pounds (2-stage) and 250 pounds (3-stage).  
*Tip: When calculating lifting capacity, subtract weight of the worksurface.*

**Push button with four programmable settings** adjusts from 1 7/10" inches per second.

**Edge** is available in 3 mm edge profile.

**The 3-stage desk** adjusts from 22.6"H–48.7"H.

**ACTIV PRO 2.0** offers both T- and C-leg configuration for the rectangle desk.

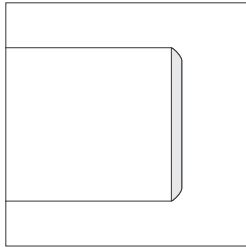
**The 3-leg desks** have a height range of 22.6"–48.7".

**The 3-leg corner desks** are available in T-leg configurations.

## Product Details

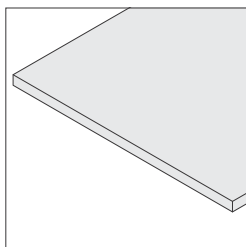
### Low-Pressure Laminate

**Front (user's) edge profile** is available in 3 mm edge profile.



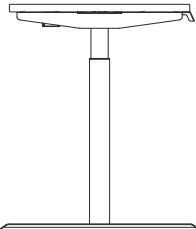
**PVC-free, 3 mm edge profiles with matching 1 mm side and back edges** are also PVC-free. ▶ See *Surface Materials* in this book for specific PVC-free availability, page 505.

**Edge profile finishes** always match laminate finishes.

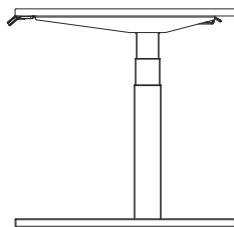


**Square corners** are standard and have 90° corners on all four sides.

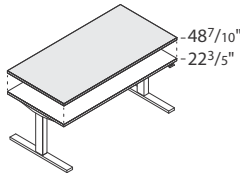
**Overhang** is available. The maximum overhang available as a standard option is 15"W.



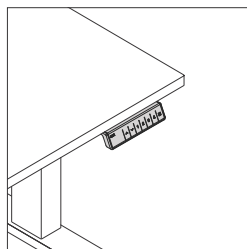
**T-leg configuration** is available on ACTIV PRO 2.0 in 23"/24" and 29"/30" depth worksurface options. Corner desks are available in a T-leg configuration.



**3-leg configuration** is available on ACTIV PRO 2.0 in 23"/24" and 29"/30" depth worksurface options.



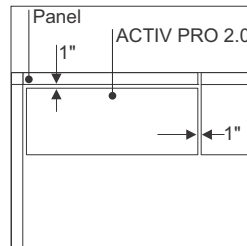
**ACTIV PRO 2.0** 3-stage desk adjusts from 22<sup>3</sup>/<sub>5</sub>"H–48<sup>7</sup>/<sub>10</sub>"H, while the 2-stage desk adjusts from 27"H–46<sup>7</sup>/<sub>10</sub>"H in any increment.



**4 pre-set programmable controller** allows users to set the seated and standing height positions or pre-set heights for multiple users. When activated, the digital display will show the height of desk.

**Obstruction sensing technology** is standard with all ACTIV PRO 2.0 desks. The worksurface will backtrack when it makes contact with an object.

**Casters** are available as an option on ACTIV PRO 2.0. The front two casters lock while the back two casters do not.



**Rectangle and 3-leg corner desk sizes** are listed in actual dimensions to allow for 1" gap to adjacent furniture eliminating any pinch points.

## Wiring and Cabling

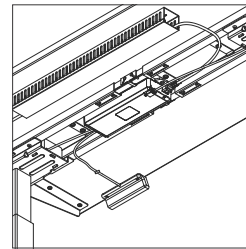
**Electric motor with whisper quiet operation** adjusts at 1<sup>3</sup>/<sub>10</sub>" per second. Motor is 24V DC and includes a 9' power cord. Motor for 2-leg and 3-leg desks have a 0.2W standby power.

**ACTIV PRO 2.0 desks and bases** are listed by ETL.

▶ See page 62

**Power and data strips** are field-installed on worksurface. Specify appropriate attachment bracket depending on application.

▶ See page 139 for *Work Tools*.



**Cable management** includes a simple wire tray that screws to the worksurface to help manage desk cables.

**The corner desks** come standard with two simple wire trays to manage cables.

## Surface Materials

### Low-Pressure Laminate Desk

24L0	Graphite Walnut
25L5	Virginia Walnut
25L8	Clear Walnut
26L1	Natural Cherry
2L09	Clear Maple
2L30	Arctic White
2L83	Seagull
2L84	Milk White
2LAW	Ash Wenge
2LCN	Clay Noce
2LCW	Clay Wenge
2LAK	Clear Oak
2LAT	Acacia

### 3 mm edge profile

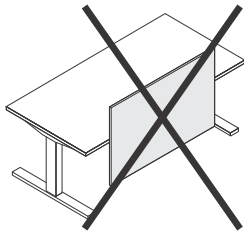
- Plastic

### Height-adjustable base

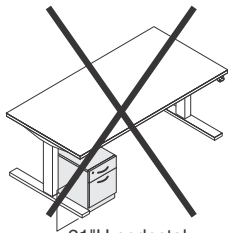
- F1 Platinum
- F2 White
- F3 Black
- F4 Merle

### Application Topics

**Moving desks** can collide with other components. Do not install overhead storage, desk-height power, or desk accessories in the path of height-adjustable desks.



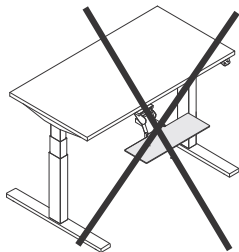
**Universal boundary screens** are not permitted on height-adjustable desks, as they do not pass minimum safety requirements which could result in the desk tipping over.



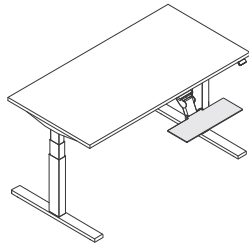
21"H pedestal

**On extended height desks**, any storage higher than 18<sup>3</sup>/<sub>10</sub>" will impede height range of desk. On basic height desks, any storage higher than 24" will impede the height range of the desk.

**All assemblies** meet or exceed ANSI/BIFMA standards.



**Keyboard assemblies** are not allowed on 23"D or smaller than 46"W height-adjustable desks. They do not meet minimum safety requirements.



**Steelcase keyboard assemblies** can be installed on 29"/30"D ACTIV PRO 2.0. Specify with an 11" track.

### WARNING

Read base only warranty limitations.

### Installation

**Height-adjustable base** requires attachment to the worksurface.

**Base** supports a maximum of distributed weight capacity of 225 pounds (2-stage) and 250 pounds (3-stage).

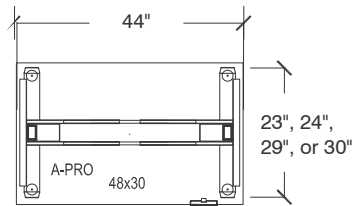


# ACTIV PRO 2.0 2-Stage

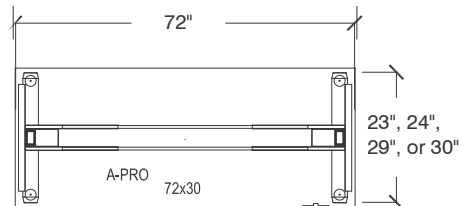


Activ sit-to-stand desk

## Worksurface Sizes



minimum



maximum

# ACTIV PRO 2.0 2-Stage Specifications

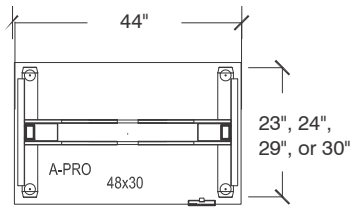
Handset	Push button with 4 programmable settings
Safety	Obstruction detection technology
Foot Length in Inches	23.5" foot for 23"D and 24"D tops. 28.5" foot for 29"D and 30"D tops.
Legs	2 stage, available with T or C Leg
Leg Diameter	2.75" x 2.75"
Height Range (excluding top)	26"–45.7"
Height Range (including top)	27"–46.7"
Frame Width Expansion	width extendable 44"–72" in 1mm increments
Worksurface Widths	46", 48", 52", 54", 58", 60", 64", 66", 70" and 72"
Worksurface Depths	23", 24", 29", and 30"
Max Lifting Capacity	225 lbs
Base Weight Without Top	66 lbs
Gauge of Steel	2mm for inner tube and 1.5mm for outer tube
Speed	33mm/s
Standby Consumption	.2W
ACTIV PRO 2.0e Consumption	Max 350W and Max 5A
Decibel Rating	50db $\leq$
Total Stroke	500 mm
Power Cord	9' cord length with standard NEMA 3 prong plug
Finishes	Platinum, White, Black and Merle
ANSI BIFMA	X5.5
Green Certification	SCS Gold
UL	UL962
Warranty	10 years plus approved labor

# ACTIV PRO 2.0 3-Stage

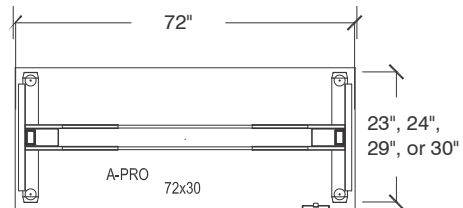


Activ sit-to-stand desk

## Worksurface Sizes



minimum



maximum

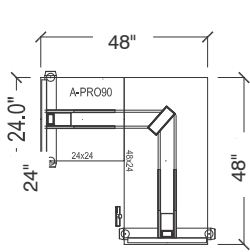
# ACTIV PRO 2.0 3-Stage Specifications

Handset	Push button with 4 programmable settings
Safety	Obstruction detection technology
Foot Length in Inches	23.5" foot for 23"D and 24"D tops. 28.5" foot for 29"D and 30"D tops.
Legs	3 stage, available with T or C Leg
Leg Diameter	2.75" x 2.75"
Height Range (excluding top)	21.6"–47.7"
Height Range (including top)	22.6"–48.7"
Frame Width Expansion	width extendable 44"–72" in 1mm increments
Worksurface Widths	46", 48", 52", 54", 58", 60", 64", 66", 70" and 72"
Worksurface Depths	23", 24", 29", and 30"
Max Lifting Capacity	250 lbs
Base Weight Without Top	72 lbs
Gauge of Steel	2mm
Speed	38mm/s
Standby Consumption	.2W
ACTIV PRO 2.0e Consumption	Max 350W and Max 5A
Decibel Rating	50db $\leq$
Total Stroke	650 mm
Power Cord	9' cord length with standard NEMA 3 prong plug
Finishes	Platinum, White, Black and Merle
ANSI BIFMA	X5.5
Green Certification	SCS Gold
UL	UL962
Warranty	10 years plus approved labor

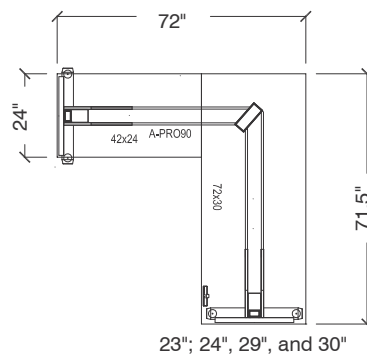
# Activ Pro 2.0 90 and 120 Degree Corner Desks



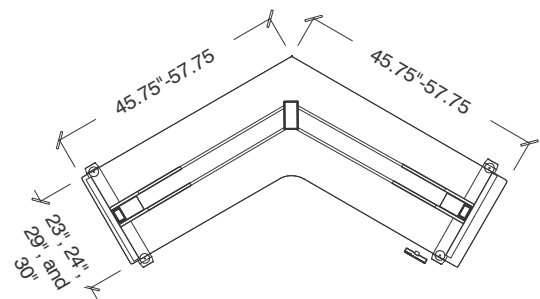
## Worksurface Sizes



90° — minimum



90° — maximum



120°

# Activ Pro 2.0 90 and 120 Degree Specifications

Handset	Push button with 4 programmable settings
Safety	Anti-collision
Foot Length in Inches	23.5" and 27.5" available for 23/24" and 29/30" deep worksurfaces
Leg Stage	3 stage
Leg Diameter	2.75" x 2.75"
Height Range (excluding top)	21.6" - 47.7"
Height Range (including top)	22.6" - 48.7"
Frame Width Expansion	120°: 470mm / 90°: 500mm
Worksurface Widths	48", 52", 54", 58", 60", 64", 66", 70", and 72"
Worksurface Depths	23", 24", 29", and 30"
Return width	23", 24", 29", 30", 35", 36", 41", 42", 47", and 48"
Max Lifting Capacity	300 lbs
Gauge of Steel	Inner/Middle tubes: 2mm / Outer tube 2mm
Base Weight Without Top	113 lbs
Speed	38mm/s
Standby Consumption	0.2W
Active Consumption	Max 500W and Max 13.5A
Decibel Rating	50db $\leq$
Total Stroke	650 mm
Power Cord	9' cord length with standard NEMA 3 prong plug
Finishes	Platinum, White, Black and Merle
ANSI BIFMA	X5.5
Green Certification	SCS Gold
UL	UL962
Warranty	10 years plus approved labor

# ACTIV Pro 2.0 2 Stage Desk



Tip: Illustration above shows desk with T-legs.

Tip: Only single and dual flat panel monitor arm applications are permitted for use with 2-leg height-adjustable desks.

Tip: Widths 66" and wider will automatically include a reinforcement channel to be installed underneath the worksurface.

Standard Includes	Required to Specify
<ul style="list-style-type: none"> <li>• Electric height-adjustable base:                             <ul style="list-style-type: none"> <li>– Black</li> <li>– Merle</li> <li>– Platinum</li> <li>– White</li> </ul> </li> <li>• Cable management tray</li> <li>• Laminate worksurface</li> <li>• Power cord: 9'</li> <li>• 4-preset switch</li> <li>• 1/2" glide adjustment</li> <li>• Attachment hardware</li> </ul>	<ol style="list-style-type: none"> <li>1 Style number</li> <li>2 Low-Pressure Laminate color number for worksurface</li> <li>3 Paint color number for base</li> <li>4 Options, if selected (see below)</li> </ol> <p>▶ See <i>Surface Materials</i>, page 506.</p>

Options	U.S. Price	Required to Specify
<b>Leg Type</b> <ul style="list-style-type: none"> <li>• C-leg</li> <li>• T-leg</li> </ul>	No cost No cost	Specify with C-leg. Specify with T-leg.
<b>Casters or Glides</b> <ul style="list-style-type: none"> <li>• Glides</li> <li>• Casters</li> </ul>	No cost +\$184	Specify with glides. Specify with casters.

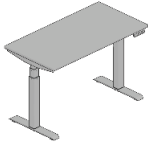
Specification Information		U.S. Base Prices										
Style Number	Dimensions Depth	Width										
		46"W	48"W	52"W	54"W	58"W	60"W	64"W	66"W	70"W	72"W	
APS2	23" or 24"	\$1257	\$1268	\$1294	\$1306	\$1332	\$1344	\$1370	\$1382	\$1408	\$1420	
	29" or 30"	\$1298	\$1309	\$1336	\$1347	\$1374	\$1385	\$1412	\$1423	\$1450	\$1461	



**For Canadian Pricing**  
Multiply U.S. Price by the Canadian price factor.  
▶ See page 1 for details.

# ACTIV Pro 2.0 3 Stage Desk

ACTIV Pro 2.0  
3 Stage Desk



Tip: Illustration above shows desk with T-legs.

Tip: Only single and dual flat panel monitor arm applications are permitted for use with 2-leg height-adjustable desks.

Tip: 3 stage base supports a maximum distributed weight capacity of 250 pounds. When calculating lifting capacity, subtract the weight of the worksurface.

Tip: Widths 66" and wider will automatically include a reinforcement channel to be installed underneath the worksurface.

Standard Includes	Required to Specify
<ul style="list-style-type: none"> <li>Electric height-adjustable base:                             <ul style="list-style-type: none"> <li>– Black</li> <li>– Merle</li> <li>– Platinum</li> <li>– White</li> </ul> </li> <li>Cable management tray</li> <li>Laminate worksurface</li> <li>Power cord: 9'</li> <li>4-preset switch</li> <li>1/2" glide adjustment</li> <li>Attachment hardware</li> </ul>	<ol style="list-style-type: none"> <li>Style number</li> <li>Low-Pressure Laminate color number for worksurface</li> <li>Paint color number for base</li> <li>Options, if selected (see below)</li> </ol> <p>▶ See <i>Surface Materials</i>, page 506.</p>

Options	U.S. Price	Required to Specify
<b>Leg</b>		
• C-leg	No cost	Specify with C-leg.
• T-leg	No cost	Specify with T-leg.
<b>Casters or Glides</b>		
• Glides	No cost	Specify with glides.
• Casters	+\$184	Specify with casters.

Specification Information		U.S. Base Prices									
Style Number	Dimensions Depth	Width									
		46"W	48"W	52"W	54"W	58"W	60"W	64"W	66"W	70"W	72"W
APS3	23" or 24"	\$1387	\$1399	\$1425	\$1437	\$1463	\$1475	\$1501	\$1513	\$1539	\$1551
	29" or 30"	\$1428	\$1440	\$1466	\$1478	\$1504	\$1516	\$1542	\$1554	\$1580	\$1592

 **For Canadian Pricing**  
Multiply U.S. Price by the Canadian price factor.  
▶ See page 1 for details.

# ACTIV Pro 2.0 2 Stage Base



Tip: Illustration above shows desk with T-legs.

Tip: Only single and dual flat panel monitor arm applications are permitted for use with 2-leg height-adjustable desks.

Standard Includes	Required to Specify
<ul style="list-style-type: none"> <li>• Electric height-adjustable base:                             <ul style="list-style-type: none"> <li>– Black</li> <li>– Merle</li> <li>– Platinum</li> <li>– White</li> </ul> </li> <li>• Cable management tray</li> <li>• 4-preset switch</li> <li>• Power cord: 9'</li> <li>• 1/2" glide adjustment</li> <li>• Attachment hardware</li> </ul>	<ul style="list-style-type: none"> <li>1 Style number</li> <li>2 Paint color number for base</li> <li>3 Options, if selected (see below)</li> <li>▶ See <i>Surface Materials</i>, page 506.</li> </ul>

	Options	U.S. Price	Required to Specify
<b>Leg</b>	• C-leg	No cost	Specify <i>with C-leg</i> .
	• T-leg	No cost	Specify <i>with T-leg</i> .
<b>Casters or Glides</b>	• Glides	No cost	Specify <i>with glides</i> .
	• Casters	+\$184	Specify <i>with casters</i> .

Specification Information		
Style Number	Depth	U.S. Base Price
<b>APS2B</b>	23" or 24"	\$1039
	29" or 30"	\$1039



**For Canadian Pricing**  
 Multiply U.S. Price by the Canadian price factor.  
 ▶ See page 1 for details.

# ACTIV Pro 2.0 3 Stage Base

ACTIV Pro 2.0  
3 Stage Base



Tip: Illustration above shows desk with T-legs.

Tip: Only single and dual flat panel monitor arm applications are permitted for use with 2-leg height-adjustable desks.

Tip: 3 stage base supports a maximum distributed weight capacity of 250 pounds. When calculating lifting capacity, subtract the weight of the worksurface.

Standard Includes	Required to Specify
<ul style="list-style-type: none"> <li>Electric height-adjustable base:                             <ul style="list-style-type: none"> <li>– Black</li> <li>– Merle</li> <li>– Platinum</li> <li>– White</li> </ul> </li> <li>Cable management tray</li> <li>4-preset switch</li> <li>Power cord: 9'</li> <li>1/2" glide adjustment</li> <li>Attachment hardware</li> </ul>	<ul style="list-style-type: none"> <li>1 Style number</li> <li>2 Paint color number for base</li> <li>3 Options, if selected (see below)</li> <li>▶ See <i>Surface Materials</i>, page 506.</li> </ul>

Options	U.S. Price	Required to Specify
<b>Leg</b> <ul style="list-style-type: none"> <li>C-leg</li> <li>T-leg</li> </ul>	No cost No cost	Specify with C-leg. Specify with T-leg.
<b>Casters or Glides</b> <ul style="list-style-type: none"> <li>Glides</li> <li>Casters</li> </ul>	No cost +\$184	Specify with glides. Specify with casters.

Specification Information		
Style Number	Depth	U.S. Base Price
APS3B	23" or 24"	\$1175
	29" or 30"	\$1175

ACTIV PRO 2.0

 **For Canadian Pricing**  
 Multiply U.S. Price by the Canadian price factor.  
 ▶ See page 1 for details.

# ACTIV Pro 2.0 90° Desk



Tip: The largest desk size is 72" x 72".

Tip: Base supports a maximum distributed weight capacity of 300 pounds. When calculating lifting capacity, subtract the weight of the worksurface.

Tip: All return depths are 24". The depths indicated at the bottom of "return width" indicate desk depths that include an extra stretcher bar needed for certain configurations.

Tip: Widths 66" and wider will automatically include a reinforcement channel to be installed underneath the worksurface.

Standard Includes	Required to Specify
-------------------	---------------------

- Worksurface: Low-Pressure Laminate
- Return depth: 24"
- Electric height-adjustable T-leg base paint:
  - Black
  - Merle
  - Platinum
  - White
- 4-preset switch
- Power cord: 9'
- Two cable management trays
- 1/2" glide adjustment
- Attachment hardware

- 1 Style number
  - 2 Low-Pressure Laminate color number for worksurface
  - 3 Paint color number for base
  - 4 Options, if selected (see below)
- ▶ See *Surface Materials*, page 506.

Options	U.S. Price	Required to Specify
---------	------------	---------------------

<b>Leg</b>	• C-leg	No cost	Specify with C-leg.
	• T-leg	No cost	Specify with T-leg.
<b>Casters or Glides</b>	• Glides	No cost	Specify with glides.
	• Casters	+\$184	Specify with casters.

### Specification Information

• Style Number	• Dimensions Depth	• U.S. Base Prices Width									
		48"W	52"W	54"W	58"W	60"W	64"W	66"W	70"W	72"W	

#### With 23"W or 24"W Return

<b>APS390</b>	23" or 24"	\$2483	\$2510	\$2521	\$2540	\$2554	\$2579	\$2695	\$2720	\$2734
	29" or 30"	\$2534	\$2559	\$2573	\$2584	\$2590	\$2622	\$2739	\$2764	\$2770

#### With 29"W or 30"W Return

<b>APS390</b>	23" or 24"	\$2494	\$2521	\$2532	\$2551	\$2565	\$2590	\$2706	\$2731	\$2745
	29" or 30"	\$2545	\$2570	\$2584	\$2595	\$2602	\$2633	\$2750	\$2775	\$2782

#### With 35"W Return

<b>APS390</b>	23" or 24"	\$2502	\$2529	\$2540	\$2559	\$2573	\$2598	\$2714	\$2739	\$2753
	29"	\$2553	\$2578	\$2592	\$2603	\$2610	\$2641	\$2758	\$2783	\$2790
	30"	\$2657	\$2682	\$2696	\$2707	\$2714	\$2745	\$2863	\$2888	\$2895

#### With 36"W Return

<b>APS390</b>	23" or 24"	\$2502	\$2529	\$2540	\$2559	\$2573	\$2598	\$2714	\$2739	\$2753
	29" or 30"	\$2657	\$2682	\$2696	\$2707	\$2714	\$2745	\$2863	\$2888	\$2895

▶ **Specification Information, continued on next page**



**For Canadian Pricing**  
 Multiply U.S. Price by the Canadian price factor.  
 ▶ See page 1 for details.

► **Specification Information, continued from previous page**

**Specification Information**

Style Number	Dimensions Depth	U.S. Base Prices								
		Width								
		48"W	52"W	54"W	58"W	60"W	64"W	66"W	70"W	72"W

**With 41"W Return**

<b>APS390</b>	23"	\$2507	\$2534	\$2545	\$2564	\$2578	\$2603	\$2719	\$2744	\$2758
	24"	\$2611	\$2638	\$2649	\$2668	\$2682	\$2707	\$2824	\$2849	\$2863
	29" or 30"	\$2662	\$2687	\$2649	\$2712	\$2719	\$2750	\$2868	\$2893	\$2900

**With 42"W Return**

<b>APS390</b>	23" or 24"	\$2611	\$2638	\$2649	\$2668	\$2682	\$2707	\$2824	\$2849	\$2863
	29" or 30"	\$2662	\$2687	\$2701	\$2712	\$2719	\$2750	\$2868	\$2893	\$2900

**With 47"W or 48"W Return**

<b>APS390</b>	23" or 24"	\$2617	\$2644	\$2655	\$2674	\$2688	\$2713	\$2830	\$2855	\$2869
	29" or 30"	N.A.	N.A.	N.A.	N.A.	N.A.	N.A.	N.A.	N.A.	N.A.



*Tip: Widths 66" and wider will automatically include a reinforcement channel to be installed underneath the worksurface.*

 **For Canadian Pricing**  
 Multiply U.S. Price by the Canadian price factor.  
 ► See page 1 for details.

# ACTIV Pro 2.0 120° Desk



Standard Includes	Required to Specify
-------------------	---------------------

- Electric height-adjustable base:
  - Black
  - Merle
  - Platinum
  - White
- T-leg
- 4-preset switch
- Power cord: 9'
- Two cable management trays
- 1/2" glide adjustment
- Attachment hardware
- Laminate worksurface

- 1 Style number
  - 2 Low-Pressure Laminate color number for worksurface
  - 3 Paint color number for base
- ▶ See *Surface Materials*, page 506.

Specification Information		
• Style Number	• Depth	• U.S. Price
<b>APS3120</b>	23"	\$2901
	24"	\$2901
	29"	\$3318
	30"	\$3318



**For Canadian Pricing**  
 Multiply U.S. Price by the Canadian price factor.  
 ▶ See page 1 for details.

# ACTIV 2.0 3-Leg Base, 90° and 120° Base

ACTIV 2.0 3-Leg Base,  
90° and 120° Base



*Tip: Extended stretcher bars are recommended for any width 65" and larger. Short stretcher bars are included and are recommended for worksurfaces 48"-65"W.*

*Tip: For worksurfaces 65"W and larger, extended stretcher bars are recommended to maximize knee clearance and usable work-surface space.*

*Tip: 3-leg bases can be designed with up to 8" of overhang.*

## Standard Includes

- Electric height-adjustable base:
  - Black
  - Merle
  - Platinum
  - White
- 4-preset switch
- Power cord: 9'
- Two cable management trays
- 1/2" glide adjustment
- Attachment hardware

## Required to Specify

- 1 Style number
- 2 Paint color number for base
- ▶ See *Surface Materials*, page 506.

## Specification Information

Style Number	Depth	U.S. Price
<b>APS3L3B</b>	23"	\$1988
	24"	\$1988
	29"	\$1988
	30"	\$1988
:	:	:



### For Canadian Pricing

Multiply U.S. Price by the Canadian price factor.

▶ See page 1 for details.

# ACTIV Accessories

## ACTIV 2.0 Extended Stretcher Bar



Tip: Two stretcher bars are included in a box.

Tip: One style number is needed per side longer than 65".

Standard Includes		Required to Specify	
<ul style="list-style-type: none"> <li>Stretcher bar, quantity two: paint</li> </ul>		<ul style="list-style-type: none"> <li>1 Style number</li> <li>2 Paint color number for bar</li> <li>▶ See <i>Surface Materials</i>, page 506.</li> </ul>	
Specification Information			
Style Number	U.S. Price		
APS3STRETCHER	\$104		

## ACTIV Casters — Set of Four



Standard Includes		Required to Specify	
<ul style="list-style-type: none"> <li>Castors: two locking, two non-locking</li> </ul>		<ul style="list-style-type: none"> <li>Style number</li> </ul>	
Specification Information			
Style Number	U.S. Price		
ACTIV-CASTORS	\$184		

## ACTIV Worksurface



Tip: Can be used with the ACTIV Pro 2.0 2-leg base.

Standard Includes		Required to Specify									
<ul style="list-style-type: none"> <li>Worksurface: Low-Pressure Laminate</li> </ul>		<ul style="list-style-type: none"> <li>1 Style number</li> <li>2 Low-Pressure Laminate number for worksurface</li> <li>▶ See <i>Surface Materials</i>, page 506.</li> </ul>									
Specification Information											
Style Number	Dimensions Height	U.S. Base Prices Width									
		46"W	48"W	52"W	54"W	58"W	60"W	64"W	66"W	70"W	72"W
ACTVWORKSURFACE	23"/24"	\$280	\$291	\$318	\$329	\$356	\$367	\$394	\$405	\$431	\$443
	29"/30"	\$329	\$342	\$367	\$380	\$406	\$418	\$444	\$456	\$482	\$494



**For Canadian Pricing**  
 Multiply U.S. Price by the Canadian price factor.  
 ▶ See page 1 for details.

## ACTIV Return Worksurface



Tip: Can be used with the ACTIV Pro 2.0 3-leg 90° base.

Standard Includes	Required to Specify
-------------------	---------------------

- Worksurface: Low-Pressure Laminate

- 1 Style number
- 2 Low-Pressure Laminate number for worksurface
- ▶ See *Surface Materials*, page 506.

Specification Information		U.S. Prices				
Style Number	Dimensions Depth	Width				
		24"W	30"W	36"W	42"W	48"W
<b>ACTVRETURNWKSF</b>	24"	\$204	\$215	\$223	\$228	\$234

## ACTIV 120° Worksurface



Tip: Can be used with the ACTIV Pro 2.0 3-leg 120° base.

Standard Includes	Required to Specify
-------------------	---------------------

- Worksurface: Low-Pressure Laminate

- 1 Style number
- 2 Low-Pressure Laminate number for worksurface
- ▶ See *Surface Materials*, page 506.

Specification Information		U.S. Price
Style Number	Depth	Price
<b>ACTVWORKSURF120</b>	24"	\$ 913
	30"	\$1330

ACTIV PRO 2.0

 **For Canadian Pricing**  
 Multiply U.S. Price by the Canadian price factor.  
 ▶ See page 1 for details.



---

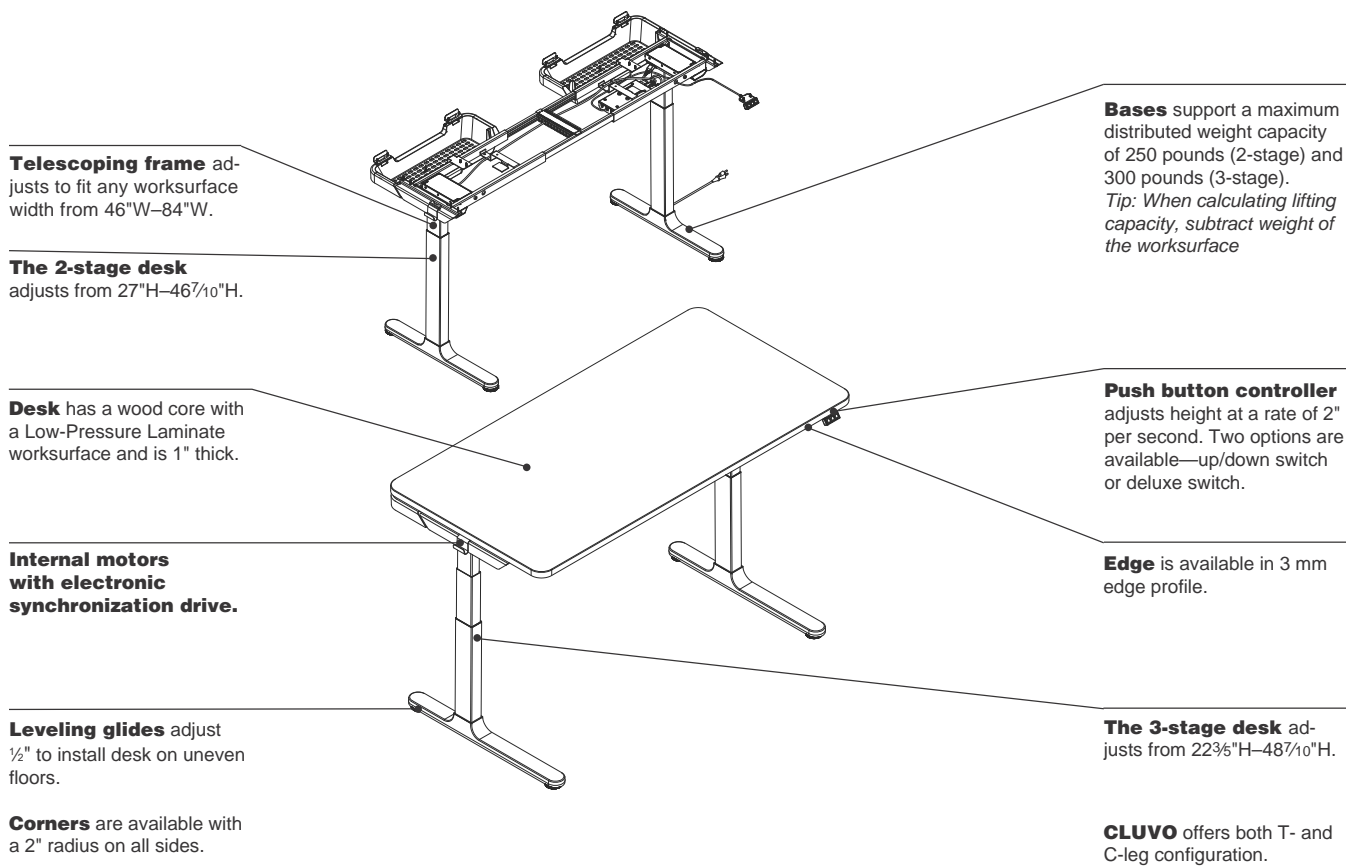
# CLUVO

<b>Understanding</b>	<b>80</b>
<b>Specifying</b>	<b>86</b>

# CLUVO Height-Adjustable Desks and Bases

CLUVO supports wellbeing at work by allowing users to move between seated and standing postures throughout the workday.

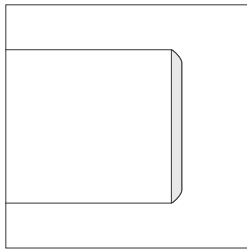
► Specifying, page 86



## Product Details

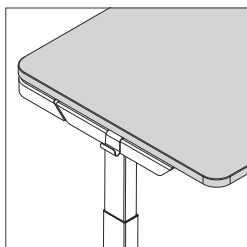
### Low-Pressure Laminate

**Front (user's) edge profile** is available in 3 mm edge profile.



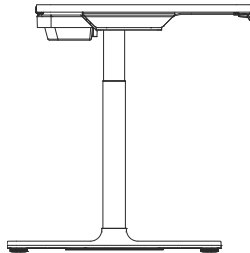
**PVC-free, 3 mm edge profiles with matching 1 mm side and back edges** are also PVC-free. ▶ See *Surface Materials* in this book for specific PVC-free availability, page 505.

**Edge profile finishes** always match laminate finishes.

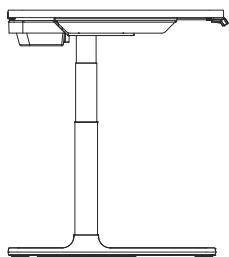


**Radius corners** are standard with a 2" radius on all four sides.

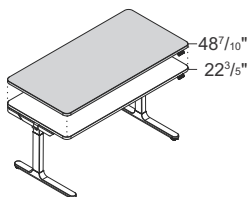
**Overhang** is available. The maximum overhang available as a standard option is 15"W.



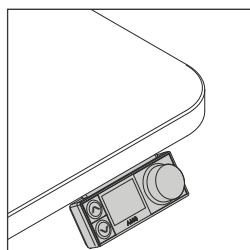
**T-leg configuration** is available on CLUVO in 29"/30" depth worksurface options.



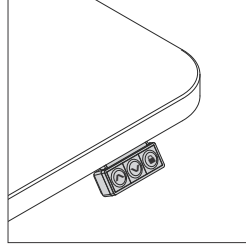
**C-leg configuration** is available on CLUVO in 24" and 29"/30" depth worksurface options.



**CLUVO 3-stage desk** adjusts from 22<sup>2</sup>/<sub>5</sub>"H–48<sup>7</sup>/<sub>10</sub>"H, while the 2-stage desk adjusts from 27"H–46<sup>7</sup>/<sub>10</sub>"H in any increment.



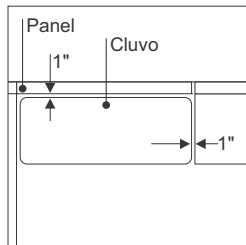
**Deluxe switch** includes the ability to personalize the LED display, allows users to set seated and standing heights, and set reminders to change postures.



**Up/down controller** is available as an option and easily adjusts height of desk, at a rate of 2" per second, by simply pushing the up and down arrows.

**Obstruction sensing technology** is standard with all CLUVO desks. The worksurface will backtrack when it makes contact with an object.

**Casters** are available as an option on CLUVO. The front two casters lock while the back two casters do not.



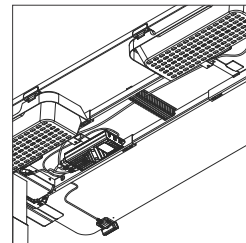
**Rectangle desk sizes** are listed in actual dimensions to allow for 1" gap to adjacent furniture eliminating any pinch points.

## Wiring and Cabling

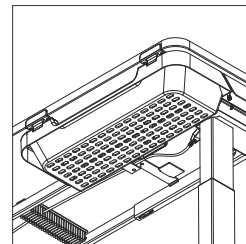
**Electric motor with whisper quiet operation** adjusts at 2" per second. Motor is 24V DC and includes a 9' power cord. Motor for 2-leg desk has a 0.2W standby power.

**CLUVO desks and bases** are listed by ETL. ▶ See page 84

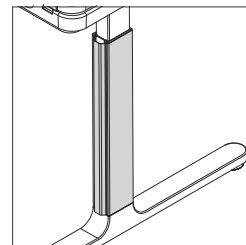
**Power and data strips** are field-installed on worksurface. Specify appropriate attachment bracket depending on application. ▶ See page 139 for *Work Tools*.



**Cable management** includes a simple organizer to manage desk cables.



**Cable baskets**, available as an option or ordered separately, support cable management below the worksurface.



**Leg sleeves**, available as an option, help route the power cords down to the floor and provide additional finish options.

**Controller** can be mounted on either the left- or right-hand side of the top and is field installed.

## Surface Materials

### Low-Pressure Laminate Desk

24L0	Graphite Walnut
25L5	Virginia Walnut
25L8	Clear Walnut
26L1	Natural Cherry
2L09	Clear Maple
2L30	Arctic White
2L83	Seagull
2L84	Milk White
2LAW	Ash Wenge
2LCN	Clay Noce
2LCW	Clay Wenge
2LAK	Clear Oak
2LAT	Acacia

**3 mm edge profile**

- Plastic

### Height-adjustable base

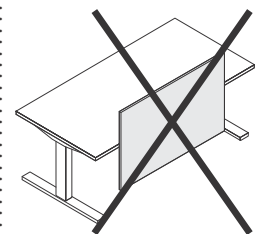
- F1 Platinum
- F2 White

### Feet and leg sleeves

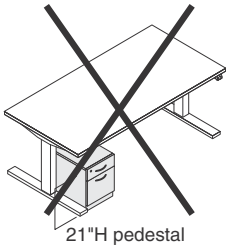
- F1 Platinum
- F2 White
- F4 Merle
- F9 Burnished Bronze
- F10 Brass

## Application Topics

**Moving desks** can collide with other components. Do not install overhead storage, desk-height power, or desk accessories in the path of height-adjustable desks.

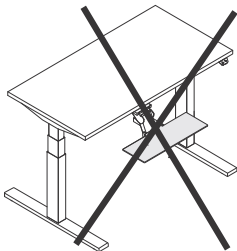


**Universal boundary screens** are not permitted on height-adjustable desks, as they do not pass minimum safety requirements which could result in the desk tipping over.

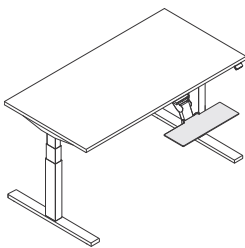


**On extended height desks**, any storage higher than 18<sup>3</sup>/<sub>10</sub>" will impede height range of desk. On basic height desks, any storage higher than 24" will impede the height range of the desk.

**All assemblies** meet or exceed ANSI/BIFMA standards.



**Keyboard assemblies** are not allowed on 23"D or smaller than 46"W height-adjustable desks. They do not meet minimum safety requirements.



**Steelcase keyboard assemblies** can be installed on 29"/30"D. Specify with an 11" track.

**WARNING**

Read base only warranty limitations.

**Installation**

**Height-adjustable base** requires attachment to the worksurface.

**Base** supports a maximum of distributed weight capacity of 250 pounds (2-stage) and 300 pounds (3-stage).



# CLUVO 2-Stage Specifications

Handset	Up/down switch with lock or deluxe switch with LED
Safety	Obstruction detection technology
Foot Length in Inches	24" foot for 24"D top 30" foot for 29"D and 30"D tops
Legs	2 stage, available with T or C Leg
Leg Diameter	1.9" x 3.15"
Height Range (excluding top)	26"–45.7"
Height Range (including top)	27"–46.7"
Frame Width Expansion	Width extendable 46"–84" in 1mm increments
Worksurface Widths	46", 48", 52", 54", 58", 60", 64", 66", 70", 72", 76", and 84"
Worksurface Depths	24", 29", and 30"
Max Lifting Capacity	250 lbs
Base Weight Without Top	66 lbs
Gauge of Steel	2mm for inner tube and 1.5mm for outer tube
Speed	2" per second
Standby Consumption	.2W
Consumption	Max 350W and Max 5A
Decibel Rating	50db $\leq$
Total Stroke	500 mm
Power Cord	9' cord length with standard NEMA 3 prong plug
Finishes	Platinum, White, Merle, Burnished Bronze, and Brass
ANSI BIFMA	X5.5
Green Certification	SCS Gold
UL	UL962
Warranty	10 years plus approved labor

# CLUVO 3-Stage Specifications

Handset	Up/down switch with lock or deluxe switch with LED
Safety	Obstruction detection technology
Foot Length in Inches	24" foot for 24"D top 30" foot for 29"D and 30"D tops
Legs	3 stage, available with T or C Leg
Leg Diameter	1.9" x 3.15"
Height Range (excluding top)	21.6"–47.7"
Height Range (including top)	22.6"–48.7"
Frame Width Expansion	Width extendable 46"–84" in 1mm increments
Worksurface Widths	46", 48", 52", 54", 58", 60", 64", 66", 70", 72", 76", and 84"
Worksurface Depths	24", 29", and 30"
Max Lifting Capacity	300 lbs
Base Weight Without Top	72 lbs
Gauge of Steel	2mm
Speed	2" per second
Standby Consumption	.2W
Consumption	Max 350W and Max 5A
Decibel Rating	50db≤
Total Stroke	650 mm
Power Cord	9' cord length with standard NEMA 3 prong plug
Finishes	Platinum, White, Black, Merle, Burnished Bronze, and Brass
ANSI BIFMA	X5.5
Green Certification	SCS Gold
UL	UL962
Warranty	10 years plus approved labor

# CLUVO Desk

Tip: Illustration above shows desk with T-legs.

Tip: Only single and dual flat panel monitor arm applications are permitted for use with 2-leg height-adjustable desks.

Tip: 2 stage base supports a maximum distributed weight capacity of 250 pounds (300 for 3 stage). When calculating lifting capacity, subtract the weight of the worksurface.



Standard Includes	Required to Specify
<ul style="list-style-type: none"> <li>Electric height-adjustable base:                             <ul style="list-style-type: none"> <li>– Platinum</li> <li>– White</li> </ul> </li> <li>Foot: paint</li> <li>Power cord: 9'</li> <li>Laminate worksurface with radius corners</li> <li>Up/down switch</li> <li>1/2" glide adjustment</li> <li>Attachment hardware</li> </ul>	<ol style="list-style-type: none"> <li>Style number</li> <li>Laminate color number for worksurface</li> <li>Paint color number for base</li> <li>Paint color number for foot</li> <li>Options, if selected (see below)</li> </ol> <p>▶ See <i>Surface Materials</i>, page 506.</p>

Options	U.S. Price	Required to Specify
<b>Leg</b> <ul style="list-style-type: none"> <li>C-leg</li> <li>T-leg</li> </ul>	No cost No cost	Specify <i>with C-leg</i> . Specify <i>with T-leg</i> .
<b>Hand Set</b> <ul style="list-style-type: none"> <li>Up/down</li> <li>Deluxe</li> </ul>	No cost +\$100	Specify <i>with up/down hand set</i> . Specify <i>with deluxe hand set</i> .
<b>Leg Sleeve</b> <ul style="list-style-type: none"> <li>No leg sleeve</li> <li>With leg sleeve</li> </ul>	No cost +\$100	Specify <i>with no leg sleeve</i> . Specify <i>with leg sleeve</i> .
<b>Leg Sleeve Finish</b> <ul style="list-style-type: none"> <li>Paint</li> </ul>	No cost	Specify paint color number.
<b>Cable Baskets</b> <ul style="list-style-type: none"> <li>No cable basket</li> <li>With cable baskets</li> </ul>	No cost +\$158	Specify <i>with no cable basket</i> . Specify <i>with cable baskets</i> .
<b>Casters or Glides</b> <ul style="list-style-type: none"> <li>Glides</li> <li>Casters</li> </ul>	No cost +\$184	Specify <i>with glides</i> . Specify <i>with casters</i> .

Specification Information		U.S. Base Prices											
Style Number	Dimensions Depth	Width											
		46"W	48"W	52"W	54"W	58"W	60"W	64"W	66"W	70"W	72"W	76"W	84"W

## CLUVO Desk, 2 Stage

CLS2	24"	\$1603	\$1613	\$1639	\$1650	\$1676	\$1687	\$1713	\$1724	\$1750	\$1761	\$1787	\$1835
	29" or 30"	\$1639	\$1650	\$1676	\$1687	\$1713	\$1724	\$1750	\$1761	\$1787	\$1798	\$1824	\$1872

## CLUVO Desk, 3 Stage

CLS3	24"	\$1769	\$1780	\$1806	\$1817	\$1843	\$1854	\$1880	\$1891	\$1917	\$1927	\$1954	\$2001
	29" or 30"	\$1806	\$1817	\$1843	\$1854	\$1880	\$1891	\$1917	\$1927	\$1954	\$1964	\$1991	\$2038

 **For Canadian Pricing**  
Multiply U.S. Price by the Canadian price factor.  
▶ See page 1 for details.

Tip: Illustration above shows desk with T-legs.

Tip: Only single and dual flat panel monitor arm applications are permitted for use with 2-leg height-adjustable desks.

Tip: 2 stage base supports a maximum distributed weight capacity of 250 pounds (300 for 3 stage). When calculating lifting capacity, subtract the weight of the worksurface.

Standard Includes	Required to Specify
-------------------	---------------------

- Electric height-adjustable base:
  - Platinum
  - White
- Foot: paint
- Up/down switch
- 1/2" glide adjustment
- Power cord: 9'
- Attachment hardware

- 1 Style number
  - 2 Paint color number for base
  - 3 Paint color number for foot
  - 4 Options, if selected (see below)
- ▶ See *Surface Materials*, page 506.

Options	U.S. Price	Required to Specify
---------	------------	---------------------

<b>Leg</b>	<ul style="list-style-type: none"> <li>• C-leg</li> <li>• T-leg</li> </ul>	No cost No cost	Specify with <i>C-leg</i> . Specify with <i>T-leg</i> .
<b>Hand Set</b>	<ul style="list-style-type: none"> <li>• Up/down</li> <li>• Deluxe</li> </ul>	No cost +\$100	Specify with <i>up/down hand set</i> . Specify with <i>deluxe hand set</i> .
<b>Leg Sleeve</b>	<ul style="list-style-type: none"> <li>• No leg sleeve</li> <li>• With leg sleeve</li> </ul>	No cost +\$100	Specify with <i>no leg sleeve</i> . Specify with <i>leg sleeve</i> .
<b>Leg Sleeve Finish</b>	<ul style="list-style-type: none"> <li>• Paint</li> </ul>	No cost	Specify paint color number.
<b>Cable Baskets</b>	<ul style="list-style-type: none"> <li>• No cable basket</li> <li>• With cable baskets</li> </ul>	No cost +\$158	Specify with <i>no cable basket</i> . Specify with <i>cable baskets</i> .
<b>Casters or Glides</b>	<ul style="list-style-type: none"> <li>• Glides</li> <li>• Casters</li> </ul>	No cost +\$184	Specify with <i>glides</i> . Specify with <i>casters</i> .

Specification Information		
Style Number	Depth	U.S. Base Price


### CLUVO Base, 2 Stage

<b>CLS2B</b>	24"	\$1329
	29" or 30"	\$1329

### CLUVO Base, 3 Stage

<b>CLS3B</b>	24"	\$1496
	29" or 30"	\$1496



 **For Canadian Pricing**  
Multiply U.S. Price by the Canadian price factor.  
▶ See page 1 for details.

# CLUVO Accessories

## Cable Basket, Set of Two



Standard Includes		Required to Specify
<ul style="list-style-type: none"> <li>Set of two cable bases (F1 Platinum)</li> <li>Install hardware</li> </ul>		Style number
Specification Information		
Style Number	U.S. Price	
CLCBASKET	\$158	

## Set of Four Casters



Standard Includes		Required to Specify
<ul style="list-style-type: none"> <li>Casters: two locking, two non-locking</li> </ul>		Style number
Specification Information		
Style Number	U.S. Price	
CLCASTERS	\$184	



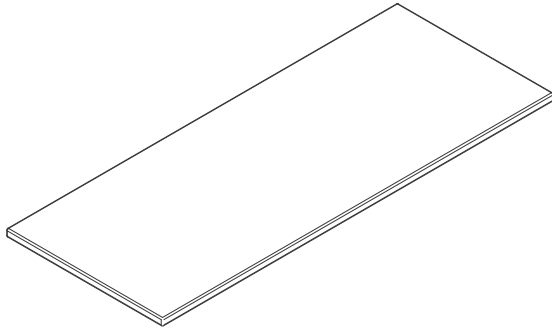
**For Canadian Pricing**  
 Multiply U.S. Price by the Canadian price factor.  
 ▶ See page 1 for details.

---

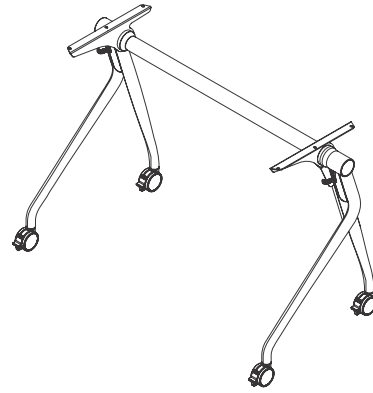
# CONCUR

<b>Understanding</b>	<b>90</b>
<b>Specifying</b>	<b>92</b>

# Statement of Line



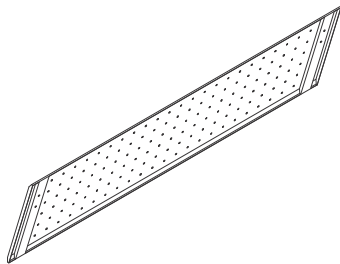
Worksurface



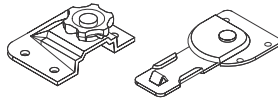
Frame Assembly

---

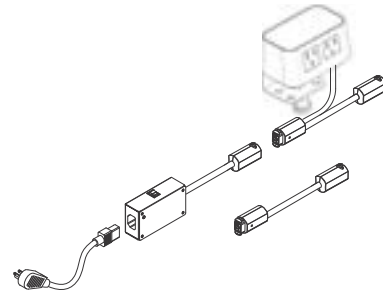
## Optional



Modesty Panel



Ganging Kit



Power

# Concur Specifications



Frame width	47.25", 59.05" and 70.85"
Width between front legs	44.5", 56.25" and 68.1"
Width between rear legs	40.75", 52.5" and 64.35"
Leg Depth	21"
Cantilever Depth	13.75"
Height (excluding top)	28.5"
Worksurface widths	48", 60" and 72"
Worksurface depths	24"
Worksurface thickness	1"
Modesty Panel	Steel
Modesty Panel Width	39.5", 51.25" and 63.1"
Modesty Panel Height	14"
Clearance between Modesty Panel and Floor	12"
Castors	Soft, Locking
Weight Capacity	200 lbs
Frame weight without top	27 lbs
24" Depth x 48" Wide Worksurface Weight	40 lbs
24" Depth x 60" Wide Worksurface Weight	50 lbs
24" Depth x 72" Wide Worksurface Weight	60 lbs
Power in-feed length	72"
Power Box	2 electrical outlets with worksurface clamp
Certifications	BIFMAX5.5-2014
Electrical Compliance	ETL Listed, UL Recognized

# CONCUR Table



Standard Includes	Required to Specify
<ul style="list-style-type: none"> <li>• Top: Low-Pressure Laminate</li> <li>• Frame: paint</li> <li>• Square edge: 3 mm plastic edge band</li> <li>• Steel legs with locking casters</li> </ul>	<ol style="list-style-type: none"> <li>1 Style number</li> <li>2 Low-Pressure Laminate color number for top</li> <li>3 Paint color number for frame</li> <li>4 Options, if selected (see below)</li> </ol> <p>▶ See <i>Surface Materials</i>, page 506.</p>

	Options	U.S. Price	Required to Specify
<b>Modesty Panel</b>	<ul style="list-style-type: none"> <li>• 48"W</li> <li>• 60"W</li> <li>• 72"W</li> </ul>	<ul style="list-style-type: none"> <li>+\$269</li> <li>+\$296</li> <li>+\$323</li> </ul>	<ul style="list-style-type: none"> <li>Specify with 48"W modesty panel.</li> <li>Specify with 60"W modesty panel.</li> <li>Specify with 72"W modesty panel.</li> </ul>

Specification Information				
Style Number	Dimensions Depth	U.S. Base Prices		
		Width		
		48"W	60"W	72"W
<b>CNCRTABLE</b>	24"	\$1267	\$1381	\$1498



**For Canadian Pricing**  
 Multiply U.S. Price by the Canadian price factor.  
 ▶ See page 1 for details.



Standard Includes	Required to Specify
-------------------	---------------------

- Frame: paint
- Steel leg with locking casters

- 1 Style number
- 2 Paint color number for frame
- ▶ See *Surface Materials*, page 506.

Specification Information			
---------------------------	--	--	--

Style Number	U.S. Prices		
	Width		
	48"W	60"W	72"W
<b>CNCRFRAME</b>	\$967	\$1009	\$1048

 **For Canadian Pricing**  
 Multiply U.S. Price by the Canadian price factor.  
 ▶ See page 1 for details.

# CONCUR Frame and Two TIZU Nest Chairs Bundle



Tip: Bundle includes two TIZU nest chairs.

Standard Includes	Required to Specify
<ul style="list-style-type: none"> <li>Chairs: fabric</li> <li>Frame: paint</li> <li>Steel leg with locking casters</li> <li>Set of two TIZU nest chairs</li> </ul>	<ol style="list-style-type: none"> <li>Style number</li> <li>Paint color number for frame</li> <li>Fabric color number for chairs</li> <li>Options, if selected (see below)</li> </ol> <p>▶ See <i>Surface Materials</i>, page 506.</p>

Options	U.S. Price	Required to Specify
<b>Surface Materials</b> <b>Seat cover</b> <ul style="list-style-type: none"> <li>Fabric price group 1</li> <li>Fabric price group 2</li> <li>Vinyl price group 2</li> <li>Fabric price group 3</li> <li>Polyurethane</li> </ul>	No cost +\$ 38 +\$ 38 +\$ 78 +\$144	Specify fabric color number. Specify fabric color number. Specify vinyl color number. Specify fabric color number. Specify polyurethane color number.
<b>Packaging</b> <ul style="list-style-type: none"> <li>Knocked down</li> <li>Fully assembled</li> </ul>	No cost +\$196	Specify <i>with knocked down packaging</i> . Specify <i>with fully assembled packaging</i> .
<b>Casters or Glides</b> <ul style="list-style-type: none"> <li>Soft, 2-tone grey</li> <li>Soft, black</li> <li>Glides, black</li> </ul>	No cost No cost +\$128	Specify <i>with two tone grey soft casters</i> . Specify <i>with black soft casters</i> . Specify <i>with black glides</i> .

## Specification Information

Style Number	U.S. Base Prices
	<b>Width</b> 60"W : 72"W

Tip: Black frame only available with chrome base and soft, black casters or glides.

Tip: White frame only available with white or platinum base and soft, 2-tone grey casters or glides.

Tip: Armless option not available with plastic back.

### Bundle with Black Frame, Mesh Back, Armless, Chrome Base Chairs

<b>CNCRTIZUBNDL</b>	\$2121	\$2157
---------------------	--------	--------

### Bundle with White Frame, Mesh Back, Armless, Platinum Base Chairs

<b>CNCRTIZUBNDL</b>	\$2157	\$2194
---------------------	--------	--------

### Bundle with White Frame, Mesh Back, Armless, White Base Chairs

<b>CNCRTIZUBNDL</b>	\$2184	\$2221
---------------------	--------	--------

### Bundle with Black Frame, Plastic Back, Fixed Arms, Chrome Base Chairs

<b>CNCRTIZUBNDL</b>	\$2159	\$2197
---------------------	--------	--------

### Bundle with White Frame, Plastic Back, Fixed Arms, Platinum Base Chairs

<b>CNCRTIZUBNDL</b>	\$2198	\$2234
---------------------	--------	--------

### Bundle with White Frame, Plastic Back, Fixed Arms, White Base Chairs

<b>CNCRTIZUBNDL</b>	\$2224	\$2262
---------------------	--------	--------

### Bundle with Black Frame, Mesh Back, Fixed Arms, Chrome Base Chairs

<b>CNCRTIZUBNDL</b>	\$2207	\$2244
---------------------	--------	--------

### Bundle with White Frame, Mesh Back, Fixed Arms, Platinum Base Chairs

<b>CNCRTIZUBNDL</b>	\$2247	\$2279
---------------------	--------	--------

### Bundle with White Frame, Mesh Back, Fixed Arms, White Base Chairs

<b>CNCRTIZUBNDL</b>	\$2276	\$2308
---------------------	--------	--------

**For Canadian Pricing**  
 Multiply U.S. Price by the Canadian price factor.  
 ▶ See page 1 for details.

## CONCUR Power Base In-Feed with Control Box and 72" Cord



Standard Includes		Required to Specify
<ul style="list-style-type: none"> <li>Power infeed</li> </ul>		Style number
Specification Information		
Style Number	U.S. Price	
<b>CONCUR-EE-CB</b>	\$537	

## CONCUR 60" Power Link for Concur Training Table



*Tip: The limit for connected power links is eight units to prevent control box overload.*

Standard Includes		Required to Specify
<ul style="list-style-type: none"> <li>Power link</li> </ul>		Style number
Specification Information		
Style Number	U.S. Price	
<b>CONCUR-EE-CNT</b>	\$356	

## CONCUR 24" Power Jumper for Concur Training Table



*Tip: Jumpers are not required. Only specify jumpers if a distance needs to be spanned further than the power link power cords will stretch.*

Standard Includes		Required to Specify
<ul style="list-style-type: none"> <li>Power jumper</li> </ul>		Style number
Specification Information		
Style Number	U.S. Price	
<b>CONCUR-EE-JMP</b>	\$128	



**For Canadian Pricing**  
 Multiply U.S. Price by the Canadian price factor.  
 ▶ See page 1 for details.

## CONCUR Ganging Kit



*Tip: The ganging kit is designed to assist with consistent clean rows and layouts when planning with Concur.*

Standard Includes		Required to Specify
<ul style="list-style-type: none"> <li>Ganging kit and hardware</li> </ul>		Style number

Specification Information	
Style Number	U.S. Price
CONCUR-GK	\$49

## CONCUR Worksurface



Standard Includes		Required to Specify
<ul style="list-style-type: none"> <li>Worksurface: Low-Pressure Laminate</li> </ul>		1 Style number 2 Low-Pressure Laminate color number for worksurface ▶ See <i>Surface Materials</i> , page 506.

Specification Information				
Style Number	Dimensions Depth	U.S. Prices Width		
		48"W	60"W	72"W
CNCRWORKSURFACE	24"	\$300	\$372	\$450

## CONCUR Modesty Panel



Standard Includes		Required to Specify
<ul style="list-style-type: none"> <li>Steel modesty panel with attachment hardware</li> </ul>		Style number

Specification Information			
Style Number	U.S. Prices Width		
	48"W	60"W	72"W
CNCRMODESTY	\$269	\$296	\$323



**For Canadian Pricing**  
 Multiply U.S. Price by the Canadian price factor.  
 ▶ See page 1 for details.

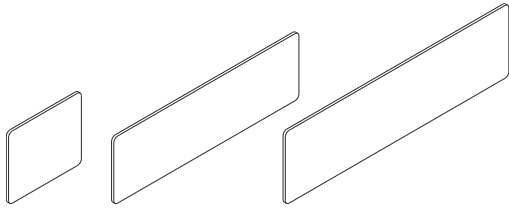
---

# 3F

<b>Understanding</b>	<b>98</b>
<b>Specifying</b>	<b>109</b>

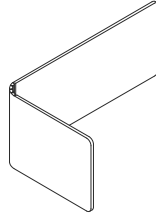
# Statement of Line

## 3F Screens



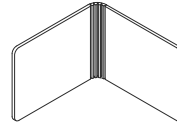
### Linear Screen

Understanding  
▶ Page 101  
Specifying  
▶ Page 111



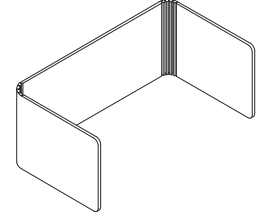
### Full Desk L-Screen

Understanding  
▶ Page 102  
Specifying  
▶ Page 112



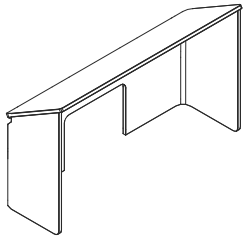
### Half Desk L-Screen

Understanding  
▶ Page 102  
Specifying  
▶ Page 113



### U-Screen

Understanding  
▶ Page 103  
Specifying  
▶ Page 114

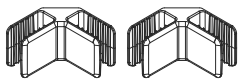


### Hooded Screen

Understanding  
▶ Page 104  
Specifying  
▶ Page 115

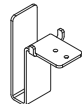
*Tip: Hanging panel mounting kits are specified separately.*

## Brackets



### Screen Corner Connector

Understanding  
▶ Page 108  
Specifying  
▶ Page 117



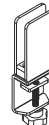
### Sleeve Bracket

Understanding  
▶ Page 108  
Specifying  
▶ Page 117



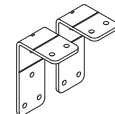
### Top Mounted Bracket

Understanding  
▶ Page 108  
Specifying  
▶ Page 117



### Top Mounted Bracket Clamp

Understanding  
▶ Page 108  
Specifying  
▶ Page 118



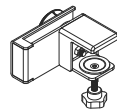
### Modesty and Privacy L-Bracket

Understanding  
▶ Page 108  
Specifying  
▶ Page 118



### Fixed Privacy Modesty Bracket

Understanding  
▶ Page 108  
Specifying  
▶ Page 118



### Height Adjustable Bracket

Understanding  
▶ Page 108  
Specifying  
▶ Page 119

### 3F Hanging Panels

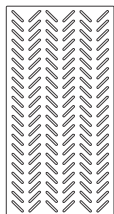
Understanding  
 ▶ Page 106  
 Specifying  
 ▶ Page 109



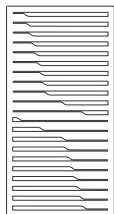
Solid



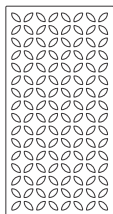
Skyline



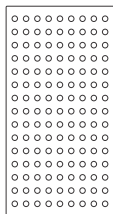
Array



Stairstep



Clover



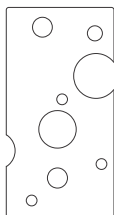
Polka



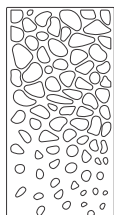
Palm



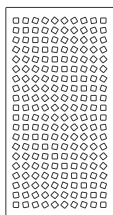
Botanica



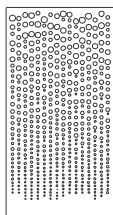
Bubbles



Pebbles

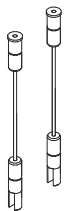


Cubes

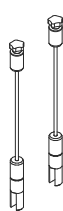


Shimmer

### 3F Panel Suspension Kits



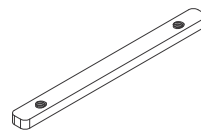
**Ceiling Suspension Kit**  
 Specifying  
 ▶ Page 116



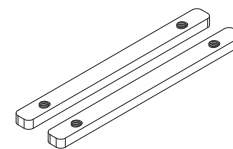
**Rail Suspension Kit**  
 Specifying  
 ▶ Page 116



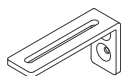
**Rail Sliding Kit**  
 Specifying  
 ▶ Page 116



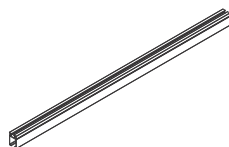
**Single Rail Bridge Extension Kit**  
 Specifying  
 ▶ Page 116



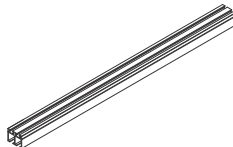
**Double Rail Bridge Extension Kit**  
 Specifying  
 ▶ Page 116



**Rail Wall Mounting Kit**  
 Specifying  
 ▶ Page 116



**50" Single Rail**  
 Specifying  
 ▶ Page 116



**50" Double Rail**  
 Specifying  
 ▶ Page 116

**3F Wall Tiles**

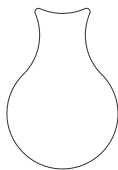
Understanding  
▶ Page 107  
Specifying  
▶ Page 110



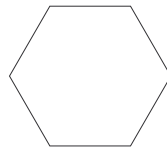
Trapezoid



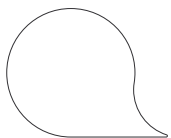
Stripe



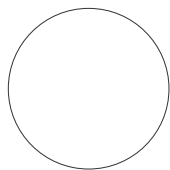
Drop



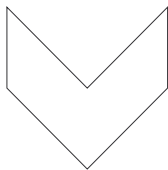
Hexagon



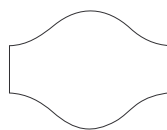
Balloon



Circle



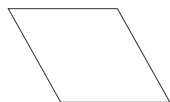
Chevron



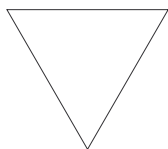
Belt



Square



Rhombus



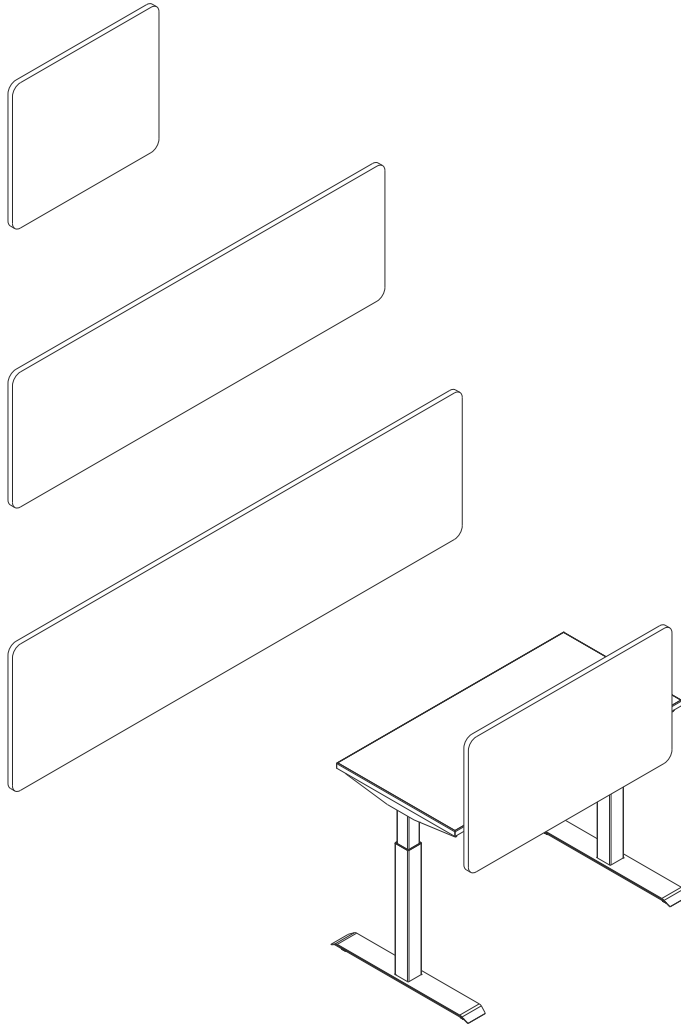
Triangle



Dome

# 3F Linear Privacy and Modesty Screens

**3F linear screens** offer privacy and modesty solutions designed for height-adjustable and fixed worksurfaces.



## Actual Dimensions

<b>Width</b>	23", 28", 30", 36", 38", 40", 42", 44", 46", 50", 52", 56", 58", 62", 64", 68", and 70"
<b>Height</b>	13", 18", 23", and 28"
<b>Thickness</b>	18 mm/.7"

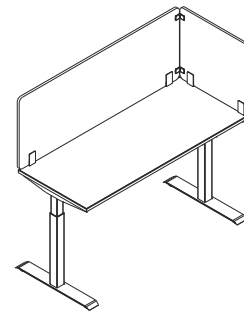
## Product Details

**Linear screens** are available in four heights—13"H, 18"H, 23"H, and 28"H and with widths ranging from 23"W to 70"W.

**Side screens** are available in rectangular, round, and slope shapes.

**Worksurface side screen applications** are achieved through the use of shorter-width linear screens.

**Modesty screens** are available as 13"H linear panels mounted with L-brackets to provide below-worksurface modesty. L-brackets must be specified separately.



**The L-bracket** features an etched alignment line that indicates a 1" spacing between the worksurface and screen, facilitating cable feed-through.

**Modesty screens** are compatible for use in conjunction with privacy screens.

## Application Topics

**3F privacy screens** are compatible with all 3F mounting brackets.

**Linear back screens** are offered in both rectangular and round shapes.

**Brackets** are not included with linear screens and must be specified separately.

**Privacy screens** support both top-mount and outer-wrapped mounting applications.

**Screen width** may be equal to or less than the width of the attached worksurface; limitations may apply based on the location of worksurface legs and structural supports.

*Tip: It is recommended that CET SmartTools planning aid to verify proper screen and worksurface/table compatibility and application.*

## Surface Materials

### PET Screen

- FC1 Briquette
- FC2 Shadow
- FC3 Ash
- FC4 Pearl
- FC5 Celestial
- FC9 Sand
- FC10 Seafoam
- FC11 Warm White
- FC12 Midnight

# 3F L-Screens

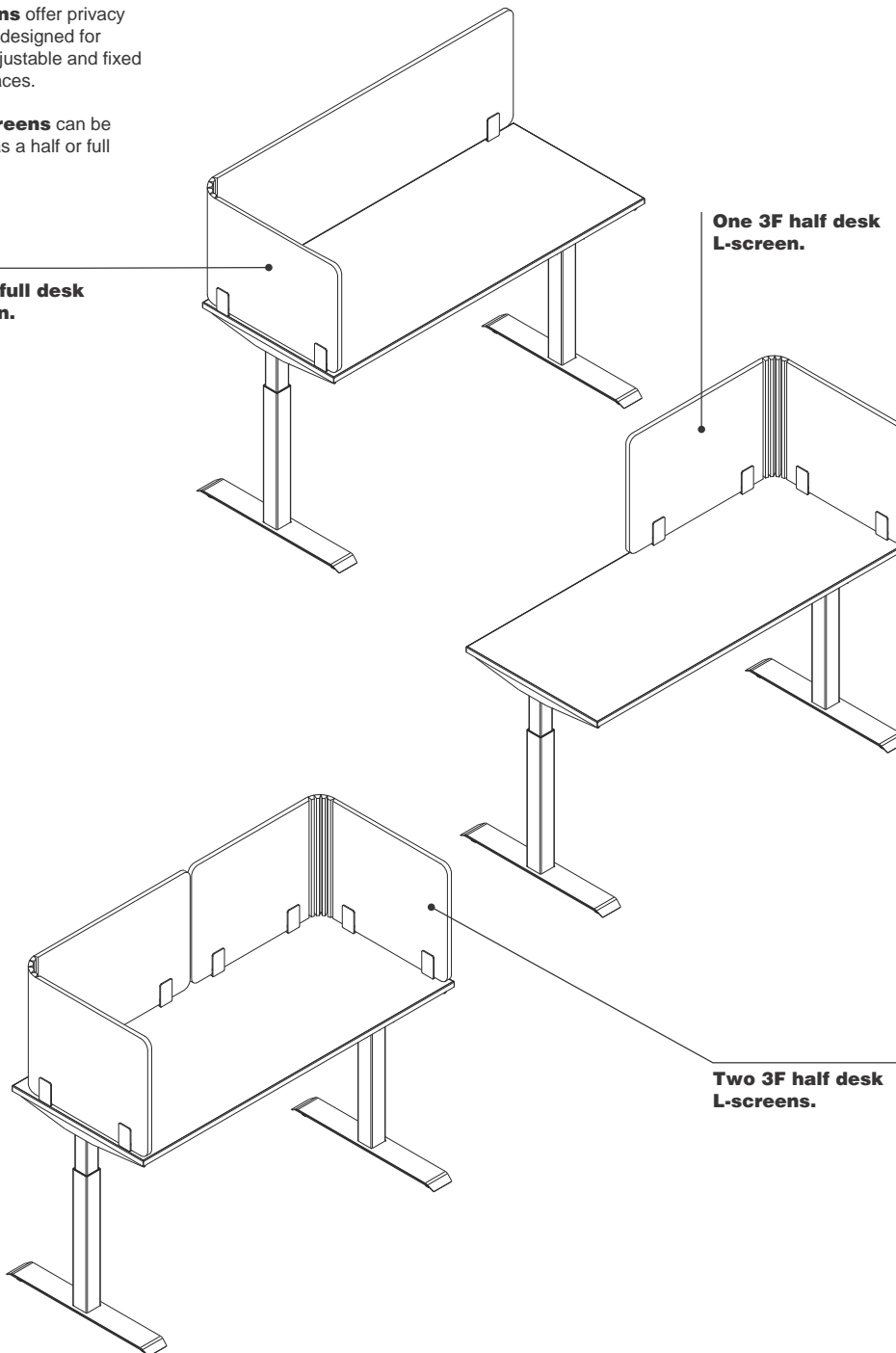
**3F full and half desk L-screens** offer privacy solutions designed for height-adjustable and fixed workspaces.

**3F L-screens** can be ordered as a half or full screen.

**One 3F full desk L-screen.**

**One 3F half desk L-screen.**

**Two 3F half desk L-screens.**



## Product Details

**Full L-screens** are compatible with any brackets other than height-adjustable brackets. Screen brackets must be specified separately.

**Two half desk L-screens** are required to wrap a full workspace.

**Half desk L-screens** are available in both top mount and outer-wrapped applications.

**Top mount** is compatible with top mounted brackets, except for half desk L-screens with 28"H.

**Outer wrapped** is compatible with sleeve brackets and fixed privacy modesty brackets.

## Application Topics

**Full L-screens** are design for modular-width desks and are intended to span roughly two-thirds of the workspace's rear when installed.  
*Tip: It is recommended that CET SmartTools planning aid to verify proper screen and workspace/table compatibility and application.*

**Half desk screens** are designed to fit modular desk sizes. Installing a pair on a non-modular desk will result in a visible gap between the screens.  
*Tip: It is recommended that CET SmartTools planning aid to verify proper screen and workspace/table compatibility and application.*

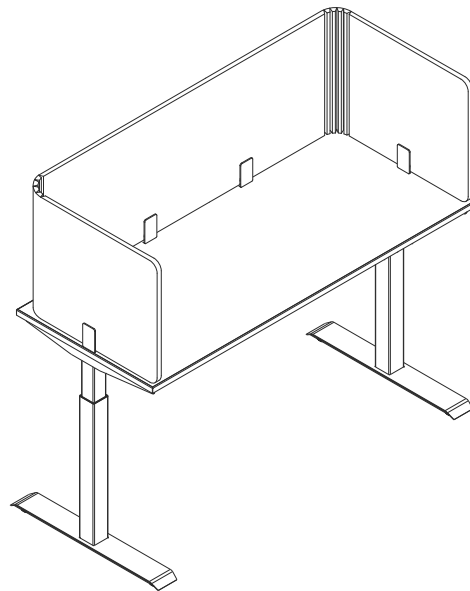
## Surface Materials

- PET Screen**
- FC1 Briquette
  - FC2 Shadow
  - FC3 Ash
  - FC4 Pearl
  - FC5 Celestial
  - FC9 Sand
  - FC10 Seafoam
  - FC11 Warm White
  - FC12 Midnight

## Actual Dimensions

<b>Width</b>	23", 28", 30", 36", 38", 40", 42", 44", 46", 50", 52", 56", 58", 62", 64", 68", and 70"
<b>Height</b>	13", 18", 23", and 28"
<b>Thickness</b>	18 mm/.7"

**3F U-screens** are tackable privacy screens designed to provide enhanced visual privacy on three sides of height-adjustable and fixed worksurfaces.



## Product Details

**Screen brackets** must be specified separately.

## Application Topics

**3F U-screens** are available in both top mount and outer-wrapped applications. Top mount is compatible with top mounted brackets, except for U-screens with 28"H. Outer wrapped is compatible with sleeve brackets and fixed privacy modesty brackets.

## Surface Materials

### PET Screen

- FC1 Briquette
- FC2 Shadow
- FC3 Ash
- FC4 Pearl
- FC5 Celestial
- FC9 Sand
- FC10 Seafoam
- FC11 Warm White
- FC12 Midnight

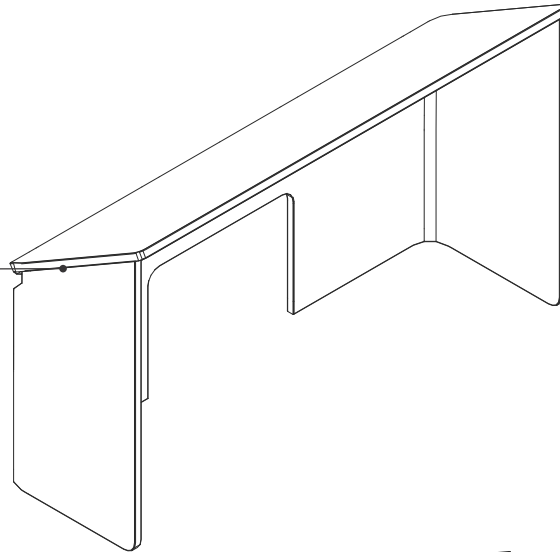
## Actual Dimensions

<b>Width/Depth</b>	46"W/20"D, 48"W/20"D, 52"W/20"D, 54"W/20"D, 58"W/18"D, 60"W/17"D, 64"W/15"D, 66"W/14"D, 70"W/12"D, and 72"W/11"D
<b>Height</b>	13", 18", 23", and 28"
<b>Thickness</b>	18 mm/.7"

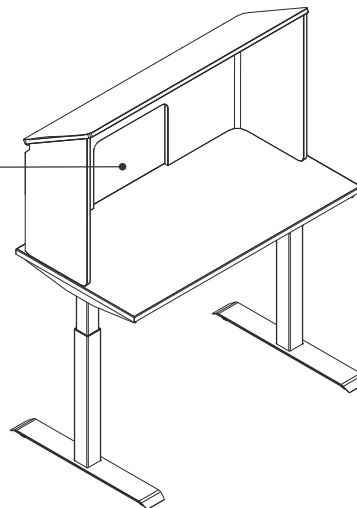
# 3F Hooded Screens

**3F hooded screen** provides overhead privacy, giving users greater confidentiality at their workstations while also minimizing visual distractions from surrounding activity, helping them stay focused and productive in busy environments.

**Hooded screen applications** are compatible only with top-mount brackets. Mounting brackets must be specified separately.



**Hooded screens** include a rear cutout that supports monitor arm clamping or may be left plugged when monitor arms are not used.



## Actual Dimensions

<b>Width</b>	48", 54", 60", 66", and 72"
<b>Height</b>	30"
<b>Roof Angle</b>	30°
<b>Thickness</b>	18 mm/.7"

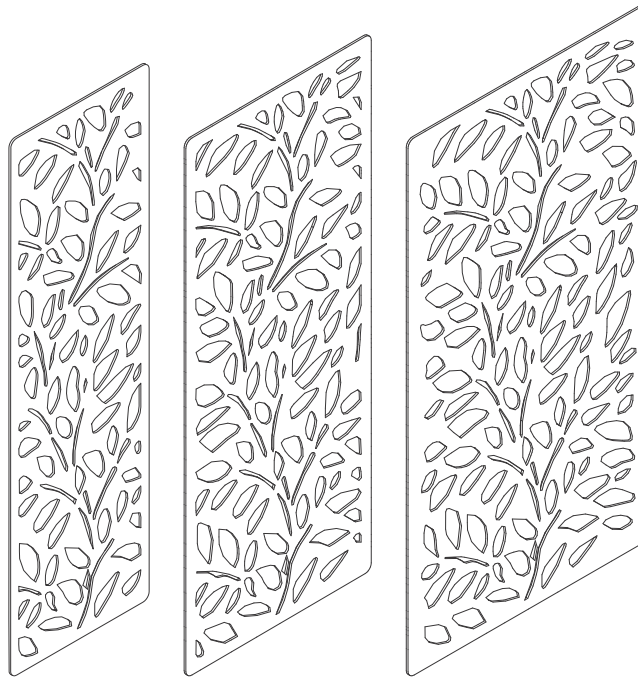
## Surface Materials

- PET Screen**
- FC1 Briquette
  - FC2 Shadow
  - FC3 Ash
  - FC4 Pearl
  - FC5 Celestial
  - FC9 Sand
  - FC10 Seafoam
  - FC11 Warm White
  - FC12 Midnight



# 3F Hanging Panels

**3F hanging panels** are modular ceiling-suspended panel solutions designed to support visual separation and enhance acoustic performance in open environments.



## Product Details

**Hanging panels** are available as either solid panels or with a range of organic and geometric patterned cutouts.

## Application Topics

**Hanging panels** supports wide range of ceiling heights and privacy applications.

## Surface Materials

### PET Screen

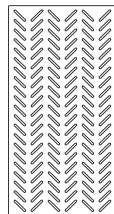
- FC1 Briquette
- FC2 Shadow
- FC3 Ash
- FC4 Pearl
- FC5 Celestial
- FC9 Sand
- FC10 Seafoam
- FC11 Warm White
- FC12 Midnight



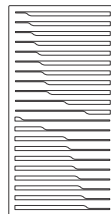
Solid



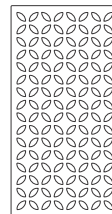
Skyline



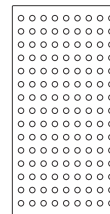
Array



Stairstep



Clover



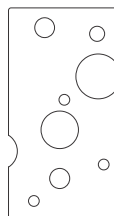
Polka



Palm



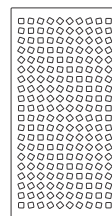
Botanica



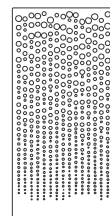
Bubbles



Pebbles



Cubes



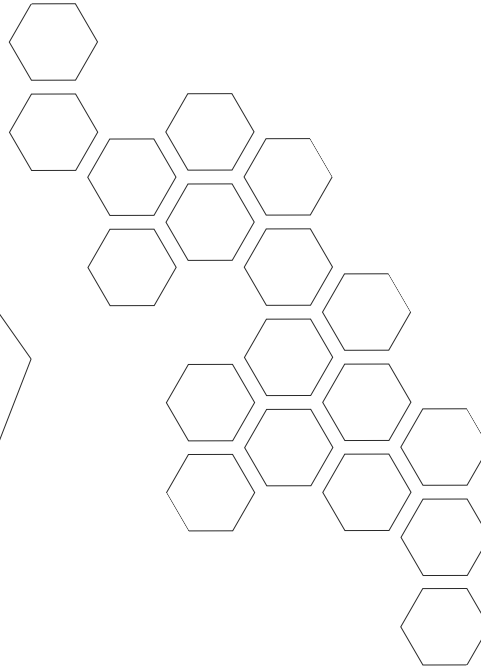
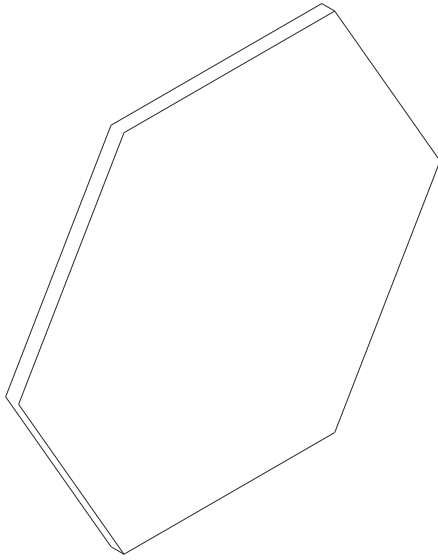
Shimmer

## Actual Dimensions

<b>Width</b>	94"
<b>Height</b>	28", 38", and 48"
<b>Weight</b>	7 lbs, 10 lbs, and 12 lbs
<b>Thickness</b>	9 mm/.35"

*Tip: Weight of hanging panel may decrease when specifying patterns.*

**3F wall tiles** provide modular, wall-mounted visual and acoustic solution designed for flexible space planning and acoustic performance.



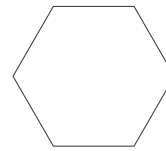
Trapezoid



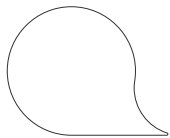
Stripe



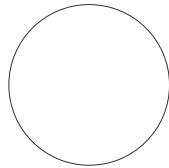
Drop



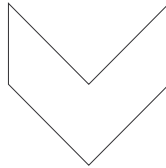
Hexagon



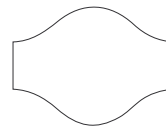
Balloon



Circle



Chevron



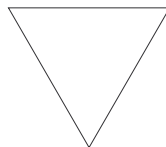
Belt



Square



Rhombus



Triangle



Dome

### Actual Dimensions

<b>Width</b>	11.5"
<b>Thickness</b>	9 mm/.35"

### Product Details

**Wall tiles** are designed for direct attachment to architectural wall surface for semi-permanent installation.

**Wall tile tape** must be specified separately.

*Tip: One roll of tape is recommended per 30 wall tiles during application.*

**Wall tiles** are available in multiple shapes and finishes to support a wide range of aesthetic and functional applications.

### Surface Materials

#### PET Screen

- FC1 Briquette
- FC2 Shadow
- FC3 Ash
- FC4 Pearl
- FC5 Celestial
- FC9 Sand
- FC10 Seafoam
- FC11 Warm White
- FC12 Midnight

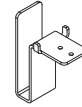
# 3F Brackets

Several connection options are available for 3F.

**3F offers a variety of brackets designed to support multiple mounting applications,** including height-adjustable desks, fixed worksurfaces, and benching applications.

## Overview

**3F Sleeve Brackets** mount beneath the worksurface to support height-adjustable and fixed applications, while maintaining clearance for worktools and cable routing.



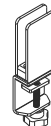
**3F Fixed Privacy and Modesty Brackets** clamp to the worksurface to support applications requiring privacy and modesty, while maintaining clearance for worktools and cable management.



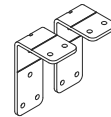
**3F Top Mount Brackets** are designed for direct installation on the top of a worksurface or desk surface, supporting top-mounted applications that require privacy where worktools and cable clearance are not required.



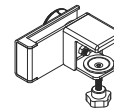
**3F Top Mount Clamp Brackets** offer a clamp-on solution that secures to the desk edge, delivering privacy for top-mounted applications when worktools and cable clearance are not required.



**3F Modesty and Privacy L-Brackets** mount beneath the worksurface and provide flexible support for modesty and privacy applications. The L-bracket design accommodates 13"H linear screens for modesty-only use, or can be configured to support both privacy and modesty. Installation flexibility allows the bracket to be positioned with or without a gap - creating space for cord drop and worktool integration when needed.



**3F Height Adjustable Brackets** clamp directly to the desk to support privacy and modesty screen applications on height-adjustable workstations, allowing users to adjust screen height for flexibility.



**3F Corner Connectors** support corner connections when linear back screens and side screens are installed as top-mounted applications on a single worksurface.



**Kinex Screen Clips** mount directly to the beam of the Kinex Benching System and ILINE beam, providing screen support for privacy applications in both benching and height-adjustable desk environments.





Standard Includes	Required to Specify
<ul style="list-style-type: none"> <li>• 94"L hanging panel: Verve felt</li> </ul>	<ul style="list-style-type: none"> <li>1 Style number</li> <li>2 Fabric color number for panel</li> <li>3 Options, If selected (see below)</li> <li>▶ See <i>Surface Materials</i>, page 506.</li> </ul>

Pattern	Options	U.S. Price	Required to Specify
	• Array	No cost	Specify with <i>Array</i> .
	• Botanica	No cost	Specify with <i>Botanica</i> .
	• Bubbles	No cost	Specify with <i>Bubbles</i> .
	• Clover	No cost	Specify with <i>Clover</i> .
	• Cubes	No cost	Specify with <i>Cubes</i> .
	• Palm	No cost	Specify with <i>Palm</i> .
	• Pebbles	No cost	Specify with <i>Pebbles</i> .
	• Polka	No cost	Specify with <i>Polka</i> .
	• Shimmer	No cost	Specify with <i>Shimmer</i> .
	• Skyline	No cost	Specify with <i>Skyline</i> .
	• Solid	No cost	Specify with <i>Solid</i> .
	• Stairstep	No cost	Specify with <i>Stairstep</i> .

Specification Information			
• Style Number	• U.S. Prices		
	• Width		
	28"W	38"W	48"W
<b>3FHPHANGINGPNL</b>	\$735	\$959	\$1182



**For Canadian Pricing**  
 Multiply U.S. Price by the Canadian price factor.  
 ▶ See page 1 for details.

# 3F Wall Tile



Tip: Wall tile tape is specified separately.

Standard Includes	Required to Specify
<ul style="list-style-type: none"> <li>Verve felt wall tile</li> </ul>	1 Style number 2 Fabric color number for tile ▶ See <i>Surface Materials</i> , page 506.

## Specification Information

• Style • Number	• U.S. • Price

### Dome, Stripe, and Trapezoid

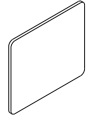
<b>3FWTTILE</b>	\$35
-----------------	------

### Balloon, Belt, Chevron, Circle, Drop, Hexagon, Rhombus, Square, and Triangle

<b>3FWTTILE</b>	\$50
-----------------	------



**For Canadian Pricing**  
 Multiply U.S. Price by the  
 Canadian price factor.  
 ▶ See page 1 for details.



Tip: Compatible with any bracket.

Tip: Screen brackets are specified separately.

Tip: Slope shape are only available with side screens.

Standard Includes	Required to Specify
<ul style="list-style-type: none"> <li>Desk screen: Verve felt</li> </ul>	1 Style number 2 Fabric color number for screen 3 Options, if selected (see below) ▶ See <i>Surface Materials</i> , page 506.

Options	U.S. Price	Required to Specify
<b>Shape</b> <ul style="list-style-type: none"> <li>Rectangular</li> <li>Round</li> <li>Slope</li> </ul>	No cost No cost No cost	Specify with <i>rectangular</i> . Specify with <i>round</i> . Specify with <i>slope</i> .

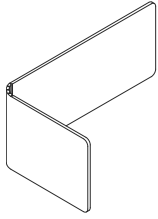
Specification Information											
Style Number	Dimensions Height	U.S. Prices									
		Width									
		23"W	28"W	30"W	36"W	38"W	40"W	42"W	44"W	46"W	50"W
<b>3FNSLINEAR</b>	13"	\$142	\$170	\$191	\$227	\$232	\$238	\$246	\$253	\$268	\$296
	18"	\$156	\$184	\$205	\$241	\$247	\$253	\$261	\$268	\$282	\$310
	23"	\$170	\$198	\$219	\$255	\$262	\$268	\$275	\$282	\$296	\$326
	28"	\$198	\$226	\$248	\$282	\$289	\$295	\$303	\$310	\$326	\$353

▶ Specification Information, continued from above

Style Number	Dimensions Height	U.S. Prices						
		Width						
		52"W	56"W	58"W	62"W	64"W	68"W	70"W
<b>3FNSLINEAR</b>	13"	\$312	\$340	\$354	\$382	\$397	\$425	\$438
	18"	\$326	\$353	\$368	\$396	\$410	\$439	\$452
	23"	\$339	\$368	\$382	\$410	\$423	\$452	\$465
	28"	\$368	\$396	\$410	\$439	\$452	\$482	\$493

**For Canadian Pricing**  
 Multiply U.S. Price by the Canadian price factor.  
 ▶ See page 1 for details.

# 3F Full Desk L-Screen



Tip: Compatible with any bracket other than height adjustable bracket.

Tip: Full desk L-screens have a 23" side depth.

Tip: Screen brackets are specified separately.

Tip: 3F full desk L-screens are handed when the slope shape is selected.

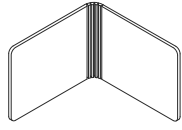
Standard Includes	Required to Specify
<ul style="list-style-type: none"> <li>Desk screen: Verve felt</li> </ul>	<ol style="list-style-type: none"> <li>Style number</li> <li>Fabric color number for screen</li> <li>Options, if selected (see below)</li> </ol> <p>▶ See <i>Surface Materials</i>, page 506.</p>

	Options	U.S. Price	Required to Specify
<b>Shape</b>	<ul style="list-style-type: none"> <li>Rectangular</li> <li>Round</li> <li>Slope</li> </ul>	No cost No cost No cost	Specify <i>with rectangular</i> . Specify <i>with round</i> . Specify <i>with slope</i> .
<b>Handedness</b>	<ul style="list-style-type: none"> <li>Right-handedness</li> <li>Left-handedness</li> </ul>	No cost No cost	Specify <i>with right-handedness</i> . Specify <i>with left-handedness</i> .

Specification Information											
Style Number	Dimensions Height	U.S. Prices									
		Width									
		44"W	46"W	50"W	52"W	56"W	58"W	62"W	64"W	68"W	70"W
<b>3F5NLSCREEN</b>	13"	\$420	\$439	\$460	\$480	\$502	\$529	\$551	\$573	\$595	\$615
	18"	\$432	\$460	\$481	\$501	\$523	\$550	\$572	\$594	\$616	\$636
	23"	\$465	\$487	\$503	\$537	\$553	\$578	\$593	\$621	\$636	\$671
	28"	\$507	\$530	\$550	\$578	\$598	\$621	\$641	\$664	\$684	\$713



**For Canadian Pricing**  
 Multiply U.S. Price by the Canadian price factor.  
 ▶ See page 1 for details.



Standard Includes		Required to Specify	
<ul style="list-style-type: none"> <li>Desk screen: Verve felt</li> </ul>		<ul style="list-style-type: none"> <li>1 Style number</li> <li>2 Fabric color number for screen</li> <li>3 Options, if selected (see below)</li> <li>▶ See <i>Surface Materials</i>, page 506.</li> </ul>	
Options	U.S. Price	Required to Specify	
<b>Mount</b> <ul style="list-style-type: none"> <li>Outer wrapped</li> <li>Top mount</li> </ul>	No cost No cost	Specify with <i>outer wrapped</i> . Specify with <i>top mount</i> .	
<b>Shape</b> <ul style="list-style-type: none"> <li>Rectangular</li> <li>Round</li> <li>Slope</li> </ul>	No cost No cost No cost	Specify with <i>rectangular</i> . Specify with <i>round</i> . Specify with <i>slope</i> .	
<b>Handedness</b> <ul style="list-style-type: none"> <li>Right-handedness</li> <li>Left-handedness</li> </ul>	No cost No cost	Specify with <i>right-handedness</i> . Specify with <i>left-handedness</i> .	

Specification Information														
Style Number	Dimensions		U.S. Prices											
	D	H	Width											
			23"W	24"W	26"W	27"W	29"W	30"W	32"W	33"W	35"W	36"W	38"W	42"W
<b>3FSNHALFDESK</b>	24" or 30"	13"	\$328	\$341	\$360	\$375	\$396	\$421	\$436	\$448	\$467	\$484	\$499	\$514
	24" or 30"	18"	\$347	\$360	\$379	\$394	\$415	\$439	\$454	\$466	\$483	\$501	\$516	\$531
	24" or 30"	23"	\$376	\$388	\$407	\$422	\$443	\$465	\$480	\$493	\$517	\$530	\$544	\$559
	24" or 30"	28"	\$418	\$430	\$449	\$464	\$485	\$509	\$523	\$536	\$553	\$572	\$587	\$601

*Tip: Half desk L-screens are non-handed. Two half desk L-screens are required to wrap a full worksurface.*

*Tip: Top mount is compatible with top mounted brackets, except for half desk L-screens with 28"H.*

*Tip: Half desk L-screens are designed to work with modular sized worksurfaces from 46"W to 84"W. Mounting a pair of screens on a different size worksurface will create a gap between the screens.*

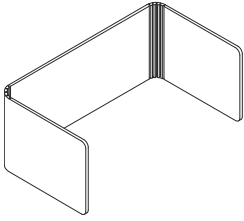
*Tip: Outer wrapped is compatible with sleeve brackets, fixed privacy modesty brackets, and L-brackets.*

*Tip: Screen brackets are specified separately.*

*Tip: 3F full desk L-screens are handed when the slope shape is selected.*

 **For Canadian Pricing**  
Multiply U.S. Price by the Canadian price factor.  
▶ See page 1 for details.

# 3F U-Screen



Tip: Top mount is compatible with top mounted brackets, except for U-screens with 28"H.

Tip: Outer wrapped is compatible with sleeve brackets, fixed privacy modesty brackets, and L-brackets.

Tip: Depth dimensions may vary depending on bracket mount type.

Tip: Screen brackets are specified separately.

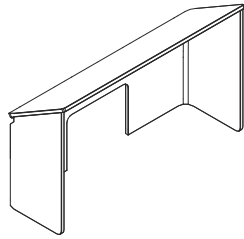
Standard Includes	Required to Specify
<ul style="list-style-type: none"> <li>Desk screen: Verve felt</li> </ul>	<ul style="list-style-type: none"> <li>1 Style number</li> <li>2 Fabric color number for screen</li> <li>3 Options, if selected (see below)</li> <li>▶ See <i>Surface Materials</i>, page 506.</li> </ul>

	Options	U.S. Price	Required to Specify
<b>Mount</b>	<ul style="list-style-type: none"> <li>Outer wrapped</li> <li>Top mount</li> </ul>	No cost No cost	Specify with <i>outer wrapped</i> . Specify with <i>top mount</i> .
<b>Shape</b>	<ul style="list-style-type: none"> <li>Rectangular</li> <li>Round</li> <li>Slope</li> </ul>	No cost No cost No cost	Specify with <i>rectangular</i> . Specify with <i>round</i> . Specify with <i>slope</i> .

Specification Information											
Style Number	Dimensions Height	U.S. Prices									
		46"W/ 20"D	48"W/ 20"D	52"W/ 20"D	54"W/ 20"D	58"W/ 18"D	60"W/ 17"D	64"W/ 15"D	66"W/ 14"D	70"W/ 12"D	72"W/ 11"D
<b>3F3NUSCREEN</b>	18"	\$559	\$578	\$607	\$630	\$659	\$683	\$712	\$727	\$752	\$786
	18"	\$606	\$621	\$649	\$671	\$699	\$713	\$743	\$756	\$784	\$811
	23"	\$649	\$671	\$699	\$713	\$743	\$756	\$784	\$798	\$826	\$840
	28"	\$706	\$727	\$756	\$769	\$798	\$811	\$840	\$853	\$882	\$899



**For Canadian Pricing**  
Multiply U.S. Price by the Canadian price factor.  
▶ See page 1 for details.



*Tip: Hooded screens only compatible with top mount bracket.*

*Tip: The removable monitor arm cut-out ships with the hooded screen and is designed to accommodate applications with or without monitor arms.*

*Tip: The cut-out can be removed to clamp monitor arms or can be plugged into the opening if monitor arms are not being used.*

Standard Includes	Required to Specify
-------------------	---------------------

- Desk screen: Verve felt

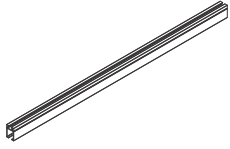
- 1 Style number
- 2 Fabric color number for screen
- ▶ See *Surface Materials*, page 506.

Specification Information					
Style Number	U.S. Prices				
	48"W	54"W	60"W	66"W	72"W
<b>3FSNHOODED</b>	\$785	\$839	\$890	\$946	\$999

 **For Canadian Pricing**  
 Multiply U.S. Price by the Canadian price factor.  
 ▶ See page 1 for details.

# 3F Panel Suspension Kits

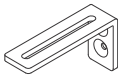
## 3F Rail



Tip: When ordering a 3F rail, you must also order a rail suspension mount, a rail sliding mount, or a wall mount.

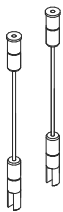
Standard Includes		Required to Specify	
<ul style="list-style-type: none"> <li>Mounting rail beam</li> <li>Attachment hardware</li> </ul>		1 Style number 2 Options, if selected (see below)	
Options	U.S. Price	Required to Specify	
<b>Extension Kit</b>	<ul style="list-style-type: none"> <li>Single rail +\$15</li> <li>Double rail +\$28</li> </ul>	Specify with <i>single rail extension kit</i> . Specify with <i>double rail extension kit</i> .	
<b>Mount</b>	<ul style="list-style-type: none"> <li>Wall mount +\$37</li> </ul>	Specify with <i>wall mount</i> .	
Specification Information			
Style Number	U.S. Base Prices		
	50" Single Rail	50" Double Rail	
<b>3FHPRAILKIT</b>	\$178	\$252	

## 3F Rail Mount Kit



Standard Includes		Required to Specify	
<ul style="list-style-type: none"> <li>Suspension mount: set of two 5'L steel cables</li> <li>Sliding mount: sliding glider bracket</li> <li>Attachment hardware</li> </ul>		Style number	
Specification Information			
Style Number	U.S. Prices		
	Rail Suspension Mount	Rail Sliding Mount	
<b>3FHPMOUNTKIT</b>	\$60	\$155	

## 3F Ceiling Kit



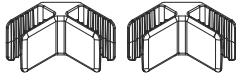
Tip: Rails can be positioned adjacent to each other to build a multi-rail system.

Standard Includes		Required to Specify	
<ul style="list-style-type: none"> <li>Set of two 5'L steel cables</li> <li>Attachment hardware</li> </ul>		Style number	
Specification Information			
Style Number	U.S. Price		
<b>X-3F-SUSPENSION</b>	\$134		



**For Canadian Pricing**  
 Multiply U.S. Price by the Canadian price factor.  
 ▶ See page 1 for details.

## 3F Corner Connector



Standard Includes	Required to Specify
-------------------	---------------------

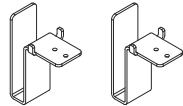
- Set of two corner connectors: paint

- 1 Style number
- 2 Paint color number for brackets
- ▶ See *Surface Materials*, page 506.

Specification Information	
---------------------------	--

Style Number	U.S. Price
3FSNCORNERCCT	\$63

## 3F Sleeve Bracket



*Tip: 1½" clearance is needed from edge of worksurface to cantilever.*

*Tip: Compatible with ¾" to 1¾" thick worksurfaces.*

Standard Includes	Required to Specify
-------------------	---------------------

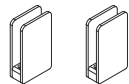
- Set of two sleeve brackets: paint

- 1 Style number
- 2 Paint color number for brackets
- ▶ See *Surface Materials*, page 506.

Specification Information	
---------------------------	--

Style Number	U.S. Price
3FSNSLEEVEBKT	\$79

## 3F Top Mount Bracket



*Tip: Compatible with ¾" to 1¾" thick worksurfaces.*

Standard Includes	Required to Specify
-------------------	---------------------

- Set of two top mount brackets: paint

- 1 Style number
- 2 Paint color number for brackets
- ▶ See *Surface Materials*, page 506.

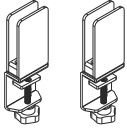
Specification Information	
---------------------------	--

Style Number	U.S. Price
3FSNTOPMOUNTBKT	\$84



**For Canadian Pricing**  
 Multiply U.S. Price by the Canadian price factor.  
 ▶ See page 1 for details.

### 3F Top Mount Bracket and Clamp Set



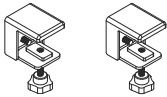
Tip: 1 1/2" clearance is needed from edge of worksurface to cantilever.

Tip: Compatible with 3/4" to 1 3/4" thick worksurfaces.

Standard Includes	Required to Specify
<ul style="list-style-type: none"> <li>Set of two top mount brackets: paint</li> </ul>	1 Style number 2 Paint color number for brackets ▶ See <i>Surface Materials</i> , page 506.

Specification Information	
Style Number	U.S. Price
<b>3FSNTOPMNTCLAMPBKT</b>	\$128

### 3F Fixed Privacy/Modesty Bracket



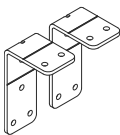
Tip: 1 1/2" clearance is needed from edge of worksurface to cantilever.

Tip: Compatible with 3/4" to 1 3/4" thick worksurfaces.

Standard Includes	Required to Specify
<ul style="list-style-type: none"> <li>Set of two desk screen brackets: paint</li> </ul>	1 Style number 2 Paint color number for brackets ▶ See <i>Surface Materials</i> , page 506.

Specification Information	
Style Number	U.S. Price
<b>3FSNFIXEDPRVCYBKT</b>	\$113

### 3F Modesty and Privacy L-Bracket



Tip: Used to mount 13"H screens in modesty applications.

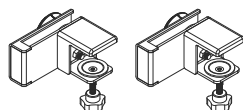
Standard Includes	Required to Specify
<ul style="list-style-type: none"> <li>Set of two L-brackets: F3 Black paint</li> </ul>	Style number

Specification Information	
Style Number	U.S. Price
<b>3FSNLBKT</b>	\$84



**For Canadian Pricing**  
 Multiply U.S. Price by the Canadian price factor.  
 ▶ See page 1 for details.

### 3F Height Adjustable Bracket



Tip: 1½" clearance is needed from edge of worksurface to cantilever.

Tip: Compatible with ¾" to 1¾" thick worksurfaces.

Tip: Height-adjustable brackets are not compatible with all 24"D worksurfaces.

Standard Includes	Required to Specify
-------------------	---------------------

- Set of two height-adjustable brackets: paint

- 1 Style number
- 2 Paint color number for brackets
- ▶ See *Surface Materials*, page 506.

Specification Information	
Style Number	U.S. Price

Style Number	U.S. Price
<b>3FSNHEIGHTADJBKT</b>	\$156

### 3F ILINE Mount Clip



Standard Includes	Required to Specify
-------------------	---------------------

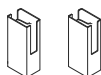
- Two screen mount clips: paint

- 1 Style number
- 2 Paint color number for brackets
- ▶ See *Surface Materials*, page 506.

Specification Information	
Style Number	U.S. Price

Style Number	U.S. Price
<b>3FSNILINEMOUNT</b>	\$165

### 3F Kinex Screen Clip — Double Run



Standard Includes	Required to Specify
-------------------	---------------------

- Set of two screen clips: paint

- 1 Style number
- 2 Paint color number for clips
- ▶ See *Surface Materials*, page 506.

Specification Information	
Style Number	U.S. Price

Style Number	U.S. Price
<b>3FSNKINEXCLIP</b>	\$174

 **For Canadian Pricing**  
 Multiply U.S. Price by the Canadian price factor.  
 ▶ See page 1 for details.

# 3F Screen Accessories

## 3F Tape Roll

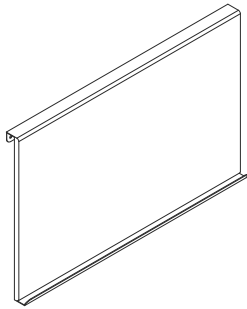
*Tip: One roll of tape is recommended per 30 wall tiles.*

Standard Includes		Required to Specify
<ul style="list-style-type: none"> <li>Industrial strength double sided tape for 3F wall tiles 1"W, 54 feet</li> </ul>		Style number

Specification Information	
Style Number	U.S. Price
<b>X-3F-TAPE</b>	\$123

## 3F Markerboard



*Tip: Recommended use with L- and U-screens only.*

Standard Includes		Required to Specify
<ul style="list-style-type: none"> <li>Hang-on markerboard</li> </ul>		Style number

Specification Information			
Dimensions		Style Number	U.S. Price
H	W		
14"	22"	<b>3FSNMB</b>	\$124



**For Canadian Pricing**  
 Multiply U.S. Price by the Canadian price factor.  
 ▶ See page 1 for details.

---

# REVI

**Understanding**

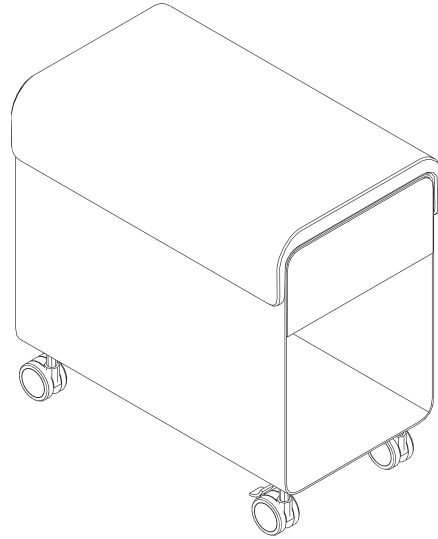
**122**

**Specifying**

**124**

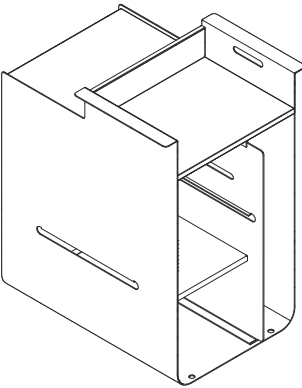
REVI

# Revi Pedestal Specifications



Housing Dimensions	13"w x 23.5"d x 22.75"h
Drawers	Push-to-open (no pulls or handles)
Drawer Depth	20"
Drawer Width	12.5"
Single/Dual Drawer Height	6"
File Drawer Height	12.25"
Maximum Drawer Extension	15.75"
Bag Drop Height	14"
Bag Drop Extension Range	.25" - 6.5"
Magnetic Cushion Thickness	.85"
Castors	2 locking, 2 non-locking
Bag Drop Castors	2 non-locking
Seated Weight Capacity	220 lbs
Bag Drop Weight Capacity	45 lbs
Lock Availability	Dual Drawer, Drawer + File
Certifications	ANSI/BIFMA X5.9-2019

# Revi Undermount Specifications



Housing Dimensions	10"W x 15"D x 18.5"H
Top Shelf Dimensions	10"W x 7.75"D x 2.5"H
Inside Clearance	10"W x 15"D x 15.5"H
Housing Finish Color	Platinum, White and Black
Personal Storage Bin Net Weight	15 lbs
Personal Storage Console Net Weight	18 lbs
Shelf Clearance below	6"
Shelf Clearance above	9"
Laptop Divider Clearance	3"W x 15"D x 15.5"H
Short Shelf Clearance	6.75"W x 15"D x 9"H
Bag Hook	1"W x 1"D x 2"H
File Pocket	1.25"W x 13"D x 5.5"H
Undermount Weight Capacity	80 lbs
Bag Hook Weight Capacity	15 lbs
File Pocket Weight Capacity	5 lbs
Door Rotation	135°
Certifications	ANSI/BIFMA X5.9-2019

# REVI Pedestal

Standard Includes	Required to Specify
<ul style="list-style-type: none"> <li>• Pedestal: paint</li> <li>• Steel top</li> <li>• Push-to-open (no pulls or handles)</li> <li>• Casters: two locking, two non-locking</li> </ul>	1 Style number 2 Paint color number for pedestal 3 Options, if selected (see below) ▶ See <i>Surface Materials</i> , page 506.

Options	U.S. Price	Required to Specify
<b>Surface Materials</b> <b>Swing door</b> <ul style="list-style-type: none"> <li>• Paint</li> </ul>	No cost	Specify paint color number.
<b>Bag Drop</b> <ul style="list-style-type: none"> <li>• Expandable</li> </ul>	+\$227	Specify <i>with expandable bag drop</i> .
<b>Bag Drop Finish</b> <ul style="list-style-type: none"> <li>• Paint</li> </ul>	No cost	Specify paint color number.
<b>Seat Cushion</b> <ul style="list-style-type: none"> <li>• Magnetic seat cushion</li> </ul>	+\$227	Specify <i>with magnetic seat cushion</i> .
<b>Seat Cushion Finish</b> <ul style="list-style-type: none"> <li>• Verve</li> </ul>	No cost	Specify Verve felt color number. ▶ See <i>Surface Materials</i> , page 506.
<b>Pencil Tray</b> <ul style="list-style-type: none"> <li>• Pencil tray</li> </ul>	+\$ 22	Specify <i>with pencil tray</i> .

Specification Information	
Style Number	U.S. Base Price

## Single Drawer

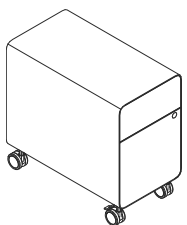
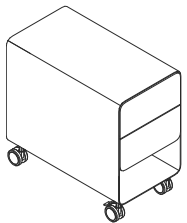
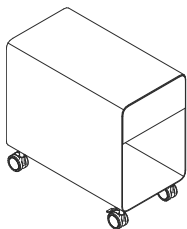
REVIPEDESTAL	\$586
--------------	-------

## Dual Drawer

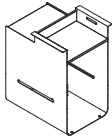
REVIPEDESTAL	\$664
--------------	-------

## Drawer/File

REVIPEDESTAL	\$706
--------------	-------



**For Canadian Pricing**  
 Multiply U.S. Price by the  
 Canadian price factor.  
 ▶ See page 1 for details.



Standard Includes	Required to Specify
<ul style="list-style-type: none"> <li>Steel storage: paint</li> <li>Hardware package</li> </ul>	<ol style="list-style-type: none"> <li>Style number</li> <li>Paint color number for storage</li> <li>Options, if selected (see below)</li> </ol> <p>▶ See <i>Surface Materials</i>, page 506.</p>

Options	U.S. Price	Required to Specify
<b>Surface Materials</b> <b>Swing door</b> <ul style="list-style-type: none"> <li>Paint</li> </ul>	No cost	Specify paint color number. ▶ See <i>Surface Materials</i> , page 506.
<b>Shelf</b> <ul style="list-style-type: none"> <li>Paint</li> </ul>	No cost	Specify paint color number. ▶ See <i>Surface Materials</i> , page 506.
<b>Door Type</b> <ul style="list-style-type: none"> <li>Left hinged</li> <li>Right hinged</li> </ul>	+\$ 99 +\$ 99	Specify <i>with left hinged door</i> . Specify <i>with right hinged door</i> .
<b>Shelf</b> <ul style="list-style-type: none"> <li>Shelf</li> <li>Laptop divider and short shelf</li> </ul>	+\$ 42 +\$113	Specify <i>with shelf</i> . Specify <i>with laptop divider and short shelf</i> .
<b>Bag Hook</b> <ul style="list-style-type: none"> <li>One bag hook</li> <li>Two bag hooks</li> </ul>	+\$ 27 +\$ 55	Specify <i>with one bag hook</i> . Specify <i>with two bag hooks</i> .
<b>File Pocket</b> <ul style="list-style-type: none"> <li>One file pocket</li> <li>Two file pockets</li> <li>Three file pockets</li> </ul>	+\$ 50 +\$ 99 +\$149	Specify <i>with one file pocket</i> . Specify <i>with two file pockets</i> . Specify <i>with three file pockets</i> .

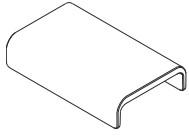
Specification Information	
Style Number	U.S. Base Price
REVIUNDERMOUNT	\$367



**For Canadian Pricing**  
 Multiply U.S. Price by the Canadian price factor.  
 ▶ See page 1 for details.

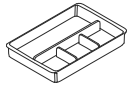
# Accessories

## REVI Cushion



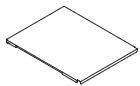
Standard Includes		Required to Specify
<ul style="list-style-type: none"> <li>Fabric cushion: Verve</li> </ul>		1 Style number 2 Fabric color number for cushion ▶ See <i>Surface Materials</i> , page 506.
Specification Information		
Style Number	U.S. Price	
REVICUSHION	\$227	

## REVI Pencil Tray



Standard Includes		Required to Specify
<ul style="list-style-type: none"> <li>Plastic pencil tray</li> </ul>		Style number
Specification Information		
Style Number	U.S. Price	
REVI-PNCLTRY	\$22	

## REVI Undermount Shelf



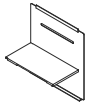
Standard Includes		Required to Specify
<ul style="list-style-type: none"> <li>Metal shelf: paint</li> </ul>		1 Style number 2 Paint color number for shelf ▶ See <i>Surface Materials</i> , page 506.
Specification Information		
Style Number	U.S. Price	
REVISHelf	\$42	



**For Canadian Pricing**  
 Multiply U.S. Price by the  
 Canadian price factor.  
 ▶ See page 1 for details.

REVI

## REVI Laptop Shelf



Standard Includes		Required to Specify
<ul style="list-style-type: none"> <li>Laptop shelf and divider: paint</li> </ul>		1 Style number 2 Paint color number for shelf ▶ See <i>Surface Materials</i> , page 506.
Specification Information		
Style Number	U.S. Price	
REVILAPTOPSHELF	\$113	

## Bag Hook




Standard Includes		Required to Specify
<ul style="list-style-type: none"> <li>Bag hook</li> </ul>		Style number
Specification Information		
Style Number	U.S. Price	
REVI-BH	\$27	

## REVI File Pocket



Standard Includes		Required to Specify
<ul style="list-style-type: none"> <li>File pocket</li> </ul>		Style number
Specification Information		
Style Number	U.S. Price	
REVI-FP	\$50	

 **For Canadian Pricing**  
 Multiply U.S. Price by the Canadian price factor.  
 ▶ See page 1 for details.



---

# S-SERIES

**Understanding** **130**

**Specifying** **134**

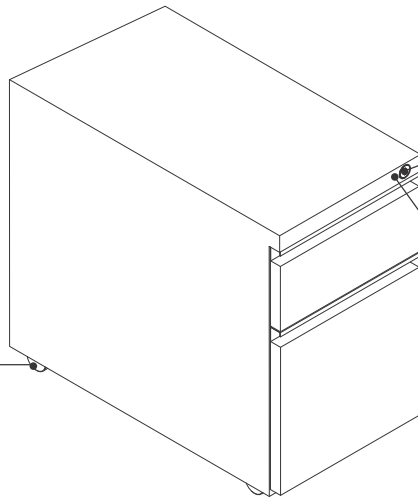
# S-Series Pedestals

**S-Series pedestals** are a mobile or freestanding private storage solution used to store away files, paperwork, and other personal items.

**Pedestals** include pencil tray, box drawer divider, file hanger, anti-tip counterweight, locking casters, and removable lock core.

**Field installed casters** are standard on 1.5-High mobile pedestals.

**Glides and casters** are standard on 2-High pedestals.



**15"W 1.5-High Mobile Pedestal (Box/File)**

**Locks** are standard on pedestals and come installed on each unit. Locks are available with random keying only. Locks are labeled as "PR" with three randomly selected numbers.

**To remove locks**, a core removal key must be specified separately (**SS-CRK**).

**Pedestal cushions** available in a variety of fabric colors.

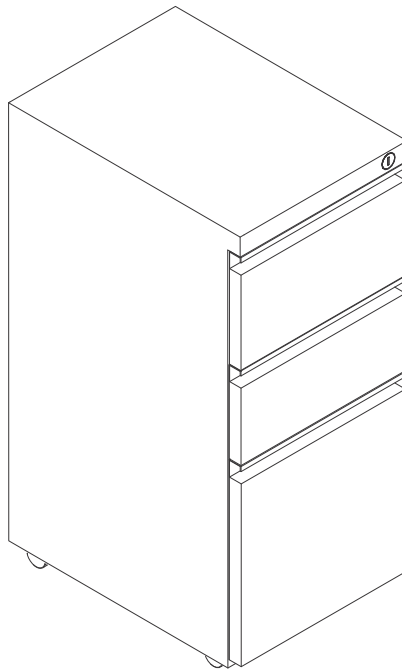
## Application

**S-Series 2-High pedestals** are only intended for freestanding or mobile applications. S-Series 2-High pedestals cannot be used under a worksurface or panel-mounted worksurface in fixed applications.

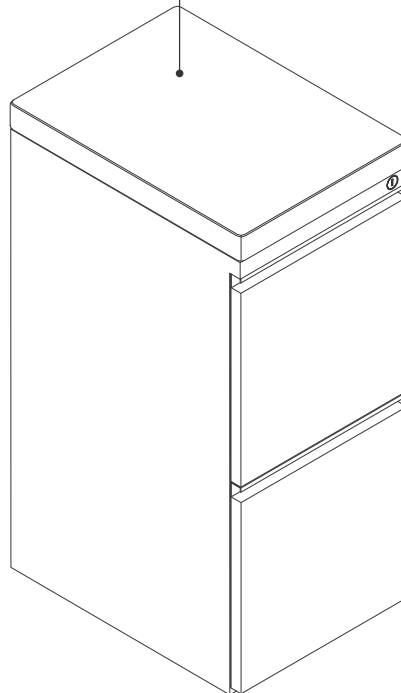
## Surface Materials

### Paint

- F1 Platinum
- F2 White
- F3 Black



**2-High Mobile/Freestanding (Box/Box/File) with Casters**



**2-High Mobile/Freestanding Pedestal (File/File) with Glides and Seat Cushion**

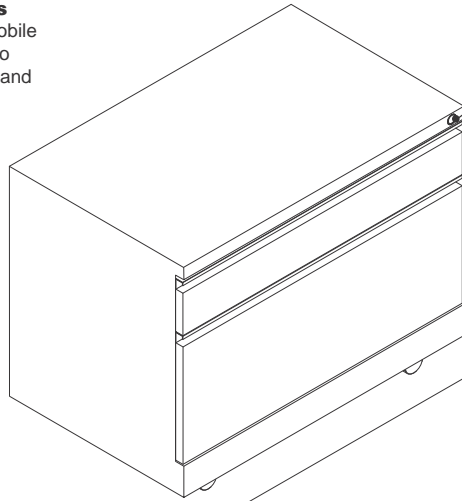
## Actual Dimensions

	1.5-High Mobile Pedestal (Box/File)	2-High Pedestal (Box/Box/File and File/File)	Enhanced Cushion
Depth	23"	19"	19" or 23"
Width	12" or 15"	15"	12" or 15"
Height with casters	21"	28"	2"

# S-Series Lateral Files and Bookcase

S-Series Lateral Files and Bookcase

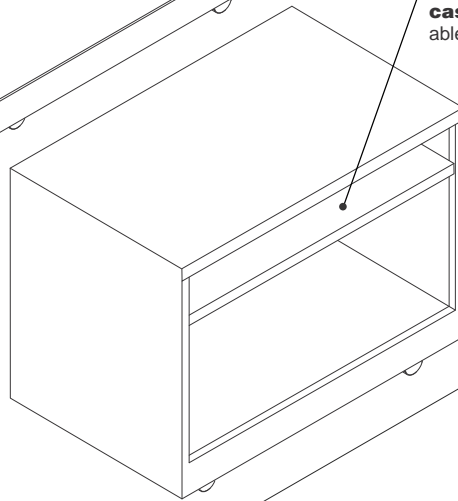
**S-Series lateral files and bookcase** are mobile storage solutions used to store and organize files and documents.



**1.5-High Lateral File with Drawers and Casters**

**Locks** are standard on lateral files and bookcase and come installed on each unit. Locks are available with random keying only. Locks are labeled as "PR" with three randomly selected numbers.

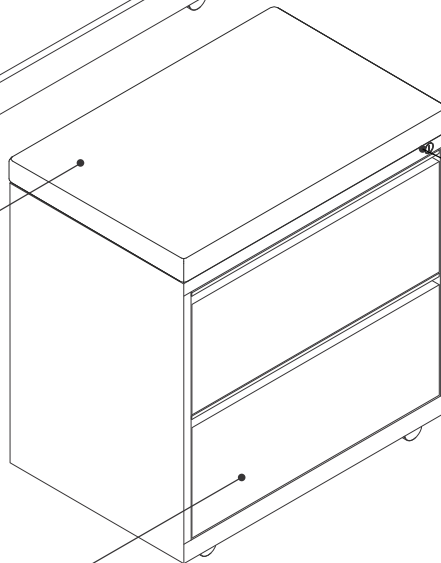
**1.5-High laterals and bookcase** are available in two finishes: platinum or white.



**1.5-High Bookcase with Casters**

**1.5-High bookcase with casters** include one adjustable shelf.

**2-High laterals** are available in three finishes: platinum, white, or black.



**2-High Lateral File with Casters**

**Lateral cushions** are ordered separately for 2-High laterals only.

**To remove locks**, a core removal key must be specified separately (**SS-CRK**).

**Field installed lateral file drawers** are standard with two hanging file frames.

## Application Topics

**S-Series 2-High laterals** are only intended for freestanding or mobile applications. S-Series 2-High laterals cannot be used under a worksurface or panel-mounted worksurface in fixed applications.

## Surface Materials

### Paint

- F1 Platinum
- F2 White
- F3 Black

*Tip: F3 Black is only available with the 2-High lateral.*

## Actual Dimensions

	1.5-High Lateral	Bookcase	2-High Lateral	Enhanced Cushion
Depth	18"	18"	20"	20"
Width	30"	30"	30"	30"
Height with casters	23"	23"	27"	2"

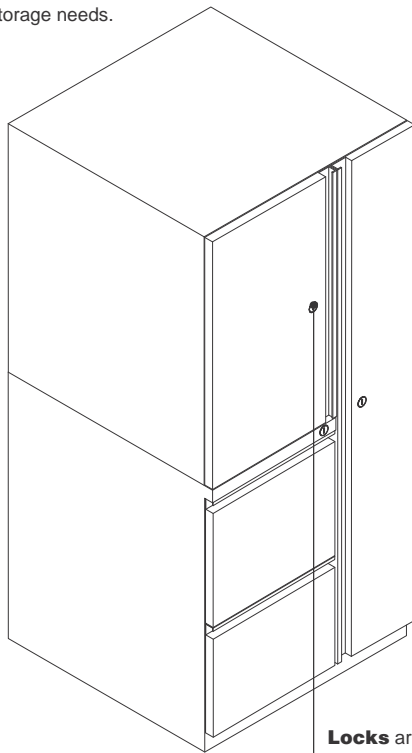
# S-Series Tower

**S-Series towers** provide users with storage spaces to file away paperwork and store other miscellaneous and personal items.

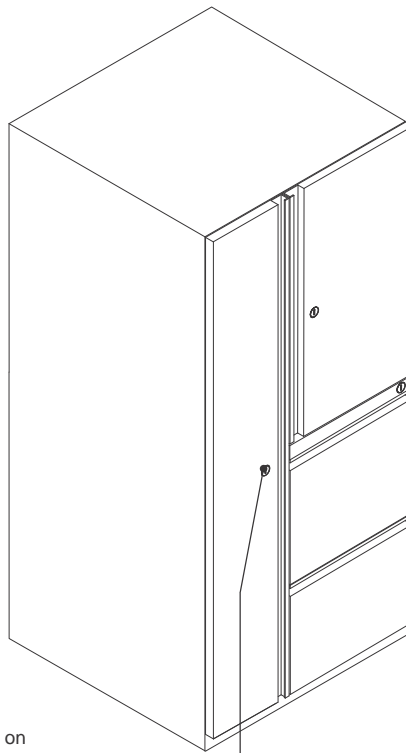
**Towers** include a hanger rod and shelves.

**Available** right-hinged or left-hinged.

**Metal shelves** can be adjusted to accommodate specific storage needs.



**Locks** are standard on towers and come installed on each unit. Locks are available with random keying only. Locks are labeled as "PR" with three randomly selected numbers.



**To remove locks**, a core removal key must be specified separately (**SS-CRK**).

## Surface Materials

### Paint

- F1 Platinum
- F2 White
- F3 Black

## Actual Dimensions

	Tower
Depth	24"
Width	24"
Height	53"

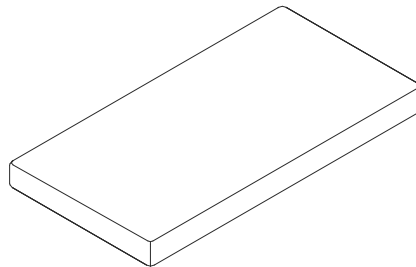
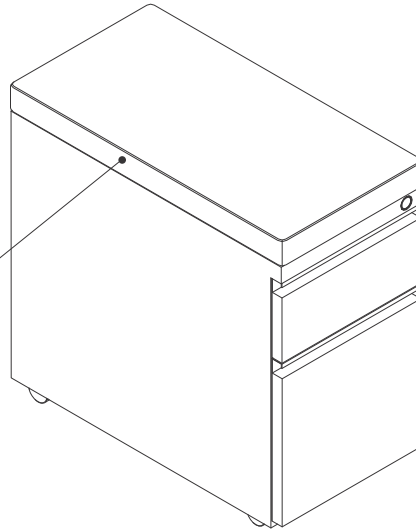
# S-Series Enhanced Cushion

S-Series Enhanced Cushion

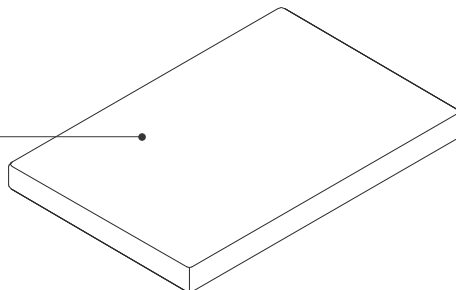
**Cushions** are ordered separately for use on S-Series pedestals and 2-High laterals.

**Cushions** are field-installed and attach to the existing top with a hook and loop fastener.

**Cushions** are available in 15 fabric finishes.



Pedestal cushion



Lateral cushion

**Lateral cushions** are compatible with 2-High laterals only.

## Surface Materials

- Fabric**
- Billiard

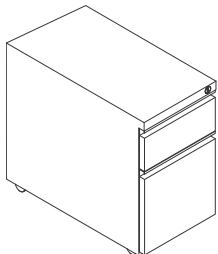
S-SERIES

## Actual Dimensions

	Depth	Width	Height
Enhanced Pedestal Cushion	19" or 23"	12" or 15"	2"
Enhanced Lateral Cushion	20"	30"	2"

# S-Series

## 1.5-High Mobile Pedestal



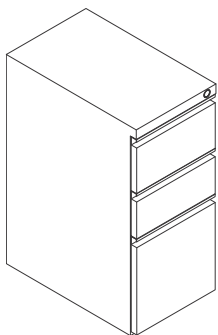
Standard Includes	Required to Specify
<ul style="list-style-type: none"> <li>▶ Need help? Product details, page 130</li> <li>• Steel storage pedestal: paint</li> <li>• Includes pencil tray, box drawer divider, file hanger, anti-tip counterweight, locking casters, and removable lock core</li> <li>• Casters</li> <li>• Lock, keyed random</li> </ul>	<ul style="list-style-type: none"> <li>1 Style number</li> <li>2 Paint color number for pedestal</li> <li>▶ See <i>Surface Materials</i>, page 506.</li> </ul>

Specification Information				
Style Number	Dimensions			U.S. Price
	D	W	H	

### S-SERIES 1.5-High Mobile Pedestal

Style Number	D	W	H	U.S. Price
SSRSPEDestal	23"	12"	21"	\$504
	23"	15"	21"	\$586

## 2-High Pedestal



Standard Includes	Required to Specify
<ul style="list-style-type: none"> <li>▶ Need help? Product details, page 130</li> <li>• 2-high pedestal: paint</li> <li>• Includes pencil tray, box drawer divider, file hanger, anti-tip counterweight, locking casters, full extension ball bearing glides, and removable lock core</li> <li>• Glides</li> <li>• Lock, keyed random</li> </ul>	<ul style="list-style-type: none"> <li>1 Style number</li> <li>2 Paint color number for pedestal</li> <li>3 Options, if selected (see below)</li> <li>▶ See <i>Surface Materials</i>, page 506.</li> </ul>

Storage	Options	U.S. Price	Required to Specify
	• File/file	No cost	Specify with <i>file/file storage</i> .
	• Box/box/file	+\$26	Specify with <i>box/box/file storage</i> .

Specification Information				
Style Number	Dimensions			U.S. Base Price
	D	W	H	

SSFP2H	19"	15"	28"	\$554
--------	-----	-----	-----	-------

Tip: Illustration above shows pedestal with box/box/file storage and glides.

Tip: S-Series 2-High pedestals are only intended for freestanding or mobile applications. Pedestals cannot be used under a worksurface or panel-mounted worksurface in fixed applications.

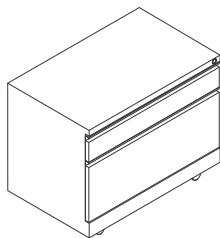


### For Canadian Pricing

Multiply U.S. Price by the Canadian price factor.

▶ See page 1 for details.

## 1.5-High Bookcase and Lateral File



Tip: Illustration above shows lateral file with drawers and casters.

Standard Includes	Required to Specify
-------------------	---------------------

<ul style="list-style-type: none"> <li>▶ Need help? Product details, page 131</li> <li>• Steel storage lateral: paint</li> <li>• Lock, keyed random, if lateral file with drawers selected</li> <li>• Glides</li> </ul>	<ol style="list-style-type: none"> <li>1 Style number</li> <li>2 Paint color number for bookcase and lateral file</li> <li>3 Options, if selected (see below)</li> </ol> <ul style="list-style-type: none"> <li>▶ See <i>Surface Materials</i>, page 506.</li> </ul>
---	--

Options	U.S. Price	Required to Specify
---------	------------	---------------------

<b>Casters</b>	• Casters	+ \$98	Specify with casters.
----------------	-----------	--------	-----------------------

### Specification Information

Style Number	Dimensions			U.S. Base Price
	D	W	H	

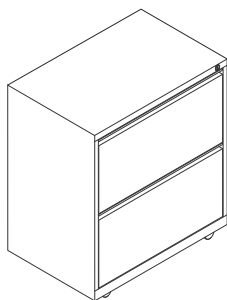
### S-SERIES 1.5-High Bookcase

SSRSSTORAGE	18"	30"	21"	\$698
-------------	-----	-----	-----	-------

### S-SERIES 1.5-High Lateral File with Drawers

SSRSSTORAGE	18"	30"	21"	\$920
-------------	-----	-----	-----	-------

## 2-High Lateral File



Tip: Illustration above shows lateral file with casters.

Tip: S-Series 2-High laterals are only intended for freestanding or mobile applications. Laterals cannot be used under a worksurface or panel-mounted worksurface in fixed applications.

Standard Includes	Required to Specify
-------------------	---------------------

<ul style="list-style-type: none"> <li>▶ Need help? Product details, page 131</li> <li>• 2-high lateral file: paint</li> <li>• Glides</li> <li>• Lock, keyed random</li> </ul>	<ol style="list-style-type: none"> <li>1 Style number</li> <li>2 Paint color number for lateral file</li> <li>3 Options, if selected (see below)</li> </ol> <ul style="list-style-type: none"> <li>▶ See <i>Surface Materials</i>, page 506.</li> </ul>
--	---

Options	U.S. Price	Required to Specify
---------	------------	---------------------

<b>Casters or Glides</b>	• Glides • Hard casters	No cost + \$95	Specify with glides. Specify with casters.
--------------------------	----------------------------	-------------------	---

### Specification Information

Style Number	Dimensions			U.S. Base Price
	D	W	H	

SSFL2H	20"	30"	27 <sup>3</sup> / <sub>8</sub> "	\$891
--------	-----	-----	----------------------------------	-------

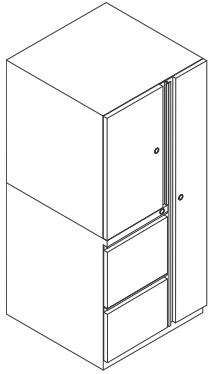


### For Canadian Pricing

Multiply U.S. Price by the Canadian price factor.

▶ See page 1 for details.

**Tower**



**Standard Includes** **Required to Specify**

- |  |  |   |
|--|--|---|
| <ul style="list-style-type: none"> <li>▶ Need help? Product details, page 132</li> </ul> | <ul style="list-style-type: none"> <li>• Tower: paint</li> <li>• Hanger rod and shelves</li> </ul> | <ul style="list-style-type: none"> <li>1 Style number</li> <li>2 Paint color number for tower</li> <li>3 Options, if selected (see below)</li> <li>▶ See <i>Surface Materials</i>, page 506.</li> </ul> |
|--|--|---|

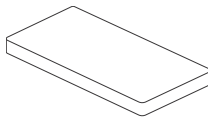
**Options** **U.S. Price** **Required to Specify**

- |                   |   |                    |   |
|-------------------|---|--------------------|---|
| <b>Handedness</b> | <ul style="list-style-type: none"> <li>• Left hinged</li> <li>• Right hinged</li> </ul> | No cost<br>No cost | Specify <i>with left hinged</i> .<br>Specify <i>with right hinged</i> . |
|-------------------|---|--------------------|---|

**Specification Information**

Style Number	Dimensions			U.S. Price
	D	W	H	
SSWTF	24"	24"	53"	\$1846

**Enhanced Pedestal Cushion For Use with 1.5-High and 2-High Pedestals**



*Tip: When 2-High application is selected, only 15"W is available.*

**Standard Includes** **Required to Specify**

- |  |  |   |
|--|--|---|
| <ul style="list-style-type: none"> <li>▶ Need help? Product details, page 133</li> </ul> | <ul style="list-style-type: none"> <li>• 2"H fabric cushion: Billiard</li> <li>• 23"D, if 1.5-High application selected</li> <li>• 19"D, if 2-High application selected</li> </ul> | <ul style="list-style-type: none"> <li>1 Style number</li> <li>2 Specify application</li> <li>3 Fabric color number for cushion</li> <li>4 Options, if selected (see below)</li> <li>▶ See <i>Surface Materials</i>, page 506.</li> </ul> |
|--|--|---|

**Options** **U.S. Price** **Required to Specify**

- |                    |  |                    |  |
|--------------------|--|--------------------|--|
| <b>Width</b>       | <ul style="list-style-type: none"> <li>• 12"</li> <li>• 15"</li> </ul>         | No cost<br>+\$26   | Specify width.<br>Specify width.   |
| <b>Application</b> | <ul style="list-style-type: none"> <li>• 1.5-high</li> <li>• 2-high</li> </ul> | No cost<br>No cost | Specify <i>with 1.5-high application</i> .<br>Specify <i>with 2-high application</i> . |

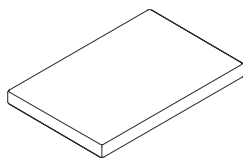
**Specification Information**

Style Number	U.S. Base Price
SSPEDCUSH	\$211



**For Canadian Pricing**  
Multiply U.S. Price by the Canadian price factor.  
▶ See page 1 for details.

## Enhanced Lateral Cushion



Tip: Lateral cushions are only compatible with 2-High laterals.

Standard Includes		Required to Specify
▶ Need help? Product details, page 133	• 20"D x 30"W x 2"H fabric cushion: Billiard	1 Style number 2 Fabric color number for cushion ▶ See <i>Surface Materials</i> , page 506.
Specification Information		
Style Number	U.S. Price	
SSLATCUSH	\$317	

## Core Removal Keys

Tip: Core removal keys must be specified separately to remove lock cores. Removal keys are reusable and do not need to be specified with every furniture order.

Tip: Core removal keys are compatible for S-Series, Revi, Tektis, Embank, and Uptake storage products.

Standard Includes		Required to Specify
	• Core removal keys	Style number
Specification Information		
Style Number	U.S. Price	
SS-CRK	\$23	

## Lock Core and Keys

Tip: Lock core and keys are standard keyed random and are labeled with "PR".

Standard Includes		Required to Specify
	• Lock core and keys	Style number
Specification Information		
Style Number	U.S. Price	
SS-LCK	\$59	



**For Canadian Pricing**  
Multiply U.S. Price by the Canadian price factor.  
▶ See page 1 for details.

## Master Keys

*Tip: Master keys are keyed random.*

Standard Includes	Required to Specify
• Master keys	Style number

### Specification Information

Style Number	U.S. Price
SS-MK	\$23



#### For Canadian Pricing

Multiply U.S. Price by the Canadian price factor.

▶ See page 1 for details.

---

# Work Tools

## **Intro Monitor Arms**

Understanding	<b>141</b>
Specifying	<b>159</b>

## **LED Intro Task Lights**

Understanding	<b>144</b>
Specifying	<b>162</b>

## **Power and Cable Management**

Understanding	<b>147</b>
Specifying	<b>163</b>

## **Slatwall**

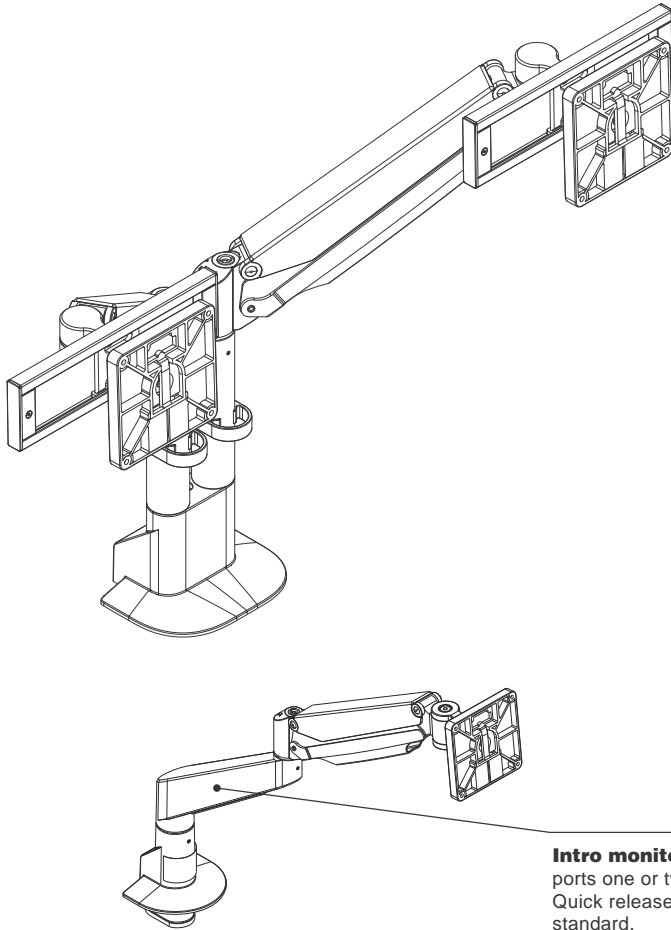
Understanding	<b>150</b>
Specifying	<b>167</b>

# Monitor Arms Specifications



Monitor Support	Up to 30"
Monitor Weight	4.5 – 20 lbs
Monitor Tilt Range	-85° – 15°
Height Adjustment Range	12"
Arm Extension	20"
Arm Retraction	6"
VESA hole sizes	75×75mm / 100×100mm

**Intro display supports** are available in single and dual assembly with universal slider bar tilt heads.



**Intro monitor arm** supports one or two monitors. Quick release tilt head standard.

**Cable management** is included.

*Tip: Monitor arms utilize the VESA hole pattern to connect monitor to arm. Apple monitors do not connect without optional adapter plate. Plate must be acquired through Apple.*

## Product Details

**Intro monitor arms** are standard with 100 VESA plate and tilt head.

**Intro monitor arms** allow for monitor to rotate portrait to landscape orientation.

**Monitor arm assemblies** include mounting bracket options of C-clamp and through-mount.

**Intro single and dual arm brackets** can be C-clamped or through mounted.

**Brackets** are available in desk C-clamp and through-mount.

**All monitor arms** utilize the VESA hole pattern to connect monitor to arm. Apple monitors do not connect without optional adapter plate. Plate must be acquired through Apple.

# Monitor Arm Assemblies and Supports Dimensions

• <b>Features</b>	• <b>Intro Single (AMQCFINTRO)</b>	• <b>Intro Dual with Sliders (AMQCFINTRODLIDE)</b>
-------------------	--	--

Display Supports		
<b>Maximum Monitor Weight</b>	2.2–20 lb	2.2–20 lb per monitor
<b>Maximum Monitor Width</b> (measured left to right)	32"	27"
<b>Maximum Monitor Height</b>	18"	18"
<b>Functional Focal Length*</b>	23.7"	16"
<b>Vertical Adjustment Range</b>	13.2"	13"
<b>Tilt</b> Forward/backward	200°	180°
<b>Lower Arm Rotation</b>	200°	180°
<b>Upper Arm Rotation</b>	360°	360°
<b>Rotation</b> (portrait to landscape)	Yes	Yes
<b>VESA Plate</b>	100 mm	100 mm
<b>VESA Bracket Range</b> (side to side)	180°	180°
<b>Vertical Adjustment Pole Range</b>	N.A.	N.A.

*Tip: Maximum monitor size may be impacted by thickness of monitor and location of VESA bracket mount. Dimensions are estimates.*

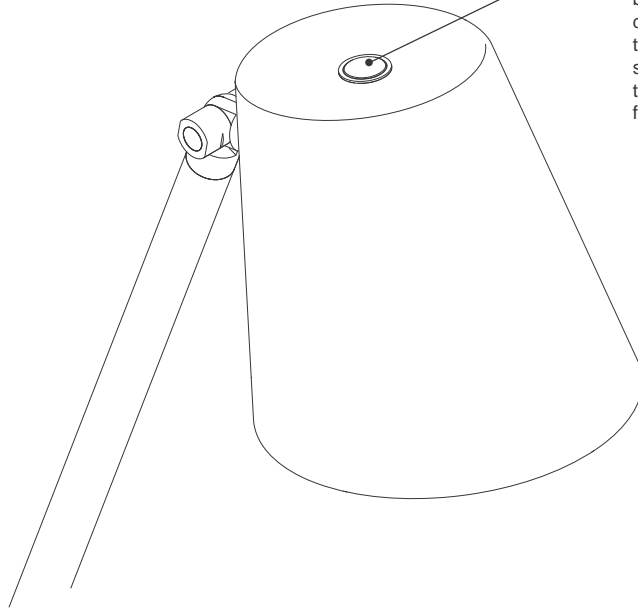
*\*Focal length decreases with larger monitor size.*

*Tip: All monitor arms utilize the VESA hole pattern to connect monitor to arm. Apple monitors do not connect without optional adapter plate. Plate must be acquired through Apple.*



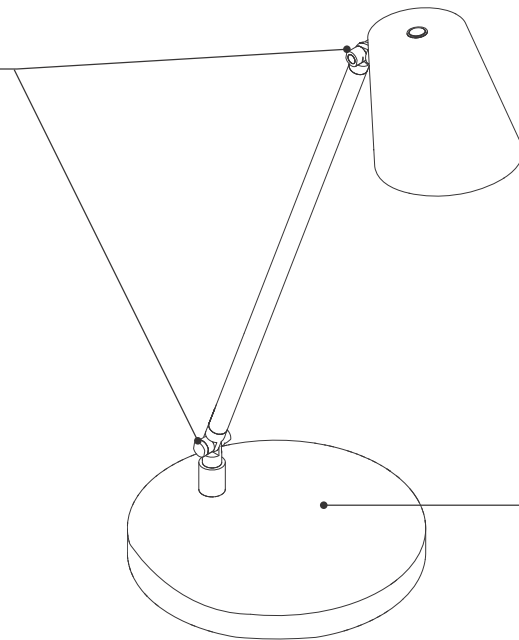
# LED Intro Task Lights

**LED intro task lights** provides ease of user adjustments to direct light where needed, plus a three-step dimming feature. LED light source for energy efficiency.



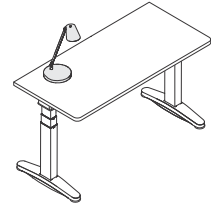
**Capacitive touch switch** is located on the back of the light source with dimming control. The first touch is 10% illumination, second touch is 50%, third touch is 100%, and the fourth touch turns off.

**Light source knuckle and base knuckle** provide articulation points for ease of adjustments to where the light is needed.

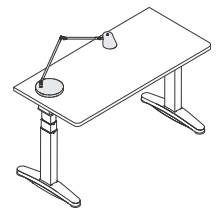


**Freestanding base** is ideal for placing on desk or table tops. Painted to match the entire light fixture and weighted to prevent tipping.

## Product Details



**LED intro single-arm lights** are for use with worksurfaces 58"W or smaller.



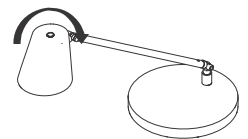
**LED intro double-arm lights** are for use with worksurfaces 60"W or larger.

**LED light performance** with 3000K color temperature and a 90 color rendering index rating.

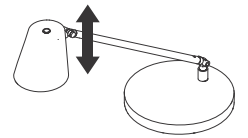
**Adjustability** at the light source and base directs light where needed.

### Examples

- Light head swivels 350° (side to side)



- Light head pivots up and down 180° (up/down)



**Capacitive touch on/off switch and dimming feature** comes standard with three levels: 10%, 50%, and 100%.

**Color temperature of LED** is 3000K.

**Color rendering index (CRI)** is 90.

**Connections**

 Freestanding base

**Wiring & Cabling**

**Light** comes standard with single touch on /10%–50%–100% / off.

**Power supply** uses a modular cord with standard two prong plug, cord length 75".

**Surface Materials**

**Paint**

- 4135 Black Matte
- 4142 Platinum Gloss
- 4143 White Matte

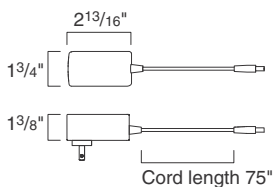
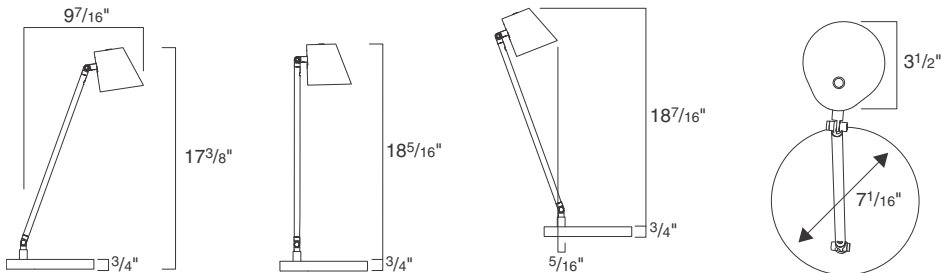
**Application Topics**

**Power cord** length is 75". Consider distance from light to power receptacle, and if surface or under the work-surface power receptacle may be needed.

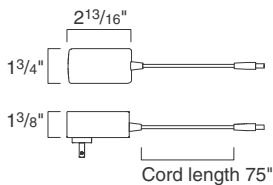
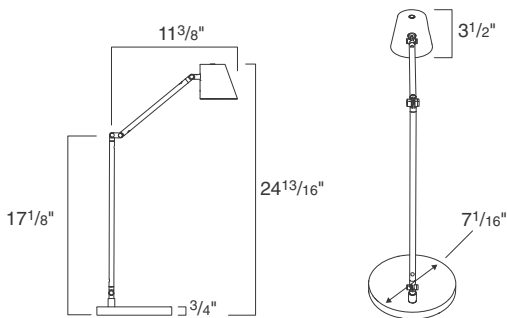
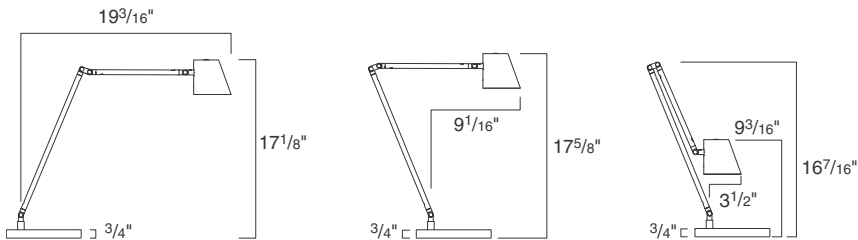
► Pages 147–148

**Actual Dimensions**

**Single Arm**



**Double Arm**

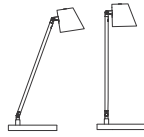


Work Tools

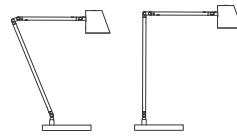
**Task lights** offer end users added control and adjustability to place the proper amount of task lighting to create a holistic work setting.

**LED Lights**

**LED Intro Task Light Single Arm**

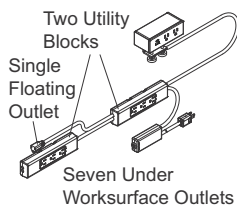
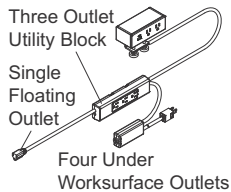
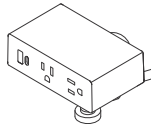


**LED Intro Task Light Double Arm**



<b>Mounting Options</b>	• Freestanding Base	
	Specifying ▶ Page 162	Specifying ▶ Page 162
<b>Watts/Lumens/Efficacy</b>	7 Watts/400 Lumens/62 Efficacy	7 Watts/400 Lumens/62 Efficacy
<b>Color Rendering Index</b>	90	90
<b>Color Temperature</b>	3000K	3000K
<b>Horizontal Arm Range</b>	0"-9 <sup>2</sup> / <sub>5</sub> "	3"-19 <sup>1</sup> / <sub>4</sub> "
<b>Vertical Height Adjustment</b>	17 <sup>2</sup> / <sub>5</sub> "-18 <sup>9</sup> / <sub>20</sub> "	9 <sup>1</sup> / <sub>5</sub> "-24 <sup>4</sup> / <sub>5</sub> "
<b>Tilt/Swivel</b>	<ul style="list-style-type: none"> <li>• Light head pivot – 180° up/down</li> <li>• Swivel – 350°</li> </ul>	<ul style="list-style-type: none"> <li>• Light head pivot – 180° up/down</li> <li>• Swivel – 350°</li> </ul>
<b>Replacement Lamp/Bulb</b>	• Not available	• Not available
<b>Average Rated Lamp Life</b>	• 50,000 hrs.	• 50,000 hrs.
<b>Finish Options</b>	• Paint: Black Matte (4135), Platinum Gloss (4142), or White Matte (4143)	• Paint: Black Matte (4135), Platinum Gloss (4142), or White Matte (4143)
<b>Electronic Dimmer</b>	• Three-step: 10%–50%–100%	• Three-step: 10%–50%–100%
<b>Occupancy Sensor</b>	• Not available	• Not available
<b>Warranty</b>	• 3 year warranty	• 3 year warranty
<b>Power Supply Wattage</b>	• 12 watts	• 12 watts
<b>Power Supply Voltage</b>	• volts	• 24 volts
<b>Cord length</b>	• 75" (6 <sup>1</sup> / <sub>4</sub> )	• 75" (6 <sup>1</sup> / <sub>4</sub> )
<b>Cord material</b>	• Black plastic only	• Black plastic only

## Powerstrip Intro



► Specifying, page 162

## Product Details

**Powerstrip intro** offers two power, one USB-A and one USB-C intelligent 20W with a C-clamp mount for the desktop.

### Desktop power configuration options and specifications include:

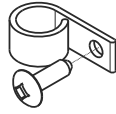
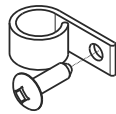
- Two power, one USB-A and one USB-C 20W
- Power outlet is 15A, 120V, 60Hz
- Tamper resistant power outlets

### Meets spill test criteria.

### Two power with 20 watt intelligent USB A+C (3 port):

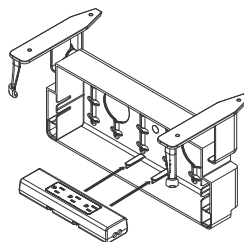
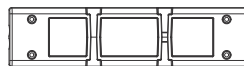
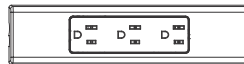
- If only USB-C in use: delivers what the device needs up to 20 watts
- If only USB-A in use, up to 10 watts
- If both USB A+C in use, USB-A delivers up to 10 watts and 10 watts to USB-C. If USB-A device needs less than 10W, the remainder up to 20 watts goes to the USB-C device
- USB-A watt/amp output (2 port) is 10W/2A per port with dedicated charging ports

**Under worksurface optional utility power-blocks** do not ship with independent mounting hardware. They are designed to mount into the universal cable management kit without additional hardware.



**Cable management kit** comes standard with each powerstrip. Mounts under the worksurface to manage cords.

## Optional Under Worksurface Utility Power



**The bottom of each utility powerstrip block** has slots. The slots allow the block to slide onto raised bars in the universal cable management trays. These help keep the powerstrip in place when the tray is opened or closed.

**Universal cable management tray**—small tray holds four outlets and large tray holds seven outlets under worksurface utility power.

## Overcurrent protection via a circuit breaker

prevents one powerstrip intro assembly from drawing more than 15 amps of power.

**Overcurrent protection** is included as standard with powerstrip intro configurations with more than four outlets and is an option on configurations with less than four outlets. Check with your local authorities having jurisdiction to see if overcurrent protection is required for assemblies with less than four outlets.

**Powerstrip intro** includes a 6-foot standard smooth cord with a diameter of 3/8".

**Powerstrip intro** includes a standard straight 3-prong plug. An overcurrent protection (OCP) 90-degree plug is also an option. Check with your local authorities having jurisdiction to see if overcurrent protection is required.

**Overcurrent protection (OCP)** includes a circuit breaker rated for 15 amps.

**C-clamp** is designed to accommodate worksurfaces up to 1 1/2" thick.

## USB A+C 20W



**Powerstrip intro USB ports** are recommended for charging: cell phones, tablets, headphones, wearable fitness trackers, or other small electronic devices. Not recommended for devices needing higher output, more than 20-watts, like compact laptops. See Powerstrip Plus for higher output USB options.

## Surface Materials

### Housing

- 6009 Arctic White

*Tip: Arctic white housing will have white cord.*

## Actual Dimensions

**Depth** 37/16"

**Width** 4 11/16"

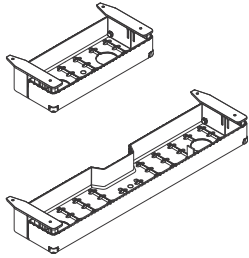
**Height** 1 5/8"

Underwriters Laboratory (UL) Listed. These products have been designed to meet U.S. and Canadian national electrical and energy codes and most local building codes. Local electrical codes vary, so consult with your local authority having jurisdiction as they have final say if the products as installed are compliant with local code.

### Certifications include:

- cULus

**Universal Cable Management Kit**



► Specifying, page 164

**Product Details**

**Universal cable management kit** provides easy management and access to cords, cables, and power blocks under a workstation.

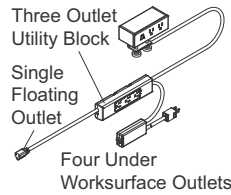
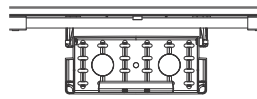
**Optional smart straps** allow for easy management of cables and cords in the cable management tray. Straps are 5<sup>3</sup>/<sub>4</sub>" long.

**Cable management tray** is designed to fit behind the stretcher bar and understructure of most height-adjustable tables.

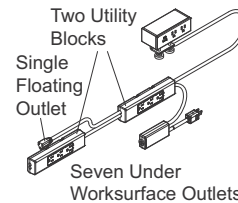
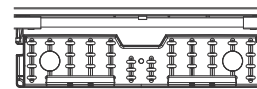
**Cable management tray** provides tool-free and hardware-free mounting of under worksurface utility power.

**Cable management tray** allows for a 4<sup>5</sup>/<sub>8</sub>" gap around all four sides between the tray and the worksurface when mounted to allow for cable egress.

**The small 15<sup>1</sup>/<sub>2</sub>" cable management tray** is designed to hold one, 4 outlet, utility powerstrip. The tray does not have the capacity to hold more than one utility powerstrip.



**The large 30" cable management tray** holds two utility powerstrips in the raised bars section. There is capacity to add three utility powerstrips, two in the raised bar area and one more in the tray, strapped down.



**Surface Materials**

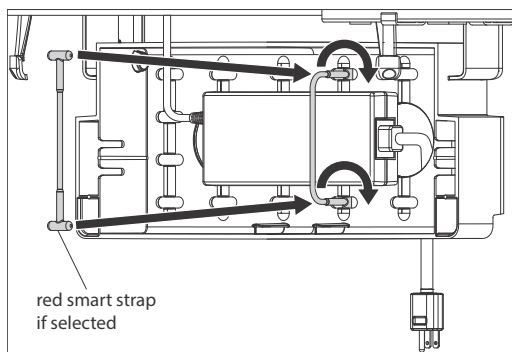
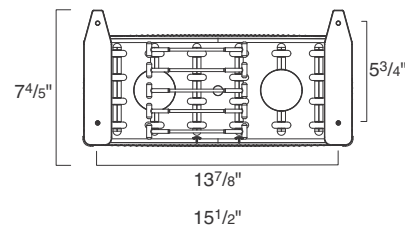
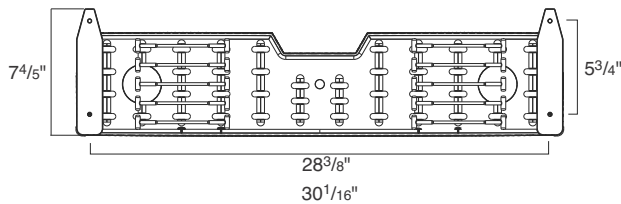
**Cable tray**  
• 6527 Merle

**Actual Dimensions**

**Depth** 6<sup>5</sup>/<sub>16</sub>"  
(7<sup>4</sup>/<sub>8</sub>" with bracket)

**Width** 15<sup>1</sup>/<sub>2</sub>", 30"

**Height** 2<sup>5</sup>/<sub>8</sub>"  
(3<sup>1</sup>/<sub>2</sub>" when installed)



SOTO tool box, utility box, and personal box are not offered individually. Available as bundles only, see page 165.

## SOTO Tool Box



► Specifying, page 165

### Product Details

**SOTO tool box** accommodates pens, pencils, Post-it® notes, and other small office tools.

**SOTO tool box** is standard with a translucent removable dividing insert to keep items separate.

**SOTO tool box** will fit inside c:scape furniture drawers and on shelves.

### Surface Materials

**SOTO tool box**  
• 6009 Arctic White

### Actual Dimensions

**Depth** 3½"

**Width** 3¼"

**Height** 3½"

**Weight** 0.3 lb

## SOTO Utility Box



► Specifying, page 165

### Product Details

**SOTO utility box** is for use on 3" shelf, inside personal box, or on worksurface.

**SOTO utility box** will fit inside c:scape furniture drawers and on shelves.

### Surface Materials

**SOTO utility box**  
• 6009 Arctic White

### Actual Dimensions

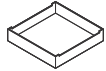
**Depth** 3⅞"

**Width** 9"

**Height** 1¼"

**Weight** 0.3 lb

## SOTO Personal Box



► Specifying, page 165

### Product Details

**SOTO personal box** provides user controlled area for small business or personal items.

**SOTO personal boxes** may be used freestanding or on 10" shelf.

**SOTO personal boxes** may be used individually or stacked horizontal. Boxes interlock when stacked horizontal.

**SOTO storage box set of three** fits neatly inside personal box.

**SOTO personal box** will fit inside c:scape furniture drawers and on shelves.

### Surface Materials

**SOTO personal box**  
• 6009 Arctic White

### Actual Dimensions

**Depth** 9"

**Width** 9"

**Height** 2"

**Weight** 0.3 lb

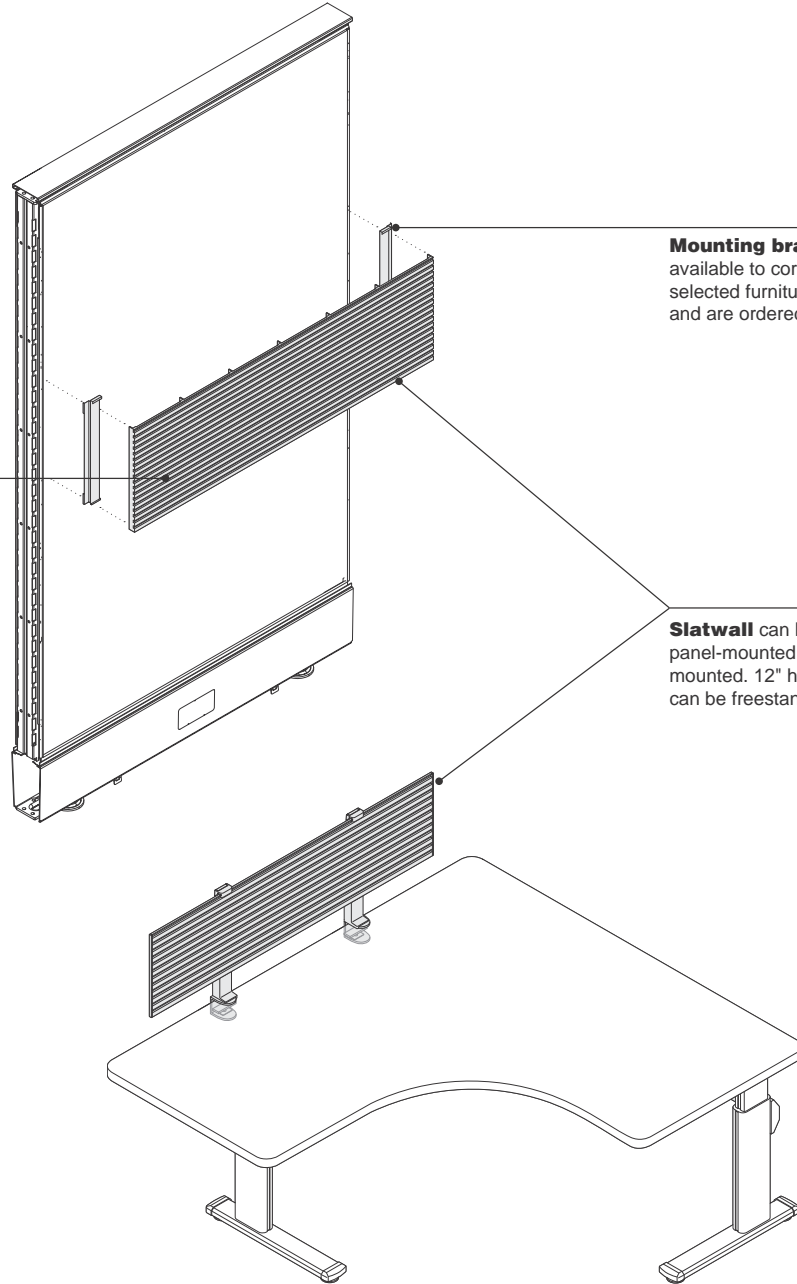
# Slatwall

**Slatwall** allows for vertical stacking anywhere on the tile.  
 ▶ Specifying, page 166

**Slatwall tiles** are standard in 12" or 18" heights and seven different widths.

**Mounting brackets** are available to correspond with selected furniture system and are ordered separately.

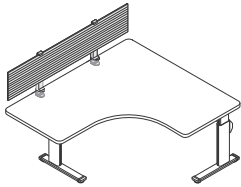
**Slatwall** can be panel-mounted or wall-mounted. 12" high Slatwall can be freestanding.



## Actual Dimensions

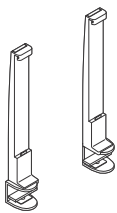
	Freestanding slatwall stanchions	Slatwall tiles	Slatwall brackets
Depth	3"	1/2"	N.A.
Width	3 1/2"	24", 30", 36", 42", 45", 48", or 60"	2"
Height	16"	12" or 18"	12 1/3" or 18"

**Product Details**

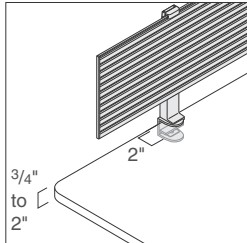


**Slatwall tiles** are available for straight mounting applications only.

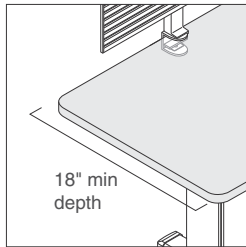
**Slatwall tiles** support a maximum of 60 lb.



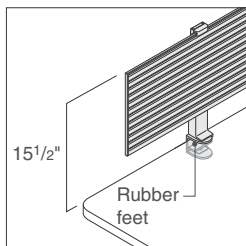
**Freestanding Slatwall stanchions** are for use with 12"H Slatwall tiles only. Stanchions and Slatwall tiles must be ordered separately.



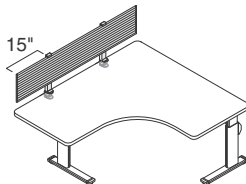
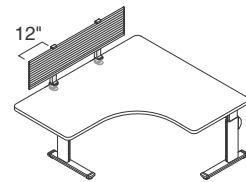
**Freestanding Slatwall stanchions** clamp to work surfaces  $\frac{3}{4}$ " to 2" thick and uses a 2" footprint on the work surface.



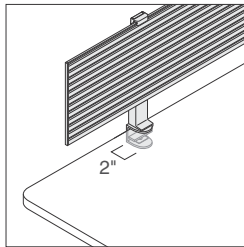
**Worksurface** must be a minimum depth of 18" and able to support a maximum weight of 60 lb when using freestanding Slatwall stanchions.



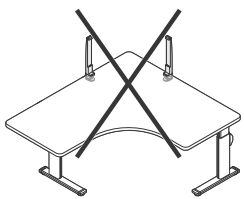
**In freestanding application**, top of Slatwall is 15 $\frac{1}{2}$ " above mounting surface and is a fixed height. Rubber feet under stanchions ensure a tight fit without marring work surface.



**Slatwall** can overhang freestanding stanchions by 12" for tiles 48"W or less and 15" for 60"W tiles.

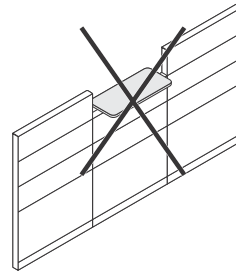


**When using freestanding Slatwall stanchions**, a 2" clearance is required below work surface to accommodate C-clamp.

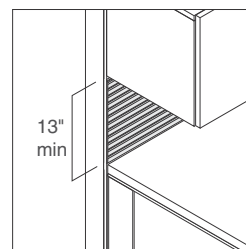


**Freestanding Slatwall stanchions** cannot work in a corner application.

**Freestanding Slatwall stanchions** are not for use with glass, bullnose, knife edge, or other non-standard work surface edges.



**Panel mount Slatwall brackets** cannot be used with transaction top work surfaces.



**Panel or wall-mount applications** require a minimum of 13" vertical space between work surface and overhead bins or shelves.

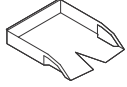
**Wall mount brackets** must be installed in a wall stud.

**Surface Materials**

**Slatwall tiles, stanchions, and brackets**  
• 4799 Platinum

# Freestanding Worktools

## Trays



► Specifying, page 169

### Product Details

**Trays** are available to accommodate letter, legal, and A4 filing.

**Trays** may be used with Slatwall or freestanding applications.

**Trays** are 2½"H and stackable.

**Tray** holds a maximum weight of 7 lb per tray.

**Trays** stack four high on 12"H Slatwall and six high on 18" Slatwall.

### Surface Materials

#### Tray

- 6009 Arctic White
- 6544 Frost

### Actual Dimensions

#### Letter tray

Depth 12½"

Width 10<sup>3</sup>/<sub>16</sub>"

Height 2½"

Weight 1.5 lb

#### Landscape letter tray

Depth 10"

Width 12½"

Height 2½"

Weight 1.5 lb

#### Landscape legal tray

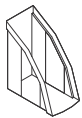
Depth 10"

Width 15½"

Height 2½"

Weight 1.75 lb

## Binder Holder



*Tip: Binder holder requires 9½" of clearance under overhead bins and shelves.*

► Specifying, page 169

### Product Details

**Binder holder** may be used with Slatwall, or freestanding applications.

**Binder holder** mounts in tall orientation for most materials or short orientation for large binders.

**Binder holder** holds a maximum weight of 10 lb and holds up to 4" of materials.

### Surface Materials

#### Binder holder

- 6009 Arctic White
- 6544 Frost

### Actual Dimensions

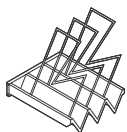
**Depth** 9½"

**Width** 4¾"

**Height** 11¾"

**Weight** 1.2 lb

## PaperFlo Manager



*Tip: PaperFlo Manager requires 11" of clearance under overhead bins and shelves.*

► Specifying, page 170

### Product Details

**PaperFlo Manager** may be used with Slatwall or freestanding applications.

**PaperFlo Manager** is standard with three sloped slots with non-handed wire dividers and sturdy base.

**Blank identification tags** are included.

**PaperFlo Manager** holds a maximum weight of 15 lb.

### Surface Materials

#### PaperFlo Manager

- 6009 Arctic White
- 6544 Frost

### Actual Dimensions

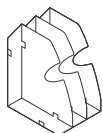
**Depth** 12"

**Width** 9¾"

**Height** 9¾"

**Weight** 2 lb

### Universal Shelves



► Specifying, page 170

#### Product Details

**Universal shelves** are sloped for storing 2<sup>3</sup>/<sub>4</sub>" of materials.

**Universal shelves** may be positioned vertically for letter-size material or horizontally for legal-size material.

**Universal shelves** are available in either a single pack or three pack.

**Universal shelf** holds a maximum weight of 7 lb per shelf.

#### Surface Materials

**Universal shelves**

- 6009 Arctic White
- 6544 Frost

#### Actual Dimensions

**Depth** 9<sup>1</sup>/<sub>2</sub>"

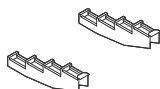
**Width** 2<sup>3</sup>/<sub>4</sub>"

**Height** 12"

**Weight** 0.5 lb

Slatwall Width	Maximum Number of Shelves
24"W	6
30"W	9
36"W	11
42"W	13
45"W	14
48"W	15
60"W	19

### Hanging Brackets



*Tip: Hanging brackets are recommended for use in pairs only. Brackets should not be shared with mounting multiple brackets side by side.*

► Specifying, page 171

#### Product Details

**Hanging brackets** are solid and four stepped for displaying hanging files.

**Hanging brackets** require 6" clearance from top step of bracket to access files under bin and 9" clearance from the bottom step to allow files to hang freely.

#### Surface Materials

**Hanging brackets**

- 6009 Arctic White
- 6544 Frost

#### Actual Dimensions

**Depth** 9<sup>3</sup>/<sub>4</sub>"

**Width** 1<sup>1</sup>/<sub>2</sub>"

**Height** 1<sup>1</sup>/<sub>4</sub>"

**Weight** 1 lb

### Pen/Pencil Cup



► Specifying, page 171

#### Product Details

**Pen/Pencil cup** is 2<sup>3</sup>/<sub>8</sub>" in diameter.

#### Surface Materials

**Pen/Pencil cup**

- 6009 Arctic White
- 6544 Frost

#### Actual Dimensions

**Depth** 4"

**Width** 3<sup>1</sup>/<sub>4</sub>"

**Height** 3<sup>5</sup>/<sub>8</sub>"

**Weight** 0.5 lb

**Double Square Dish**



► Specifying, page 171

**Product Details**

**Double square dish** may be used with Slatwall or freestanding applications.

**Surface Materials**

**Double square dish**

- 6009 Arctic White
- 6544 Frost

**Actual Dimensions**

**Small square**

Depth 27/8"  
Width 25/8"

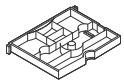
**Large square**

Depth 27/8"  
Width 55/8"

**Outside dimensions**

Depth 4"  
Width 93/4"  
Height 11/2"  
Weight 0.5 lb

**Office in a File**



► Specifying, page 172

**Product Details**

**Office in a File** may be used with Slatwall, hanging brackets, or freestanding applications.

**Office in a File** is portable and standard with seven compartments and translucent cover.

**Office in a File** is standard with built-in tape dispenser.

**Translucent cover** may be used as a writing surface.

**Surface Materials**

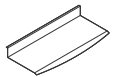
**Office in a File**

- 6009 Arctic White
- 6544 Frost

**Actual Dimensions**

**Depth** 95/8"  
**Width** 121/4"  
**Height** 13/8"  
**Weight** 1.5 lb

**Personal Shelf**



► Specifying, page 172

**Product Details**

**Personal shelf** is standard with raised front edge to prevent items from falling.

**Surface Materials**

**Personal shelf**

- 7018 Pewter

**Actual Dimensions**

**Depth** 71/8"  
**Height** 131/2"  
**Weight** 3 lb

**Telephone Caddy**



*Tip: Telephone caddy is not compatible with Cisco phones.*

► Specifying, page 172

**Product Details**

**Telephone caddy** mounts off desktop at an optimal angle to view numbers and dialing.

**Telephone caddy** is standard with vertical channel for managing telephone cable.

**43/4" clearance** required to mount on Slatwall.

**Surface Materials**

**Telephone caddy**

- 7018 Pewter

**Actual Dimensions**

**Depth** 2"  
**Width** 8"  
**Height** 11"  
**Weight** 6 lb

### Tackstrip



► Specifying, page 173

#### Product Details

**Tackstrip** is a slim tack-able surface for posting reminders or photos.

**Tackstrip surface** is self-filling, reducing the sight of holes from frequent use.

#### Surface Materials

**Tackstrip**  
• 6000 Black

#### Actual Dimensions

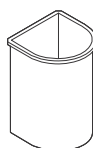
**Depth** 5/16"

**Width** 15"

**Height** 3 1/8"

**Weight** 0.5 lb

### Wastebasket



► Specifying, page 173

#### Product Details

**Wastebasket design** allows wastebasket to hug wall and provide greater foot room underneath worksurface.

**Wastebasket** is made of recycled materials.

**Capacity of wastebasket** is four gallons.

**Recycling labels** are available at no charge and must be ordered separately.

#### Surface Materials

**Wastebasket**  
• 6000 Black

#### Actual Dimensions

**Depth** 10"

**Width** 10"

**Height** 15"

**Weight** 5 lb

### Coat Hook



*Tip: Coat hook is not recommended for use at end of panel run configurations.*

► Specifying, page 173

#### Product Details

**Coat hook** is one piece, solid steel and for use with TEK-TIS.

#### Surface Materials

**Coat hook**  
• 7018 Pewter

#### Actual Dimensions

**Depth** 7/8"

**Width** 2 1/2"

**Height** 2 1/4"

**Weight** 0.15 lb

# LED Linear Shelf Lights

**A properly diffused light source under the linear head** provides a softly blended light pattern that reduces eye strain.  
 ▶ Specifying, page 174

**Optional occupancy sensor** turns off after 30 minutes of no activity and will turn back on upon return.

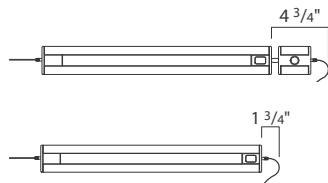
**Magnetic mounts and wood mount bracket hardware**, both come standard with both LED light and optional occupancy sensor.

**Single touch on/off pad plus touch and hold dimming** for easy individual user control.

**Continuous dimming** from 100% to 15% with last state memory.

**Light widths** available in 17", 31", and 44".

**Cord** exits from either end of the light. When needed, allow 1 3/4" cord bend clearance. With optional occupancy sensor, allow additional 4 3/4" clearance from the light fixture.



## Actual Dimensions

	Light	Occupancy Sensor
Depth	2"	2"
Width	17", 31", or 44"	2 3/10"
Height	1/2"	7/10"

**Product Details**

**LED linear stand alone and daisy chain starter lights** include the lamp, power supply, and both magnetic mounts, and wood bracket hardware with adhesive cord managers.

**LED linear daisy chain lights** include the lamp, daisy chain cords, and both magnetic mounts, and wood mount bracket hardware with adhesive cord managers.

**Optional occupancy sensor** is a separate component that connects to the light fixture and activates in 30 minutes when no movement is detected to conserve energy. It will also turn back on upon return.

**Average rated lamp life of LED linear shelf lights** is 50,000 hours.

**Color temperature of LEDs** is 3500K.

**Color rendering index of LEDs** is 92.

**Automatic turn off after 10 hours** (+/- 15 mins.); standard with both models.

**Connections**

**Lights** mount recessed or flush depending on design of overhead storage bin or shelf. Installation is done in the field.

**Magnet mounts** allow shelf lights to be installed without tools under most metal overhead storage bins or shelves.

**Wood mount brackets** allow shelf lights to be mounted to wood shelves.

**Specify** LED linear shelf light for use under 24" wide bins.

Light width	Number of LEDs in Standard Output	System Wattage Standard Output
17"	24	9.1
31"	48	17.6
44"	72	25.9

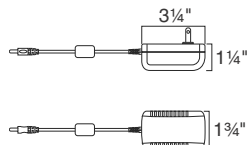
**Wiring & Cabling**

**Light** is standard with single touch on/off and touch control dimming.

**User adjustable touch and hold dimming pad** includes continuous dimming range of 100% to 15%.

**Power supply for 17" linear stand alone only** uses a straight plug with a 9' 18 watt 24 volt wall transformer.

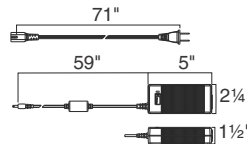
**LED Linear Shelf Light Power Supply Dimensions**



*Tip: Cord length is 9'.*

**Power supply for 31", 44", or 17" starter light;** 65 watt compact in-line brick straight plug. The cord is 11', 6' from power supply to power outlet and 5' from power supply to fixture.

**LED Linear Shelf Light Power Supply Dimensions**



*Tip: Applies to 31", 44", and daisy chained.*

*Tip: Daisy chain starter light comes with a 65 watt power supply to support up to a limited number of lights – refer to chart for daisy chaining fixture. Daisy chain secondary lights do not come with a power supply, but instead come with two daisy chain jumper cords, one 8" and one 30" set.*

▶ See page 158.

**Surface Materials**

- Housing**
  - 4321 Arctic White
  - 0835 Black
- Cord**
  - Black plastic only

**Photometric Data**

**17"W Standard Output Linear Shelf Light** *Measured from 18" above worksurface*

	Worksurface rear							Worksurface front		
12"	10	18	27	31	27	18	11			
6"	15	30	49	59	49	30	15			
CL	18	38	64	79	65	38	19			
8"	16	32	54	65	64	33	17			
12"	12	21	31	37	31	21	12			
	18"	12"	6"	CL	6"	12"	18"			

**31"W Standard Output Linear Shelf Light**

	Worksurface rear							Worksurface front		
12"	25	38	49	53	50	39	26			
6"	41	67	88	95	87	67	42			
CL	50	86	114	125	115	87	52			
8"	43	73	96	104	97	74	45			
12"	29	45	57	62	58	46	30			
	18"	12"	6"	CL	6"	12"	18"			

**44"W Standard Output Linear Shelf Light**

	Worksurface rear							Worksurface front		
12"	42	54	61	63	61	54	42			
6"	73	95	106	109	104	93	72			
CL	94	124	138	141	137	122	94			
8"	80	105	117	121	117	104	80			
12"	50	64	72	75	72	64	50			
	18"	12"	6"	CL	6"	12"	18"			

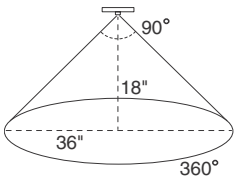
**Chart for Daisy Chaining Fixtures**

Standard Output Linear Shelf Light											
Light fixture widths	Maximum number of fixtures allowed with daisy chain starter light										
	17"	6	4	3	2	2	1	1	-	-	-
31"	-	1	-	2	-	2	1	3	1	1	-
44"	-	-	1	-	-	-	1	-	1	-	2

- A 65 watt power supply is required for daisy chaining.
- Total system wattage of all fixtures together cannot meet or exceed 65 watts, see chart.
- Cannot daisy chain standard output and high output together.
- Cannot daisy chain 58" high output fixtures.
- Occupancy sensor must be positioned between the power supply and the first starter fixture.
- Only need one sensor when daisy chaining.

*Tip: Each column is the maximum number of fixtures that can be daisy chained together.*

**Occupancy Sensor**



- Turns off after 30 minutes of no activity and will turn back on upon return
- 360° lens view
- 90° outward detection angle
- 30" diameter coverage if mounted 15" above worksurface
- 36" diameter coverage if mounted 18" above worksurface
- Connects to fixture with one end-to-end connector. 8" or 30" jumper cords

## ACTIV Eco Power Box



Standard Includes		Required to Specify
<ul style="list-style-type: none"> <li>• Power box with two electrical outlets</li> <li>• Edge mounting clamp</li> <li>• 78" cord</li> <li>• White</li> </ul>		Style number
Specification Information		
Style Number	U.S. Price	
X-E-PB4	\$189	

## ACTIV Boost Power Box



Standard Includes		Required to Specify
<ul style="list-style-type: none"> <li>• Power box with two electrical outlets</li> <li>• Edge mounting clamp</li> <li>• 108" cord</li> <li>• One USB A and one USB C</li> </ul>		Style number
Specification Information		
Style Number	U.S. Price	
BOOSTPOWER	\$403	

## ACTIV Soft Cable Management



Standard Includes		Required to Specify
<ul style="list-style-type: none"> <li>• Felt cable manager with zipper and attachment hardware</li> </ul>		Style number
Specification Information		
Style Number	U.S. Price	
X-FCMT	\$155	

 **For Canadian Pricing**  
 Multiply U.S. Price by the Canadian price factor.  
 ▶ See page 1 for details.

### ILINE Wire Tray



Standard Includes		Required to Specify
<ul style="list-style-type: none"> <li>• Metal tray: paint</li> </ul>		1 Style number 2 Paint color number for metal tray 3 Options, if selected (see below) ▶ See <i>Surface Materials</i> , page 506.

Options	U.S. Price	Required to Specify
<b>Cable Management</b> <ul style="list-style-type: none"> <li>• Wire tray with cable management</li> </ul>	+\$142	Specify <i>with cable management</i> .

Specification Information	
Style Number	U.S. Base Price
ILNEWIRETRAY	\$136

### ACTIV Wire Tray



Standard Includes		Required to Specify
<ul style="list-style-type: none"> <li>• 36"W metal tray: paint</li> <li>• Attachment hardware</li> </ul>		1 Style number 2 Paint color number for metal tray ▶ See <i>Surface Materials</i> , page 506.

Specification Information	
Style Number	U.S. Price
ACTVWIRETRAY	\$128



**For Canadian Pricing**  
 Multiply U.S. Price by the Canadian price factor.  
 ▶ See page 1 for details.

## Single Monitor Arm



Standard Includes	Required to Specify
-------------------	---------------------

- Single monitor arm with VESA plate: paint

- 1 Style number
- 2 Paint color number for arm
- ▶ See *Surface Materials*, page 506.

Specification Information	
Style Number	U.S. Price

Style Number	U.S. Price
<b>MONITORARM</b>	\$302

## Intro Single



Tip: **AMQCFINTRO** supports 2.2–20 lbs. per monitor.

Tip: Standard tilt head is standard with quick release.

Tip: Intro monitor arms come standard with C-clamp and through mount bracket types.

Standard Includes	Required to Specify
-------------------	---------------------

- ▶ Need help? Product details, page 141

- Monitor arm: paint
- Standard tilt head with 100x100 VESA plate

- 1 Style number
- 2 Paint color number for monitor arm
- 3 Options, if selected (see below)
- ▶ See *Surface Materials*, page 506.

Options	U.S. Price	Required to Specify
---------	------------	---------------------

<b>Tilt Head</b>	• Intro standard tilt head	No cost	Specify with Intro standard tilt head.
------------------	----------------------------	---------	--

Specification Information		
Weight	Style Number	U.S. Price

7.6 lbs	<b>AMQCFINTRO</b>	\$397
---------	-------------------	-------



**For Canadian Pricing**  
 Multiply U.S. Price by the Canadian price factor.  
 ▶ See page 1 for details.

## Intro Dual Assembly with Universal Slider Bar Tilt Heads



**Tip: AMQCFINTRODSLIDE** is not recommended for corner applications.

**Tip: AMQCFINTRODSLIDE** is standard with two Universal slider bar tilt heads.

**Tip: AMQCFINTRODSLIDE** supports 2.2-20 lbs. per monitor.

**Tip: Intro monitor arms** come standard with C-clamp and through mount bracket types.

Standard Includes		Required to Specify
<ul style="list-style-type: none"> <li>▶ Need help? Product details, page 141</li> </ul>	<ul style="list-style-type: none"> <li>• Monitor arm: paint</li> <li>• Standard tilt head with 100x100 VESA plate</li> </ul>	<ul style="list-style-type: none"> <li>1 Style number</li> <li>2 Paint color number for monitor arm</li> <li>▶ See <i>Surface Materials</i>, page 506.</li> </ul>

Specification Information		
Weight	Style Number	U.S. Price
13.65 lbs	<b>AMQCFINTRODSLIDE</b>	\$698

## LED Intro Task Lights

Standard Includes		Required to Specify
<ul style="list-style-type: none"> <li>▶ Need help? Product details, page 144</li> </ul>	<ul style="list-style-type: none"> <li>• Task light and freestanding base: paint</li> <li>• 75" cord two-prong power supply</li> <li>• LED light source</li> <li>• Capacitive switch</li> <li>• Three-step dimming</li> <li>• 7W LED 3000K</li> </ul>	<ul style="list-style-type: none"> <li>1 Style number</li> <li>2 Paint color number for task light and freestanding stand</li> <li>▶ See <i>Surface Materials</i>, page 506.</li> </ul>

Specification Information				U.S. Price
Dimensions			Style Number	U.S. Price
D	W	H	Number	

### LED Intro Single-Arm Task Light

7"	7"	18 <sup>3</sup> / <sub>10</sub> "	<b>AMQLSCTSKLIGHT1</b>	\$343
----	----	-----------------------------------	------------------------	-------

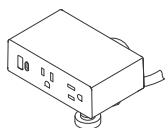
### LED Intro Double-Arm Task Light

7"	7"	17 <sup>3</sup> / <sub>4</sub> "	<b>AMQLSCTSKLIGHT2</b>	\$491
----	----	----------------------------------	------------------------	-------



**Tip: Power cord length is 75".** Consider distance from light to power receptacle, and if surface or under the worksurface power receptacle may be needed. Applies to both single-arm and double-arm lights.

## Powerstrip Intro



*Tip: C-clamp is designed to accommodate worksurfaces up to 1½" thick.*

*Tip: Each USB port can provide up to 10 watts (2 amps).*

*Tip: Overcurrent protection includes a 15 amp circuit breaker.*

*Tip: USB A+C 20W for charging cell phones, tablets, headphones, wearable fitness trackers, or other small electronic devices.*

*Tip: Optional under work-surface utility power blocks do not ship with independent mounting hardware. Designed to be used with the universal cable management kits.*

Standard Includes		Required to Specify
-------------------	--	---------------------

- |  |   |  |
|--|---|--|
| <ul style="list-style-type: none"> <li>▶ Need help? Product details, page 147</li> </ul> | <ul style="list-style-type: none"> <li>• Powerstrip intro: 6009 Arctic White</li> <li>• 6' standard cord</li> <li>• Standard NEMA 5-15 3-prong</li> <li>• 2 power/1 USB-A/1 USB-C 2W</li> <li>• PVC</li> <li>• C-clamp mount</li> </ul> | <ul style="list-style-type: none"> <li>1 Style number</li> <li>2 Options, if selected (see below)</li> </ul> |
|--|---|--|

Options	U.S. Price	Required to Specify
---------	------------	---------------------

- |                      |  |  |  |
|----------------------|--|--|--|
| <b>Utility Power</b> | <ul style="list-style-type: none"> <li>• 1 utility + 1 female plug + tray mount</li> <li>• 2 utility + 1 female plug + tray mount</li> </ul> | <ul style="list-style-type: none"> <li>• +\$158</li> <li>• +\$313</li> </ul> | <ul style="list-style-type: none"> <li>Specify with 1 utility + 1 female plug + tray mount.</li> <li>Specify with 2 utility + 1 female plug + tray mount.</li> </ul> |
|----------------------|--|--|--|

### Specification Information

Dimensions			Style Number	U.S. Base Price
D	W	H		
3"	3"	3½"	<b>AMQDSPINTRO</b>	\$399

Work Tools

 **For Canadian Pricing**  
 Multiply U.S. Price by the Canadian price factor.  
 ▶ See page 1 for details.

## Cable Management Kits

Standard Includes	Required to Specify
<ul style="list-style-type: none"> <li>Need help? Product details, page 148</li> <li>Cable management tray: 6527 Merle</li> <li>Attachment hardware</li> </ul>	Style number

Specification Information				
Dimensions			Style Number	U.S. Price
D	W	H		

### Small Cable Management Kit

6 <sup>5</sup> / <sub>16</sub> "	15 <sup>1</sup> / <sub>2</sub> "	3 <sup>1</sup> / <sub>2</sub> "	<b>AMQDSTRAYSM</b>	\$118
----------------------------------	----------------------------------	---------------------------------	--------------------	-------

### Large Cable Management Kit

6 <sup>5</sup> / <sub>16</sub> "	30"	3 <sup>1</sup> / <sub>2</sub> "	<b>AMQDSTRAYLG</b>	\$158
----------------------------------	-----	---------------------------------	--------------------	-------



*Tip: The weight limit of the 15<sup>1</sup>/<sub>2</sub>" tray is five pounds, while the weight limit of the 30" tray is 10 pounds.*

*Tip: Tray attachment hardware accommodates worksurfaces more than 3/4" in thickness. Screws may pop through thinner worksurfaces.*

*Tip: When installed, tray provides 4/5" of clearance on all sides to allow for cable egress between the underside of the worksurface and the top of the tray.*

## Smart Straps Bulk Pack—For Use with Universal Cable Management Kit

Standard Includes	Required to Specify
<ul style="list-style-type: none"> <li>100 red rubber: smart straps</li> <li>5<sup>1</sup>/<sub>8</sub>" in length</li> </ul>	Style number

Specification Information	
Style Number	U.S. Price
<b>AMQDSBULKSTRP</b>	\$158



**For Canadian Pricing**  
 Multiply U.S. Price by the Canadian price factor.  
 ▶ See page 1 for details.

## SOTO Intro Bundle



*Tip: SOTO intro bundle contains a tool box, personal box, and personal hook.*

Standard Includes	Required to Specify
<ul style="list-style-type: none"> <li>▶ Need help? Product details, page 149</li> <li>• SOTO tool box: 6009 Arctic White</li> <li>• SOTO personal box: 6009 Arctic White</li> <li>• SOTO personal hook: 6009 Arctic White</li> </ul>	Style number

Specification Information	
•Style Number	•U.S. Price
<b>AMQPCDB1</b>	\$135

## SOTO Box Bundle



*Tip: SOTO box bundle contains a tool box, utility box, and personal box.*

Standard Includes	Required to Specify
<ul style="list-style-type: none"> <li>▶ Need help? Product details, page 149</li> <li>• SOTO tool box: 6009 Arctic White</li> <li>• SOTO utility box: 6009 Arctic White</li> <li>• SOTO personal box: 6009 Arctic White</li> </ul>	Style number

Specification Information	
•Style Number	•U.S. Price
<b>AMQPCDB3</b>	\$159

 **For Canadian Pricing**  
 Multiply U.S. Price by the Canadian price factor.  
 ▶ See page 1 for details.

## Freestanding Slatwall Stanchions



Standard Includes	Required to Specify
<ul style="list-style-type: none"> <li>▶ Need help? Product details, page 150</li> <li>• Pair of slatwall stanchions: 4799 Platinum</li> <li>• Non-marring rubber feet</li> </ul>	<ul style="list-style-type: none"> <li>Style number</li> </ul>

Specification Information					
• Dimensions			• Weight	• Style	• U.S.
D	W	H		Number	Price
3"	3½"	16"	3.5 lb	<b>SWALLFS</b>	\$269

*Tip: Position top of Slatwall a fixed height of 15½" above mounting surface.*

*Tip: Slatwall can overhang stanchions up to 12".*

*Tip: For use on worksurfaces ¾" to 2" thick.*

*Tip: Worksurface/table must be able to support 60 lb.*

*Tip: Stanchion cannot be used in a corner application or on a glass surface.*

*Tip: Requires 18"D work-surface and uses 2" surface footprint.*

*Tip: Freestanding Slatwall stanchion is for use with 12"H tiles only.*



**For Canadian Pricing**

Multiply U.S. Price by the Canadian price factor.

▶ See page 1 for details.

## Slatwall Tiles

*Tip: Total dimensions of worktools specified should not exceed slatwall dimensions.*

*Tip: Slatwall is not dedicated to the exact panel width; a 12" overhang is acceptable.*

*Tip: Two slatwall tiles cannot be used in a corner application.*

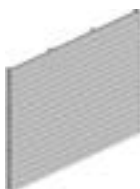
*Tip: Tiles require a minimum worksurface depth of 18" for stability.*

*Tip: A clearance of 2" is required under worksurface to accommodate C-clamp.*

*Tip: Tiles cannot be used on glass, bullnose, knife edge, or other non-standard worksurface edges.*

*Tip: Supports up to 140 lb.*

*Tip: Slatwall is 1/8" shorter than stated without end caps installed.*



Standard Includes	Required to Specify
-------------------	---------------------

▶ Need help? Product details, page 150

- Slatwall tile: 4799 Platinum

Style number

### Specification Information

• Style Number	• Dimensions			• Weight	• U.S. Price
	D	W	H		

### 12"H Slatwall Tiles

SWALLTILE	D	W	H	Weight	U.S. Price
	1/2"	24"	12"	4.5 lb	\$214
	1/2"	30"	12"	5.7 lb	\$242
	1/2"	36"	12"	6.8 lb	\$269
	1/2"	42"	12"	8 lb	\$314
	1/2"	45"	12"	8.5 lb	\$333
	1/2"	48"	12"	9.1 lb	\$359
	1/2"	60"	12"	11.4 lb	\$445

### 18"H Slatwall Tiles

SWALLTILE	D	W	H	Weight	U.S. Price
	1 1/8"	24"	18"	4.04 lb	\$452
	1 1/8"	30"	18"	11.5 lb	\$518
	1 1/8"	36"	18"	13.16 lb	\$580
	1 1/8"	42"	18"	15.62 lb	\$638
	1 1/8"	45"	18"	16.5 lb	\$702
	1 1/8"	48"	18"	17.28 lb	\$767
	1 1/8"	60"	18"	19 lb	\$830



**For Canadian Pricing**

Multiply U.S. Price by the Canadian price factor.

▶ See page 1 for details.

## Panel-Mount Brackets



Tip: Brackets for use with 42"H panels cannot be used with transaction top worksurfaces.

Tip: **SWALLPM42** positions the slatwall tile in the top position on the panel. Use this bracket with TEKTIS 42"H panels.

Standard Includes		Required to Specify		
▶ Need help? Product details, page 150	• Pair of slatwall brackets: 4799 Platinum	Style number		
Specification Information				
Dimensions		Weight	Style	U.S.
W	H		Number	Price
<b>12"H Panel-Mount Brackets</b>				
<b>For Use with TEKTIS</b>				
2"	12 <sup>1</sup> / <sub>3</sub> "	2 lb	<b>SWALLPM</b>	\$ 69
<b>For Use with TEKTIS 42"H Panels</b>				
2"	12 <sup>1</sup> / <sub>3</sub> "	2 lb	<b>SWALLPM42</b>	\$133
<b>18"H Panel-Mount Brackets</b>				
<b>For Use with TEKTIS</b>				
2"	18"	3.5 lb	<b>SWALLPM</b>	\$193

## Wall-Mount Brackets



Tip: Wall-mount brackets must be mounted to a wall stud.

Standard Includes		Required to Specify		
▶ Need help? Product details, page 150	• Pair of slatwall brackets: 4799 Platinum	Style number		
Specification Information				
Dimensions		Weight	Style	U.S.
W	H		Number	Price
<b>12"H Wall-Mount Brackets</b>				
2"	12 <sup>1</sup> / <sub>3</sub> "	2 lb	<b>SWALLWM</b>	\$ 64
<b>18"H Wall-Mount Brackets</b>				
2"	18"	3.5 lb	<b>SWALLWM</b>	\$193



**For Canadian Pricing**  
Multiply U.S. Price by the Canadian price factor.  
▶ See page 1 for details.

## File Trays

*Tip: Trays do not interlock when installed on slatwall.*

Standard Includes	Required to Specify
-------------------	---------------------

- |  |   |   |
|--|---|---|
| <ul style="list-style-type: none"> <li>▶ Need help? Product details, page 152</li> </ul> | <ul style="list-style-type: none"> <li>• Tray: 6009 Arctic White or 6544 Frost</li> </ul> | <ul style="list-style-type: none"> <li>1 Style number</li> <li>2 Plastic color number for tray</li> </ul> |
|--|---|---|

Specification Information					
Dimensions			Weight	Style Number	U.S. Price
D	W	H			

### Portrait Letter Tray

12½"	10¾"	2½"	1.5 lb	<b>SWALLTRAY</b>	\$69
------	------	-----	--------	------------------	------

### Landscape Letter Tray

10"	12½"	2½"	1.5 lb	<b>SWALLTRAY</b>	\$69
-----	------	-----	--------	------------------	------

### Landscape Legal Tray

10"	15½"	2½"	1.75 lb	<b>SWALLTRAY</b>	\$69
-----	------	-----	---------	------------------	------



## Binder Holder

Standard Includes	Required to Specify
-------------------	---------------------

- |  |  |  |
|--|--|--|
| <ul style="list-style-type: none"> <li>▶ Need help? Product details, page 152</li> </ul> | <ul style="list-style-type: none"> <li>• Binder holder: 6009 Arctic White or 6544 Frost</li> </ul> | <ul style="list-style-type: none"> <li>1 Style number</li> <li>2 Plastic color number for binder holder</li> </ul> |
|--|--|--|

Specification Information					
Dimensions			Weight	Style Number	U.S. Price
D	W	H			

9⅛"	4¾"	11⅜"	1.2 lb	<b>SWALLBH</b>	\$69
-----	-----	------	--------	----------------	------



*Tip: Binder holder requires 9½"H clearance under bins or shelves.*

 **For Canadian Pricing**  
 Multiply U.S. Price by the Canadian price factor.  
 ▶ See page 1 for details.

## PaperFlo Manager



Tip: PaperFlo manager requires 11" clearance under bins.

Standard Includes	Required to Specify
-------------------	---------------------

- |  |   |   |
|--|---|---|
| <ul style="list-style-type: none"> <li>▶ Need help? Product details, page 152</li> </ul> | <ul style="list-style-type: none"> <li>• PaperFlo manager: 6009 Arctic White or 6544 Frost</li> </ul> | <ul style="list-style-type: none"> <li>1 Style number</li> <li>2 Plastic color number for PaperFlo manager</li> </ul> |
|--|---|---|

Specification Information					
Dimensions			Weight	Style Number	U.S. Price
D	W	H			

12"	9¾"	9¾"	2 lb	<b>SWALLPF</b>	\$167
-----	-----	-----	------	----------------	-------

## Universal Shelves



Tip: Shelves do not interlock when installed on Slatwall.

Standard Includes	Required to Specify
-------------------	---------------------

- |  |  |  |
|--|--|--|
| <ul style="list-style-type: none"> <li>▶ Need help? Product details, page 153</li> </ul> | <ul style="list-style-type: none"> <li>• Shell: 6009 Arctic White or 6544 Frost</li> </ul> | <ul style="list-style-type: none"> <li>1 Style number</li> <li>2 Plastic color number for shell</li> </ul> |
|--|--|--|

Specification Information					
Dimensions			Weight	Style Number	U.S. Price
D	W	H			

9½"	2¾"	12"	0.5 lb	<b>SWALLUS</b>	\$ 40
-----	-----	-----	--------	----------------	-------

### Universal Shelves—Single Pack

9½"	2¾"	12"	0.5 lb	<b>SWALLUS</b>	\$ 40
-----	-----	-----	--------	----------------	-------

### Universal Shelves—Three Pack

9½"	2¾"	12"	1.5 lb	<b>SWALLUS3</b>	\$119
-----	-----	-----	--------	-----------------	-------

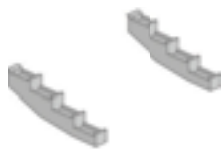


### For Canadian Pricing

Multiply U.S. Price by the Canadian price factor.

▶ See page 1 for details.

## Hanging Brackets



*Tip: Hanging brackets require 6" clearance from top step of bracket to access files under bin and a 9" clearance from the bottom step to the top of worksurface to allow files to hang freely.*

*Tip: Hanging brackets are recommended using in pairs only. Brackets should not be shared when mounting multiple brackets side by side.*

Standard Includes	Required to Specify
-------------------	---------------------

- |  |   |   |
|--|---|---|
| ▶ Need help? Product details, page 153 | <ul style="list-style-type: none"> <li>• Hanging brackets: 6009 Arctic White or 6544 Frost</li> </ul> | 1 Style number<br>2 Plastic color number for hanging brackets |
|--|---|---|

Specification Information					
Dimensions			Weight	Style Number	U.S. Price
D	W	H			

9¾"	1½"	1¼"	1 lb	<b>SWALLHB</b>	\$69
-----	-----	-----	------	----------------	------

## Pen/Pencil Cup



Standard Includes	Required to Specify
-------------------	---------------------

- |  |   |   |
|--|---|---|
| ▶ Need help? Product details, page 153 | <ul style="list-style-type: none"> <li>• Pen/pencil cup: 6009 Arctic White or 6544 Frost</li> </ul> | 1 Style number<br>2 Plastic color number for pen/pencil cup |
|--|---|---|

Specification Information					
Dimensions			Weight	Style Number	U.S. Price
D	W	H			

4"	3¼"	3⅝"	0.5 lb	<b>SWALLCUP</b>	\$69
----	-----	-----	--------	-----------------	------

## Double Square Dish



Standard Includes	Required to Specify
-------------------	---------------------

- |  |   |   |
|--|---|---|
| ▶ Need help? Product details, page 154 | <ul style="list-style-type: none"> <li>• Dish: 6009 Arctic White or 6544 Frost</li> <li>• Attachment bracket</li> </ul> | 1 Style number<br>2 Plastic color number for dish |
|--|---|---|

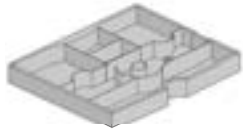
Specification Information					
Dimensions			Weight	Style Number	U.S. Price
D	W	H			

4"	9¾"	1½"	0.5 lb	<b>SWALLDISH</b>	\$69
----	-----	-----	--------	------------------	------



**For Canadian Pricing**  
 Multiply U.S. Price by the Canadian price factor.  
 ▶ See page 1 for details.

### Office in a File



Standard Includes	Required to Specify
-------------------	---------------------

- |  |   |   |
|--|---|---|
| <ul style="list-style-type: none"> <li>▶ Need help? Product details, page 154</li> </ul> | <ul style="list-style-type: none"> <li>• Storage file: 6009 Arctic White or 6544 Frost</li> <li>• Built-in tape dispenser</li> <li>• Translucent cover</li> </ul> | <ul style="list-style-type: none"> <li>1 Style number</li> <li>2 Plastic color number for storage file</li> </ul> |
|--|---|---|

Specification Information					
Dimensions			Weight	Style Number	U.S. Price
D	W	H			

9 5/8"	12 1/4"	1 3/8"	1.5 lb	<b>SWALLOF</b>	\$69
:	:	:	:	:	:

### Personal Shelf



Standard Includes	Required to Specify
-------------------	---------------------

- |  |   |  |
|--|---|--|
| <ul style="list-style-type: none"> <li>▶ Need help? Product details, page 154</li> </ul> | <ul style="list-style-type: none"> <li>• Personal shelf: 7018 Pewter</li> </ul> | <ul style="list-style-type: none"> <li>Style number</li> </ul> |
|--|---|--|

Specification Information				
Dimensions		Weight	Style Number	U.S. Price
D	W			

7 1/8"	13 1/2"	3 lb	<b>SWALLPS</b>	\$76
:	:	:	:	:

### Telephone Caddy



Standard Includes	Required to Specify
-------------------	---------------------

- |  |  |  |
|--|--|--|
| <ul style="list-style-type: none"> <li>▶ Need help? Product details, page 154</li> </ul> | <ul style="list-style-type: none"> <li>• Telephone caddy: 7018 Pewter</li> </ul> | <ul style="list-style-type: none"> <li>Style number</li> </ul> |
|--|--|--|

Specification Information					
Dimensions			Weight	Style Number	U.S. Price
D	W	H			

2"	8"	11"	6 lb	<b>SWALLTC</b>	\$168
:	:	:	:	:	:



**For Canadian Pricing**  
 Multiply U.S. Price by the Canadian price factor.  
 ▶ See page 1 for details.

## Tackstrip



Standard Includes		Required to Specify
▶ Need help? Product details, page 155	• Tackstrip: 6000 Black	Style number

Specification Information					
Dimensions			Weight	Style Number	U.S. Price
D	W	H			
5/16"	15"	3 1/8"	0.5 lb	<b>SWALLTACK</b>	\$79

## Wastebasket



Standard Includes		Required to Specify
▶ Need help? Product details, page 155	• Wastebasket: 6000 Black	Style number

Specification Information					
Dimensions			Weight	Style Number	U.S. Price
D	W	H			
10"	10"	15"	5 lb	<b>SWALLWB</b>	\$76

## Coat Hook



Standard Includes		Required to Specify
▶ Need help? Product details, page 155	• Coat hook: 7018 Pewter	Style number

Specification Information					
Dimensions			Weight	Style Number	U.S. Price
D	W	H			
7/8"	2 1/2"	2 1/4"	0.15 lb	<b>SWALLHOOK</b>	\$31

*Tip: Coat hook not recommended for use at end of panel run configurations.*

*Tip: Maximum weight for coat hook is 10 lb.*



**For Canadian Pricing**  
 Multiply U.S. Price by the Canadian price factor.  
 ▶ See page 1 for details.

## Shelf Lights



*Tip: The power supply for the 17" stand alone only uses a straight plug with a 9' 18 watt 24 volt transformer. The power supply for the 31" or 44" starter light uses a 11' 65 watt compact in-line brick with straight plug.*

*Tip: Cord exists on ends of light fixture. Allow 1<sup>3</sup>/<sub>4</sub>" cord bend radius. With optional occupancy sensor, add 4<sup>3</sup>/<sub>4</sub>".*

Standard Includes	Required to Specify
-------------------	---------------------

- |  |   |   |
|--|---|---|
| <ul style="list-style-type: none"> <li>▶ Need help? Product details, page 156</li> </ul> | <ul style="list-style-type: none"> <li>• Task light and mounting bracket: paint price group 1</li> <li>• Standard output</li> <li>• Power supply with cord: black</li> <li>• Soft touch switch</li> <li>• Magnetic and wood mounting brackets</li> <li>• Continuous range dimmer</li> <li>• Automatic turn off program</li> <li>• Color temperature: 3500K</li> </ul> | <ul style="list-style-type: none"> <li>1 Style number</li> <li>2 Paint color number for task light and mounting bracket</li> <li>3 Options, if selected (see below)</li> <li>▶ See <i>Surface Materials</i>, page 506.</li> </ul> |
|--|---|---|

Options	U.S. Price	Required to Specify
---------	------------	---------------------

- |  |   |   |
|--|---|---|
| <b>Surface Materials</b> <ul style="list-style-type: none"> <li>• Paint price group 1</li> <li>• Paint price group 2</li> </ul>  | <ul style="list-style-type: none"> <li>No cost</li> <li>+\$ 17</li> </ul> | <ul style="list-style-type: none"> <li>Specify paint color number.</li> <li>Specify paint color number.</li> </ul>                        |
| <b>Occupancy Sensor</b> <ul style="list-style-type: none"> <li>• No occupancy sensor</li> <li>• With occupancy sensor</li> </ul> | <ul style="list-style-type: none"> <li>No cost</li> <li>+\$175</li> </ul> | <ul style="list-style-type: none"> <li>Specify <i>with no occupancy sensor</i>.</li> <li>Specify <i>with occupancy sensor</i>.</li> </ul> |

Specification Information				
Dimensions			Style	U.S.
D	W	H	Number	Base Price

:	:	:	:	:
---	---	---	---	---

### LED Linear 17" Stand Alone Shelf Light

2"	17"	7/10"	<b>UBLIGHT17</b>	\$360
:	:	:	:	:

### LED Linear 31" Stand Alone or Daisy Chain Starter Shelf Light

2"	31"	7/10"	<b>UBLIGHT31</b>	\$581
:	:	:	:	:

### LED Linear 44" Stand Alone or Daisy Chain Starter Shelf Light

2"	44"	7/10"	<b>UBLIGHT44</b>	\$772
:	:	:	:	:



#### For Canadian Pricing

Multiply U.S. Price by the Canadian price factor.

▶ See page 1 for details.

---

# TEKTIS

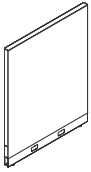
	
<b>Statement of Line</b>	<b>176</b>

	
<b>TEKTIS</b>	
Understanding	<b>190</b>
Specifying	<b>241</b>

	
<b>Surface Materials</b>	<b>287</b>
<b>Resources</b>	<b>379</b>

# Statement of Line

## Monolithic Panels

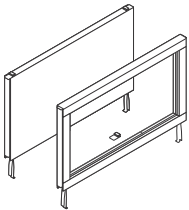


Understanding  
 ▶ Page 190  
 Specifying  
 ▶ Page 241

## Monolithic Panels

	24"W	30"W	36"W	42"W	48"W	60"W
42"H	●	●	●	●	●	●
48"H	●	●	●	●	●	●
54"H	●	●	●	●	●	●
66"H	●	●	●	●	●	●

## Panel Stackers

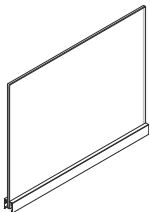


Understanding  
 ▶ Page 192  
 Specifying  
 ▶ Pages 242 and 244

## Panel Stackers

	24"W	30"W	36"W	42"W	48"W	60"W	72"W
12"H	●	●	●	●	●	●	●
18"H	●	●	●	●	●	●	●
24"H	●	●	●	●	●	●	●

## Frameless Glass Stackers



Understanding  
 ▶ Page 194  
 Specifying  
 ▶ Page 243

## Frameless Glass Stackers

	24"W	30"W	36"W	42"W	48"W	60"W
6"H	●	●	●	●	●	●
12"H	●	●	●	●	●	●
18"H	●	●	●	●	●	●

## Panel Trim



Understanding  
 ▶ Page 196  
 Specifying  
 ▶ Page 245



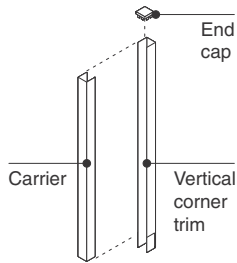
Understanding  
 ▶ Page 196  
 Specifying  
 ▶ Page 246

### Vertical End-of-Run Trim

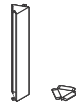
	42"H	48"H	54"H	60"H	66"H	72"H	78"H
Standard	●	●	●	●	●	●	●

### Change-of-Height Trim

	6"H	12"H	18"H	24"H	36"H
Standard	●	●	●	●	●



Understanding  
 ▶ Page 196  
 Specifying  
 ▶ Page 247



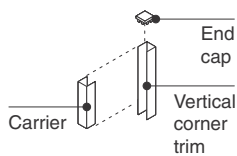
Understanding  
 ▶ Page 196  
 Specifying  
 ▶ Page 248

### Vertical Corner Trims

	42"H	48"H	54"H	66"H
Standard	●	●	●	●

### 120° Vertical Corner Trims

	42"H	48"H	54"H	66"H
Standard	●	●	●	●

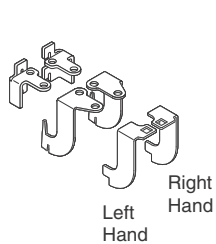


Understanding  
 ▶ Page 196  
 Specifying  
 ▶ Page 249

### Vertical Corner Change-of-Height Trims

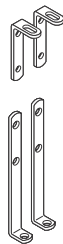
	6"H	12"H	18"H	24"H
Standard	●	●	●	●

## Panel Connectors



### **Change-of-Height In-Line and Corner Panel Connector Package**

Understanding  
▶ Page 198  
Specifying  
▶ Page 252



### **Wall Start Connector Package**

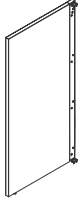
Understanding  
▶ Page 198  
Specifying  
▶ Page 252



### **120° Connectors**

Understanding  
▶ Page 198  
Specifying  
▶ Page 252

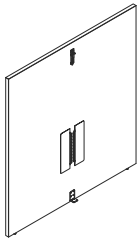
## Boundary Screens



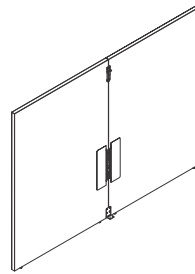
Understanding  
 ▶ Page 236  
 Specifying  
 ▶ Page 278

### End-of-Run Boundary Screen—Single-Sided

	24"W	30"W	36"W	42"W	48"W	54"W	60"W	66"W	72"W
42"H	●	●	●	●	●	●	●	●	●
48"H	●	●	●	●	●	●	●	●	●
54"H	●	●	●	●	●	●	●	●	●



Understanding  
 ▶ Page 236  
 Specifying  
 ▶ Page 278



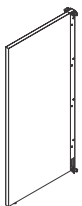
Understanding  
 ▶ Page 236  
 Specifying  
 ▶ Page 278

### End-of-Run Boundary Screen—Spanning

	48"W	60"W	72"W
28½"H	●	●	●
42"H	●	●	●
48"H	●	●	●
54"H	●	●	●

### End-of-Run Boundary Screen—Split

	36"W	42"W	48"W	54"W	60"W	66"W	72"W
28½"H	●	●	●	●	●	●	●
42"H	●	●	●	●	●	●	●
48"H	●	●	●	●	●	●	●
54"H	●	●	●	●	●	●	●

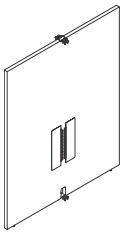


Understanding  
 ▶ Page 236  
 Specifying  
 ▶ Page 280

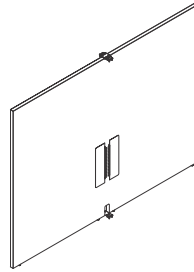
### Middle-of-Run Boundary Screen—Single-Sided

	24"W	30"W	36"W	42"W	48"W	54"W	60"W	66"W	72"W
42"H	●	●	●	●	●	●	●	●	●
48"H	●	●	●	●	●	●	●	●	●
54"H	●	●	●	●	●	●	●	●	●

**Boundary Screens, continued**



Understanding  
 ▶ Page 236  
 Specifying  
 ▶ Page 280



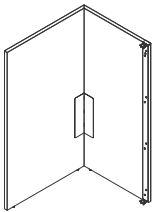
Understanding  
 ▶ Page 236  
 Specifying  
 ▶ Page 280

**Middle-of-Run Boundary Screen—Spanning**

	48"W	60"W	72"W
42"H	●	●	●
48"H	●	●	●
54"H	●	●	●

**Middle-of-Run Boundary Screen—Split**

	36"W	42"W	48"W	54"W	60"W	66"W	72"W
42"H	●	●	●	●	●	●	●
48"H	●	●	●	●	●	●	●
54"H	●	●	●	●	●	●	●



Understanding  
 ▶ Page 236  
 Specifying  
 ▶ Page 282

**L Return End-of-Run Boundary Screen—Single-Sided (Primary Screen)**

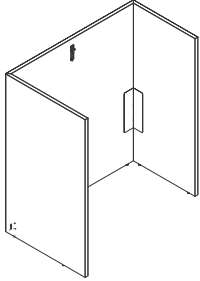
	24"W	30"W	36"W	42"W	48"W	54"W	60"W	66"W	72"W
42"H	●	●	●	●	●	●	●	●	●
48"H	●	●	●	●	●	●	●	●	●
54"H	●	●	●	●	●	●	●	●	●

Understanding  
 ▶ Page 236  
 Specifying  
 ▶ Page 282

**L Return End-of-Run Boundary Screen—Single-Sided (Return Screen)**

	24"W	30"W
42"H	●	●
48"H	●	●
54"H	●	●

**Boundary Screens, continued**



Understanding  
 ▶ Page 236  
 Specifying  
 ▶ Page 284

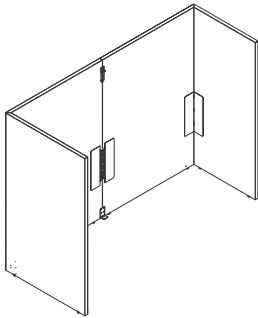
Understanding  
 ▶ Page 236  
 Specifying  
 ▶ Page 284

**L Return End-of-Run Boundary Screen—Spanning (Primary Screen)**

	48"W	60"W	72"W
28½"H	●	●	●
42"H	●	●	●
48"H	●	●	●
54"H	●	●	●

**L Return End-of-Run Boundary Screen—Spanning (Return Screen)**

	24"W	30"W
28½"H	●	●
42"H	●	●
48"H	●	●
54"H	●	●



Understanding  
 ▶ Page 236  
 Specifying  
 ▶ Page 284

Understanding  
 ▶ Page 236  
 Specifying  
 ▶ Page 284

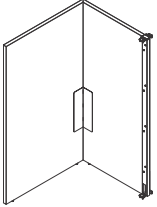
**L Return End-of-Run Boundary Screen—Split (Primary Screen)**

	42"W	48"W	54"W	60"W	66"W	72"W
28½"H	●	●	●	●	●	●
42"H	●	●	●	●	●	●
48"H	●	●	●	●	●	●
54"H	●	●	●	●	●	●

**L Return End-of-Run Boundary Screen—Split (Return Screen)**

	24"W	30"W
28½"H	●	●
42"H	●	●
48"H	●	●
54"H	●	●

**Boundary Screens, continued**



Understanding  
 ▶ Page 236  
 Specifying  
 ▶ Page 284

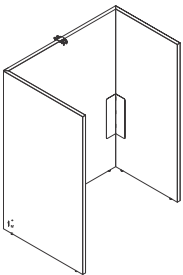
**L Return Middle-of-Run Boundary Screen—Single-Sided (Primary Screen)**

	24"W	30"W	36"W	42"W	48"W	54"W	60"W	66"W	72"W
42"H	●	●	●	●	●	●	●	●	●
48"H	●	●	●	●	●	●	●	●	●
54"H	●	●	●	●	●	●	●	●	●

Understanding  
 ▶ Page 236  
 Specifying  
 ▶ Page 284

**L Return Middle-of-Run Boundary Screen—Single-Sided (Return Screen)**

	24"W	30"W
42"H	●	●
48"H	●	●
54"H	●	●



Understanding  
 ▶ Page 236  
 Specifying  
 ▶ Page 284

Understanding  
 ▶ Page 236  
 Specifying  
 ▶ Page 284

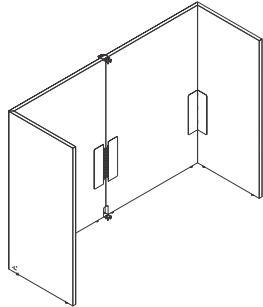
**L Return Middle-of-Run Boundary Screens—Spanning (Primary Screen)**

	48"W	60"W	72"W
42"H	●	●	●
48"H	●	●	●
54"H	●	●	●

**L Return Middle-of-Run Boundary Screen—Spanning (Return Screen)**

	24"W	30"W
42"H	●	●
48"H	●	●
54"H	●	●

**Boundary Screens, continued**



Understanding  
 ▶ Page 236  
 Specifying  
 ▶ Page 284

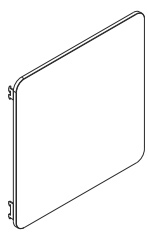
Understanding  
 ▶ Page 236  
 Specifying  
 ▶ Page 284

**L Return Middle-of-Run Boundary Screen—  
 Split (Primary Screen)**

	36"W	42"W	48"W	54"W	60"W	66"W	72"W
42"H	●	●	●	●	●	●	●
48"H	●	●	●	●	●	●	●
54"H	●	●	●	●	●	●	●

**L Return Middle-of-Run Boundary Screen—  
 Split (Return Screen)**

	24"W	30"W
42"H	●	●
48"H	●	●
54"H	●	●



Understanding  
 ▶ Page 240  
 Specifying  
 ▶ Page 286

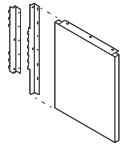
**Hanging Markerboard**

	24"W	30"W	36"W	42"W	48"W	60"W
24"H	●	●	●	●	●	●

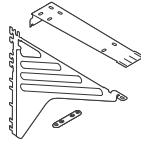
## Worksurface Legs and Supports



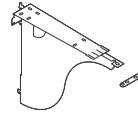
**Post Leg**  
 Understanding  
 ▶ Page 226  
 Specifying  
 ▶ Page 254



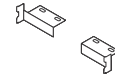
**On-Module End Panel**  
 Understanding  
 ▶ Page 226  
 Specifying  
 ▶ Page 254



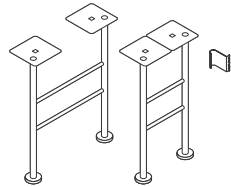
**Universal Cantilever**  
 Understanding  
 ▶ Page 226  
 Specifying  
 ▶ Page 254



**Cantilever with Tie Plate**  
 Understanding  
 ▶ Page 226  
 Specifying  
 ▶ Page 254



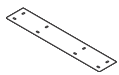
**Side Support Brackets to Connect Worksurface to Panel**  
 Understanding  
 ▶ Page 226  
 Specifying  
 ▶ Page 254



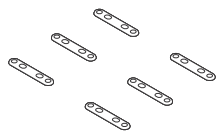
H-leg with bracket

**H-Leg with Bracket**  
 Understanding  
 ▶ Page 226  
 Specifying  
 ▶ Page 254

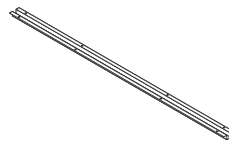
## TEKTIS and EMBANK Shared Accessories



**In-Line Support Plates**  
 Understanding  
 ▶ Page 226  
 Specifying  
 ▶ Page 377

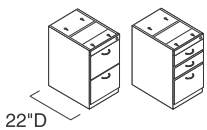


**Package of Six Tie Plates for Side-by-Side Worksurfaces**  
 Understanding  
 ▶ Page 226  
 Specifying  
 ▶ Page 377



**Reinforcing Channels**  
 Understanding  
 ▶ Page 226  
 Specifying  
 ▶ Page 377

## Fixed Pedestals



22"D

28"D

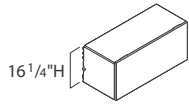
Understanding  
 ▶ Page 230  
 Specifying  
 ▶ Page 256

## Fixed Pedestals

15"W

27"H

## Bins

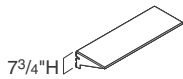


Understanding  
 ▶ Page 232  
 Specifying  
 ▶ Page 257

## Bins

	24"W	30"W	36"W	42"W	48"W	60"W	72"W
15 3/4"D	●	●	●	●	●	●	●

## Laminate Common Shelves



Understanding  
 ▶ Page 234  
 Specifying  
 ▶ Page 258

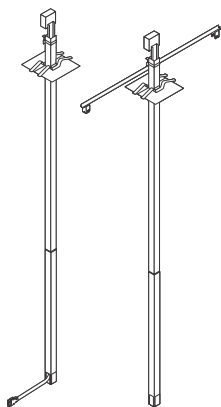
## Laminate Common Shelves

	24"W	30"W	36"W	42"W	48"W
15"D	●	●	●	●	●

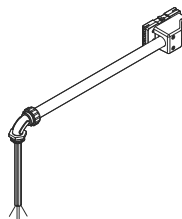
## Panel Wiring and Cabling



**Receptacles**  
 Understanding  
 ▶ Page 212  
 Specifying  
 ▶ Page 261



**2" x 2" Power and Cable Poles**  
 Understanding  
 ▶ Page 214  
 Specifying  
 ▶ Pages 262–263

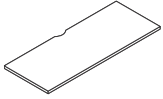


**Base Power-Ins**  
 Understanding  
 ▶ Page 216  
 Specifying  
 ▶ Page 264



**Grommet Package**  
 Understanding  
 ▶ Page 222  
 Specifying  
 ▶ Page 265

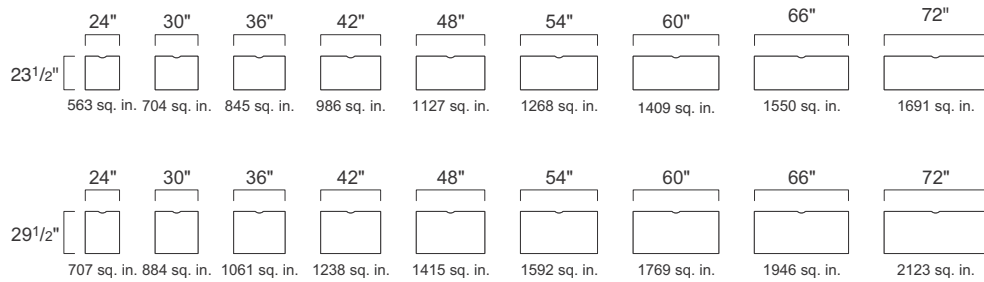
## Worksurfaces



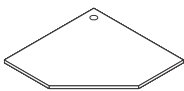
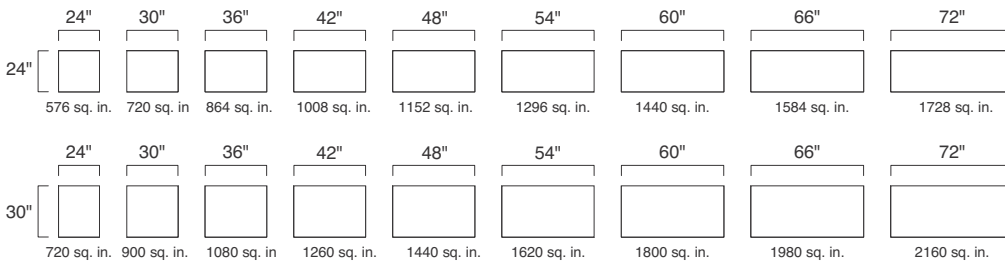
Understanding  
 ▶ Page 224  
 Specifying  
 ▶ Pages 266–267

## Straight Worksurfaces

### With 1/2" Cord Drop

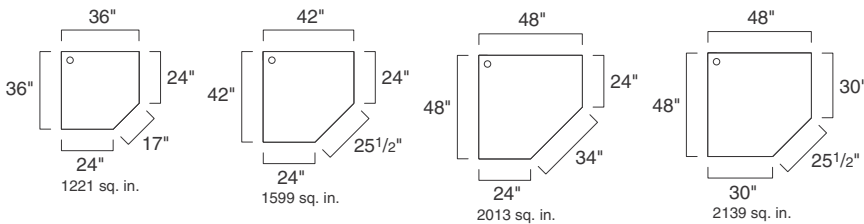


### With Full Depth

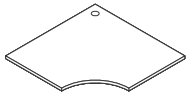


Understanding  
 ▶ Page 224  
 Specifying  
 ▶ Page 268

## Straight Corner Worksurfaces

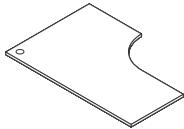
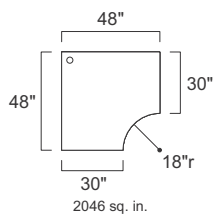
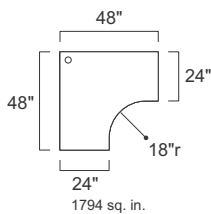
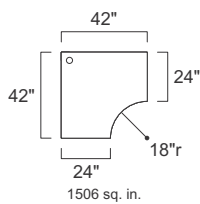
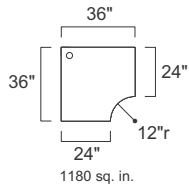


## Worksurfaces, continued



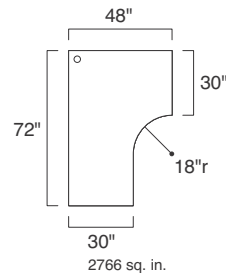
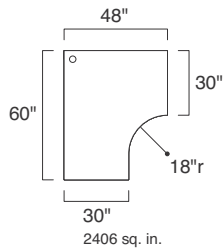
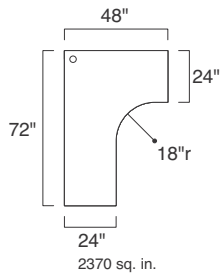
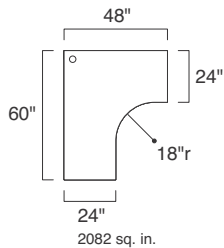
Understanding  
 ▶ Page 224  
 Specifying  
 ▶ Page 269

## Curved Corner Worksurfaces



Understanding  
 ▶ Page 224  
 Specifying  
 ▶ Pages 270–271

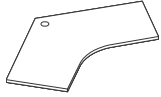
## Extended Curved Corner Worksurfaces\*



\* Left-hand is shown. Right-hand is also available.

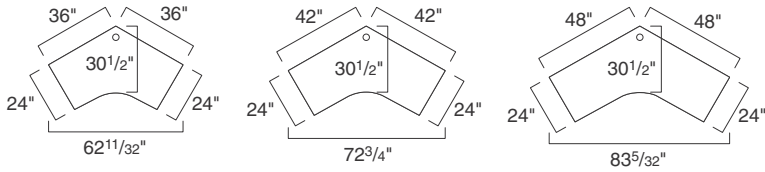
TEKTIS

## Worksurfaces, continued



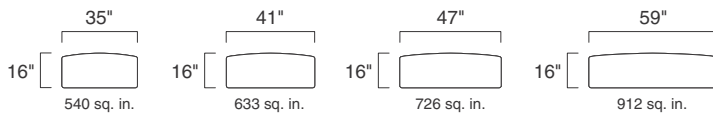
Understanding  
 ▶ Page 224  
 Specifying  
 ▶ Page 272

## 120° Corner Worksurfaces

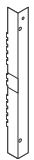


Understanding  
 ▶ Page 224  
 Specifying  
 ▶ Page 273

## Transaction Worksurfaces

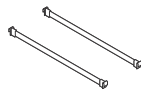


## Fixed Pedestals Accessories



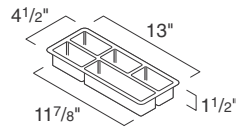
### Pedestal Filler

Understanding  
 ▶ Page 230  
 Specifying  
 ▶ Page 274



### Rails

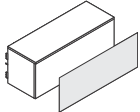
Understanding  
 ▶ Page 230  
 Specifying  
 ▶ Page 275



### Pencil Tray

Understanding  
 ▶ Page 230  
 Specifying  
 ▶ Page 275

## Flexible Markerboard Surface

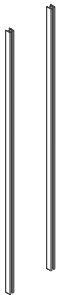


Specifying  
▶ Page 276

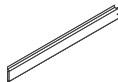
## Flexible Markerboard Surface

	30"W	36"W	42"W	48"W
16¼"H	●	●	●	●

## Wall Channels and Wall Channel Horizontal Braces



**Wall Channels**  
Understanding  
▶ Page 235  
Specifying  
▶ Page 259

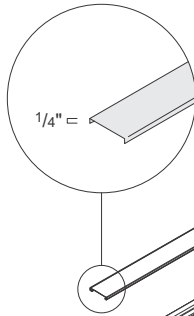
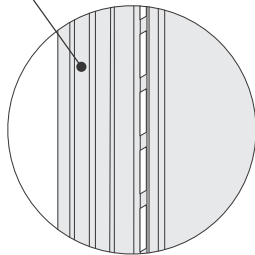


**Wall Channels  
Horizontal Braces**  
Understanding  
▶ Page 235  
Specifying  
▶ Page 260

# Monolithic Panels

**Panels** are constructed with a rigid, tubular steel frame and are shipped fully assembled. Remember to order trim separately.

**Vertical slots in panel** accommodate hang-on components, overhead storage bins, shelves, worksurface supports, and connector brackets. Components can be mounted at 1" increments.

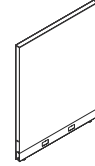


**Base cavity** accepts a factory-installed powerway  
▶ See *Powerways*, page 210.

**Leveling glides** adjust 1 1/2" to install panels on uneven floors.

**Removable base cover** has receptacle knockouts. Base covers have a receptacle opening on the left and right side of the base cover. *Exception: 24"W base covers have a receptacle opening in the center of the base trim.*

## Product Details



**Tackable acoustical** has a skin on each side, covered with horizontal surface fabric.

## Wiring & Cabling

**Panel frames** have hollow interior to allow routing cables from top cap through to base raceway.

**Chicago electrical code** requires that all electrical connections be hardwired in the field. Order a non-powered panel and have the electrician obtain conduit and receptacles (Leviton 5325) to make the connections in the field.

## Surface Materials

**Base cover, top cap, and border**

- Paint

**Panel surface**

- Fabric

*Tip: Fabric is applied horizontally on the screen. Fabric must be of the same fabric group and color on both sides.*

## Actual Dimensions

<b>Height</b>	42", 48", 54", or 66"
<b>Width</b>	24", 30", 36", 42", 48", or 60"
<b>Thickness</b>	2"
<b>Base Raceway Height</b>	3 5/8"
<b>Glides</b>	1 1/2" adjustment

# Monolithic Panels and Stacker Options

**TEKTIS** allows a wide variety of panel arrangements to meet specific functional and aesthetic needs.

### Stacking Guidelines

**Stackers** are available in 12"H, 18"H, or 24"H in tackable acoustical or glass.

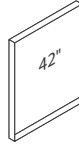
**Maximum height** is 78".

**Maximum number of tackable acoustical stackers** is three.

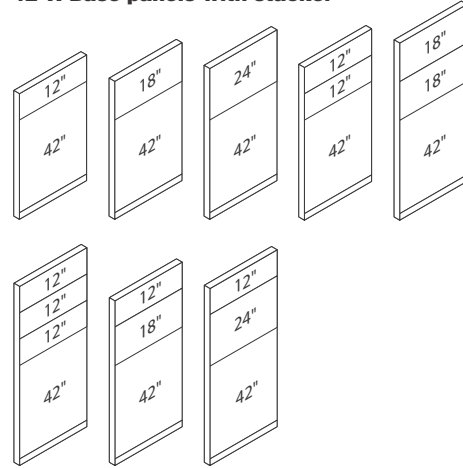
**Maximum number of glass stackers** is one.

**Any height base panel** can be used with stackers.

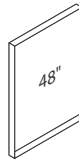
## 42"H Base panels



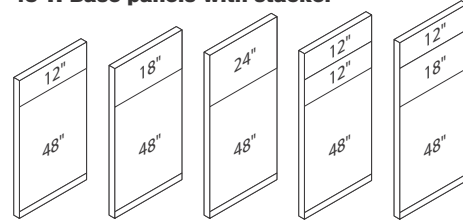
## 42"H Base panels with stacker



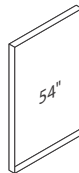
## 48"H Base panels



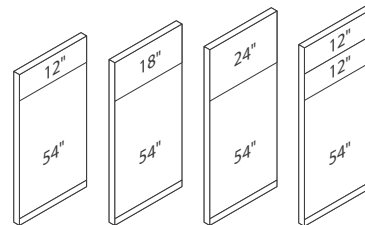
## 48"H Base panels with stacker



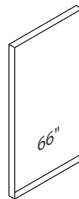
## 54"H Base panels



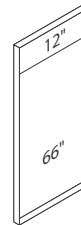
## 54"H Base panels with stacker



## 66"H Base panels



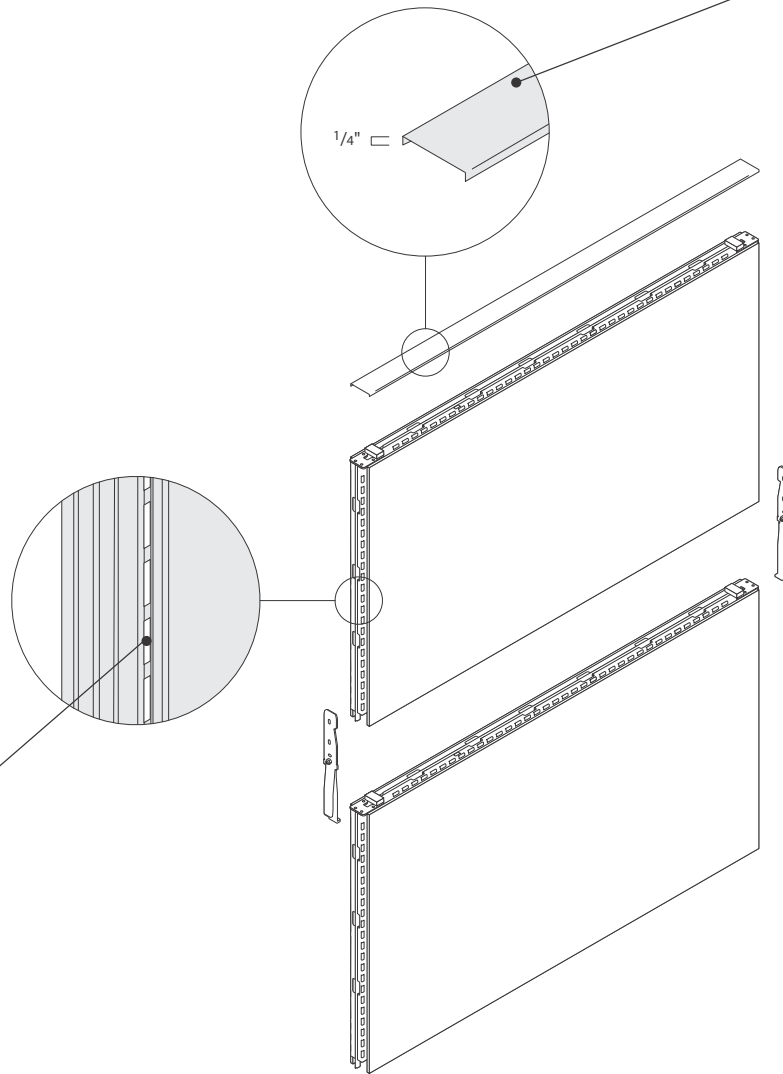
## 66"H Base panels with stacker



# Panel Stackers

**Stackers** are constructed with a rigid, tubular steel frame and are shipped fully assembled.

**Top cap and top cap aligner** from base panel are used to trim the top of stacker.



**Vertical slots in stackers**, identical to slots in base panel, accommodate overhead storage, laminate common shelves, and connector brackets.

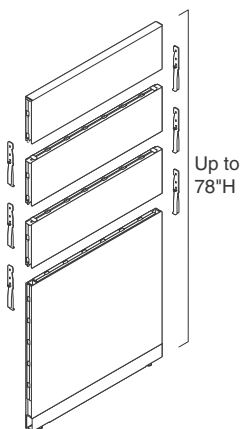
## Actual Dimensions

<b>Height</b>	12", 18", or 24"
<b>Width</b>	24", 30", 36", 42", 48", 60", or 72"
<b>Thickness</b>	2"

## Product Details

**All existing base panels** accept stackers.

**Stackers** do not include vertical trim, must be specified separately.



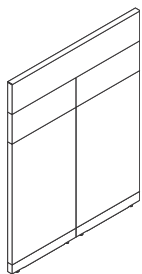
Up to  
78"H

**Base panels** can accept one, two, or three stackers, up to a total height of 78". Base panels can only accept one glass stacker. All stackers are load bearing, but load cannot be mounted above 66" height.

▶ See page 191.

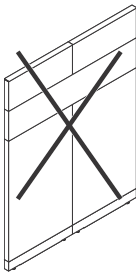
**Two fork connectors** are included with every stacker.

**Attaching stackers to panels** will not cause disruption to existing panel connections.



**Spanning stackers** are available in 48", 60", or 72" widths.

**Stacker** can span over an in-line connection between two base panels or two stackers. Width of stacker must equal total width of two base panels.



**Two smaller stackers** cannot be attached to the top of a larger stacker or panel.

**Stackers** are available in two surface options.



**Tackable acoustical**—skin on each side, covered with horizontal surface fabric.



**Glass**—single pane of clear, tempered safety glass on panel centerline, surrounded by painted border.

*Tip: Fabric and glass stackers cannot be combined on the same panel.*

## Application Topics

**Maximum height with base panel and stackers** cannot exceed 78".

**Maximum number of stackers** is three.

**Any base panel** can accept stackers.

**Bins and shelves** can hang from first or second, stacker, not above 66" in height.

**When** adding a stacker to existing panels with a power or cable pole connected at L-, T-, or X- corner, the universal panel connector can not be used. Contact [orders@amqsolutions.com](mailto:orders@amqsolutions.com) to order service parts for special connections.

**Panel stackers** cannot be used in a V- or Y-configuration.

## Surface Materials

**Border**

- Paint

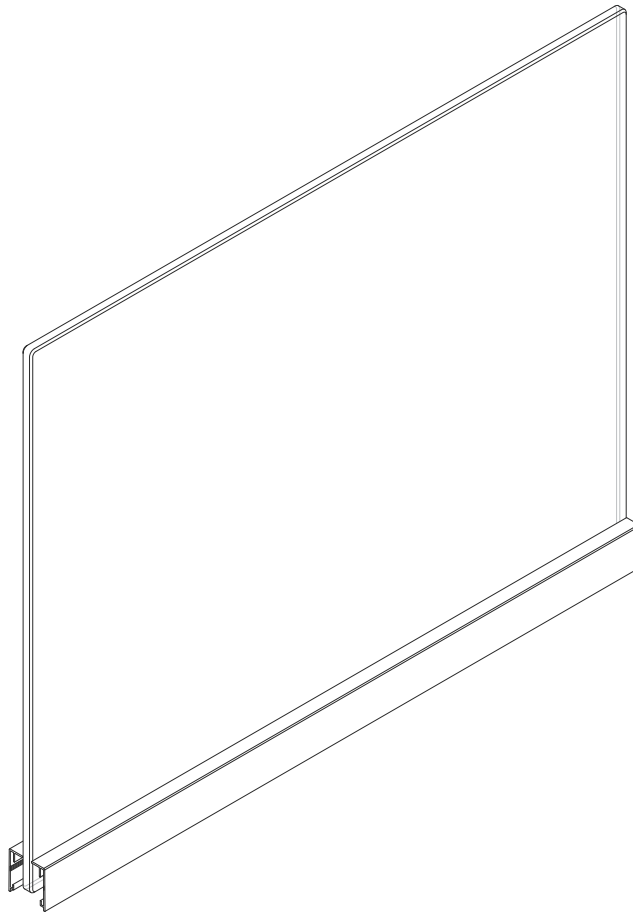
**Panel surface**

- Fabric
- 6500 Clear Glass

*Tip: Fabric is applied horizontally on the screen. Fabric must be of the same fabric group and color on both sides.*

# Frameless Glass Stackers

**Frameless glass stackers** mount to the top of panels to enhance privacy and daylight while balancing focus and openness to promote collaboration between workstations.



## Actual Dimensions

<b>Height</b>	6", 12", and 18"
<b>Width</b>	24", 30", 36", 42", 48", and 60"
<b>Glass Thickness</b>	3/8"

## Product Details

**Frameless glass stacker** is secured to the panel with two bracket supports below the top cap. Two brackets are used below the stacker top cap to attach the glass to the panel.

**Frameless glass stackers** include glass screen, brackets, and top caps.

## Application Topics

**Frameless glass stackers** can be placed on the top of a base panel only.

**Frameless glass stackers** cannot be stacked on top of any tackable or framed glass stackers.

**A single frameless glass stacker** cannot span two or more in-line panels.

**At an in-line change-of-height condition**, a stacker top cap should be specified when a frameless glass stacker is positioned on the taller in-line panel.

## Surface Materials

### Glass

- 6500 Clear Glass
  - 6530 Frosted Glass
- Tip: Frosted glass for Tektis frameless glass is a laminated construction. There may be variation in color, texture, and finish between the sample of 6530 Frosted Glass and the actual product.*

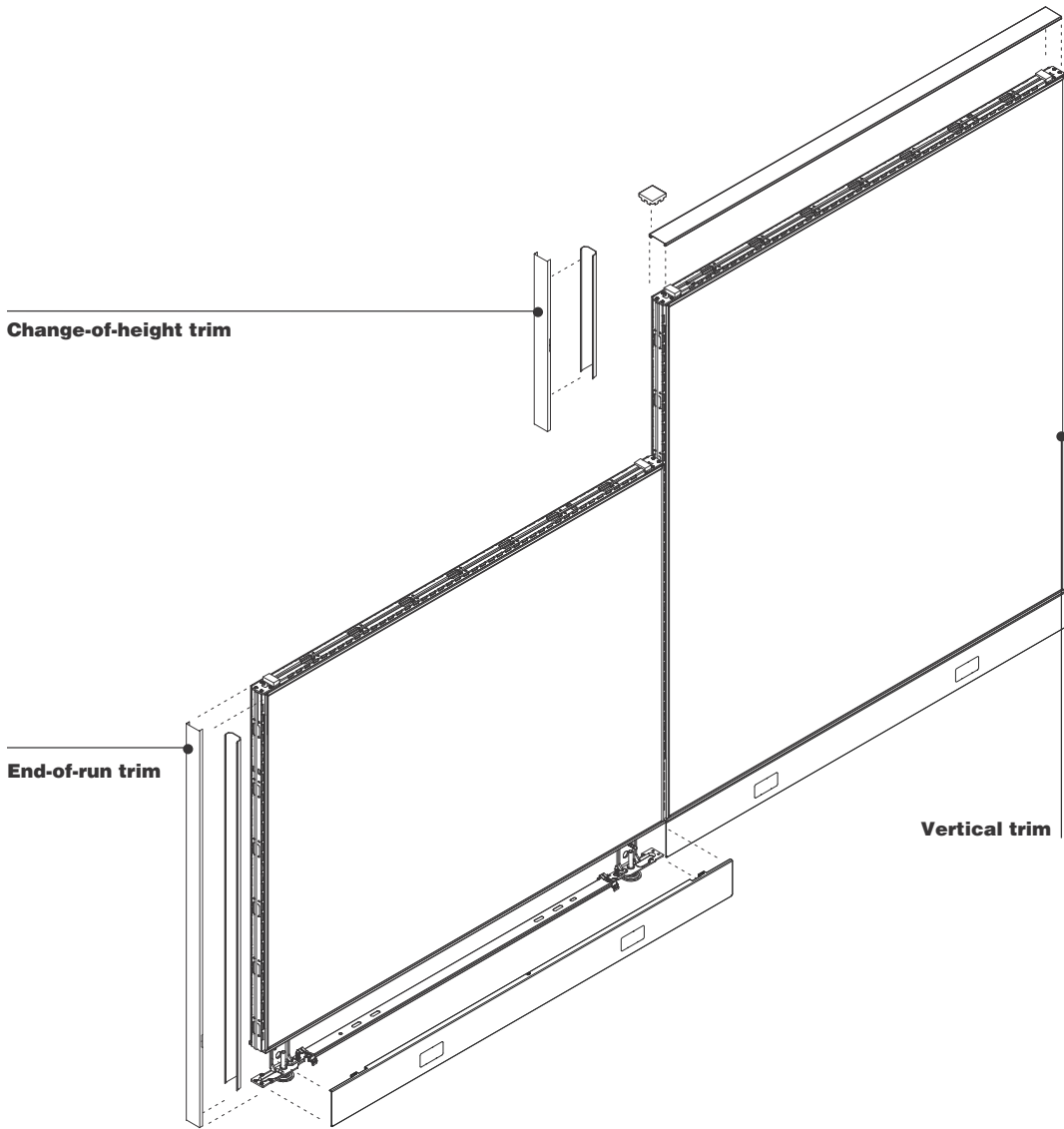
### Top cap

- Paint



# Panel Trim

**Steel top caps** are standard in low height.

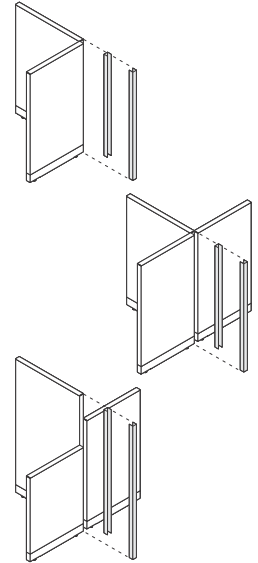


**Change-of-height trim**

**End-of-run trim**

**Vertical trim**

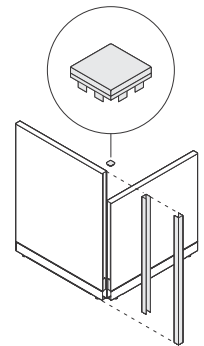
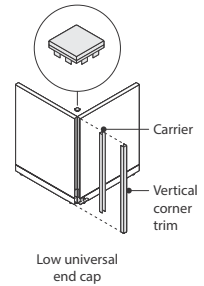
## Product Details



**Vertical corner trim** allows cables to be laid in before the cover is snapped into place and can be removed for cable access. Corner trim is required for L-, T-, and X-configurations.

**Always specify vertical corner trim** the same height as the tallest panel.

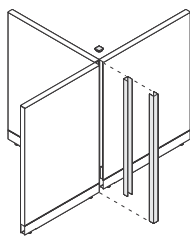
### L-configurations:



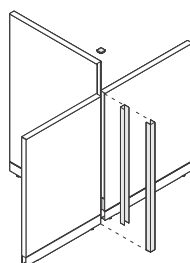
## Actual Dimensions

	<b>Vertical Corner Trim</b>	<b>End-of-Run Trim</b>	<b>Change-of-Height Trim</b>
Height	42", 48", 54", or 66"	42", 48", 54", 60", 66", 72", or 78"	6", 12", 18", 24", or 36"
Standard Thickness	1/4"	1/4"	1/4"

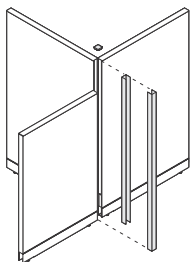
**T-configurations:**



Low universal end cap

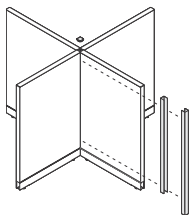


Low universal end cap



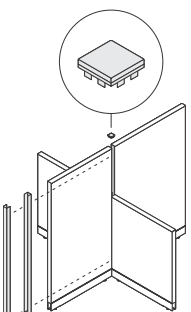
Low universal end cap

**X-configurations:**

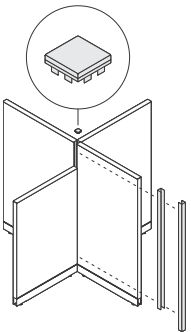


Low universal end cap

*Tip: In an X-configuration, carrier and vertical corner trim must be attached to one panel prior to installation of last panel.*



Low universal end cap

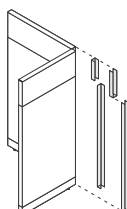
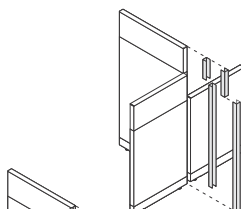
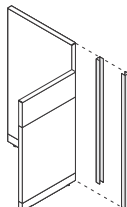


Low universal end cap

**End caps:**



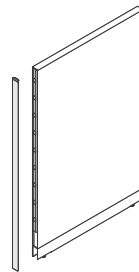
Low universal end cap



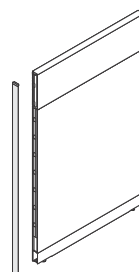
**Vertical corner trim and corner change-of-height trim** are required in combination for L-, T-, and X-configurations when stackers are used. All corner trims include a low trim end cap.

**Always specify vertical corner trim** the same height as the tallest base panel. Specify vertical corner change-of-height trim to cover the ends of stackers.

**Vertical end-of-run trim** covers the exposed end of panels and includes a low trim end cap.



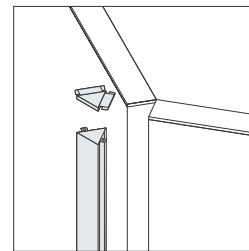
**Vertical end-of-run trim** must match height of base panel.



**Vertical end-of-run trim** must match combined height of base panel and stacker.



**Vertical in-line change-of-height trim** is available 6"H, 12"H, 18"H, 24"H, and 36"H. Trim covers the exposed section of the taller panel when panels of different heights are joined.



**120° vertical corner trim** is required for all 120° connections. The same 120° vertical corner trim is used for two- and three-way connections. Both two- and three-way end caps are included with each 120° vertical corner trim package.

▶ Page 252

**Application Topics**

**Always** specify vertical corner trim the same height as tallest panel.

**When specifying a base panel and a stacker,** specify corner trim to match base panel and change-of-height trim piece to cover the ends of stacker.

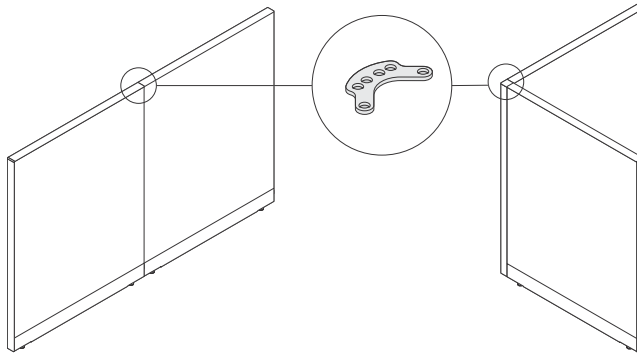
**When base panel and stacker** are specified in end-of-run trim must match total overall height.

**Surface Materials**

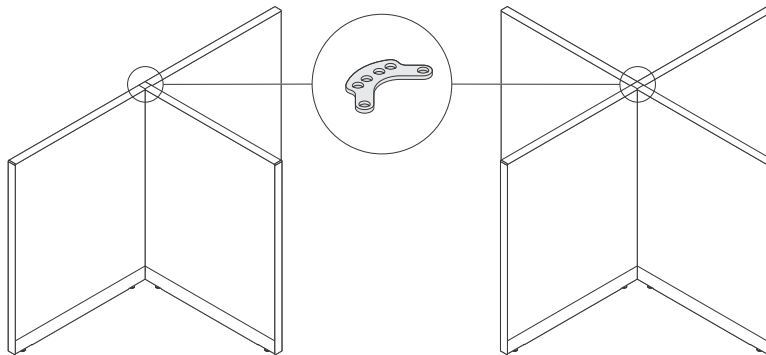
- Paint

# Panel Connectors



**Universal connector package** joins panels of the same height in a straight line or in L-, T-, or X-configurations. The package, included with panels, contains two universal connectors—one for the top and one for the bottom connection.





**Same connector** is used at both the top and bottom of panel.



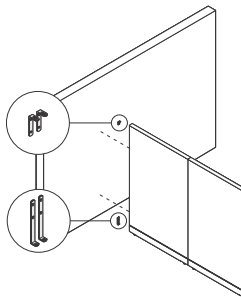
**Different slots** are used to create in-line, L-, T-, or X-conditions.

 Left Hand  
 Right Hand  
 Change-of-Height Connector



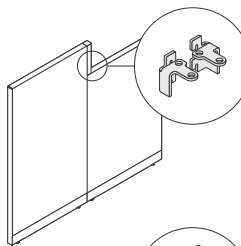
  
  
 Wall Start

**Product Details**



**Wall start connector package** is used to anchor a panel run to a perpendicular wall. Mounting screws that connect the brackets to the panel are included in each package.

*Tip: Vertical end-of-run trim is not required at the end of panel that is attached to the wall.*



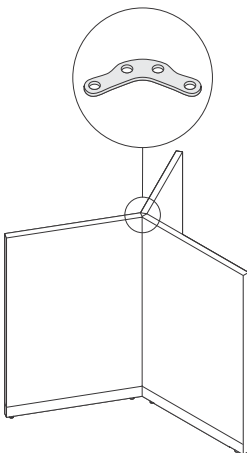
**Change-of-height in-line and corner panel connector package**

is used to join panels at varying heights in a straight line or at 90° angles. Package contains left and right connectors for both in-line and corner configurations.

*Tip: Change-of-height in-line and corner panel connectors cannot be used in 120° configurations.*

**Left and right in-line connectors** are required to connect panels in a straight line.

**One-handed corner connector** is required for connecting panels at 90°.



**To connect panels in a 120° application**, a 120° panel connector is required. A two-panel connection requires one 120° connector package. A three-panel connection requires three 120° connector packages.

*Tip: Change-of-height in-line and corner panel connectors cannot be used in 120° configurations.*

▶ Page 252

**120° connectors** are for the same height panels only.

**120° and 90° connections** can occur within the same workstation.

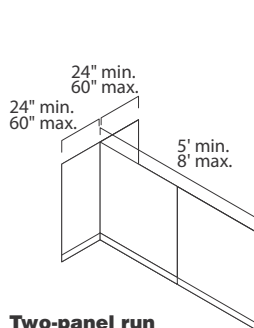
**Surface Materials**

**Universal and 120° connector**

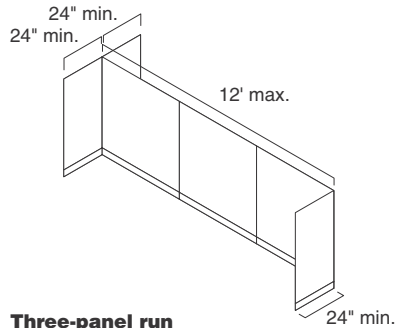
- 0835 Black

# Stability Guidelines

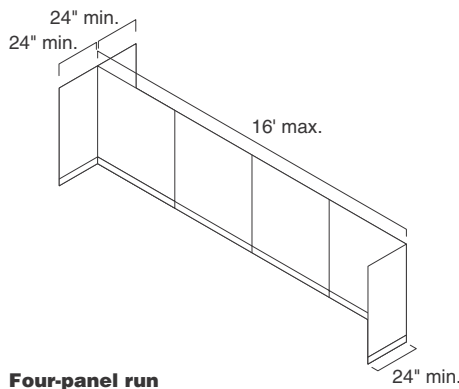
## Tackable Acoustical Panels without Components



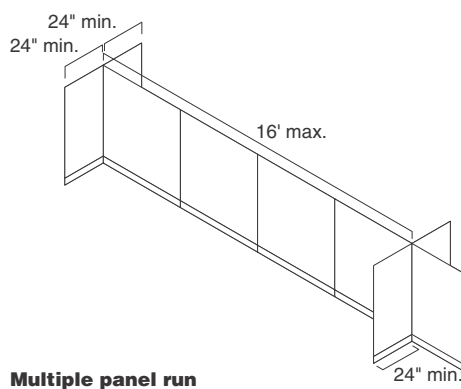
**Two-panel run**



**Three-panel run**



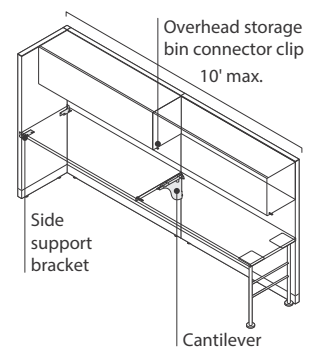
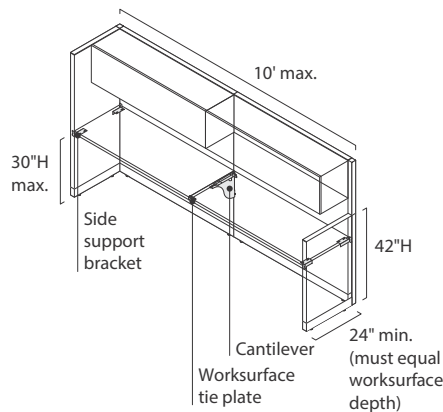
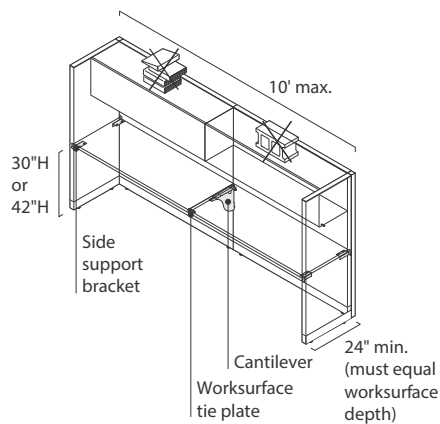
**Four-panel run**



**Multiple panel run**

## Tackable Acoustical Panels

### Two-Panel Run with Supported Components



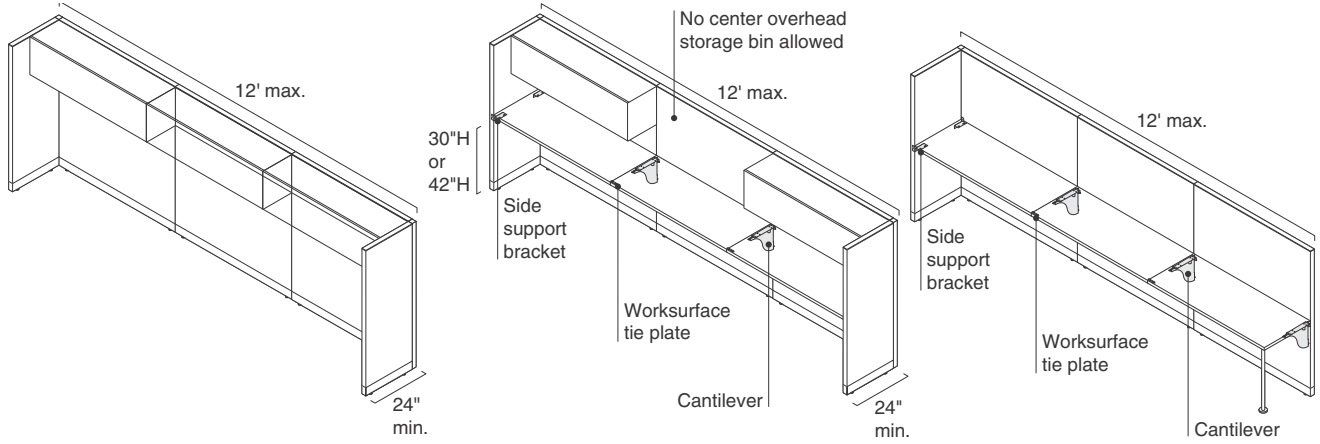
#### Optional worksurface supports:

- 20"W H-leg
- Pedestal with filler
- Lateral file
- End panel

*Tip: Overhead storage bins cannot support any load on top.*

**Tackable Acoustical Panels, continued**

**Three-Panel Run with Supported Components**



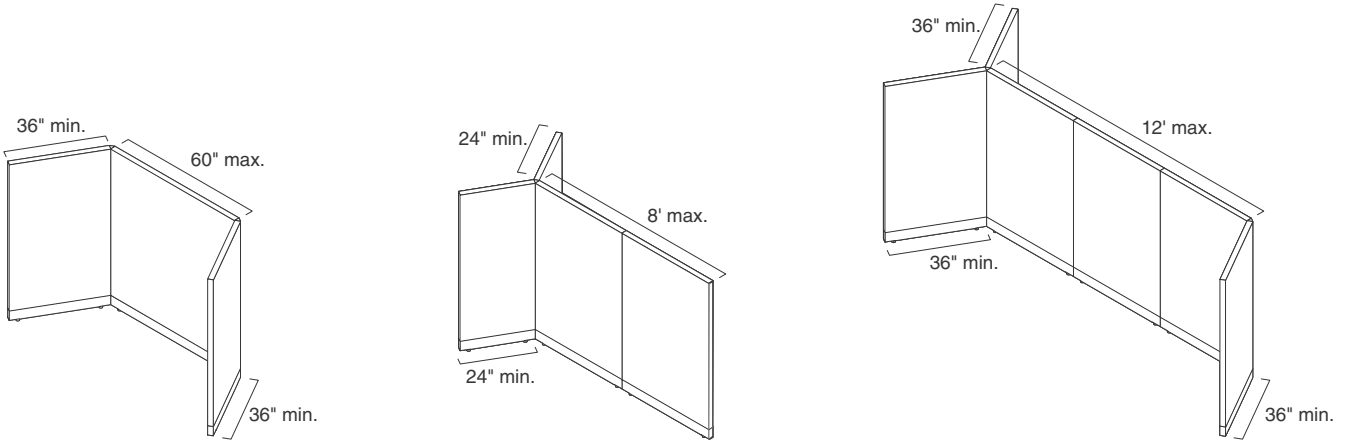
**Optional worksurface supports at 30"H:**

- 20"W H-leg
- Pedestal with filler
- End panel

*Tip: Overhead storage bins cannot support any load on top.*

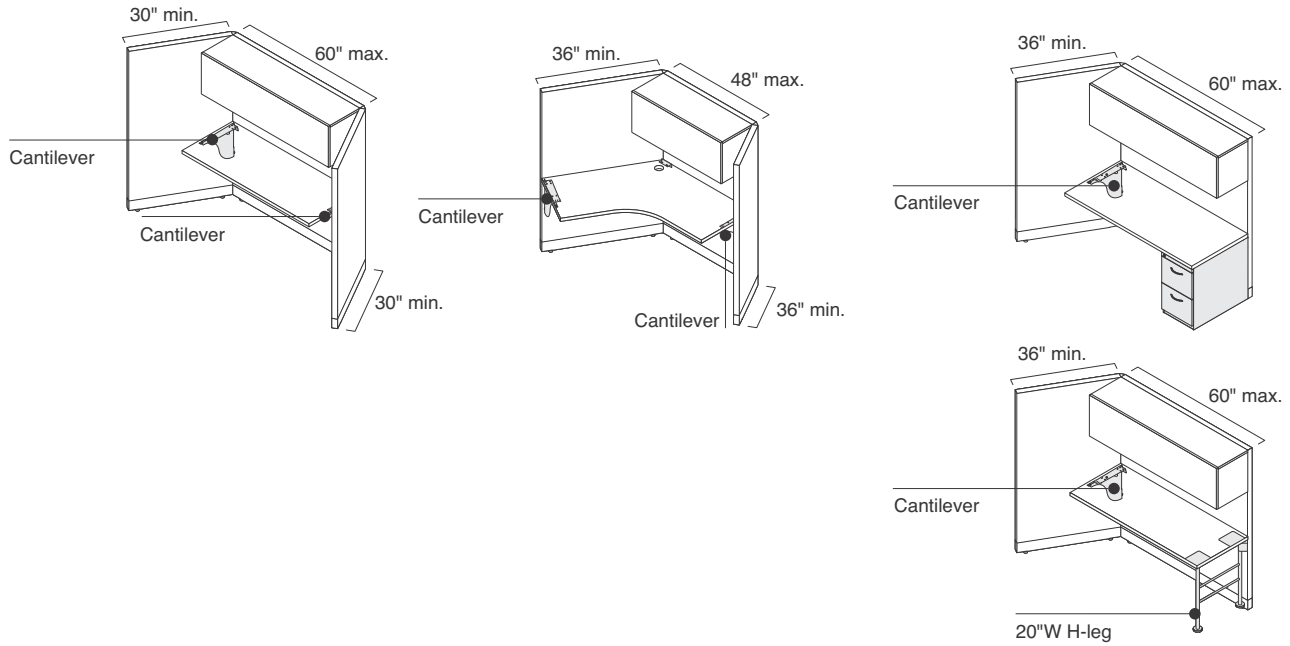
**Tackable Acoustical Panels without Components**

**120° Connection**



**Tackable Acoustical Panels with Supported Components**

**One Panel—120° Connection**



**Optional worksurface supports:**

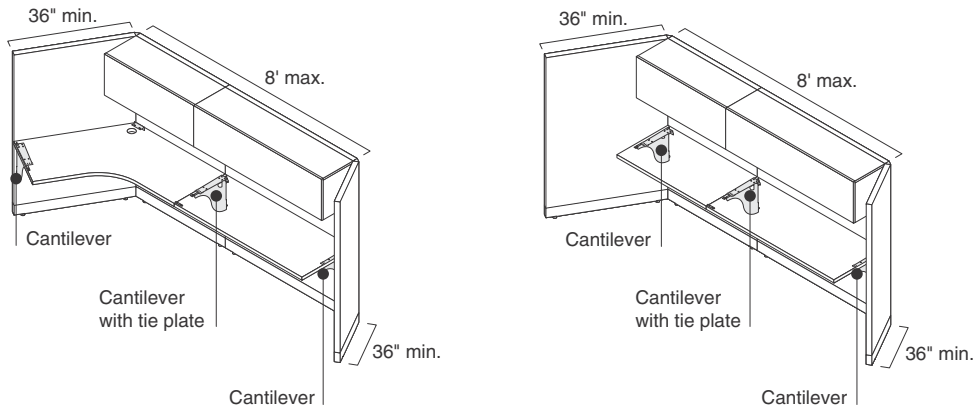
- Pedestal with filler
- 90° panel connection—panel width must match worksurface depth
- End panel

**Optional worksurface supports:**

- 90° panel connection—panel width must match worksurface depth
- 20" W H-leg

**Tackable Acoustical Panels with Supported Components, continued**

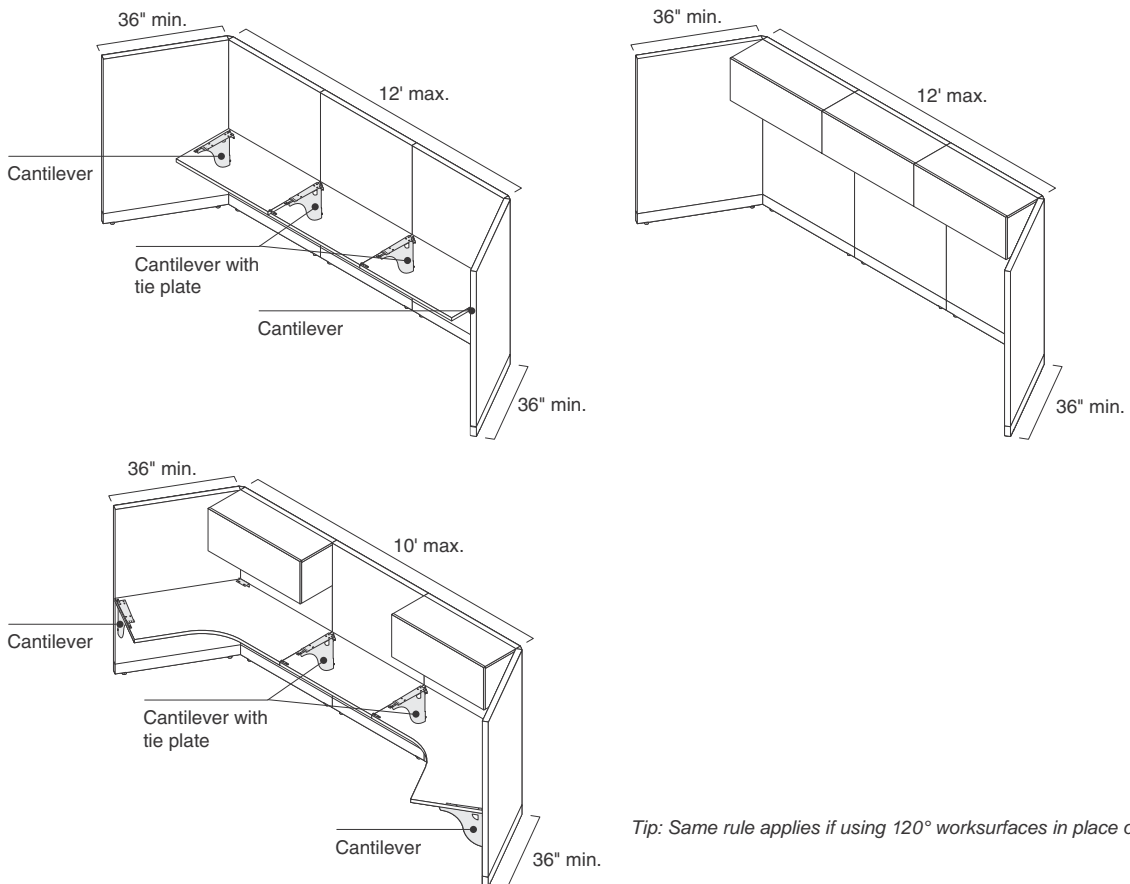
**Two-Panel Run—120° Connection**



**Optional worksurface supports:**

- Pedestal with filler
- 90° panel connection—panel width must match worksurface depth
- 20"W H-leg

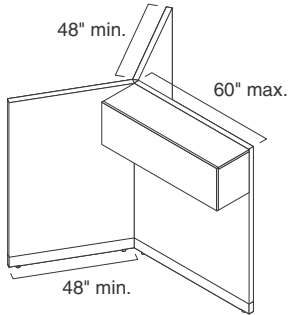
**Three-Panel Run—120° Connection**



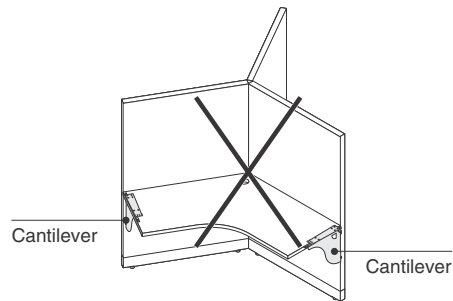
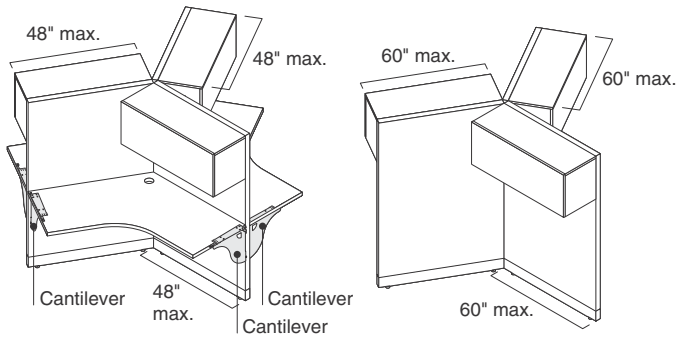
*Tip: Same rule applies if using 120° worksurfaces in place of straight worksurfaces.*

**Tackable Acoustical Panels—Three-Way 120° Connection**

**Three Panel 120° Connection with One Supported Component**



**Three Panel 120° Connection with 120° Worksurface and up to One Additional Component**



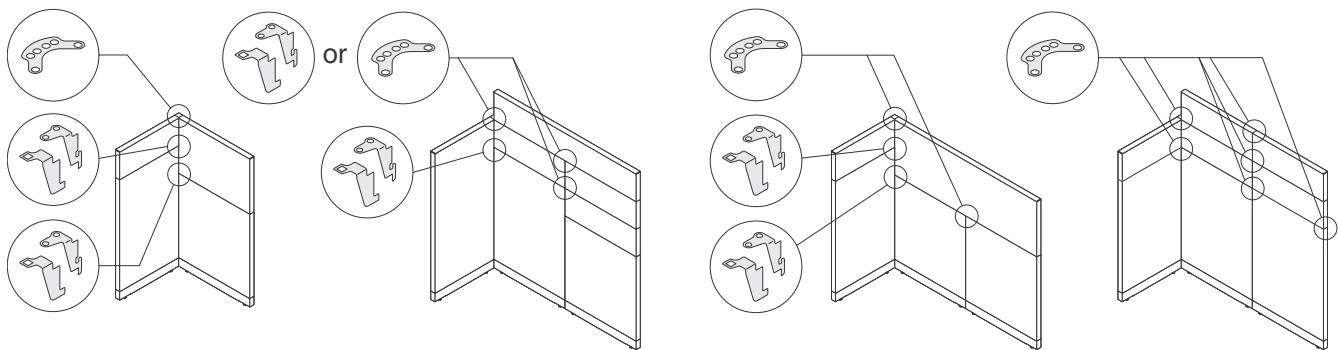
*Tip: Loads must be counterbalanced in this application.*

*Tip: Worksurface needs to be supported to floor or application needs to be counterbalanced.*

**Panels and Panel Stackers**

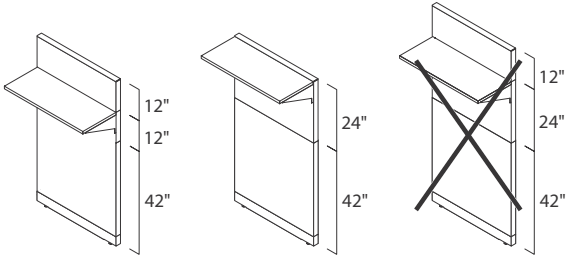
**Base panels** can accept one, two, or three stackers, up to a total height of 78". Base panels can accept only one glass stacker. See below for additional rules and exceptions.

**Universal or change-of-height connectors** must be used at top of base panel and each stacker wherever possible to increase stability.



**Panels and Panel Stackers, continued**

All stackers are load bearing, but load cannot be mounted above 66" height.



# Circuit Specifications

Detailed Information for the Electrical Engineer

## Five wiring schematics

are available for TEKTIS—two 3-circuit systems and three 4-circuit systems.

## All the components in an electrical distribution network

must use the same wiring schematic. The components (power poles, base power-ins, and receptacles) snap together and are keyed to make it impossible to connect mismatched parts. Color-coded and labeled components make it easy for installers to identify which wiring schematic each component is dedicated to.

## Color coding

For power components manufactured before June 19, 2023:

- 3 circuits shared = Black
- 3 circuits separate = White
- 4 circuits 3+D = Black
- 4 circuit 3I+1 = Tan
- 4 circuit 2+2 = Grey

For power components manufactured on or after June 19, 2023:

- 3 circuits shared = Blue
- 3 circuits separate = Rust
- 4 circuits 3+D = Black
- 4 circuit 3I+1 = Black
- 4 circuit 2+2 = Brown

## Overview

### Three-circuit electrical components with shared neutrals

are standard with 5 wires to provide three circuits that share one oversized neutral and one ground.

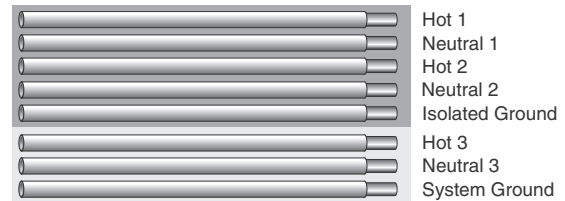
### 3 Circuit Shared Neutral, 5 Wires



### Three-circuit with separate neutrals

have 8 wires providing three circuits, each with its own separate neutral. The first two circuits share an isolated ground; the third uses the system ground.

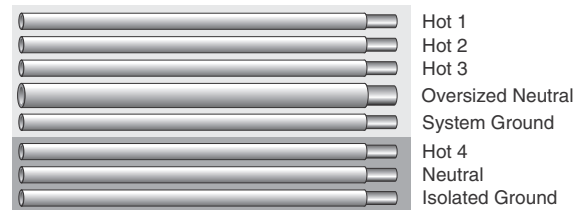
### 3 Circuit Separate Neutral, 8 Wires



### Four-circuit 3+D

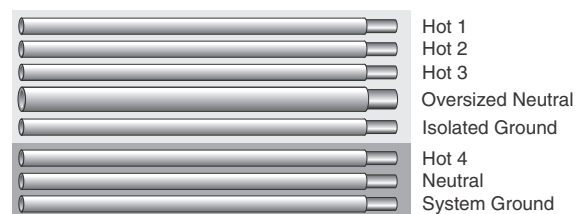
are standard with 8 wires to provide four circuits. Three of these circuits share an oversized neutral and a system ground while the remaining circuit has its own neutral and isolated ground.

### 4 Circuit 3+D, 8 Wires



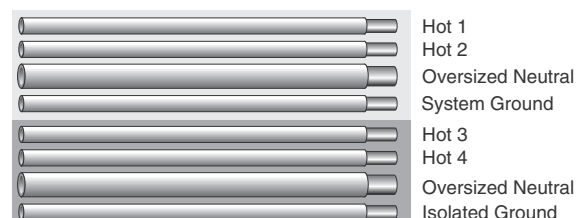
**Four-circuit, 3I+1** again have 8 wires but with three circuits that share an oversized neutral and isolated ground. The fourth circuit has its own neutral and is attached to the system ground. This electrical system is like the standard 3+D, but the grounds are switched, providing three isolated circuits and one general purpose circuit as compared to one isolated circuit and three general purpose circuits.

### 4 Circuit 3I+1, 8 Wires



**Four-circuit 2+2** also have 8 wires but provide two circuits that share an oversized neutral and a system ground and an additional two circuits with a second oversized neutral and an isolated ground.

### 4 Circuit 2+2, 8 Wires



# How to Calculate Power Needs

Use This to Determine How Many Power-Ins You'll Need

**When planning a power network,** you must calculate the amperage requirements of all your electrical components so you can provide sufficient electricity to power them.

**If your usage is not known in advance:** The National Electrical Code (NEC) allows a maximum of 13 receptacles on each 20-amp circuit. This provides up to 30 receptacles for each 3-circuit power-in.

**If your usage is known in advance:** Add up the amperage used by each piece of equipment in the workstation. Whenever you reach 60 amps (20 amps times 3 circuits) from items that are likely to be used at the same time, you have reached the limit for a single power-in. Specify another power-in and continue until all equipment is powered.

If the circuits will normally be subject to a continuous load (three or more hours of continuous use, such as lights or computers), the NEC requires that circuit capacity be "de-rated" by 20 percent. Therefore, treat circuits used for continuous loads as if they were rated at 16 amps instead of the regular 20 amps.

Try to anticipate future increases in power requirements and build some excess capacity into your plan.

▶ See table at right for typical and actual amperage usages for components.

To calculate amperage when the wattage of a device is known, divide watts by 120.

Some appliances, such as large copiers, coffee makers, or space heaters require most of the current available on a 20-amp circuit. It is recommended that such devices be supplied with their own receptacle/circuit, directly from the building. This leaves the capacity of the furniture circuits available for the more dynamic requirements of the office equipment.

Local electrical codes vary. Consult a qualified electrical contractor or engineer for the proper planning of electrical circuits in your locale.

## Approximate power consumption for common devices

Device	Wattage	Amperage	Voltage	Number of Devices Supported on Single 20 Amp Circuit*
Laptop	90	0.8	110	20
CPU/Desktop Computer	120	1.1	110	15
Monitor	60	0.5	110	29
Phone	5	0.0	110	352
High Power Tablet (e.g. Surface Pro)	40	0.4	110	44
Low Power Tablet (e.g. iPad Air)	15	0.1	110	117
Desktop Printer	40	0.4	110	44
42" LCD Screen	210	1.9	110	8
DVD Player	25	0.2	110	70
Projector	175	1.6	110	10
Desktop Lamp	19	0.2	110	93
Large Printer/Copier (high)	1900	17.3	110	1
Large Printer/Copier (low)	850	7.7	110	2
Paper Shredder	360	3.3	110	5
Desktop Fan	20	0.2	110	88
Standing Fan	180	1.6	110	10
Coffee Maker (high)	1200	10.9	110	1
Coffee Maker (low)	600	5.5	110	3
Microwave (high)	400	13.6	110	1
Microwave (low)	150	5.5	110	3
Refrigerator (high)	1500	3.6	110	4
Refrigerator (low)	200	1.4	110	12
Vacuum (high)	1500	13.6	110	1
Vacuum (low)	200	1.8	110	9
Space Heater (high)	1500	13.6	110	1
Space Heater (low)	750	6.8	110	2

*Tip: These calculations are estimations and are meant solely for informational purposes. It is important to conduct proper power planning for each installation to prevent overloading a circuit.*

# Special Requirements for Chicago

	Chicago Code	Specification:	Electrician will supply:
<p><b>Panel Requirements</b></p> <p><b>Chicago code</b> requires hardwiring of all electrical components.</p>	<p><b>Panel</b> must be hardwired in the field.</p> <p><b>Electrician hardwires</b> all receptacle boxes and conduits into panel bases in the field.</p> <p><i>Tip: Panel depth prohibits use of standard device boxes for back-to-back receptacles in Chicago.</i></p>	<ul style="list-style-type: none"> <li>• <b>Order panels</b> with factory-installed power base covers with receptacle knockouts where you intend to install receptacles. <i>Tip: Chicago code doesn't require a special base cover with different receptacle locations.</i></li> <li>• <b>Receptacles</b> in Chicago are supplied by electrician. Contact <a href="mailto:orders@amqsolutions.com">orders@amqsolutions.com</a> to order service parts for special connections. <i>Tip: Because receptacles in Chicago cannot be installed back-to-back, you may want to avoid powered panels that are 30"W or less. These panels only have one receptacle location on each side, so these panels can only accommodate one duplex-size receptacle.</i></li> <li>• <b>Order corner fillers</b> for L-, T-, and X-configurations separately to conceal electrical conduits.</li> </ul>	<ul style="list-style-type: none"> <li>• Connection to building power supply</li> <li>• Wires</li> <li>• Fittings</li> <li>• Duplex receptacle (Leviton 5325-Decora style)</li> <li>• Electrical components</li> </ul>

### Test and verify capacities for your individual situation.

We recommend that testing be conducted using your specific cable, as well as the furniture configuration you are considering. Cable capacities in this table are based on actual cable studies performed by an independent contractor following EIA/TIA codes and practices and can be taken as an accurate assessment of maximum practical capacity. Actual cable capacities may vary slightly depending on which manufacturer produced the cable and the specific field conditions.

**Cable capacities** are based on Category 6 and Category 6a cables at 55% fill capacity.

*Tip: Low top cap does not accept any cables.*

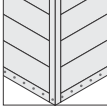
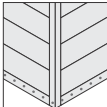
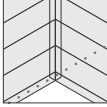
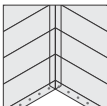
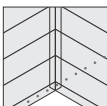
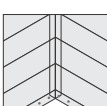
### Cables Tested

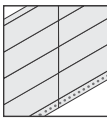
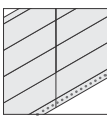
**A CommScope Systimax Gigaspeed 1071E Series Category 6 Cable**  
OD=0.23"

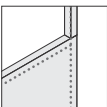
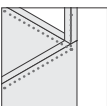
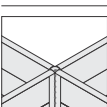
**B CommScope Systimax X10D 1091B Series Category 6A Cable**  
OD=0.285"

**Powerways reduce cable capacity.** An average of 10-15 cables will be reduced per powerway used. However, this number varies according to installation practices and the type of cables used.

**When laying cables vertically behind skins,** capacity is dependent on skin width.

	A	B
<b>L, T, X, V, and Y Horizontal Routing</b>		
 Lay-in cable routing (corner) at base of panel <b>with</b> power in L, T, or V configuration	9	5
 Lay-in cable routing (corner) at base of panel <b>without</b> power in L, T, or V configuration	32	21
 Lay-in cable routing (straight) at base of panel <b>with</b> power in X or Y configuration	9	5
 Lay-in cable routing (corner) at base of panel <b>with</b> power in X or Y configuration	9	5
 Lay-in cable routing (straight) at base of panel <b>without</b> power, or with powerway routed above in X or Y configuration	32	21
 Lay-in cable routing (corner) at base of panel <b>without</b> power, or with powerway routed above in X or Y configuration	32	21

	A	B
<b>Straight Horizontal Routing</b>		
 Lay-in cable routing at base of panel <b>with</b> power	8	5
 Lay-in cable routing at base of panel <b>without</b> power or with powerway routed above	32	21

	A	B
<b>Straight Vertical Routing</b>		
 Vertical cable routing inside power pole (used on an end, L or T configuration an end)	28 Hi	18 Hi
 Vertical cable routing inside power pole	28 Hi	18 Hi
 Through center of X	24	16

*Tip: Low top cap does not accept any cables.*

# Powerways

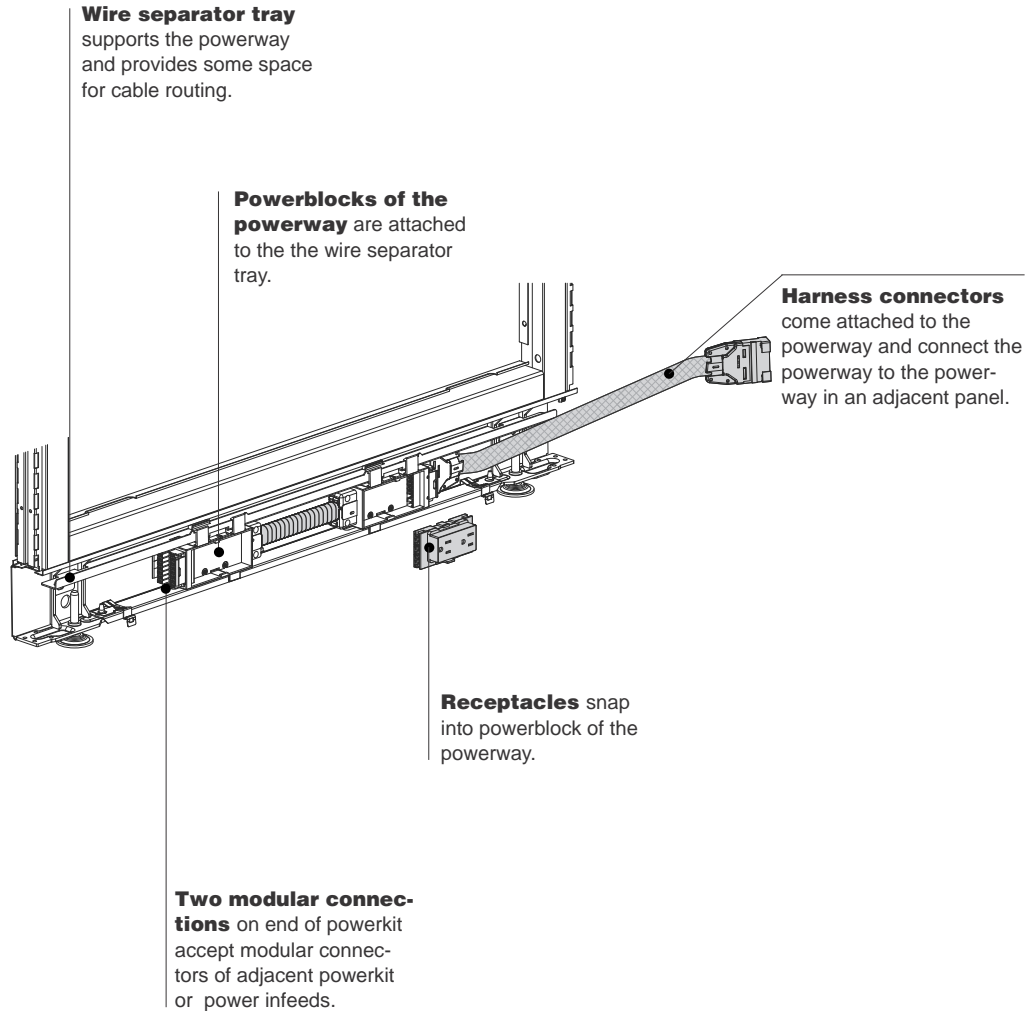
**Powerways** that are installed in the panel base cavity allow power to be distributed wherever panels go. They are concealed when properly installed.

**On June 19, 2023,** TEKTIS power components changed design. Power components manufactured before June 19, 2023 are not compatible with power components manufactured after June 19, 2023.  
▶ See *Power Components Transition Details* on page 218.

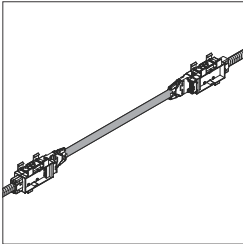
**All the components in an electrical distribution network** must use the same wiring schematic. Components are color coded and keyed to make it impossible to connect mismatched parts.

**Electrical systems** are designed in compliance with the National Electrical Code (NEC) and Canadian Electrical Code (CEC) to function as a multi-wire branch circuit. Installations should be made in accordance with the NEC or CEC provisions for multi-wire branch circuits.

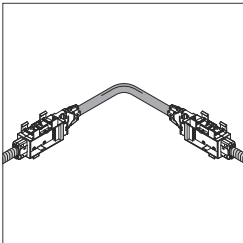
**Local electrical codes** vary. Consult a qualified electrical contractor or engineer for the proper installation of electrical equipment. Chicago, New York City, and Los Angeles have special requirements.



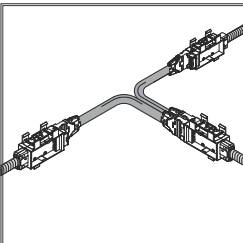
**Product Details**



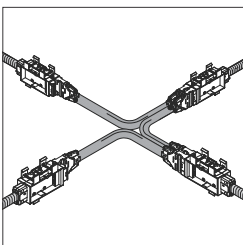
**Straight connection** is formed when a harness connector from one powerway attaches to the powerblock of the adjacent powerway.



**L-connection** is formed when a powerway connector harness turns to the left or right and connects to the powerblock of the adjacent panel.



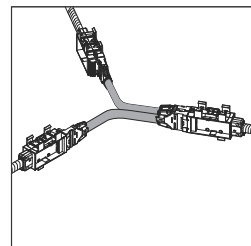
**T-connection** is formed by two powerway connector harnesses each turning in the same direction.



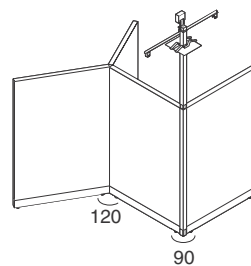
**X-connection** is formed by three powerway connector harnesses, each turning in the same direction.

The **powerway connector harness** comes attached to each powerway and can be removed in the field.

**Removing the powerway connector harness and adding it to the opposite end of the powerway powerblock** can be used to correct planning and installation oversights.



**Power** can be routed through the base of panels in a two- and three-panel, 120° connection.



(inside measurement)  
**2" x 2" power and cable poles** can bring building power and data from the ceiling to a 120° panel application at the end of a run or 90° connection only.

**Application Topics**

**Factory included powerway** for field installation replaces need to order separate powerways.

**Wiring and Cabling**

**Chicago, New York City, and Los Angeles** have special requirements.

**Chicago electrical code** requires that all electrical connections be hardwired in the field. Order a non-powered panel and have the electrician obtain conduit and receptacles (Leviton 5325) to make the connections in the field.

**Underwriters Laboratory (UL)** listed. These products have been designed to meet U.S. and Canadian national electrical and energy codes and most local building codes. Local electrical codes vary, so consult with your local authority having jurisdiction as they have final say if the products as installed are compliant with local code. Consult with a qualified electrician or electrical engineer for proper installation of all electrical equipment.

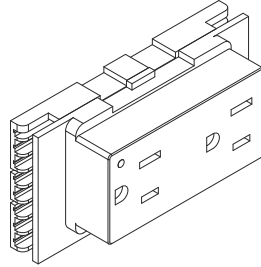
# Receptacle

**Receptacles** are ordered separately and installed in the field in the base cover knockout opening. Receptacles snap into the powerblock in the field. Receptacles are designed to link to a specific circuit.

**On June 19, 2023,** TEKTIS power components changed design. Power components manufactured before June 19, 2023 are not compatible with power components manufactured after June 19, 2023.

► See *Power Components Transition Details* on page 218.

**All receptacles** are duplex (two outlets) and are available in 15-amp.



## Product Details

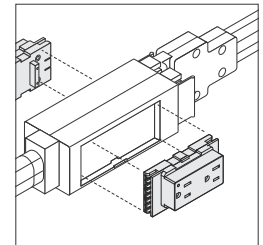
**Numbers** printed on the receptacles indicate the line number. Label on receptacle indicates which circuit the receptacle connects to, so the user can control which devices are on specific circuits.

**With the 3-circuit separate neutral system,** these designations are with letters A, B, or C as compared to 1, 2, 3, or 4 in the other systems.

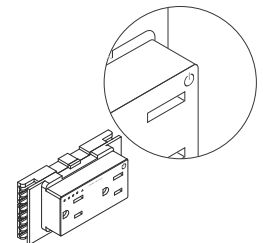
**All the components in an electrical distribution network** must use the same wiring schematic. Components are color coded and keyed to make it impossible to connect mismatched parts.

**Available** in 6000 Black plastic only.

**Receptacles** come in packages of six receptacles.



**Receptacles** snap into both faces of the powerblock in the field.



**Controlled receptacle** must be indicated when tying into the building management system. Duplex receptacles have an option for a factory permanent, pad stamp power icon symbol with the word controlled per compliance with the Energy Code.



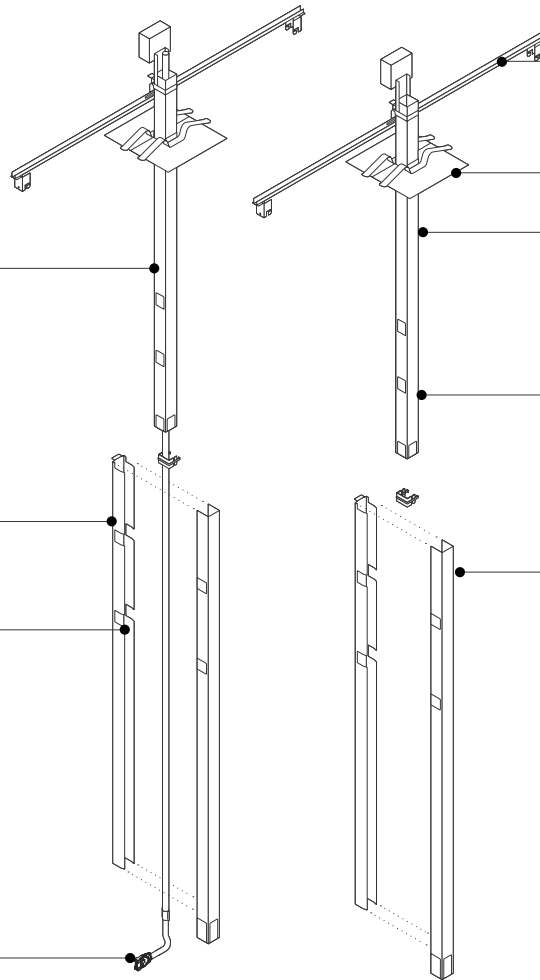
# 2" x 2" Power and Cable Pole

**Power poles** bring building power from the ceiling to the powerways in the base cavity of panels. They can also be used to run cables into the top cap or into the panel base cavity. All five wiring schematics are available.

**Trim** conceals powerway and cables routed to the base of the panel.

**Knockout**

**The power pole harness** attaches to either end of a powerway.



**Hanger bar** secures the top of the pole to the ceiling grid.

**Ceiling trim plate**

**Cable poles** provide a space to route cables from the ceiling to the high top cap or base cavity of a panel.

**Knockouts** allow data distribution in change-of-height conditions.

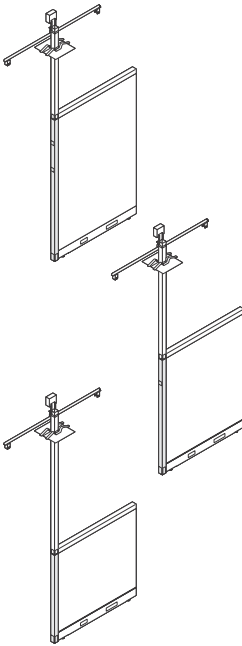
**Retainer** attaches to the end of a panel with screws that attach below the top cap. Panel remains undamaged so power and cable pole can be removed and relocated later.

**On June 19, 2023,** TEKtis power components changed design. Power components manufactured before June 19, 2023 are not compatible with power components manufactured after June 19, 2023.  
 ▶ See *Power Components Transition Details* on page 218.

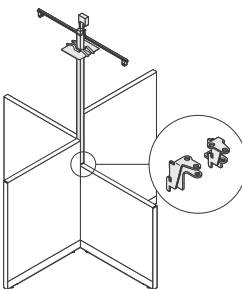
**All the components in an electrical distribution network** must use the same wiring schematics. Components are color coded and keyed to make it impossible to connect mismatched parts.

**Product Details**

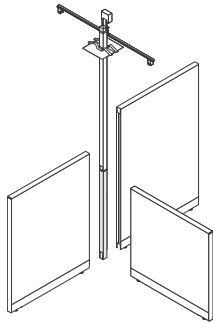
**Power and cable poles** accommodate ceiling heights up to 10'4"H.



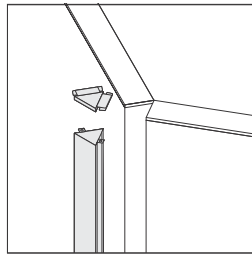
**Height of the pole** must correspond with the height of the panel it is attached to so that the pole will connect under the top cap. Adjacent panels can be lower. Ceiling heights up to 10'4" can be accommodated.



**Power and cable pole packages** ship with one left-hand and one right-hand corner change-of-height connector. A separate change-of-height package may be required in certain X configurations.



**In T configurations,** height of power and cable pole must correspond to the height of the center panel.



**120° vertical corner trim** is required for all 120° connections. The same 120° vertical corner trim is used for two- and three-way connections and is available with a low end cap only. Both two- and three-way end caps are included with each 120° vertical corner trim package.

▶ Page 252

**Surface Materials**

**Power pole**

- Paint

**Ceiling trim plate**

- 4790 Sodium paint

# Base Power-In

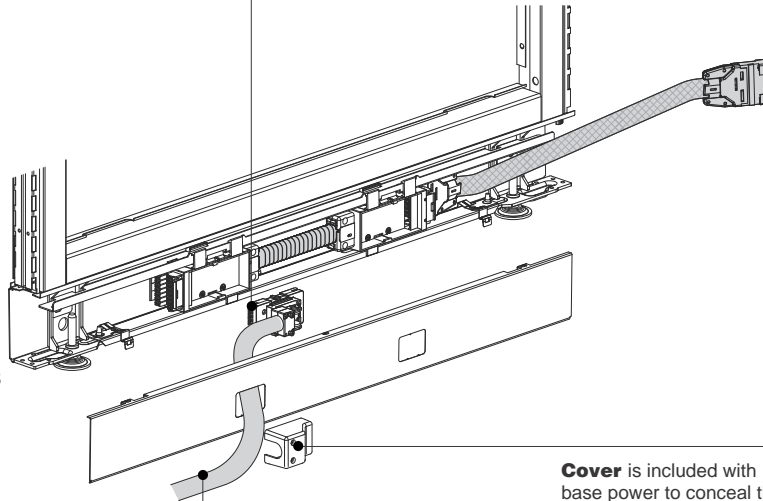
**Base power-ins** are field installed and connect the panel electrical system to the building power source.

**Power-ins** are UL listed and CSA certified. Local electrical codes vary, so consult with your local authority having jurisdiction as they have final say if the products as installed are compliant with local code.

**All the components in an electrical distribution network** must use the same wiring schematic. Components are color coded and keyed to make it impossible to connect mismatched parts. Building power source can come from the floor, wall, or column.

**On June 19, 2023**, TEKTIS power components changed design. Power components manufactured before June 19, 2023 are not compatible with power components manufactured after June 19, 2023. ▶ See *Power Components Transition Details* on page 218.

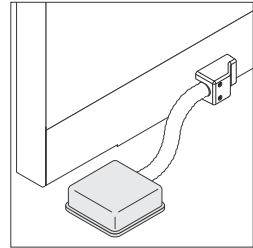
**Connector on end of base power infeed harness** occupies one receptacle location in powerblock.



**Flexible harness** secures hardwired connection to building monument. The harness must be back fed through the base trim prior to connection into the building monument.

**Cover** is included with base power to conceal the connection.

## Product Details



**Power-in** brings power to panel run by connecting to a designated receptacle location on either end of the powerway. Power-ins fit standard-size receptacle openings if the green end of the powerway is located behind the receptacle opening.

**Paint color** is required for base power-in for use in New York.



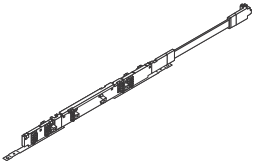
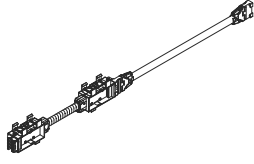
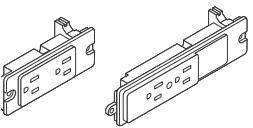

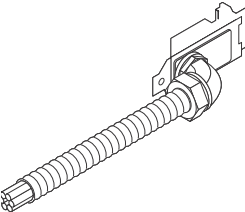
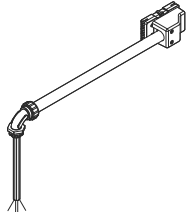
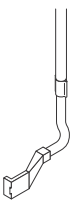
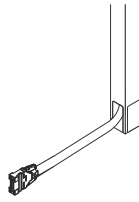
# Power Components Transition Details

On June 19, 2023, TEKTIS power components changed design. Power components manufactured before June 19, 2023 are not compatible with power components manufactured after June 19, 2023.

The style numbers of power component have changed. The panel style numbers have not changed. Any panel segment ordered with power after June 19, 2023 will include the new power component design.

How power is specified remains unchanged. Power can be optioned on to the panel segment. Powerways can be specified as installed in the factory or installed in the field.

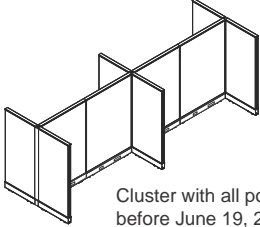
Components included in the design change are powerways, receptacles, base power-ins, and the harness included in the power pole.

Power before June 19, 2023	Power after June 19, 2023
<b>Powerways</b>	
	
<b>Receptacles</b>	
 <p data-bbox="146 1081 324 1102">Standard      Larger</p>	
<b>Base Power-Ins</b>	
	
<b>Power Harness in Power Pole</b>	
	

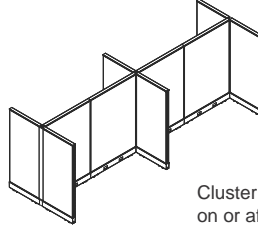
<b>Difference between power components</b>		
<b>What is different</b>	<b>Power before June 19, 2023</b>	<b>Power after June 19, 2023</b>
<b>Connector flag/harness</b>	Mesh connector flag is not removable from the powerway.	Mesh connector flag is removable from the powerway.
<b>Power access in 24" and 30" wide panel segments</b>	24"W and 30"W base covers have a standard-size opening on one side of the panel and larger size opening on the reverse side.	24"W and 30"W base covers have standard-size openings on both sides of the panel.
<b>Receptacle size</b>	Receptacles were available in two sizes– standard and larger.	All receptacles are standard size.
<b>Receptacle cutout locations on base covers</b>	Receptacle location differs before and after June 19, 2023. See details under <i>Receptacle Location Change</i> . Page 221	Receptacle location differs before and after June 19, 2023. See details under <i>Receptacle Location Change</i> . Page 221
<b>Base power-in</b>	Connection at receptacle location does not include an aesthetic cover.	Connection at receptacle location includes an aesthetic cover.
<b>Receptacle connection to powerway</b>	Receptacle connect to powerway with screws.	Receptacle snaps into the powerway without any screws.
<b>Wiring schematics</b>	All five wiring schematics available. Color-coding and keying have changed.	All five wiring schematics available. Color coding and keying have changed.

**Planning with power components manufactured before and after June 19, 2023.**

Power components manufactured before June 19, 2023 can still be used but do not connect to power components manufactured on or after June 19, 2023. The following two approaches can be used when both power systems are used:

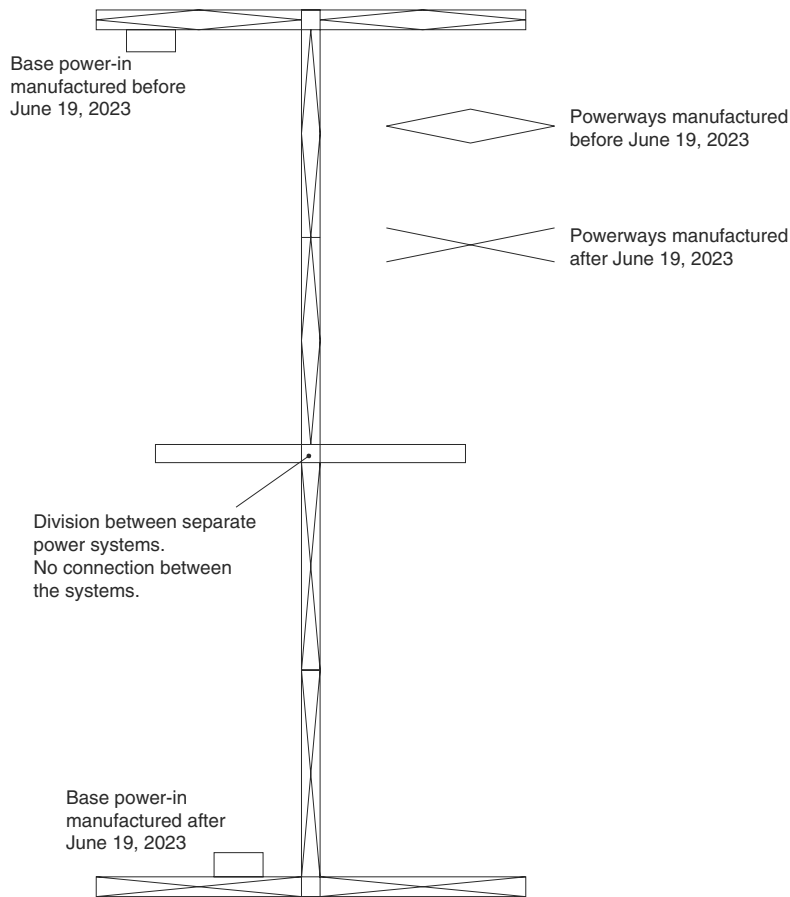


Cluster with all power components manufactured before June 19, 2023.



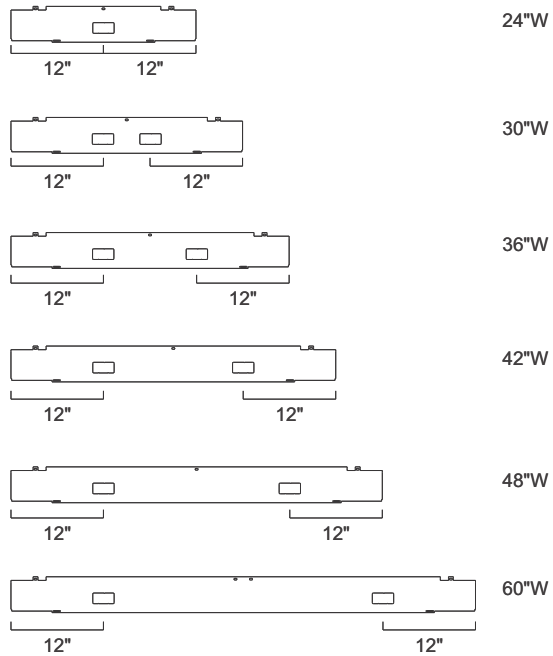
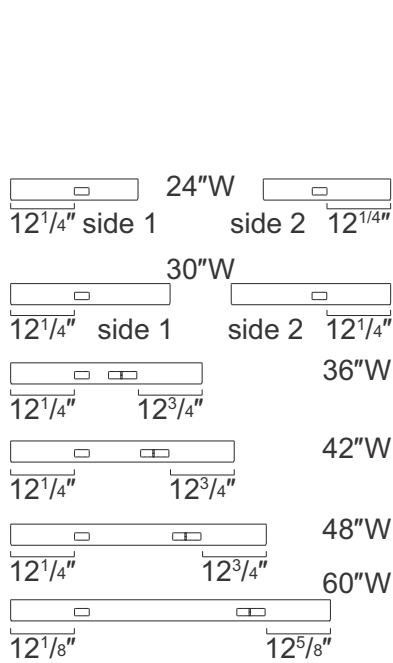
Cluster with all power components manufactured on or after June 19, 2023.

Organize by cluster: Power systems can be organized by workstation cluster. Some clusters can use power components manufactured before June 19, 2023 and other clusters can utilize power components manufactured on or after June 19, 2023.



Utilize multiple infeeds in a single cluster: A single workstation cluster can use both power systems by utilizing multiple infeeds. Power components manufactured before June 19, 2023 can power part of the workstation and have its infeed and power components manufactured on or after June 19, 2023 can power part of the workstation and have its infeed. Each power system covers part of the workstation and the two systems do not connect to one another.

**Receptacle location change**



**Receptacle location for base Trims manufactured before June 19, 2023**

**Receptacle locations for base trims manufactured after June 19, 2023**

**Status of power components manufactured before June 19, 2023**

Powerways, panel connectors, receptacles, base power-ins and harnesses included in the power pole manufactured before June 19, 2023 are no longer supported.

Basecovers with receptacle cutouts for the receptacle locations of the pre-June 19, 2023 powerways are supported as service parts.

Receptacle knockout fillers for both the pre-June 19, 2023 and post-June 19, 2023 are available as a service part.

The pre-June 19, 2023 wire separator, which supports the powerway in the panel, is available as a service part.

**How to convert a TEKTIS panel manufactured before June 19, 2023 with post June 19, 2023 power components.**

1. Remove all pre-June 19, 2023 power components and the pre-June 19, 2023 wire separator.
2. Order from service parts a post June 19, 2023 wire separator, a post June 19, 2023 powerway and a post June 19, 2023 set of base covers of the appropriate width. Powerways, wire separators, and base covers are not available as style numbers.
3. Add post June 19, 2023 components to base area of the panel frame manufactured before June 19, 2023.

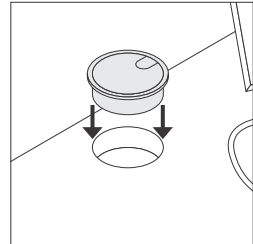
# Worksurface-Height Grommet

**Power** can be accessed at or near worksurface height by using a grommet.



**Grommet**

## Product Details



**Grommets** are available in packages of 10 to finish exposed edges of field-installed openings in the worksurface for vertical cable routing.

**Grommets** are available in black plastic only.



# Worksurfaces

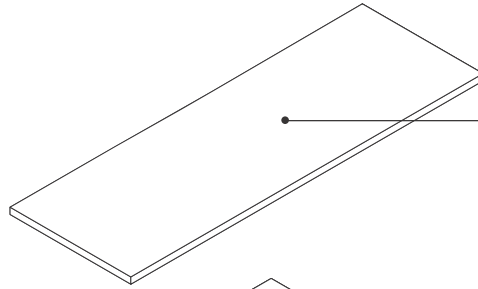
**Worksurface** has a wood core with laminate top and plastic edge band. Low-Pressure Laminates are available. Plastic edge band color is selectable.

**Systems worksurfaces —with 1/2" cord drop** feature built-in cable management flexibility, allowing cords to drop below the worksurface at any point along the back edge.

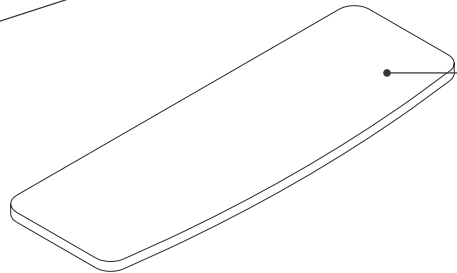
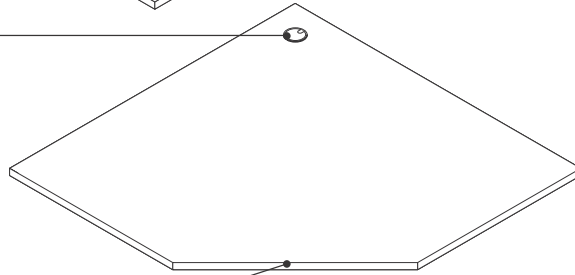
**Systems worksurfaces —full depth** feature a tighter fit to panels for a cleaner aesthetic.

**Grommet** is standard on corner worksurfaces only. Field-installed grommet requires a 3" diameter hole in the worksurface.

**Front (user's) edge** is a plastic edge band with a 3 mm radius. Back and side edges are flat.

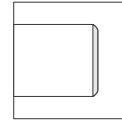


**Full-depth worksurfaces** fit flush against panels.



**Worksurface** has a wood core with a Low-Pressure Laminate surface and is 13/16" thick.

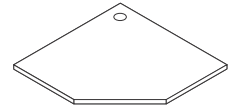
## Product Details



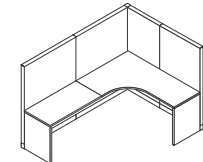
3 mm edge profile

**PVC-free, 3 mm edge profiles** are proprietary polyolefin blend for all solid colors and seven woodgrain finishes. Matching 1 mm side and back edges are also PVC-free.

**Edge profile finishes** are specified separately from laminate color.

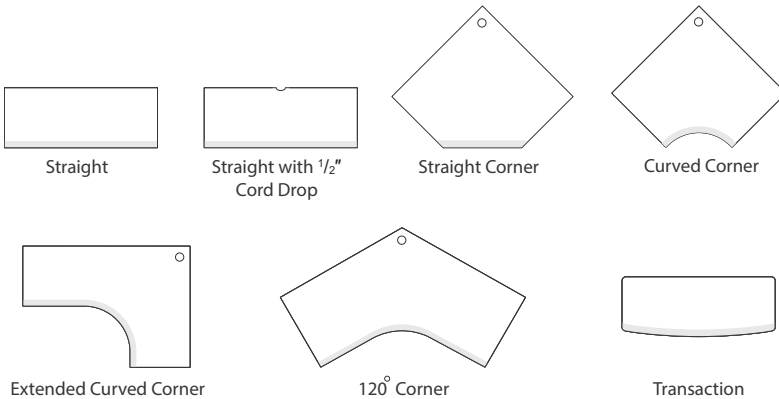


**Corner bracket** is included to connect the back corner of worksurface to panels.



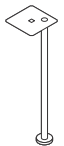
**30"D straight cantilevered worksurfaces** require additional floor support along the front edge, such as a pedestal, end panel, post leg, side support bracket, or an adjacent return worksurface.

## Edge Profiles

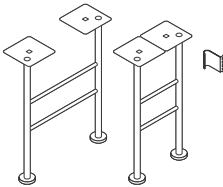


**Edge Profile** is applied to front (user's) edge only.

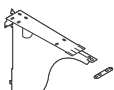
**Connections**



Post leg



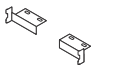
H-leg with bracket



Cantilever with tie plate



Universal Cantilever with tie plate



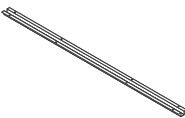
Side support brackets



Tie plates



In-line support plate



Reinforcing channel

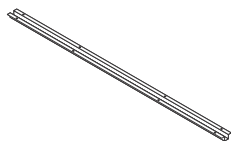


End panels—standard height

**Supports** are ordered separately and installed in the field. The following supports are available for use with worksurfaces:

- Post leg
- H-leg
- Cantilever with tie plate
- Universal cantilever with tie plate
- Side support brackets
- Tie plates
- In-line support plate
- Reinforcing channel
- On-module end panel

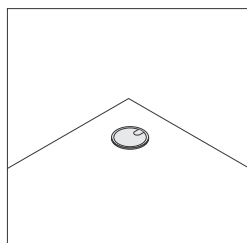
**Cantilever with tie plate** works in left-hand, right-hand, or shared applications.



**Worksurface spans greater than 54"** require additional support of a cantilever, pedestal, intermediate support, or leg. Exception; worksurfaces can span up to 60" in heavy load applications and up to 72" in light load applications if a reinforcing channel is used. Reinforcing channel must be specified separately.

▶ Specifying, page 260

**Wiring & Cabling**



**Grommet** is standard on corner worksurfaces.

**Surface Materials**

**Low-Pressure Laminate Worksurfaces**

- Laminate

**Front (user's) edge(s)**

- Plastic

**Back and side edges**

- Plastic color default to match user's edge



Straight



Straight corner



Curved corner



Left-hand extended curved corner



Right-hand extended curved corner



120° Corner

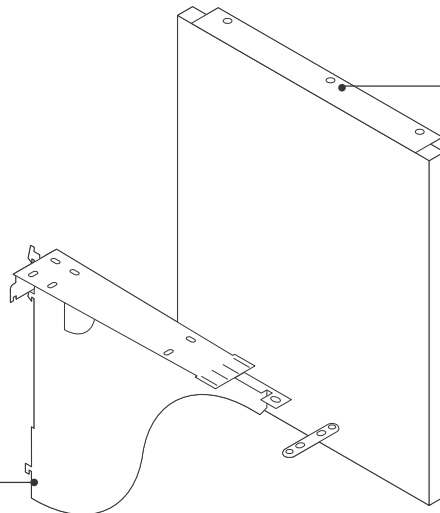


Transaction

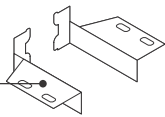
**Worksurfaces** are available in a wide variety of worksurface shapes. Directional laminate grain direction is shown.

# Worksurface Legs and Supports

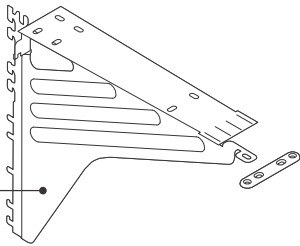
**On-module supports** can be used to panel support worksurfaces in various configurations.



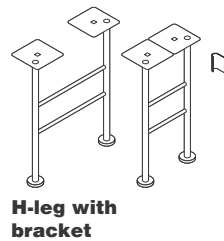
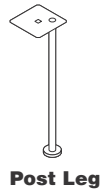
**Cantilever** can be used to panel-support a worksurface at any height.



**Side support brackets** can be used to support the ends of straight and corner worksurfaces and to support the back corner of any corner worksurface.

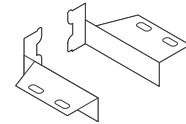


**Universal cantilever** features alignment tab used to set a depth for straight worksurfaces with 1/2" cord drop. This tab is bent down when installing full-depth worksurfaces.

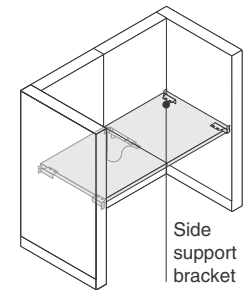


## Product Details

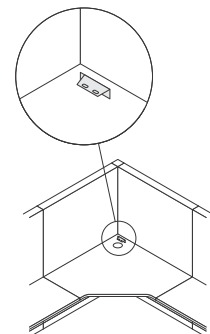
**On-module worksurface supports** engage the slots in the vertical uprights of panels.



**Side support brackets** support worksurfaces at any height in 1" increments. Brackets ship as a left- and right-hand pair and are ordered separately.



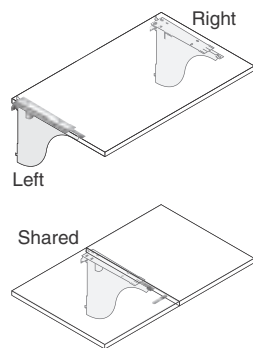
**Side support brackets** can be used to support the end of a worksurface that is wrapped by a panel with the same width dimension that matches the worksurface depth.



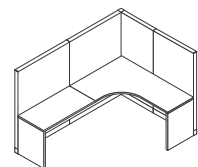
**Single side support bracket** can be used to support the rear corner of corner, extended corner, and 120° corner worksurfaces. It is standard with these corner worksurfaces.

## Actual Dimensions

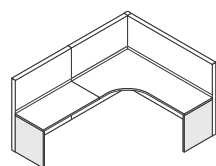
	Universal cantilever	Cantilever	End panel	Post leg	H-leg
Height	12¼"	13"	28½"	28½"	28½"
Depth	15½"	16"	23¾" or 29¾"	N.A.	14" or 22¾"
Glide Range	N.A.	N.A.	1¼"	2"	2¾"



**Cantilevers** support worksurfaces at any height in 1" increments. Cantilever is non-handed and can be used to support either end of a worksurface, or shared to support two worksurfaces at the same height simultaneously. One tie plate ships with each cantilever.



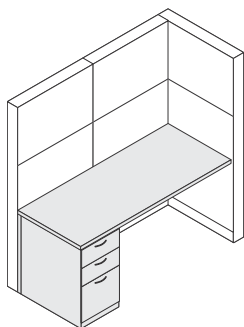
**30°D straight, cantilevered worksurfaces** require additional floor support along the front edge, such as a pedestal, end panel, post leg, side support bracket, or an adjacent return worksurface.



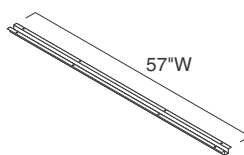
**End panels** can be used to support the end of a worksurface for additional panel stability. Refer to the applicable panel stability guidelines for specific requirements.  
▶ See page 200

**End panels** are available in seated height, and cannot be used in freestanding applications.

**All panel mounted supports** can be removed and repositioned later without any permanent damage to panels or skins.



**Pedestals and lateral files with a filler** can be used to support the end of a worksurface in place of an end panel.



**Worksurface spans greater than 54"** require additional support of a cantilever, pedestal, intermediate support, or leg. Exception; worksurfaces can span up to 60" in heavy load applications and up to 72" in light load applications if a reinforcing channel is used. Reinforcing channel must be specified separately.  
▶ Specifying, page 377

### Surface Materials

#### Side support bracket and reinforcing channel

- Black paint only

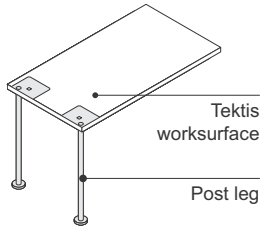
#### Cantilever, post leg, and end panel

- Paint

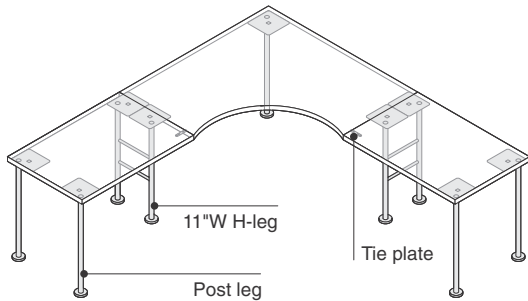
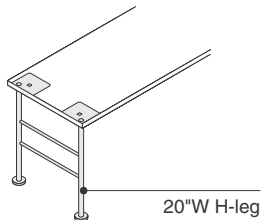
# Freestanding Guidelines

For TEKTIS Worksurfaces with Legs

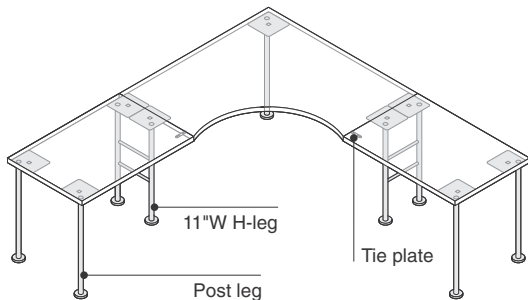
The following section on freestanding worksurfaces gives some guidelines to be used with common freestanding configurations. Consult your local dealer or AMQ representative prior to deviating from these guidelines.



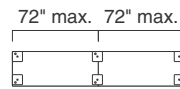
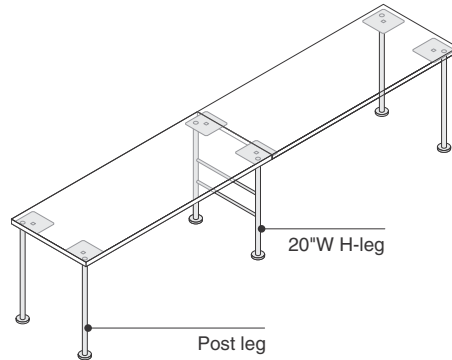
**With post legs.**



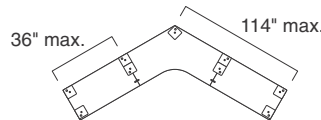
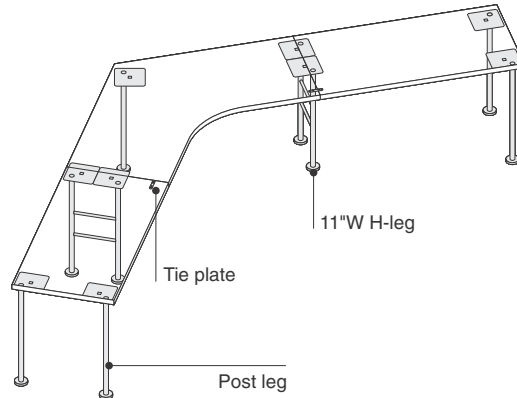
**Combined worksurfaces** can give each other support when joined with an 11"W H-leg and tie plate.



**Corner workstation** attached to adjacent worksurfaces requires 11"W H-leg. Tie plate is recommended to align worksurfaces. This application only good for 48"W corner worksurfaces. The 36"W and 42"W corner worksurfaces do not meet ADA requirements.



**20"W H-leg** can support adjacent worksurfaces up to 72"W.



**120° workstation.**

**H-leg** can be used to support adjacent perpendicular worksurfaces up to 72"W.

**Reinforcing channel (AMQTSATRC)** is available to add support to worksurfaces that have 60" or more of unsupported kneespace and that are heavily loaded.

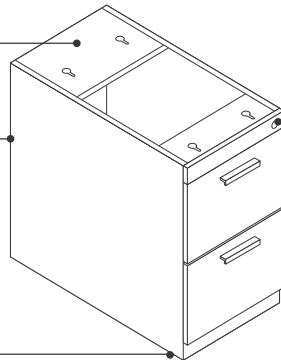


# Pedestals

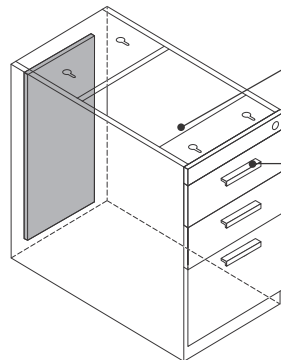
**Pedestals** provide fixed storage for personal items and filing of infrequently referenced materials.

**Top of pedestal** is open to attach beneath the worksurface.

**Finished back and sides** are standard.



**Leveling glides on pedestals** adjust to install furniture on uneven floors. Leveling glide range is 1".



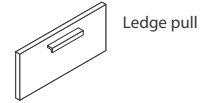
**Locks** ship with a lock face ring and removable plastic plug to accommodate a lock cylinder installed on site.

**Standard lock cylinders and keys** are included with TEKTIS pedestals. If a master key is specified, **AMQLOCK9201XF** must be specified to be included.

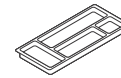
**Interlocks** allow only one drawer to be opened at a time and can be required for safety and stability purposes.

**Ledge pulls** are available on drawers.

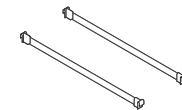
## Product Details



**Ledge pulls** are available on drawers.



**Pencil tray for use with fixed pedestals** are included and available as an option.



**To file legal-size or side-to-side letter-size filing in pedestal file drawers**, rails are included with pedestals and available as an option.

**Counterweight packages and interlocks** may be required to ensure stability and must be ordered separately.

► Page 274

## Actual Dimensions

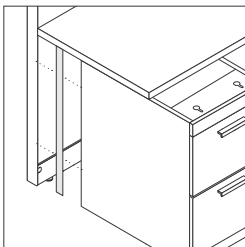
### Fixed Pedestals

Depth	21 <sup>3</sup> / <sub>16</sub> ", 27 <sup>13</sup> / <sub>16</sub> "
Width	15"
Height	27"

## Connections

**Fixed pedestals** are intended for use under a panel-mounted worksurface. Attachment hardware is provided.

**Tektis fixed pedestals** cannot be converted to a freestanding pedestal using a pedestal conversion kit.



**Pedestal filler**, ordered separately, adds structure and fills the gap between the pedestal and panel. Pedestal filler works with panels only.  
▶ Page 274

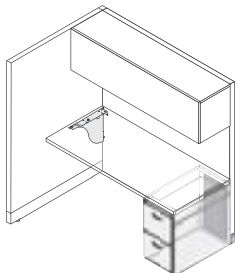
**Additional supports** are required if worksurface overhang is 7" or larger.

## Stability

**Counterweights** are required for single desk applications, including when a Tektis fixed pedestal is paired with a worksurface and floor supports for a standalone desk application.

**Panel stability guidelines** must be met prior to determining counterweight requirements. Refer to stability guidelines on page 206.

**Counterweights** are not required for fixed pedestals installed below a worksurface attached in a panel spine application. With the exception of single workstation applications which require a counterweight in each pedestal (**AMQTS2CW**).



**Interlocks** are required when using a Tektis fixed pedestal with a single pedestal desk, 48"W and below require an interlock. Single pedestal desks with 28"D pedestals also requires an interlock (**AMQTS2INT**).

## Wiring & Cabling

**Fixed pedestals** do not accommodate cable-routing. Plan accordingly when installing pedestals underneath worksurfaces with grommets of other cable-routing accessories.

## Surface Materials

### Pedestals

#### Case

- 4799 Platinum Metallic
- Ledge pull** (default)
- 4799 Platinum Metallic

#### Case

- 7207 Black
- Ledge pull** (default)
- 7207 Black

#### Case

- 7243 Seagull
- Ledge pull** (default)
- 4799 Platinum Metallic

## Shipping

**Fixed pedestals** are normally shipped in heavy-duty, recyclable stretch wrap to reduce the amount of corrugated board needed.

# Bins

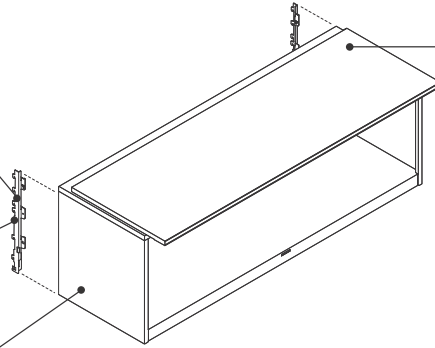
**Bins** can be attached to TEKTIS with integrated hooks. These storage bins provide overhead storage in the workspace.

**On-module attachment hooks** are integral to the end supports and are used to mount bins on panels of the same width as bins.

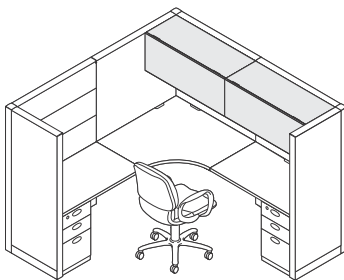
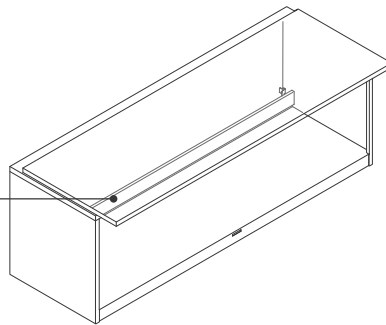
**Safety catch** locks overhead storage unit to frame to prevent accidental removal.

**Bin** is steel and ships assembled.

**Backstop** prevents notebooks and equipment from damaging the surface of the panels or walls.



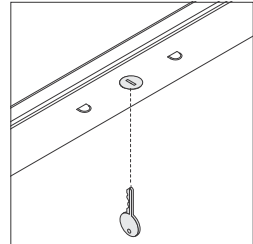
**Flat-front lift-up doors** open and close quietly. When up, the doors rest on top of the case to provide more storage space inside.



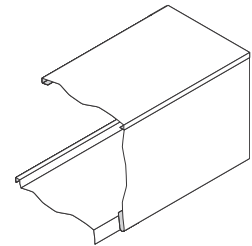
## Actual Dimensions

<b>Depth</b>	15 <sup>3</sup> / <sub>4</sub> "
<b>Width</b>	24", 30", 36", 42", 48", 60", or 72"
<b>Height</b>	16 <sup>1</sup> / <sub>4</sub> "

## Product Details



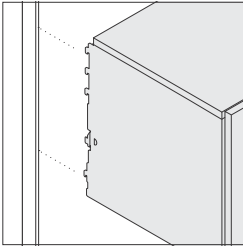
**Lock in bin** is concealed from view beneath the shelf. Field-installed locks are standard with random keying options. Master-keyed locks are also available. **AMQLOCK9201XF** must be specified separately. ▶ *Lock and Keying*, page 380



**Back of storage bin** is open to allow panel surface to show. Metal backstop prevents contents of bin from damaging panel surface.

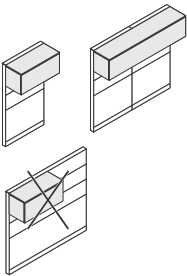
**Overhead storage bin height** accepts standard and A4 binders.

**Connections**

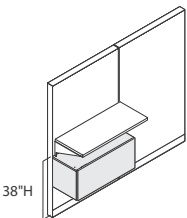


**Steel support hooks on end** supports insert into the slotted channel of a panel or wall channel and lock into place with a safety catch.

**On-module steel support hooks** can be used above and adjacent to TEKTIS panels.



**Width of overhead bin** must match the width of the panel or panels that it is attached to. Bin may span up to two frames.



**Bin** may be mounted at 38"H or lower if another panel-mounted component prevents it from being seated upon.

**Bins** cannot be attached to upmount brackets.

**Surface Materials**

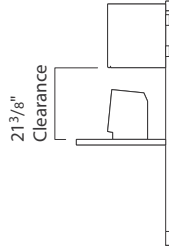
**Overhead bin**

- Paint

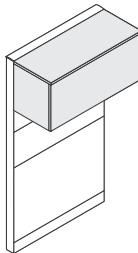
**Lock**

- 9201 Polished Chrome

**Application Topics**

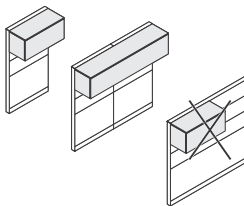


**Clearance between work surfaces and bottom of overhead bins** is 21<sup>3</sup>/<sub>8</sub>" when storage unit is installed in the highest position on a 66"H panel and glides are adjusted all the way into the panel.



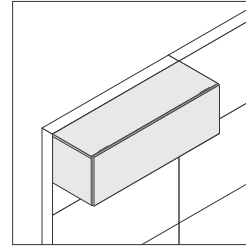
**On-module brackets and hooks** are used to mount overhead bins and common shelves to panels with vertical slot patterns. Panels can support on-module attachment brackets.

**Common shelves** can attach on-module to panels.



**Width of overhead storage unit** must match the width of the panel or panels that it is attached to. Storage bins or shelves may span up to two panels.

**Additional support for stability** may be required when shelves and overhead storage bins are attached to panels. Loads on the opposite sides of the panels increases stability.



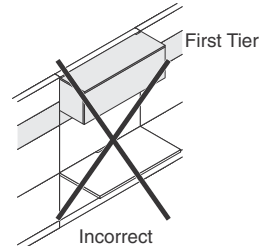
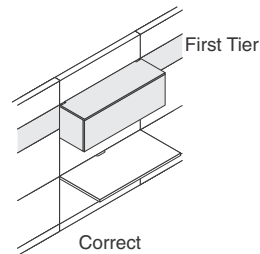
**On-module attachment brackets** install in panel seams.

**On-module brackets** can be used with a panel stacker on panels. Follow standard panel stacker guidelines for each panel.

**Stability Guidelines**

▶ Page 200

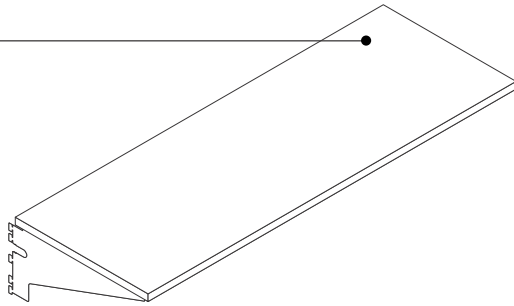
**Guidelines for Stackable Components**



**Bins and shelves** can hang from the first stacked tier only.

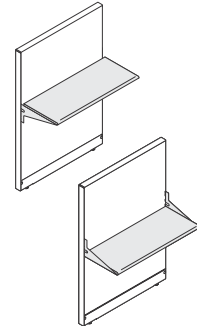
# Laminate Common Shelves

**Laminate common shelf** has a wood core and is covered with Low-Pressure Laminate. Plastic edge band is selectable.  
*Tip: For anticipated heavy loads on 42" and 48"W laminate common shelves, a field-installed reinforcing channel (AMQTSATRC) can be used.*  
 ▶ page 258

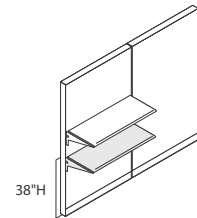


Laminate common shelf

## Product Details



**Laminate common shelf** ships with steel support brackets. Support brackets hook into the vertical panel slots or wall channel and lock into place with a safety catch. Support brackets can be used in either orientation.



**Shelf** may be mounted at 38"H or lower if another panel-mounted component prevents it from being seated upon.

## Surface Materials

### Shelf

- Laminate

### Edge

- Plastic

### Supports

- Paint

## Actual Dimensions

<b>Depth</b>	15"
<b>Width</b>	24", 30", 36", 42", or 48"
<b>Height</b>	7 <sup>3</sup> / <sub>4</sub> "

# Wall Hang Channels and Horizontal Braces

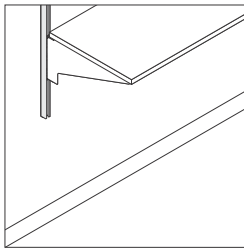
For Use with Overhead Storage Bins and Shelves

Wall Hang Channels and  
Horizontal Braces

**Slotted steel channel** can attach to wall of building to accept shelves, overhead storage bins, or worksurfaces. Channel will accept all universal bins and shelves, TEKTIS bins and shelves introduced prior to March 2007.

► Specifying, page 377  
Tip: Must specify bin or shelf with TEKTIS bracket to hang on wall channel.

## Product Details



**Wall channel** can be positioned on wall at height needed.

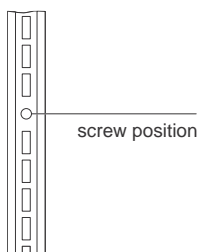
## Connections

**Wall channels** can be used to support shelves, overhead storage bins, or worksurfaces. Wall channels can be shared.

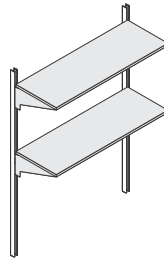
## Field install:

- Concrete walls with Hilti type anchors.
- Drywall or plywood with 5/8" thick Toggler R-type 3/16" wall anchors with countersunk flat head screw.
- Steel or wood studs with #10 sheet metal or wood screws of appropriate length with countersunk flat head screw.

**Anchors** must be used in each screw hole location on the wall channel.

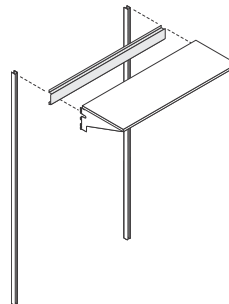


**Components attach** at 1" increments, but screws block some slot locations.

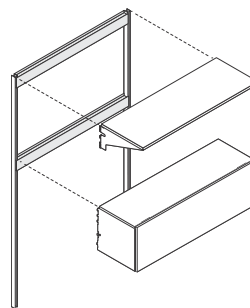


## Component limits for each pair of wall channels

- Two bins or shelves
- One worksurface and two shelves
- One worksurface and one bin



**Horizontal brace** is available to reinforce vertical wall channels that support storage bins, shelves, or worksurfaces that are attached to walls. Bins and shelves that are 48"W or less do not require a horizontal brace. All worksurfaces require horizontal braces.

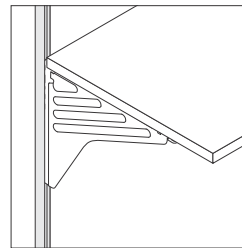


**Wall channel horizontal brace** is required for EACH storage bin or shelf that is wider than 48". The brace should be placed at the position along the vertical wall channel where the top of the bin or shelf will be placed.

**Width of horizontal brace** must match width of shelf or storage bin.

**Wall channel horizontal brace** is also available in 42" and 48" widths and can be used in applications where there is concern regarding the strength of the wall. These braces must also be used with wall-mounted worksurfaces.

**Wall hang channels** for shelves or overhead storage bins cannot be used with a wall start junction.



**Worksurfaces** may be attached to wall channels with cantilevers, subject to the following application guidelines:

- All worksurfaces must be 24"D or less.
- Worksurfaces must be supported by a cantilever or legs every 42" or 48". Cantilevers can be shared when worksurfaces are adjacent.
- Wall channel horizontal braces must be installed directly behind all wall-mounted worksurfaces, and also at the top of the wall channels.
- Worksurface-supported pedestals cannot be hung from a wall-mounted worksurface.

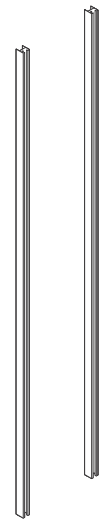
## Surface Materials

### Wall channel

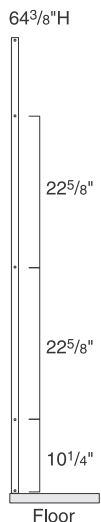
- Paint

### Horizontal brace

- Paint



## Screw hole positions



## Actual Dimensions

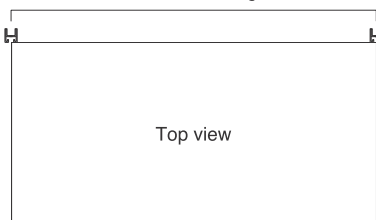
### Wall hang channels and horizontal braces

Depth	1 1/8" (28 mm)
Width	15/16" (24 mm)
Height	66" (1676 mm)

## Application Topics

**Reinforce** wall by positioning studs where wall channels will be attached. See dimensions below.

Distance between center lines of reinforced wall channels matches width of overhead storage unit.



Tip: Wall channels can be shared.

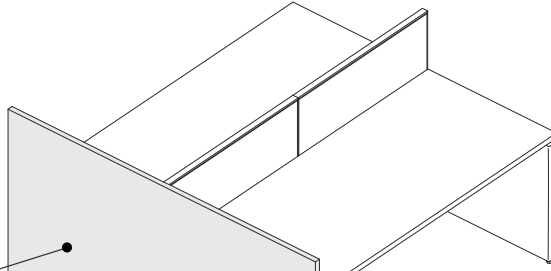
# Boundary Screens

**Boundary screens** have a thin profile and provide light scale space division and visual boundary.

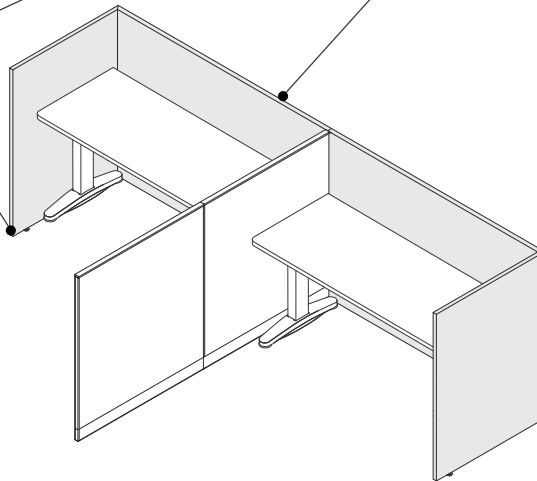
**TEKTIS boundary screens** attach to the TEKTIS panel at end-of-run and middle-of-run junctions.  
 ▶ Specifying, page 278

**Screens** are available in classic woodgrain or solid laminates.

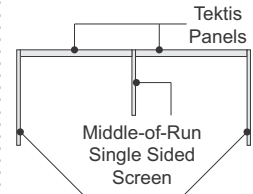
**Boundary screens** come standard with adjustable glides, with a range of 1½". The glides are located 3" from the outside of each edge.



**TEKTIS boundary screens** have a thickness of 1⅜".

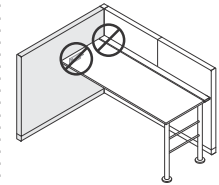


## Product Details



End-of-Run Single Sided Screens

**Boundary screens** can connect to panels at the end-of run junction and middle-of-run junction.



**Boundary screens** cannot be used as a support in place of a leg, pedestal, or other worksurface support.

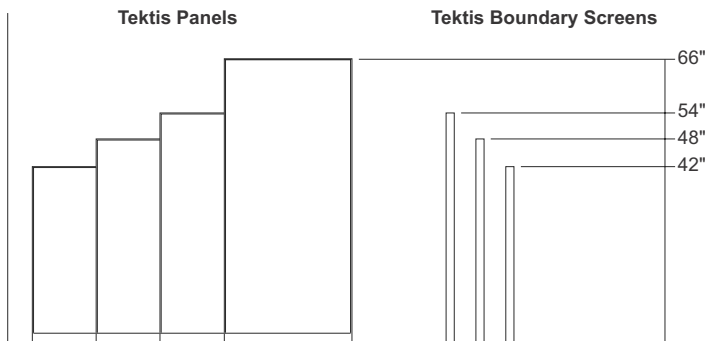
**Screens** are made of 1⅜" board with Low-Pressure Laminate.

## Actual Dimensions

<b>Height</b>	28½", 42", 48", or 54"
<b>Single-Sided Width*</b>	26", 26½", 32", 32½", 38", 38½", 44", 44½", 50", 50½", 56", 56½", 62", 62½", 74", or 74½"
<b>Spanning Width*</b>	50", 53", 62", 65", 74", or 77"
<b>Split Width per Side*</b>	49", 49½", 55", 55½", 61", 61½", 73", or 73½"
<b>Return Width*</b>	25⅜" and 31⅜"
<b>Thickness</b>	1⅜"

\* Dimensions above include extra inches of trim when connecting to a panel.

Tip: 28½"H boundary screens are available for end-of-run junctions for spanning and split boundary screens.



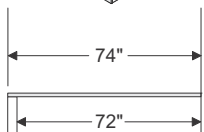
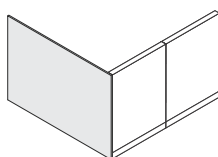
**Boundary screens** have modular heights and widths.

Note: TEKTIS panels are available in 66"H, but TEKTIS boundary screens are not available in 66"H.

**Boundary screen heights** align with thin trim top cap panel heights at 42", 48", and 54". 28½"H boundary screens are also available for end-of-run junctions for spanning and split boundary screens.

**TEKTIS boundary screens** are available in six different configurations.

**1. Single-sided boundary screens** provide boundary to one side of a TEKTIS panel and are specified either as left or right. Available in end-of-run and middle-of-run configurations.

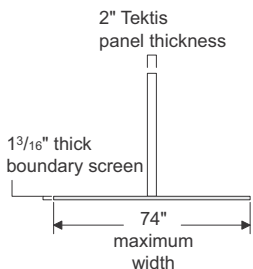
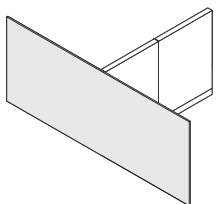


2" Tektis panel thickness

**Single-sided boundary screens** will always include the 2" thickness of the TEKTIS panel to which they attach. For a 72" width screen (72"W inside, +2"W for the TEKTIS panel thickness for a maximum of 74"W). The above is shown with a right-handed screen application.

*Tip: The above image shows a 72" specified width. The planning width is 74".*

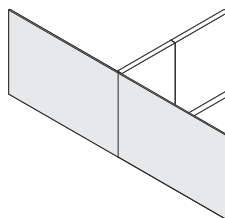
**2. Spanning boundary screens** use one screen segment to provide boundary of equal widths to both sides of a TEKTIS panel. Available in end-of-run and middle-of-run configurations.



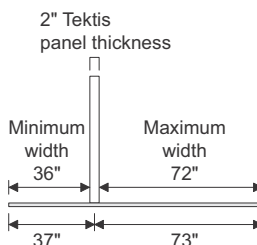
**Spanning boundary screens** will always extend in equal dimension from the panel to which it attaches and include the 2" thickness on the TEKTIS panel.

**For a 48"W spanning boundary screen** (48"W inside, and 2" for the TEKTIS panel thickness for a total of 50"W minimum). For a 72"W spanning boundary screen (72"W inside, and 2" for the TEKTIS panel thickness for a total of 74"W maximum).

**3. Split boundary screens** use two screen segments to provide boundary to both sides of a TEKTIS panel. Both sides of a split boundary screen must be the same height. Available in end-of-run and middle-of-run configurations.



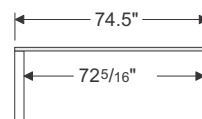
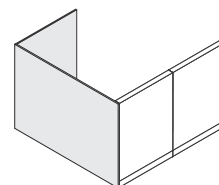
**Split boundary screens** can either be equal or asymmetrical in dimension from the TEKTIS panel to which they attach and include the 2" thickness of panel in total.



**For a 36" width split** (36"W inside, and 1" for half of a TEKTIS panel thickness for a total of 37"W minimum) for each side of the panel. For a 72" width split (72"W inside, and 1" for half of a TEKTIS panel thickness for a total of 73"W minimum) for each side of the panel.

*Tip: The above image shows a 37" specified right width and a 73" specified left width. The planning right width is 36" and the planning left width is 72".*

**4. Single-sided L return boundary screens** provide boundary and additional privacy to one side of a TEKTIS panel. Both screen segments (primary and return screen) are the same height and are specified as either left or right-handed.

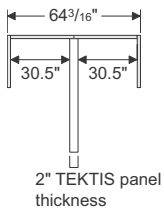
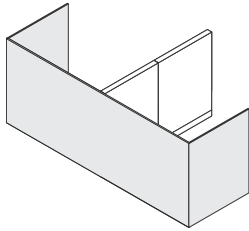


2" Tektis panel thickness

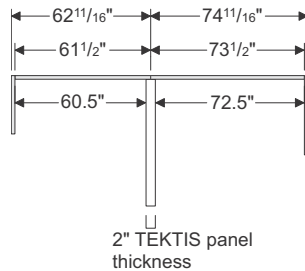
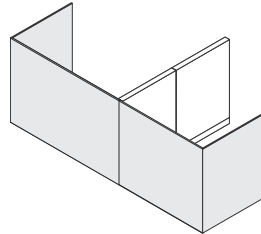
**Single-sided L return boundary screens in modular widths** have inside clearance in 6" increments to wrap standard width worksurfaces in 6" increments. Panel connected segments (the primary screens) are available in widths of 27" (24" inside, return width 27", and 2" for TEKTIS panel thickness) to 75" (72" inside, and 2" for TEKTIS panel thickness). The inside width of modular returns are 24" or 30". There is an additional 1 3/16" that will be added to the return width for the primary screen thickness. Both boundary screens have equal heights and are specified as either left or right handed.

*Tip: The above image shows a 75" specified width. The planning width is 72".*

**5. Spanning L return boundary screens** provide boundary and additional privacy to both sides of a TEKTIS panel. Both screen segments (primary and return screen) are the same height. Spanning L configuration screens and returns must have symmetrical widths.



**6. Split L return boundary screens** consist of four segments to provide boundary and additional side privacy to both sides of a TEKTIS panel. Split L configuration screens do not have to have symmetrical widths but must have the same height.



**Split L return boundary screens in modular widths** have inside clearance in 6" increments to wrap standard width worksurfaces from 24" to 72" in 6" increments for each side of the split. The inside width of modular returns will be 24" or 30". There is an additional <sup>1</sup>/<sub>32</sub>" that will be added to the return width for the primary boundary screen thickness. Each panel connected segment is available in widths from 25<sup>1</sup>/<sub>2</sub>" (24" inside, and 1<sup>1</sup>/<sub>2</sub>" for half of the TEKTIS panel thickness) to 73<sup>1</sup>/<sub>2</sub>" (72" inside, and 1<sup>1</sup>/<sub>2</sub>" for half of the TEKTIS panel thickness).

*Tip: The above image shows a 61<sup>1</sup>/<sub>2</sub>" specified left width and a 73<sup>1</sup>/<sub>2</sub>" specified right width. The planning left width is 60" and the planning right width is 72".*

## Connections

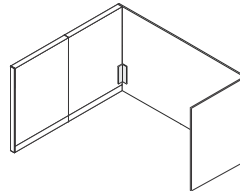
**Boundary screens** cannot be taller than the TEKTIS panel they attach to.

**End-of-run single-sided boundary screens** must always attach either at the height of the base panel or the height of the base panel with stackers.

**End-of-run spanning boundary screens and end-of-run split boundary screens** can be shorter than the height of the base panel and base panel with stackers.

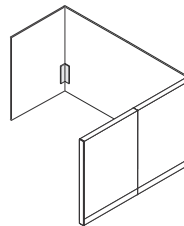
**Boundary screens at the end-of-run junction** may be shorter than connecting TEKTIS panel. In this situation, specify change-of-height trim separately (width the exception of single-sided.)

**All middle-of-run boundary screens (single-sided, spanning, and split)** must be attached to a base panel or base panel with stacker at the same height.



**On spanning and split boundary screens**, a metal plate is used to cover the bracket that connects the boundary screen to the panel. The cover is located 12<sup>1</sup>/<sub>8</sub>" from the bottom of the screen and is 3<sup>5</sup>/<sub>8</sub>"W and 13<sup>1</sup>/<sub>2</sub>"H.

**Middle-of-run boundary screens** add an additional 1<sup>3</sup>/<sub>16</sub>" to the overall panel run.



**Return segments** have a metal plate that covers the connection the return screen to the primary screen segment.

**In spanning and split boundary screen junction**, no worksurface supports (i.e., cantilever, pedestal, end panel) under 28"H can be used with the TEKTIS panel with the exception of side-support brackets.

**In single-sided applications**, all worksurface support brackets may be used on the panel channel cantilever, pedestal, end panel, etc.

## Surface Materials

**Boundary screens:**

- Laminate

**Edge on laminate:**

- Plastic

**Bracket cover:**

- Paint

*Tip: When specifying the paint finish for the bracket, select a finish that compliments the selected laminate finish.*

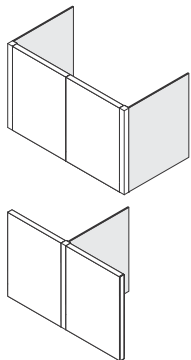
**Grain direction rules:**

**Boundary screens less than 60" wide** can have vertical or horizontal grain direction. Boundary screens 60" wide or larger must be horizontal.

**For a split with one side greater than 60"W**, both sides of the split screen must have a horizontal grain direction.

**All boundary screen sides** will have the same finish applied.

**Application Topics**



**Middle-of-run screens** cannot attach on anything higher than a 54"H base panel.

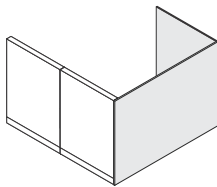
**TEKTIS boundary screens** fulfill the same stability requirements as TEKTIS panels of the same heights and widths. TEKTIS boundary screens do not support hang-on components.

▶ See *Stability Guidelines*, page 200

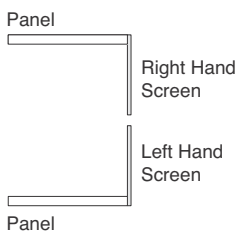
**Boundary screens** can attach to panels with fabric stacker and glass stacker application.

**Boundary screens** are not for use with wall starts.

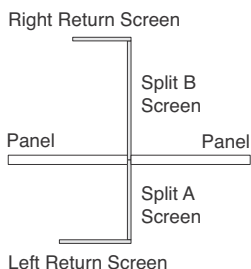
**Boundary screens with returns** cannot be used in a free-standing application. Boundary screens must be attached to a corresponding TEKTIS panel.



**End-of-Run Single Sided Boundary Screen**

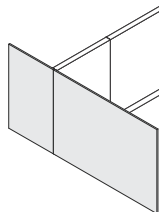


**End-of-Run Split Boundary Screen**

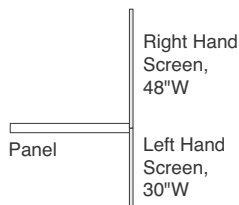


**Single-sided and split boundary screens** are available left and right handed. This is determined by the user facing the attaching TEKTIS panel.

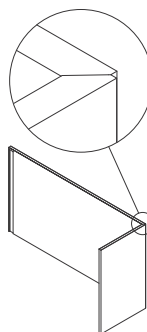
*Tip: For split boundary screens with returns, returns do not have to mirror the opposite screen.*



**End-of-Run Split Boundary Screen**



**Split boundary screen widths in both end-of-run and middle-of-run configurations** do not have to be symmetrical.



**All L-return boundary screens** have a step miter detail at the adjoining edge.

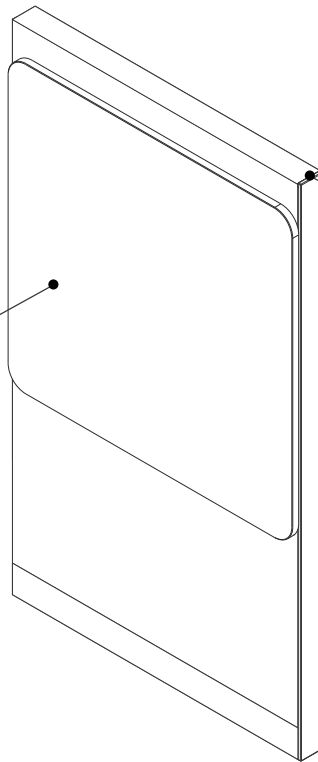
# Hanging Markerboard

## Hanging markerboard

can be added to TEKTIS panels and is a writable surface that provides visual display and invites collaboration.

► Specifying, page 286

**Markerboards** are non-magnetized.



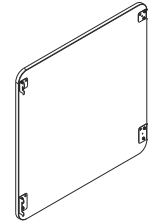
**On-module attachment hooks** are used to mount markerboards on panel(s) of the same width.

## Product Details

**Clearance** needed between worksurface and bottom of markerboard is 1 1/8".

**Width of markerboard** must match the width of the panel or panels that it is attached to. Markerboards may span up to two panels.

**Hanging markerboard** can attach to TEKTIS wall channel with a horizontal brace.



**Four hooks** must be attached on each corner of the markerboard.

## Actual Dimensions

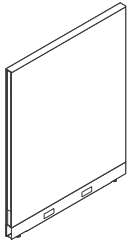
**Height** 24"

**Width** 24", 30", 36", 42", 48", and 60"

**Thickness** 1/2"

# Tackable Acoustical Panels

Tackable Acoustical Panels



Tip: Factory-included powerway for field installation option replaces need to order separate powerways.

Tip: Remember to order end-of-run trim and vertical corner trim packages.

Tip: Factory-installed wire separator is only an option on panels without power. A wire separator is included with the powerway in panels specified with power.

Standard Includes	Required to Specify
<ul style="list-style-type: none"> <li>Tackable acoustical panel with two fabric surfaces: horizontal fabric</li> <li>Base covers with receptacle knockouts and low top cap: paint price group 1</li> <li>Top cap aligner: black plastic</li> <li>Universal connector package</li> <li>Frame: fire retardant polyurethane foam</li> </ul>	<ol style="list-style-type: none"> <li>Style number</li> <li>Fabric color number for panel</li> <li>Paint color number for trim</li> <li>Options, if selected (see below)</li> </ol> <p>▶ See <i>Surface Materials</i>, page 506.</p>

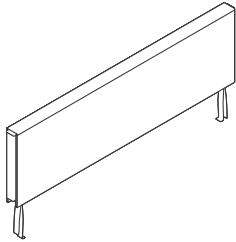
Options	U.S. Price	Required to Specify
<b>Surface Materials</b> <b>Trim</b> <ul style="list-style-type: none"> <li>Paint price group 1</li> <li>Paint price group 2</li> </ul>	No cost +\$ 14	Specify paint color number. Specify paint color number.
<b>Power Installation</b> <ul style="list-style-type: none"> <li>Factory installation</li> <li>Field installation</li> </ul>	No cost No cost	Specify <i>with factory installation</i> . Specify <i>with field installation</i> .
<b>Powerway</b> <ul style="list-style-type: none"> <li>No powerway</li> <li>Shared powerway</li> <li>4 circuit 3+D</li> <li>Separate neutral powerway</li> <li>4 circuit 2+2</li> <li>4 circuit 3I+1</li> </ul>	No cost +\$181 +\$213 +\$225 +\$267 +\$267	Specify <i>with no powerway</i> . Specify <i>with shared powerway</i> . Specify <i>with 4 circuit 3+D</i> . Specify <i>with separate neutral powerway</i> . Specify <i>with 4 circuit 2+2</i> . Specify <i>with 4 circuit 3I+1</i> .
<b>Top Cap</b> <ul style="list-style-type: none"> <li>Low top cap</li> <li>No top cap</li> </ul>	No cost No cost	Specify <i>with low top cap</i> . Specify <i>with no top cap</i> .

Specification Information							
Style Number	Dimensions Height	U.S. Base Prices					
		Width					
		24"W	30"W	36"W	42"W	48"W	60"W
AMQTSAPF	42"	\$519	\$539	\$591	\$654	\$696	\$799
	48"	\$539	\$590	\$631	\$716	\$768	\$846
	54"	\$543	\$603	\$641	\$733	\$782	\$852
	66"	\$554	\$631	\$671	\$756	\$833	\$945

TEKTIS

**For Canadian Pricing**  
 Multiply U.S. Price by the Canadian price factor.  
 ▶ See page 1 for details.

# Tackable Acoustical Stackers



*Tip: Remember to order end-of-run trim and vertical corner trim packages.*

*Tip: When adding a stacker to existing panels with a power or cable pole connected at L-, T-, or X- corner, the universal panel connector can not be used. Contact [orders@AMQsolutions.com](mailto:orders@AMQsolutions.com) to order service parts for special connections.*

Standard Includes	Required to Specify
<ul style="list-style-type: none"> <li>Tackable acoustical stacker: fabric</li> <li>Frame: fire retardant polyurethane foam</li> <li>Universal connector package</li> <li>Two stacking fork connectors</li> </ul>	<ul style="list-style-type: none"> <li>1 Style number</li> <li>2 Fabric color number for stacker</li> <li>3 Options, if selected (see below)</li> <li>▶ See <i>Surface Materials</i>, page 506.</li> </ul>

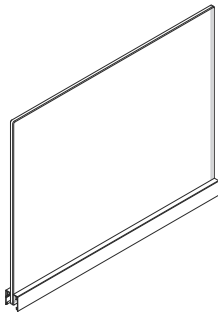
Options	U.S. Price	Required to Specify
<b>Fabric Direction</b> • Horizontal	No cost	Specify <i>with horizontal fabric direction</i> .

## Specification Information

Style Number	Dimensions Height	U.S. Base Prices						
		Width						
		24"W	30"W	36"W	42"W	48"W	60"W	72"W
<b>AMQTSAPS</b>	12"	\$398	\$413	\$448	\$501	\$532	\$608	\$618
	18"	\$458	\$488	\$537	\$598	\$631	\$725	\$732
	24"	\$478	\$513	\$566	\$627	\$660	\$756	\$767



**For Canadian Pricing**  
 Multiply U.S. Price by the Canadian price factor.  
 ▶ See page 1 for details.



Tip: Only one frameless glass stacker per panel is allowed.

Tip: Frameless glass stackers cannot stack on top of a tackable or framed glass stacker.

Tip: Stackers must be equal in width to the corresponding panels. Spanning stackers are not permitted for frameless glass.

Tip: Remember to order end-of-run trim and vertical corner trim packages.

Standard Includes	Required to Specify
<ul style="list-style-type: none"> <li>• Glass screen: 6500 Clear Glass</li> <li>• Two supports</li> <li>• Top cap trim: paint</li> </ul>	<ol style="list-style-type: none"> <li>1 Style number</li> <li>2 Glass finish for screen</li> <li>3 Paint color number for trim</li> <li>4 Options, if selected (see below)</li> </ol> <p>▶ See <i>Surface Materials</i>, page 506.</p>

Options	U.S. Price	Required to Specify
<b>Surface Materials</b> <b>Trim</b> <ul style="list-style-type: none"> <li>• Paint price group 1</li> <li>• Paint price group 2</li> </ul>	No cost +\$14	Specify paint color number. Specify paint color number.
<b>Glass screen</b> <ul style="list-style-type: none"> <li>• Clear glass</li> <li>• Frosted glass</li> </ul>	Prices below Prices below	Specify with <i>6500 Clear Glass</i> . Specify with <i>6530 Frosted Glass</i> .

Specification Information		U.S. Base Prices					
Style Number	Dimensions Height	Width					
		24"W	30"W	36"W	42"W	48"W	60"W

## Clear Glass Screen

TKFGS	Height	24"W	30"W	36"W	42"W	48"W	60"W
	6"	\$440	\$466	\$510	\$550	\$588	\$ 668
	12"	\$505	\$540	\$605	\$654	\$702	\$ 806
	18"	\$590	\$650	\$736	\$785	\$850	\$ 999

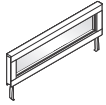
## Frosted Glass Screen

TKFGS	Height	24"W	30"W	36"W	42"W	48"W	60"W
	6"	\$483	\$516	\$580	\$625	\$670	\$ 785
	12"	\$558	\$595	\$680	\$734	\$792	\$ 941
	18"	\$650	\$720	\$821	\$875	\$960	\$1444



**For Canadian Pricing**  
 Multiply U.S. Price by the Canadian price factor.  
 ▶ See page 1 for details.

# Glass Panel Stackers



Tip: Only one glass stacker per panel is allowed.

Tip: Remember to order change-of-height connectors.

Tip: Remember to order end-of-run trim and vertical corner trim packages.

Standard Includes	Required to Specify
<ul style="list-style-type: none"> <li>• Glass stacker: 6500 Clear glass</li> <li>• Border: paint price group 1</li> <li>• Frame: fire retardant polyurethane foam</li> <li>• Universal connector package</li> <li>• Two stacking fork connectors</li> </ul>	<ul style="list-style-type: none"> <li>1 Style number</li> <li>2 Paint color number for border</li> <li>3 Options, if selected (see below)</li> <li>▶ See <i>Surface Materials</i>, page 506.</li> </ul>

Options	U.S. Price	Required to Specify
<b>Surface Materials</b> <ul style="list-style-type: none"> <li>• Trim</li> <li>• Paint price group 1</li> <li>• Paint price group 2</li> </ul>	No cost +\$14	Specify paint color number. Specify paint color number.

Specification Information								
Style Number	Dimensions Height	U.S. Base Prices						
		Width						
		24"W	30"W	36"W	42"W	48"W	60"W	72"W
AMQTSAPSG	12"	\$656	\$686	\$747	\$ 837	\$ 888	\$1014	\$1024
	18"	\$783	\$816	\$894	\$ 999	\$1055	\$1212	\$1226
	24"	\$823	\$854	\$937	\$1044	\$1104	\$1270	\$1284



**For Canadian Pricing**  
Multiply U.S. Price by the Canadian price factor.  
▶ See page 1 for details.



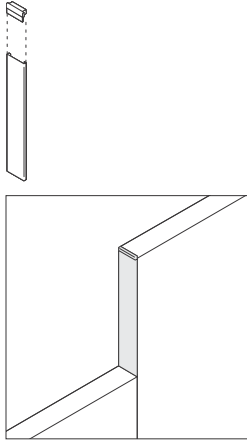
Standard Includes	Required to Specify
<ul style="list-style-type: none"> <li>• End-of-run trim: paint price group 1</li> <li>• One low end cap: plastic to match paint</li> </ul>	<ul style="list-style-type: none"> <li>1 Style number</li> <li>2 Paint color number for trim</li> <li>3 Options, if selected (see below)</li> <li>▶ See <i>Surface Materials</i>, page 506.</li> </ul>

Options	U.S. Price	Required to Specify
<b>Surface Materials</b> <ul style="list-style-type: none"> <li>• <b>Trim</b></li> <li>• Paint price group 1</li> <li>• Paint price group 2</li> </ul>	<ul style="list-style-type: none"> <li>No cost</li> <li>+\$14</li> </ul>	<ul style="list-style-type: none"> <li>Specify paint color number.</li> <li>Specify paint color number.</li> </ul>
<b>End Cap</b> <ul style="list-style-type: none"> <li>• Low end cap</li> <li>• Stacker end cap</li> </ul>	<ul style="list-style-type: none"> <li>No cost</li> <li>No cost</li> </ul>	<ul style="list-style-type: none"> <li>Specify <i>with low end cap</i>.</li> <li>Specify <i>with stacker end cap</i>.</li> </ul>

Specification Information		
Style Number	Corresponding Panel Height	U.S. Base Price
<b>AMQTSAPTE</b>	42"	\$73
	48"	\$73
	54"	\$73
	60"	\$73
	66"	\$73
	72"	\$73
	78"	\$73

 **For Canadian Pricing**  
 Multiply U.S. Price by the Canadian price factor.  
 ▶ See page 1 for details.

# Vertical In-Line Change-of-Height Trim



Tip: Remember to order change-of-height connectors.

Standard Includes	Required to Specify
<ul style="list-style-type: none"> <li>Change-of-height trim: paint price group 1</li> <li>One plastic low end cap to match paint</li> </ul>	<ol style="list-style-type: none"> <li>Style number</li> <li>Paint color number for trim</li> <li>Options, if selected (see below)</li> </ol> <p>► See <i>Surface Materials</i>, page 506.</p>

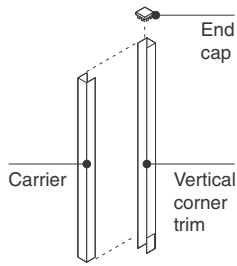
Options	U.S. Price	Required to Specify
<b>Surface Materials</b> <b>Trim</b> <ul style="list-style-type: none"> <li>Paint price group 1</li> <li>Paint price group 2</li> </ul>	No cost +\$14	Specify paint color number. Specify paint color number.
<b>End Cap</b> <ul style="list-style-type: none"> <li>Low end cap</li> <li>Stacker end cap</li> </ul>	No cost No cost	Specify <i>with low end cap</i> . Specify <i>with stacker end cap</i> .

## Specification Information

Style Number	Panel Height	U.S. Base Price
<b>AMQTSAPTXS</b>	4"	\$73
	6"	\$73
	10"	\$73
	12"	\$73
	13½"	\$73
	16"	\$73
	18"	\$73
	19½"	\$73
	22"	\$73
	24"	\$73
	25½"	\$73
	31½"	\$73
	36"	\$73
	37½"	\$73



**For Canadian Pricing**  
 Multiply U.S. Price by the Canadian price factor.  
 ► See page 1 for details.



Standard Includes	Required to Specify
-------------------	---------------------

- Vertical corner trim: paint price group 1
- One low end cap: plastic to match paint
- Carrier: fire retardant polyurethane foam

- 1 Style number
  - 2 Paint color number for trim
  - 3 Options, if selected (see below)
- ▶ See *Surface Materials*, page 506.

Options	U.S. Price	Required to Specify
---------	------------	---------------------

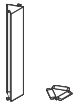
<b>Surface Materials</b>	<ul style="list-style-type: none"> <li>• Trim</li> <li>• Paint price group 1</li> <li>• Paint price group 2</li> </ul>	No cost +\$14	Specify paint color number. Specify paint color number.
<b>End Cap</b>	<ul style="list-style-type: none"> <li>• Low end cap</li> <li>• Stacker end cap</li> </ul>	No cost No cost	Specify <i>with low end cap</i> . Specify <i>with stacker end cap</i> .

Specification Information			
Style Number	Trim Height	Carrier Height	U.S. Base Price

AMQTSAPTC	42"	42"	\$104
	48"	48"	\$104
	54"	54"	\$104
	66"	66"	\$104

 **For Canadian Pricing**  
 Multiply U.S. Price by the Canadian price factor.  
 ▶ See page 1 for details.

# 120° Vertical Corner Trims



Standard Includes	Required to Specify
<ul style="list-style-type: none"> <li>• Corner trim: paint price group 1</li> <li>• Low trim end caps for two- or three-way connections (one each): plastic to match paint</li> </ul>	<ul style="list-style-type: none"> <li>1 Style number</li> <li>2 Paint color number for trim</li> <li>3 Options, if selected (see below)</li> <li>▶ See <i>Surface Materials</i>, page 506.</li> </ul>

Surface Materials	Options	U.S. Price	Required to Specify
	<b>Trim</b> <ul style="list-style-type: none"> <li>• Paint price group 1</li> <li>• Paint price group 2</li> </ul>	No cost +\$14	Specify paint color number. Specify paint color number.

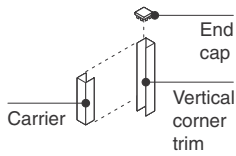
Specification Information		
Style Number	Trim Height	U.S. Base Price
<b>AMQTSAPTCY</b>	42"	\$137
	48"	\$137
	54"	\$137
	66"	\$137



**For Canadian Pricing**  
 Multiply U.S. Price by the Canadian price factor.  
 ▶ See page 1 for details.

# Vertical Corner Change-of-Height Trims

Vertical Corner  
Change-of-Height  
Trims



Tip: Vertical corner change-of-height trims can be used with panel stackers.

Standard Includes	Required to Specify
<ul style="list-style-type: none"> <li>Vertical corner trim: paint price group 1</li> <li>One low end cap: plastic to match paint</li> <li>Carrier: fire retardant polyurethane foam</li> </ul>	<ol style="list-style-type: none"> <li>Style number</li> <li>Paint color number for trim</li> <li>Options, if selected (see below)</li> </ol> <p>▶ See <i>Surface Materials</i>, page 506.</p>

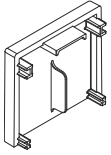
Options	U.S. Price	Required to Specify
<b>Surface Materials</b> <ul style="list-style-type: none"> <li>Trim</li> <li>Paint price group 1</li> <li>Paint price group 2</li> </ul>	No cost +\$14	Specify paint color number. Specify paint color number.
<b>End Cap</b> <ul style="list-style-type: none"> <li>Low end cap</li> <li>Stacker end cap</li> </ul>	No cost No cost	Specify <i>with low end cap</i> . Specify <i>with stacker end cap</i> .

Specification Information		
Style Number	Trim Height	U.S. Base Price
AMQTSAPTXC	6"	\$73
	12"	\$73
	18"	\$73
	24"	\$73

TEKTIS

 **For Canadian Pricing**  
Multiply U.S. Price by the Canadian price factor.  
▶ See page 1 for details.

# Vertical End-of-Run Stacker End Cap



Standard Includes	Required to Specify
<ul style="list-style-type: none"> <li>End cap: paint price group 1</li> </ul>	<ol style="list-style-type: none"> <li>Style number</li> <li>Paint color for end cap</li> <li>Options, if selected (see below)</li> </ol> <p>▶ See <i>Surface Materials</i>, page 506.</p>

Options	U.S. Price	Required to Specify
<b>Surface Materials</b> <ul style="list-style-type: none"> <li>Paint price group 1</li> <li>Paint price group 2</li> </ul>	No cost +\$14	Specify paint color number. Specify paint color number.

## Specification Information

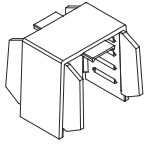
Style Number	U.S. Base Price
AMQTKBSTE	\$73



**For Canadian Pricing**  
 Multiply U.S. Price by the Canadian price factor.  
 ▶ See page 1 for details.

# Middle-of-Run Boundary Screen Top Cap

Middle-of-Run Boundary  
Screen Top Cap



Standard Includes	Required to Specify
-------------------	---------------------

- Top cap: paint price group 1

- 1 Style number
  - 2 Paint color for end cap
  - 3 Options, if selected (see below)
- ▶ See *Surface Materials*, page 506.

	Options	U.S. Price	Required to Specify
--	---------	------------	---------------------

**Surface Materials**

- Paint price group 1
- Paint price group 2

No cost  
+\$14

Specify paint color number.  
Specify paint color number.

Specification Information	
---------------------------	--

• **Style Number**

• **U.S. Base Price**

AMQTKBSTMC

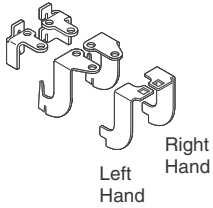
\$21

TEKTIS

 **For Canadian Pricing**  
Multiply U.S. Price by the Canadian price factor.  
▶ See page 1 for details.

# Panel Connectors

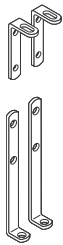
## Change-of-Height In-Line and Corner Panel Connector Package



*Tip: Change-of-height connections must be used at top of base panel and each stacker whenever possible to increase stability.*

Standard Includes		Required to Specify
<ul style="list-style-type: none"> <li>Two corner and two in-line connectors: paint</li> </ul>		1 Style number 2 Paint color number for connector ▶ See <i>Surface Materials</i> , page 506.
Specification Information		
Style Number	U.S. Price	
AMQTSAPBCOH	\$43	

## Wall Start Connector Package



Standard Includes		Required to Specify
<ul style="list-style-type: none"> <li>Wall start connector package: black paint</li> </ul>		Style number
Specification Information		
Style Number	U.S. Price	
AMQTSAPBWS66	\$43	

## 120° Connectors



*Tip: Two-way, 120° connection requires one package. Three-way, 120° connection requires three packages.*

*Tip: 120° connector does not allow change-of-height connections.*

Standard Includes		Required to Specify
<ul style="list-style-type: none"> <li>120° connectors: fire retardant polyurethane foam</li> <li>Package includes two 120° connectors and eight screws</li> </ul>		Style number
Specification Information		
Style Number	U.S. Price	
AMQTSAPB120	\$43	



**For Canadian Pricing**  
 Multiply U.S. Price by the Canadian price factor.  
 ▶ See page 1 for details.



# Worksurface Legs and Supports

Standard Includes	Required to Specify
<ul style="list-style-type: none"> <li>• Post leg, H-leg, end panel, and cantilever: paint price group 1</li> <li>• Worksurface supports and channels: black paint</li> <li>• 2 3/4" adjustable glides on legs</li> <li>• Attachment hardware</li> </ul>	<ol style="list-style-type: none"> <li>1 Style number</li> <li>2 Paint color number for leg, end panel, and cantilever</li> <li>3 Options, if selected (see below)                     <ul style="list-style-type: none"> <li>▶ See <i>Surface Materials</i>, page 506.</li> </ul> </li> </ol>

Surface Materials	Options	U.S. Price	Required to Specify
	<b>End panel</b> <ul style="list-style-type: none"> <li>• Paint price group 1</li> <li>• Paint price group 2</li> </ul>	No cost +\$39	Specify paint color number. Specify paint color number.
	<b>Leg</b> <ul style="list-style-type: none"> <li>• Paint price group 1</li> <li>• Paint price group 2</li> </ul>	No cost +\$17	Specify paint color number. Specify paint color number.

Specification Information			
Style Number	Dimensions		U.S. Base Price
	D	H	

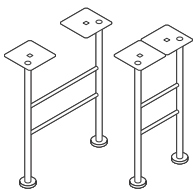
## Post Leg

<b>AMQTSATP27</b>	N.A.	27"	\$169
-------------------	------	-----	-------



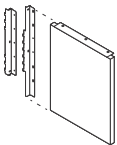
## H-Leg

<b>AMQTSATH</b>	11"	N.A.	\$229
	20"	N.A.	\$282



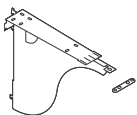
## On-Module End Panel

<b>AMQTSATEP</b>	24"	27"	\$513
	30"	27"	\$586



## Cantilever with Tie Plate

<b>AMQTSATCANT</b>	16"	13"	\$123
--------------------	-----	-----	-------



▶ **Specification Information, continued on next page**



### For Canadian Pricing

Multiply U.S. Price by the Canadian price factor.

▶ See page 1 for details.

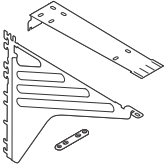
► Specification Information, continued from previous page

**Specification Information**

Style Number	Dimensions D H	U.S. Base Price
--------------	-------------------	-----------------

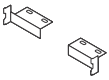
**Universal Cantilever with Tie Plate**

<b>AMQUCANT</b>	15½" 12¼"	\$141
-----------------	-----------	-------



**Side Support Bracket to Connect Worksurface to Panel**

<b>AMQTSATSIDE</b>	N.A.	N.A.	\$ 51
--------------------	------	------	-------



**For Canadian Pricing**  
 Multiply U.S. Price by the Canadian price factor.  
 ► See page 1 for details.

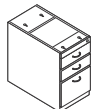
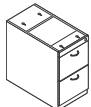
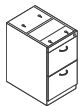
# Fixed Pedestals

*Tip: Tektis fixed pedestals should be used under a worksurface and should not be used as a stand alone pedestal.*

*Tip: File drawer rails are required to file legal-sized files or side-to-side letter-sized files in pedestal.*

*Tip: When using a Tektis pedestal with a single pedestal desk, desks below 48"W require an interlock and a counterweight. Single pedestal desks with 28"D pedestals also require an interlock (**AMQTS2INT**) and counterweight (**AMQTS2CW**).*

*Tip: If the master key plug is optioned, **AMQLOCK9201XF** must be specified separately to be included.*



Standard Includes	Required to Specify
<ul style="list-style-type: none"> <li>• Pedestal: paint price group 1</li> <li>• Ledge pull: paint to match</li> <li>• Lock face ring with plastic plug to accommodate lock cylinder, if keyed lock selected: 0835 Black</li> <li>• Attachment hardware</li> <li>• Lock cylinder included in package, field-installed</li> <li>• Steel ball-bearing suspensions on box and file drawers</li> <li>• Adjustable glides: black</li> </ul>	<ol style="list-style-type: none"> <li>1 Style number</li> <li>2 Paint color number for pedestal</li> <li>3 Paint color number for pull</li> <li>4 Options, if selected (see below)</li> </ol> <p>▶ See <i>Surface Materials</i>, page 506.</p>

Options	U.S. Price	Required to Specify
<b>Surface Materials</b> <ul style="list-style-type: none"> <li>• <b>Case</b></li> <li>• Paint price group 1</li> <li>• Paint price group 2</li> <li>• <b>Pull</b></li> <li>• Paint price group 1</li> <li>• Paint price group 2</li> </ul>	No cost +\$11  No cost +\$ 6	Specify paint color number. Specify paint color number.  Specify paint color number. Specify paint color number.
<b>Pencil Tray</b> <ul style="list-style-type: none"> <li>• With pencil tray</li> </ul>	+\$22	Specify <i>with pencil tray</i> .
<b>Drawer Rail</b> <ul style="list-style-type: none"> <li>• With drawer rail</li> </ul>	+\$22	Specify <i>with drawer rail</i> .
<b>Keys</b> <ul style="list-style-type: none"> <li>• Standard key plug</li> <li>• Master key plug</li> </ul>	No cost +\$39	Specify <i>with standard key plug</i> . Specify <i>with master key plug</i> .

Specification Information				
• Style Number	• Dimensions			• U.S. Base Price
	D	W	H	

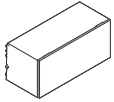
File, File				
<b>AMQTS2PFFU</b>	22"	15"	27"	\$564

Box, Box, File				
<b>AMQTS2PBBFU</b>	22"	15"	27"	\$595

File, File				
<b>AMQTS2PFFU</b>	28"	15"	27"	\$613

Box, Box, File				
<b>AMQTS2PBBFU</b>	28"	15"	27"	\$647

 **For Canadian Pricing**  
 Multiply U.S. Price by the Canadian price factor.  
 ▶ See page 1 for details.



Tip: TEKTIS bins cannot be upmounted.

Standard Includes	Required to Specify
<ul style="list-style-type: none"> <li>Overhead bin with lift-up door: paint price group 1</li> <li>Shelf backstop</li> <li>On-module attachment hooks with safety catch</li> <li>Lock face ring with plastic plug to accommodate lock cylinder, if keyed lock selected: 0835 Black</li> <li>Lock cylinder included in package, field-installed</li> </ul>	<ul style="list-style-type: none"> <li>1 Style number</li> <li>2 Paint color number for bin</li> <li>3 Options, if selected (see below)</li> <li>▶ See <i>Surface Materials</i>, page 506.</li> </ul>

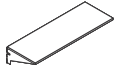
Options	U.S. Price	Required to Specify
<b>Surface Materials</b> <b>Trim</b> <ul style="list-style-type: none"> <li>Paint price group 1</li> <li>Paint price group 2</li> </ul>	<ul style="list-style-type: none"> <li>No cost</li> <li>+\$11</li> </ul>	<ul style="list-style-type: none"> <li>Specify paint color number.</li> <li>Specify paint color number.</li> </ul>
<b>Keys</b> <ul style="list-style-type: none"> <li>Standard key plug</li> <li>Master key plug</li> </ul>	<ul style="list-style-type: none"> <li>No cost</li> <li>+\$39</li> </ul>	<ul style="list-style-type: none"> <li>Specify <i>with standard key plug</i>.</li> <li>Specify <i>with master key plug</i>.</li> </ul>

Specification Information					
Style Number	Dimensions			Number of Doors	U.S. Base Price
	D	W	H		
AMQTSASUBL	15 3/4"	24"	16 1/4"	1	\$ 603
	15 3/4"	30"	16 1/4"	1	\$ 630
	15 3/4"	36"	16 1/4"	1	\$ 656
	15 3/4"	42"	16 1/4"	1	\$ 683
	15 3/4"	48"	16 1/4"	1	\$ 718
	15 3/4"	60"	16 1/4"	2	\$1110
	15 3/4"	72"	16 1/4"	2	\$1222



**For Canadian Pricing**  
 Multiply U.S. Price by the Canadian price factor.  
 ▶ See page 1 for details.

# Laminate Common Shelves



Tip: For anticipated heavy loads on 42"W and 48"W laminate common shelves, a 39"W field-installed reinforcing channel (**AMQTSATRC**) can be used.

Standard Includes	Required to Specify
<ul style="list-style-type: none"> <li>1 3/16"-thick shelf: Low-Pressure Laminate</li> <li>3 mm radius profile edge: plastic</li> <li>Support brackets: paint price group 1</li> </ul>	<ol style="list-style-type: none"> <li>Style number</li> <li>Laminate color number for shelf</li> <li>Plastic color number for edge</li> <li>Paint color number for brackets</li> <li>Options, if selected (see below)</li> </ol> <p>▶ See <i>Surface Materials</i>, page 506.</p>

Options	U.S. Price	Required to Specify
<b>Surface Materials</b> <b>Trim</b> <ul style="list-style-type: none"> <li>Paint price group 1</li> <li>Paint price group 2</li> </ul>	No cost +\$11	Specify paint color number. Specify paint color number.

Specification Information				
Style Number	Dimensions			U.S. Base Price
	D	W	H	
AMQTSASLCL	15"	24"	7 3/4"	\$164
	15"	30"	7 3/4"	\$169
	15"	36"	7 3/4"	\$179
	15"	42"	7 3/4"	\$192
	15"	48"	7 3/4"	\$209



**For Canadian Pricing**  
 Multiply U.S. Price by the Canadian price factor.  
 ▶ See page 1 for details.

# Wall Channels for Overhead Bins and Shelves

Wall Channels for Overhead  
Bins and Shelves

Standard Includes	Required to Specify
<ul style="list-style-type: none"> <li>• Pair of channels: paint</li> </ul>	<ul style="list-style-type: none"> <li>1 Style number</li> <li>2 Paint color number for channels</li> <li>▶ See <i>Surface Materials</i>, page 506.</li> </ul>

Specification Information	
• Style Number	• U.S. Price
AMQTS7BSWHC	\$159

TEKTIS



**For Canadian Pricing**  
Multiply U.S. Price by the  
Canadian price factor.  
▶ See page 1 for details.

# Wall Channel Horizontal Brace



Standard Includes	Required to Specify
-------------------	---------------------

- Brace: paint

- 1 Style number
- 2 Paint color number for brace

Specification Information		
Style Number	Width	U.S. Price

Style Number	Width	U.S. Price
<b>AMQTSHB</b>	42"	\$116
	48"	\$116
	60"	\$116
	72"	\$116



**For Canadian Pricing**  
 Multiply U.S. Price by the  
 Canadian price factor.  
 ▶ See page 1 for details.



Tip: You must specify receptacle to match wiring schematic used in other components.

Standard Includes	Required to Specify
-------------------	---------------------

- |   |  |
|---|--|
| <ul style="list-style-type: none"> <li>Package of six powerway receptacles: 6000 Black</li> </ul> | 1 Style number<br>2 Options, if selected (see below) |
|---|--|

Options	U.S. Price	Required to Specify
---------	------------	---------------------

- |  |                           |  |
|--|---------------------------|--|
| <b>Controlled Stamp</b> <ul style="list-style-type: none"> <li>No stamp</li> <li>3-circuit with controlled stamp</li> <li>4-circuit with controlled stamp</li> </ul> | No cost<br>+\$25<br>+\$26 | Specify <i>with no stamp</i> .<br>Specify with controlled stamp.<br>Specify with controlled stamp. |
|--|---------------------------|--|

Specification Information			
Style Number	Description	Size	U.S. Base Price

### 3-Circuit with Shared Neutral

<b>AMQ TSAESB</b>	Line 1	Standard	\$302
	Line 2	Standard	\$302
	Line 3	Standard	\$302

### 3-Circuit with Separate Neutral

<b>AMQ TSAESB</b>	Line A	Standard	\$450
	Line B	Standard	\$450
	Line C	Large	\$587

### 4-Circuit 3+D

<b>AMQ TSAEDASB</b>	Line 1	Standard	\$302
	Line 2	Standard	\$302
	Line 3	Standard	\$302
	Line 4	Large	\$392

### 4-Circuit with 2+2 Wiring

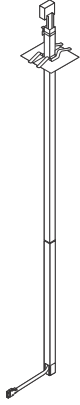
<b>AMQ TSAEDASB</b>	Line 1	Standard	\$335
	Line 2	Standard	\$335
	Line 3	Standard	\$451
	Line 4	Large	\$451

### 4-Circuit with 3I+1 Wiring

<b>AMQ TSAEDASB</b>	Line 1	Standard	\$451
	Line 2	Standard	\$451
	Line 3	Standard	\$451
	Line 4	Large	\$587

**For Canadian Pricing**  
 Multiply U.S. Price by the Canadian price factor.  
 ▶ See page 1 for details.

# Power Pole



Standard Includes	Required to Specify
<ul style="list-style-type: none"> <li>• Power pole: paint price group 1</li> <li>• Ceiling trim plate: 4790 Sodium paint only</li> <li>• Harness with 3-circuit, and shared neutral</li> <li>• Junction box</li> <li>• Mounting brackets</li> <li>• Pair of corner change-of-height connectors</li> </ul>	<ul style="list-style-type: none"> <li>1 Style number</li> <li>2 Paint color number for pole</li> <li>3 Options, if selected (see below)</li> <li>▶ See <i>Surface Materials</i>, page 506.</li> </ul>

Options	U.S. Price	Required to Specify
<b>Surface Materials</b> <b>Pole</b> <ul style="list-style-type: none"> <li>• Paint price group 1</li> <li>• Paint price group 2</li> </ul>	No cost +\$14	Specify paint color number. Specify paint color number.
<b>Harness</b> <ul style="list-style-type: none"> <li>• Shared harness</li> <li>• Separate neutral harness</li> </ul>	No cost +\$17	Specify <i>with shared harness</i> . Specify <i>with separate neutral harness</i> .
<b>Wiring Schematic</b> <ul style="list-style-type: none"> <li>• 4 circuit 3+D</li> <li>• 4 circuit 2+2</li> <li>• 4 circuit 3I+1</li> </ul>	No cost +\$17 +\$17	Specify <i>with 4 circuit 3+D</i> . Specify <i>with 4 circuit 2+2</i> . Specify <i>with 4 circuit 3I+1</i> .

Specification Information		
Style Number	Panel Height	U.S. Base Price

## 3-Circuit

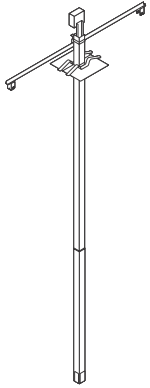
AMQ TSAEP3B	Panel Height	U.S. Base Price
	42"	\$636
	48"	\$636
	54"	\$636
	66"	\$636

## 4-Circuit

AMQ TSAEP4B	Panel Height	U.S. Base Price
	42"	\$722
	48"	\$722
	54"	\$722
	66"	\$722



**For Canadian Pricing**  
 Multiply U.S. Price by the Canadian price factor.  
 ▶ See page 1 for details.



Standard Includes	Required to Specify
<ul style="list-style-type: none"> <li>• Cable pole: paint price group 1</li> <li>• Ceiling trim plate: 4790 Sodium paint only</li> <li>• Junction box</li> <li>• Mounting brackets</li> <li>• Pair of corner change-of-height connectors</li> </ul>	<ul style="list-style-type: none"> <li>1 Style number</li> <li>2 Paint color number for pole</li> <li>3 Options, if selected (see below)</li> <li>▶ See <i>Surface Materials</i>, page 506.</li> </ul>

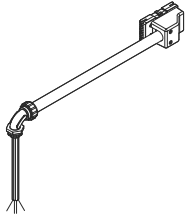
Options	U.S. Price	Required to Specify
<b>Surface Materials</b> <b>Pole</b> <ul style="list-style-type: none"> <li>• Paint price group 1</li> <li>• Paint price group 2</li> </ul>	No cost +\$14	Specify paint color number. Specify paint color number.

Specification Information		
Style Number	Panel Height	U.S. Base Price
AMQ TSAEPC	42"	\$579
	48"	\$579
	54"	\$579
	66"	\$579

TEKTIS

 **For Canadian Pricing**  
 Multiply U.S. Price by the Canadian price factor.  
 ▶ See page 1 for details.

# Wiring Schematic



Standard Includes	Required to Specify
-------------------	---------------------

- |  |  |
|--|--|
| <ul style="list-style-type: none"> <li>• Power infeed cover: black plastic only</li> <li>• 6' long, 1/2" diameter conduit: black plastic only</li> <li>• 3-circuit with shared neutral or 4-circuit 3+D</li> </ul> | <ul style="list-style-type: none"> <li>1 Style number</li> <li>2 Options, if selected (see below)</li> </ul> |
|--|--|

Wiring Option	Options	U.S. Price	Required to Specify
---------------	---------	------------	---------------------

- |  |   |   |  |
|--|---|---|--|
|  | <ul style="list-style-type: none"> <li>• 4 circuit 3+D</li> <li>• Shared powerway wiring</li> <li>• Seperate neutral wiring</li> <li>• 4 circuit 2+2</li> <li>• 4 circuit 3I+1</li> </ul> | <ul style="list-style-type: none"> <li>No cost</li> <li>No cost</li> <li>+\$53</li> <li>+\$64</li> <li>+\$64</li> </ul> | <ul style="list-style-type: none"> <li>Specify <i>with 4 circuit 3+D.</i></li> <li>Specify <i>with shared powerway wiring.</i></li> <li>Specify <i>with seperate neutral wiring.</i></li> <li>Specify <i>with 4 circuit 2+2.</i></li> <li>Specify <i>with 4 circuit 3I+1.</i></li> </ul> |
|--|---|---|--|

Specification Information			
---------------------------	--	--	--

Style Number	U.S. Base Price	Style Number	U.S. Base Price
<b>3-Circuit Shared Neutral</b>		<b>4-Circuit 3+D</b>	
AMQTSAE98669B	\$366	AMQTSAE986694B	\$401
<b>For Use In San Francisco</b>		<b>For Use In San Francisco</b>	
AMQTSAE98669SFB	\$366	AMQTSAE986694SFB	\$401



**For Canadian Pricing**  
 Multiply U.S. Price by the Canadian price factor.  
 ▶ See page 1 for details.



*Tip: Grommet requires a 3" diameter hole in the worksurface.*

Standard Includes	Required to Specify
<ul style="list-style-type: none"> <li>Package of 10 grommets: black plastic</li> </ul>	Style number

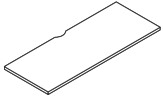
Specification Information	
Style Number	U.S. Price
<b>AMQ TSAEGROM</b>	\$74



 **For Canadian Pricing**  
 Multiply U.S. Price by the Canadian price factor.  
 ▶ See page 1 for details.

# Straight Worksurfaces

with 1/2" Cord Drop



Standard Includes	Required to Specify
<ul style="list-style-type: none"> <li>• 1 3/16"-thick worksurface: Low-Pressure Laminate</li> <li>• 3 mm radius profile edge on user's side: plastic</li> <li>• Side and back edges: plastic default to match user's side</li> <li>• 1/2" cord drop along the back edge for cable management</li> </ul>	<ol style="list-style-type: none"> <li>1 Style number</li> <li>2 Low-Pressure Laminate color number for worksurface</li> <li>3 Plastic color number for edge</li> <li>4 Options, if selected (see below)</li> </ol> <p>▶ See <i>Surface Materials</i>, page 506.</p>

Options	U.S. Price	Required to Specify
<b>Scallop</b> <ul style="list-style-type: none"> <li>• No scallop</li> <li>• With scallop</li> </ul>	No cost No cost	Specify <i>with no scallop</i> . Specify <i>with scallop</i> .

Specification Information										
Style Number	Dimensions Depth	U.S. Prices								
		Width								
		24"W	30"W	36"W	42"W	48"W	54"W	60"W	66"W	72"W
<b>AMQCDWS</b>	23 1/2"	\$188	\$197	\$214	\$244	\$280	\$319	\$349	\$382	\$392
	29 1/2"	\$208	\$230	\$253	\$284	\$312	\$358	\$401	\$434	\$471



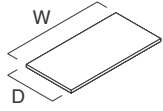
**For Canadian Pricing**

Multiply U.S. Price by the Canadian price factor.

▶ See page 1 for details.

# Straight Worksurfaces

with Full Depth



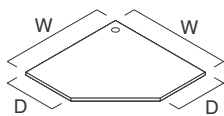
Standard Includes	Required to Specify
<ul style="list-style-type: none"> <li>• 1<math>\frac{3}{16}</math>"-thick worksurface: Low-Pressure Laminate</li> <li>• 3 mm radius profile edge on user's side: plastic</li> <li>• Side and back edges: plastic default to match user's side</li> </ul>	<ol style="list-style-type: none"> <li>1 Style number</li> <li>2 Low-Pressure Laminate color number for worksurface</li> <li>3 Plastic color number for edge</li> </ol> <p>▶ See <i>Surface Materials</i>, page 506.</p>

Specification Information		U.S. Prices								
Style Number	Dimensions Depth	Width								
		24"W	30"W	36"W	42"W	48"W	54"W	60"W	66"W	72"W
<b>AMQTSAWLR</b>	24"	\$188	\$197	\$214	\$244	\$280	\$319	\$349	\$382	\$392
	30"	\$208	\$230	\$253	\$284	\$312	\$358	\$401	\$434	\$472



 **For Canadian Pricing**  
 Multiply U.S. Price by the Canadian price factor.  
 ▶ See page 1 for details.

# Straight Corner Worksurfaces



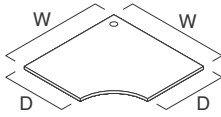
Standard Includes	Required to Specify
<ul style="list-style-type: none"> <li>• 1<sup>3</sup>/<sub>16</sub>"-thick worksurface: Low-Pressure Laminate</li> <li>• 3 mm radius profile edge on user's side: plastic</li> <li>• Side and back edges: plastic default to match user's side</li> <li>• Grommet: black plastic only</li> <li>• Corner bracket: black paint only</li> </ul>	<ol style="list-style-type: none"> <li>1 Style number</li> <li>2 Low-Pressure Laminate color number for worksurface</li> <li>3 Plastic color number for edge</li> </ol> <p>▶ See <i>Surface Materials</i>, page 506.</p>

## Specification Information

• Style Number	• Dimensions Depth	• U.S. Prices		
		Width		
		36"W	42"W	48"W
<b>AMQTSAWLCF</b>	24"	\$398	\$458	\$495
	30"	N.A.	N.A.	\$533

**For Canadian Pricing**  
 Multiply U.S. Price by the Canadian price factor.  
 ▶ See page 1 for details.

# Curved Corner Worksurfaces



Standard Includes	Required to Specify
<ul style="list-style-type: none"> <li>• 1<math>\frac{3}{16}</math>"-thick worksurface: Low-Pressure Laminate</li> <li>• 3 mm radius profile edge on user's side: plastic</li> <li>• Side and back edges: plastic default to match user's side</li> <li>• Grommet: black plastic only</li> <li>• Corner bracket: black paint only</li> </ul>	<ol style="list-style-type: none"> <li>1 Style number</li> <li>2 Low-Pressure Laminate color number for worksurface</li> <li>3 Plastic color number for edge</li> </ol> <p>▶ See <i>Surface Materials</i>, page 506.</p>

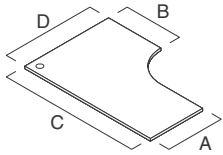
## Specification Information

• Style • Number	• Dimensions • Depth	• U.S. Prices		
		• Width		
		• 36"W	• 42"W	• 48"W
<b>AMQTSAWLCC</b>	24"	\$437	\$483	\$533
	30"	N.A.	N.A.	\$616



 **For Canadian Pricing**  
Multiply U.S. Price by the  
Canadian price factor.  
▶ See page 1 for details.

# Left-Hand Extended Curved Corner Worksurfaces



Tip: Long work surface spans require additional support.

## Standard Includes

- 1 3/16"-thick work surface: Low-Pressure Laminate
- 3 mm radius profile edge on user's side: plastic
- Side and back edges: plastic default to match user's side
- Grommet: black plastic only
- Corner bracket: black paint only

## Required to Specify

- 1 Style number
  - 2 Low-Pressure Laminate color number for work surface
  - 3 Plastic color number for edge
- ▶ See *Surface Materials*, page 506.

## Specification Information

• Style Number	• Dimensions				• U.S. Price
	A	B	C	D	
AMQTSAWLEL	24"	24"	60"	48"	\$721
	24"	24"	72"	48"	\$859
	30"	30"	60"	48"	\$763
	30"	30"	72"	48"	\$909



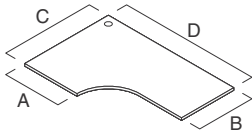
### For Canadian Pricing

Multiply U.S. Price by the Canadian price factor.

▶ See page 1 for details.

# Right-Hand Extended Curved Corner Worksurfaces

Right-Hand Extended  
Curved Corner  
Worksurfaces



*Tip: Long work surface spans require additional support.*

## Standard Includes

- 1 3/16"-thick work surface: Low-Pressure Laminate
- 3 mm radius profile edge on user's side: plastic
- Side and back edges: plastic default to match user's side
- Grommet: black plastic only
- Corner bracket: black paint only

## Required to Specify

- 1 Style number
  - 2 Low-Pressure Laminate color number for work surface
  - 3 Plastic color number for edge
- ▶ See *Surface Materials*, page 506.

## Specification Information

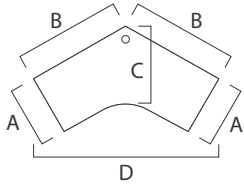
•Style Number	•Dimensions				•U.S. Price
	A	B	C	D	
AMQTSAWLER	24"	24"	48"	60"	\$721
	24"	24"	48"	72"	\$859
	30"	30"	48"	60"	\$763
	30"	30"	48"	72"	\$909

TEKTIS



**For Canadian Pricing**  
Multiply U.S. Price by the  
Canadian price factor.  
▶ See page 1 for details.

# 120° Corner Worksurfaces



## Standard Includes

- 1 3/16"-thick worksurface: Low-Pressure Laminate
- 3 mm radius profile edge on user's side: plastic
- Side and back edges: plastic default to match user's side
- Grommet: black plastic only
- Corner bracket: black paint only

## Required to Specify

- 1 Style number
  - 2 Low-Pressure Laminate color number for worksurface
  - 3 Plastic color number for edge
- ▶ See *Surface Materials*, page 506.

## Specification Information

• Style Number	• Dimensions				• U.S. Price
	A	B	C	D	
AMQTSAWLY	24"	36"	30 1/2"	63 11/32"	\$742
	24"	42"	30 1/2"	72 3/4"	\$795
	24"	48"	30 1/2"	85 5/32"	\$877



### For Canadian Pricing

Multiply U.S. Price by the Canadian price factor.

▶ See page 1 for details.



Tip: Transaction worksurfaces are for use on panels with a low top cap only.

Standard Includes	Required to Specify
<ul style="list-style-type: none"> <li>• 1<math>\frac{3}{16}</math>"-thick worksurface: Low-Pressure Laminate</li> <li>• 3 mm radius profile edge on user's side: plastic</li> <li>• Side and back edges: plastic default to match user's side</li> <li>• Grommet: black plastic only</li> <li>• Corner bracket: black paint only</li> </ul>	<ul style="list-style-type: none"> <li>1 Style number</li> <li>2 Low-Pressure Laminate color number for worksurface</li> <li>3 Plastic color number for edge</li> <li>▶ See <i>Surface Materials</i>, page 506.</li> </ul>

Specification Information			
Style Number	Dimensions		U.S. Price
	D	W	
AMQTSAWLT	16"	36"	\$282
	16"	42"	\$321
	16"	48"	\$338
	16"	60"	\$371



 **For Canadian Pricing**  
 Multiply U.S. Price by the Canadian price factor.  
 ▶ See page 1 for details.

# Fixed Pedestal Accessories

## Pedestal Filler

For Use with Under-Worksurface Pedestal to Attach to TEKTIS Panel System



*Tip: When using a pedestal to anchor the end of a panel run, you must use a pedestal filler.*

Standard Includes	Required to Specify
<ul style="list-style-type: none"> <li>• Filler: paint</li> <li>• Attachment hardware</li> </ul>	1 Style number 2 Paint color number for filler ▶ See <i>Surface Materials</i> , page 506.

Specification Information				
• Style Number	• Dimensions			• U.S. Price
	• D	• W	• H	
AMQTS2FILLER	23/16"	1"	27"	\$73

## Counterweight Package

For Use with Tektis Fixed Pedestals



*When using a Tektis pedestal with a single pedestal desk, desks below 48"W require an interlock and a counterweight. Single pedestal desks with 28"D pedestals also require an interlock (**AMQTS2INT**) and counterweight (**AMQTS2CW**).*

Standard Includes	Required to Specify
<ul style="list-style-type: none"> <li>• Counterweight: black</li> <li>• Attachment hardware</li> </ul>	Style number

Specification Information	
• Style Number	• U.S. Price
AMQTS2CW	\$160

## Tektis Interlock

For Use with Tektis Fixed Pedestals

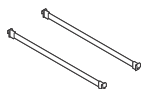


*When using a Tektis pedestal with a single pedestal desk, desks below 48"W require an interlock and a counterweight. Single pedestal desks with 28"D pedestals also require an interlock (**AMQTS2INT**) and counterweight (**AMQTS2CW**).*

Standard Includes	Required to Specify
<ul style="list-style-type: none"> <li>• Interlock: black</li> <li>• Attachment hardware</li> </ul>	Style number

Specification Information	
• Style Number	• U.S. Price
AMQTS2INT	\$56

## Rails



*Tip: Two rails per drawer accommodate side-to-side filing of letter-, A4-, and legal-size hanging folders.*

Standard Includes	Required to Specify
-------------------	---------------------

- Package of two rails: black only

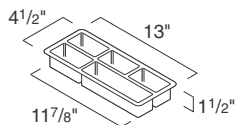
Style number

Specification Information		
Style Number	Width	U.S. Price

Style Number	Width	U.S. Price
<b>AMQRXADRL15</b>	12"	\$33

## Pencil Tray

For Use in Fixed Pedestals



*Tip: Pencil trays for use with fixed pedestals are available as optional accessories.*

Standard Includes	Required to Specify
-------------------	---------------------

- Pencil tray: black only

Style number

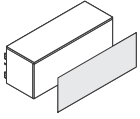
Specification Information	
Style Number	U.S. Price

Style Number	U.S. Price
<b>AMQRPXDP</b>	\$44



 **For Canadian Pricing**  
Multiply U.S. Price by the Canadian price factor.  
▶ See page 1 for details.

# Flexible Markerboard Surface



Tip: Used on TEKTIS overhead bins with flat fronts (AMQTSASUBL).

Standard Includes	Required to Specify
-------------------	---------------------

- |   |  |
|---|--|
| <ul style="list-style-type: none"> <li>Flexible, magnetic markerboard surface to attach to door of overhead storage bin: white plastic</li> </ul> | <ul style="list-style-type: none"> <li>Style number</li> </ul> |
|---|--|

Specification Information			
Style Number	Dimensions		U.S. Price
	W	H	

<b>AMQRMBB</b>	30"	16¼"	\$154
	36"	16¼"	\$163
	42"	16¼"	\$169
	48"	16¼"	\$178



**For Canadian Pricing**  
 Multiply U.S. Price by the Canadian price factor.  
 ▶ See page 1 for details.



# End-of-Run Boundary Screen

for Use with TEKTIS Monolithic Tackable Panels

*Tip: When attaching a boundary screen to a TEKTIS panel with a stacker segment, order a boundary screen and add a change-of-height trim when panel is taller than connecting screens.*

*Tip: Additional hardware upcharge is applied only when end-of-run spanning or end-of-run split style number is specified.*

*Tip: When specifying the paint finish for the bracket cover, select a finish that compliments the selected laminate finish or matches panel trim finish.*

*Tip: When specifying a boundary screen taller than the TEKTIS panel, order a change-of-height trim.*

Standard Includes	Required to Specify
<ul style="list-style-type: none"> <li>Screen: Low-Pressure Laminate</li> <li>Edge on laminate screen: plastic</li> <li>Trim finish: paint price group 1</li> <li>Attachment hardware</li> <li>Glides</li> </ul>	<ol style="list-style-type: none"> <li>Style number</li> <li>Additional hardware</li> <li>Handedness, if single-sided screen selected (see below under Required Selections)</li> <li>Low-Pressure Laminate color number for screen</li> <li>Paint color number for trim</li> <li>Options, if selected (see below)</li> </ol> <p>▶ See <i>Surface Materials</i>, page 506.</p>

Required Components	U.S. Price	Required to Specify
<b>Additional Hardware</b>		
• Split	+\$28	Specify with split hardware.
• Spanning	+\$35	Specify with spanning hardware.

Required Selections	U.S. Price	Required to Specify
<b>Handedness</b> (Single-Sided Screens only)		
• Right handed	No cost	Specify with right hand.
• Left handed	No cost	Specify with left hand.

Options	U.S. Price	Required to Specify
<b>Surface Materials</b>		
<b>Trim</b>		
• Paint price group 1	No cost	Specify paint color number.
• Paint price group 2	+\$14	Specify paint color number.
<b>Grain Direction</b>		
• No grain direction	No cost	Specify with no grain direction.
• Horizontal	No cost	Specify with horizontal grain direction.
• Vertical	No cost	Specify with vertical grain direction.

## Specification Information

Style Number	Dimensions Height	U.S. Base Prices								
		Width	24"W	30"W	36"W	42"W	48"W	54"W	60"W	66"W

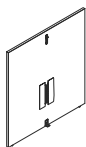
### Single-Sided

TKBSSSE	Height	24"W	30"W	36"W	42"W	48"W	54"W	60"W	66"W	72"W
	42"	\$532	\$612	\$670	\$745	\$808	\$861	\$ 904	\$ 936	\$ 957
	48"	\$559	\$669	\$729	\$808	\$875	\$929	\$ 973	\$1002	\$1021
	54"	\$574	\$684	\$780	\$861	\$929	\$984	\$1025	\$1053	\$1067

### Spanning

TKBSSPNE	Height	24"W	30"W	36"W	42"W	48"W	54"W	60"W	66"W	72"W
	28½"	N.A.	N.A.	N.A.	N.A.	\$722	N.A.	\$ 830	N.A.	\$ 909
	42"	N.A.	N.A.	N.A.	N.A.	\$808	N.A.	\$ 904	N.A.	\$ 957
	48"	N.A.	N.A.	N.A.	N.A.	\$875	N.A.	\$ 973	N.A.	\$1021
	54"	N.A.	N.A.	N.A.	N.A.	\$929	N.A.	\$1025	N.A.	\$1067

▶ **Specification Information, continued on next page**



*Tip: Trim varies between single sided and split/spanning screens. Single-sided screens are a spine bracket while the spanning/split screens are a cover.*



### For Canadian Pricing

Multiply U.S. Price by the Canadian price factor.

▶ See page 1 for details.

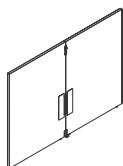
► Specification Information, continued from previous page

**Specification Information**

Style Number	Dimensions Height	U.S. Base Prices								
		Width								
		24"W	30"W	36"W	42"W	48"W	54"W	60"W	66"W	72"W

**Split**

TKBSSPTE	Dimensions Height	24"W	30"W	36"W	42"W	48"W	54"W	60"W	66"W	72"W
	28½"	N.A.	N.A.	\$584	\$656	\$722	\$780	\$ 830	\$ 874	\$ 909
	42"	N.A.	N.A.	\$670	\$745	\$808	\$861	\$ 904	\$ 936	\$ 957
	48"	N.A.	N.A.	\$729	\$808	\$875	\$929	\$ 973	\$1002	\$1021
	54"	N.A.	N.A.	\$780	\$861	\$929	\$984	\$1025	\$1053	\$1067



Tip: When specifying an end-of-run split boundary screen, two screen widths will need to be specified (left and right).



**For Canadian Pricing**  
Multiply U.S. Price by the Canadian price factor.  
► See page 1 for details.

# Middle-of-Run Boundary Screen

for Use with TEKTIS Monolithic Tackable Panels

*Tip: When attaching a boundary screen to a TEKTIS panel with a stacker segment, order a boundary screen and add a change-of-height trim when panel is taller than connecting screens.*

*Tip: Additional hardware upcharge is applied only when end-of-run spanning or end-of-run split style number is specified.*

*Tip: When specifying the paint finish for the bracket cover, select a finish that compliments the selected laminate finish or matches panel trim finish.*

*Tip: When specifying a boundary screen taller than the TEKTIS panel, order a change-of-height trim.*

Standard Includes	Required to Specify
<ul style="list-style-type: none"> <li>• Screen: Low-Pressure Laminate</li> <li>• Edge on laminate screen: plastic</li> <li>• Trim finish: paint price group 1</li> <li>• Top cap: paint price group 1</li> <li>• Attachment hardware</li> <li>• Glides</li> </ul>	<ol style="list-style-type: none"> <li>1 Style number</li> <li>2 Additional hardware</li> <li>3 Handedness, if single-sided screen selected (see below under Required Selections)</li> <li>4 Low-Pressure Laminate color number for screen</li> <li>5 Paint color number for trim</li> <li>6 Paint color number for top cap</li> <li>7 Options, if selected (see below)</li> </ol> <p>▶ See <i>Surface Materials</i>, page 506.</p>

Additional Hardware	Required Components	U.S. Price	Required to Specify
	• Split	+\$34	Specify with <i>split hardware</i> .
	• Spanning	+\$65	Specify with <i>spanning hardware</i> .

Surface Materials	Options	U.S. Price	Required to Specify
	<b>Trim</b>		
	• Paint price group 1	No cost	Specify paint color number.
	• Paint price group 2	+\$14	Specify paint color number.
	<b>Top cap</b>		
	• Paint price group 1	No cost	Specify paint color number.
	• Paint price group 2	+\$14	Specify paint color number.
<b>Grain Direction</b>	• No grain direction	No cost	Specify with <i>no grain direction</i> .
	• Horizontal	No cost	Specify with <i>horizontal grain direction</i> .
	• Vertical	No cost	Specify with <i>vertical grain direction</i> .

Specification Information		U.S. Base Prices								
Style Number	Dimensions Height	Width								
		24"W	30"W	36"W	42"W	48"W	54"W	60"W	66"W	72"W

## Single-Sided

TKBSSM	42"	48"	54"	60"	66"	72"	78"	84"	90"	96"	102"
	\$532	\$559	\$574	\$612	\$669	\$684	\$745	\$808	\$861	\$904	\$936
	\$670	\$729	\$780	\$808	\$875	\$929	\$984	\$1025	\$1067	\$1109	\$1151

▶ **Specification Information, continued on next page**



*Tip: When specifying the paint finish for the bracket cover, select a finish that compliments the selected laminate finish or matches panel trim finish.*



### For Canadian Pricing

Multiply U.S. Price by the Canadian price factor.

▶ See page 1 for details.

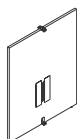
► **Specification Information, continued from previous page**

**Specification Information**

• Style Number	• Dimensions Height	• U.S. Base Prices									
		• Width									
		24"W	30"W	36"W	42"W	48"W	54"W	60"W	66"W	72"W	

**Spanning**

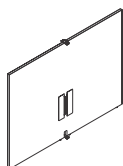
TKBSSPNM	Dimensions Height	24"W	30"W	36"W	42"W	48"W	54"W	60"W	66"W	72"W
	42"	N.A.	N.A.	N.A.	N.A.	\$808	N.A.	\$ 904	N.A.	\$ 957
	48"	N.A.	N.A.	N.A.	N.A.	\$875	N.A.	\$ 973	N.A.	\$1021
	54"	N.A.	N.A.	N.A.	N.A.	\$929	N.A.	\$1025	N.A.	\$1067



Tip: When specifying a middle-of-run split boundary screen, two screen widths will need to be specified (A and B).

**Split**

TKBSSPTM	Dimensions Height	24"W	30"W	36"W	42"W	48"W	54"W	60"W	66"W	72"W
	42"	N.A.	N.A.	\$670	\$745	\$808	\$861	\$ 904	\$ 936	\$ 957
	48"	N.A.	N.A.	\$729	\$808	\$875	\$929	\$ 973	\$1002	\$1021
	54"	N.A.	N.A.	\$780	\$861	\$929	\$984	\$1025	\$1053	\$1067



 **For Canadian Pricing**  
Multiply U.S. Price by the Canadian price factor.  
► See page 1 for details.

# L Return End-of-Run Boundary Screens

for Use with TEKTIS Monolithic Tackable Panels

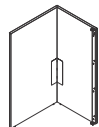
*Tip: When attaching a boundary screen to a TEKTIS panel with a stacker segment, order a boundary screen and add a change-of-height trim when panel is taller than connecting screens.*

*Tip: Additional hardware upcharge is applied only when end-of-run spanning or end-of-run split style number is specified.*

*Tip: When attaching boundary screens to a TEKTIS panel with a stacker segment, order a boundary screen and add a change-of-height trim.*

*Tip: When specifying the paint finish for the bracket cover, select a finish that compliments the selected laminate finish or matches panel trim finish.*

*Tip: When specifying a boundary screen taller than the TEKTIS panel, order a change-of-height trim.*



Standard Includes	Required to Specify
<ul style="list-style-type: none"> <li>Screen: Low-Pressure Laminate</li> <li>Edge on laminate screen: plastic</li> <li>Trim finish: paint price group 1</li> <li>Attachment hardware</li> <li>Glides</li> </ul>	<ol style="list-style-type: none"> <li>Style number</li> <li>Additional hardware</li> <li>Handedness, if single-sided screen selected (see below under Required Selections)</li> <li>Low-Pressure Laminate color number for screen</li> <li>Paint color number for trim</li> <li>Options, if selected (see below)</li> </ol> <p>▶ See <i>Surface Materials</i>, page 506.</p>

Required Components	U.S. Price	Required to Specify
<b>Additional Hardware</b>		
• Split	+\$28	Specify with <i>split hardware</i> .
• Spanning	+\$35	Specify with <i>spanning hardware</i> .

Required Selections	U.S. Price	Required to Specify
<b>Handedness</b> (Single-Sided Screens only)		
• Right handed	No cost	Specify with <i>right hand</i> .
• Left handed	No cost	Specify with <i>left hand</i> .

Options	U.S. Price	Required to Specify
<b>Surface Materials</b>		
<b>Trim</b>		
• Paint price group 1	No cost	Specify paint color number.
• Paint price group 2	+\$14	Specify paint color number.
<b>Grain Direction</b>		
• No grain direction	No cost	Specify with <i>no grain direction</i> .
• Horizontal	No cost	Specify with <i>horizontal grain direction</i> .
• Vertical	No cost	Specify with <i>vertical grain direction</i> .

## Specification Information

Style Number	Dimensions Height	U.S. Base Prices								
		Width								
		24"W	30"W	36"W	42"W	48"W	54"W	60"W	66"W	72"W

### Single-Sided


#### Primary Screen

TKBSSSEL	Height	24"W	30"W	36"W	42"W	48"W	54"W	60"W	66"W	72"W
	42"	\$532	\$612	\$670	\$745	\$808	\$861	\$ 904	\$ 936	\$ 957
	48"	\$559	\$669	\$729	\$808	\$875	\$929	\$ 973	\$1002	\$1021
	54"	\$574	\$684	\$780	\$861	\$929	\$984	\$1025	\$1053	\$1067

#### Return Screen

TKBSSSEL	Height	24"W	30"W	36"W	42"W	48"W	54"W	60"W	66"W	72"W
	42"	\$532	\$612	N.A.	N.A.	N.A.	N.A.	N.A.	N.A.	N.A.
	48"	\$559	\$669	N.A.	N.A.	N.A.	N.A.	N.A.	N.A.	N.A.
	54"	\$574	\$684	N.A.	N.A.	N.A.	N.A.	N.A.	N.A.	N.A.

▶ Specification Information, continued on next page

 **For Canadian Pricing**  
Multiply U.S. Price by the Canadian price factor.  
▶ See page 1 for details.

► **Specification Information, continued from previous page**

**Specification Information**

Style Number	Dimensions Height	U.S. Base Prices									
		Width									
		24"W	30"W	36"W	42"W	48"W	54"W	60"W	66"W	72"W	

**Spanning**

**Primary Screen**

TKBSSPNEL	28½"	N.A.	N.A.	N.A.	N.A.	\$722	N.A.	\$ 830	N.A.	\$ 909
	42"	N.A.	N.A.	N.A.	N.A.	\$808	N.A.	\$ 904	N.A.	\$ 957
	48"	N.A.	N.A.	N.A.	N.A.	\$875	N.A.	\$ 973	N.A.	\$1021
	54"	N.A.	N.A.	N.A.	N.A.	\$929	N.A.	\$1025	N.A.	\$1067

**Return Screen**

TKBSSPNEL	28½"	\$447	\$523	N.A.	N.A.	N.A.	N.A.	N.A.	N.A.	N.A.
	42"	\$532	\$612	N.A.	N.A.	N.A.	N.A.	N.A.	N.A.	N.A.
	48"	\$559	\$669	N.A.	N.A.	N.A.	N.A.	N.A.	N.A.	N.A.
	54"	\$574	\$684	N.A.	N.A.	N.A.	N.A.	N.A.	N.A.	N.A.

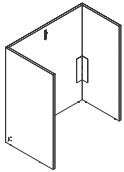
**Split**

**Primary Screen**

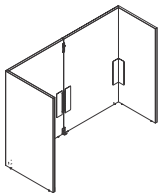
TKBSSPTEL	28½"	N.A.	N.A.	\$584	\$656	\$722	\$780	\$ 830	\$ 874	\$ 909
	42"	N.A.	N.A.	\$670	\$745	\$808	\$861	\$ 904	\$ 936	\$ 957
	48"	N.A.	N.A.	\$729	\$808	\$875	\$929	\$ 973	\$1002	\$1021
	54"	N.A.	N.A.	\$780	\$861	\$929	\$984	\$1025	\$1053	\$1067

**Return Screen**

TKBSSPTEL	28½"	\$447	\$523	N.A.	N.A.	N.A.	N.A.	N.A.	N.A.	N.A.
	42"	\$532	\$612	N.A.	N.A.	N.A.	N.A.	N.A.	N.A.	N.A.
	48"	\$559	\$669	N.A.	N.A.	N.A.	N.A.	N.A.	N.A.	N.A.
	54"	\$574	\$684	N.A.	N.A.	N.A.	N.A.	N.A.	N.A.	N.A.



Tip: Returns on spanning boundary screens will always be mirrored.



Tip: When specifying a split L return boundary screen, four screen widths will need to be specified.



**For Canadian Pricing**  
Multiply U.S. Price by the Canadian price factor.  
► See page 1 for details.

# L Return Middle-of-Run Boundary Screens

for Use with TEKTIS Monolithic Tackable Panels

*Tip: When specifying an L return boundary screen, primary and return screen widths need to be specified. The final price will include the price of both individual screen segments.*

*Tip: Additional hardware upcharge is applied only when middle-of-run L return spanning or middle-of-run L return split style number is specified.*

*Tip: When attaching boundary screens to a TEKTIS panel with a stacker segment, order a boundary screen and add a change-of-height trim.*

*Tip: When specifying a boundary screen taller than the TEKTIS panel, order a change-of-height trim.*

*Tip: When specifying the paint finish for the bracket cover, select a finish that compliments the selected laminate finish or matches panel trim finish.*

Standard Includes	Required to Specify
<ul style="list-style-type: none"> <li>Screen: Low-Pressure Laminate</li> <li>Edge on laminate screen: plastic</li> <li>Trim finish: paint price group 1</li> <li>Top cap: paint</li> <li>Attachment hardware</li> <li>Glides</li> </ul>	<ol style="list-style-type: none"> <li>Style number</li> <li>Additional hardware</li> <li>Handedness, if single-sided screen selected (see below under Required Selections)</li> <li>Low-Pressure Laminate color number for screen</li> <li>Paint color number for trim</li> <li>Paint color number for top cap</li> <li>Options, if selected (see below)</li> </ol> <p>► See <i>Surface Materials</i>, page 506.</p>

Required Components	U.S. Price	Required to Specify
<b>Additional Hardware</b>		
• Split	+\$34	Specify with split hardware.
• Spanning	+\$65	Specify with spanning hardware.

Required Selections	U.S. Price	Required to Specify
<b>Handedness</b> (Single-Sided Screens only)		
• Right handed	No cost	Specify with right hand.
• Left handed	No cost	Specify with left hand.

Options	U.S. Price	Required to Specify
<b>Surface Materials</b>		
<b>Trim</b>		
• Paint price group 1	No cost	Specify paint color number.
• Paint price group 2	+\$14	Specify paint color number.
<b>Top cap</b>		
• Paint price group 1	No cost	Specify paint color number.
• Paint price group 2	+\$14	Specify paint color number.
<b>Grain Direction</b>		
• No grain direction	No cost	Specify with no grain direction.
• Horizontal	No cost	Specify with horizontal grain direction.
• Vertical	No cost	Specify with vertical grain direction.

Specification Information		U.S. Base Prices								
Style Number	Dimensions Height	Width								
		24"W	30"W	36"W	42"W	48"W	54"W	60"W	66"W	72"W

## Single-Sided

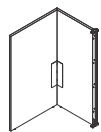
### Primary Screen

TKBSSML	42"	48"	54"	60"	66"	72"
	\$532	\$559	\$574	\$612	\$669	\$684
	\$670	\$729	\$780	\$808	\$875	\$929
	\$745	\$808	\$861	\$881	\$929	\$984
	\$808	\$875	\$929	\$984	\$1025	\$1067

### Return Screen

TKBSSML	42"	48"	54"	60"	66"	72"
	\$532	\$559	\$574	N.A.	N.A.	N.A.
	\$612	\$669	\$684	N.A.	N.A.	N.A.
	N.A.	N.A.	N.A.	N.A.	N.A.	N.A.

► Specification Information, continued on next page



**For Canadian Pricing**  
Multiply U.S. Price by the Canadian price factor.  
► See page 1 for details.

► Specification Information, continued from previous page

**Specification Information**

Style Number	Dimensions Height	U.S. Base Prices								
		Width								
		24"W	30"W	36"W	42"W	48"W	54"W	60"W	66"W	72"W

**Spanning**

**Primary Screen**

TKBSSPNML	42"	N.A.	N.A.	N.A.	N.A.	\$808	N.A.	\$ 904	N.A.	\$ 957
	48"	N.A.	N.A.	N.A.	N.A.	\$875	N.A.	\$ 973	N.A.	\$1021
	54"	N.A.	N.A.	N.A.	N.A.	\$929	N.A.	\$1025	N.A.	\$1067

**Return Screen**

TKBSSPNML	42"	\$532	\$612	N.A.	N.A.	N.A.	N.A.	N.A.	N.A.	N.A.
	48"	\$559	\$669	N.A.	N.A.	N.A.	N.A.	N.A.	N.A.	N.A.
	54"	\$574	\$684	N.A.	N.A.	N.A.	N.A.	N.A.	N.A.	N.A.

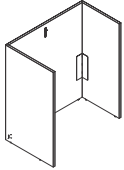
**Split**

**Primary Screen**

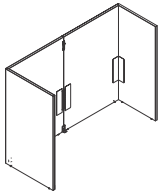
TKBSSPTML	42"	N.A.	N.A.	\$670	\$745	\$808	\$861	\$ 904	\$ 936	\$ 957
	48"	N.A.	N.A.	\$729	\$808	\$875	\$929	\$ 973	\$1002	\$1021
	54"	N.A.	N.A.	\$780	\$861	\$929	\$984	\$1025	\$1053	\$1067

**Return Screen**

TKBSSPTML	42"	\$532	\$612	N.A.	N.A.	N.A.	N.A.	N.A.	N.A.	N.A.
	48"	\$559	\$669	N.A.	N.A.	N.A.	N.A.	N.A.	N.A.	N.A.
	54"	\$574	\$684	N.A.	N.A.	N.A.	N.A.	N.A.	N.A.	N.A.



Tip: Returns on spanning boundary screens will always be mirrored.

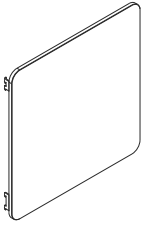


Tip: When specifying a split L return boundary screen, four screen widths will need to be specified.



**For Canadian Pricing**  
Multiply U.S. Price by the Canadian price factor.  
► See page 1 for details.

# Hanging Markerboard



*Tip: Hanging markerboards may span more than one panel.*

*Tip: Hanging markerboards may be used with TEKTIS wall channels.*

Standard Includes	Required to Specify
<ul style="list-style-type: none"> <li>• Markerboard height: 24"H</li> </ul>	Style number

Specification Information		
• Style Number	• Width	• U.S. Price
<b>TKHMB</b>	24"	\$343
	30"	\$369
	36"	\$396
	42"	\$448
	48"	\$475
	60"	\$528



**For Canadian Pricing**  
 Multiply U.S. Price by the Canadian price factor.  
 ▶ See page 1 for details.

## Paint

*Tip: All products may not be available in all colors listed below.*

### Price Group 1

Applies to:

- Pulls

### Textured Paint

7207 Black

Applies to:

- Cable pole
- Laminate common shelf brackets
- New York base-in power
- Panel trim
- Power pole
- Vertical trim
- Boundary screens

### Textured Paint

7207 Black  
7225 Sand  
7238 Fieldstone  
7243 Seagull

Applies to:

- Cantilever
- End panel
- Fixed pedestal
- Pedestal filler
- Post legs
- Boundary screens

### Textured Paint

7207 Black  
7243 Seagull

Applies to:

- Cable pole
- Cantilever
- End panel
- Fixed pedestal
- Laminate common shelf brackets
- New York base-in power
- Panel trim
- Pedestal pillar
- Post legs
- Power pole
- Pulls
- Vertical trim

### Price Group 2

### Smooth Metallic Paint

4799 Platinum Metallic

## Laminate

Applies to:

- Boundary screens
- Laminate common shelf
- Worksurfaces

### Low-Pressure Laminate

24L0 Graphite Walnut  
25L5 Virginia Walnut LPL  
25L8 Clear Walnut LPL  
26L1 Natural Cherry V2 LPL  
2L09 Clear Maple LPL  
2L30 Arctic White LPL  
2L83 Seagull LPL  
2L84 Milk LPL  
2LAK Clear Oak  
2LAT Acacia LPL  
2LCN Clay Noce LPL  
2LCW Clay Wenge LPL

## Plastic

6009 Arctic White  
6034 Natural Cherry  
6052 Milk  
6053 Seagull  
6213 Acacia  
6219 Clear Oak  
6231 Graphite  
6237 Clear Maple  
6242 Virginia Walnut  
6245 Clear Walnut  
6706 Clay Wenge  
6709 Clay Noce

*Tip: Light color plastic edges are susceptible to degradation due to normal wear and tear. Staining (e.g., ball point pen or clothing dyes such as blue jeans) and dirt effects are more pronounced in light colors and are not considered defects.*

Applies to:

- Laminate common shelf
  - Worksurfaces
- 6009 Arctic White  
6034 Natural Cherry  
6052 Milk  
6053 Seagull  
6213 Acacia  
6219 Clear Oak  
6231 Graphite Walnut  
6237 Clear Maple  
6242 Virginia Walnut  
6245 Clear Walnut  
6706 Clay Wenge  
6709 Clay Noce

## Metal

Applies to:

- Bins
- 9201 Polished Chrome

## Surface Fabric

Applies to:

- Monolithic panels
- Stacker panels

### Alloy

P525 Polar  
P526 Skim  
P527 Bubbly  
P528 Tern  
P529 Shore  
P530 Asti  
P531 Silver  
P532 Oxide  
P533 Element  
P534 Construct  
P535 Currency  
P536 Iron

### Boccie

P200 New Rice  
P201 New Almond  
P203 New Camel  
P204 New Opal  
P205 New Mist  
P206 New Plum  
P208 New Spearmint  
P209 New Sky

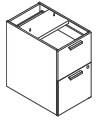


# EMBANK

			
<b>Statement of Line</b>	<b>290</b>	<b>Specifying</b>	
			
<b>Product Details</b>			
Fixed and Mobile Pedestals	<b>300</b>	Fixed Pedestals	<b>344</b>
One-High, 1.5-High, and Two-High Lateral Files and Lower Storage	<b>302</b>	Mobile Pedestals	<b>345</b>
Three-High and Four-High Lateral Files	<b>304</b>	One-High, 1.5-High, and Two-High Lateral Files	<b>346</b>
Credenzas	<b>306</b>	Three-High and Four-High Lateral Files	<b>347</b>
Common Top	<b>309</b>	One-High, 1.5-High, and Two-High Lower Storage	<b>348</b>
Desks, Desk Shells, Returns, Return Shells, and Bridge	<b>310</b>	Cushions	<b>349</b>
D-Shape and P-Shape Worksurfaces	<b>314</b>	Credenzas	<b>350</b>
Towers and Wardrobes	<b>316</b>	Common Top	<b>353</b>
Bookcases	<b>318</b>	Desks and Desk Shells	<b>354</b>
Overheads and Organizer	<b>320</b>	Returns and Return Shells	<b>356</b>
Tackboard	<b>322</b>	Bridge	<b>357</b>
Tables	<b>323</b>	D-Shape and P-Shape Worksurfaces	<b>358</b>
<b>Application Topics</b>		Towers	<b>359</b>
Table Tops, Legs, and Base Combinations	<b>330</b>	Wardrobes	<b>362</b>
Rectangular Conference Table Power Unit	<b>332</b>	Bookcases	<b>363</b>
Directional Laminate and Edge Profile Detail	<b>333</b>	Overheads and Organizer	<b>365</b>
Storage Capacities and Dimensions	<b>334</b>	Tackboard	<b>368</b>
Finish Availability Matrix	<b>343</b>	Tables	<b>369</b>
		Leg and Table Base	<b>375</b>
		Modesty Panel	<b>376</b>
		Accessories	<b>377</b>
			
		<b>Resources</b>	<b>379</b>

# Statement of Line

## EMBANK



Understanding  
 ▶ Page 300  
 Specifying  
 ▶ Page 344



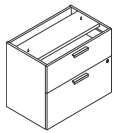
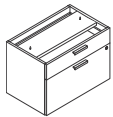
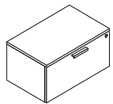
Understanding  
 ▶ Page 300  
 Specifying  
 ▶ Page 345

### EMBANK Fixed Pedestal

	15 <sup>3</sup> / <sub>4</sub> "W
27 <sup>5</sup> / <sub>16</sub> "H	●

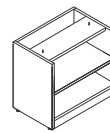
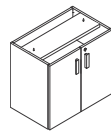
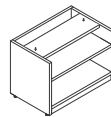
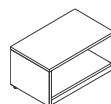
### EMBANK Mobile Pedestals

	15 <sup>3</sup> / <sub>4</sub> "W
23 <sup>2</sup> / <sub>3</sub> "H	●
27 <sup>3</sup> / <sub>32</sub> "H	●



Understanding  
 ▶ Page 302  
 Specifying  
 ▶ Page 346

\* The case on One-High, 1.5-High, and Two-High open units is 18<sup>7</sup>/<sub>8</sub>"D and 24"D for lateral files  
 \* The case on Two-High units can be 22<sup>3</sup>/<sub>4</sub>"D for lateral files.  
 \* The top matches the depth of units with drawers and doors.



Understanding  
 ▶ Page 302  
 Specifying  
 ▶ Page 348

\*The case on One-High, 1.5-High, and Two-High open units is 18<sup>7</sup>/<sub>8</sub>"D and 24"D for lower storage.  
 \*The case on Two-High units can be 22<sup>3</sup>/<sub>4</sub>"D for lower storage.  
 \*The top matches the depth of units with drawers and doors.

### EMBANK Lateral Files

		30"W	36"W
<b>One-High</b>	15 <sup>3</sup> / <sub>8</sub> "H	●	●
<b>1.5-High</b>	21 <sup>3</sup> / <sub>8</sub> "H	●	●
<b>Two-High</b>	27 <sup>5</sup> / <sub>16</sub> "H	●	●

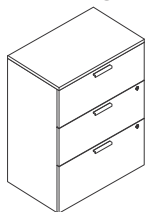
Tip: Height is without top. The One-High Embank lateral is available with top only. Tops can be optioned off for ganged applications.

### EMBANK Lower Storage

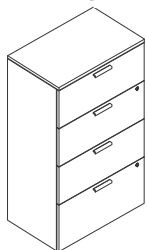
		30"W	36"W
<b>One-High</b>	15 <sup>3</sup> / <sub>8</sub> "H	●	●
<b>1.5-High</b>	21 <sup>3</sup> / <sub>8</sub> "H	●	●
<b>Two-High</b>	27 <sup>5</sup> / <sub>16</sub> "H	●	●

Tip: Height is without top. The One-High Embank lower storage is available with top only. Tops can be optioned off for ganged applications.

**Three-High**



**Four-High**



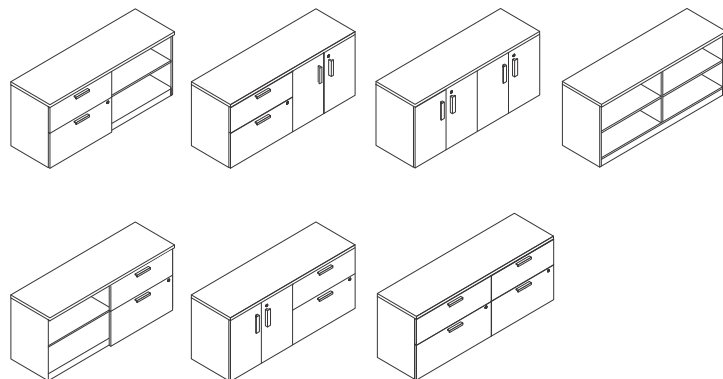
Understanding  
 ▶ Page 304  
 Specifying  
 ▶ Page 347

**EMBANK Three-High and Four-High Lateral Files**

		30"W	36"W
<b>Three-High</b>	40 <sup>1</sup> / <sub>3</sub> "H	●	●
<b>Four-High</b>	52 <sup>1</sup> / <sub>3</sub> "H	●	●

*Tip: Three-High and Four-High laterals are available with top only.*

**Two-High**



Understanding  
 ▶ Page 306  
 Specifying  
 ▶ Page 350

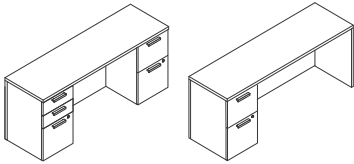
**EMBANK Full Storage Credenzas**

	60"W	66"W	72"W
27 <sup>5</sup> / <sub>16</sub> "H	●	●	●

*Tip: Height is shown without top. Top can be optioned on.*



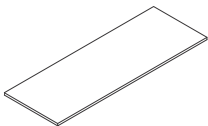
Statement of Line, EMBANK, continued



Understanding  
 ▶ Page 306  
 Specifying  
 ▶ Page 352

**EMBAK Credenzas with Kneespace**

	66"W	72"W
24"D	●	●

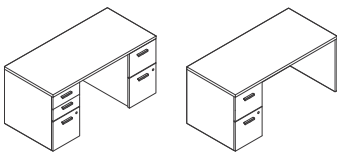


Understanding  
 ▶ Page 309  
 Specifying  
 ▶ Page 353

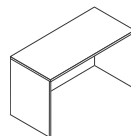
**EMBAK Common Tops**

	45 <sup>11</sup> / <sub>16</sub> "W	51 <sup>11</sup> / <sub>16</sub> "W	59 <sup>3</sup> / <sub>4</sub> "W	65 <sup>3</sup> / <sub>4</sub> "W	71 <sup>3</sup> / <sub>4</sub> "W	89 <sup>9</sup> / <sub>16</sub> "W	89 <sup>13</sup> / <sub>16</sub> "W	95 <sup>13</sup> / <sub>16</sub> "W
18 <sup>7</sup> / <sub>8</sub> "D	●	●	●	●	●	●	●	●
24"D	●	●	●	●	●	●	●	●
30"D	●	●	●	●	●	●	●	●

Tip: Common Top thickness is equal to 1<sup>1</sup>/<sub>8</sub>".



Understanding  
 ▶ Page 310  
 Specifying  
 ▶ Page 354



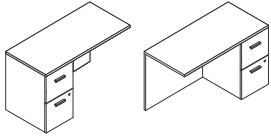
Understanding  
 ▶ Page 310  
 Specifying  
 ▶ Page 354

**EMBAK Desks with Pedestals**

	60"W	66"W	72"W
30"D	●	●	●
36"D			●

**EMBAK Desk Shells**

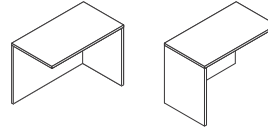
	60"W	66"W	72"W
24"D	●	●	●
30"D	●	●	●
36"D			●



Understanding  
 ▶ Page 310  
 Specifying  
 ▶ Page 356

### EMBANK Returns with Pedestal

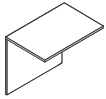
	42"W	48"W
24"D	●	●



Understanding  
 ▶ Page 310  
 Specifying  
 ▶ Page 310

### EMBANK Return Shells

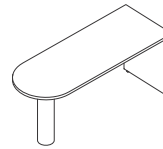
	42"W	48"W
24"D	●	●



Understanding  
 ▶ Page 310  
 Specifying  
 ▶ Page 357

### EMBANK Bridges

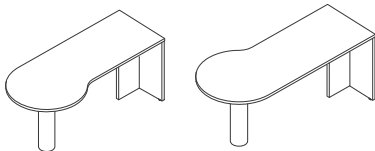
	36"W	42"W	48"W
24"D	●	●	●



Understanding  
 ▶ Page 314  
 Specifying  
 ▶ Page 358

### EMBANK D-Shape Worksurfaces

	60"W	66"W	72"W
30"D	●	●	●
36"D	●	●	●



Right-hand unit

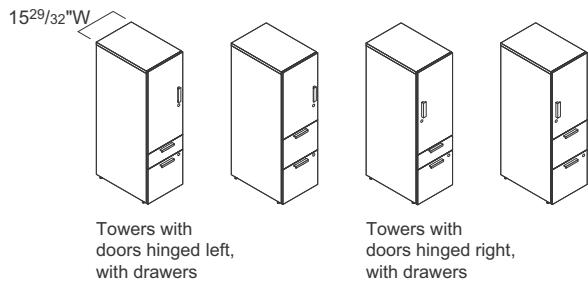
Left-hand unit

Understanding  
 ▶ Page 314  
 Specifying  
 ▶ Page 358

### EMBANK P-Shape Worksurfaces

		60"W	66"W	72"W
<b>Depth B</b>	30"D, 36"D, 42"D	●	●	●
<b>Depth C</b>	24"D, 30"D, 36"D	●	●	●

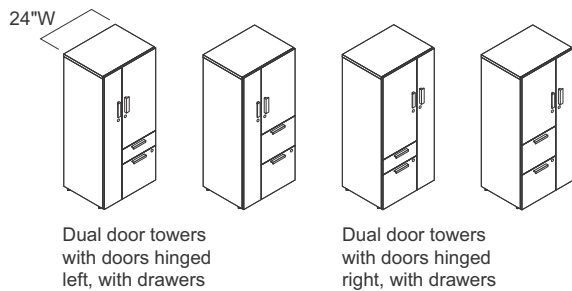
Statement of Line, EMBANK, continued



Understanding  
 ▶ Page 316  
 Specifying  
 ▶ Page 359

**EMBANK Single-Door Towers**

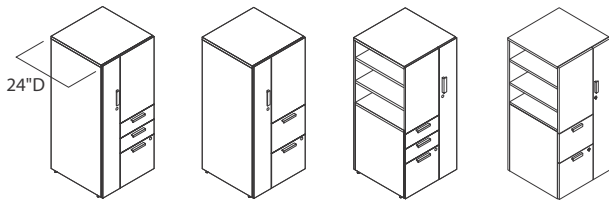
	15 <sup>29</sup> / <sub>32</sub> "W
41 <sup>25</sup> / <sub>32</sub> "H	●
47 <sup>31</sup> / <sub>32</sub> "H	●
54 <sup>1</sup> / <sub>8</sub> "H	●
66 <sup>1</sup> / <sub>2</sub> "H	●



Understanding  
 ▶ Page 316  
 Specifying  
 ▶ Page 360

**EMBANK Dual-Door Towers**

	24"W
41 <sup>25</sup> / <sub>32</sub> "H	●
47 <sup>31</sup> / <sub>32</sub> "H	●
54 <sup>1</sup> / <sub>8</sub> "H	●
66 <sup>1</sup> / <sub>2</sub> "H	●



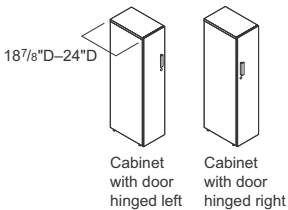
Side access towers with doors hinged left, with drawers

Side access towers with doors hinged right, with drawers

Understanding  
 ▶ Page 316  
 Specifying  
 ▶ Page 361

### EMBANK Side Access Towers

	24"W
41 <sup>25</sup> / <sub>32</sub> "H	●
47 <sup>31</sup> / <sub>32</sub> "H	●
54 <sup>1</sup> / <sub>8</sub> "H	●
66 <sup>1</sup> / <sub>2</sub> "H	●



Cabinet with door hinged left

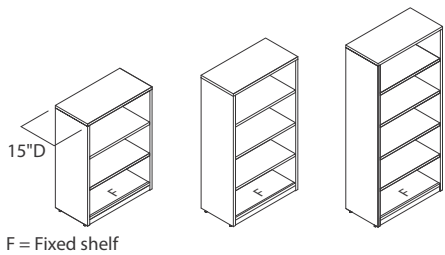
Cabinet with door hinged right

Understanding  
 ▶ Page 316  
 Specifying  
 ▶ Page 362

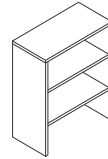
### EMBANK Wardrobes

	12"W
41 <sup>25</sup> / <sub>32</sub> "H	●
47 <sup>31</sup> / <sub>32</sub> "H	●
54 <sup>1</sup> / <sub>8</sub> "H	●

Statement of Line, EMBANK, continued



Understanding  
 ▶ Page 318  
 Specifying  
 ▶ Page 363



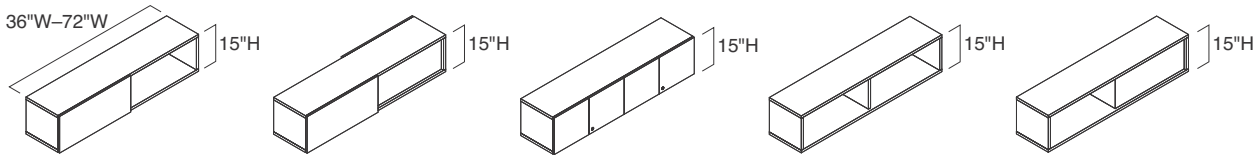
Understanding  
 ▶ Page 318  
 Specifying  
 ▶ Page 364

**EMBAK Bookcases**

	30"W	36"W
41 <sup>25</sup> / <sub>32</sub> "H	●	●
47 <sup>31</sup> / <sub>32</sub> "H	●	●
54 <sup>1</sup> / <sub>8</sub> "H	●	●
66 <sup>1</sup> / <sub>2</sub> "H	●	●
72 <sup>11</sup> / <sub>16</sub> "H	●	●

**EMBAK Stacking Bookcases**

	30"W	36"W
25 <sup>5</sup> / <sub>8</sub> "H	●	●
37 <sup>31</sup> / <sub>32</sub> "H	●	●
44 <sup>3</sup> / <sub>16</sub> "H	●	●



Overhead with sliding door

Overhead with sliding door, shared

Overhead with hinged doors

Overhead with open front

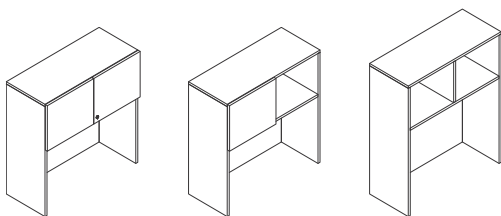
Overhead with open front, shared

Understanding  
 ▶ Page 320  
 Specifying  
 ▶ Page 365

**EMBAK Overheads with Sliding Doors, Hinged Doors, or Open Fronts**

	36"W	42"W	48"W	54"W	60"W	66"W	72"W
15"D without doors	●	●	●	●	●	●	●
16"D with doors	●	●	●	●	●	●	●

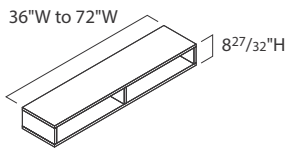
Tip: Height of overheads when specified with panel mount option is 15<sup>7</sup>/<sub>16</sub>"H.



Understanding  
 ▶ Page 320  
 Specifying  
 ▶ Page 366

**EMBAK Stacking Overheads with Hinged Doors, Sliding Doors, or Open Fronts**

	60"W	66"W	72"W
15"D without doors	●	●	●
16"D with doors	●	●	●



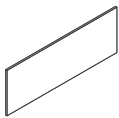
Personal Organizer

Understanding  
 ▶ Page 320  
 Specifying  
 ▶ Page 367

### EMBANK Organizers

	36"W	42"W	48"W	54"W	60"W	66"W	72"W
15"D Personal	●	●	●	●	●	●	●

*Tip: Height of organizers when specified with no bracket option is 8<sup>27</sup>/<sub>32</sub>"H.*  
*Tip: 72"W organizers have three equal-spaced vertical supports.*

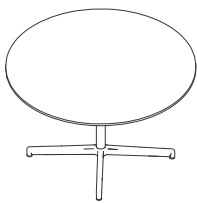


Understanding  
 ▶ Page 322  
 Specifying  
 ▶ Page 368

### EMBANK Tackboards

	36"W	42"W	48"W	60"W	66"W	72"W
20 <sup>1</sup> / <sub>4</sub> "H	●	●	●	●	●	●
26 <sup>1</sup> / <sub>4</sub> "H	●	●	●	●	●	●

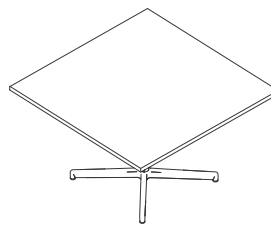
*Tip: Tackboard thickness is equal to 1".*  
*Tip: Tackboard thickness includes a core tackboard, spacer, and attachment hardware.*



Understanding  
 ▶ Page 323  
 Specifying  
 ▶ Page 369

### EMBANK Social Table—Round

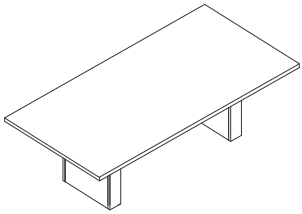
	36" Dia.	48" Dia.
28"H	●	●



Understanding  
 ▶ Page 323  
 Specifying  
 ▶ Page 369

### EMBANK Social Table—Square

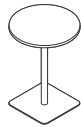
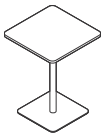
	36"W	48"W
28"H	●	●



Understanding  
 ▶ Page 324  
 Specifying  
 ▶ Page 370

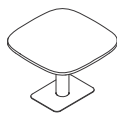
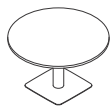
**EMBANK Conference Tables—Rectangle**

	72"W	96"W	120"W	144"W
36 <sup>1</sup> / <sub>4</sub> "D	●	●	●	●
48"D	●	●	●	●



Understanding  
 ▶ Page 326  
 Specifying  
 ▶ Page 371

**EMBANK Café Height Table—Square or Round**



Understanding  
 ▶ Page 326  
 Specifying  
 ▶ Pages 372 and 373

**EMBANK Collaborative Table—Square or Round**



Understanding  
 ▶ Page 332  
 Specifying  
 ▶ Page 374

**Power**



Specifying  
 ▶ Page 375

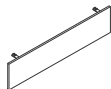
**EMBANK Leg and Table Base—Square Leg**

2"W

27<sup>1</sup>/<sub>4</sub>"H ●

*Tip: Square leg is 2" in depth.*

*Tip: Pair four legs with an Embank common top to create a table top desk or two legs to support an Embank return worksurface.*



Specifying  
 ▶ Page 376

**EMBANK Modesty Panel**

	36"W	48"W	60"W
13 <sup>3</sup> / <sub>4</sub> "H	●	●	●

# EMBANK Pedestals

Fixed and Mobile

**Fixed pedestals** are floor standing and can support worksurfaces at 27<sup>11</sup>/<sub>32</sub>"H.  
 ▶ Specifying, page 359–345

**Top** is open on fixed pedestals and accommodates attachment to a work surface. Attachment hardware is included.

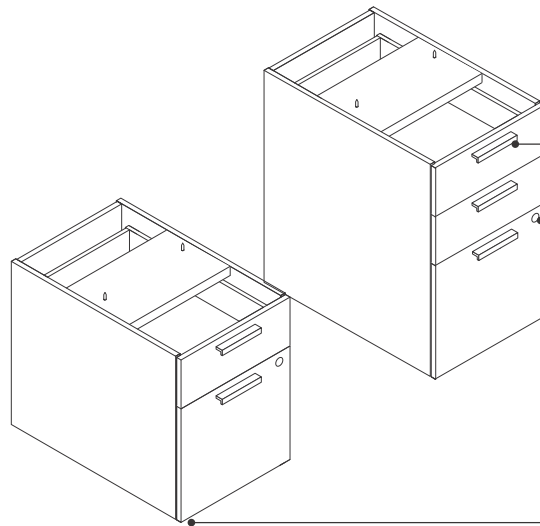
**Drawer fronts** are available in Low-Pressure Laminate and are full to the bottom of the case (no toe kick).

**Finished back and sides** are standard on pedestals.

**File drawers** open their full depth for total access to the contents and have an integrated U-channel on the drawer bodies for hanging file folder frames.

**Mobile pedestals** can be moved wherever storage is needed. They provide an auxiliary worksurface when you need more space to spread out your work.  
 ▶ Specifying, page 345

**Top on mobile pedestal** is 1<sup>1</sup>/<sub>8</sub>" thick and is available in Low-Pressure Laminate.

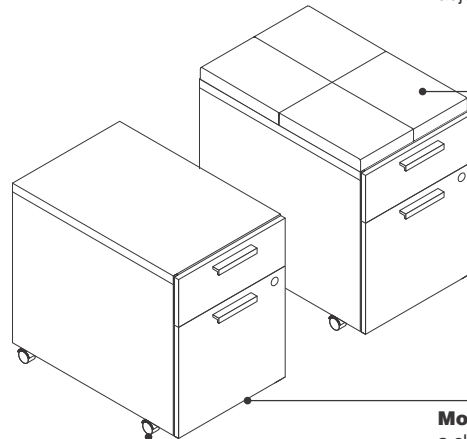


**Pulls on pedestals** are available in a ledge style only.

**Lock** is standard on pedestals. Lock is located in the bottom drawer, and locks the drawer it is located in and the one above. Locks are standard on lateral files and secure all drawers. Lock cylinders are field-installed.

**Standard lock cylinders and keys** are included with Embank pedestals. If a master key is optioned, **AMQLOCK9201XF** must be specified to be included. All lock cylinders are field-installed.

**Leveling glides** adjust to install pedestals on uneven floors and have a 1<sup>1</sup>/<sub>2</sub>" adjustable glide range.



**Mobile pedestal cushion top** provides a temporary seat ideal for informal gatherings. Cushion top is ordered separately and requires field installation.

▶ Specifying, page 345  
*Tip: Two-High mobile pedestals with a cushion top will not fit under a desk.*

**Mobile pedestals** have a clearance of 2.6" from the ground to the underside of the pedestal.

**Four casters** are hard composition and non-locking, with a full-rotation swivel.

## Actual Dimensions

	Mobile Pedestals Box/File
<b>Depth</b>	18 <sup>7</sup> / <sub>8</sub> " and 22"
<b>Width</b>	15 <sup>3</sup> / <sub>4</sub> "
<b>Height</b>	23 <sup>2</sup> / <sub>3</sub> "

	Fixed Pedestals Box/Box/File and File/File
<b>Depth</b>	24" and 30"
<b>Width</b>	15 <sup>3</sup> / <sub>4</sub> "
<b>Height</b>	27 <sup>5</sup> / <sub>16</sub> "

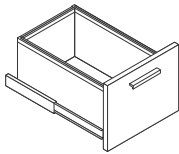
	Mobile Pedestals Box/Box/File and File/File
<b>Depth</b>	22"
<b>Width</b>	15 <sup>3</sup> / <sub>4</sub> "
<b>Height</b>	27 <sup>3</sup> / <sub>32</sub> "

*Tip: 2-High mobile pedestals without a cushion fit under an Embank desk shell.*

*Tip: 2-High mobile pedestals with a cushion top do not fit under an Embank desk shell.*

**Product Details**

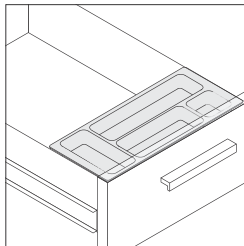
**Box drawers** are black, bore and dowel construction.



**File drawer body** is standard with integrated U-channel to accommodate hanging folder files.

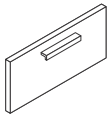
**All pedestal file drawers** accommodate front-to-back and side-to-side letter filing.

**24"D and 30"D pedestal file drawers** also accommodate side-to-side legal filing.



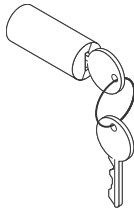
**Pencil tray to hold small office supplies** is standard with pedestals with box drawers.

**27<sup>5</sup>/<sub>16</sub>"H fixed pedestal** can be used in combination with other Two-High lower storage to create a variety of storage options.

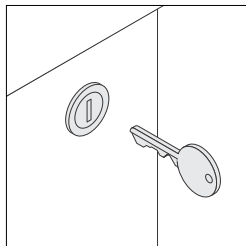


Ledge pull

**Pulls** are available in a ledge style only.



**Lock cylinders** are field-installed. Pedestals are shipped installed with plugs, with lock cylinders separate.

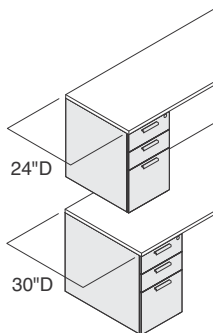


▶ Lock and Keying, page 380

**Counterweight packages** are included and required to ensure product stability.

**Mobile pedestal cushion top** is field installed with screws. See assembly instructions for details.

**Connections**



**Fixed pedestals** are intended to attach under a worksurface for security and support. Pedestals can be paired with EMBANK common top.

**Fixed pedestals** are not to be used alone as a free-standing unit, and must be used with other furniture.

**Pedestals using common tops** must be attached to other storage, a perpendicular worksurface, or a panel. A maximum 6" overhang of the worksurface is allowed on either side, or back.

**Surface Materials**

**EMBANK storage** can be specified with contrasting case, headset, top laminate finishes, and edgeband.

**Pedestal case, headsets, and top**

- 24L0 Graphite Walnut
- 25L5 Virginia Walnut
- 25L8 Clear Walnut
- 26L1 Natural Cherry
- 2L09 Clear Maple
- 2L30 Arctic White
- 2L83 Seagull
- 2L84 Milk
- 2LAK Clear Oak
- 2LAT Acacia
- 2LAW Ash Wenge
- 2LCN Clay Noce
- 2LCW Clay Wenge

**Ledge pull**

- 4799 Platinum Metallic
- 7207 Black

**Lock**

- 9201 Polished Chrome

**Drawer bodies, drawer suspensions, and glides**

- Black

**Cushion top**

- Upholstery

**Application Topics**

**Storage capacities and dimensions**

▶ Page 334

# EMBANK One-High, 1.5-High, and Two-High Lower Storage and Lateral Files

**One-High, 1.5-High, and Two-High EMBANK lower storage and lateral files** are floor standing and can support worksurfaces at 15<sup>3</sup>/<sub>8</sub>"H, 21<sup>3</sup>/<sub>8</sub>"H, or 27<sup>5</sup>/<sub>16</sub>"H.

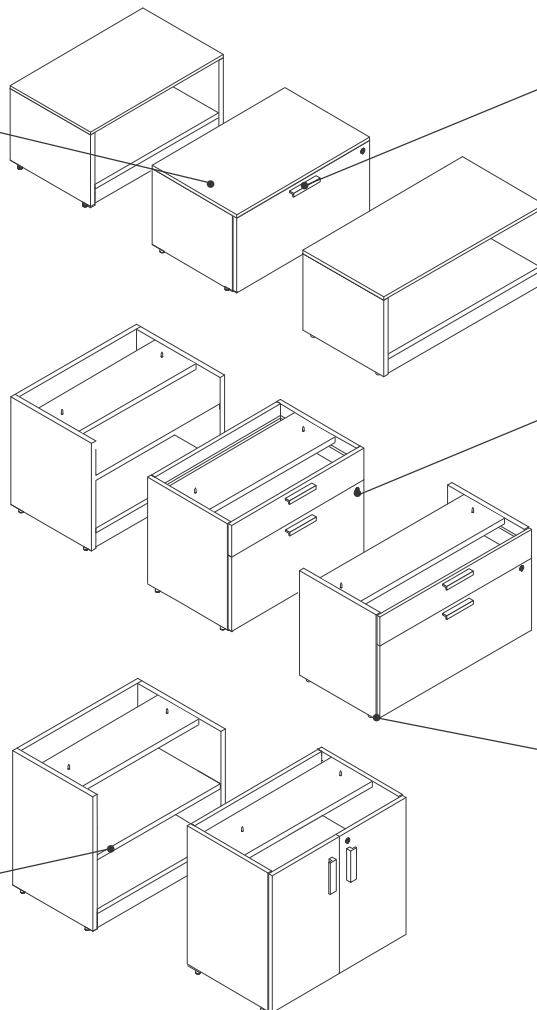
**Top** are 1<sup>1</sup>/<sub>8</sub>" thick and come standard on Embank One-High Storage. They can be optioned on to 1.5-High and Two-High low storage and laterals. If no top is selected, low storage and laterals accommodate attachment to a worksurface or common top. Attachment hardware is included.

**Drawer and door fronts** are available in Low-Pressure Laminate are full to the bottom of the case (no toe kick).

**Finished back and sides** are standard on low storage and lateral files.

**File drawers** open their full depth for total access to the contents and have an integrated U-channel on the drawer bodies for hanging file folder frames.

**Adjustable shelf thickness** is <sup>3</sup>/<sub>4</sub>".



**Pull on low storage with doors and laterals** is available in a ledge style only.

**Standard lock cylinders and keys** are included with Embank low storage with doors and lateral files. Lock is located on the top left corner of the right handed door of lower storage with doors. Lock is located in the bottom drawer of lateral files, and locks the drawer it is located in and the one above. Locks secure all drawers. If a master key is optioned, **AMQLOCK9201XF** must be specified to be included. All lock cylinders are field-installed.

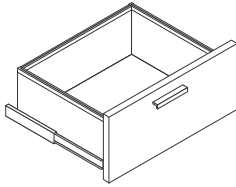
**Leveling glides** adjust to install low storage and laterals on uneven floors and have a 1<sup>1</sup>/<sub>4</sub>" adjustable glide range.

Actual Dimensions			
	One-High File	1.5-High Box/File and Open/File	Two-High Cabinet
Depth	24"	24"	24"
Width	30" and 36"	30" and 36"	30" and 36"
Height	15 <sup>3</sup> / <sub>8</sub> "	21 <sup>3</sup> / <sub>8</sub> "	27 <sup>5</sup> / <sub>16</sub> "
	One-High Open Low Storage	1.5-High Open Low Storage	Two-High Open Low Storage
Depth	24"	24"	24"
Width	30" and 36"	30" and 36"	30" and 36"
Height	15 <sup>3</sup> / <sub>8</sub> "	21 <sup>3</sup> / <sub>8</sub> "	27 <sup>5</sup> / <sub>16</sub> "

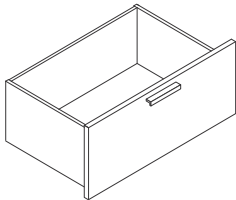
\* The top (if specified) matches the depth of units with drawers and doors.  
 Tip: All heights are without top. Add 1<sup>1</sup>/<sub>8</sub>" to achieve overall height with top.

## Product Details

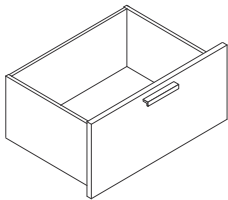
**Drawers** are black, bore and dowel construction.



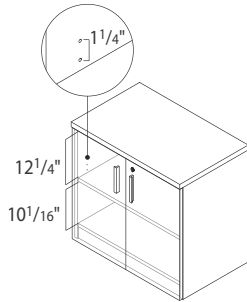
**File drawer body** is standard with integrated U-channel to accommodate hanging folder files.



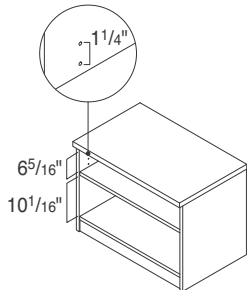
**36" W file drawers** accommodate front-to-back and side-to-side letter filing, as well as front-to-back legal filing. 24"D file drawers also accommodate side-to-side legal filing.



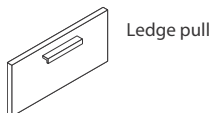
**30" W file drawers** accommodate front-to-back and side-to-side letter filing, as well as front-to-back legal filing. 24"D file drawers also accommodate side-to-side legal filing.



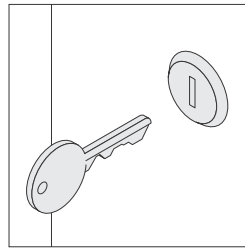
**Two-High lower storage** has three holes for adjustable shelf placement, spaced 1<sup>1</sup>/<sub>4</sub>" apart. When the adjustable shelf is in the bottom position, the top shelf has 12<sup>1</sup>/<sub>4</sub>" of usable space, and the bottom shelf has 10<sup>1</sup>/<sub>16</sub>" of usable space.



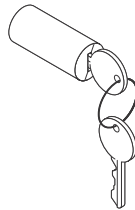
**1.5-High lower storage** has three holes for adjustable shelf placement, spaced 1<sup>1</sup>/<sub>4</sub>" apart. When the adjustable shelf is in the bottom position, the top shelf has 6<sup>5</sup>/<sub>16</sub>" of usable space, and the bottom shelf has 10<sup>1</sup>/<sub>16</sub>" of usable space.



**Pulls** are available in a ledge style only.



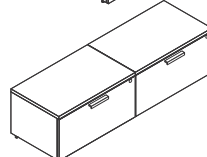
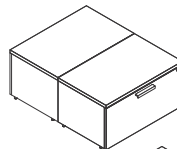
**Locks** are field-installed. Low storage with doors and lateral files are shipped installed with plugs with the lock cylinders separate.



► Lock and Keying, page 380

**Counterweight packages** are included and required to ensure product stability.

**One fixed shelf** is included in 1.5-High and Two-High open and hinged door configurations.



**Ganging hardware** is available to provide alignment by joining adjacent components side-by-side, back-to-back, or both.

**Side-by-side units with individual tops** will result in a nominal <sup>3</sup>/<sub>32</sub>" gap.

## Surface Materials

**EMBANK storage** can be specified with different case, headset, and top laminate finishes.

### Low storage or lateral file case, headsets, and top

- 24L0 Graphite Walnut
- 25L5 Virginia Walnut
- 25L8 Clear Walnut
- 26L1 Natural Cherry
- 2L09 Clear Maple
- 2L30 Arctic White
- 2L83 Seagull
- 2L84 Milk
- 2LAK Clear Oak
- 2LAT Acacia
- 2LAW Ash Wenge
- 2LCN Clay Noce
- 2LCW Clay Wenge

### Ledge pull

- 4799 Platinum Metallic
- 7207 Black

### Lock

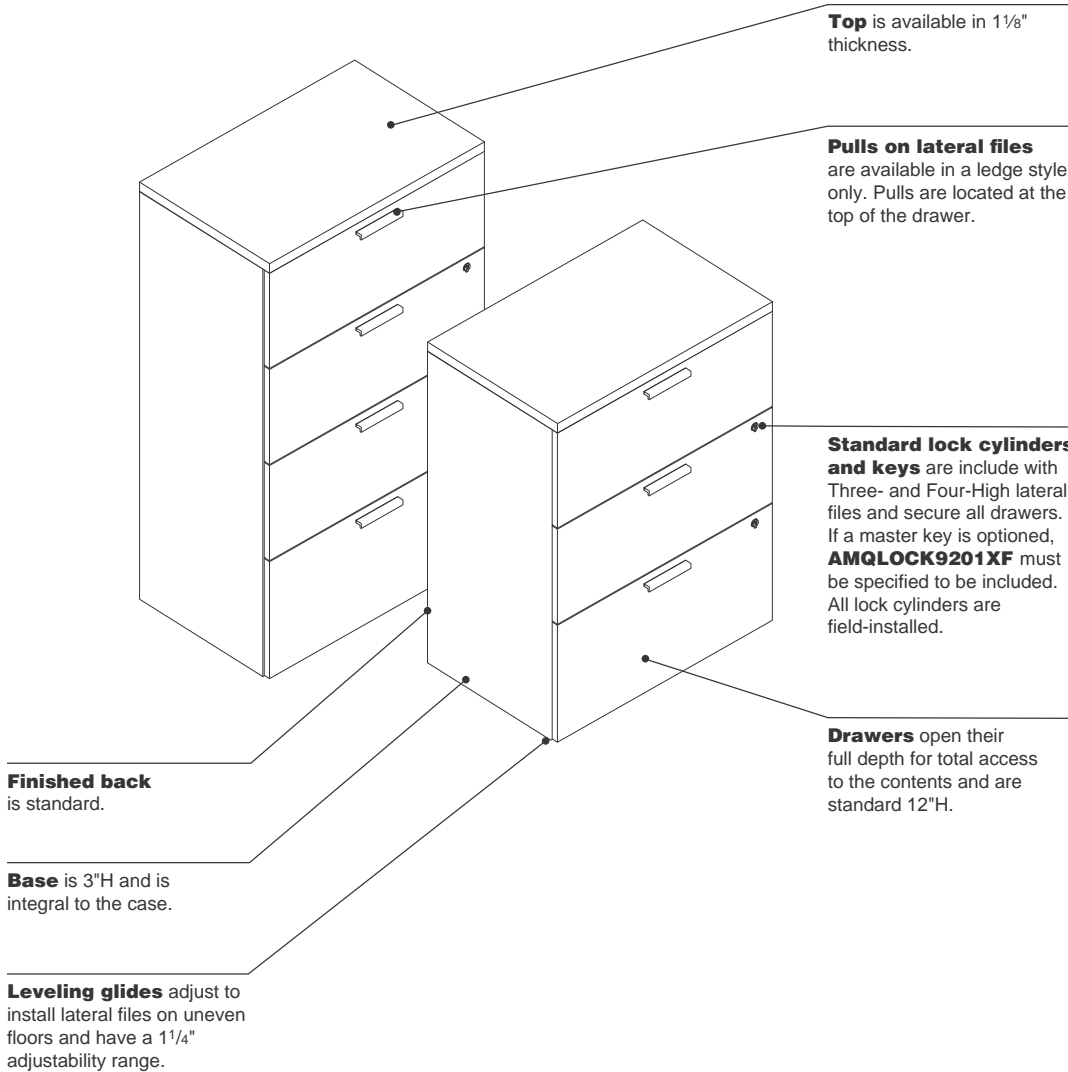
- 9201 Polished Chrome

### Drawer bodies, drawer suspensions, and glides

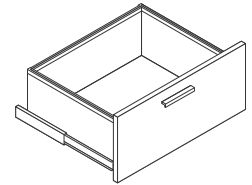
- Black

# EMBANK Three-High and Four-High Lateral Files

**Lateral files** are ideal for high-density paper storage.

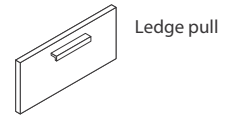


## Product Details

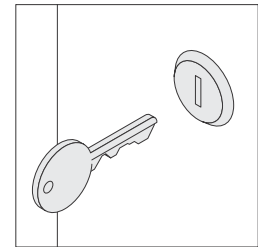


**File drawer body** is standard with integral top rail to accommodate hanging folder files. Drawers are a black bore and dowel construction with a proud front.

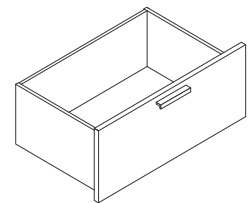
**Safety interlock system** allows only one drawer or roll-out shelf to be opened at a time.



**Pulls** are available in a ledge style only.



**Locks** are field-installed. Lateral files are shipped installed with plugs, with lock cylinders separate.

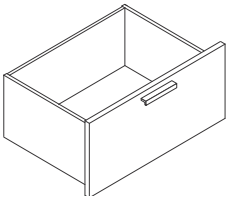


**36"W file drawers** accommodate front-to-back and side-to-side letter filing, as well as front-to-back legal filing.

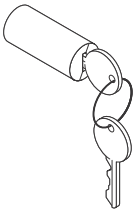
## Actual Dimensions

	Three-High	Four-High
Depth	18 7/8"	18 7/8"
Width	30" and 36"	30" and 36"
Height	40 1/3"	52 1/3"

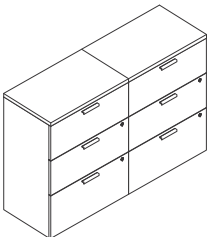
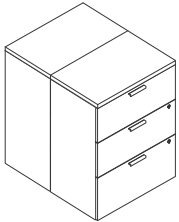
*Tip: Heights shown are with a top.*



**30"W file drawers** accommodate front-to-back and side-to-side letter filing, as well as front-to-back legal filing.



► *Lock and Keying*, page 381



**Ganging hardware** is available to provide alignment by joining adjacent components side-by-side, back-to-back, or both.

**Counterweight packages** are included and required to ensure product stability.

### Surface Materials

**EMBANK lateral files** can be specified with different case, headset, and top laminate finishes.

#### Lateral file case, headsets, and top

- 24L0 Graphite Walnut
- 25L5 Virginia Walnut
- 25L8 Clear Walnut
- 26L1 Natural Cherry
- 2L09 Clear Maple
- 2L30 Arctic White
- 2L83 Seagull
- 2L84 Milk
- 2LAK Clear Oak
- 2LAT Acacia
- 2LAW Ash Wenge
- 2LCN Clay Noce
- 2LCW Clay Wenge

#### Ledge pull

- 4799 Platinum Metallic
- 7207 Black

#### Lock

- 9201 Polished Chrome

#### Drawer bodies, drawer suspensions, and glides

- Black

### Application Topics

#### Storage Capacities and Dimensions

► Page 334

# EMBANK Credenzas

**Credenzas** come in various depths, heights, and storage configurations.

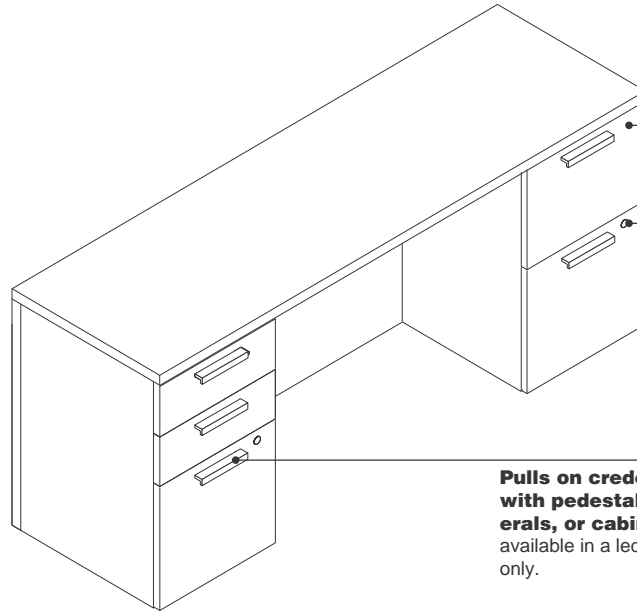
**Full storage credenzas** are available in 24"D and a two-high height.

**Top** are available in a 1½" thicknesses.

**Finished back** is included on all full storage credenzas.

**Credenzas with kneespace** are available in 24"D, and single or double pedestal configurations.

**Modesty panels** are available on credenzas with kneespace in either full height or ¼-height.

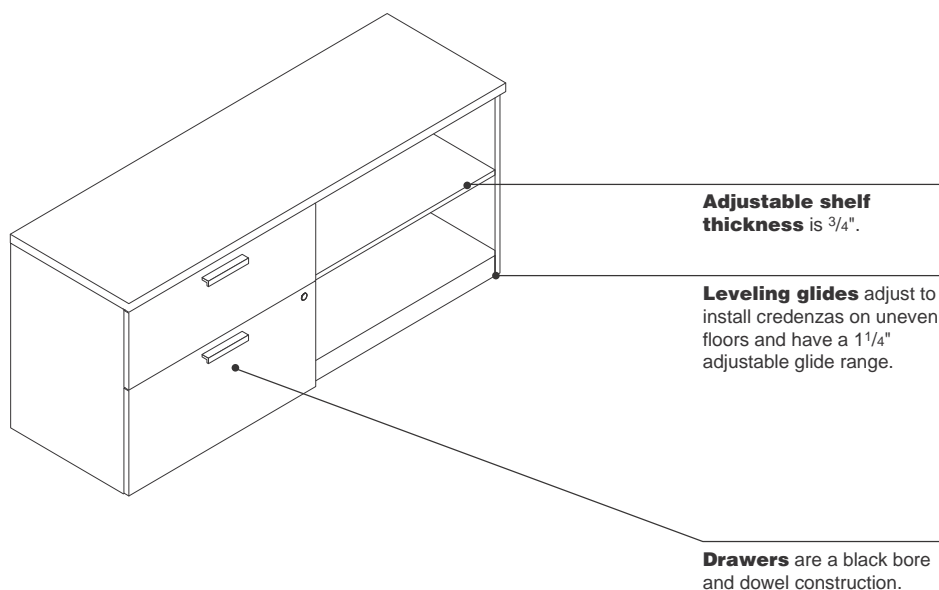


**Drawers** are black bore and dowel construction.

**Standard lock cylinders and keys** are included with Embank credenzas with pedestals, laterals, or cabinets. Lock is located in either the bottom drawer, and locks the drawer it is located in and the one above, or the right-handed door. Lock cylinders are standard and are field-installed. If a master key is optioned, **AMQLOCK9201XF** must be specified to be included. All lock cylinders are field-installed.

► Lock and Keying, page 380

**Pulls on credenzas with pedestals, laterals, or cabinets** are available in a ledge style only.



**Actual Dimensions**

**Full Storage Credenzas**

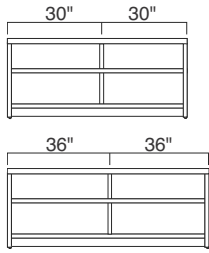
	<b>Open/Open</b>	<b>Open/ Lateral File</b>	<b>Lateral File/ Lateral File</b>	<b>Lateral File/ Cabinet</b>	<b>Cabinet/ Cabinet</b>
Depth	24"	24"	24"	24"	24"
Width	60", 66", and 72"	60", 66", and 72"	60", 66", and 72"	60", 66", and 72"	60", 66", and 72"
Height	$27\frac{5}{16}$ "	$27\frac{5}{16}$ "	$27\frac{5}{16}$ "	$27\frac{5}{16}$ "	$27\frac{5}{16}$ "

**Credenzas with Kneespace**

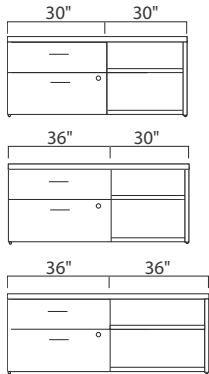
	<b>Single Pedestal</b>	<b>Double Pedestal</b>
Depth	24"	24"
Width	66" and 72"	66" and 72"
Height	$28\frac{7}{16}$ "	$28\frac{7}{16}$ "

*Tip: Credenzas with kneespace are standard with a  $1\frac{1}{8}$ "-thick top, included in the overall height.*

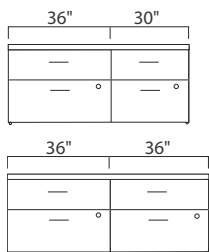
**Product Details**



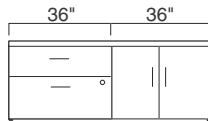
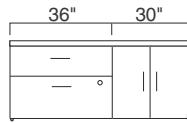
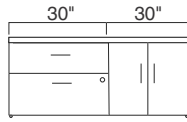
**Open/open credenzas** are divided evenly with a single center support in all widths.



**Open/lateral file credenzas in 60"W** include 30"W file drawers. 66"W and 72"W open/lateral file credenzas include 36"W file drawers.

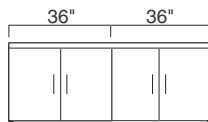
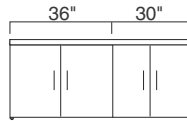
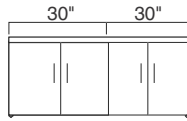


**Lateral file/lateral file credenzas in 60"W** include 30"W file drawers. 66"W lateral file/lateral file credenzas include 36"W (left) and 30"W (right) file drawers. 72"W lateral file/lateral file credenzas include 36"W file drawers.

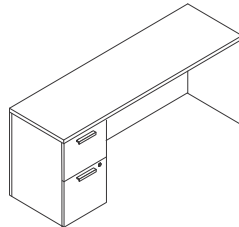
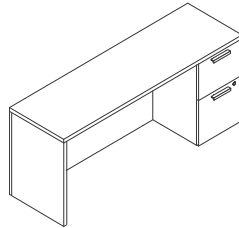
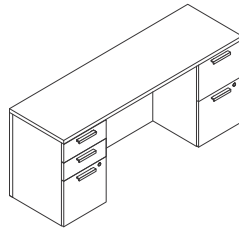


**Lateral file/cabinet credenzas in 60"W** include 30"W file drawers. 66"W and 72"W lateral file/cabinet credenzas include 36"W file drawers.

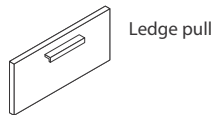
*Tip: "Handedness" option of lateral file/open or lateral file/cabinet credenzas determine the location of the lateral file.*



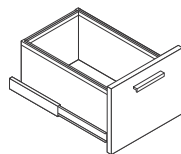
**Cabinet/cabinet credenzas** are divided evenly with a double center support in 60"W, 66"W, and 72"W cases. All widths include four doors.



**Credenzas with kneespace** are available in 66"W and 72"W include either a left, right, or double pedestal configuration.



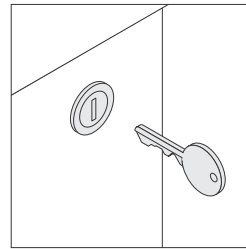
**Pulls** are available in a ledge style only.



**File drawer body** is standard with integrated U-channel to accommodate hanging folder files.

**Modesty panels and back panels** have horizontal grain direction.

**End panels** have vertical grain direction.



**Locks** cylinders are standard and are field-installed. ▶ Lock and Keying, page 380

**Counterweight pack-ages** are required to ensure product stability and are included in credenzas.

**Storage capacities and dimensions**  
▶ See page 334

**Surface Materials**

**EMBANK credenzas** can be specified with different case, headset, and top laminate finishes.

**Credenza case, headsets, and top**

- 24L0 Graphite Walnut
- 25L5 Virginia Walnut
- 25L8 Clear Walnut
- 26L1 Natural Cherry
- 2L09 Clear Maple
- 2L30 Arctic White
- 2L83 Seagull
- 2L84 Milk
- 2LAK Clear Oak
- 2LAT Acacia
- 2LAW Ash Wenge
- 2LCN Clay Noce
- 2LCW Clay Wenge

**Ledge pull**

- 4799 Platinum Metallic
- 7207 Black

**Lock**

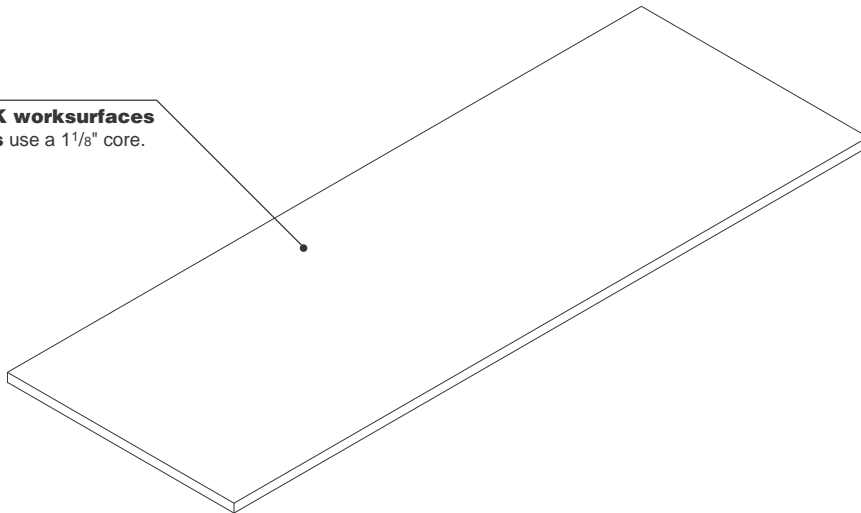
- 9201 Polished Chrome

**Drawer bodies, drawer suspensions, and glides**

- Black

**EMBANK common top** is used to create storage applications with a seamless top, or as a table or desk with legs.

**EMBANK worksurfaces and tops** use a 1<sup>1</sup>/<sub>8</sub>" core.



## Actual Dimensions

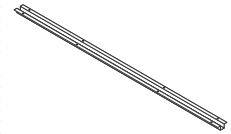
EMBANK Common Top	
Depth	18 <sup>7</sup> / <sub>8</sub> ", 24", and 30"
Width	45 <sup>11</sup> / <sub>16</sub> ", 51 <sup>11</sup> / <sub>16</sub> ", 59 <sup>3</sup> / <sub>4</sub> ", 65 <sup>3</sup> / <sub>4</sub> ", 71 <sup>3</sup> / <sub>4</sub> ", 89 <sup>9</sup> / <sub>16</sub> ", 89 <sup>13</sup> / <sub>16</sub> ", and 95 <sup>13</sup> / <sub>16</sub> "
Worksurface/ Top Thickness – 1 <sup>1</sup> / <sub>8</sub> " core	1 <sup>1</sup> / <sub>8</sub> "

## Product Details

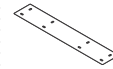
**Common tops** are available in Low-Pressure Laminate.

**Common tops** are standard 1<sup>1</sup>/<sub>8</sub>" thick.

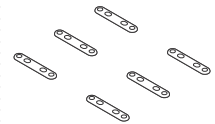
**Common tops** have 3 mm plastic edge banding on the front (user's) side. Sides and back have matching 1 mm edge.



**Reinforcing channels** must be used with tops larger than 54"W for 54"W or more of unsupported kneespace. Any common top used as a table with legs equal to or larger than 30"D x 72"W requires two reinforcing channels.



**Support plates** are available to connect two worksurfaces and allow one to support the other.



**Tie plates** are available to provide added strength and alignment between two worksurfaces.

## Surface Materials

- Top**
- 24L0 Graphite Walnut
  - 25L5 Virginia Walnut
  - 25L8 Clear Walnut
  - 26L1 Natural Cherry
  - 2L09 Clear Maple
  - 2L30 Arctic White
  - 2L83 Seagull
  - 2L84 Milk
  - 2LAK Clear Oak
  - 2LAT Acacia
  - 2LAW Ash Wenge
  - 2LCN Clay Noce
  - 2LCW Clay Wenge

- Edge**
- Plastic

# EMBANK Desks, Desk Shells, Returns, Return Shells, and Bridges

**Desks** are freestanding and are available with and without pedestals, to create a desk shell, single pedestal desk, or double pedestal desk.

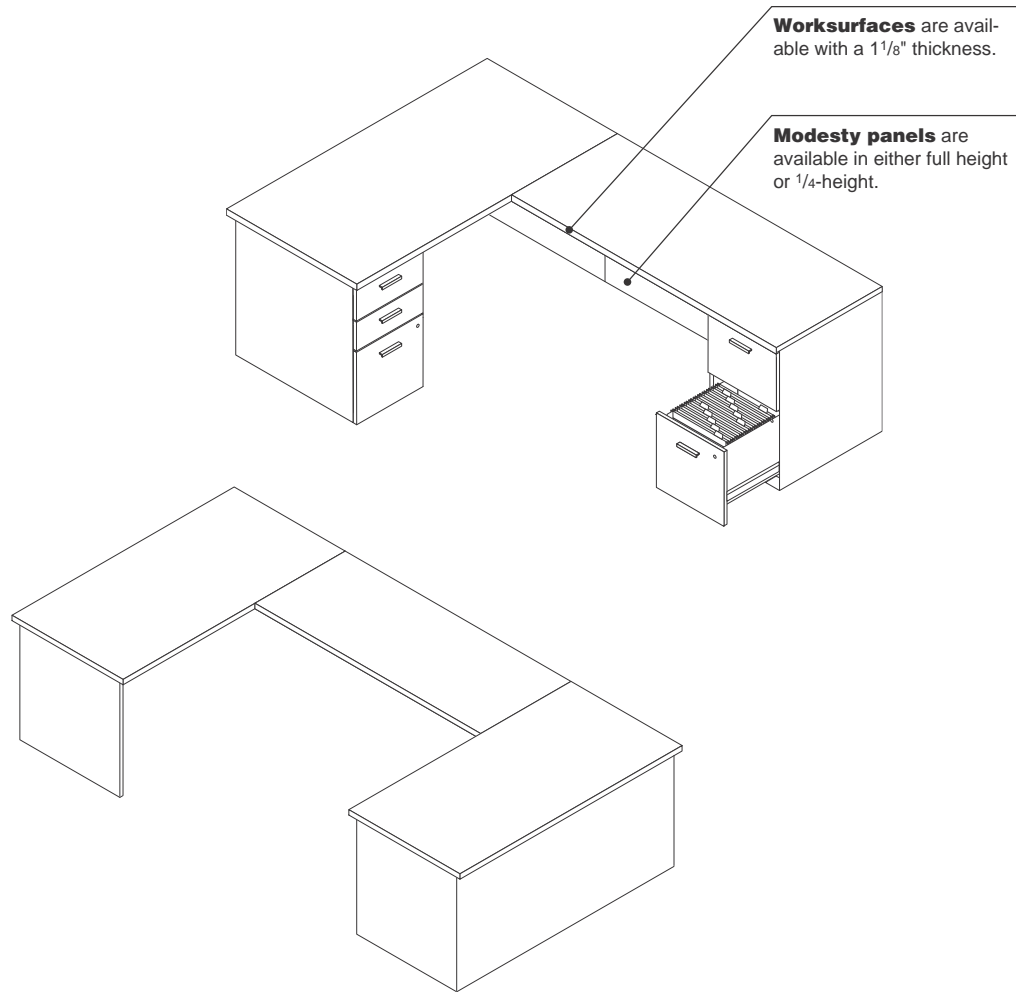
► Specifying, page 354

**Returns** are available with and without pedestals, to create a single pedestal return or return shell. Returns attach to desks or credenzas to form an L-shape configuration. Attachment brackets are included with returns.

► Specifying, page 356

**Bridges** must attach to a worksurface on each side to create a U-shape configuration. Attachment brackets are included with bridges.

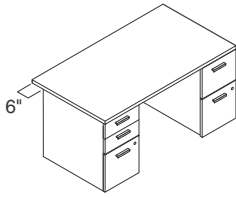
► Specifying, page 357



Actual Dimensions					
	Desks (with pedestal)	Desk Shells	Returns	Return Shells	Bridges
Depth	30" and 36"	24", 30", and 36"	24"	24"	24"
Width	60"–72"	60"–72"	42" or 48"	42" or 48"	36", 42", and 48"
Height	28 <sup>7</sup> / <sub>16</sub> "	28 <sup>7</sup> / <sub>16</sub> "	28 <sup>7</sup> / <sub>16</sub> "	28 <sup>7</sup> / <sub>16</sub> "	28 <sup>7</sup> / <sub>16</sub> "

*Tip: Height shown is with a 1 1/8" top specification.  
\*Not all widths are available with all depths. See specification pages.*

**Product Details**



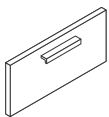
**36"D desks** have a 6" overhang on the visitor side. End panels/pedestals will be 30"D.

**Standard lock cylinders and keys** are included with Embank desks and returns with pedestals. Lock is located in the bottom drawer, and locks the drawer it is located in, and the one above. If a master key is optioned, **AMQLOCK9201XF** must be specified to be included. All lock cylinders are field-installed.

**Leveling glides** adjust to install desks and returns on uneven floors and have a 1¼" adjustable glide range.

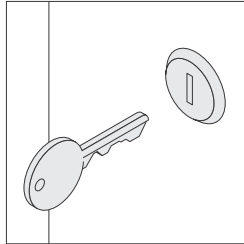
**Modesty panels** have horizontal grain direction.

**End panels** have vertical grain direction.



Ledge pull

**Pulls** are available in a ledge style only.



**Locks** are standard on desks and returns with storage. Lock cylinders are standard and are field-installed. ▶ Lock and Keying, page 380

**Counterweight packages** are included and required to ensure product stability.

**Back and end panel configurations** differ depending on the modesty panel and support options selected.

**Surface Materials**

**EMBANK desks, returns, and bridges** can be specified with different case, headset, and top laminate finishes.

**Desk, return, and bridge case, headsets, and top**

- 24L0 Graphite Walnut
- 25L5 Virginia Walnut
- 25L8 Clear Walnut
- 26L1 Natural Cherry
- 2L09 Clear Maple
- 2L30 Arctic White
- 2L83 Seagull
- 2L84 Milk
- 2LAK Clear Oak
- 2LAT Acacia
- 2LAW Ash Wenge
- 2LCN Clay Noce
- 2LCW Clay Wenge

**Ledge pull**

- 4799 Platinum Metallic
- 7207 Black

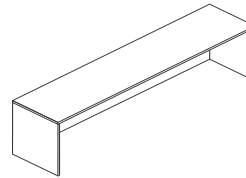
**Lock**

- 9201 Polished Chrome

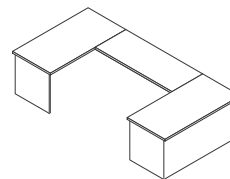
**Drawer bodies, drawer suspensions, and glides**

- Black

**Application Topics**



**60"W or wider desk shells** require a reinforcing channel, due to unsupported knee space 54" or greater. 72"W or greater desks receive a center support.



**If a bridge is specified in a U-shaped configuration**, a reinforcing channel must be used with 54"W or more of unsupported knee space.

**When specifying a reinforcing channel**, use the largest available size that fits within the open kneespace.

**Storage capacities and dimensions**

▶ Page 334

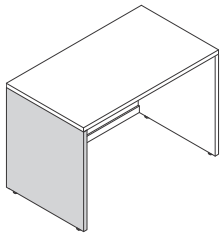
**Attaching** monitor arms to a return is not a valid application.

**Back and end panel configurations** vary depending on the modesty panel and storage options selected.

**Desks**

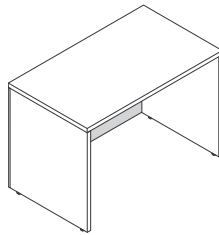
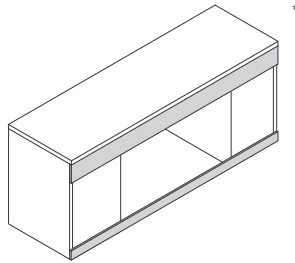
**End Panel Over Back Panel**

- Desks with 1/4-height modesty panel + two end panels.



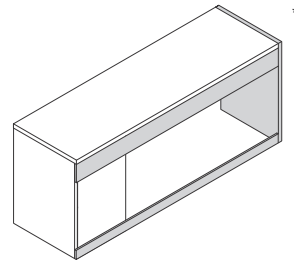
**Back Panel Over End Panel**

- Desks with 1/4-height modesty panel + two pedestals
- Desks with full modesty panel



**Mix**

- Desks with 1/4-height modesty panel + one pedestal + end panel

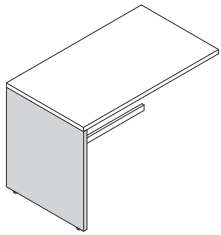


*Tip: When 1/4-height modesty is selected for desks, top and bottom rails are included.*

**Returns**

**End Panel Over Back Panel**

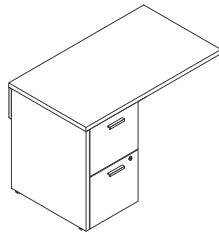
- Returns with 1/4-height modesty panel + end panel



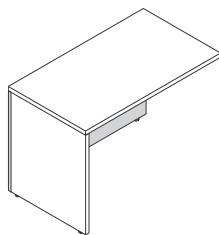
*Tip: When 1/4-height modesty on a return with no pedestal is selected, top and bottom rails are included.*

**Back Panel Over End Panel**

- Returns with 1/4-height modesty panel + pedestal
- Returns with full modesty panel



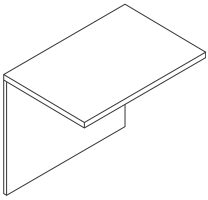
*Tip: When 1/4-height modesty is selected for a return + pedestal configuration, only a top rail is included.*



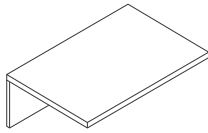
\*Back of desk shown

**Bridges**

**Full Modesty**



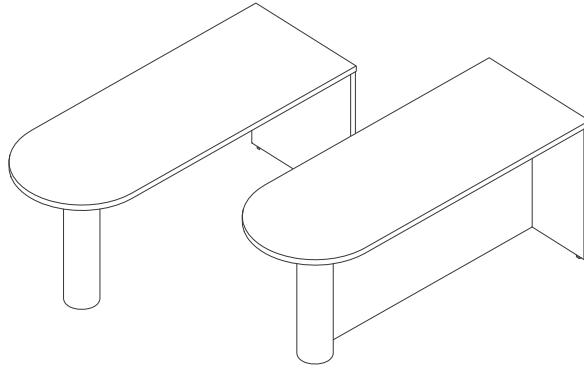
**Quarter Modesty**



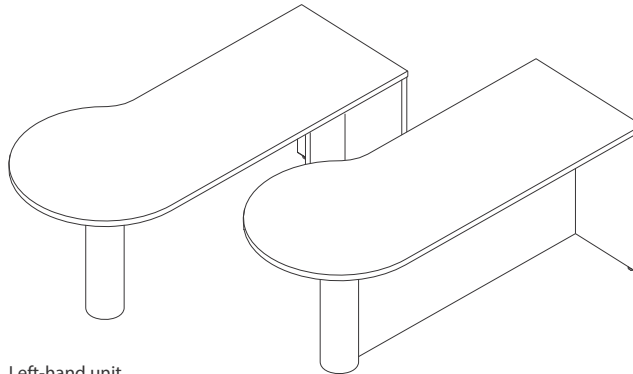
# EMBANK D-Shape and P-Shape Worksurfaces

**EMBANK D- and P-shape worksurfaces** offer unique support for meetings.

**D-Shape**



**P-Shape**



Left-hand unit

## Product Details

**D- and P-shape worksurfaces** must be attached to a bridge, return, or adjoining worksurface to form a flush-height, L- or U-shaped configuration and to provide stability. Right-hand P-shape worksurfaces pair with left-hand returns. Left-hand P-shape worksurfaces pair with right-hand returns.

**D- and P-shape worksurfaces** include an end panel, and are available with and without modesty panels.

**Modesty panels** are available in either full height or 1/4-height. Full-height modesty panels go to the floor. The 1/4-height modesty panels suspend from worksurface, and are 13<sup>3</sup>/<sub>4</sub>" high.

**Column leg diameter** is 6".

## Surface Materials

### Case (end and modesty panel) and top

- 24L0 Graphite Walnut
- 25L5 Virginia Walnut
- 25L8 Clear Walnut
- 26L1 Natural Cherry
- 2L09 Clear Maple
- 2L30 Arctic White
- 2L83 Seagull
- 2L84 Milk
- 2LAK Clear Oak
- 2LAT Acacia
- 2LAW Ash Wenge
- 2LCN Clay Noce
- 2LCW Clay Wenge

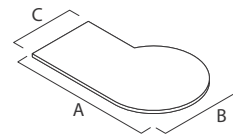
### Column leg

- 4799 Platinum Metallic
- 7207 Black

## Actual Dimensions

### EMBANK D-Shape and P-Shape Worksurface Modular Sizes

D-Shape Worksurfaces	
<b>Depth</b>	30", 36"
<b>Width</b>	60", 66", 72"
P-Shape Worksurfaces	
<b>Depth B Range</b>	30", 36", 42"
<b>Depth C Range</b>	24", 30", 36"
<b>Width A Range</b>	60", 66", 72"



Right-hand unit



# EMBANK Towers and Wardrobes

## Towers and wardrobes

provide storage for a variety of work and personal items including: paper, binders, books, and coats.

**Towers** are available in a variety of box and file drawer configurations.

**Locker space** is 8" wide and standard with a coat hook on the hinge side of the door.

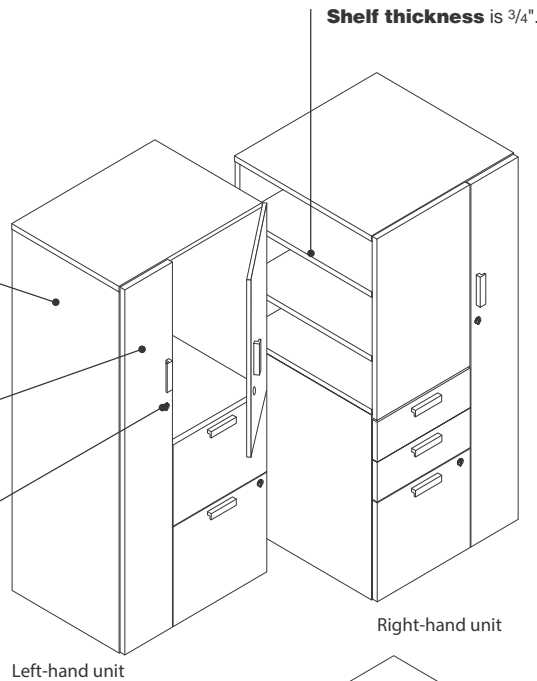
**Locks** are standard on door and drawers. Lock cylinders are standard and are field-installed.

▶ Lock and Keying, page 380

**Finished back** is standard.

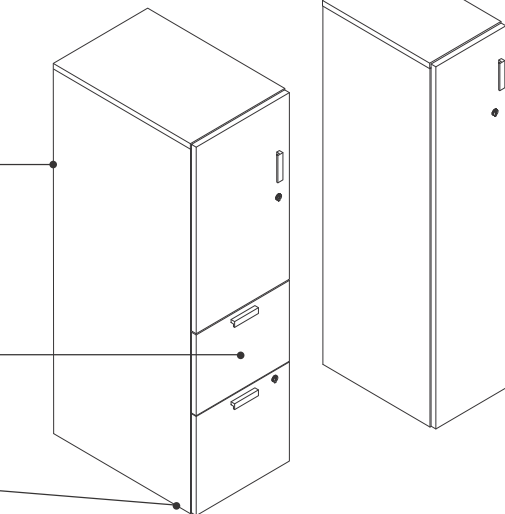
**Drawers** open their full depth for total access to the contents.

**Leveling glides** adjust to install tower and wardrobe on uneven floors and have a 1<sup>1</sup>/<sub>4</sub>" adjustable range.



Left-hand unit

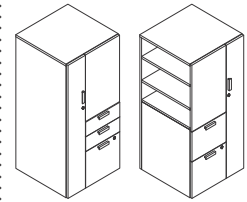
Right-hand unit



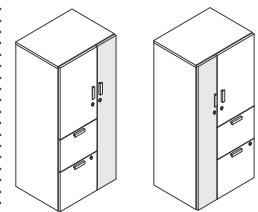
## Actual Dimensions

	Single Door with Drawers	Dual Door with Drawers	Side Access Tower with Drawers	Single Door Wardrobe
Depth	24"	24"	24"	24"
Width	15 <sup>29</sup> / <sub>32</sub> "	24"	24"	12"
Height	41 <sup>25</sup> / <sub>32</sub> ", 47 <sup>31</sup> / <sub>32</sub> ", 54 <sup>1</sup> / <sub>8</sub> ", and 66 <sup>1</sup> / <sub>2</sub> "	41 <sup>25</sup> / <sub>32</sub> ", 47 <sup>31</sup> / <sub>32</sub> ", 54 <sup>1</sup> / <sub>8</sub> ", and 66 <sup>1</sup> / <sub>2</sub> "	41 <sup>25</sup> / <sub>32</sub> ", 47 <sup>31</sup> / <sub>32</sub> ", 54 <sup>1</sup> / <sub>8</sub> ", and 66 <sup>1</sup> / <sub>2</sub> "	41 <sup>25</sup> / <sub>32</sub> ", 47 <sup>31</sup> / <sub>32</sub> ", and 54 <sup>1</sup> / <sub>8</sub> "

## Product Details



**Tower and wardrobe** combines coat storage, box and file drawers, and shelves.

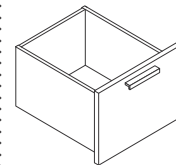


Door hinged on left

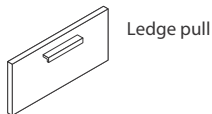
Door hinged on right

**Door on wardrobe** is full height and can be hinged on the left or right. Coat hook is always located on the same side as the door hinge.

**Box drawers** are a black, bore and dowel construction.

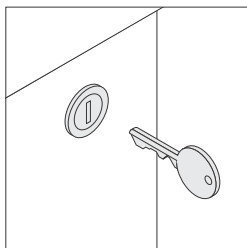


**File drawer body** is standard with integral top rail to accommodate hanging file folders.



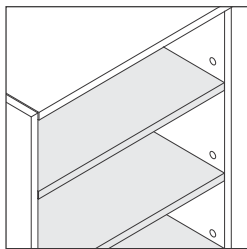
Ledge pull

**Pulls** are available in a ledge style only.



**Standard lock cylinders and keys** are included with Embank towers and wardrobes. If a master key is optioned, **AMQLOCK9201XF** must be specified to be included. All lock cylinders are field-installed.

▶ Lock and Keying, page 380



**Adjustable shelves on 54<sup>1</sup>/<sub>8</sub>"H and 66<sup>1</sup>/<sub>2</sub>"H side access towers** are recessed from the side of the tower.

**AMQCRTWSABBFL, AMQCRTWSABBFR, AMQCRTWSAFFL, and AMQCRTWSAFFR:**

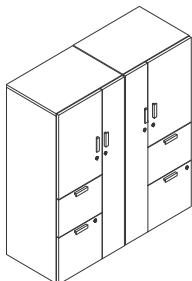
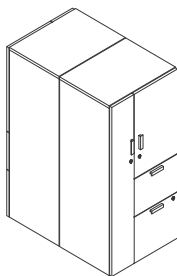
- **41<sup>25</sup>/<sub>32</sub>"H and 47<sup>31</sup>/<sub>32</sub>"H towers** have one bottom fixed shelf.
- **54<sup>1</sup>/<sub>8</sub>"H towers** have one bottom fixed shelf and one adjustable shelf.
- **66<sup>1</sup>/<sub>2</sub>"H towers** have one bottom fixed shelf and two adjustable shelves.

**AMQCRTWBFL, AMQCRTWBFR, AMQCRTWFFL, AMQCRTWFFR, AMQCRTWDBFL, AMQCRTWDBFR, AMQCRTWDFFL, and AMQCRTWDFFR, Box/ File configuration:**

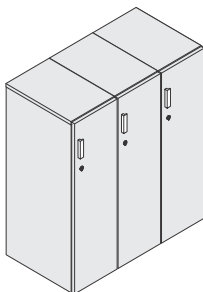
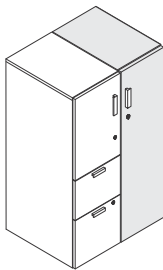
- **41<sup>25</sup>/<sub>32</sub>"H towers** have one bottom fixed shelf.
- **47<sup>31</sup>/<sub>32</sub>"H and 54<sup>1</sup>/<sub>8</sub>"H towers** have one bottom fixed shelf and one adjustable shelf.
- **66<sup>1</sup>/<sub>2</sub>"H towers** have one bottom fixed shelf and two adjustable shelves.

**AMQCRTWBFL, AMQCRTWBFR, AMQCRTWFFL, AMQCRTWFFR, AMQCRTWDBFL, AMQCRTWDBFR, AMQCRTWDFFL, and AMQCRTWDFFR, File/ File configuration:**

- **41<sup>25</sup>/<sub>32</sub>"H and 47<sup>31</sup>/<sub>32</sub>"H towers** have one bottom fixed shelf.
- **54<sup>1</sup>/<sub>8</sub>"H towers** have one bottom fixed shelf and one adjustable shelf.
- **66<sup>1</sup>/<sub>2</sub>"H towers** have one bottom fixed shelf and two adjustable shelves.

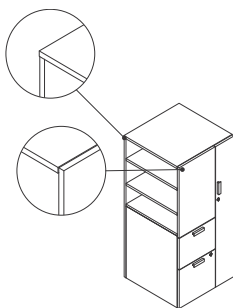


**Ganging hardware** is available to provide alignment by joining adjacent storage components side-by-side, back-to-back, or both.



**Wardrobes** must be attached to two additional wardrobes, another storage unit, or a wall to ensure stability and prevent wardrobe from tipping over. Contact [orders@amqsolutions.com](mailto:orders@amqsolutions.com) to order service parts for special connections.

**Counterweight packages** are included and required to ensure product stability.



**Side access tower construction** is as follows:

- Front panel over top panel
- Top panel over back panel

## Surface Materials

**EMBANK storage** can be specified with different case and headset laminate finishes.

**Tower door fronts and front panels** will not have matching grain direction with drawer fronts.

### Low storage or lateral file case and headsets

- 24L0 Graphite Walnut
- 25L5 Virginia Walnut
- 25L8 Clear Walnut
- 26L1 Natural Cherry
- 2L09 Clear Maple
- 2L30 Arctic White
- 2L83 Seagull
- 2L84 Milk
- 2LAK Clear Oak
- 2LAT Acacia
- 2LAW Ash Wenge
- 2LCN Clay Noce
- 2LCW Clay Wenge

### Ledge pull

- 4799 Platinum Metallic
- 7207 Black

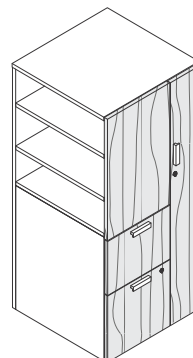
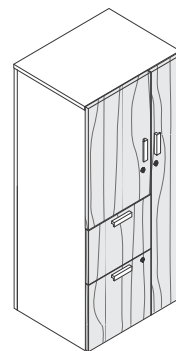
### Lock

- 9201 Polished Chrome

### Drawer bodies, drawer suspensions, and glides

- Black

## Grain Direction



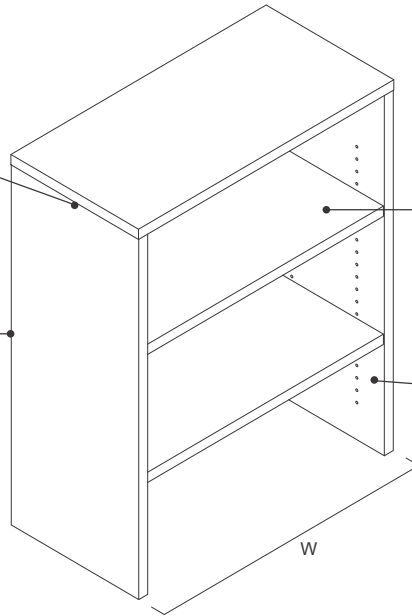
*Tip: Tower door fronts will not have matching grain direction with drawer fronts.*

# EMBANK Bookcases

**Bookcases** offer convenient storage for binders, books, and other objects.

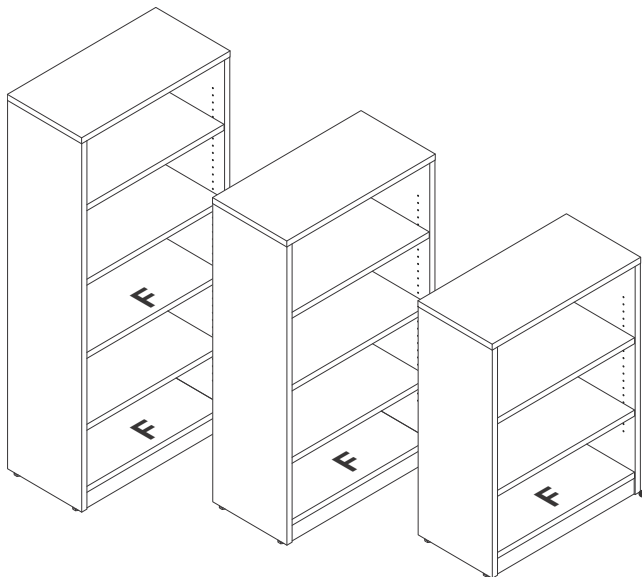
**Top** is standard 1"H laminate.

**Finished back** is standard.



**Shelves** adjust in 1 1/4" vertical increments using a reversible bracket.

**Shelf thickness** is 3/4".



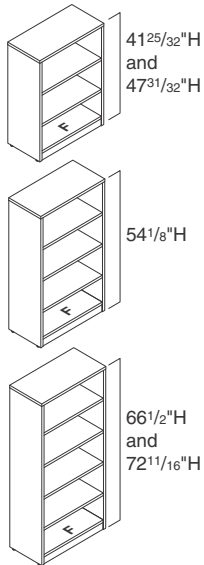
**Leveling glides** adjust up to 1 1/4" to install bookcase on uneven floors.

## Actual Dimensions

	Bookcase	Stacking Bookcase
Depth	15"	15"
Width	30" and 36"	30" and 36"
Height	41 <sup>25</sup> / <sub>32</sub> ", 47 <sup>31</sup> / <sub>32</sub> ", 54 <sup>1</sup> / <sub>8</sub> ", 66 <sup>1</sup> / <sub>2</sub> ", and 72 <sup>11</sup> / <sub>16</sub> "	25 <sup>5</sup> / <sub>8</sub> ", 37 <sup>31</sup> / <sub>32</sub> ", and 44 <sup>3</sup> / <sub>16</sub> "

**Product Details**

**Bookcases** are available with adjustable shelves. Shelves can be repositioned without using tools.

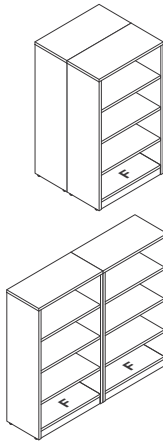


**The number of adjustable shelves per bookcase** depends on case height:

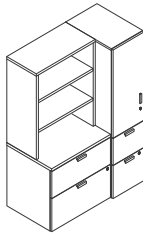
- 41<sup>25</sup>/<sub>32</sub>"H—2 adjustable shelves
- 47<sup>31</sup>/<sub>32</sub>"H—2 adjustable shelves
- 54<sup>1</sup>/<sub>8</sub>"H—3 adjustable shelves
- 66<sup>1</sup>/<sub>2</sub>"H—4 adjustable shelves
- 72<sup>11</sup>/<sub>16</sub>"H—4 adjustable shelves

**25<sup>5</sup>/<sub>8</sub>"H stacking bookcases** include adjustable shelf. All other heights include two adjustable shelves.

**Standard-size binders** will fit in bookcases with adjustable shelves.



**Ganging hardware** is available to provide alignment by joining adjacent components side-by-side, back-to-back, or both. EMBANK bookcases 66<sup>1</sup>/<sub>2</sub>"H and larger must be placed against a wall, if not ganged back-to-back.



**Stacking bookcases** are designed to align with other EMBANK tall storage. 25<sup>5</sup>/<sub>8</sub>"H stacking bookcases align with 54<sup>1</sup>/<sub>8</sub>"H tall storage. 37<sup>3</sup>/<sub>16</sub>"H stacking bookcases align with 66<sup>1</sup>/<sub>2</sub>"H tall storage. 44<sup>3</sup>/<sub>16</sub>"H stacking bookcases align with 72<sup>11</sup>/<sub>16</sub>"H tall storage.

**When specifying stacking bookcases,** selecting the correct worksurface thickness of the application ensures that the stacking bookcase aligns with other tall storage.

**Stacking bookcases** must be used with One-High, 1.5-High, or Two-High laterals or lower storage. Stacking bookcases cannot be freestanding.

**Surface Materials**

**Bookcase case**

- 24L0 Graphite Walnut
- 25L5 Virginia Walnut
- 25L8 Clear Walnut
- 26L1 Natural Cherry
- 2L09 Clear Maple
- 2L30 Arctic White
- 2L83 Seagull
- 2L84 Milk
- 2LAK Clear Oak
- 2LAT Acacia
- 2LAW Ash Wenge
- 2LCN Clay Noce
- 2LCW Clay Wenge

**Adjustable shelf brackets**

- Brushed nickel

**Application Topics**

**Storage Capacities and Dimensions**

▶ Page 334

**66<sup>1</sup>/<sub>2</sub>"H and 72<sup>11</sup>/<sub>16</sub>"H freestanding bookcases** need to be placed back-to-back or against the wall.

**Stacking bookcases** can be shorter than the supporting worksurface as long as a worksurface support or side panel of a storage unit is used under the worksurface within 6" of where the side of the stacking bookcase is loaded.

# EMBANK Overheads and Organizers

**EMBANK overheads and organizers** provide storage above a workspace and can be used in a variety of applications.

**Sliding door overheads** have a non-locking sliding door. Door is available in Low-Pressure Laminate, and optional markerboard surface.  
*Tip: Markerboard is slightly thicker than the standard laminate.*

**Hinged door overheads** have two, three, or four locking doors depending on width. Doors are available in Low-Pressure Laminate.

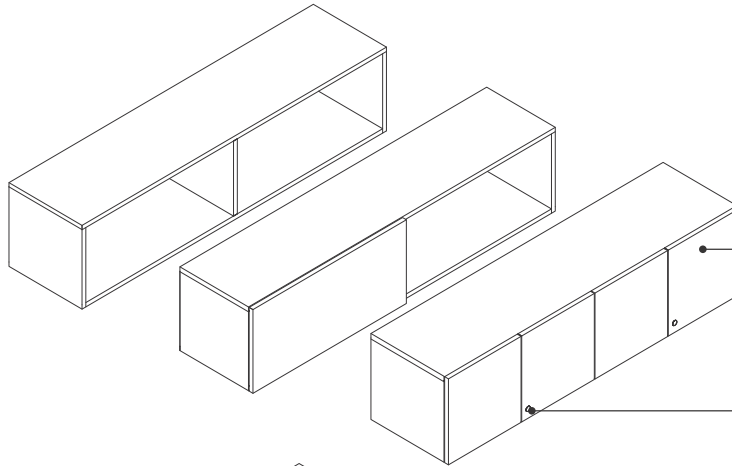
**Open overheads** have two equal-spaced openings.

**Stacking overheads** have end panels that allow the storage to sit on top of a worksurface. Stacking overheads allow for easy installation, and do not require anchoring to a wall. Stacking overheads must be placed up against a wall or back to back with a similar height unit.

**Stacking overheads** include a 1½" reveal for cable management.

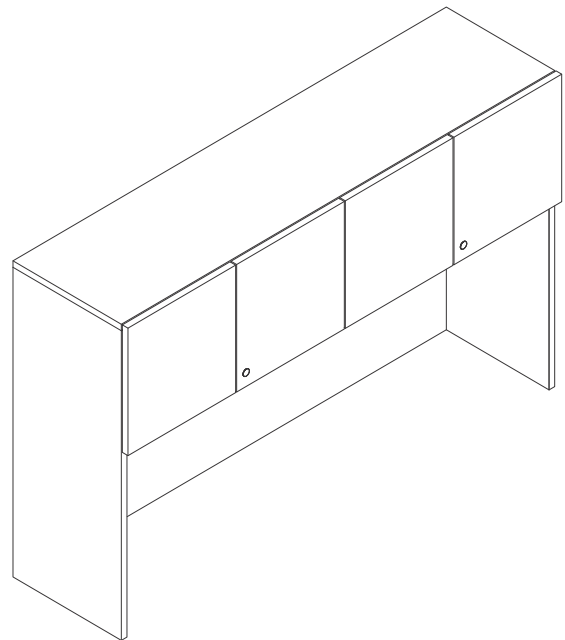
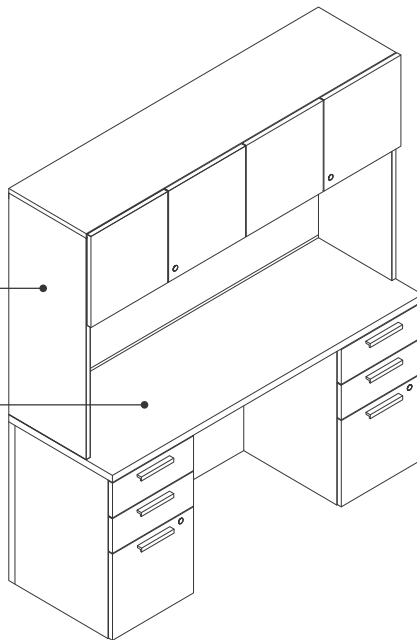
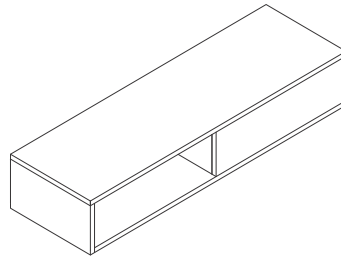
**Finished top, back, and sides** are standard on overheads and organizers.

**Tackboards for use with stacking overhead applications** will automatically deduct 2¼" from the overall width of tackboard and 1½" from the height of the tackboard to account for cable management clearance.



**Personal overhead and organizer configurations** provide access on one side of a unit. Cases have a fixed divider in the middle.

**Standard lock cylinders and keys** are included with Embank towers and wardrobes. If a master key is optioned, **AMQLOCK9201XF** must be specified to be included. All lock cylinders are field-installed.



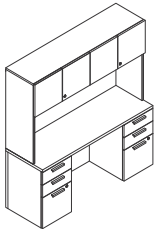
## Actual Dimensions

### Standard Widths

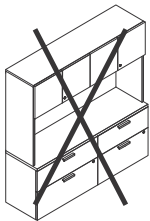
	Overheads with Sliding or Hinged Doors	Overheads with Open Fronts	Organizer
Depth	16"	15"	15"
Width	36", 42", 48", 60", 66", and 72"	36", 42", 48", 60", 66", and 72"	36", 42", 48", 60", 66", and 72"
Height	15"	15"	8 <sup>27</sup> / <sub>32</sub> "

**Product Details**

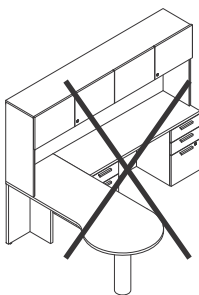
**Personal organizers** are available. They provide storage on one side and have a center divider.



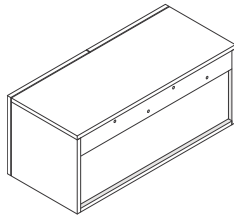
**Stacking overheads** attach to the top of a credenza, desk, desk shell, or Two-High freestanding laterals or low storage, using hardware included with the overhead unit. When placed on top of multiple lateral files or low storage, the storage units must be ganged together. Stacking overheads have a 1½" reveal for cable pass-through.



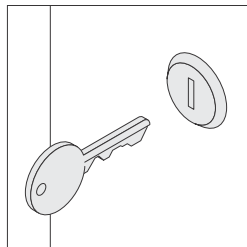
**Stacking overheads** cannot be used with lateral file/lateral file credenza configurations.



**Stacking overheads** cannot be used with P- or D-shape freestanding worksurfaces.



**Wall mount overheads** have a 1" gap between the back panel and end panel.

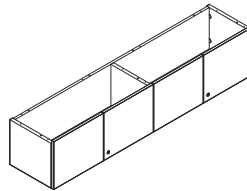


**Locks** are standard on overheads with hinged doors. Lock cylinders are standard and are field-installed. ▶ Lock and Keying, page 380

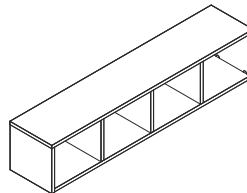
**Stacking overheads** are designed to align with other EMBANK tall storage heights. 38"H stacking overheads align with 66"H tall storage. 44"H stacking overheads align with 72"H tall storage. Selecting the correct worksurface thickness of the application ensures that the stacking overhead aligns with other tall storage.

**Overheads and organizers** have varying counts of doors or openings based on door type and width.

- Overheads with no doors less than 72"W have two openings.
- Organizers less than 72"W have two openings.
- Overheads with hinged doors less than 42"W have two doors.
- Overheads with hinged doors 42"–65<sup>15</sup>/<sub>16</sub>"W have three doors.
- Overheads with hinged doors 66"W or wider have four doors.
- Overheads with sliding doors always have one door that slides between two openings, any width.



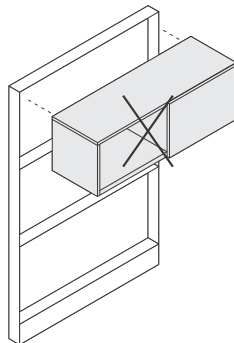
Hinged door—  
1 vertical interior divider



No door,  
greater than 72"W—  
3 interior dividers

**Overheads and organizers** have varying counts of vertical interior dividers based on door-type and width. Overheads with hinged doors have one vertical interior divider. Overheads with no doors and less than 72"W have one vertical interior divider.

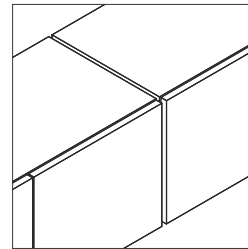
**Application Topics**



**Hanging components** cannot hang in front of a double-pane window.

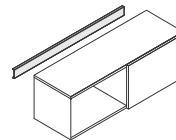
**Bracket options**  
▶ See below

**Stacking overheads** can be shorter than the supporting worksurface as long as a worksurface support or side panel of a storage unit is used under the worksurface within 6" of where the side of the stacking bookcase is loaded.

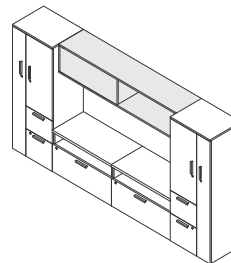


**Side-by-side wall mounted overheads** will have a slight gap in between units due to construction.

**Connections**



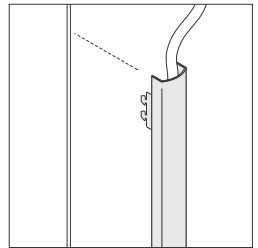
**Horizontal wall attachment brackets** are available to attach overhead storage to the wall of building.



**Overheads and organizers** have two attachment methods; a wall mount and suspension between towers. ▶ See below

**Overhead cabinets** can attach so they align with tower, vertical cabinet, and panel heights.

**Wiring and Cabling**



**Vertical wire managers** are available to conceal cords that are routed from light mounted beneath overhead storage.

**Surface Materials**

- Case and headsets**
- 24L0 Graphite Walnut
  - 25L5 Virginia Walnut
  - 25L8 Clear Walnut
  - 26L1 Natural Cherry
  - 2L09 Clear Maple
  - 2L30 Arctic White
  - 2L83 Seagull
  - 2L84 Milk
  - 2LAK Clear Oak
  - 2LAT Acacia
  - 2LAW Ash Wenge
  - 2LCN Clay Noce
  - 2LCW Clay Wenge
  - Markerboard—sliding door only

- Locks**
- 9201 Polished Chrome

**Bracket Options**

**Wall Mount**

**Personal Overhead/ Organizer**

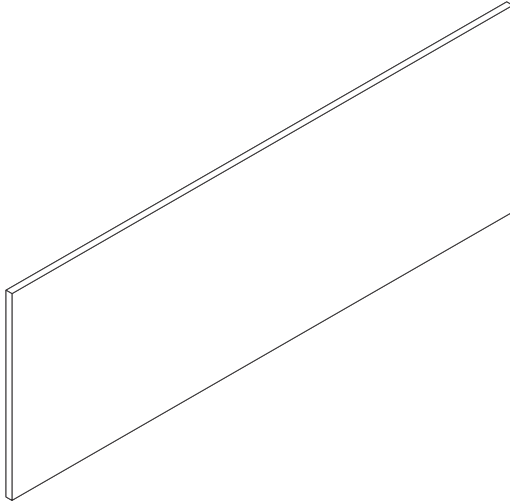
Select wall mount option. Brackets included.

**Suspended between EMBANK Towers**

Select suspended between towers option. Order cabinet-to-cabinet attachment kit (**AMQAWAK**) separately.

# EMBANK Tackboard

**Tackboard** finishes the space between an overhead unit and a worksurface. It is a fabric-covered tackable surface.



## Product Details

**Tackboards** provide a fabric covered tackable surface above the worksurface.

**The ends of wall-mounted tackboards** are finished.

**Tackboards for use with stacking overhead applications** will automatically deduct 2¼" from the overall width of the tackboard. Specify the width of the overhead it is being used with.

**Stacking overheads** include a 1½" space at the bottom of the end panel for cable management. When specifying a tackboard with a stacking overhead, remove 1½" from the overall height to account for this clearance.

- 37.9875"H stacking overheads should use a 21.4375"H tackboard for cable management.
- 44.17475"H stacking overhead would use a 27.6875"H tackboard or cable management.

## Connections

**Tackboards** attach with hook and loop fasteners. The attachment hardware is standard with the tackboard for field installation.

## Surface Materials

### Tackboards

#### Fabric Price Group 1

- 5F07 Blue
- 5F08 Navy
- 5F16 Grey
- 5F17 Black
- 5G64 Alpine
- 5G65 Tornado

#### Fabric Price Group 3

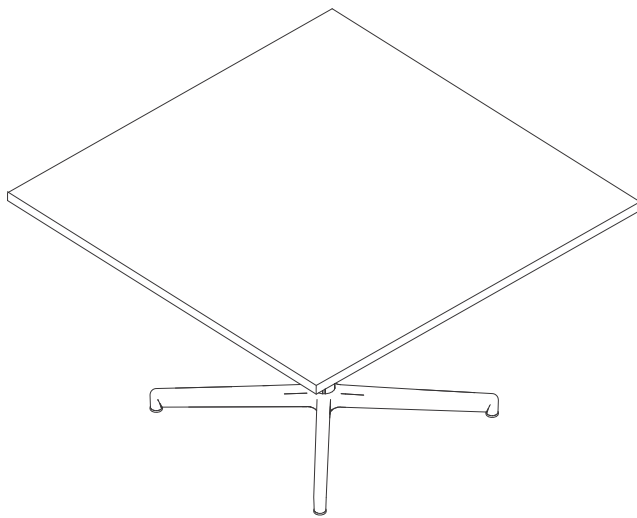
- 5H11 Poppy
- 5H12 Tangelo
- 5H13 Citrine (Citron)
- 5H14 Avocado
- 5H16 Indigo
- 5H17 Mallard
- 5H18 Teak
- 5H19 Cumulus
- 5H20 Pewter
- 5H21 Gunmetal
- 5H22 Ink
- 5H23 Rose Quartz
- 5H24 Sea Salt
- 5H25 Storm Cloud
- 5H26 Olivine

## Actual Dimensions

<b>Width</b>	36", 42", 48", 60", 66", and 72"
<b>Height</b>	20¼" and 26¼"
<b>Thickness</b>	1"

*Tip: Thickness includes a core tackboard, spacer, and attachment hardware.*

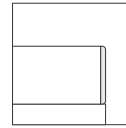
**EMBANK social tables** with X-style bases are ideal for quick meetings with a relaxed posture.



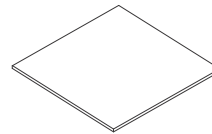
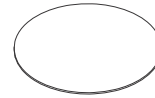
## Product Details

**Table tops** have a wood core with a Low-Pressure Laminate surface.

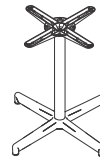
**Table tops** are available in 1 1/8" core thickness.



**Table tops** features a 3 mm square edge profile.



**EMBANK table tops** are available in round or square shapes.



**Steel X- bases** are available in 26"W and 36"W.

*Tip: When specifying a conference table, base size is predetermined by the selections made, and cannot be changed.*

## Surface Materials

### Table top

- 24L0 Graphite Walnut
- 25L5 Virginia Walnut
- 25L8 Clear Walnut
- 26L1 Natural Cherry
- 2L09 Clear Maple
- 2L30 Arctic White
- 2L83 Seagull
- 2L84 Milk
- 2LAK Clear Oak
- 2LAT Acacia
- 2LAW Ash Wenge
- 2LCN Clay Noce
- 2LCW Clay Wenge

### X-base

- 4799 Platinum Metallic
- 7207 Black

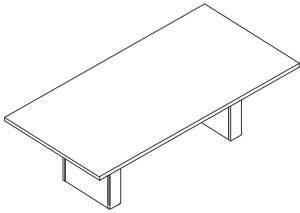
## Actual Dimensions

### EMBANK Tables

	Round	Square
<b>Diameter</b>	36", 48"	N.A.
<b>Depth</b>	N.A.	N.A.
<b>Width</b>	N.A.	36", 48"
<b>Height</b>	28"	28"

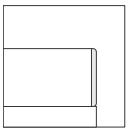
# EMBANK Rectangular Conference Tables

## Product Details



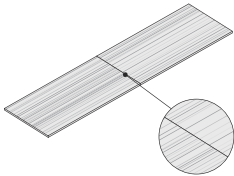
**Table tops** have a wood core with a Low-Pressure Laminate surface.

**Table tops** are available in 1½" core thickness.

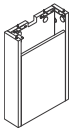


**Table tops** features a 3 mm square edge profile.

**Two-piece tops** will occur when the top is in Low-Pressure Laminate and is greater than or equal to 96"W. Tops will be split into two equal sections and ship with connecting hardware.



**Two-piece tops** will not have matching grain patterns.



**Rectangular table base** is available in Low-Pressure Laminate, and accommodates routing of power and data cords. Access is provided by a hinged door.

## Surface Materials

### Table top and rectangular table base

- 24L0 Graphite Walnut
- 25L5 Virginia Walnut
- 25L8 Clear Walnut
- 26L1 Natural Cherry
- 2L09 Clear Maple
- 2L30 Arctic White
- 2L83 Seagull
- 2L84 Milk
- 2LAK Clear Oak
- 2LAT Acacia
- 2LAW Ash Wenge
- 2LCN Clay Noce
- 2LCW Clay Wenge

### Edge profile

- 3 mm plastic

### Hinged door power unit

- 8043 Clear Anodized Aluminum

### Power outlet

- Black plastic

### Power cord

- Black plastic

## Power, Wiring & Cabling

**Grommet option** allows for either no grommet or hinged door power unit.

### Hinged door power unit

has two power outlets and openings for two data ports. The bottom of the units is open to allow pass-through of power and data cables to the floor. Available as an option on conference table tops. The door has a 6' power cord.

### Rectangular table base

accommodates routing of power and data cords. Access is provided by a hinged door.

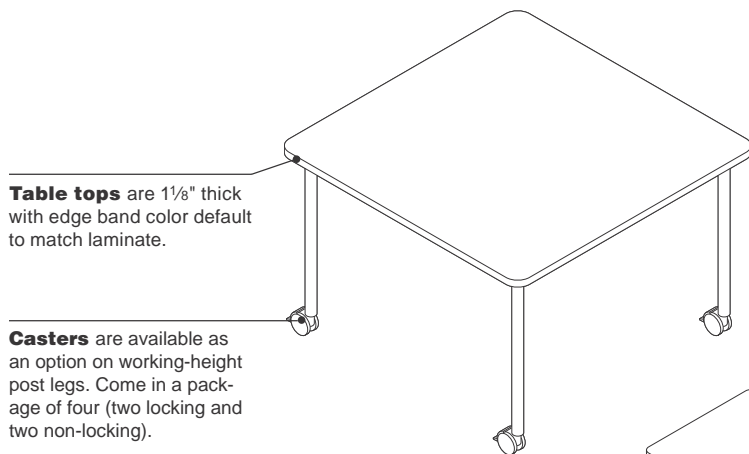


# EMBANK Collaborative Table & Cafe Height Table

## Embank collaborative and café height tables

come in two heights and two shapes.

► Specifying, pages 371–372



**Table tops** are 1½" thick with edge band color default to match laminate.

**Casters** are available as an option on working-height post legs. Come in a package of four (two locking and two non-locking).

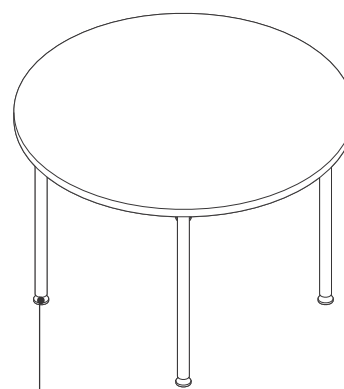
**Square table tops** come with all four edges crowned.

**Café-height tables (42"H)** are supported with column bases.

► Specifying, page 371

**Power** can be added to the collaborative and café height table, ordered as a separate style number.

► See page 374



**Collaborative tables (28½"H)** come standard with post legs on glides and are 1½" in diameter with 1" of leveling. Casters and column bases are available as an option on this table.

## Actual Dimensions

	Collaborative	Café-Height
Square	●	●
Round	●	●

### Product Details

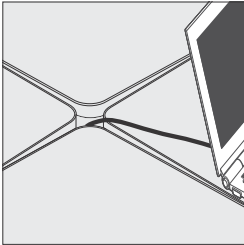
**Embank tables** come in two heights and two shapes:

- Collaborative, 28½"H. Shapes—Square, round,
- Café or standing height, 42"H. Shapes—Square and round.

**Table tops** are 1½" thick with edge band color default to match laminate.

**Bases** vary in size depending on the size of the table top.

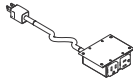
▶ See page 328



**Square tops** come with all four edges crowned.

### Power Specifications

**Single power unit** comes standard with plastic clips and two Velcro straps for cord management.



#### Single power unit

- Two power or one power/one dual USB-A
- 10 or 15 foot cord length

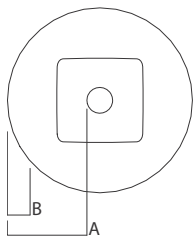
Determining power cord length depends on the size of the table top and distance to power source.

### Column Matrix

**Column and base sizes** are determined by the size of the table top.

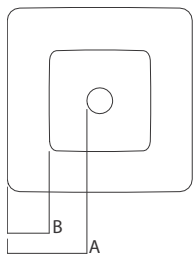
Table Width	Up to 30"W	31-54"W
<b>Column Size</b>	One 3" Column	One 5" Column

# EMBank Collaborative & Cafe Height Table— Column Style Base Dimensions



## Round Worksurfaces

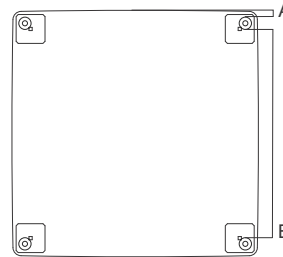
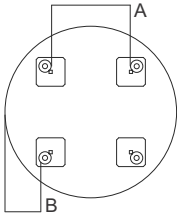
Width	To Column Dim A	To Base Dim B	Collaborative Weight	Café Weight
30"	13½"	4"	62 lb	65 lb
36"	15¾"	7"	80 lb	86 lb
48"	21¾"	12"	113 lb	N.A.



## Square Worksurfaces

Width	To Column Dim A	To Base Dim B	Collaborative Weight	Café Weight
30"	13½"	4"	69 lb	71 lb
36"	15¾"	7"	90 lb	95 lb
48"	21¾"	12"	110 lb	N.A.

**Embank Collaborative Tables**



<b>Round Worksurface Post Legs</b>			
Diameter	Between Posts	To Post	
	Dim A	Dim B	Weight
30"	13 <sup>5</sup> / <sub>8</sub> "	6 <sup>5</sup> / <sub>8</sub> "	44 lb
36"	17 <sup>1</sup> / <sub>4</sub> "	7 <sup>3</sup> / <sub>4</sub> "	55 lb
48"	24 <sup>3</sup> / <sub>8</sub> "	10 <sup>1</sup> / <sub>8</sub> "	82 lb

<b>Round Column Base (lamine top)</b>	
Diameter	Weight
30"	62 lb
36"	80 lb
48"	113 lb

<b>Round Post Legs</b>	
Diameter	Weight
30"	44 lb
36"	55 lb
48"	82 lb

<b>Round Café Height</b>	
Depth	Weight
30"	65 lb
36"	86 lb

<b>Square Worksurface Post Legs</b>			
Width	To Posts	Between Post	Weight
	Dim A	Dim B	
36"	2 <sup>3</sup> / <sub>8</sub> "	27 <sup>15</sup> / <sub>16</sub> "	64 lb
48"	2 <sup>3</sup> / <sub>8</sub> "	39 <sup>15</sup> / <sub>16</sub> "	98 lb

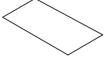
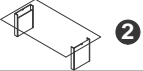
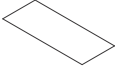
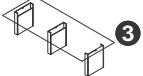
<b>Square Café Height</b>	
Depth	Weight
30"	71 lb
36"	95 lb

<b>Square Column Base</b>	
Width	Weight
30"	69 lb
36"	90 lb
48"	130 lb

<b>Square Post Legs</b>	
Width	Weight
30"	50 lb
36"	64 lb
48"	98 lb

# EMBANK Table Tops, Legs, and Base Combinations

## Rectangular Conference Table










	Rectangular Base		Steel X-Base	
	18"	24"	26"	36"
 Rectangle Tops 36 <sup>1</sup> / <sub>4</sub> "D– 48"D x 72"W–96"W	N.A.	 <b>2</b>	N.A.	N.A.
 Rectangle Tops 36 <sup>1</sup> / <sub>4</sub> "D– 48"D x 120"W–144"W	N.A.	 <b>3</b>	N.A.	N.A.

**1** = Number of base units to order.

# EMBANK Table Tops, Legs, and Base Combinations

EMBANK Table Tops, Legs,  
and Base Combinations

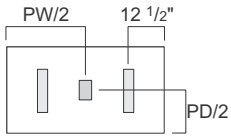
Social Table

		Rectangular Base	Steel X-Base	
		 24"	 30"	 36"
	Round Tops 36"W	N.A.		N.A.
	Round Tops 48"W	N.A.	N.A.	
	Square Tops 36"W and 48"W	N.A.	N.A.	

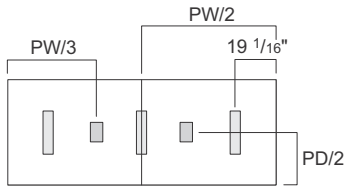
# EMBANK Rectangular Conference Table Power Unit

## Hinged Door Power Unit and Rectangular Base Locations

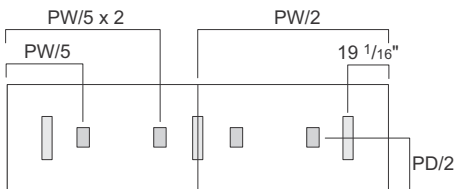
### Rectangular Tops



PW = 72" or 96"





PW = 120"

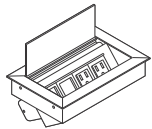


PW = 144"

PW = Planned Width  
PD = Planned Depth

Rectangular Base Location =   
Hinged Door Power Unit = 

### Hinged Door Power Unit



#### Product Details

**Hinged door power unit** provides two electrical outlets and two open ports for data adapters. Power unit features a hinged door that opens 90° for access to power and data and is flush with the worksurface when closed. It has a 6' cord with grounded plug. Available on conference table tops only.

**Hinged door power unit** is field installed in a factory cut hole.

#### Surface Materials

- Power Unit**
- 8043 Clear Anodized Aluminum
- Outlet**
- Black plastic only
- Power Cord**
- Black plastic only

#### Actual Dimensions

**Depth** 5<sup>3</sup>/<sub>8</sub>"

**Width** 8<sup>3</sup>/<sub>8</sub>"

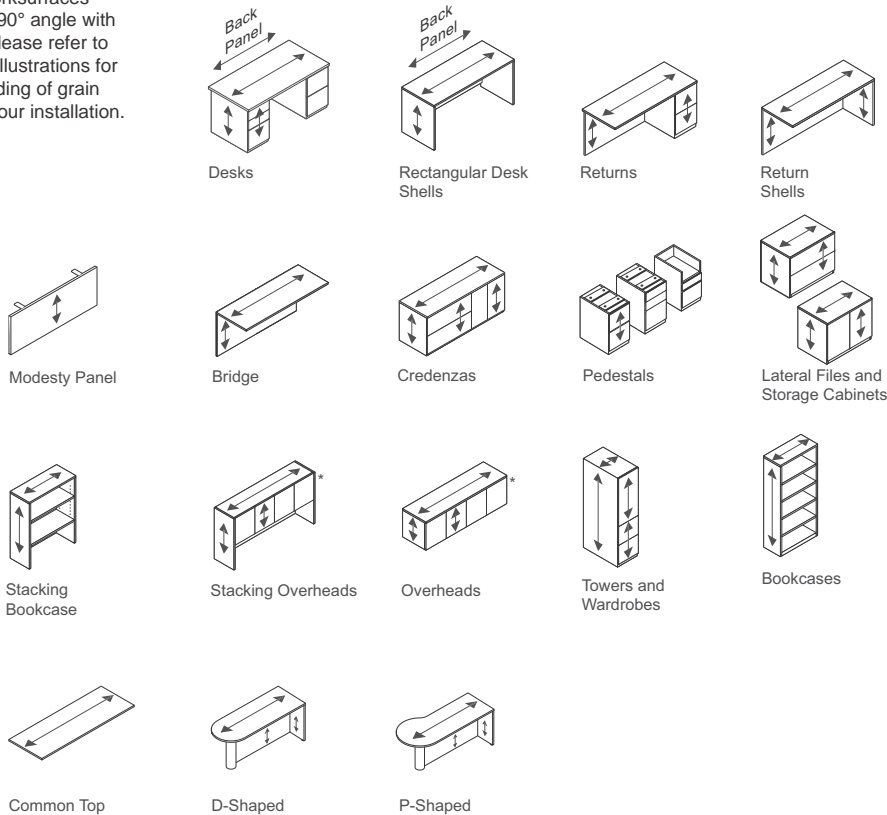
**Height** 3<sup>1</sup>/<sub>2</sub>"

**Power cord length** 6'

# Directional Laminate and Edge Profile Detail

Directional Laminate and  
Edge Profile Detail

**The appearance of laminate** may change slightly depending on the angle from which it is viewed. This natural phenomenon is called polarization, and it can be seen on natural veneer, and to a lesser extent on composite veneer. Polarization is often noticed on worksurfaces installed at a 90° angle with each other. Please refer to the following illustrations for an understanding of grain direction on your installation.



\* 36"W–61½"W overhead back panels have vertical grain direction. 63"W–75"W overhead back panels have horizontal grain direction.

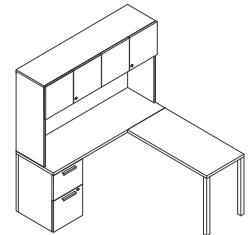
\* Towers, wardrobes, bookcases, returns, return shells, and bridges back/modesty panels have vertical grain direction.

\* Desks, desk shells, and credenzas 60"W or greater have horizontal grain on back/modesty panels.

## Product Details



**3 mm radius front edge profile**  
(1⅛" thick)



**3 mm Edge Profile Locations**

**User side only**

**Worksurfaces:**

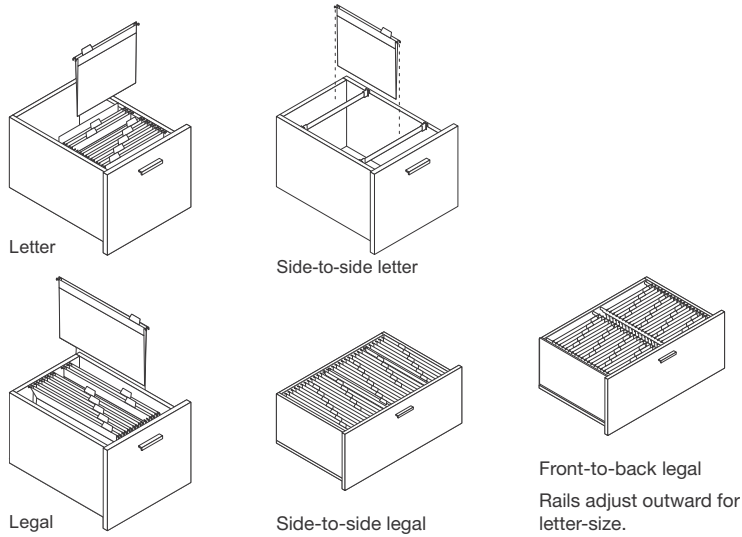
- Desks
- Desk shells
- Credenzas
- Returns
- Bridges

**Tops:**

- Lateral files
- Lower storage
- Credenzas
- Storage cabinets
- Overhead storage and wall-mounted overhead storage
- Towers
- Wardrobes
- Bookcases

# Storage Capacities and Dimensions

## Filing Types



## Pedestal Drawers

For pedestals, desks, returns, credenzas, and towers

### 6"H Box Drawers

	Size/Type	Inside Dimensions			Inside Height Clearance
		D	W	H	
	18"D Drawer	12 <sup>1</sup> / <sub>6</sub> "	12 <sup>1</sup> / <sub>6</sub> "	2 <sup>3</sup> / <sub>4</sub> "	4 <sup>2</sup> / <sub>5</sub> "
	22 <sup>3</sup> / <sub>4</sub> "D Drawer	15 <sup>1</sup> / <sub>6</sub> "	12 <sup>1</sup> / <sub>6</sub> "	2 <sup>3</sup> / <sub>4</sub> "	4 <sup>2</sup> / <sub>5</sub> "
	24"D Drawer	15 <sup>1</sup> / <sub>6</sub> "	12 <sup>1</sup> / <sub>6</sub> "	2 <sup>3</sup> / <sub>4</sub> "	4 <sup>2</sup> / <sub>5</sub> "
	30"D Drawer	15 <sup>1</sup> / <sub>6</sub> "	12 <sup>1</sup> / <sub>6</sub> "	2 <sup>3</sup> / <sub>4</sub> "	4 <sup>2</sup> / <sub>5</sub> "

### 12"H File Drawers

	Size/Type	Inside Dimensions			Inside Height Clearance	Letter-Sized Storage	Legal-Sized Storage
		D	W	H			
	18"D Drawer	12 <sup>1</sup> / <sub>6</sub> "	12 <sup>1</sup> / <sub>6</sub> "	9 <sup>1</sup> / <sub>6</sub> "	10 <sup>31</sup> / <sub>32</sub> "	12" front-to-back 12" side-to-side	N.A.
	22 <sup>3</sup> / <sub>4</sub> "D Drawer	15 <sup>1</sup> / <sub>6</sub> "	15 <sup>1</sup> / <sub>6</sub> "	9 <sup>1</sup> / <sub>6</sub> "	10 <sup>31</sup> / <sub>32</sub> "	12" front-to-back 12" side-to-side	N.A.
	24"D Drawer	15 <sup>1</sup> / <sub>6</sub> "	12 <sup>1</sup> / <sub>6</sub> "	9 <sup>1</sup> / <sub>6</sub> "	10 <sup>31</sup> / <sub>32</sub> "	15" front-to-back 12" side-to-side	12" side-to-side
	30"D Drawer	15 <sup>1</sup> / <sub>6</sub> "	12 <sup>1</sup> / <sub>6</sub> "	9 <sup>1</sup> / <sub>6</sub> "	10 <sup>31</sup> / <sub>32</sub> "	15" front-to-back 12" side-to-side	12" side-to-side

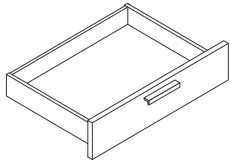


# Bookcase Shelf Counts

## Lateral File Drawers

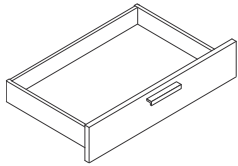
For lateral files and credenzas

### 30"W Box Drawers



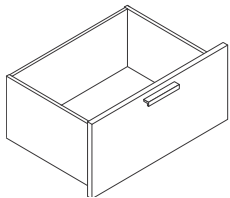
Size/Type	Inside Dimensions			Inside Height Clearance
	D	W	H	
18"D Drawer	12 <sup>1</sup> / <sub>6</sub> "	25 <sup>2</sup> / <sub>3</sub> "	2 <sup>4</sup> / <sub>5</sub> "	4 <sup>7</sup> / <sub>8</sub> "
22 <sup>3</sup> / <sub>4</sub> "D Drawer	12 <sup>1</sup> / <sub>6</sub> "	25 <sup>2</sup> / <sub>3</sub> "	2 <sup>4</sup> / <sub>5</sub> "	4 <sup>7</sup> / <sub>8</sub> "
24"D Drawer	15 <sup>1</sup> / <sub>6</sub> "	25 <sup>2</sup> / <sub>3</sub> "	2 <sup>4</sup> / <sub>5</sub> "	4 <sup>7</sup> / <sub>8</sub> "

### 36"W Box Drawers



Size/Type	Inside Dimensions			Inside Height Clearance
	D	W	H	
18"D Drawer	12 <sup>1</sup> / <sub>6</sub> "	31 <sup>2</sup> / <sub>3</sub> "	2 <sup>4</sup> / <sub>5</sub> "	4 <sup>7</sup> / <sub>8</sub> "
22 <sup>3</sup> / <sub>4</sub> "D Drawer	12 <sup>1</sup> / <sub>6</sub> "	31 <sup>2</sup> / <sub>3</sub> "	2 <sup>4</sup> / <sub>5</sub> "	4 <sup>7</sup> / <sub>8</sub> "
24"D Drawer	15 <sup>1</sup> / <sub>6</sub> "	31 <sup>2</sup> / <sub>3</sub> "	2 <sup>4</sup> / <sub>5</sub> "	4 <sup>7</sup> / <sub>8</sub> "

### 30"W File Drawers

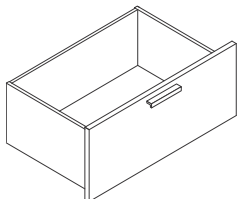


Size/Type	Inside Dimensions			Inside Height Clearance	Letter-Sized Storage	Legal-Sized Storage
	D	W	H			
18"D Drawer	12 <sup>1</sup> / <sub>6</sub> "	25 <sup>2</sup> / <sub>3</sub> "	9 <sup>1</sup> / <sub>6</sub> "	10 <sup>31</sup> / <sub>32</sub> "**	24" front-to-back* 25" side-to-side	12" front-to-back
22 <sup>3</sup> / <sub>4</sub> "D Drawer	12 <sup>1</sup> / <sub>6</sub> "	25 <sup>2</sup> / <sub>3</sub> "	9 <sup>1</sup> / <sub>6</sub> "	10 <sup>31</sup> / <sub>32</sub> "**	24" front-to-back* 25" side-to-side	12" front-to-back
24"D Drawer	15 <sup>1</sup> / <sub>6</sub> "	25 <sup>2</sup> / <sub>3</sub> "	9 <sup>1</sup> / <sub>6</sub> "	10 <sup>31</sup> / <sub>32</sub> "**	30" front-to-back* 25" side-to-side	15" front-to-back + 10" 25" side-to-side

\*Three-High and Four-High lateral files have an inside clearance height of 10<sup>1</sup>/<sub>4</sub>" on top drawer and third drawer down.

\*Two rows

### 36"W File Drawers



Size/Type	Inside Dimensions			Inside Height Clearance	Letter-Sized Storage	Legal-Sized Storage
	D	W	H			
18"D Drawer	12 <sup>1</sup> / <sub>6</sub> "	31 <sup>2</sup> / <sub>3</sub> "	9 <sup>1</sup> / <sub>6</sub> "	10 <sup>31</sup> / <sub>32</sub> "**	24" front-to-back* 31" side-to-side	24" front-to-back*
22 <sup>3</sup> / <sub>4</sub> "D Drawer	12 <sup>1</sup> / <sub>6</sub> "	31 <sup>2</sup> / <sub>3</sub> "	9 <sup>1</sup> / <sub>6</sub> "	10 <sup>31</sup> / <sub>32</sub> "**	24" front-to-back* 31" side-to-side	24" front-to-back*
24"D Drawer	15 <sup>1</sup> / <sub>6</sub> "	31 <sup>2</sup> / <sub>3</sub> "	9 <sup>1</sup> / <sub>6</sub> "	10 <sup>31</sup> / <sub>32</sub> "**	30" front-to-back* 31" side-to-side	30" front-to-back* 31" side-to-side

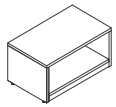
\*Three-High and Four-High lateral files have an inside clearance height of 10<sup>1</sup>/<sub>4</sub>" on top drawer and third drawer down.

\*Two rows

## Lateral File Drawers, continued

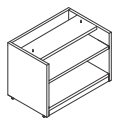
For lateral files and credenzas

### One-High Low Storage Units



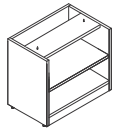
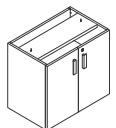
Size/Type	Inside Dimensions		
	D	W	H
30"W x 18"D	17"	28 <sup>1</sup> / <sub>4</sub> "	11 <sup>1</sup> / <sub>5</sub> "
36"W x 18"D	17"	34 <sup>1</sup> / <sub>4</sub> "	11 <sup>1</sup> / <sub>5</sub> "
42"W x 18"D	17"	40 <sup>1</sup> / <sub>4</sub> "	11 <sup>1</sup> / <sub>5</sub> "
30"W x 24"D	22 <sup>1</sup> / <sub>6</sub> "	28 <sup>1</sup> / <sub>4</sub> "	11 <sup>1</sup> / <sub>5</sub> "
36"W x 24"D	22 <sup>1</sup> / <sub>6</sub> "	34 <sup>1</sup> / <sub>4</sub> "	11 <sup>1</sup> / <sub>5</sub> "
42"W x 24"D	22 <sup>1</sup> / <sub>6</sub> "	40 <sup>1</sup> / <sub>4</sub> "	11 <sup>1</sup> / <sub>5</sub> "

### 1.5-High Low Storage Units



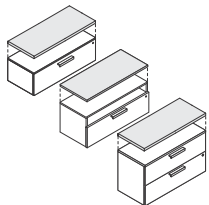
Size/Type	Inside Dimensions		
	D	W	H
30"W x 18"D	17"	28 <sup>1</sup> / <sub>4</sub> "	17 <sup>1</sup> / <sub>5</sub> "
36"W x 18"D	17"	34 <sup>1</sup> / <sub>4</sub> "	17 <sup>1</sup> / <sub>5</sub> "
42"W x 18"D	17"	40 <sup>1</sup> / <sub>4</sub> "	17 <sup>1</sup> / <sub>5</sub> "
30"W x 24"D	22 <sup>1</sup> / <sub>6</sub> "	28 <sup>1</sup> / <sub>4</sub> "	17 <sup>1</sup> / <sub>5</sub> "
36"W x 24"D	22 <sup>1</sup> / <sub>6</sub> "	34 <sup>1</sup> / <sub>4</sub> "	17 <sup>1</sup> / <sub>5</sub> "
42"W x 24"D	22 <sup>1</sup> / <sub>6</sub> "	40 <sup>1</sup> / <sub>4</sub> "	17 <sup>1</sup> / <sub>5</sub> "

### Two-High Low Storage Units



Size/Type	Inside Dimensions		
	D	W	H
30"W x 24"D	22 <sup>1</sup> / <sub>6</sub> "	28 <sup>1</sup> / <sub>4</sub> "	25 <sup>1</sup> / <sub>5</sub> "
36"W x 24"D	22 <sup>1</sup> / <sub>6</sub> "	34 <sup>1</sup> / <sub>4</sub> "	25 <sup>1</sup> / <sub>5</sub> "

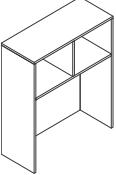
### Cushions

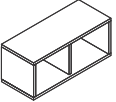


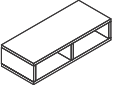
Size/Type	Inside Dimensions		
	D	W	H
30"W x 24"D	23 <sup>1</sup> / <sub>6</sub> "	30"	1"
36"W x 24"D	23 <sup>1</sup> / <sub>6</sub> "	36"	1"

*Tip: Bracing option would allow cushion to work without a top.*

### Overheads and Organizers

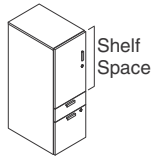
Stacking Overhead	Size/Type	Inside Dimensions		
		D	W	H
	60"W	13 <sup>9</sup> / <sub>10</sub> "	57 <sup>4</sup> / <sub>5</sub> "	12 <sup>7</sup> / <sub>8</sub> "
	66"W	13 <sup>9</sup> / <sub>10</sub> "	63 <sup>4</sup> / <sub>5</sub> "	12 <sup>7</sup> / <sub>8</sub> "
	72"W	13 <sup>9</sup> / <sub>10</sub> "	69 <sup>4</sup> / <sub>5</sub> "	12 <sup>7</sup> / <sub>8</sub> "

Overhead	Size/Type	Inside Dimensions		H (for all other)
		D (for Wall Mount)	W	
	36"W	13 <sup>1</sup> / <sub>6</sub> "	33 <sup>4</sup> / <sub>5</sub> "	12 <sup>7</sup> / <sub>8</sub> "
	42"W	13 <sup>1</sup> / <sub>6</sub> "	39 <sup>4</sup> / <sub>5</sub> "	12 <sup>7</sup> / <sub>8</sub> "
	48"W	13 <sup>1</sup> / <sub>6</sub> "	45 <sup>4</sup> / <sub>5</sub> "	12 <sup>7</sup> / <sub>8</sub> "
	54"W	13 <sup>1</sup> / <sub>6</sub> "	51 <sup>4</sup> / <sub>5</sub> "	12 <sup>7</sup> / <sub>8</sub> "
	60"W	13 <sup>1</sup> / <sub>6</sub> "	57 <sup>4</sup> / <sub>5</sub> "	12 <sup>7</sup> / <sub>8</sub> "
	66"W	13 <sup>1</sup> / <sub>6</sub> "	63 <sup>4</sup> / <sub>5</sub> "	12 <sup>7</sup> / <sub>8</sub> "
	72"W	13 <sup>1</sup> / <sub>6</sub> "	69 <sup>4</sup> / <sub>5</sub> "	12 <sup>7</sup> / <sub>8</sub> "

Organizer	Size/Type	Inside Dimensions		H (for all other)
		D (for Wall Mount)	W	
	36"W	13 <sup>1</sup> / <sub>6</sub> "	33 <sup>4</sup> / <sub>5</sub> "	6 <sup>2</sup> / <sub>5</sub> "
	42"W	13 <sup>1</sup> / <sub>6</sub> "	39 <sup>4</sup> / <sub>5</sub> "	7 <sup>2</sup> / <sub>5</sub> "
	48"W	13 <sup>1</sup> / <sub>6</sub> "	45 <sup>4</sup> / <sub>5</sub> "	8 <sup>2</sup> / <sub>5</sub> "
	54"W	13 <sup>1</sup> / <sub>6</sub> "	51 <sup>4</sup> / <sub>5</sub> "	9 <sup>2</sup> / <sub>5</sub> "
	60"W	13 <sup>1</sup> / <sub>6</sub> "	57 <sup>4</sup> / <sub>5</sub> "	10 <sup>2</sup> / <sub>5</sub> "
	66"W	13 <sup>1</sup> / <sub>6</sub> "	63 <sup>4</sup> / <sub>5</sub> "	11 <sup>2</sup> / <sub>5</sub> "
	72"W	13 <sup>1</sup> / <sub>6</sub> "	69 <sup>4</sup> / <sub>5</sub> "	12 <sup>2</sup> / <sub>5</sub> "

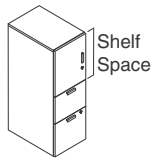
## Towers

### Single Door, Box/File



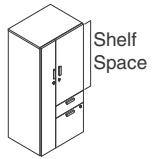
Size/Type	Inside Dimensions		
	D	W	H
42"H	22 <sup>1</sup> / <sub>5</sub> "	14 <sup>1</sup> / <sub>5</sub> "	19 <sup>1</sup> / <sub>10</sub> "
48"H	22 <sup>1</sup> / <sub>5</sub> "	14 <sup>1</sup> / <sub>5</sub> "	29 <sup>3</sup> / <sub>10</sub> "
54"H	22 <sup>1</sup> / <sub>5</sub> "	14 <sup>1</sup> / <sub>5</sub> "	31 <sup>15</sup> / <sub>32</sub> "
66"H	22 <sup>1</sup> / <sub>5</sub> "	14 <sup>1</sup> / <sub>5</sub> "	43 <sup>13</sup> / <sub>16</sub> "

### Single Door, File/File



Size/Type	Inside Dimensions		
	D	W	H
42"H	22 <sup>1</sup> / <sub>5</sub> "	14 <sup>1</sup> / <sub>5</sub> "	13 <sup>1</sup> / <sub>20</sub> "
48"H	22 <sup>1</sup> / <sub>5</sub> "	14 <sup>1</sup> / <sub>5</sub> "	19 <sup>1</sup> / <sub>4</sub> "
54"H	22 <sup>1</sup> / <sub>5</sub> "	14 <sup>1</sup> / <sub>5</sub> "	25 <sup>2</sup> / <sub>5</sub> "
66"H	22 <sup>1</sup> / <sub>5</sub> "	14 <sup>1</sup> / <sub>5</sub> "	37 <sup>3</sup> / <sub>4</sub> "

### Dual Door, Box/File



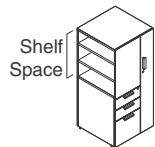
Size/Type	Inside Dimensions		
	D	W	H
42"H x 24"D	22 <sup>1</sup> / <sub>5</sub> "	14 <sup>1</sup> / <sub>5</sub> "	19 <sup>1</sup> / <sub>10</sub> "
48"H x 24"D	22 <sup>1</sup> / <sub>5</sub> "	14 <sup>1</sup> / <sub>5</sub> "	29 <sup>3</sup> / <sub>10</sub> "
54"H x 24"D	22 <sup>1</sup> / <sub>5</sub> "	14 <sup>1</sup> / <sub>5</sub> "	31 <sup>15</sup> / <sub>32</sub> "
66"H x 24"D	22 <sup>1</sup> / <sub>5</sub> "	14 <sup>1</sup> / <sub>5</sub> "	43 <sup>13</sup> / <sub>16</sub> "

### Dual Door, File/File

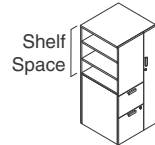


Size/Type	Inside Dimensions		
	D	W	H
42"H x 24"D	22 <sup>1</sup> / <sub>5</sub> "	14 <sup>1</sup> / <sub>5</sub> "	13 <sup>1</sup> / <sub>20</sub> "
48"H x 24"D	22 <sup>1</sup> / <sub>5</sub> "	14 <sup>1</sup> / <sub>5</sub> "	19 <sup>1</sup> / <sub>4</sub> "
54"H x 24"D	22 <sup>1</sup> / <sub>5</sub> "	14 <sup>1</sup> / <sub>5</sub> "	25 <sup>2</sup> / <sub>5</sub> "
66"H x 24"D	22 <sup>1</sup> / <sub>5</sub> "	14 <sup>1</sup> / <sub>5</sub> "	37 <sup>3</sup> / <sub>4</sub> "

### Side Access

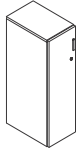


Size/Type	Inside Dimensions		
	D	W	H
42"H	15 <sup>1</sup> / <sub>20</sub> "	22 <sup>1</sup> / <sub>4</sub> "	12 <sup>7</sup> / <sub>16</sub> "
48"H	15 <sup>1</sup> / <sub>20</sub> "	22 <sup>1</sup> / <sub>4</sub> "	18 <sup>3</sup> / <sub>5</sub> "
54"H	15 <sup>1</sup> / <sub>20</sub> "	22 <sup>1</sup> / <sub>4</sub> "	24 <sup>25</sup> / <sub>32</sub> "
66"H	15 <sup>1</sup> / <sub>20</sub> "	22 <sup>1</sup> / <sub>4</sub> "	37 <sup>5</sup> / <sub>32</sub> "



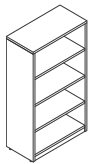
*Tip: For drawer inside dimensions, please see pedestals and lateral drawers.*

### Wardrobes



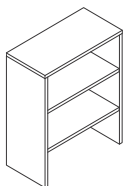
Size/Type	Inside Dimensions		
	D	W	H
42"H x 24"D	22 <sup>1</sup> / <sub>8</sub> "	10 <sup>1</sup> / <sub>4</sub> "	36 <sup>13</sup> / <sub>16</sub> "
48"H x 24"D	22 <sup>1</sup> / <sub>8</sub> "	10 <sup>1</sup> / <sub>4</sub> "	43"
54"H x 24"D	22 <sup>1</sup> / <sub>8</sub> "	10 <sup>1</sup> / <sub>4</sub> "	49 <sup>1</sup> / <sub>8</sub> "

### Bookcases



Size/Type	Inside Dimensions		Top Shelf Space	Bottom Shelf Space	Row of Binders Accommodated
	D	W			
42"H x 30"W	14 <sup>5</sup> / <sub>16</sub> "	27 <sup>4</sup> / <sub>8</sub> "	12 <sup>19</sup> / <sub>32</sub> "	9 <sup>17</sup> / <sub>18</sub> "	2
48"H x 30"W	14 <sup>5</sup> / <sub>16</sub> "	27 <sup>4</sup> / <sub>8</sub> "	13 <sup>31</sup> / <sub>32</sub> "	12 <sup>3</sup> / <sub>16</sub> "	2
54"H x 30"W	14 <sup>5</sup> / <sub>16</sub> "	27 <sup>4</sup> / <sub>8</sub> "	12 <sup>1</sup> / <sub>8</sub> "	9 <sup>17</sup> / <sub>18</sub> "	3
66"H x 30"W	14 <sup>5</sup> / <sub>16</sub> "	27 <sup>4</sup> / <sub>8</sub> "	11 <sup>11</sup> / <sub>32</sub> "	9 <sup>17</sup> / <sub>18</sub> "	4
72"H x 30"W	14 <sup>5</sup> / <sub>16</sub> "	27 <sup>4</sup> / <sub>8</sub> "	13 <sup>1</sup> / <sub>5</sub> "	9 <sup>17</sup> / <sub>18</sub> "	4
42"H x 36"W	14 <sup>5</sup> / <sub>16</sub> "	33 <sup>4</sup> / <sub>8</sub> "	12 <sup>19</sup> / <sub>32</sub> "	9 <sup>17</sup> / <sub>18</sub> "	2
48"H x 36"W	14 <sup>5</sup> / <sub>16</sub> "	33 <sup>4</sup> / <sub>8</sub> "	13 <sup>31</sup> / <sub>32</sub> "	12 <sup>3</sup> / <sub>16</sub> "	2
54"H x 36"W	14 <sup>5</sup> / <sub>16</sub> "	33 <sup>4</sup> / <sub>8</sub> "	12 <sup>1</sup> / <sub>8</sub> "	9 <sup>17</sup> / <sub>18</sub> "	3
66"H x 36"W	14 <sup>5</sup> / <sub>16</sub> "	33 <sup>4</sup> / <sub>8</sub> "	11 <sup>11</sup> / <sub>32</sub> "	9 <sup>17</sup> / <sub>18</sub> "	4
72"H x 36"W	14 <sup>5</sup> / <sub>16</sub> "	33 <sup>4</sup> / <sub>8</sub> "	13 <sup>1</sup> / <sub>5</sub> "	9 <sup>17</sup> / <sub>18</sub> "	4

### Stacking Bookcases



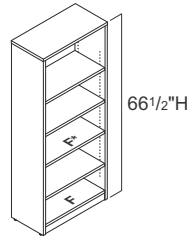
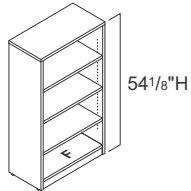
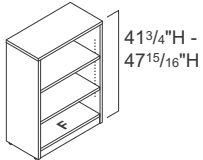
Size/Type	Inside Dimensions		Top Shelf Space	Bottom Shelf Space	2nd from Bottom
	D	W			
25 <sup>5</sup> / <sub>8</sub> "H x 30"W	14 <sup>1</sup> / <sub>10</sub> "	27 <sup>3</sup> / <sub>4</sub> "	12 <sup>1</sup> / <sub>8</sub> "	11 <sup>2</sup> / <sub>5</sub> "	N.A.
37 <sup>3</sup> / <sub>32</sub> "H x 30"W	14 <sup>1</sup> / <sub>10</sub> "	27 <sup>3</sup> / <sub>4</sub> "	11 <sup>3</sup> / <sub>8</sub> "	11 <sup>2</sup> / <sub>5</sub> "	12 <sup>3</sup> / <sub>16</sub> "
44 <sup>3</sup> / <sub>16</sub> "H x 30"W	14 <sup>1</sup> / <sub>10</sub> "	27 <sup>3</sup> / <sub>4</sub> "	13 <sup>1</sup> / <sub>4</sub> "	13 <sup>5</sup> / <sub>8</sub> "	14 <sup>1</sup> / <sub>5</sub> "
25 <sup>5</sup> / <sub>8</sub> "H x 36"W	14 <sup>1</sup> / <sub>10</sub> "	33 <sup>3</sup> / <sub>4</sub> "	12 <sup>1</sup> / <sub>8</sub> "	11 <sup>2</sup> / <sub>5</sub> "	N.A.
37 <sup>3</sup> / <sub>32</sub> "H x 36"W	14 <sup>1</sup> / <sub>10</sub> "	33 <sup>3</sup> / <sub>4</sub> "	11 <sup>3</sup> / <sub>8</sub> "	11 <sup>2</sup> / <sub>5</sub> "	12 <sup>3</sup> / <sub>16</sub> "
44 <sup>3</sup> / <sub>16</sub> "H x 36"W	14 <sup>1</sup> / <sub>10</sub> "	33 <sup>3</sup> / <sub>4</sub> "	13 <sup>1</sup> / <sub>4</sub> "	13 <sup>5</sup> / <sub>8</sub> "	14 <sup>1</sup> / <sub>5</sub> "

## Bookcase Shelf Counts by Height

See below for count of adjustable shelves by height for freestanding bookcase, **AMQCRBK**.

### 2 Adjustable Shelves

### 3 Adjustable Shelves



F= Fixed shelf

*\*Fixed shelf at worksurface height for bookcases 66 1/2\"/>*

Modular Height	Number of Adjustable Shelves	Number of Fixed Shelves
41 <sup>3</sup> / <sub>4</sub> "	2	1
47 <sup>15</sup> / <sub>16</sub> "	2	1
54 <sup>1</sup> / <sub>8</sub> "	3	1
66 <sup>1</sup> / <sub>2</sub> "	3	2
72"	3	2

# Tower and Wardrobe Interior Configurations

## Towers

### Single-Door Towers and Dual-Door Towers with Box/File (AMQCRTWBFL, AMQCRTWBFR, AMQCRTWDBFL, AMQCRTWDBFR)

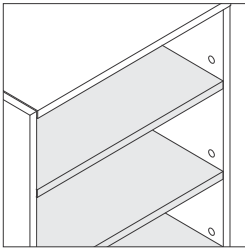
- $H < 48"$  = 1 fixed bottom shelf
- $48" \leq H < 66"$  = 1 fixed bottom shelf and 1 adjustable shelf

### Single-Door Towers and Dual-Door Towers with File/File (AMQCRTWFFL, AMQCRTWFFR, AMQCRTWDFFL, AMQCRTWDFFR)

- $H < 54"$  = 1 fixed bottom shelf
- $54" \leq H < 66"$  = 1 fixed bottom shelf and 1 adjustable shelf

### Side Access Towers (AMQCRTWSABBFL, AMQCRTWSABBFR, AMQCRTWSAFL, AMQCRTWSAFFR)

- $H < 54"$  = 1 fixed bottom shelf and 0 adjustable shelves
- $54" \leq H < 66"$  = 1 fixed bottom shelf and 1 adjustable shelf



# EMBANK Finish Availability Matrix

	Credenzas	Desks	Common Tops	D and P Shape Tops	Fixed Pedestals	Mobile Pedestals	Low Storage/Lateral Files	3/4 High Laterals	Bridges	Towers/Wardrobes	Bookcases	Overheads/Organizers
<b>Top</b>	X	X	X	X	X	X	X	X	X			
<b>Case</b>	X	X		X	X	X	X	X	X	X	X	X
<b>Headset</b>	X	X			X	X	X	X		X		X
<b>Edgeband</b>	X	X	X	X		X	X	X	X			

Tip: Social tables are available with contrasting top and edgeband finish, collaborative tables must have matching tops and edge bands.

Tip: Rectangular conference tables allow for a contrasting base in addition to the top and edgeband.

## Edgeband Finish

## Top, Case, and Headset Finish

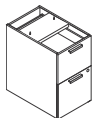
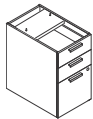
6009 Arctic White	2L30 Arctic White
6034 Natural Cherry	26L1 Natural Cherry
6052 Milk	2L84 Milk
6053 Seagull	2L83 Seagull
6213 Acacia	2LAT Acacia
6219 Clear Oak	2LAK Clear Oak
6231 Graphite Walnut	24L0 Graphite Walnut
6237 Clear Maple	2L09 Clear Maple
6242 Virginia Walnut	25L5 Virginia Walnut
6245 Clear Walnut	25L8 Clear Walnut
6703 Ash Wenge	2LAW Ash Wenge
6706 Clay Wenge	2LCW Clay Wenge
6709 Clay Noce	2LCN Clay Noce

# Two-High Fixed Pedestals

*Tip: Specify fixed pedestals as structural support. It is recommended to use fixed pedestals under a common top.*

*Tip: Fixed pedestals cannot be specified for credenzas or desks. If storage is required for credenzas or desks, please specify these products with storage already attached.*

*Tip: If the master key plug is optioned, **AMQLOCK9201XF** must be specified separately to be included.*



Standard Includes	Required to Specify
<ul style="list-style-type: none"> <li>Fixed pedestal, 1.5-High and Two-High: Low-Pressure Laminate case with matching or contrasting Low-Pressure Laminate headset</li> <li>Finished back</li> <li>Bore and dowel drawer construction: black</li> <li>One fastened metal filing system per file drawer: black only</li> <li>Full extension, heavy-duty ball bearing drawer suspensions</li> <li>Ledge pull: paint</li> <li>One pencil tray is included in units with a box drawer</li> <li>Lock plug: polished chrome</li> <li>Lock cylinder included in package, field-installed</li> <li>Counterweight</li> <li>Attachment hardware</li> <li>1 1/4" adjustable leveling glides</li> <li>Shipped fully assembled</li> </ul>	<ol style="list-style-type: none"> <li>Style number</li> <li>Low-Pressure Laminate color number for pedestal and headset</li> <li>Paint color number for pull</li> <li>Options, if selected (see below)</li> </ol> <p>▶ See <i>Surface Materials</i>, page 506.</p>

Options	U.S. Price	Required to Specify
<b>Keys</b> <ul style="list-style-type: none"> <li>Standard key plug</li> <li>Master key plug</li> </ul>	No cost +\$39	Specify with standard key plug. Specify with master key plug.

## Specification Information

Style Number	Dimensions D W H	U.S. Base Price

### Two Box Drawers and One File Drawer

<b>AMQCRPD2HBBF</b>	24" 15 3/4" 27 5/16"	\$1131
	30" 15 3/4" 27 5/16"	\$1260

### Two File Drawers

<b>AMQCRPD2HFF</b>	24" 15 3/4" 27 5/16"	\$1131
	30" 15 3/4" 27 5/16"	\$1260

**For Canadian Pricing**  
Multiply U.S. Price by the Canadian price factor.  
▶ See page 1 for details.

Tip: Specify mobile pedestals as stand-alone unit.

Tip: Actual cushion thickness is 1½"H.

Tip: Counterweight type and quantity varies depending on size and storage configuration. Please refer to the electronic catalog or SmartTools.

Tip: If the master key plug is optioned, **AMQLOCK9201XF** must be specified separately to be included.



Tip: Two-High mobile pedestals with a cushion top will not fit under a desk.



Tip: Two-High mobile pedestals with a cushion top will not fit under a desk.

Tip: Embank storage is slightly deeper than the depth of the cushion top.

Standard Includes	Required to Specify
<ul style="list-style-type: none"> <li>Mobile pedestal, 1.5-High and Two-High: Low-Pressure Laminate case with matching or contrasting Low-Pressure Laminate headset</li> <li>Top: Low-Pressure Laminate</li> <li>Finished back</li> <li>Bore and dowel drawer construction: black</li> <li>Cushion, if selected: Billiard</li> <li>Ledge pull: paint</li> <li>One fastened metal filing system per file drawer: black only</li> <li>Full extension, heavy-duty ball bearing drawer suspensions</li> <li>Counterweight</li> <li>Lock plug: polished chrome</li> <li>Lock cylinder included in package, field-installed</li> <li>Shipped fully assembled</li> </ul>	<ol style="list-style-type: none"> <li>Style number</li> <li>Low-Pressure Laminate color number for pedestal and headset</li> <li>Low-Pressure Laminate color number for top</li> <li>Plastic color number for edge</li> <li>Paint color number for pull</li> <li>Options, if selected (see below)</li> </ol> <p>▶ See <i>Surface Materials</i>, page 506.</p>

Options	U.S. Price	Required to Specify
<b>Keys</b> <ul style="list-style-type: none"> <li>Standard key plug</li> <li>Master key plug</li> </ul>	No cost +\$39	Specify with standard key plug. Specify with master key plug.

Specification Information				
Style Number	Dimensions			U.S. Base Price
	D	W	H	

## 1.5-High Mobile Pedestals

### One Box Drawer and One File Drawer

<b>AMQCRMP15H</b>	18 <sup>7</sup> / <sub>8</sub> "	15 <sup>3</sup> / <sub>4</sub> "	23 <sup>2</sup> / <sub>3</sub> "	\$ 909
	22"	15 <sup>3</sup> / <sub>4</sub> "	23 <sup>2</sup> / <sub>3</sub> "	\$ 978

## Two-High Mobile Pedestals

### Two Box Drawers and One File Drawer

<b>AMQCRMP2HBBF</b>	22"	15 <sup>3</sup> / <sub>4</sub> "	27"	\$1343
---------------------	-----	----------------------------------	-----	--------

### Two File Drawers

<b>AMQCRMP2HFF</b>	22"	15 <sup>3</sup> / <sub>4</sub> "	27"	\$1343
--------------------	-----	----------------------------------	-----	--------

## Pedestal Cushion Top

<b>AMQCRC</b>	22"	15 <sup>3</sup> / <sub>4</sub> "	1½"	\$ 461
---------------	-----	----------------------------------	-----	--------

# Lateral Files

One-High, 1.5-High, and Two-High

Standard Includes	Required to Specify
<ul style="list-style-type: none"> <li>Lateral file: Low-Pressure Laminate case with matching or contrasting Low-Pressure Laminate headset</li> <li>1" thick top, if selected: Low-Pressure Laminate</li> <li>Finished back</li> <li>Ledge pull: paint</li> <li>Bore and dowel laminate drawer construction: black only</li> <li>One fastened metal filing system per file drawer: black only</li> <li>Full extension, heavy-duty ball bearing drawer suspensions</li> <li>Counterweight</li> <li>Attachment hardware</li> <li>1 1/4" adjustable leveling glides</li> <li>Shipped fully assembled</li> </ul>	<ol style="list-style-type: none"> <li>Style number</li> <li>Low-Pressure Laminate color number for lateral file and headset</li> <li>Low-Pressure Laminate color number for top</li> <li>Plastic color number for edge</li> <li>Paint color number for pull</li> <li>Options, if selected (see below)</li> </ol> <p>▶ See <i>Surface Materials</i>, page 506.</p>

Options	U.S. Price	Required to Specify
<b>Top</b> <ul style="list-style-type: none"> <li>No top</li> <li>With top</li> </ul>	No cost Prices below	Specify <i>with no top</i> . Specify <i>with top</i> .
<b>Keys</b> <ul style="list-style-type: none"> <li>Standard key plug</li> <li>Master key plug</li> </ul>	No cost +\$39	Specify <i>with standard key plug</i> . Specify <i>with master key plug</i> .

Tip: If the master key plug is optioned, **AMQLOCK9201XF** must be specified separately to be included.

Specification Information					
Style Number	Dimensions D    W    H			U.S. Base Price	Option (Add \$ to Base Price)

## One-High Laterals

### One File Drawer

<b>AMQCRL1H</b>	24"	30"	15 3/8"	\$1140	+\$171
	24"	36"	15 3/8"	\$1200	+\$178

## 1.5-High Laterals

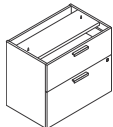
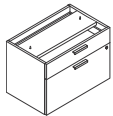
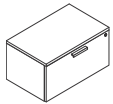
### One Box, One File Drawer

<b>AMQCRL15HBF</b>	24"	30"	21 3/8"	\$1483	+\$171
	24"	36"	21 3/8"	\$1560	+\$178

## Two-High Laterals

### Two File Drawers

<b>AMQCRL2H</b>	24"	30"	27 5/16"	\$1692	+\$171
	24"	36"	27 5/16"	\$1779	+\$178



**For Canadian Pricing**  
Multiply U.S. Price by the Canadian price factor.  
▶ See page 1 for details.

# Lateral Files

## Three-High and Four-High Lateral Files

Standard Includes	Required to Specify
<ul style="list-style-type: none"> <li>Lateral file: Low-Pressure Laminate case with matching or contrasting Low-Pressure Laminate headset</li> <li>1 1/8" thick top, if selected: Low-Pressure Laminate</li> <li>Finished back</li> <li>Ledge pull: paint</li> <li>Bore and dowel laminate drawer construction: black only</li> <li>One fastened metal filing system per file drawer: black only</li> <li>Full extension, heavy-duty ball bearing drawer suspensions</li> <li>Counterweight</li> <li>Attachment hardware</li> <li>1 1/4" adjustable leveling glides</li> <li>Shipped fully assembled</li> </ul>	<ol style="list-style-type: none"> <li>Style number</li> <li>Low-Pressure Laminate color number for pedestal and headset</li> <li>Low-Pressure Laminate color number for top</li> <li>Plastic color number for edge</li> <li>Paint color number for pull</li> <li>Options, if selected (see below)</li> </ol> <p>▶ See <i>Surface Materials</i>, page 506.</p>

Tip: If the master key plug is optioned, **AMQLOCK9201XF** must be specified separately to be included.

Options	U.S. Price	Required to Specify
<b>Keys</b> <ul style="list-style-type: none"> <li>Standard key plug</li> <li>Master key plug</li> </ul>	No cost +\$39	Specify with <i>standard key plug</i> . Specify with <i>master key plug</i> .

Specification Information				
Style Number	Dimensions			U.S. Base Price
	D	W	H	

### Three-High Laterals

<b>AMQCRL3H</b>	18 7/8"	30"	39 1/5"	\$2812
	18 7/8"	36"	39 1/5"	\$2973

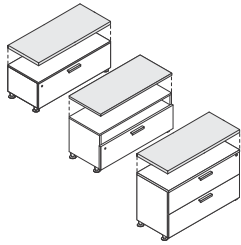
### Four-High Laterals

<b>AMQCRL4H</b>	18 7/8"	30"	51 1/5"	\$3086
	18 7/8"	36"	51 1/5"	\$3187



 **For Canadian Pricing**  
 Multiply U.S. Price by the Canadian price factor.  
 ▶ See page 1 for details.





*Tip: Cushion is constructed with a thin solid base.*

*Tip: Cushion is field-installed and supplies to attach are included.*

Standard Includes	Required to Specify
-------------------	---------------------

- Enhanced cushion top: Billiard fabric
- Attachment supplies: hook and loop fastener
- Storage brace

- 1 Style number
- 2 Fabric color number for cushion
- ▶ See *Surface Materials*, page 506.

Specification Information				
•Style Number	•Dimensions			•U.S. Price
	D	W	H	

AMQRCHE2430	23 1/8"	30"	1"	\$625
AMQRCHE2436	23 1/8"	36"	1"	\$643



 **For Canadian Pricing**  
 Multiply U.S. Price by the Canadian price factor.  
 ▶ See page 1 for details.

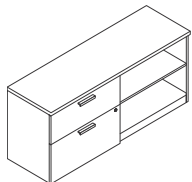
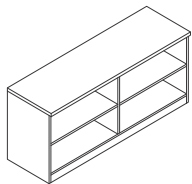
# Two-High Credenzas

Tip: Counterweight type and quantity varies depending on size and storage configuration. Please refer to the electronic catalog or SmartTools.

Tip: Top is not standard.

Tip: If the master key plug is optioned, **AMQLOCK9201XF** must be specified separately to be included.

Tip: Height is shown without top.



Left-hand unit

Standard Includes	Required to Specify
<ul style="list-style-type: none"> <li>Two-High credenza: Low-Pressure Laminate case with matching or contrasting Low-Pressure Laminate headset</li> <li>1 1/8" thick top: Low-Pressure Laminate</li> <li>Adjustable shelf on open storage configuration and cabinet storage configuration</li> <li>Finished back</li> <li>Ledge pull: paint</li> <li>Lock plug: polished chrome</li> <li>Lock cylinder included in package, field-installed</li> <li>Counterweight included on units with drawers</li> <li>1 1/4" adjustable leveling glides</li> <li>Shipped fully assembled</li> </ul>	<ol style="list-style-type: none"> <li>Style number</li> <li>Low-Pressure Laminate color number for pedestal and headset</li> <li>Low-Pressure Laminate color number for top</li> <li>Plastic color number for edge</li> <li>Paint color number for pull</li> <li>Options, if selected (see below)</li> </ol> <p>▶ See <i>Surface Materials</i>, page 506.</p>

Options	U.S. Price	Required to Specify
<b>Top</b> <ul style="list-style-type: none"> <li>No top</li> <li>With top</li> </ul>	No cost Prices below	Specify <i>with no top</i> . Specify <i>with top</i> .
<b>Keys</b> <ul style="list-style-type: none"> <li>Standard key plug</li> <li>Master key plug</li> </ul>	No cost +\$39	Specify <i>with standard key plug</i> . Specify <i>with master key plug</i> .

Specification Information					
Style Number	Dimensions			U.S. Base Price	Option (Add \$ to Base Price)
	D	W	H		
					Top

## Open/Open File Configuration

<b>AMQCRC2HFSOO</b>	24"	60"	27 <sup>5</sup> / <sub>16</sub> "	\$1631	+\$254
	24"	66"	27 <sup>5</sup> / <sub>16</sub> "	\$1716	+\$287
	24"	72"	27 <sup>5</sup> / <sub>16</sub> "	\$1805	+\$320

## Left Lateral/Open File Configuration

<b>AMQCRC2HFSLFL</b>	24"	60"	27 <sup>5</sup> / <sub>16</sub> "	\$2175	+\$254
	24"	66"	27 <sup>5</sup> / <sub>16</sub> "	\$2277	+\$287
	24"	72"	27 <sup>5</sup> / <sub>16</sub> "	\$2387	+\$320

## Right Lateral/Open File Configuration

<b>AMQCRC2HFSLFR</b>	24"	60"	27 <sup>5</sup> / <sub>16</sub> "	\$2175	+\$254
	24"	66"	27 <sup>5</sup> / <sub>16</sub> "	\$2277	+\$287
	24"	72"	27 <sup>5</sup> / <sub>16</sub> "	\$2387	+\$320

▶ Specification Information, continued on next page



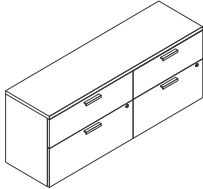
**For Canadian Pricing**  
Multiply U.S. Price by the Canadian price factor.  
▶ See page 1 for details.

► Specification Information, continued from previous page

**Specification Information**

Tip: Height is shown without top.

Style Number	Dimensions			U.S. Base Price	Option (Add \$ to Base Price)
	D	W	H		
					Top

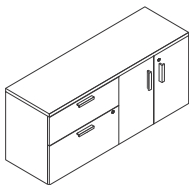


**Lateral/Lateral File Configuration**

AMQCRCD2HFSL	24"	60"	27 <sup>5</sup> / <sub>16</sub> "	\$2822	+\$254
	24"	66"	27 <sup>5</sup> / <sub>16</sub> "	\$2947	+\$287
	24"	72"	27 <sup>5</sup> / <sub>16</sub> "	\$3078	+\$320

**Right Lateral/Cabinet File Configuration**

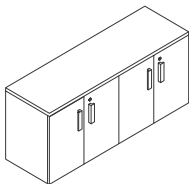
AMQCRCD2HFSLCLFL	24"	60"	27 <sup>5</sup> / <sub>16</sub> "	\$2277	+\$254
	24"	66"	27 <sup>5</sup> / <sub>16</sub> "	\$2387	+\$287
	24"	72"	27 <sup>5</sup> / <sub>16</sub> "	\$2501	+\$320



Left-hand unit

**Left Lateral/Cabinet File Configuration**

AMQCRCD2HFSLCLFR	24"	60"	27 <sup>5</sup> / <sub>16</sub> "	\$2277	+\$254
	24"	66"	27 <sup>5</sup> / <sub>16</sub> "	\$2387	+\$287
	24"	72"	27 <sup>5</sup> / <sub>16</sub> "	\$2501	+\$320



**Cabinet/Cabinet File Configuration**

AMQCRCD2HFSCC	24"	60"	27 <sup>5</sup> / <sub>16</sub> "	\$1794	+\$254
	24"	66"	27 <sup>5</sup> / <sub>16</sub> "	\$1886	+\$287
	24"	72"	27 <sup>5</sup> / <sub>16</sub> "	\$1987	+\$320

 **For Canadian Pricing**  
 Multiply U.S. Price by the Canadian price factor.  
 ► See page 1 for details.

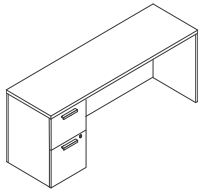
# Two-High Credenzas

Tip: Counterweight type and quantity varies depending on size and storage configuration. Please refer to the electronic catalog or SmartTools.

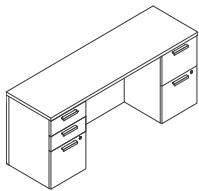
Tip: Grain direction of modesty panel runs horizontally. Grain direction of pedestals runs vertically.

Tip: Pedestals can be specified as a file/file or box/box/file configurations.

Tip: If the master key plug is optioned, **AMQLOCK9201XF** must be specified separately to be included.



Left-hand unit



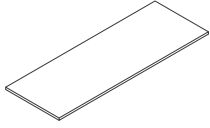
Standard Includes	Required to Specify
<ul style="list-style-type: none"> <li>Two-High credenza with kneespace Low-Pressure Laminate case with matching or contrasting Low-Pressure Laminate headset</li> <li>1 1/8" thick top: Low-Pressure Laminate</li> <li>Finished back</li> <li>Modesty panel</li> <li>Edge pull: paint</li> <li>Bore and dowel drawer construction: black</li> <li>One fastened metal filing system per file drawer: black only</li> <li>Full extension, heavy-duty ball bearing drawer suspensions</li> <li>One pencil tray is included in units with a box drawer</li> <li>Lock cylinder included in package, field-installed</li> <li>Lock plug: polished chrome</li> <li>Counterweight</li> <li>1 1/4" adjustable leveling glides</li> <li>Shipped fully assembled</li> </ul>	<ol style="list-style-type: none"> <li>Style number</li> <li>Low-Pressure Laminate color number for pedestal and headset</li> <li>Low-Pressure Laminate color number for top</li> <li>Plastic color number for edge</li> <li>Paint color number for pull</li> <li>Options, if selected (see below)</li> </ol> <p>▶ See <i>Surface Materials</i>, page 506.</p>

Options	U.S. Price	Required to Specify
<b>Modesty Panel</b> <ul style="list-style-type: none"> <li>Full</li> <li>Quarter height</li> </ul>	No cost No cost	Specify with full modesty panel. Specify with quarter height modesty panel.
<b>Right Support</b> <ul style="list-style-type: none"> <li>Box/box/file pedestal</li> <li>File/file pedestal</li> </ul>	No cost No cost	Specify with box/box/file pedestal. Specify with file/file pedestal.
<b>Left Support</b> <ul style="list-style-type: none"> <li>Box/box/file pedestal</li> <li>File/file pedestal</li> </ul>	No cost No cost	Specify with box/box/file pedestal. Specify with file/file pedestal.
<b>Keys</b> <ul style="list-style-type: none"> <li>Standard key plug</li> <li>Master key plug</li> </ul>	No cost +\$39	Specify with standard key plug. Specify with master key plug.

Specification Information				
Style Number	Dimensions			U.S. Base Price
	D	W	H	
<b>Left Pedestal Configuration</b>				
<b>AMQCRC2HKSSPL</b>	24"	66"	28 7/16"	\$2050
	24"	72"	28 7/16"	\$2180
<b>Right Pedestal Configuration</b>				
<b>AMQCRC2HKSSPR</b>	24"	66"	28 7/16"	\$2050
	24"	72"	28 7/16"	\$2180
<b>Double Pedestal Configuration</b>				
<b>AMQCRC2HKSDP</b>	24"	66"	28 7/16"	\$2643
	24"	72"	28 7/16"	\$2801



**For Canadian Pricing**  
 Multiply U.S. Price by the Canadian price factor.  
 ▶ See page 1 for details.



Standard Includes	Required to Specify
<ul style="list-style-type: none"> <li>• 1 1/8" thick top: Low-Pressure Laminate</li> <li>• 3 mm edgeband on user's side: plastic</li> <li>• 1 mm edgeband on sides and back: plastic</li> </ul>	<ul style="list-style-type: none"> <li>1 Style number</li> <li>2 Low-Pressure Laminate color number for pedestal and headset</li> <li>3 Low-Pressure Laminate color number for top</li> </ul> <p>▶ See <i>Surface Materials</i>, page 506.</p>

### Specification Information

• Style Number	• Dimensions Modular Depth	• U.S. Prices Modular Width							
		45.6875"	51.6875"	59.75"	65.75"	71.75"	89.5625"	89.8125"	95.8125"
<b>AMQCRCT</b>	18 7/8"	\$185	\$224	\$238	\$257	\$301	\$450	\$450	\$479
	24"	\$200	\$238	\$255	\$270	\$304	\$503	\$503	\$520
	30"	\$270	\$307	\$329	\$351	\$382	\$562	\$562	\$586



**For Canadian Pricing**  
 Multiply U.S. Price by the Canadian price factor.  
 ▶ See page 1 for details.

# Desks and Desk Shells

*Tip: Counterweight type and quantity varies depending on size and storage configuration. Please refer to the electronic catalog or SmartTools.*

*Tip: Pedestals can be specified as a file/file or box/box/file configuration.*

Standard Includes	Required to Specify
<ul style="list-style-type: none"> <li>• Desk and desk shells with pedestal, if specified: Low-Pressure Laminate case with matching or contrasting Low-Pressure Laminate headset</li> <li>• 1 1/8" thick top: Low-Pressure Laminate</li> <li>• 3 mm radius profile edge on user's side: plastic</li> <li>• 1 mm edgeband on sides and back: plastic</li> <li>• Finished back</li> <li>• Modesty panel</li> <li>• Ledge pull: paint</li> <li>• Bore and dowel drawer construction: black</li> <li>• One fastened metal filing system per file drawer: black only</li> <li>• Full extension, heavy-duty ball bearing drawer suspensions</li> <li>• Lock plug</li> <li>• Lock cylinder included in package, field-installed</li> <li>• Counterweight</li> <li>• 1 1/4" adjustable leveling glides</li> <li>• Desk shells shipped ready to assemble</li> <li>• Desk with pedestal(s) shipped fully assembled</li> <li>• One pencil tray is included in units with a box drawer</li> </ul>	<ol style="list-style-type: none"> <li>1 Style number</li> <li>2 Low-Pressure Laminate color number for case</li> <li>3 Low-Pressure Laminate color number for top</li> <li>4 Paint color number for pull</li> <li>5 Options, if selected (see below)</li> </ol> <p>▶ See <i>Surface Materials</i>, page 506.</p>

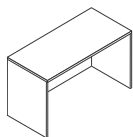
Options	U.S. Price	Required to Specify
<b>Modesty Panel</b> <ul style="list-style-type: none"> <li>• Full</li> <li>• Quarter height</li> </ul>	No cost No cost	Specify with <i>full modesty panel</i> . Specify with <i>quarter height modesty panel</i> .
<b>Keys</b> <ul style="list-style-type: none"> <li>• Standard key plug</li> <li>• Master key plug</li> </ul>	No cost +\$39	Specify with <i>standard key plug</i> . Specify with <i>master key plug</i> .

*Tip: If the master key plug is optioned, **AMQLOCK9201XF** must be specified separately to be included.*

Specification Information				
Style Number	Dimensions			U.S. Base Price
	D	W	H	

Desk Shell with Two Full Depth End Panels				
Style Number	D	W	H	U.S. Base Price
AMQCRDSSL	24"	60"	28 7/16"	\$ 858
	24"	66"	28 7/16"	\$ 900
	24"	72"	28 7/16"	\$ 931
	30"	60"	28 7/16"	\$ 907
	30"	66"	28 7/16"	\$ 947
	30"	72"	28 7/16"	\$ 984
	36"	72"	28 7/16"	\$1223

▶ **Specification Information, continued on next page**



 **For Canadian Pricing**  
 Multiply U.S. Price by the Canadian price factor.  
 ▶ See page 1 for details.

## ► Specification Information, continued from previous page

**Specification Information**

Style Number	Dimensions			U.S. Base Price
	D	W	H	

**Desk with One Full Depth End Panel and Left-Hand Pedestal**

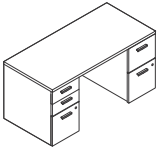
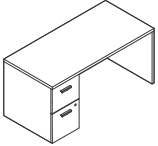
<b>AMQCRDSKSPL</b>	30"	60"	28 <sup>7</sup> / <sub>16</sub> "	\$1978
	30"	66"	28 <sup>7</sup> / <sub>16</sub> "	\$2089
	30"	72"	28 <sup>7</sup> / <sub>16</sub> "	\$2196
	36"	72"	28 <sup>7</sup> / <sub>16</sub> "	\$2299

**Desk with One Full Depth End Panel and Right-Hand Pedestal**

<b>AMQCRDSKSPR</b>	30"	60"	28 <sup>7</sup> / <sub>16</sub> "	\$1978
	30"	66"	28 <sup>7</sup> / <sub>16</sub> "	\$2089
	30"	72"	28 <sup>7</sup> / <sub>16</sub> "	\$2196
	36"	72"	28 <sup>7</sup> / <sub>16</sub> "	\$2299

**Desk with Two Pedestals**

<b>AMQCRDSKDP</b>	30"	60"	28 <sup>7</sup> / <sub>16</sub> "	\$2686
	30"	66"	28 <sup>7</sup> / <sub>16</sub> "	\$2822
	30"	72"	28 <sup>7</sup> / <sub>16</sub> "	\$2954
	36"	72"	28 <sup>7</sup> / <sub>16</sub> "	\$3085

**For Canadian Pricing**

Multiply U.S. Price by the Canadian price factor.

► See page 1 for details.

# Returns and Return Shells

Tip: Counterweight type and quantity varies depending on size and storage configuration. Please refer to the electronic catalog or SmartTools.

Standard Includes	Required to Specify
<ul style="list-style-type: none"> <li>Return and return shells: Low-Pressure Laminate case with matching or contrasting Low-Pressure Laminate headset</li> <li>1 1/8" thick top: Low-Pressure Laminate</li> <li>3 mm radius profile edge on user's side: plastic</li> <li>1 mm edgeband on sides and back: plastic</li> <li>Finished back</li> <li>Modesty panel</li> <li>Ledge pull: paint</li> <li>Bore and dowel drawer construction: black</li> <li>One fastened metal filing system per file drawer: black only</li> <li>Full extension, heavy-duty ball bearing drawer suspensions</li> <li>Lock plug</li> <li>Lock cylinder included in package, field-installed</li> <li>Counterweight</li> <li>1 1/4" adjustable leveling glides</li> <li>Returns shipped fully assembled</li> <li>Return shells shipped ready to assemble</li> </ul>	<ol style="list-style-type: none"> <li>Style number</li> <li>Low-Pressure Laminate color number for returns</li> <li>Low-Pressure Laminate color number for top</li> <li>Paint color number for pull</li> <li>Options, if selected (see below)</li> </ol> <p>▶ See <i>Surface Materials</i>, page 506.</p>

Options	U.S. Price	Required to Specify
<b>Modesty Panel</b> <ul style="list-style-type: none"> <li>Full</li> <li>Quarter height</li> </ul>	No cost No cost	Specify with full modesty panel. Specify with quarter height modesty panel.
<b>Keys</b> <ul style="list-style-type: none"> <li>Standard key plug</li> <li>Master key plug</li> </ul>	No cost +\$39	Specify with standard key plug. Specify with master key plug.

Tip: If the master key plug is optioned, **AMQLOCK9201XF** must be specified separately to be included.

Specification Information				
Style Number	Dimensions			U.S. Base Price
	D	W	H	

### Return Shell with One Left-Hand Full Depth End Panel

<b>AMQCRRTNL</b>	24"	42"	287/16"	\$ 687
	24"	48"	287/16"	\$ 749

### Return Shell with One Right-Hand Full Depth End Panel

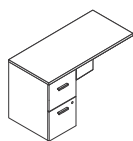
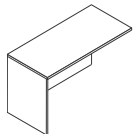
<b>AMQCRRTNR</b>	24"	42"	287/16"	\$ 687
	24"	48"	287/16"	\$ 749

### Return Shell with One Left-Hand Pedestal

<b>AMQCRRTNSPL</b>	24"	42"	287/16"	\$1423
	24"	48"	287/16"	\$1557

### Return Shell with One Right-Hand Pedestal

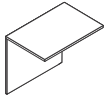
<b>AMQCRRTNSPR</b>	24"	42"	287/16"	\$1423
	24"	48"	287/16"	\$1557



Left-hand unit

Tip: Pedestals can be specified as a file/file or box/box/file configurations.

 **For Canadian Pricing**  
 Multiply U.S. Price by the Canadian price factor.  
 ▶ See page 1 for details.



Standard Includes	Required to Specify
<ul style="list-style-type: none"> <li>• 24"D bridge: Low-Pressure Laminate</li> <li>• 1" thick top, if selected: Low-Pressure Laminate</li> <li>• Attachment bracket</li> <li>• 3 mm edgeband on user's side: plastic</li> <li>• 1 mm edgeband on sides and back: plastic</li> <li>• Modesty panel</li> <li>• Ships ready to assemble</li> </ul>	<ul style="list-style-type: none"> <li>1 Style number</li> <li>2 Low-Pressure Laminate color number for bridge</li> <li>3 Plastic color number for edge</li> <li>4 Options, if selected (see below)</li> <li>▶ See <i>Surface Materials</i>, page 506.</li> </ul>

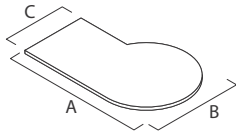
Options	U.S. Price	Required to Specify
<b>Modesty Panel</b> <ul style="list-style-type: none"> <li>• Full</li> <li>• Quarter height</li> </ul>	<ul style="list-style-type: none"> <li>No cost</li> <li>No cost</li> </ul>	<ul style="list-style-type: none"> <li>Specify with <i>full modesty panel</i>.</li> <li>Specify with <i>quarter height modesty panel</i>.</li> </ul>

Specification Information				
Style Number	Dimensions			U.S. Price
	D	W	H	
<b>AMQCRBRG</b>	24"	36"	27 <sup>5</sup> / <sub>12</sub> "	\$506
	24"	42"	27 <sup>5</sup> / <sub>12</sub> "	\$538
	24"	48"	27 <sup>5</sup> / <sub>12</sub> "	\$578



 **For Canadian Pricing**  
 Multiply U.S. Price by the Canadian price factor.  
 ▶ See page 1 for details.

# D-Shape and P-Shape Worksurfaces



Right-hand unit

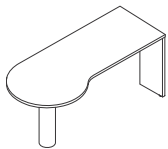
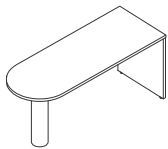
Tip: Width and depth is specified for the D-shape top.

Tip: D-shape and P-shape worksurfaces with column leg are not freestanding units.

They must be attached to a bridge, return, or adjoining worksurface to form a flush-height, L-, or U-shaped configuration for proper stability.

Tip: Width A, depth B, and depth C is specified for the P-shape top.

Tip: Right-hand P-shape worksurfaces pair with left-hand returns. Left-hand P-shape worksurfaces pair with right-hand returns.



Right-hand unit

Standard Includes	Required to Specify
<ul style="list-style-type: none"> <li>1 1/8" thick worksurface: Low-Pressure Laminate case with matching or contrasting Low-Pressure Laminate top</li> <li>Column leg: paint price group 1</li> <li>Adjusting leveling glides</li> <li>Ships ready to assemble</li> </ul>	<ol style="list-style-type: none"> <li>Style number</li> <li>Low-Pressure Laminate color number for worksurface and case</li> <li>Plastic color number for edge</li> <li>Paint color number for column</li> <li>Options, if selected (see below)</li> </ol> <p>▶ See <i>Surface Materials</i>, page 506.</p>

Options	U.S. Price	Required to Specify
<b>Surface Materials</b> <ul style="list-style-type: none"> <li>Base</li> <li>Paint price group 1</li> <li>Paint price group 2</li> </ul>	No cost +\$ 27	Specify paint color number. Specify paint color number.
<b>Modesty Panel</b> <ul style="list-style-type: none"> <li>No modesty panel</li> <li>Quarter height</li> <li>Full</li> </ul>	No cost +\$175 +\$309	Specify with no modesty panel. Specify with quarter height modesty panel. Specify with full modesty panel.
<b>Width A</b> <ul style="list-style-type: none"> <li>60"</li> <li>66"</li> <li>72"</li> </ul>	Price below Price below Price below	Specify with 60" width A. Specify with 66" width A. Specify with 72" width A.
<b>Depth B</b> <ul style="list-style-type: none"> <li>30"</li> <li>36"</li> <li>42"</li> </ul>	Price below Price below Price below	Specify with 30" depth B. Specify with 36" depth B. Specify with 42" depth B.
<b>Depth C</b> <ul style="list-style-type: none"> <li>24"</li> <li>30"</li> <li>36"</li> </ul>	Price below Price below Price below	Specify with 24" depth C. Specify with 30" depth C. Specify with 36" depth C.
<b>Handedness</b> <ul style="list-style-type: none"> <li>Left hand</li> <li>Right hand</li> </ul>	No cost No cost	Specify with left hand. Specify with right hand.

Specification Information		
Style Number	Dimensions Modular Depth	U.S. Base Prices
		Modular Width
		60"W : 66"W : 72"W

## D-Shape, Low-Pressure Laminate Case and Top

AMQCRDWKSF	30"	\$1238	\$1315	\$1385
	36"	\$1361	\$1438	\$1551

## P-Shape, Low-Pressure Laminate Case and Top

AMQCRPWKSF	24"	\$1420	\$1572	\$1800
	30"	\$1494	\$1654	\$1893
	36"	\$1570	\$1737	\$1989



**For Canadian Pricing**  
Multiply U.S. Price by the Canadian price factor.  
▶ See page 1 for details.

# Towers

## Single Door

Tip: Nominal dimensions shown in specifying. Please refer to understanding pages for actual dimensions.

Tip: If the master key plug is optioned, **AMQLOCK9201XF** must be specified separately to be included.



 **For Canadian Pricing**  
Multiply U.S. Price by the Canadian price factor.  
▶ See page 1 for details.

Standard Includes	Required to Specify
<ul style="list-style-type: none"> <li>• Single-door tower: Low-Pressure Laminate case with matching or contrasting Low-Pressure Laminate headset</li> <li>• 3/4" thick top: laminate to match case</li> <li>• Ledge pull: paint</li> <li>• Lock plug</li> <li>• Lock cylinder included in package, field-installed</li> <li>• Counterweights</li> <li>• 1 1/4" leveling glides</li> <li>• Shipped fully assembled</li> <li>• Bore and dowel drawer construction: black</li> </ul>	<ol style="list-style-type: none"> <li>1 Style number</li> <li>2 Low-Pressure Laminate color number for tower</li> <li>3 Paint color number for pull</li> <li>4 Options, if selected (see below)</li> </ol> <p>▶ See <i>Surface Materials</i>, page 506.</p>

Options	U.S. Price	Required to Specify
<b>Keys</b> <ul style="list-style-type: none"> <li>• Standard key plug</li> <li>• Master key plug</li> </ul>	No cost +\$39	Specify with <i>standard key plug</i> . Specify with <i>master key plug</i> .

Specification Information				
Style Number	Dimensions D W H			U.S. Base Price

Single Left-Hinged Door Tower with One Box Drawer and One File Drawer				
<b>AMQCRTWBFL</b>	24"	15 3/4"	41 25/32"	\$2135
	24"	15 3/4"	47 31/32"	\$2232
	24"	15 3/4"	54 1/8"	\$2339
	24"	15 3/4"	66 1/2"	\$2450

Single Right-Hinged Door Tower with One Box Drawer and One File Drawer				
<b>AMQCRTWBFR</b>	24"	15 3/4"	41 25/32"	\$2135
	24"	15 3/4"	47 31/32"	\$2232
	24"	15 3/4"	54 1/8"	\$2339
	24"	15 3/4"	66 1/2"	\$2450

Single Left-Hinged Door Tower with Two File Drawers				
<b>AMQCRTWFFL</b>	24"	15 3/4"	41 25/32"	\$2213
	24"	15 3/4"	47 31/32"	\$2317
	24"	15 3/4"	54 1/8"	\$2428
	24"	15 3/4"	66 1/2"	\$2543

Single Right-Hinged Door Tower with Two File Drawers				
<b>AMQCRTWFFR</b>	24"	15 3/4"	41 25/32"	\$2213
	24"	15 3/4"	47 31/32"	\$2317
	24"	15 3/4"	54 1/8"	\$2428
	24"	15 3/4"	66 1/2"	\$2543



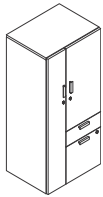
# Towers

## Dual Doors

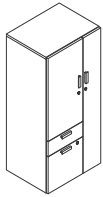
Tip: Nominal dimensions shown in specifying. Please refer to understanding pages for actual dimensions.

Tip: Handedness determines the location of the wardrobe.

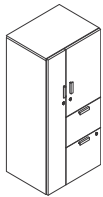
Tip: If the master key plug is optioned, **AMQLOCK9201XF** must be specified separately to be included.



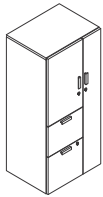
Left-hand unit



Right-hand unit



Left-hand unit



Right-hand unit

Standard Includes	Required to Specify
<ul style="list-style-type: none"> <li>Dual-door tower: Low-Pressure Laminate case with matching or contrasting Low-Pressure Laminate headset</li> <li>3/4" thick top: laminate to match case</li> <li>Coat hook: brushed nickel only</li> <li>Ledge pull: paint</li> <li>Lock plug</li> <li>Lock cylinder included in package, field-installed</li> <li>Counterweights</li> <li>1 1/4" leveling glides</li> <li>Shipped fully assembled</li> <li>Bore and dowel drawer construction: black</li> </ul>	<ol style="list-style-type: none"> <li>Style number</li> <li>Low-Pressure Laminate color number for tower</li> <li>Paint color number for pull</li> <li>Options, if selected (see below)</li> </ol> <p>▶ See <i>Surface Materials</i>, page 506.</p>

Options	U.S. Price	Required to Specify
<b>Keys</b> <ul style="list-style-type: none"> <li>Standard key plug</li> <li>Master key plug</li> </ul>	No cost +\$39	Specify with standard key plug. Specify with master key plug.

Specification Information				
Style Number	Dimensions			U.S. Base Price
	D	W	H	

### Dual Left-Hand Door Tower with One Box Drawer and One File Drawer, Wardrobe Left

<b>AMQCRTWDBFL</b>	24"	24"	41 <sup>25</sup> / <sub>32</sub> "	\$2270
	24"	24"	47 <sup>31</sup> / <sub>32</sub> "	\$2378
	24"	24"	54 <sup>1</sup> / <sub>8</sub> "	\$2648
	24"	24"	66 <sup>1</sup> / <sub>2</sub> "	\$2890

### Dual Right-Hand Door Tower with One Box Drawer and One File Drawer, Wardrobe Right

<b>AMQCRTWDBFR</b>	24"	24"	41 <sup>25</sup> / <sub>32</sub> "	\$2270
	24"	24"	47 <sup>31</sup> / <sub>32</sub> "	\$2378
	24"	24"	54 <sup>1</sup> / <sub>8</sub> "	\$2648
	24"	24"	66 <sup>1</sup> / <sub>2</sub> "	\$2890

### Dual Left-Hinged Door Tower with Two File Drawers, Wardrobe Left

<b>AMQCRTWDFFL</b>	24"	15 <sup>3</sup> / <sub>4</sub> "	41 <sup>25</sup> / <sub>32</sub> "	\$2356
	24"	15 <sup>3</sup> / <sub>4</sub> "	47 <sup>31</sup> / <sub>32</sub> "	\$2469
	24"	15 <sup>3</sup> / <sub>4</sub> "	54 <sup>1</sup> / <sub>8</sub> "	\$2750
	24"	15 <sup>3</sup> / <sub>4</sub> "	66 <sup>1</sup> / <sub>2</sub> "	\$3000

### Dual Right-Hinged Door Tower with Two File Drawers, Wardrobe Right

<b>AMQCRTWDFFR</b>	24"	15 <sup>3</sup> / <sub>4</sub> "	41 <sup>25</sup> / <sub>32</sub> "	\$2356
	24"	15 <sup>3</sup> / <sub>4</sub> "	47 <sup>31</sup> / <sub>32</sub> "	\$2469
	24"	15 <sup>3</sup> / <sub>4</sub> "	54 <sup>1</sup> / <sub>8</sub> "	\$2750
	24"	15 <sup>3</sup> / <sub>4</sub> "	66 <sup>1</sup> / <sub>2</sub> "	\$3000

# Towers

## Side Access

Tip: Nominal dimensions shown in specifying. Please refer to understanding pages for actual dimensions.

Tip: If the master key plug is optioned, **AMQLOCK9201XF** must be specified separately to be included.



Left-hand unit



Right-hand unit



Left-hand unit



Right-hand unit

Standard Includes	Required to Specify
<ul style="list-style-type: none"> <li>Dual-door tower: Low-Pressure Laminate case with matching or contrasting Low-Pressure Laminate headset</li> <li>3/4" thick top: laminate to match case</li> <li>Ledge pull: paint</li> <li>Coat hook: brushed nickel only</li> <li>Lock plug</li> <li>Lock cylinder included in package, field-installed</li> <li>Counterweights</li> <li>1 1/4" leveling glides</li> <li>Shipped fully assembled</li> <li>Bore and dowel drawer construction: black</li> </ul>	<ol style="list-style-type: none"> <li>Style number</li> <li>Low-Pressure Laminate color number for tower</li> <li>Paint color number for pull</li> <li>Options, if selected (see below)</li> </ol> <p>▶ See <i>Surface Materials</i>, page 506.</p>

Options	U.S. Price	Required to Specify
<b>Keys</b> <ul style="list-style-type: none"> <li>Standard key plug</li> <li>Master key plug</li> </ul>	No cost +\$39	Specify with <i>standard key plug</i> . Specify with <i>master key plug</i> .

Specification Information				
Style Number	Dimensions			U.S. Base Price
	D	W	H	

### Side Access Left-Hand Tower with Two Box Drawers and One File Drawer

<b>AMQCRTWSABBFL</b>	24"	24"	41 <sup>25</sup> / <sub>32</sub> "	\$2453
	24"	24"	47 <sup>31</sup> / <sub>32</sub> "	\$2568
	24"	24"	54 <sup>1</sup> / <sub>8</sub> "	\$2692
	24"	24"	66 <sup>1</sup> / <sub>2</sub> "	\$2822

### Side Access Right-Hand Tower with Two Box Drawers/One File Drawer

<b>AMQCRTWSABBFR</b>	24"	24"	41 <sup>25</sup> / <sub>32</sub> "	\$2453
	24"	24"	47 <sup>31</sup> / <sub>32</sub> "	\$2568
	24"	24"	54 <sup>1</sup> / <sub>8</sub> "	\$2692
	24"	24"	66 <sup>1</sup> / <sub>2</sub> "	\$2822

### Side Access Left-Hand Tower with Two File Drawers

<b>AMQCRTWSAFFL</b>	24"	24"	41 <sup>25</sup> / <sub>32</sub> "	\$2364
	24"	24"	47 <sup>31</sup> / <sub>32</sub> "	\$2479
	24"	24"	54 <sup>1</sup> / <sub>8</sub> "	\$2597
	24"	24"	66 <sup>1</sup> / <sub>2</sub> "	\$2721

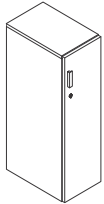
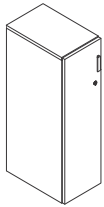
### Side Access Right-Hand Tower with Two File Drawers

<b>AMQCRTWSAFFR</b>	24"	24"	41 <sup>25</sup> / <sub>32</sub> "	\$2364
	24"	24"	47 <sup>31</sup> / <sub>32</sub> "	\$2479
	24"	24"	54 <sup>1</sup> / <sub>8</sub> "	\$2597
	24"	24"	66 <sup>1</sup> / <sub>2</sub> "	\$2721

# Wardrobes

*Tip: Wardrobe must be attached to two additional wardrobes, another storage unit, or a wall to ensure stability and prevent wardrobe from tipping.*

*Tip: If the master key plug is optioned, **AMQLOCK9201XF** must be specified separately to be included.*



Standard Includes	Required to Specify
<ul style="list-style-type: none"> <li>• Wardrobe: Low-Pressure Laminate case with matching or contrasting Low-Pressure Laminate headset</li> <li>• 3/4" thick top: laminate to match case</li> <li>• Ledge pull: paint</li> <li>• Coat hook: brushed nickel only</li> <li>• Lock plug</li> <li>• 1 1/4" leveling glides</li> <li>• Lock cylinder included in package, field-installed</li> <li>• Shipped fully assembled</li> </ul>	<ol style="list-style-type: none"> <li>1 Style number</li> <li>2 Low-Pressure Laminate color number for tower</li> <li>3 Paint color number for pull</li> <li>4 Options, if selected (see below)</li> </ol> <p>▶ See <i>Surface Materials</i>, page 506.</p>

Options	U.S. Price	Required to Specify
<b>Keys</b> <ul style="list-style-type: none"> <li>• Standard key plug</li> <li>• Master key plug</li> </ul>	No cost +\$39	Specify <i>with standard key plug</i> . Specify <i>with master key plug</i> .

## Specification Information

Style Number	Dimensions D    W    H			U.S. Base Price
--------------	---------------------------	--	--	-----------------

### Wardrobes-Hinged Left

<b>AMQCRWDL</b>	24"	12"	41 <sup>25</sup> / <sub>32</sub> "	\$1369
	24"	12"	47 <sup>31</sup> / <sub>32</sub> "	\$1406
	24"	12"	54 <sup>1</sup> / <sub>8</sub> "	\$1442

### Wardrobes-Hinged Right

<b>AMQCRWDR</b>	24"	12"	41 <sup>25</sup> / <sub>32</sub> "	\$1369
	24"	12"	47 <sup>31</sup> / <sub>32</sub> "	\$1406
	24"	12"	54 <sup>1</sup> / <sub>8</sub> "	\$1442



**For Canadian Pricing**  
Multiply U.S. Price by the Canadian price factor.  
▶ See page 1 for details.

# Bookcases with Adjustable Shelves

Bookcases with Adjustable Shelves

## Standard Includes

- Bookcase: Low-Pressure Laminate
- 1" thick table top: laminate to match case
- Adjustable shelf: laminate to match case
- Brackets for shelves: brushed nickel only
- 1/4" leveling glides
- Shipped fully assembled

## Required to Specify

- 1 Style number
- 2 Low-Pressure Laminate color number for bookcase
- ▶ See *Surface Materials*, page 506.

## Specification Information

Style Number	Dimensions			U.S. Price
	D	W	H	

### Two Adjustable Shelves

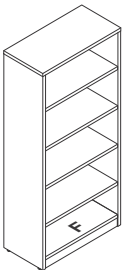
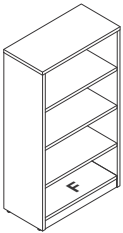
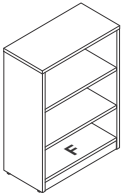
AMQCRBK	15"	30"	41 <sup>25</sup> / <sub>32</sub> "	\$1165
	15"	36"	41 <sup>25</sup> / <sub>32</sub> "	\$1187
	15"	30"	47 <sup>31</sup> / <sub>32</sub> "	\$1212
	15"	36"	47 <sup>31</sup> / <sub>32</sub> "	\$1235

### Three Adjustable Shelves

AMQCRBK	15"	30"	54 <sup>1</sup> / <sub>8</sub> "	\$1263
	15"	36"	54 <sup>1</sup> / <sub>8</sub> "	\$1287

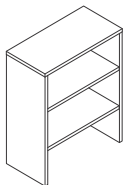
### Four Adjustable Shelves

AMQCRBK	15"	30"	66 <sup>1</sup> / <sub>2</sub> "	\$1316
	15"	36"	66 <sup>1</sup> / <sub>2</sub> "	\$1341
	15"	30"	72 <sup>11</sup> / <sub>16</sub> "	\$1480
	15"	36"	72 <sup>11</sup> / <sub>16</sub> "	\$1510



**For Canadian Pricing**  
Multiply U.S. Price by the Canadian price factor.  
▶ See page 1 for details.

# Stacking Bookcase with Adjustable Shelves



Standard Includes	Required to Specify
<ul style="list-style-type: none"> <li>Stacking bookcase: Low-Pressure Laminate</li> <li>1" thick table top: laminate to match case</li> <li>Adjustable shelf: laminate to match case</li> <li>Attachment hardware</li> <li>Shipped fully assembled</li> </ul>	<ul style="list-style-type: none"> <li>1 Style number</li> <li>2 Low-Pressure Laminate color number for bookcase</li> <li>▶ See <i>Surface Materials</i>, page 506.</li> </ul>

Specification Information				
• Style • Number	• Dimensions			• U.S. • Price
	• D	• W	• H	
<b>AMQCRBKS</b>	15"	30"	25 <sup>5</sup> / <sub>8</sub> "	\$ 915
	15"	30"	37 <sup>3</sup> / <sub>32</sub> "	\$ 953
	15"	30"	44 <sup>3</sup> / <sub>16</sub> "	\$1017
	15"	36"	25 <sup>5</sup> / <sub>8</sub> "	\$ 934
	15"	36"	37 <sup>3</sup> / <sub>32</sub> "	\$ 970
	15"	36"	44 <sup>3</sup> / <sub>16</sub> "	\$1039

 **For Canadian Pricing**  
 Multiply U.S. Price by the Canadian price factor.  
 ▶ See page 1 for details.

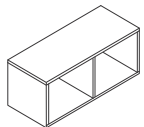
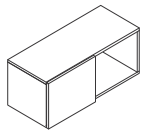
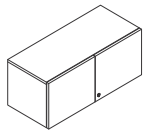
*Tip: Handedness is determined while in the seated position.*

*Tip: Overheads with sliding doors do not lock.*

*Tip: Overheads with three doors will have two doors hinged right. Overheads with four doors will have two doors hinged left, and two hinged right. Doors will always open from the center out.*

*Tip: White markerboard (2977) headset finish available with sliding doors only.*

*Tip: If the master key plug is optioned, **AMQLOCK9201XF** must be specified separately to be included.*



*Pricing at right is for case only. Headsets are not available on open units.*

Standard Includes	Required to Specify
<ul style="list-style-type: none"> <li>Overhead: Low-Pressure Laminate case with matching or contrasting Low-Pressure Laminate headset</li> <li>Lock plug, polished chrome, on overheads with hinged doors only</li> <li>Lock cylinder included in package, field-installed</li> <li>Wood dowel and glue drawer construction: black</li> <li>Shipped fully assembled</li> </ul>	<ol style="list-style-type: none"> <li>Style number</li> <li>Low-Pressure Laminate color number for overhead and headset</li> <li>Options, if selected (see below)</li> </ol> <p>▶ See <i>Surface Materials</i>, page 506.</p>

Options	U.S. Price	Required to Specify
<b>Attachments</b> <b>Brackets</b> <ul style="list-style-type: none"> <li>Suspended between towers</li> <li>Wall mount brackets                             <ul style="list-style-type: none"> <li>– 36"–66"W</li> <li>– 72"W</li> </ul> </li> </ul>	No cost No cost +\$156 +\$212	Specify with <i>suspended between towers</i> .  Specify with <i>33"–66"W wall mount bracket</i> . Specify with <i>72"W wall mount bracket</i> .
<b>Door Surface</b> <ul style="list-style-type: none"> <li>Laminate</li> <li>Markerboard</li> </ul>	No cost Prices below	Specify laminate color number. Specify with <i>markerboard</i> .
<b>Keys</b> <ul style="list-style-type: none"> <li>Standard key plug</li> <li>Master key plug</li> </ul>	No cost +\$ 39	Specify with <i>standard key plug</i> . Specify with <i>master key plug</i> .

Specification Information						
Style Number	Dimensions D    W    H			Number of Doors	U.S. Base Price	Option (Add \$ to Base Price)  Markerboard

### Overhead with Hinged Doors

AMQCROHHD	16"	36"	15"	2	\$ 810	N.A.
	16"	42"	15"	3	\$ 938	N.A.
	16"	48"	15"	3	\$1073	N.A.
	16"	60"	15"	3	\$1334	N.A.
	16"	66"	15"	4	\$1468	N.A.
	16"	72"	15"	4	\$1543	N.A.

### Overhead with Sliding Doors

AMQCROHSDP	16"	36"	15"	1	\$ 705	+\$124
	16"	42"	15"	1	\$ 833	+\$151
	16"	48"	15"	1	\$ 970	+\$167
	16"	60"	15"	1	\$1228	+\$236
	16"	66"	15"	1	\$1363	+\$281
	16"	72"	15"	1	\$1438	+\$302

### Overhead with No Doors, Open

AMQCROHOP	15"	36"	15"	N.A.	\$ 509	N.A.
	15"	42"	15"	N.A.	\$ 638	N.A.
	15"	48"	15"	N.A.	\$ 772	N.A.
	15"	60"	15"	N.A.	\$1033	N.A.
	15"	66"	15"	N.A.	\$1167	N.A.
	15"	72"	15"	N.A.	\$1240	N.A.

# Stacking Overheads

Tip: Stacking overheads with sliding doors do not lock.

Tip: Handedness is determined while in the seated position.

Tip: If the master key plug is optioned, **AMQLOCK9201XF** must be specified separately to be included.

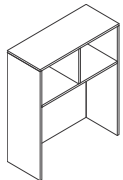
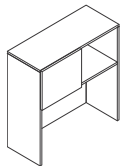
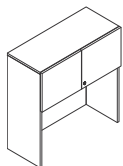
Tip: Overheads with three doors will have two doors hinged right. Overheads with four doors will have two doors hinged left, and two hinged right. Doors will always open from the center out.

Tip: White markerboard (2977) headset finish available with sliding doors only.

Tip: 37.98725"H overheads align with 66½"H storage. 44.17475"H overheads align with 72"H storage.

Tip: Stacking overheads cannot be used with lateral file/lateral file credenza configurations.

Tip: 15"H refers to the height of the storage case.



Standard Includes	Required to Specify
<ul style="list-style-type: none"> <li>Stacking overhead: Low-Pressure Laminate case with matching or contrasting Low-Pressure Laminate headset</li> <li>Lock plug on overheads with hinged doors only</li> <li>Lock cylinder included in package, field-installed</li> <li>Attachment hardware</li> </ul>	<ol style="list-style-type: none"> <li>Style number</li> <li>Low-Pressure Laminate color number for overhead</li> <li>Options, if selected (see below)                     <ul style="list-style-type: none"> <li>▶ See <i>Surface Materials</i>, page 506.</li> </ul> </li> </ol>

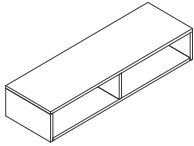
Options	U.S. Price	Required to Specify
<b>Door Surface</b> <ul style="list-style-type: none"> <li>Laminate</li> <li>Markerboard</li> </ul>	No cost Prices below	Specify laminate color number. Specify <i>with markerboard</i> .
<b>Keys</b> <ul style="list-style-type: none"> <li>Standard key plug</li> <li>Master key plug</li> </ul>	No cost +\$39	Specify <i>with standard key plug</i> . Specify <i>with master key plug</i> .

Specification Information						
Style Number	Dimensions D    W    H			Number of Doors	U.S. Base Price	Option (Add \$ to Base Price)
						Markerboard

Overhead with Hinged Doors						
<b>AMQCROHSHD</b>	16"	60"	15"	3	\$1730	N.A.
	16"	66"	15"	4	\$1865	N.A.
	16"	72"	15"	4	\$1996	N.A.

Overhead with Sliding Doors						
<b>AMQCROHSSD</b>	16"	60"	15"	1	\$1624	+\$313
	16"	66"	15"	1	\$1759	+\$360
	16"	72"	15"	1	\$1891	+\$410

Overhead with No Doors, Open						
<b>AMQCROHS</b>	15"	60"	15"	N.A.	\$1211	N.A.
	15"	66"	15"	N.A.	\$1348	N.A.
	15"	72"	15"	N.A.	\$1475	N.A.



Standard Includes	Required to Specify
<ul style="list-style-type: none"> <li>Organizer: Low-Pressure Laminate</li> </ul>	<ol style="list-style-type: none"> <li>Style number</li> <li>Low-Pressure Laminate color number for organizer</li> <li>Options, if selected (see below)</li> </ol> <p>▶ See <i>Surface Materials</i>, page 506.</p>

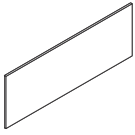
Attachment Brackets	Options	U.S. Price	Required to Specify
	<ul style="list-style-type: none"> <li>Suspended between towers</li> <li>Wall mount brackets                             <ul style="list-style-type: none"> <li>– 36"–66"W</li> <li>– 72"W</li> </ul> </li> </ul>	No cost No cost +\$156 +\$212	Specify <i>with suspended between towers</i> .  Specify <i>with 33"–66"W wall mount bracket</i> . Specify <i>with 72"W wall mount bracket</i> .

Specification Information				
Style Number	Dimensions			U.S. Base Price
	D	W	H	
<b>AMQCRORP</b>	15"	36"	8 <sup>27</sup> / <sub>32</sub> "	\$ 980
	15"	42"	8 <sup>27</sup> / <sub>32</sub> "	\$1071
	15"	48"	8 <sup>27</sup> / <sub>32</sub> "	\$1083
	15"	60"	8 <sup>27</sup> / <sub>32</sub> "	\$1115
	15"	66"	8 <sup>27</sup> / <sub>32</sub> "	\$1167
	15"	72"	8 <sup>27</sup> / <sub>32</sub> "	\$1230



**For Canadian Pricing**  
 Multiply U.S. Price by the Canadian price factor.  
 ▶ See page 1 for details.

# Tackboard



Tip: Remove 1½" in height from the tackboard if paired with a stacking overhead to utilize cable passthrough.

Tip: Tackboard comes with a spacer for a shelf light cord to be routed to the cable passthrough at the bottom of the overhead storage cabinet.

Tip: Tackboards cannot be attached to walls covered by textured paint or wallpaper.

Tip: Width denotes the width of the overhead the tackboard is pairing with. The application option will account for any dimensional changes needed. By selecting stacking, 2¼" will be removed from the overall width of the tackboard. By selecting wall mount, tackboard will ship with the exact specified width.

Standard Includes	Required to Specify
-------------------	---------------------

- Tackboard: fabric
- Attachment hardware

- 1 Style number
  - 2 Fabric color number for tackboard
  - 3 Options, if selected (see below)
- ▶ See *Surface Materials*, page 506.

	Options	U.S. Price	Required to Specify
--	---------	------------	---------------------

<b>Tackboard</b>	<ul style="list-style-type: none"> <li>• Fabric price group 1</li> <li>• Fabric price group 3</li> </ul>	No cost +\$49	Specify fabric color number. Specify fabric color number.
------------------	--	------------------	--

<b>Application</b>	<ul style="list-style-type: none"> <li>• Stacking</li> <li>• Wall mount</li> </ul>	No cost No cost	Specify <i>with stacking application</i> . Specify <i>with wall mount application</i> .
--------------------	--	--------------------	--

<b>Fabric Direction</b>	<ul style="list-style-type: none"> <li>• Horizontal</li> </ul>	No cost	Specify <i>with horizontal fabric direction</i> .
-------------------------	--	---------	---

## Specification Information

Style Number	Dimensions Modular Height	U.S. Base Prices					
		Modular Width					
		36"W	42"W	48"W	60"W	66"W	72"W
<b>AMQCRTB</b>	20¼"	\$446	\$471	\$491	\$560	\$606	\$673
	26¼"	\$489	\$517	\$541	\$614	\$666	\$742



### For Canadian Pricing

Multiply U.S. Price by the Canadian price factor.

▶ See page 1 for details.

*Tip: All round and square table configurations receive a 36" steel X-base with the exception of the 36" diameter round table which receives a 30" steel X-base.*

Standard Includes	Required to Specify
-------------------	---------------------

- |  |   |
|--|---|
| <ul style="list-style-type: none"> <li>• Top: Low-Pressure Laminate with 3mm plastic square edge</li> <li>• X-base column: paint</li> <li>• Ships ready to assemble</li> </ul> | <ol style="list-style-type: none"> <li>1 Style number</li> <li>2 Low-Pressure Laminate color number for table</li> <li>3 Plastic color number for edge</li> <li>4 Paint color number for column</li> <li>5 Options, if selected (see below)</li> </ol> <p>▶ See <i>Surface Materials</i>, page 506.</p> |
|--|---|

Options	U.S. Price	Required to Specify
---------	------------	---------------------

<b>Surface Materials</b> <ul style="list-style-type: none"> <li>• X-base</li> <li>• Black paint</li> <li>• Platinum metallic paint</li> </ul>	No cost +\$25	Specify 7207 Black. Specify 4799 Platinum Metallic.
---	------------------	--

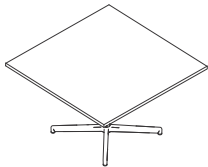
Specification Information			
Style Number	Dimensions Modular		U.S. Base Price
	Width/Dia.	Modular Height	

### Social Table—Round

<b>AMQCRRTBL</b>	36"	28"	\$1093
	48"	28"	\$1379

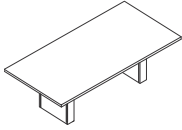
### Social Table—Square

<b>AMQCRSQTBL</b>	36"	28"	\$1093
	48"	28"	\$1379



 **For Canadian Pricing**  
Multiply U.S. Price by the Canadian price factor.  
▶ See page 1 for details.

# Rectangular Conference Table



Tip: Hinged power doors have a 5<sup>5</sup>/<sub>16</sub>"D, 8<sup>5</sup>/<sub>16</sub>"W, and 2"H.

Tip: 72"W and 96"W tables receive two rectangular bases and 120"W and 144"W tables receive three rectangular bases.

Tip: Widths 96"-144" have two-piece tops and will not have matching grain direction.

Tip: One hinged power door comes with 72"W tables, two hinged power doors with 96"W and 120"W tables, and four hinged power doors with 144"W tables.

Standard Includes	Required to Specify
<ul style="list-style-type: none"> <li>• Top: Low-Pressure Laminate with 3 mm plastic square edge</li> <li>• Rectangular table base</li> <li>• Reinforcing channels, if selected</li> <li>• Ships ready to assemble</li> </ul>	<ol style="list-style-type: none"> <li>1 Style number</li> <li>2 Low-Pressure Laminate color number for table</li> <li>3 Options, if selected (see below)</li> </ol> <p>▶ See <i>Surface Materials</i>, page 506.</p>

Options	U.S. Price	Required to Specify
<b>Power</b> <ul style="list-style-type: none"> <li>• No power</li> <li>• Hinged door</li> </ul>	No cost +\$588 per door	Specify <i>with no power</i> . Specify <i>with hinged door</i> .

Specification Information						
Style Number	Dimensions Modular Depth	Base Modular Height	U.S. Base Prices Modular Width			
			72"W	96"W	120"W	144"W
AMQCRRECTBL	36 <sup>1</sup> / <sub>4</sub> "	28"	\$2827	\$3204	\$4296	\$4867
	48"	28"	\$3010	\$3471	\$4625	\$5265



**For Canadian Pricing**  
 Multiply U.S. Price by the Canadian price factor.  
 ▶ See page 1 for details.

## Cafe-Height Table—Round



Standard Includes	Required to Specify
-------------------	---------------------

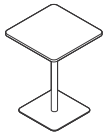
- 1 1/8" thick table top: Low-Pressure Laminate
- Edge band: default color to match laminate
- Column base: paint

- 1 Style number
  - 2 Low-Pressure Laminate color number for table
  - 3 Paint color number for base
- ▶ See *Surface Materials*, page 506.

Specification Information		
Style Number	Diameter	U.S. Price
EMCAFERDTBL	30"	\$1148
	36"	\$1373

Style Number	Diameter	U.S. Price
EMCAFERDTBL	30"	\$1148
	36"	\$1373

## Cafe-Height Table—Square




Standard Includes	Required to Specify
-------------------	---------------------

- 1 1/8" thick table top: Low-Pressure Laminate
- Edge band: default color to match laminate
- Column base: paint

- 1 Style number
  - 2 Low-Pressure Laminate color number for table
  - 3 Paint color number for base
- ▶ See *Surface Materials*, page 506.

Specification Information		
Style Number	Depth	U.S. Price
EMCAFESQTBL	30"	\$1148
	36"	\$1373

Style Number	Depth	U.S. Price
EMCAFESQTBL	30"	\$1148
	36"	\$1373

 **For Canadian Pricing**  
 Multiply U.S. Price by the Canadian price factor.  
 ▶ See page 1 for details.

# Collaborative Table

## Collaborative Table—Round



Tip: Glides on post legs are 1½" long and provide 1" of leveling.

Standard Includes	Required to Specify
<ul style="list-style-type: none"> <li>1½" thick table top: Low-Pressure Laminate</li> <li>Edge band: default color to match laminate</li> <li>Post legs: paint</li> <li>Glides, if post legs are selected</li> </ul>	<ol style="list-style-type: none"> <li>Style number</li> <li>Low-Pressure Laminate color number for table</li> <li>Paint color number for legs</li> <li>Options, if selected (see below)</li> </ol> <p>▶ See <i>Surface Materials</i>, page 506.</p>

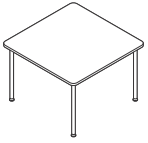
Options	U.S. Price	Required to Specify
<b>Base</b> <ul style="list-style-type: none"> <li>Post legs</li> <li>Column</li> </ul>	No cost Prices below	Specify <i>with post legs</i> . Specify <i>with column</i> .
<b>Casters or Glides</b> <ul style="list-style-type: none"> <li>Glides</li> <li>Two locking and two non locking casters</li> </ul>	No cost +\$73	Specify <i>with glides</i> . Specify <i>with two locking and two non locking casters</i> .

Specification Information			
Style Number	Diameter	U.S. Base Price	Option (Add \$ to Base Price)
<b>EMWRDTBL</b>	30"	\$855	Column +\$210
	36"	\$914	Column +\$445
	48"	\$984	Column +\$603



**For Canadian Pricing**  
Multiply U.S. Price by the Canadian price factor.  
▶ See page 1 for details.

## Collaborative Table—Square



Tip: Glides on post legs are 1½" long and provide 1" of leveling.

Standard Includes	Required to Specify
-------------------	---------------------

- 1½" thick table top: Low-Pressure Laminate
- Edge band: default color to match laminate
- Post legs: paint
- Glides, if post legs are selected

- 1 Style number
  - 2 Low-Pressure Laminate color number for table
  - 3 Paint color number for legs
  - 4 Options, if selected (see below)
- ▶ See *Surface Materials*, page 506.

Options	U.S. Price	Required to Specify
---------	------------	---------------------

<b>Base</b>	<ul style="list-style-type: none"> <li>• Post legs</li> <li>• Column</li> </ul>	No cost Prices below	Specify <i>with post legs</i> . Specify <i>with column</i> .
-------------	---	-------------------------	---

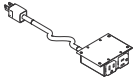
<b>Casters or Glides</b>	<ul style="list-style-type: none"> <li>• Glides</li> <li>• Two locking and two non locking casters</li> </ul>	No cost +\$73	Specify <i>with glides</i> . Specify <i>with two locking and two non locking casters</i> .
--------------------------	---	------------------	---

Specification Information			
Style Number	Diameter	U.S. Base Price	Option (Add \$ to Base Price)

EMWRSQTBL	30"	\$855	• Column +\$210
	36"	\$914	+\$445
	48"	\$984	+\$603

 **For Canadian Pricing**  
 Multiply U.S. Price by the Canadian price factor.  
 ▶ See page 1 for details.

# Single Unit Power Module



Tip: When USB-A+C is specified, there is one USB A+C port.

Standard Includes	Required to Specify
<ul style="list-style-type: none"> <li>• 10' power cord with wall plug</li> <li>• Two simplex receptacles</li> <li>• Two velcro cord management straps</li> <li>• Hardware and plastic cord management clips</li> </ul>	<ul style="list-style-type: none"> <li>1 Style number</li> <li>2 Options, if selected (see below)</li> </ul>

Options	U.S. Price	Required to Specify
<b>Power Configuration</b> <ul style="list-style-type: none"> <li>• Two power</li> <li>• One power + one USB A+C</li> </ul>	<ul style="list-style-type: none"> <li>No cost</li> <li>+\$145</li> </ul>	<ul style="list-style-type: none"> <li>Specify <i>with two power</i>.</li> <li>Specify <i>with one power + one USB A+C</i>.</li> </ul>

Specification Information	
Style Number	U.S. Base Price
EMUWPOWER	\$220



**For Canadian Pricing**  
 Multiply U.S. Price by the Canadian price factor.  
 ▶ See page 1 for details.



Tip: Glides on post legs are 1½" long and provide 1" of leveling.

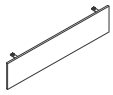
Standard Includes	Required to Specify
<ul style="list-style-type: none"> <li>• Square legs: paint price group 1</li> <li>• Adjusting leveling glides: black plastic</li> <li>• Ships ready to assemble</li> </ul>	<ul style="list-style-type: none"> <li>1 Style number</li> <li>2 Paint color number for legs</li> <li>3 Options, if selected (see below)</li> <li>▶ See <i>Surface Materials</i>, page 506.</li> </ul>

Options	U.S. Price	Required to Specify
<b>Surface Materials</b> <ul style="list-style-type: none"> <li>• Black paint</li> <li>• Platinum metallic paint</li> </ul>	<b>Base</b> <ul style="list-style-type: none"> <li>• Black paint</li> <li>• Platinum metallic paint</li> </ul>	<ul style="list-style-type: none"> <li>No cost</li> <li>+\$37</li> </ul> <ul style="list-style-type: none"> <li>Specify 7207 Black.</li> <li>Specify 4799 Platinum Metallic.</li> </ul>

Specification Information				
Style Number	Dimensions			U.S. Base Price
	D	W	H	
<b>AMQCRSQB</b>	2"	2"	27¼"	\$216

 **For Canadian Pricing**  
 Multiply U.S. Price by the Canadian price factor.  
 ▶ See page 1 for details.

# Modesty Panel



Standard Includes	Required to Specify
-------------------	---------------------

- Modesty panel: Low-Pressure Laminate
- Bracket: merle paint
- Ships ready to assemble

- 1 Style number
- 2 Low-Pressure Laminate color number for modesty panel
- ▶ See *Surface Materials*, page 506.

Specification Information				
• Style Number	• Dimensions • Modular Height	• U.S. Prices		
		• Modular Width		
		• 36"W	• 48"W	• 60"W
<b>AMQCRMP</b>	13¾"	\$446	\$506	\$564



**For Canadian Pricing**  
 Multiply U.S. Price by the Canadian price factor.  
 ▶ See page 1 for details.

## Attachment Kit, Cabinet to Cabinet Application

*Tip: Ganging hardware is used to provide rigidity between cabinets mounted side by side in a panel or wall-mounted application.*

Standard Includes	Required to Specify
<ul style="list-style-type: none"> <li>Attachment kit, four bolts and nuts per kit: bronze only</li> </ul>	Style number

Specification Information		
Style Number	Quantity	U.S. Price
AMQAWAK	1	\$51

## TEKTIS and EMBANK Shared Accessories

*Tip: Reinforcing channels are needed for 54"W of unsupported kneespace.*

*Tip: Support plates are available to connect two worksurfaces and allow one to support the other.*

*Tip: Tie plates are available to provide added strength and alignment between two worksurfaces.*

Standard Includes	Required to Specify
<ul style="list-style-type: none"> <li>Worksurface supports and channels: black paint</li> <li>Attachment hardware</li> </ul>	Style number

Specification Information		
Style Number	Dimension	U.S. Price

### In-Line Support Plates

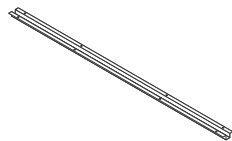
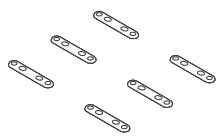
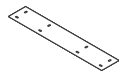
AMQTSATPL	14"D	\$ 92
	20"D	\$ 92

### Package of Six Tie Plates for Side-by-Side Worksurfaces

AMQTSATTIE	7"L	\$129
------------	-----	-------

### Reinforcing Channels

AMQTSATRC	39"W	\$ 64
	48"W	\$ 67
	57"W	\$ 70
	72"W	\$152



 **For Canadian Pricing**  
 Multiply U.S. Price by the Canadian price factor.  
 ▶ See page 1 for details.



---

# Resources

**Lock and Keying**

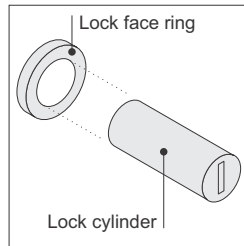
**380**

# Lock and Keying

## For TEKTIS, UPTAKE, and EMBANK Products

**All locking products** are standard with field-installed, keyed-random locks. Locks will ship with lock plug installed. Lock cylinder will be packaged separately and field-installed.

*Tip: If the master key plug is optioned, **AMQLOCK9201XF** must be specified separately to be included.*



**Locks** consist of a field-installed lock cylinder and a field-installed lock face ring.







**Two types of locks** are available—the standard keying system (FR series) and the master keying system (XF series). All the locks in the XF series can be opened with a single master key.

### Field-Installed Keying

**Field-installed locks** are always key random (standard) or master key random (option). Key random means that the locks will be assigned arbitrarily at the factory with key numbers ranging from FR305 to FR999 (Master keying numbers: XF1001 to XF3000). All locks within a unit will be keyed alike.

*Tip: Random keying can mean that different furniture units will have the same key number.*

#### Key Random

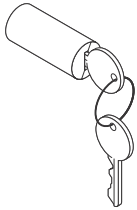
-  FR305
  -  FR421
  -  FR305
  - or
  -  XF1011
  -  XF1042
  -  XF1011
- } XF  
} Master Key

#### Required to Specify

<b>Master key random</b>	No cost	Specify with master key random.
--------------------------	---------	---------------------------------

*Tip: If the master key plug is optioned, **AMQLOCK9201XF** must be specified separately to be included.*

## Lock Cylinders



*Tip: Lock price is included in price of furniture with locks.*

*Tip: For replacement lock cylinders, refer to Service Parts.*

*Tip: If the master key plug is optioned, **AMQLOCK9201XF** must be specified separately to be included.*

Standard Includes	Required to Specify
<ul style="list-style-type: none"> <li>9201 Polished Chrome lock cylinder, standard key random</li> <li>Two keys</li> </ul>	1 Style number 2 Options, if selected (see below)

Options	U.S. Price	Required to Specify
<b>Master key random</b>	No cost	Specify master key random.

### Specification Information


Style Number	U.S. Price
--------------	------------

#### FR Series (Standard Keying System)—Lock Cylinder

<b>AMQLOCK9201FR</b>	No cost
----------------------	---------

#### XF Series (Master Keying System)—Lock Cylinder

<b>AMQLOCK9201XF</b>	No cost
----------------------	---------

 **For Canadian Pricing**  
 Multiply U.S. Price by the Canadian price factor.  
 ▶ See page 1 for details.



---

# Understanding UPTAKE Lockers



**Statement of Line** **384**

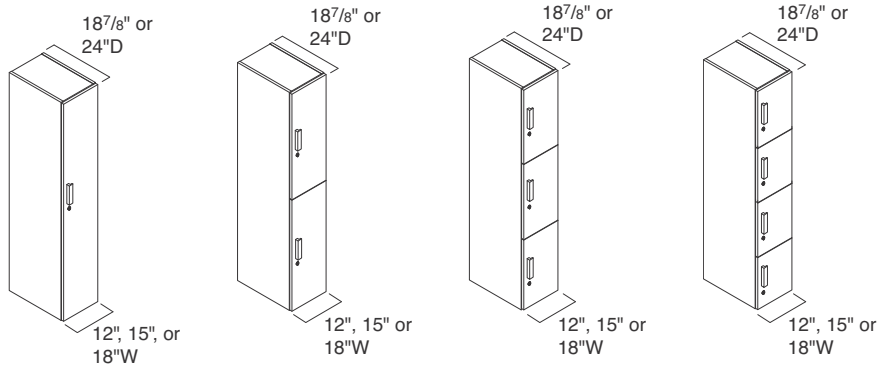


<b>UPTAKE Lockers</b>	<b>386</b>
<b>Interior Configuration Rules</b>	<b>388</b>
<b>Stability Guidelines</b>	<b>391</b>
<b>Electronic Lock Option</b>	<b>392</b>
<b>UPTAKE Digilock Keys</b>	<b>393</b>

# Statement of Line

UPTAKE Lockers

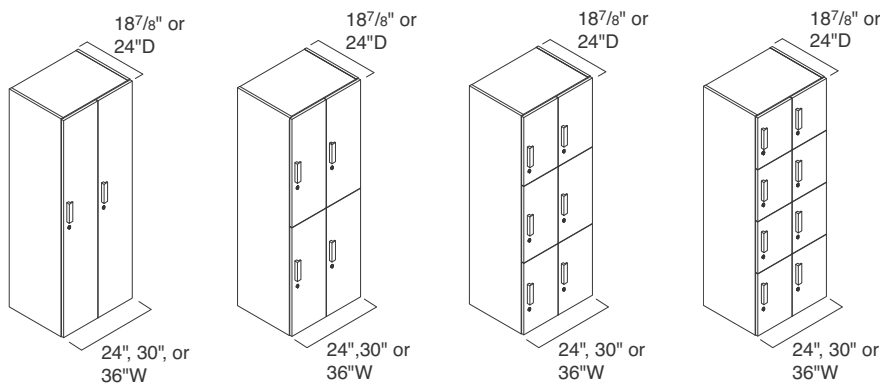
## Single-Wide Lockers



Understanding  
 ▶ Page 386  
 Specifying  
 ▶ Page 396

	1-Door	2-Door	3-Door	4-Door
41.75"H	●	●	N.A.	N.A.
47.9375"H	●	●	●	N.A.
54.125"H	●	●	●	N.A.
66.5"H	●	●	●	●
72"H	●	●	●	●

## Double-Wide Lockers



Understanding  
 ▶ Page 386  
 Specifying  
 ▶ Page 400

	2-Door	4-Door	6-Door	8-Door
41.75"H	●	●	N.A.	N.A.
47.9375"H	●	●	●	N.A.
54.125"H	●	●	●	N.A.
66.5"H	●	●	●	●
72"H	●	●	●	●

## Shelves



Understanding  
 ▶ Page 386  
 Specifying  
 ▶ Page 403

### Adjustable Shelf—Single-Wide Locker

	12"W	15"W	18"W
18.875"D	●	●	●
24"D	●	●	●



Understanding  
 ▶ Page 386  
 Specifying  
 ▶ Page 403

### Adjustable Shelf—Double-Wide Locker

	24"W	30"W	36"W
18.875"D	●	●	●
24"D	●	●	●

*Tip: Width of shelf is sized to fit one shelf into one side of double-wide locker. If a shelf is required for each side of double-wide locker order a quantity of two shelves.*

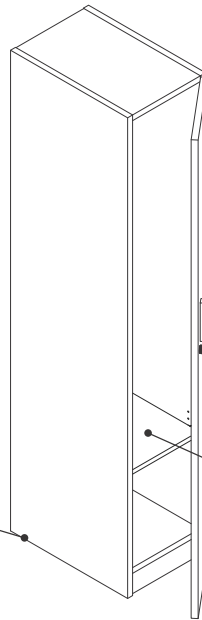
# UPTAKE Lockers

**UPTAKE lockers** provide a space to store a variety of objects including coats, bags, and personal belongings.  
 ▶ Specifying, page 396

**Coat hooks or coat rod** can be specified.

**Leveling glides** adjust to install on uneven floors and have a 1" adjustable range.

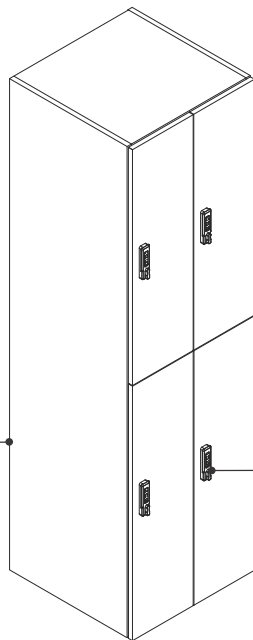
**Finished back** is standard.



**Single-Wide Locker**

**Ledge pulls** come standard when keyed locks are specified.

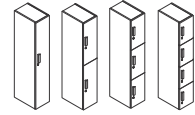
**Adjustable shelf** is available as an option to aid in the division of storage space when needed.



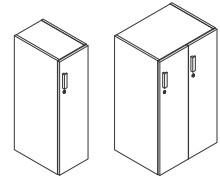
**Double-Wide Locker**

**Digilock VERSA electronic keypad locks** are available as an option.

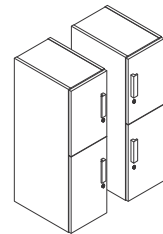
## Product Details



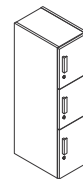
**Four different door configurations** are available.



**Single- or double-wide lockers** are available.



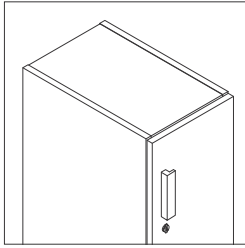
**Door on locker** can be hinged on the left or right. Pull and lock are located on the opposite side of the hinge.



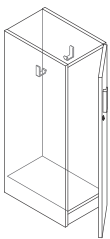
**Headset** available in full front only.

## Actual Dimensions

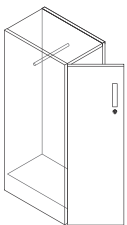
<b>Depth</b>		18 <sup>7</sup> / <sub>8</sub> " or 24"
<b>Width</b>	Single wide	12", 15", or 18"
	Double wide	24", 30", or 36"
<b>Height</b>		41.75", 47.9375", 54.125", 66.5", or 72"



**The inset top construction** provides consistent door gaps and a tighter fit of adjacent units when ganged together.



**A pair of coat hooks** are standard in each opening for 1-door and 2-door units. Coat hooks are available as an option in 3-door and 4-door units.

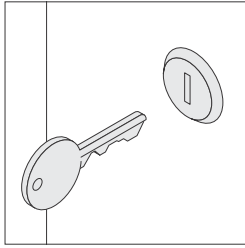


**Coat rod** is available as an option on 1-door and 2-door units that are 24"D only.



Ledge pull

**Ledge pulls on lockers** are defaulted when standard or master key plug is specified. No pull is available when electronic locks are specified.



**If the ledge pull** is specified, locks are available factory-installed and are keyed random only. Master-keyed locks are also available. ▶ *Lock and Keying*, page 380



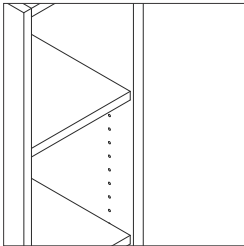
**Digilock Versa**

**Digilock Versa electronic keypad locks, mounted in a vertical orientation**, are available as an option.

**Digilock Versa electronic keypad locks** are powered by two lithium 2450 batteries.

**Programming and manager keys** must be ordered separately.

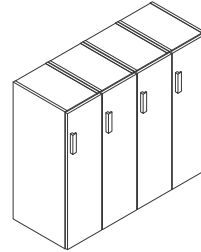
**Application Topics**



**Adjustable shelves** can be added to lockers for additional storage or piling space. Shelves are recessed from the side of the locker. A maximum of two adjustable shelves can be added. See interior configuration rules for restrictions. Mounting holes are located 1¼" apart starting 12" from bottom going to 12" from top. ▶ *See Interior Configuration Rules* for restrictions, page 388.

**Shelf pin holes** are always included even if adjustable shelves are not specified as an option on the locker. This allows for long term flexibility and the addition of adjustable shelves after the initial order (adjustable shelf style numbers **EMLKSHFS** and **EMLKSHFD**).

**1-door lockers 54"H and above** have a fixed shelf located at the top. *Tip: See interior configuration rules for size restrictions for coat hooks, coat rods, and adjustable shelves.* ▶ Page 388.



**Individual single- or double-wide lockers** cannot stand alone. They must be ganged to other lockers or secured to the building structure. Minimum locker numbers depend on depth and width. ▶ *See Stability Guidelines* on page 391.

**Ganging hardware, provided**, joins adjacent storage units side-by-side, back-to-back, or both.

**Storage Capacities and Dimensions**

▶ Page 334

**Surface Materials**

**Case**

- Low-Pressure Laminate

**Headsets**

- Low-Pressure Laminate

**Ledge pull**

- 4799 Platinum Metallic
- 7207 Black

**Keyed lock**

- 9201 Polished Chrome

**Electronic lock**

- 9221 Brushed Nickel

# Interior Configuration Rules

## 1-Door Single Wide and 2-Door Double Wide

	No Coat Hooks and 1 Adjustable Shelf	No Coat Hooks and 2 Adjustable Shelves	Coat Hooks and No Adjustable Shelf	Coat Hooks and 1 Adjustable Shelf	Coat Hooks and 2 Adjustable Shelves	Coat Rod* and No Adjustable Shelf
<b>Height of Unit</b>						
41.75"	●	N.A.	●	●	N.A.	N.A.
47.9375"	●	●	●	●	●	●
54.125"	●	N.A.	●	●	N.A.	N.A.
66.5"	●	●	●	●	●	●
72"	●	●	●	●	●	●

\* Tip: In order to specify coat rod, depth must equal 24"D for all heights.

## 2-Door Single Wide and 4-Door Double Wide

	No Coat Hooks and 1 Adjustable Shelf	No Coat Hooks and 2 Adjustable Shelves	Coat Hooks and No Adjustable Shelf	Coat Hooks and 1 Adjustable Shelf	Coat Hooks and 2 Adjustable Shelves	Coat Rod* and No Adjustable Shelf
<b>Height of Unit</b>						
41.75"	N.A.	N.A.	●	N.A.	N.A.	N.A.
47.9375"	●	N.A.	●	●	N.A.	N.A.
54.125"	●	N.A.	●	●	N.A.	N.A.
66.5"	●	N.A.	●	●	N.A.	N.A.
72"	●	●	●	●	●	N.A.

\* Tip: In order to specify coat rod, depth must equal 24"D for all heights.

## 3-Door Single Wide and 6-Door Double Wide

	No Coat Hooks and 1 Adjustable Shelf	No Coat Hooks and 2 Adjustable Shelves	Coat Hooks and No Adjustable Shelf	Coat Hooks and 1 Adjustable Shelf	Coat Hooks and 2 Adjustable Shelves	Coat Rod* and No Adjustable Shelf
<b>Height of Unit</b>						
47.9375"	N.A.	N.A.	●	N.A.	N.A.	N.A.
54.125"	N.A.	N.A.	●	N.A.	N.A.	N.A.
66.5"	N.A.	N.A.	●	N.A.	N.A.	N.A.
72"	●	N.A.	●	●	N.A.	N.A.

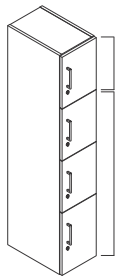
\* Tip: In order to specify coat rod, depth must equal 24"D for all heights.

## 4-Door Single Wide and 8-Door Double Wide

	No Coat Hooks and 1 Adjustable Shelf	No Coat Hooks and 2 Adjustable Shelves	Coat Hooks and No Adjustable Shelf	Coat Hooks and 1 Adjustable Shelf	Coat Hooks and 2 Adjustable Shelves	Coat Rod* and No Adjustable Shelf
<b>Height of Unit</b>						
66.5"	N.A.	N.A.	●	N.A.	N.A.	N.A.
72"	N.A.	N.A.	●	N.A.	N.A.	N.A.

\* Tip: In order to specify coat rod, depth must equal 24"D for all heights.

## Uptake Lockers

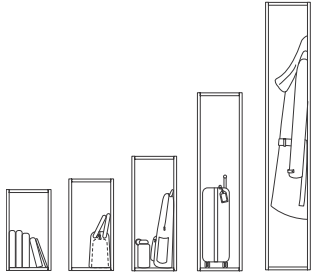


Top Opening

All openings below top opening

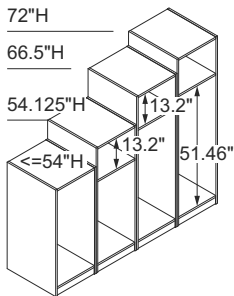
		<b>Height—Full Fronts</b>					
		<b>41.75"</b>	<b>47.9375"</b>	<b>54.125"</b>	<b>66.5"</b>	<b>72"</b>	
<b>1 Door</b>	Opening	36.78"	42.96"	49.15"	61.53"	67.03"	
<b>2 Door</b>	Top Opening	17.84"	20.93"	24.03"	30.22"	32.97"	
<b>2 Door</b>	Bottom Opening	18.13"	21.23"	24.32"	30.51"	33.26"	
<b>3 Door</b>	Top Opening	N.A.	13.58"	15.64"	19.77"	21.60"	
<b>3 Door</b>	Openings below Top Opening	N.A.	13.91"	15.97"	20.10"	21.93"	
<b>4 Door</b>	Top Opening	N.A.	N.A.	N.A.	14.54"	15.92"	
<b>4 Door</b>	Openings below Top Opening	N.A.	N.A.	N.A.	14.87"	16.25"	
		<b>Width</b>					
		<b>12"</b>	<b>15"</b>	<b>18"</b>	<b>24"</b>	<b>30"</b>	<b>36"</b>
	Single Wide	10.39"	13.39"	16.39"	N.A.	N.A.	N.A.
	Double Wide	N.A.	N.A.	N.A.	10.80"	13.80"	16.80"
		<b>Depth</b>					
		<b>18.875"</b>	<b>24"</b>				
		17.10"	22.23"				

**4-Door Single Wide and 8-Door Double Wide, continued**



**Recommended Sizes for Personal Items**

<19.7"	Book, purse, lunch box
19.7"–29.4"	Backpack
29.5"–47.1"	Suitcase
42"+	Coat

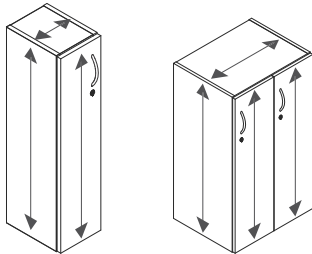


**Available Space Below the Fixed Shelf**

	54.125"H	66.5"H	72"H
Uptake Locker Headset	36.35"	48.72"	51.46"

**Grain Direction**

**Uptake Lockers**



**Single Column**

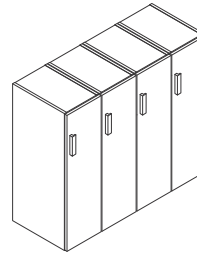
**Double Column**

## Single Run of Lockers

Individual single- or double-wide lockers cannot stand alone. If not secured to the building structure, the minimum locker numbers that need to be ganged depend on depth, height, and width, and are shown in the table below.

If locker widths vary in the application, rules for the narrowest width applies. A double-wide locker counts as two lockers.

Locker Depth (inches)	Locker Height (inches)	Locker Width (inches)	Minimum Locker Number
18 ≤ D ≤ 24	≤ 70	any	3
	> 70	≥ 15	4
		< 15	6

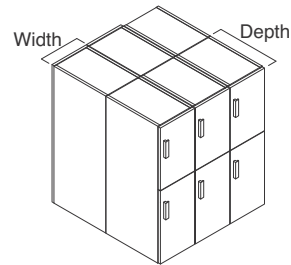


## Back-to-Back Lockers

Individual lockers cannot stand alone. If not secured to the building structure, the minimum locker numbers that need to be ganged depend on width and are shown in the table below.

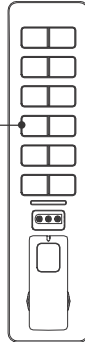
If locker depths are different on both sides, then the rules for the shallower depth applies. A double-wide locker counts as two lockers. These guidelines apply to all locker heights (41.75"–72").

Depth	Locker Width	Minimum Locker Number side-to-side
Any	≥ 12"	2
	> 12"	3

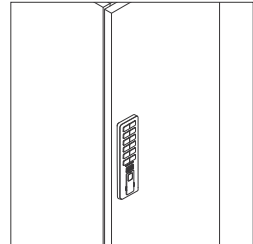


# Electronic Lock Option

**Keypad** has visual and audible indicators.



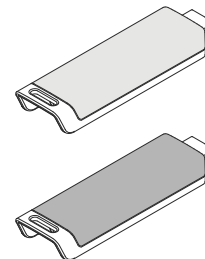
## Product Details



**Digilock Versa electronic keypad locks** are surface mounted on the door.

**Digilock Versa electronic keypad locks** come set to a shared use mode. The user locks with their credential and unlocks with the same credential. Once unlocked, the lock is reset for another user.

**Digilock Versa electronic keypad locks** are powered by two lithium 2450 batteries.



**The programming key and manager key,** ordered separately, are required if the electronic lock option is selected.

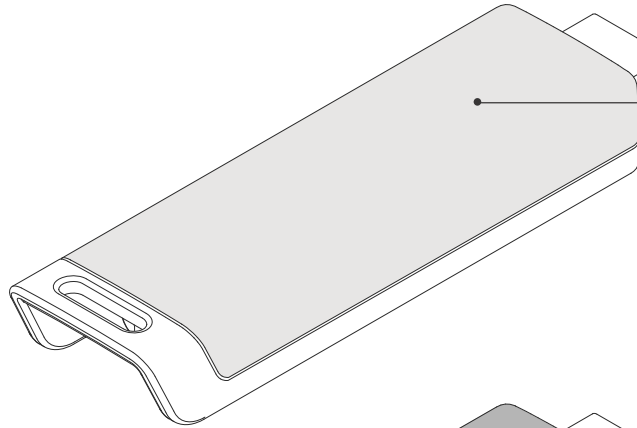
► Specifying, page 404

## Surface Materials

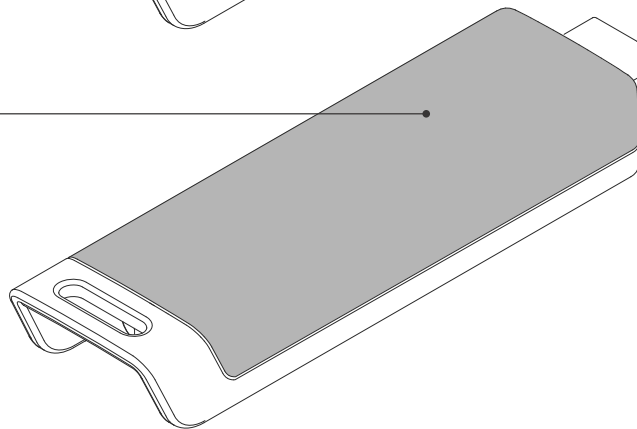
**Lock body**

- 9211 Nickel

- **Digilock Versa electronic keypad locks** enable facility managers to modify lock programming with a unique programming key and override locks using manager keys.
- Programming and manager keys are required if keyless lock option is selected.
- ▶ Specifying, page 432

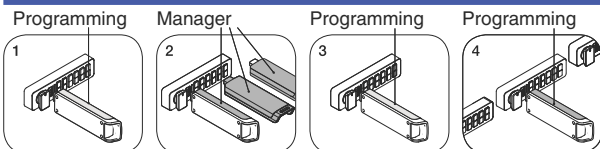


**The programming key** is used during installation to pair the manager key to the lock.



**The manager key** is used to override the lock when a credential is lost or forgotten or the battery loses power. Additional manager keys can be paired at any time. One manager keys may be paired to infinite locks; however, each lock may only pair with up to six manager keys.

## How to Program



1. Insert the programming key. A two-toned beep will be heard and the LED light will start to flash.
  2. While the LED light is flashing, insert one manager key at a time. A beep will be heard for each manager key that is programmed.
  3. Insert the programming key. A two-toned beep will be heard and the LED light will stop flashing.
  4. Repeat previous steps for each lock.
- Tip: The locks will arrive in the factory setting. During the process of pairing the manager key(s), the locks will be programmed into the shared setting.*



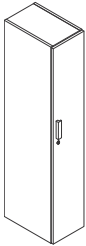
---

# Specifying UPTAKE Lockers

---

<b>UPTAKE Lockers</b>	<b>396</b>
<b>UPTAKE Adjustable Shelf</b>	<b>403</b>
<b>UPTAKE Digilock Keys</b>	<b>404</b>

# Uptake Lockers



Tip: Lockers have an inset top construction which provides consistent door gaps and a tighter fit of adjacent units when ganged together.

Tip: Heights do not apply to all configurations.

Tip: Pricing is per shelf. Adjustable shelf option applies per opening.

Tip: If Digilock Versa is selected, the Digilock programming key and manager key must be specified separately for proper setup. Additional keys are available.

Tip: Shelf option is per opening. For example, if one adjustable shelf is optioned on a 3-door unit, three adjustable shelves will be included.

Tip: Coat rod available on 24"D lockers only regardless of height and without adjustable shelf.

## Standard Includes

- Locker: Low-Pressure Laminate
- Headset: Low-Pressure Laminate
- Ledge pull, if keyed lock selected: 9201 Polished Chrome
- Lock face ring with plastic plug to accommodate lock cylinder, if keyed lock selected: 9201 Polished Chrome
- Fixed shelf on one-door units 54"H and taller
- Two coat hooks on 18"D locker, if selected
- One coat rod on 24"D locker, if selected
- 1/4" adjustable leveling glides
- Ganging hardware

## Required to Specify

- 1 Style number
- 2 Low-Pressure Laminate color number for case and headset
- 3 Options, if selected (see below)
  - ▶ See *Surface Materials*, page 506.

	Options	U.S. Price	Required to Specify
<b>Door</b>	<ul style="list-style-type: none"> <li>• Door hinged left</li> <li>• Door hinged right</li> </ul>	No cost No cost	Specify with door hinged left. Specify with door hinged right.
<b>Lock</b>	<ul style="list-style-type: none"> <li>• Standard key plug</li> <li>• Master key plug</li> <li>• Digilock Versa Keypad</li> </ul>	No cost +\$ 39 +\$249	Specify with standard key plug. Specify with master key plug. Specify with digilock versa keypad.
<b>Adjustable Shelf</b>	<ul style="list-style-type: none"> <li>• No adjustable shelf</li> <li>• One adjustable shelf</li> <li>• Two adjustable shelves</li> </ul>	No cost Prices below Prices below	Specify with no adjustable shelf. Specify with one adjustable shelf. Specify with two adjustable shelves.
<b>Interior Configuration</b>	<ul style="list-style-type: none"> <li>• Coat hooks</li> <li>• No hooks</li> <li>• Coat rod</li> </ul>	No cost No cost +\$ 24	Specify with coat hooks. Specify with no hooks. Specify with coat rod.

Dimensions		Add to U.S. Base Price
D	W	

## Adjustable Shelf for Use with Single-Wide Lockers

18 <sup>7</sup> / <sub>8</sub> "	12"	+\$73
24"	12"	+\$78
18 <sup>7</sup> / <sub>8</sub> "	15"	+\$83
24"	15"	+\$89
18 <sup>7</sup> / <sub>8</sub> "	18"	+\$94
24"	18"	+\$99
:	:	:

## Adjustable Shelf for Use with Double-Wide Lockers

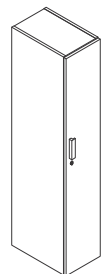
18 <sup>7</sup> / <sub>8</sub> "	24"	+\$73
24"	24"	+\$78
18 <sup>7</sup> / <sub>8</sub> "	30"	+\$83
24"	30"	+\$89
18 <sup>7</sup> / <sub>8</sub> "	36"	+\$94
24"	36"	+\$99
:	:	:



### For Canadian Pricing

Multiply U.S. Price by the Canadian price factor.

▶ See page 1 for details.



**Specification Information**

Style Number	Dimensions			U.S. Base Price
	W	D	H	

**Single-Wide Lockers—One Door**

Style Number	W	D	H	U.S. Base Price
EMLKS1	12"	18 <sup>7</sup> / <sub>8</sub> "	41 <sup>3</sup> / <sub>4</sub> "	\$1368
	12"	18 <sup>7</sup> / <sub>8</sub> "	47 <sup>15</sup> / <sub>16</sub> "	\$1406
	12"	18 <sup>7</sup> / <sub>8</sub> "	54 <sup>1</sup> / <sub>8</sub> "	\$1443
	12"	18 <sup>7</sup> / <sub>8</sub> "	66 <sup>1</sup> / <sub>2</sub> "	\$1481
	12"	18 <sup>7</sup> / <sub>8</sub> "	72"	\$1518
	12"	24"	41 <sup>3</sup> / <sub>4</sub> "	\$1406
	12"	24"	47 <sup>15</sup> / <sub>16</sub> "	\$1443
	12"	24"	54 <sup>1</sup> / <sub>8</sub> "	\$1481
	12"	24"	66 <sup>1</sup> / <sub>2</sub> "	\$1518
	12"	24"	72"	\$1556
	15"	18 <sup>7</sup> / <sub>8</sub> "	41 <sup>3</sup> / <sub>4</sub> "	\$1406
	15"	18 <sup>7</sup> / <sub>8</sub> "	47 <sup>15</sup> / <sub>16</sub> "	\$1443
	15"	18 <sup>7</sup> / <sub>8</sub> "	54 <sup>1</sup> / <sub>8</sub> "	\$1481
	15"	18 <sup>7</sup> / <sub>8</sub> "	66 <sup>1</sup> / <sub>2</sub> "	\$1518
	15"	18 <sup>7</sup> / <sub>8</sub> "	72"	\$1556
	15"	24"	41 <sup>3</sup> / <sub>4</sub> "	\$1443
	15"	24"	47 <sup>15</sup> / <sub>16</sub> "	\$1481
	15"	24"	54 <sup>1</sup> / <sub>8</sub> "	\$1518
	15"	24"	66 <sup>1</sup> / <sub>2</sub> "	\$1556
	15"	24"	72"	\$1594
	18"	18 <sup>7</sup> / <sub>8</sub> "	41 <sup>3</sup> / <sub>4</sub> "	\$1443
	18"	18 <sup>7</sup> / <sub>8</sub> "	47 <sup>15</sup> / <sub>16</sub> "	\$1481
	18"	18 <sup>7</sup> / <sub>8</sub> "	54 <sup>1</sup> / <sub>8</sub> "	\$1518
	18"	18 <sup>7</sup> / <sub>8</sub> "	66 <sup>1</sup> / <sub>2</sub> "	\$1556
	18"	18 <sup>7</sup> / <sub>8</sub> "	72"	\$1594
	18"	24"	41 <sup>3</sup> / <sub>4</sub> "	\$1481
	18"	24"	47 <sup>15</sup> / <sub>16</sub> "	\$1518
	18"	24"	54 <sup>1</sup> / <sub>8</sub> "	\$1556
	18"	24"	66 <sup>1</sup> / <sub>2</sub> "	\$1594
	18"	24"	72"	\$1632

► Specification Information, continued on next page

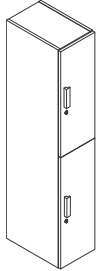
 **For Canadian Pricing**  
 Multiply U.S. Price by the Canadian price factor.  
 ► See page 1 for details.

► Specification Information, continued from previous page

**Specification Information**

Style Number	Dimensions			U.S. Base Price
	W	D	H	

**Single-Wide Lockers—Two Door**



<b>EMLKS2</b>	12"	18 <sup>7</sup> / <sub>8</sub> "	41 <sup>3</sup> / <sub>4</sub> "	\$1471
	12"	18 <sup>7</sup> / <sub>8</sub> "	47 <sup>15</sup> / <sub>16</sub> "	\$1509
	12"	18 <sup>7</sup> / <sub>8</sub> "	54 <sup>1</sup> / <sub>8</sub> "	\$1547
	12"	18 <sup>7</sup> / <sub>8</sub> "	66 <sup>1</sup> / <sub>2</sub> "	\$1585
	12"	18 <sup>7</sup> / <sub>8</sub> "	72"	\$1623
	12"	24"	41 <sup>3</sup> / <sub>4</sub> "	\$1509
	12"	24"	47 <sup>15</sup> / <sub>16</sub> "	\$1547
	12"	24"	54 <sup>1</sup> / <sub>8</sub> "	\$1585
	12"	24"	66 <sup>1</sup> / <sub>2</sub> "	\$1623
	12"	24"	72"	\$1660
	15"	18 <sup>7</sup> / <sub>8</sub> "	41 <sup>3</sup> / <sub>4</sub> "	\$1509
	15"	18 <sup>7</sup> / <sub>8</sub> "	47 <sup>15</sup> / <sub>16</sub> "	\$1547
	15"	18 <sup>7</sup> / <sub>8</sub> "	54 <sup>1</sup> / <sub>8</sub> "	\$1585
	15"	18 <sup>7</sup> / <sub>8</sub> "	66 <sup>1</sup> / <sub>2</sub> "	\$1623
	15"	18 <sup>7</sup> / <sub>8</sub> "	72"	\$1660
	15"	24"	41 <sup>3</sup> / <sub>4</sub> "	\$1547
	15"	24"	47 <sup>15</sup> / <sub>16</sub> "	\$1585
	15"	24"	54 <sup>1</sup> / <sub>8</sub> "	\$1623
	15"	24"	66 <sup>1</sup> / <sub>2</sub> "	\$1660
	15"	24"	72"	\$1697
	18"	18 <sup>7</sup> / <sub>8</sub> "	41 <sup>3</sup> / <sub>4</sub> "	\$1547
	18"	18 <sup>7</sup> / <sub>8</sub> "	47 <sup>15</sup> / <sub>16</sub> "	\$1585
	18"	18 <sup>7</sup> / <sub>8</sub> "	54 <sup>1</sup> / <sub>8</sub> "	\$1623
	18"	18 <sup>7</sup> / <sub>8</sub> "	66 <sup>1</sup> / <sub>2</sub> "	\$1660
	18"	18 <sup>7</sup> / <sub>8</sub> "	72"	\$1697
	18"	24"	41 <sup>3</sup> / <sub>4</sub> "	\$1585
	18"	24"	47 <sup>15</sup> / <sub>16</sub> "	\$1623
	18"	24"	54 <sup>1</sup> / <sub>8</sub> "	\$1660
	18"	24"	66 <sup>1</sup> / <sub>2</sub> "	\$1697
	18"	24"	72"	\$1735

► Specification Information, continued on next page



**For Canadian Pricing**

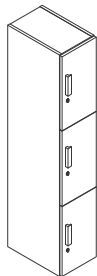
Multiply U.S. Price by the Canadian price factor.

► See page 1 for details.

► Specification Information, continued from previous page

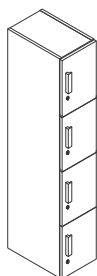
**Specification Information**

Style Number	Dimensions			U.S. Base Price
	W	D	H	



**Single-Wide Lockers—Three Door**

<b>EMLKS3</b>	12"	18 <sup>7</sup> / <sub>8</sub> "	47 <sup>15</sup> / <sub>16</sub> "	\$1613
	12"	18 <sup>7</sup> / <sub>8</sub> "	54 <sup>1</sup> / <sub>8</sub> "	\$1651
	12"	18 <sup>7</sup> / <sub>8</sub> "	66 <sup>1</sup> / <sub>2</sub> "	\$1689
	12"	18 <sup>7</sup> / <sub>8</sub> "	72"	\$1726
	12"	24"	47 <sup>15</sup> / <sub>16</sub> "	\$1651
	12"	24"	54 <sup>1</sup> / <sub>8</sub> "	\$1689
	12"	24"	66 <sup>1</sup> / <sub>2</sub> "	\$1726
	12"	24"	72"	\$1764
	15"	18 <sup>7</sup> / <sub>8</sub> "	47 <sup>15</sup> / <sub>16</sub> "	\$1651
	15"	18 <sup>7</sup> / <sub>8</sub> "	54 <sup>1</sup> / <sub>8</sub> "	\$1689
	15"	18 <sup>7</sup> / <sub>8</sub> "	66 <sup>1</sup> / <sub>2</sub> "	\$1726
	15"	18 <sup>7</sup> / <sub>8</sub> "	72"	\$1764
	15"	24"	47 <sup>15</sup> / <sub>16</sub> "	\$1689
	15"	24"	54 <sup>1</sup> / <sub>8</sub> "	\$1726
	15"	24"	66 <sup>1</sup> / <sub>2</sub> "	\$1764
	15"	24"	72"	\$1802
	18"	18 <sup>7</sup> / <sub>8</sub> "	47 <sup>15</sup> / <sub>16</sub> "	\$1689
	18"	18 <sup>7</sup> / <sub>8</sub> "	54 <sup>1</sup> / <sub>8</sub> "	\$1726
	18"	18 <sup>7</sup> / <sub>8</sub> "	66 <sup>1</sup> / <sub>2</sub> "	\$1764
	18"	18 <sup>7</sup> / <sub>8</sub> "	72"	\$1802
	18"	24"	47 <sup>15</sup> / <sub>16</sub> "	\$1726
	18"	24"	54 <sup>1</sup> / <sub>8</sub> "	\$1764
	18"	24"	66 <sup>1</sup> / <sub>2</sub> "	\$1802
	18"	24"	72"	\$1840



**Single-Wide Lockers—Four Door**

<b>EMLKS4</b>	12"	18 <sup>7</sup> / <sub>8</sub> "	66 <sup>1</sup> / <sub>2</sub> "	\$1791
	12"	18 <sup>7</sup> / <sub>8</sub> "	72"	\$1829
	12"	24"	66 <sup>1</sup> / <sub>2</sub> "	\$1829
	12"	24"	72"	\$1867
	15"	18 <sup>7</sup> / <sub>8</sub> "	66 <sup>1</sup> / <sub>2</sub> "	\$1829
	15"	18 <sup>7</sup> / <sub>8</sub> "	72"	\$1867
	15"	24"	66 <sup>1</sup> / <sub>2</sub> "	\$1867
	15"	24"	72"	\$1905
	18"	18 <sup>7</sup> / <sub>8</sub> "	66 <sup>1</sup> / <sub>2</sub> "	\$1867
	18"	18 <sup>7</sup> / <sub>8</sub> "	72"	\$1905
	18"	24"	66 <sup>1</sup> / <sub>2</sub> "	\$1905
	18"	24"	72"	\$1943

 **For Canadian Pricing**  
 Multiply U.S. Price by the Canadian price factor.  
 ► See page 1 for details.

► Specification Information, continued on next page

► Specification Information, continued from previous page

**Specification Information**

Style Number	Dimensions			U.S. Base Price
	W	D	H	

**Double-Wide Lockers—Two Door**



<b>EMLKD2</b>	24"	18 <sup>7</sup> / <sub>8</sub> "	41 <sup>3</sup> / <sub>4</sub> "	\$2461
	24"	18 <sup>7</sup> / <sub>8</sub> "	47 <sup>15</sup> / <sub>16</sub> "	\$2529
	24"	18 <sup>7</sup> / <sub>8</sub> "	54 <sup>1</sup> / <sub>8</sub> "	\$2596
	24"	18 <sup>7</sup> / <sub>8</sub> "	66 <sup>1</sup> / <sub>2</sub> "	\$2666
	24"	18 <sup>7</sup> / <sub>8</sub> "	72"	\$2734
	24"	24"	41 <sup>3</sup> / <sub>4</sub> "	\$2529
	24"	24"	47 <sup>15</sup> / <sub>16</sub> "	\$2596
	24"	24"	54 <sup>1</sup> / <sub>8</sub> "	\$2666
	24"	24"	66 <sup>1</sup> / <sub>2</sub> "	\$2734
	24"	24"	72"	\$2801
	30"	18 <sup>7</sup> / <sub>8</sub> "	41 <sup>3</sup> / <sub>4</sub> "	\$2529
	30"	18 <sup>7</sup> / <sub>8</sub> "	47 <sup>15</sup> / <sub>16</sub> "	\$2596
	30"	18 <sup>7</sup> / <sub>8</sub> "	54 <sup>1</sup> / <sub>8</sub> "	\$2666
	30"	18 <sup>7</sup> / <sub>8</sub> "	66 <sup>1</sup> / <sub>2</sub> "	\$2734
	30"	18 <sup>7</sup> / <sub>8</sub> "	72"	\$2801
	30"	24"	41 <sup>3</sup> / <sub>4</sub> "	\$2596
	30"	24"	47 <sup>15</sup> / <sub>16</sub> "	\$2666
	30"	24"	54 <sup>1</sup> / <sub>8</sub> "	\$2734
	30"	24"	66 <sup>1</sup> / <sub>2</sub> "	\$2801
	30"	24"	72"	\$2869
	36"	18 <sup>7</sup> / <sub>8</sub> "	41 <sup>3</sup> / <sub>4</sub> "	\$2596
	36"	18 <sup>7</sup> / <sub>8</sub> "	47 <sup>15</sup> / <sub>16</sub> "	\$2666
	36"	18 <sup>7</sup> / <sub>8</sub> "	54 <sup>1</sup> / <sub>8</sub> "	\$2734
	36"	18 <sup>7</sup> / <sub>8</sub> "	66 <sup>1</sup> / <sub>2</sub> "	\$2801
	36"	18 <sup>7</sup> / <sub>8</sub> "	72"	\$2869
	36"	24"	41 <sup>3</sup> / <sub>4</sub> "	\$2666
	36"	24"	47 <sup>15</sup> / <sub>16</sub> "	\$2734
	36"	24"	54 <sup>1</sup> / <sub>8</sub> "	\$2801
	36"	24"	66 <sup>1</sup> / <sub>2</sub> "	\$2869
	36"	24"	72"	\$2937

► Specification Information, continued on next page



**For Canadian Pricing**

Multiply U.S. Price by the Canadian price factor.

► See page 1 for details.

► Specification Information, continued from previous page

**Specification Information**

Style Number	Dimensions			U.S. Base Price
	W	D	H	

**Double-Wide Lockers—Four Door**



<b>EMLKD4</b>	24"	18 <sup>7</sup> / <sub>8</sub> "	41 <sup>3</sup> / <sub>4</sub> "	\$2648
	24"	18 <sup>7</sup> / <sub>8</sub> "	47 <sup>15</sup> / <sub>16</sub> "	\$2716
	24"	18 <sup>7</sup> / <sub>8</sub> "	54 <sup>1</sup> / <sub>8</sub> "	\$2784
	24"	18 <sup>7</sup> / <sub>8</sub> "	66 <sup>1</sup> / <sub>2</sub> "	\$2853
	24"	18 <sup>7</sup> / <sub>8</sub> "	72"	\$2920
	24"	24"	41 <sup>3</sup> / <sub>4</sub> "	\$2716
	24"	24"	47 <sup>15</sup> / <sub>16</sub> "	\$2784
	24"	24"	54 <sup>1</sup> / <sub>8</sub> "	\$2853
	24"	24"	66 <sup>1</sup> / <sub>2</sub> "	\$2920
	24"	24"	72"	\$2988
	30"	18 <sup>7</sup> / <sub>8</sub> "	41 <sup>3</sup> / <sub>4</sub> "	\$2716
	30"	18 <sup>7</sup> / <sub>8</sub> "	47 <sup>15</sup> / <sub>16</sub> "	\$2784
	30"	18 <sup>7</sup> / <sub>8</sub> "	54 <sup>1</sup> / <sub>8</sub> "	\$2853
	30"	18 <sup>7</sup> / <sub>8</sub> "	66 <sup>1</sup> / <sub>2</sub> "	\$2920
	30"	18 <sup>7</sup> / <sub>8</sub> "	72"	\$2988
	30"	24"	41 <sup>3</sup> / <sub>4</sub> "	\$2784
	30"	24"	47 <sup>15</sup> / <sub>16</sub> "	\$2853
	30"	24"	54 <sup>1</sup> / <sub>8</sub> "	\$2920
	30"	24"	66 <sup>1</sup> / <sub>2</sub> "	\$2988
	30"	24"	72"	\$3055
	36"	18 <sup>7</sup> / <sub>8</sub> "	41 <sup>3</sup> / <sub>4</sub> "	\$2784
	36"	18 <sup>7</sup> / <sub>8</sub> "	47 <sup>15</sup> / <sub>16</sub> "	\$2853
	36"	18 <sup>7</sup> / <sub>8</sub> "	54 <sup>1</sup> / <sub>8</sub> "	\$2920
	36"	18 <sup>7</sup> / <sub>8</sub> "	66 <sup>1</sup> / <sub>2</sub> "	\$2988
	36"	18 <sup>7</sup> / <sub>8</sub> "	72"	\$3055
	36"	24"	41 <sup>3</sup> / <sub>4</sub> "	\$2853
	36"	24"	47 <sup>15</sup> / <sub>16</sub> "	\$2920
	36"	24"	54 <sup>1</sup> / <sub>8</sub> "	\$2988
	36"	24"	66 <sup>1</sup> / <sub>2</sub> "	\$3055
	36"	24"	72"	\$3124

► Specification Information, continued on next page

 **For Canadian Pricing**  
 Multiply U.S. Price by the Canadian price factor.  
 ► See page 1 for details.

► Specification Information, continued from previous page

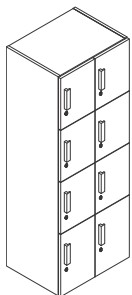
**Specification Information**

Style Number	Dimensions			U.S. Base Price
	W	D	H	



**Double-Wide Lockers—Six Door**

Style Number	W	D	H	U.S. Base Price
<b>EMLKD6</b>	24"	18 <sup>7</sup> / <sub>8</sub> "	47 <sup>15</sup> / <sub>16</sub> "	\$2903
	24"	18 <sup>7</sup> / <sub>8</sub> "	54 <sup>1</sup> / <sub>8</sub> "	\$2971
	24"	18 <sup>7</sup> / <sub>8</sub> "	66 <sup>1</sup> / <sub>2</sub> "	\$3038
	24"	18 <sup>7</sup> / <sub>8</sub> "	72"	\$3107
	24"	24"	47 <sup>15</sup> / <sub>16</sub> "	\$2971
	24"	24"	54 <sup>1</sup> / <sub>8</sub> "	\$3038
	24"	24"	66 <sup>1</sup> / <sub>2</sub> "	\$3107
	24"	24"	72"	\$3174
	30"	18 <sup>7</sup> / <sub>8</sub> "	47 <sup>15</sup> / <sub>16</sub> "	\$2971
	30"	18 <sup>7</sup> / <sub>8</sub> "	54 <sup>1</sup> / <sub>8</sub> "	\$3038
	30"	18 <sup>7</sup> / <sub>8</sub> "	66 <sup>1</sup> / <sub>2</sub> "	\$3107
	30"	18 <sup>7</sup> / <sub>8</sub> "	72"	\$3174
	30"	24"	47 <sup>15</sup> / <sub>16</sub> "	\$3038
	30"	24"	54 <sup>1</sup> / <sub>8</sub> "	\$3107
	30"	24"	66 <sup>1</sup> / <sub>2</sub> "	\$3174
	30"	24"	72"	\$3243
	36"	18 <sup>7</sup> / <sub>8</sub> "	47 <sup>15</sup> / <sub>16</sub> "	\$3038
	36"	18 <sup>7</sup> / <sub>8</sub> "	54 <sup>1</sup> / <sub>8</sub> "	\$3107
	36"	18 <sup>7</sup> / <sub>8</sub> "	66 <sup>1</sup> / <sub>2</sub> "	\$3174
	36"	18 <sup>7</sup> / <sub>8</sub> "	72"	\$3243
	36"	24"	47 <sup>15</sup> / <sub>16</sub> "	\$3107
	36"	24"	54 <sup>1</sup> / <sub>8</sub> "	\$3174
	36"	24"	66 <sup>1</sup> / <sub>2</sub> "	\$3243
	36"	24"	72"	\$3312



**Double-Wide Lockers—Eight Door**

Style Number	W	D	H	U.S. Base Price
<b>EMLKD8</b>	24"	18 <sup>7</sup> / <sub>8</sub> "	66 <sup>1</sup> / <sub>2</sub> "	\$3225
	24"	18 <sup>7</sup> / <sub>8</sub> "	72"	\$3294
	24"	24"	66 <sup>1</sup> / <sub>2</sub> "	\$3294
	24"	24"	72"	\$3362
	30"	18 <sup>7</sup> / <sub>8</sub> "	66 <sup>1</sup> / <sub>2</sub> "	\$3294
	30"	18 <sup>7</sup> / <sub>8</sub> "	72"	\$3362
	30"	24"	66 <sup>1</sup> / <sub>2</sub> "	\$3362
	30"	24"	72"	\$3429
	36"	18 <sup>7</sup> / <sub>8</sub> "	66 <sup>1</sup> / <sub>2</sub> "	\$3362
	36"	18 <sup>7</sup> / <sub>8</sub> "	72"	\$3429
	36"	24"	66 <sup>1</sup> / <sub>2</sub> "	\$3429
	36"	24"	72"	\$3497



**For Canadian Pricing**

Multiply U.S. Price by the Canadian price factor.

► See page 1 for details.

Tip: Widths do not apply to all configurations.

Tip: Adjustable shelf for double-wide locker includes one shelf for use in one side of the double-wide locker.

Tip: Width listed for double-wide locker is locker width, shelf width will be sized to fit in one side of double-wide locker.

Tip: **EMLKSHFS** and **EMLKSHFD** should only be specified as separate line items if extra adjustable shelves are needed beyond what can be optioned on. Otherwise, specify adjustable shelves as options within the locker style numbers.



Standard Includes	Required to Specify
<ul style="list-style-type: none"> <li>Shelf: Low-Pressure Laminate case</li> <li>Mounting hardware</li> </ul>	<ul style="list-style-type: none"> <li>1 Style number</li> <li>2 Low-Pressure Laminate color number for shelf</li> <li>▶ See <i>Surface Materials</i>, page 506.</li> </ul>

### Specification Information

Style Number	Dimensions		U.S. Price
	W	D	

#### Adjustable Shelf—Single-Wide Locker

<b>EMLKSHFS</b>	12"	18 <sup>7</sup> / <sub>8</sub> "	\$73
	12"	24"	\$78
	15"	18 <sup>7</sup> / <sub>8</sub> "	\$83
	15"	24"	\$89
	18"	18 <sup>7</sup> / <sub>8</sub> "	\$94
	18"	24"	\$99

#### Adjustable Shelf—Double-Wide Locker

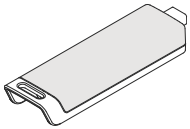
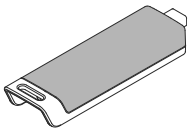
<b>EMLKSHFD</b>	12"	18 <sup>7</sup> / <sub>8</sub> "	\$73
	12"	24"	\$78
	15"	18 <sup>7</sup> / <sub>8</sub> "	\$83
	15"	24"	\$89
	18"	18 <sup>7</sup> / <sub>8</sub> "	\$94
	18"	24"	\$99

**For Canadian Pricing**  
 Multiply U.S. Price by the Canadian price factor.  
 ▶ See page 1 for details.

# Keys

*Tip: The manager key is available as an accommodation to the locking unit.*

*Tip: The manager and programming keys must be specified if the Digilock versa keypad option is optioned.*



Standard Includes	Required to Specify
-------------------	---------------------

- Digilock key: 9211 Nickel
- Instructions

Style number

Specification Information	
---------------------------	--

• **Style Number**

• **U.S. Price**

## Manager Key

<b>EMLKMKEY</b>	\$106
-----------------	-------

## Programming Key

<b>EMLKPKEY</b>	\$134
-----------------	-------





### For Canadian Pricing

Multiply U.S. Price by the Canadian price factor.

▶ See page 1 for details.

---

# West Elm Furniture

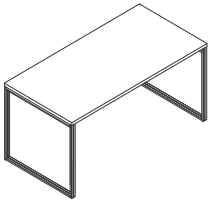
	
<b>Statement of Line</b>	<b>406</b>
	
<b>Greenpoint</b>	
Understanding	<b>408</b>
Specifying	<b>410</b>
<b>Linear Personal Table</b>	
Specifying	<b>413</b>

# Statement of Line

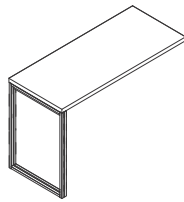
## Furniture

### Greenpoint Private Office

#### Desks and Returns

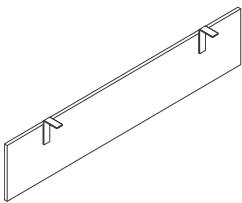


**Private Desk**  
Understanding  
▶ Page 408  
Specifying  
▶ Page 410



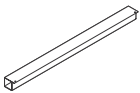
**Desk Return with Leg**  
Understanding  
▶ Page 408  
Specifying  
▶ Page 411

#### Modesty Panel



Understanding  
▶ Page 408  
Specifying  
▶ Page 411

#### Wire Managers

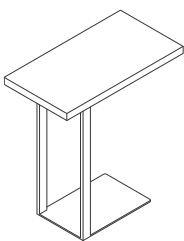


**1 3/4" D Wire Manager**  
Specifying  
▶ Page 412



**Wire Clip**  
Specifying  
▶ Page 412

#### Linear Personal Table

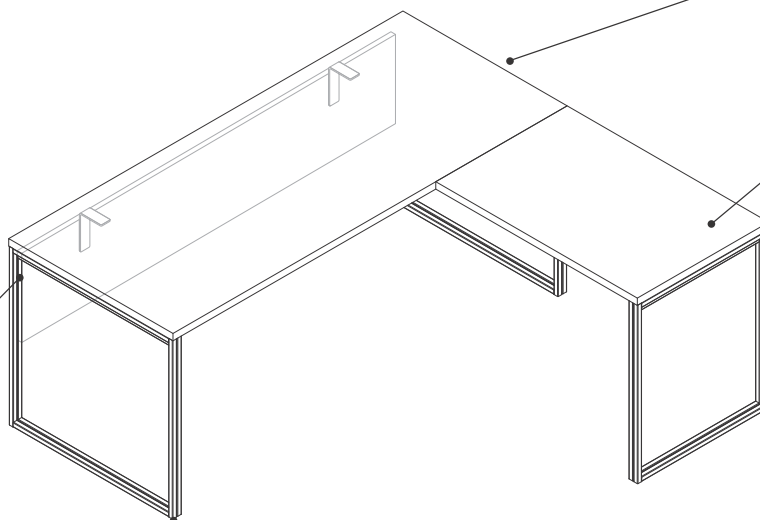


Specifying  
▶ Page 413



# Greenpoint Private Office

**Greenpoint private office** offers a contemporary take on the private office with its distinct visual language and fresh material options.



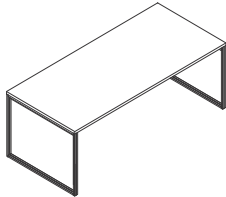
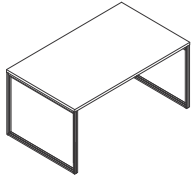
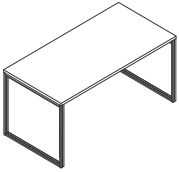
**Private desk worksur-**  
**faces** are 1 $\frac{1}{8}$ " thick. They  
are specified with High-  
Pressure Laminate. Height  
of the private desk is 29 $\frac{1}{2}$ ".

**Desk returns** are avail-  
able for private desks and  
can be specified with a leg  
support.

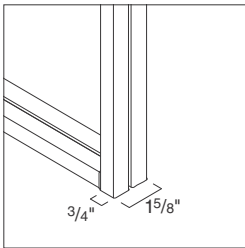
**A modesty panel** is avail-  
able and ordered separately.  
They can be specified in  
High-Pressure Laminate.  
Modesty panel can be  
mounted flush or inset.

**Leveling glides** provide  
1 $\frac{1}{2}$ " adjustment.

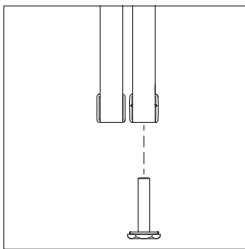
**Product Details**



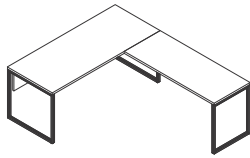
**Private desks** are available in a range of sizes and come standard with two legs. Desk returns and modesty panels are also available.



**Legs** are welded metal.

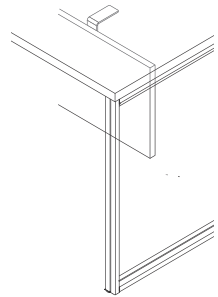
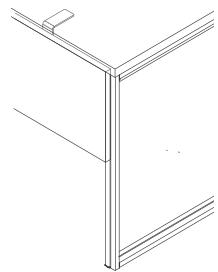


**Glide**s are adjustable and provide 1 1/2" adjustment.



**Desk returns** are used with private desks to form L-shape configurations, where everything is in reach.

**Modesty panels** cannot be used on the return side of this configuration.



**Modesty panel** can be mounted flush or inset. Height can be adjusted to provide cord pass-through.

**Surface Materials**

**Worksurface and modesty panel**

- 2409 Clear Maple
- 2410 Graphite Walnut
- 2412 Natural Cherry
- 2535 Virginia Walnut
- 2538 Clear Walnut
- 2730 Arctic White
- 2759 Warm White
- 2883 Seagull
- 2884 Milk
- 2HAK Clear Oak
- 2HAT Acacia
- 2LAW Ash Wenge
- 2HCN Clay Noce
- 2HCW Clay Wenge

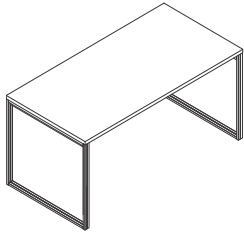
**Frame and base**

- 4799 Platinum Metallic
- 7207 Black

# West Elm Furniture

Greenpoint

## Greenpoint Private Desk



Standard Includes	Required to Specify
<ul style="list-style-type: none"> <li>▶ Need help? Product details, page 408</li> <li>• Desk worksurface: High-Pressure Laminate</li> <li>• Square tube legs (frame): paint price group 1</li> <li>• 1½" leveling glides</li> </ul>	<ol style="list-style-type: none"> <li>1 Style number</li> <li>2 Laminate color number for worksurface</li> <li>3 Paint color number for frame</li> <li>4 Options, if selected (see below)</li> </ol> <ul style="list-style-type: none"> <li>▶ See <i>Surface Materials</i>, page 506.</li> </ul>

Options	U.S. Price	Required to Specify
<b>Surface Materials</b> <ul style="list-style-type: none"> <li>• Paint price group 1</li> <li>• Paint price group 2</li> </ul>	<b>Frame</b> <ul style="list-style-type: none"> <li>• No cost</li> <li>• +\$44</li> </ul>	<ul style="list-style-type: none"> <li>Specify paint color number.</li> <li>Specify paint color number.</li> </ul>

Specification Information				
Style Number	Depth	U.S. Base Prices		
		60"	66"	72"
<b>AMQWESINDPD</b>	30"	\$2326	\$2392	\$2460

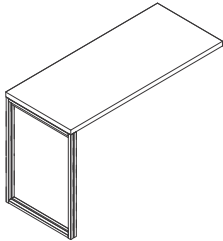


### For Canadian Pricing

Multiply U.S. Price by the Canadian price factor.

▶ See page 1 for details.

## Greenpoint Desk Return with Leg

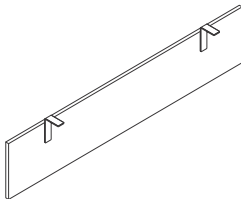


Standard Includes		Required to Specify
<ul style="list-style-type: none"> <li>▶ Need help? Product details, page 408</li> </ul>	<ul style="list-style-type: none"> <li>• Desk worksurface: High-Pressure Laminate</li> <li>• Square tube legs (frame): paint price group 1</li> <li>• 1½" leveling glides</li> </ul>	<ol style="list-style-type: none"> <li>1 Style number</li> <li>2 Laminate color number for worksurface</li> <li>3 Paint color number for frame/legs</li> <li>4 Options, if selected (see below)</li> </ol> <ul style="list-style-type: none"> <li>▶ See <i>Surface Materials</i>, page 506.</li> </ul>

Options	U.S. Price	Required to Specify
<b>Surface Materials</b> <ul style="list-style-type: none"> <li>• Paint price group 1</li> <li>• Paint price group 2</li> </ul>	<b>Frame</b> <ul style="list-style-type: none"> <li>• No cost</li> <li>• +\$20</li> </ul>	<ul style="list-style-type: none"> <li>Specify paint color number.</li> <li>Specify paint color number.</li> </ul>

Specification Information			
Style Number	Depth	U.S. Base Prices	
		42"	48"
<b>AMQWESINDRL</b>	24"	\$1285	\$1349

## Greenpoint Modesty Panel



Standard Includes		Required to Specify
<ul style="list-style-type: none"> <li>▶ Need help? Product details, page 408</li> </ul>	<ul style="list-style-type: none"> <li>• Modesty panel: High-Pressure Laminate</li> <li>• Mounting bracket: black paint</li> </ul>	<ol style="list-style-type: none"> <li>1 Style number</li> <li>2 Laminate color number for modesty panel</li> </ol> <ul style="list-style-type: none"> <li>▶ See <i>Surface Materials</i>, page 506.</li> </ul>

Specification Information			
Style Number	Depth	U.S. Prices	
		60"	66" : 72"
<b>AMQWESINDMP</b>	12½"	\$548	\$579 : \$605

 **For Canadian Pricing**  
 Multiply U.S. Price by the Canadian price factor.  
 ▶ See page 1 for details.

# Greenpoint Private Office

## Accessories

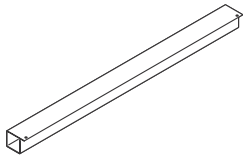
### Wire Clips



	Standard Includes	Required to Specify
▶ Need help? Product details, page 408	<ul style="list-style-type: none"> <li>• Carton of six wire clips: black plastic only</li> <li>• Foam tape</li> <li>• Mounting screws</li> </ul>	Style number

Specification Information	
• Style Number	• U.S. Price
<b>AMQ999CHT</b>	\$115
•	•

### Wire Manager



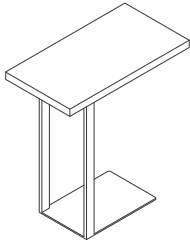
	Standard Includes	Required to Specify
▶ Need help? Product details, page 408	<ul style="list-style-type: none"> <li>• Wire manager: 6000 Black</li> <li>• Attachment hardware</li> </ul>	Style number

Specification Information					
• Dimensions			• Weight	• Style Number	• U.S. Price
D	W	H			
1¾"	30"	1¾"	0.56 lb	<b>AMQAWM30</b>	\$76
•	•	•	•	•	•



**For Canadian Pricing**  
Multiply U.S. Price by the  
Canadian price factor.  
▶ See page 1 for details.

## Linear Personal Table



Standard Includes	Required to Specify
<ul style="list-style-type: none"> <li>Table: natural oak</li> </ul>	Style number

Specification Information				
Dimensions			Style	U.S.
D	W	H	Number	Price
13½"	24"	26½"	<b>AMQWEM8</b>	\$728



 **For Canadian Pricing**  
 Multiply U.S. Price by the Canadian price factor.  
 ▶ See page 1 for details.



---

# AMQ Seating

<b>JAKU</b>	<b>417</b>
<b>ZILO</b>	<b>425</b>
<b>PERSONALITY PLUS</b>	<b>437</b>
<b>BODI</b>	<b>443</b>
<b>FL-X</b>	<b>447</b>
<b>TIZU</b>	<b>451</b>
<b>BRIN</b>	<b>457</b>
<b>WEST ELM SEATING</b>	<b>461</b>



---

# JAKU



**Understanding**

**418**



**Specifying**

**419**

## Jaku Features

---

Frame available in White and Black

---

Base available in Polished Aluminum, White and Black

---

Removable Seat Covers

---

Smart Sync Mechanism with Variable Back Stop with Tension Adjustment

---

Step Sync Mech with Multi-Position Back Lock and Tension Knob

---

3-Way Adjustable or Fixed Arms

---

Adjustable Lumbar Support

---

Seat Depth Adjustment (seat slider)

---

Waterfall Seat Design

---

Fully Assembled option

---



## Jaku Specifications

Weight Capacity	275 lbs
Net Weight	38 lbs
Back Dimensions	18.25"w x 22"h
Seat Dimensions	19.25"w x 19.75"d
Seat Height	17" - 20.25"
Back Height	39.25" - 42.5"
Arms Span (outside edges)	24.25" - 26.75"
Adjustable Seat Depth	16.5" - 17.75"
Base Width	27"
Body Frame Material	Nylon
Base Materials	Polished Aluminum and Nylon
Cushion Seats	Polyurethane fill
Seat Covers	Removable with velcro closure
Mesh Back Material	Polyester
Castors	Soft* (Black or White/Grey)
Certifications	ANSI/BIFMA X5.1-2017 TB117-2013 Indoor Advantage Gold™



Tip: Illustration above shows a fully assembled chair which is not included in the base price.

Tip: Illustration above shows chair with arms, which is not included in the base price.

Tip: The step sync mechanism and step sync cylinder options will be culled October 18, 2026.

Standard Includes		Required to Specify	
<ul style="list-style-type: none"> <li>• 3¼" pneumatic seat-height adjustment (17.0"–20.25")</li> <li>• Plastic frame</li> <li>• Plastic base</li> <li>• Seat depth adjustment (seat slider)</li> <li>• Fabric price group 1 on seat</li> <li>• Removable seat covers with velcro closure</li> <li>• Armless</li> <li>• Adjustable lumbar support</li> <li>• Mesh back</li> <li>• Step Sync mechanism with multi-position back lock and tension knob: black</li> <li>• 2½" diameter, soft-composition, dual-wheel black casters</li> </ul>		<ol style="list-style-type: none"> <li>1 Style number</li> <li>2 Fabric color number for seat</li> <li>3 Color number for frame</li> <li>4 Color number for base</li> <li>5 Options, if selected (see below)</li> </ol> <p>▶ See <i>Surface Materials</i>, page 508.</p>	

	Options	U.S. Price	Required to Specify
<b>Surface Materials</b>	<b>Back frame</b>		
	• Black frame	No cost	Specify with <i>black frame</i> .
	• White frame	+\$ 12	Specify with <i>white frame</i> .
	<b>Back</b>		
	• Fabric price group 1	No cost	Specify fabric color number.
	<b>Seat cover</b>		
	• Fabric price group 1	No cost	Specify fabric color number.
	• Fabric price group 2	+\$ 21	Specify fabric color number.
	• Vinyl price group 2	+\$ 21	Specify vinyl color number.
	• Fabric price group 3	+\$ 42	Specify fabric color number.
• Polyurethane	+\$ 74	Specify polyurethane color number.	
<b>Seat shell</b>			
• Black plastic seat shell	No cost	Specify with <i>black plastic seat shell</i> .	
• Grey plastic seat shell	+\$ 8	Specify with <i>grey plastic seat shell</i> .	
<b>Base</b>			
• Black base	No cost	Specify with <i>black base</i> .	
• White base	+\$ 13	Specify with <i>white base</i> .	
• Polished aluminum base	+\$ 33	Specify with <i>polished aluminum base</i> .	
<b>Arms</b>			
• Armless	No cost	Specify with <i>no arms</i> .	
• Fixed, black	+\$ 90	Specify with <i>fixed black arms</i> .	
• Fixed, white	+\$ 95	Specify with <i>fixed white arms</i> .	
• 3-way adjustable, black	+\$137	Specify with <i>3-way adjustable black arms</i> .	
• 3-way adjustable, white	+\$142	Specify with <i>3-way adjustable white arms</i> .	
<b>Mechanism</b>			
• Step sync mechanism, black X10/26	No cost	Specify with <i>black step sync mechanism</i> .	
• Smart sync mechanism, black	+\$ 68	Specify with <i>black smart sync mechanism</i> .	
• Smart sync mechanism, grey	+\$ 69	Specify with <i>grey smart sync mechanism</i> .	
<b>Cylinder</b>			
• Smart sync cylinder, chrome	No cost	Specify with <i>chrome smart sync cylinder</i> .	
• Smart sync cylinder, black	No cost	Specify with <i>black smart sync cylinder</i> .	
• Smart sync cylinder, white	No cost	Specify with <i>white smart sync cylinder</i> .	
• Step sync cylinder, black X10/26	No cost	Specify with <i>black step sync cylinder</i> .	
• Step sync cylinder, chrome X10/26	No cost	Specify with <i>chrome step sync cylinder</i> .	
• Step sync cylinder, white X10/26	No cost	Specify with <i>white step sync cylinder</i> .	
<b>Casters or Glides</b>			
• Soft, black	No cost	Specify with <i>black soft casters/glides</i> .	
• Soft, 2-tone grey	+\$ 5	Specify with <i>2-tone grey soft casters/glides</i> .	
<b>Packaging</b>			
• Knocked down	No cost	Specify knocked down.	
• Fully assembled	+\$ 98	Specify fully assembled.	

### Specification Information

Style Number	U.S. Base Price
JAKUCHAIR	\$749

X10/26 = Last order entry  
October 18, 2026

 **For Canadian Pricing**  
Multiply U.S. Price by the Canadian price factor.  
▶ See page 1 for details.

# JAKU Pre-Configured Chairs

## Pre-Configured Chair



Tip: Illustration above shows a fully assembled chair which is not included in the base price.

Tip: This pre-configured chair includes: Smart Sync mechanism, 3-way adjustable arms, polished aluminum base, and white/grey casters.

Standard Includes	Required to Specify
<ul style="list-style-type: none"> <li>• Seat cover: fabric price group 1</li> <li>• 3¼" pneumatic seat-height adjustment (17.0"-20.25")</li> <li>• Adjustable lumbar support</li> <li>• Backrest: white with grey mesh</li> <li>• Smart Sync mechanism with tension dial and variable back stop</li> <li>• 3-way adjustable arms</li> <li>• 2½" diameter, soft-composition, dual-wheel white/grey casters</li> <li>• Polished aluminum base</li> </ul>	<ol style="list-style-type: none"> <li>1 Style number</li> <li>2 Fabric color number for seat</li> <li>3 Paint number for frame</li> <li>4 Options, if selected (see below)</li> </ol> <p>▶ See <i>Surface Materials</i>, page 508.</p>

Options	U.S. Price	Required to Specify
<b>Surface Materials</b> <ul style="list-style-type: none"> <li>• <b>Seat cover</b></li> <li>• Fabric price group 1</li> <li>• Fabric price group 2</li> <li>• Vinyl price group 2</li> <li>• Fabric price group 3</li> <li>• Polyurethane</li> </ul>	<ul style="list-style-type: none"> <li>No cost</li> <li>+\$21</li> <li>+\$21</li> <li>+\$42</li> <li>+\$75</li> </ul>	<ul style="list-style-type: none"> <li>Specify fabric color number.</li> <li>Specify fabric color number.</li> <li>Specify vinyl color number.</li> <li>Specify fabric color number.</li> <li>Specify polyurethane color number.</li> </ul>
<b>Packaging</b> <ul style="list-style-type: none"> <li>• Knocked down</li> <li>• Fully assembled</li> </ul>	<ul style="list-style-type: none"> <li>No cost</li> <li>+\$98</li> </ul>	<ul style="list-style-type: none"> <li>Specify knocked down.</li> <li>Specify fully assembled.</li> </ul>

Specification Information	
Style Number	U.S. Base Price
JAKU001	\$1019

## Pre-Configured Chair ✕10/26




Tip: Illustration above shows a fully assembled chair which is not included in the base price.

Tip: This pre-configured chair includes: Step Sync mechanism, 3-way adjustable arms, polished aluminum base, and white/grey casters.

Standard Includes	Required to Specify
<ul style="list-style-type: none"> <li>• Seat cover: fabric price group 1</li> <li>• 3¼" pneumatic seat-height adjustment (17.0"-20.25")</li> <li>• Adjustable lumbar support</li> <li>• Backrest: white with grey mesh</li> <li>• Step Sync mechanism with multi-position back lock and tension knob</li> <li>• 3-way adjustable arms</li> <li>• 2½" diameter, soft-composition, dual-wheel white/grey casters</li> <li>• Polished aluminum base</li> </ul>	<ol style="list-style-type: none"> <li>1 Style number</li> <li>2 Fabric color number for seat</li> <li>3 Paint number for frame</li> <li>4 Options, if selected (see below)</li> </ol> <p>▶ See <i>Surface Materials</i>, page 508.</p>

Options	U.S. Price	Required to Specify
<b>Surface Materials</b> <ul style="list-style-type: none"> <li>• <b>Seat cover</b></li> <li>• Fabric price group 1</li> <li>• Fabric price group 2</li> <li>• Vinyl price group 2</li> <li>• Fabric price group 3</li> <li>• Polyurethane</li> </ul>	<ul style="list-style-type: none"> <li>No cost</li> <li>+\$21</li> <li>+\$21</li> <li>+\$42</li> <li>+\$75</li> </ul>	<ul style="list-style-type: none"> <li>Specify fabric color number.</li> <li>Specify fabric color number.</li> <li>Specify vinyl color number.</li> <li>Specify fabric color number.</li> <li>Specify polyurethane color number.</li> </ul>
<b>Packaging</b> <ul style="list-style-type: none"> <li>• Knocked down</li> <li>• Fully assembled</li> </ul>	<ul style="list-style-type: none"> <li>No cost</li> <li>+\$98</li> </ul>	<ul style="list-style-type: none"> <li>Specify knocked down.</li> <li>Specify fully assembled.</li> </ul>

Specification Information	
Style Number	U.S. Base Price
JAKU002 <span style="color: #e91e63;">✕10/26</span>	\$950

 **For Canadian Pricing**  
 Multiply U.S. Price by the Canadian price factor.  
 ▶ See page 1 for details.

✕10/26 = Last order entry  
 October 18, 2026

## Pre-Configured Chair



Tip: Illustration above shows a fully assembled chair which is not included in the base price.

Tip: This pre-configured chair includes: Smart Sync mechanism, 3-way adjustable arms, white base, and white/grey casters.

Standard Includes		Required to Specify	
<ul style="list-style-type: none"> <li>• Seat cover: fabric price group 1</li> <li>• 3¼" pneumatic seat-height adjustment (17.0"–20.25")</li> <li>• Adjustable lumbar support</li> <li>• Backrest: white with grey mesh</li> <li>• Smart Sync mechanism with tension dial and variable back stop</li> <li>• 3-way adjustable arms</li> <li>• 2½" diameter, soft-composition, dual-wheel white/grey casters</li> <li>• White base</li> </ul>		<ul style="list-style-type: none"> <li>1 Style number</li> <li>2 Fabric color number for seat</li> <li>3 Paint number for frame</li> <li>4 Options, if selected (see below)</li> <li>▶ See <i>Surface Materials</i>, page 508.</li> </ul>	
Options	U.S. Price	Required to Specify	
<b>Surface Materials</b>	<b>Seat cover</b>	Specify fabric color number.	
	• Fabric price group 1	No cost	Specify fabric color number.
	• Fabric price group 2	+\$21	Specify vinyl color number.
	• Vinyl price group 2	+\$21	Specify fabric color number.
	• Fabric price group 3	+\$42	Specify polyurethane color number.
	• Polyurethane	+\$75	
<b>Packaging</b>	• Knocked down	No cost	Specify knocked down.
	• Fully assembled	+\$98	Specify fully assembled.

Specification Information	
Style Number	U.S. Base Price
JAKU003	\$999

## Pre-Configured Chair



Tip: Illustration above shows a fully assembled chair which is not included in the base price.

Tip: This pre-configured chair includes: Smart Sync mechanism, 3-way adjustable arms, polished aluminum base, and black casters.

Standard Includes		Required to Specify	
<ul style="list-style-type: none"> <li>• Seat cover: fabric price group 1</li> <li>• 3¼" pneumatic seat-height adjustment (17.0"–20.25")</li> <li>• Adjustable lumbar support</li> <li>• Backrest: black with black mesh</li> <li>• Smart Sync mechanism with tension dial and variable back stop</li> <li>• 3-way adjustable arms</li> <li>• 2½" diameter, soft-composition, dual-wheel black casters</li> <li>• Polished aluminum base</li> </ul>		<ul style="list-style-type: none"> <li>1 Style number</li> <li>2 Fabric color number for seat</li> <li>3 Paint number for frame</li> <li>4 Options, if selected (see below)</li> <li>▶ See <i>Surface Materials</i>, page 508.</li> </ul>	
Options	U.S. Price	Required to Specify	
<b>Surface Materials</b>	<b>Seat cover</b>	Specify fabric color number.	
	• Fabric price group 1	No cost	Specify fabric color number.
	• Fabric price group 2	+\$21	Specify vinyl color number.
	• Vinyl price group 2	+\$21	Specify fabric color number.
	• Fabric price group 3	+\$42	Specify polyurethane color number.
	• Polyurethane	+\$75	
<b>Packaging</b>	• Knocked down	No cost	Specify knocked down.
	• Fully assembled	+\$98	Specify fully assembled.

Specification Information	
Style Number	U.S. Base Price
JAKU004	\$989

 **For Canadian Pricing**  
Multiply U.S. Price by the Canadian price factor.  
▶ See page 1 for details.

**Pre-Configured Chair** **10/26**



*Tip: Illustration above shows a fully assembled chair which is not included in the base price.*

*Tip: This pre-configured chair includes: Step Sync mechanism, 3-way adjustable arms, polished aluminum base, and black casters.*

Standard Includes		Required to Specify	
<ul style="list-style-type: none"> <li>• Seat cover: fabric price group 1</li> <li>• 3¼" pneumatic seat-height adjustment (17.0"–20.25")</li> <li>• Adjustable lumbar support</li> <li>• Backrest: black with black mesh</li> <li>• Step Sync mechanism with multi-position back lock and tension knob</li> <li>• 3-way adjustable arms</li> <li>• 2½" diameter, soft-composition, dual-wheel black casters</li> <li>• Polished aluminum base</li> </ul>		<ol style="list-style-type: none"> <li>1 Style number</li> <li>2 Fabric color number for seat</li> <li>3 Paint number for frame</li> <li>4 Options, if selected (see below)</li> </ol> <p>▶ See <i>Surface Materials</i>, page 508.</p>	
Options		U.S. Price	Required to Specify
<b>Surface Materials</b>	<b>Seat cover</b> <ul style="list-style-type: none"> <li>• Fabric price group 1</li> <li>• Fabric price group 2</li> <li>• Vinyl price group 2</li> <li>• Fabric price group 3</li> <li>• Polyurethane</li> </ul>	No cost +\$21 +\$21 +\$42 +\$75	Specify fabric color number. Specify fabric color number. Specify vinyl color number. Specify fabric color number. Specify polyurethane color number.
<b>Packaging</b>	<ul style="list-style-type: none"> <li>• Knocked down</li> <li>• Fully assembled</li> </ul>	No cost +\$98	Specify knocked down. Specify fully assembled.
Specification Information			
<b>Style Number</b>	<b>U.S. Base Price</b>		
JAKU005 <b>10/26</b>	\$919		

**Pre-Configured Chair**



*Tip: Illustration above shows a fully assembled chair which is not included in the base price.*

*Tip: This pre-configured chair includes: Smart Sync mechanism, 3-way adjustable arms, black base, and black casters.*

Standard Includes		Required to Specify	
<ul style="list-style-type: none"> <li>• Seat cover: fabric price group 1</li> <li>• 3¼" pneumatic seat-height adjustment (17.0"–20.25")</li> <li>• Adjustable lumbar support</li> <li>• Backrest: black with black mesh</li> <li>• Smart Sync mechanism with tension dial and variable back stop</li> <li>• 3-way adjustable arms</li> <li>• 2½" diameter, soft-composition, dual-wheel black casters</li> <li>• Black base</li> </ul>		<ol style="list-style-type: none"> <li>1 Style number</li> <li>2 Fabric color number for seat</li> <li>3 Paint number for frame</li> <li>4 Options, if selected (see below)</li> </ol> <p>▶ See <i>Surface Materials</i>, page 508.</p>	
Options		U.S. Price	Required to Specify
<b>Surface Materials</b>	<b>Seat cover</b> <ul style="list-style-type: none"> <li>• Fabric price group 1</li> <li>• Fabric price group 2</li> <li>• Vinyl price group 2</li> <li>• Fabric price group 3</li> <li>• Polyurethane</li> </ul>	No cost +\$21 +\$21 +\$42 +\$75	Specify fabric color number. Specify fabric color number. Specify vinyl color number. Specify fabric color number. Specify polyurethane color number.
<b>Packaging</b>	<ul style="list-style-type: none"> <li>• Knocked down</li> <li>• Fully assembled</li> </ul>	No cost +\$98	Specify knocked down. Specify fully assembled.
Specification Information			
<b>Style Number</b>	<b>U.S. Base Price</b>		
JAKU006	\$954		



**For Canadian Pricing**  
 Multiply U.S. Price by the Canadian price factor.  
 ▶ See page 1 for details.

**10/26** = Last order entry  
 October 18, 2026

## Pre-Configured Chair



Tip: Illustration above shows a fully assembled chair which is not included in the base price.

Tip: This pre-configured chair includes: Smart Sync mechanism, fixed arms, polished aluminum base, and white/grey casters.

Standard Includes		Required to Specify	
	<ul style="list-style-type: none"> <li>• Seat cover: fabric price group 1</li> <li>• 3¼" pneumatic seat-height adjustment (17.0"–20.25")</li> <li>• Adjustable lumbar support</li> <li>• Backrest: white with grey mesh</li> <li>• Smart Sync mechanism with tension dial and variable back stop</li> <li>• Fixed arms</li> <li>• 2½" diameter, soft-composition, dual-wheel white/grey casters</li> <li>• Polished aluminum base</li> </ul>		<ul style="list-style-type: none"> <li>1 Style number</li> <li>2 Fabric color number for seat</li> <li>3 Paint number for frame</li> <li>4 Options, if selected (see below)</li> <li>▶ See <i>Surface Materials</i>, page 508.</li> </ul>
Options	U.S. Price	Required to Specify	
<b>Surface Materials</b>	<b>Seat cover</b> <ul style="list-style-type: none"> <li>• Fabric price group 1</li> <li>• Fabric price group 2</li> <li>• Vinyl price group 2</li> <li>• Fabric price group 3</li> <li>• Polyurethane</li> </ul>	No cost +\$21 +\$21 +\$42 +\$75	Specify fabric color number. Specify fabric color number. Specify vinyl color number. Specify fabric color number. Specify polyurethane color number.
<b>Packaging</b>	<ul style="list-style-type: none"> <li>• Knocked down</li> <li>• Fully assembled</li> </ul>	No cost +\$98	Specify knocked down. Specify fully assembled.

Specification Information	
Style Number	U.S. Base Price
JAKU007	\$972

## Pre-Configured Chair



Tip: Illustration above shows a fully assembled chair which is not included in the base price.

Tip: This pre-configured chair includes: Smart Sync mechanism, fixed arms, polished aluminum base, and black casters.

Standard Includes		Required to Specify	
	<ul style="list-style-type: none"> <li>• Seat cover: fabric price group 1</li> <li>• 3¼" pneumatic seat-height adjustment (17.0"–20.25")</li> <li>• Adjustable lumbar support</li> <li>• Backrest: black with black mesh</li> <li>• Smart Sync mechanism with tension dial and variable back stop</li> <li>• Fixed arms</li> <li>• 2½" diameter, soft-composition, dual-wheel black casters</li> <li>• Polished aluminum base</li> </ul>		<ul style="list-style-type: none"> <li>1 Style number</li> <li>2 Fabric color number for seat</li> <li>3 Paint number for frame</li> <li>4 Options, if selected (see below)</li> <li>▶ See <i>Surface Materials</i>, page 508.</li> </ul>
Options	U.S. Price	Required to Specify	
<b>Surface Materials</b>	<b>Seat cover</b> <ul style="list-style-type: none"> <li>• Fabric price group 1</li> <li>• Fabric price group 2</li> <li>• Vinyl price group 2</li> <li>• Fabric price group 3</li> <li>• Polyurethane</li> </ul>	No cost +\$21 +\$21 +\$42 +\$75	Specify fabric color number. Specify fabric color number. Specify vinyl color number. Specify fabric color number. Specify polyurethane color number.
<b>Packaging</b>	<ul style="list-style-type: none"> <li>• Knocked down</li> <li>• Fully assembled</li> </ul>	No cost +\$98	Specify knocked down. Specify fully assembled.

Specification Information	
Style Number	U.S. Base Price
JAKU008	\$940

 **For Canadian Pricing**  
Multiply U.S. Price by the Canadian price factor.  
▶ See page 1 for details.

# JAKU Seat Cover



Standard Includes	Required to Specify
<ul style="list-style-type: none"> <li>• Seat cover, fabric price group 1</li> </ul>	1 Style number 2 Fabric color number for seat cover 3 Options, if selected (see below) ▶ See <i>Surface Materials</i> , page 508.

Options	U.S. Price	Required to Specify
<b>Surface Materials</b> <b>Seat cover</b> <ul style="list-style-type: none"> <li>• Fabric price group 2</li> <li>• Vinyl price group 2</li> <li>• Fabric price group 3</li> <li>• Polyurethane</li> </ul>	+\$21 +\$21 +\$42 +\$74	Specify fabric color number. Specify vinyl color number. Specify fabric color number. Specify polyurethane color number.

Specification Information	
Style Number	U.S. Base Price
JAKUSEATCOVER	\$68



**For Canadian Pricing**  
 Multiply U.S. Price by the Canadian price factor.  
 ▶ See page 1 for details.

---

# ZILO

<b>Understanding</b>	<b>426</b>
<b>Specifying</b>	<b>427</b>

## Zilo Features

Choose from standard configurations or customize your own

Available in Black, White or All Mesh

Choose from Mid or High Back

Full Syncro Mechanism with Tension Adjuster

2 Position Lock with Sliding Seat Mechanism

3-way Adjustable or Fixed Loop Arm styles

Adjustable Lumbar Support

Removable Seat Covers in 2 material options (fabric and polyurethane)



## Zilo Specifications

Weight Capacity	275 lbs
Net Weight	38 lbs
Height Range	39.5" - 43.5"
High Back Dimensions	18"w x 21.5"h
Mid-Back Dimensions	18"w x 18.5"h
Seat Dimensions	19.25"w x 20"d
Seat Height Range	18.5" - 22.75"
Arms Span (outside edges)	25.25" - 26.5"
Body Frame Material	Nylon
Base Materials	Polished Aluminum and Nylon
Base Width	Nylon: 27" / Polished Aluminum: 27.5"
Cushion Seats	Polyurethane fill
Seat Covers	Removable with velcro closure
Mesh Back Material	Polyester/Polyelastomer/Nylon
Castors	Soft* PU (Black or White/Grey)
Certifications	ANSI/BIFMA X5.1-2017 TB117-2013 Indoor Advantage Gold™



Tip: Illustration above shows a fully assembled chair which is not included in the base price.

Tip: Illustration above shows chair with arms, which is not included in the base price.

Tip: When the all mesh option is selected, a seat cover is not specified. Please refer to the electronic catalog or SmartTools for pricing.

Tip: The black all mesh options will be culled October 18, 2026.

Standard Includes	Required to Specify
<ul style="list-style-type: none"> <li>• Seat: fabric price group 1</li> <li>• Seat shell: black plastic</li> <li>• 4 1/4" pneumatic seat-height adjustment (18 1/2"-22 3/4")</li> <li>• Frame: black plastic</li> <li>• Base: black plastic</li> <li>• Seat depth adjustment (seat slider)</li> <li>• Removable seat covers with velcro closure</li> <li>• Armless</li> <li>• Adjustable lumbar support</li> <li>• Mesh back: fabric</li> <li>• Synchronized mechanism with tension adjustment</li> <li>• 2 1/2" diameter, soft-composition, dual-wheel black casters</li> </ul>	<ol style="list-style-type: none"> <li>1 Style number</li> <li>2 Fabric color number for seat</li> <li>3 Fabric color number for back</li> <li>4 Options, if selected (see below)</li> </ol> <p>▶ See <i>Surface Materials</i>, page 508.</p>

Options	U.S. Price	Required to Specify
<b>Surface Materials</b>		
<b>Back frame</b>		
• Mid back–black, 22 1/2" high	No cost	Specify with mid back–black, 22 1/2" high.
• Mid back–white, 22 1/2" high	+\$ 12	Specify with mid back–white, 22 1/2" high.
• High back–black, 26" high	+\$ 56	Specify with high back–black, 26" high.
• High back–black mesh for mesh seat <b>‡10/26</b>	+\$ 56	Specify with high back–black mesh for mesh seat.
• High back–white, 26" high	+\$ 68	Specify with high back–white, 26" high.
<b>Seat cover</b>		
• Fabric price group 1	No cost	Specify fabric color number.
• Fabric price group 2	+\$ 21	Specify fabric color number.
• Vinyl price group 2	+\$ 21	Specify vinyl color number.
• Fabric price group 3	+\$ 42	Specify fabric color number.
• Polyurethane	+\$ 74	Specify polyurethane color number.
<b>Seat shell</b>		
• Black plastic seat shell	No cost	Specify with black plastic seat shell.
• White plastic seat shell	+\$ 7	Specify with white plastic seat shell.
• Black shell, for all mesh chair <b>‡10/26</b>	+\$ 69	Specify with black shell, for all mesh chair.
<b>Base</b>		
• Black base	No cost	Specify with black base.
• White base	+\$ 15	Specify with white base.
• Polished aluminum base	+\$ 35	Specify with polished aluminum base.
<b>Arm</b>		
• Armless	No cost	Specify with armless.
• Fixed loop, black	+\$ 76	Specify with fixed loop, black.
• Fixed loop, white	+\$ 82	Specify with fixed loop, white.
• 3-way adjustable, black	+\$115	Specify with 3-way adjustable, black.
• 3-way adjustable, white	+\$123	Specify with 3-way adjustable, white.
<b>Mechanism</b>		
• Synchro with tension adjust	No cost	Specify with synchro with tension adjust.
• Swivel, draft ring with extension cylinder	+\$188	Specify with swivel, draft ring with extension cylinder.
<b>Caster</b>		
• Soft, black	No cost	Specify with soft, black.
• Soft, 2-tone grey	+\$ 5	Specify with soft, 2-tone grey.
<b>Packaging</b>		
• Knocked down	No cost	Specify with knocked down.
• Fully assembled	+\$ 98	Specify with fully assembled.

Specification Information	
Style Number	U.S. Base Price
ZILOCHAIR	\$683

**For Canadian Pricing**  
 Multiply U.S. Price by the Canadian price factor.  
 ▶ See page 1 for details.

**‡10/26** = Last order entry  
 October 18, 2026



# ZILO Pre-Configured Chair

## Pre-Configured Chair



Tip: Illustration above shows a fully assembled chair which is not included in the base price.

Tip: This pre-configured chair includes: synchronized mechanism, mesh back, 3-way adjustable arms, polished aluminum base, and white casters.

Standard Includes	Required to Specify
<ul style="list-style-type: none"> <li>• Seat: fabric price group 1</li> <li>• 4 1/4" pneumatic seat-height adjustment (18 1/2"-22 3/4")</li> <li>• Adjustable lumbar support</li> <li>• Synchronized mechanism with tension adjustment</li> <li>• High backrest: white with grey mesh</li> <li>• 3-way adjustable arms</li> <li>• 2 1/2" diameter, soft-composition, dual-wheel white casters</li> <li>• Polished aluminum base</li> </ul>	<ul style="list-style-type: none"> <li>1 Style number</li> <li>2 Fabric color number for seat</li> <li>3 Options, if selected (see below)</li> <li>▶ See <i>Surface Materials</i>, page 508.</li> </ul>

Options	U.S. Price	Required to Specify
<b>Surface Materials</b> <ul style="list-style-type: none"> <li>• <b>Seat cover</b></li> <li>• Fabric price group 1</li> <li>• Fabric price group 2</li> <li>• Vinyl price group 2</li> <li>• Fabric price group 3</li> <li>• Polyurethane</li> </ul>	<ul style="list-style-type: none"> <li>No cost</li> <li>+\$21</li> <li>+\$21</li> <li>+\$42</li> <li>+\$75</li> </ul>	<ul style="list-style-type: none"> <li>Specify fabric color number.</li> <li>Specify fabric color number.</li> <li>Specify vinyl color number.</li> <li>Specify fabric color number.</li> <li>Specify polyurethane color number.</li> </ul>
<b>Packaging</b> <ul style="list-style-type: none"> <li>• Knocked down</li> <li>• Fully assembled</li> </ul>	<ul style="list-style-type: none"> <li>No cost</li> <li>+\$98</li> </ul>	<ul style="list-style-type: none"> <li>Specify <i>with knocked down</i>.</li> <li>Specify <i>with fully assembled</i>.</li> </ul>

Specification Information	
• Style Number	• U.S. Base Price
ZILO001	\$922
.	.
.	.



**For Canadian Pricing**  
 Multiply U.S. Price by the Canadian price factor.  
 ▶ See page 1 for details.

## Pre-Configured Chair



*Tip: Illustration above shows a fully assembled chair which is not included in the base price.*

*Tip: This pre-configured chair includes: synchronized mechanism, mesh back, 3-way adjustable arms, white base, and white casters.*

Standard Includes	Required to Specify
<ul style="list-style-type: none"> <li>• Seat: fabric price group 1</li> <li>• 4<sup>1</sup>/<sub>4</sub>" pneumatic seat-height adjustment (18<sup>1</sup>/<sub>2</sub>"–22<sup>3</sup>/<sub>4</sub>" )</li> <li>• Adjustable lumbar support</li> <li>• Synchronized mechanism with tension adjustment</li> <li>• High backrest: white with grey mesh</li> <li>• 3-way adjustable arms</li> <li>• 2<sup>1</sup>/<sub>2</sub>" diameter, soft-composition, dual-wheel white casters</li> <li>• White base</li> </ul>	<ul style="list-style-type: none"> <li>1 Style number</li> <li>2 Fabric color number for seat</li> <li>3 Options, if selected (see below)</li> <li>▶ See <i>Surface Materials</i>, page 508.</li> </ul>

Options	U.S. Price	Required to Specify
<b>Surface Materials</b> <ul style="list-style-type: none"> <li>• <b>Seat cover</b></li> <li>• Fabric price group 1</li> <li>• Fabric price group 2</li> <li>• Vinyl price group 2</li> <li>• Fabric price group 3</li> <li>• Polyurethane</li> </ul>	<ul style="list-style-type: none"> <li>No cost</li> <li>+\$21</li> <li>+\$21</li> <li>+\$42</li> <li>+\$75</li> </ul>	<ul style="list-style-type: none"> <li>Specify fabric color number.</li> <li>Specify fabric color number.</li> <li>Specify vinyl color number.</li> <li>Specify fabric color number.</li> <li>Specify polyurethane color number.</li> </ul>
<b>Packaging</b> <ul style="list-style-type: none"> <li>• Knocked down</li> <li>• Fully assembled</li> </ul>	<ul style="list-style-type: none"> <li>No cost</li> <li>+\$98</li> </ul>	<ul style="list-style-type: none"> <li>Specify <i>with knocked down</i>.</li> <li>Specify <i>with fully assembled</i>.</li> </ul>

Specification Information	
•Style •Number • • •	•U.S. •Base •Price • •
<b>ZILO002</b>	\$902
•	•

 **For Canadian Pricing**  
 Multiply U.S. Price by the Canadian price factor.  
 ▶ See page 1 for details.

**Pre-Configured Chair**



Tip: Illustration above shows a fully assembled chair which is not included in the base price.

Tip: This pre-configured chair includes: synchronized mechanism, mesh back, 3-way adjustable arms, polished aluminum base, and black casters.

Standard Includes	Required to Specify
<ul style="list-style-type: none"> <li>• Seat: fabric price group 1</li> <li>• 4 1/4" pneumatic seat-height adjustment (18 1/2"-22 3/4")</li> <li>• Adjustable lumbar support</li> <li>• Synchronized mechanism with tension adjustment</li> <li>• High backrest: black with black mesh</li> <li>• 3-way adjustable arms</li> <li>• 2 1/2" diameter, soft-composition, dual-wheel black casters</li> <li>• Polished aluminum base</li> </ul>	<ul style="list-style-type: none"> <li>1 Style number</li> <li>2 Fabric color number for seat</li> <li>3 Options, if selected (see below)</li> <li>▶ See <i>Surface Materials</i>, page 508.</li> </ul>

Options	U.S. Price	Required to Specify
<b>Surface Materials</b> <ul style="list-style-type: none"> <li>• <b>Seat cover</b></li> <li>• Fabric price group 1</li> <li>• Fabric price group 2</li> <li>• Vinyl price group 2</li> <li>• Fabric price group 3</li> <li>• Polyurethane</li> </ul>	<ul style="list-style-type: none"> <li>No cost</li> <li>+\$21</li> <li>+\$21</li> <li>+\$42</li> <li>+\$75</li> </ul>	<ul style="list-style-type: none"> <li>Specify fabric color number.</li> <li>Specify fabric color number.</li> <li>Specify vinyl color number.</li> <li>Specify fabric color number.</li> <li>Specify polyurethane color number.</li> </ul>
<b>Packaging</b> <ul style="list-style-type: none"> <li>• Knocked down</li> <li>• Fully assembled</li> </ul>	<ul style="list-style-type: none"> <li>No cost</li> <li>+\$98</li> </ul>	<ul style="list-style-type: none"> <li>Specify <i>with knocked down</i>.</li> <li>Specify <i>with fully assembled</i>.</li> </ul>

Specification Information	
Style Number	U.S. Base Price
ZILO003	\$888



**For Canadian Pricing**  
 Multiply U.S. Price by the Canadian price factor.  
 ▶ See page 1 for details.

## Pre-Configured Chair



*Tip: Illustration above shows a fully assembled chair which is not included in the base price.*

*Tip: This pre-configured chair includes: synchronized mechanism, mesh back, 3-way adjustable arms, black base, and black casters.*

Standard Includes	Required to Specify
<ul style="list-style-type: none"> <li>• Seat: fabric price group 1</li> <li>• 4<sup>1</sup>/<sub>4</sub>" pneumatic seat-height adjustment (18<sup>1</sup>/<sub>2</sub>"–22<sup>3</sup>/<sub>4</sub>" )</li> <li>• Adjustable lumbar support</li> <li>• Synchronized mechanism with tension adjustment</li> <li>• High backrest: black with black mesh</li> <li>• 3-way adjustable arms</li> <li>• 2<sup>1</sup>/<sub>2</sub>" diameter, soft-composition, dual-wheel black casters</li> <li>• Black base</li> </ul>	<ul style="list-style-type: none"> <li>1 Style number</li> <li>2 Fabric color number for seat</li> <li>3 Options, if selected (see below)</li> <li>▶ See <i>Surface Materials</i>, page 508.</li> </ul>

Options	U.S. Price	Required to Specify
<b>Surface Materials</b> <ul style="list-style-type: none"> <li>• <b>Seat cover</b></li> <li>• Fabric price group 1</li> <li>• Fabric price group 2</li> <li>• Vinyl price group 2</li> <li>• Fabric price group 3</li> <li>• Polyurethane</li> </ul>	<ul style="list-style-type: none"> <li>No cost</li> <li>+\$21</li> <li>+\$21</li> <li>+\$42</li> <li>+\$75</li> </ul>	<ul style="list-style-type: none"> <li>Specify fabric color number.</li> <li>Specify fabric color number.</li> <li>Specify vinyl color number.</li> <li>Specify fabric color number.</li> <li>Specify polyurethane color number.</li> </ul>
<b>Packaging</b> <ul style="list-style-type: none"> <li>• Knocked down</li> <li>• Fully assembled</li> </ul>	<ul style="list-style-type: none"> <li>No cost</li> <li>+\$98</li> </ul>	<ul style="list-style-type: none"> <li>Specify <i>with knocked down</i>.</li> <li>Specify <i>with fully assembled</i>.</li> </ul>

Specification Information	
Style Number	U.S. Base Price
ZILO004	\$853

ZILO

 **For Canadian Pricing**  
 Multiply U.S. Price by the Canadian price factor.  
 ▶ See page 1 for details.

**Pre-Configured Chair** ❏10/26



*Tip: Illustration above shows a fully assembled chair which is not included in the base price.*

*Tip: This pre-configured chair includes: synchronized mechanism, mesh back and seat, 3-way adjustable arms, polished aluminum base, and black casters.*

Standard Includes	Required to Specify
<ul style="list-style-type: none"> <li>• Seat: fabric price group 1</li> <li>• 4 1/4" pneumatic seat-height adjustment (18 1/2"-22 3/4")</li> <li>• Adjustable lumbar support</li> <li>• Synchronized mechanism with tension adjustment</li> <li>• Mesh back and seat</li> <li>• High backrest: black with black mesh</li> <li>• 3-way adjustable arms</li> <li>• 2 1/2" diameter, soft-composition, dual-wheel black casters</li> <li>• Polished aluminum base</li> </ul>	<ul style="list-style-type: none"> <li>1 Style number</li> <li>2 Fabric color number for seat</li> <li>3 Options, if selected (see below)</li> <li>▶ See <i>Surface Materials</i>, page 508.</li> </ul>

Options	U.S. Price	Required to Specify
<b>Packaging</b> <ul style="list-style-type: none"> <li>• Knocked down</li> <li>• Fully assembled</li> </ul>	<ul style="list-style-type: none"> <li>No cost</li> <li>+\$98</li> </ul>	<ul style="list-style-type: none"> <li>Specify <i>with knocked down</i>.</li> <li>Specify <i>with fully assembled</i>.</li> </ul>

Specification Information	
• Style Number	• U.S. Base Price
ZILO005 <span style="color: #c00000;">❏10/26</span>	\$958
.	.
.	.



**For Canadian Pricing**  
 Multiply U.S. Price by the Canadian price factor.  
 ▶ See page 1 for details.

❏10/26 = Last order entry  
 October 18, 2026

## Pre-Configured Chair



*Tip: Illustration above shows a fully assembled chair which is not included in the base price.*

*Tip: This pre-configured chair includes: synchronized mechanism, mesh back, fixed loop arms, polished aluminum base, and white casters.*

Standard Includes	Required to Specify
<ul style="list-style-type: none"> <li>• Seat: fabric price group 1</li> <li>• 4<sup>1</sup>/<sub>4</sub>" pneumatic seat-height adjustment (18<sup>1</sup>/<sub>2</sub>"–22<sup>3</sup>/<sub>4</sub>")</li> <li>• Adjustable lumbar support</li> <li>• Synchronized mechanism with tension adjustment</li> <li>• High backrest: white with grey mesh</li> <li>• Fixed loop arms</li> <li>• 2<sup>1</sup>/<sub>2</sub>" diameter, soft-composition, dual-wheel white casters</li> <li>• Polished aluminum base</li> </ul>	<ul style="list-style-type: none"> <li>1 Style number</li> <li>2 Fabric color number for seat</li> <li>3 Options, if selected (see below)</li> <li>▶ See <i>Surface Materials</i>, page 508.</li> </ul>

Options	U.S. Price	Required to Specify
<b>Surface Materials</b> <ul style="list-style-type: none"> <li>• <b>Seat cover</b></li> <li>• Fabric price group 1</li> <li>• Fabric price group 2</li> <li>• Vinyl price group 2</li> <li>• Fabric price group 3</li> <li>• Polyurethane</li> </ul>	<ul style="list-style-type: none"> <li>No cost</li> <li>+\$21</li> <li>+\$21</li> <li>+\$42</li> <li>+\$75</li> </ul>	<ul style="list-style-type: none"> <li>Specify fabric color number.</li> <li>Specify fabric color number.</li> <li>Specify vinyl color number.</li> <li>Specify fabric color number.</li> <li>Specify polyurethane color number.</li> </ul>
<b>Packaging</b> <ul style="list-style-type: none"> <li>• Knocked down</li> <li>• Fully assembled</li> </ul>	<ul style="list-style-type: none"> <li>No cost</li> <li>+\$98</li> </ul>	<ul style="list-style-type: none"> <li>Specify <i>with knocked down</i>.</li> <li>Specify <i>with fully assembled</i>.</li> </ul>

Specification Information	
Style Number	U.S. Base Price
ZILO006	\$881

 **For Canadian Pricing**  
 Multiply U.S. Price by the Canadian price factor.  
 ▶ See page 1 for details.

**Pre-Configured Chair**



Tip: Illustration above shows a fully assembled chair which is not included in the base price.

Tip: This pre-configured chair includes: synchronized mechanism, mesh back, fixed loop arms, polished aluminum base, and black casters.

Standard Includes	Required to Specify
<ul style="list-style-type: none"> <li>• Seat: fabric price group 1</li> <li>• 4 1/4" pneumatic seat-height adjustment (18 1/2"-22 3/4")</li> <li>• Adjustable lumbar support</li> <li>• Synchronized mechanism with tension adjustment</li> <li>• High backrest: black with black mesh</li> <li>• Fixed loop arms</li> <li>• 2 1/2" diameter, soft-composition, dual-wheel black casters</li> <li>• Polished aluminum base</li> </ul>	<ul style="list-style-type: none"> <li>1 Style number</li> <li>2 Fabric color number for seat</li> <li>3 Options, if selected (see below)</li> <li>▶ See <i>Surface Materials</i>, page 508.</li> </ul>

	Options	U.S. Price	Required to Specify
<b>Surface Materials</b>	<b>Seat cover</b>		
	• Fabric price group 1	No cost	Specify fabric color number.
	• Fabric price group 2	+\$21	Specify fabric color number.
	• Vinyl price group 2	+\$21	Specify vinyl color number.
	• Fabric price group 3	+\$42	Specify fabric color number.
	• Polyurethane	+\$75	Specify polyurethane color number.
<b>Packaging</b>	• Knocked down	No cost	Specify <i>with knocked down</i> .
	• Fully assembled	+\$98	Specify <i>with fully assembled</i> .

Specification Information	
Style Number	U.S. Base Price
ZILO007	\$849



**For Canadian Pricing**  
 Multiply U.S. Price by the Canadian price factor.  
 ▶ See page 1 for details.

## Pre-Configured Stool



*Tip: Illustration above shows a fully assembled chair which is not included in the base price.*

*Tip: This pre-configured chair includes: swivel mechanism, mesh back, swivel, fixed loop arms, polished aluminum base, and white casters.*

Standard Includes	Required to Specify
<ul style="list-style-type: none"> <li>• Seat: fabric price group 1</li> <li>• 4<sup>1</sup>/<sub>4</sub>" pneumatic seat-height adjustment (18<sup>1</sup>/<sub>2</sub>"–22<sup>3</sup>/<sub>4</sub>")</li> <li>• Adjustable lumbar support</li> <li>• Mid-backrest: white with grey mesh</li> <li>• Fixed loop arms</li> <li>• Swivel, drafting ring with extended cylinder</li> <li>• 2<sup>1</sup>/<sub>2</sub>" diameter, soft-composition, dual-wheel white casters</li> <li>• Polished aluminum base</li> </ul>	<ul style="list-style-type: none"> <li>1 Style number</li> <li>2 Fabric color number for seat</li> <li>3 Options, if selected (see below)</li> <li>▶ See <i>Surface Materials</i>, page 508.</li> </ul>

Options	U.S. Price	Required to Specify
<b>Surface Materials</b> <ul style="list-style-type: none"> <li>• <b>Seat cover</b></li> <li>• Fabric price group 1</li> <li>• Fabric price group 2</li> <li>• Vinyl price group 2</li> <li>• Fabric price group 3</li> <li>• Polyurethane</li> </ul>	<ul style="list-style-type: none"> <li>No cost</li> <li>+\$21</li> <li>+\$21</li> <li>+\$42</li> <li>+\$75</li> </ul>	<ul style="list-style-type: none"> <li>Specify fabric color number.</li> <li>Specify fabric color number.</li> <li>Specify vinyl color number.</li> <li>Specify fabric color number.</li> <li>Specify polyurethane color number.</li> </ul>
<b>Packaging</b> <ul style="list-style-type: none"> <li>• Knocked down</li> <li>• Fully assembled</li> </ul>	<ul style="list-style-type: none"> <li>No cost</li> <li>+\$98</li> </ul>	<ul style="list-style-type: none"> <li>Specify <i>with knocked down</i>.</li> <li>Specify <i>with fully assembled</i>.</li> </ul>

Specification Information	
Style Number	U.S. Base Price
ZILO008	\$1013



**For Canadian Pricing**  
 Multiply U.S. Price by the Canadian price factor.  
 ▶ See page 1 for details.

# ZILO Seat Cover



Standard Includes	Required to Specify
<ul style="list-style-type: none"> <li>• Seat cover: fabric price group 1</li> </ul>	1 Style number 2 Fabric color number for seat cover 3 Options, if selected (see below) ▶ See <i>Surface Materials</i> , page 508.

	Options	U.S. Price	Required to Specify
<b>Surface Materials</b>	<b>Seat cover</b> <ul style="list-style-type: none"> <li>• Vinyl price group 2</li> <li>• Fabric price group 2</li> <li>• Fabric price group 3</li> <li>• Polyurethane</li> </ul>	+\$21 +\$21 +\$42 +\$74	Specify vinyl color number. Specify fabric color number. Specify fabric color number. Specify polyurethane color number.

Specification Information	
• Style Number	• U.S. Base Price
ZILOSEATCOVER	\$69
.	.
.	.


**For Canadian Pricing**  
 Multiply U.S. Price by the Canadian price factor.  
 ▶ See page 1 for details.

---

# PERSONALITY PLUS

<b>Understanding</b>	<b>438</b>
<b>Specifying</b>	<b>439</b>

# Personality Plus Features

- Chair or Stool
- Frame available in Seagull or Black
- Base available in Polished Aluminum, Seagull, and Black\*
- Weight Activated Mechanism with 40% Boost Setting
- 4-Way, 1-Way Adjustable Arms or Armless
- Adjustable Lumbar Support
- Seat Depth Adjustment (seat slider)
- Optional Headrest
- Fully Assembled option

\*Tip: Stool base is only available in polished aluminum.



# Personality Plus Specifications

Weight Capacity	275 lbs
Net Weight	37 lbs
Height Range	37.75" - 42.375"
Back Dimensions	16.38"W x 22.83"H
Seat Dimensions	17.72"D x 18.03"W
Seat Height Range	16.30" - 20.87"
Arms Span (outside edges)	18.74"
Body Frame Material	Nylon
Base Materials	Polished Aluminum and Nylon
Base Width	Nylon: 27" / Polished Aluminum: 27.5"
Cushion Seats	Polyurethane fill
Seat Covers	Drawstring upholstery
Mesh Back Material	34% Polyamide, 66% Polyester
Castors	Hard or Soft with roll control (Black)
Certifications	ANSI/BIFMA X5.1-2017 TB117-2013 Indoor Advantage Gold™

# PERSONALITY PLUS Task Chair

PERSONALITY PLUS  
Task Chair



Tip: Illustration above shows a fully assembled chair which is not included in the base price.

Tip: Illustration above shows chair with arms, which is not included in the base price.

Tip: Casters available in black only.

Tip: Soft caster is roll-control.

Tip: Headrest finish matches frame finish.

Tip: Arm available in black only.

Tip: Plastic base finish matches frame finish. Polished aluminum base available on black or seagull frame.

Standard Includes	Required to Specify
<ul style="list-style-type: none"> <li>• Seat: fabric</li> <li>• 4½" pneumatic seat-height adjustment (16¾"-20¼")</li> <li>• Plastic frame: black</li> <li>• Base: black plastic</li> <li>• 2¾" seat depth adjustment (seat slider)</li> <li>• Mesh back: fabric</li> <li>• Fabric price group 1 on seat</li> <li>• Armless</li> <li>• Adjustable lumbar support</li> <li>• Weight activated mechanism</li> <li>• 2½" diameter, hard-composition, dual-wheel black casters</li> </ul>	<ol style="list-style-type: none"> <li>1 Style number</li> <li>2 Fabric color number for seat</li> <li>3 Fabric color number for back</li> <li>4 Options, if selected (see below)</li> </ol> <p>▶ See <i>Surface Materials</i>, page 508.</p>

Options	U.S. Price	Required to Specify
<b>Surface Materials</b>	<b>Seat cover</b> <ul style="list-style-type: none"> <li>• Fabric price group 1 No cost</li> <li>• Fabric price group 2 +\$ 20</li> <li>• Vinyl price group 2 +\$ 20</li> <li>• Fabric price group 3 +\$ 41</li> <li>• Polyurethane +\$ 74</li> </ul>	Specify fabric color number. Specify fabric color number. Specify vinyl color number. Specify fabric color number. Specify polyurethane color number.
	<b>Back frame</b> <ul style="list-style-type: none"> <li>• Black frame No cost</li> <li>• Seagull frame +\$ 25</li> </ul>	Specify with <i>black frame</i> . Specify with <i>seagull frame</i> .
	<b>Base</b> <ul style="list-style-type: none"> <li>• Black base No cost</li> <li>• Seagull base No cost</li> <li>• Polished aluminum base +\$ 33</li> </ul>	Specify with <i>black base</i> . Specify with <i>seagull base</i> . Specify with <i>polished aluminum base</i> .
<b>Casters</b>	<ul style="list-style-type: none"> <li>• Hard casters No cost</li> <li>• Soft casters +\$ 38</li> </ul>	Specify with <i>hard casters</i> . Specify with <i>soft casters</i> .
<b>Headrest</b>	<ul style="list-style-type: none"> <li>• No headrest No cost</li> <li>• With headrest +\$ 79</li> </ul>	Specify with <i>no headrest</i> . Specify with <i>headrest</i> .
<b>Arm</b>	<ul style="list-style-type: none"> <li>• Armless No cost</li> <li>• Height-adjustable arm (1-D) +\$ 53</li> <li>• 4-D arm +\$106</li> </ul>	Specify with <i>no arms</i> . Specify with <i>height-adjustable arms</i> . Specify with <i>white 4-D arms</i> .
<b>Packaging</b>	<ul style="list-style-type: none"> <li>• Knocked down No cost</li> <li>• Fully assembled +\$ 98</li> </ul>	Specify <i>knocked down</i> . Specify <i>fully assembled</i> .

Specification Information	
Style Number	U.S. Base Price
PPCHAIR	\$686

PERSONALITY PLUS



**For Canadian Pricing**  
Multiply U.S. Price by the Canadian price factor.  
▶ See page 1 for details.

# PERSONALITY PLUS Stool



Tip: Illustration above shows a fully assembled chair which is not included in the base price.

Tip: Personality Plus stool available with a polished aluminum base only.

Tip: Illustration above shows chair with arms, which is not included in the base price.

Tip: Casters available in black only.

Tip: Soft caster is roll-control.

Tip: Headrest finish matches frame finish.

Tip: Arms available in black only.

Standard Includes	Required to Specify
<ul style="list-style-type: none"> <li>• 10¼" pneumatic seat-height adjustment (22¾"–32¾")</li> <li>• Plastic frame: black</li> <li>• Base: polished aluminum</li> <li>• 2¾" seat depth adjustment (seat slider)</li> <li>• Mesh back: fabric</li> <li>• Fabric price group 1 on seat</li> <li>• Armless</li> <li>• Adjustable lumbar support</li> <li>• Weight activated mechanism</li> <li>• Column and adjustable footring: black</li> <li>• 2½" diameter, hard-composition, dual-wheel black casters</li> </ul>	<ol style="list-style-type: none"> <li>1 Style number</li> <li>2 Fabric color number for seat</li> <li>3 Fabric color number for back</li> <li>4 Options, if selected (see below)</li> </ol> <p>▶ See <i>Surface Materials</i>, page 508.</p>

Options	U.S. Price	Required to Specify
<b>Surface Materials</b> <b>Seat cover</b> <ul style="list-style-type: none"> <li>• Fabric price group 1</li> <li>• Fabric price group 2</li> <li>• Vinyl price group 2</li> <li>• Fabric price group 3</li> <li>• Polyurethane</li> </ul>	No cost +\$ 20 +\$ 20 +\$ 41 +\$ 74	Specify fabric color number. Specify fabric color number. Specify vinyl color number. Specify fabric color number. Specify polyurethane color number.
<b>Back frame</b> <ul style="list-style-type: none"> <li>• Black frame</li> <li>• Seagull frame</li> </ul>	No cost +\$ 25	Specify with black frame. Specify with seagull frame.
<b>Casters</b> <ul style="list-style-type: none"> <li>• Hard casters</li> <li>• Soft casters</li> </ul>	No cost +\$ 38	Specify with hard casters. Specify with soft casters.
<b>Headrest</b> <ul style="list-style-type: none"> <li>• No headrest</li> <li>• With headrest</li> </ul>	No cost +\$ 79	Specify with no headrest. Specify with headrest.
<b>Arm</b> <ul style="list-style-type: none"> <li>• Armless</li> <li>• Height-adjustable arm (1-D)</li> <li>• 4-D arm</li> </ul>	No cost +\$ 53 +\$106	Specify with no arms. Specify with height-adjustable arms. Specify with white 4-D arms.
<b>Packaging</b> <ul style="list-style-type: none"> <li>• Knocked down</li> <li>• Fully Assembled</li> </ul>	No cost +\$ 98	Specify knocked down. Specify fully assembled.

Specification Information	
Style Number	U.S. Base Price
PPSTOOL	\$983



**For Canadian Pricing**  
 Multiply U.S. Price by the Canadian price factor.  
 ▶ See page 1 for details.



Standard Includes	Required to Specify
<ul style="list-style-type: none"> <li>• Headrest: black or seagull</li> <li>• 1½" adjustment range</li> </ul>	<ul style="list-style-type: none"> <li>1 Style number</li> <li>2 Plastic color number for headrest</li> </ul>

Specification Information	
Style Number	U.S. Price
PPHEADREST	\$79



 **For Canadian Pricing**  
 Multiply U.S. Price by the Canadian price factor.  
 ▶ See page 1 for details.



---

# BODI



**Understanding**

**444**



**Specifying**

**445**

# Bodi Features

- Available in Black and White frames
- Syncro with Tension Adjuster and Locking Mechanism
- Adjustable Armrest with PU Pad
- Adjustable Lumbar Support
- Seat Depth Adjustment (seat slider)
- Removable/Washable Seat Covers



# Bodi Specifications

Weight Capacity	275 lbs
Net Weight	33 lbs
Height Range	37.25" - 42.75"h
Back Dimensions	19"w x 23.75"h
Seat Dimensions	19"w x 20"d
Seat Height Range	17.5" - 23"
Arms Span (outside edges)	24.25"
Base Width	27"
Base / Body Frame Material	Nylon
Cushion Seats	Polyurethane fill
Seat Covers	Removable, with zip closure
Castors	Soft* PU (Black or White/Grey)
Mesh Back Material	Polyester/Polyelastomer/Nylon
Certifications	ANSI/BIFMA X5.1-2017 TB117-2013 Indoor Advantage Gold™



Tip: Illustration above shows a fully assembled chair which is not included in the base price.

Tip: Illustration above shows chair with arms, which is not included in the base price.

Standard Includes	Required to Specify
<ul style="list-style-type: none"> <li>• 5 1/2" pneumatic seat-height adjustment (17 1/2"—23")</li> <li>• Frame: black plastic</li> <li>• Base: plastic</li> <li>• Seat depth adjustment (seat slider)</li> <li>• Fabric price group 1 on seat</li> <li>• Removable seat covers with zip closure</li> <li>• Armless</li> <li>• Mesh back: fabric</li> <li>• Multi-position back lock</li> <li>• Adjustable lumbar support</li> <li>• Synchronized mechanism with tension adjustment and locking mechanism</li> <li>• 2 1/2" diameter, soft-composition, dual-wheel black casters</li> </ul>	<ol style="list-style-type: none"> <li>1 Style number</li> <li>2 Fabric color number for seat</li> <li>3 Fabric color number for back</li> <li>4 Options, if selected (see below)</li> </ol> <p>▶ See <i>Surface Materials</i>, page 508.</p>

	Options	U.S. Price	Required to Specify
<b>Surface Materials</b>	<b>Seat cover</b>		
	<ul style="list-style-type: none"> <li>• Fabric price group 1</li> <li>• Fabric price group 2</li> <li>• Vinyl price group 2</li> <li>• Fabric price group 3</li> <li>• Polyurethane</li> </ul>	No cost +\$21 +\$21 +\$42 +\$75	Specify fabric color number. Specify fabric color number. Specify vinyl color number. Specify fabric color number. Specify polyurethane color number.
	<b>Back frame</b>		
	<ul style="list-style-type: none"> <li>• Black frame</li> <li>• White frame</li> </ul>	No cost +\$69	Specify <i>with black frame</i> . Specify <i>with white frame</i> .
<b>Arm</b>	<ul style="list-style-type: none"> <li>• Armless</li> <li>• Height adjustable arm (1-D)</li> </ul>	No cost +\$90	Specify <i>with armless</i> . Specify <i>with height adjustable arm (1-D)</i> .
<b>Packaging</b>	<ul style="list-style-type: none"> <li>• Knocked down</li> <li>• Fully assembled</li> </ul>	No cost +\$98	Specify <i>with knocked down</i> . Specify <i>with fully assembled</i> .

Specification Information	
• Style Number	• U.S. Base Price
<b>BODICHAIR</b>	\$595
.	.

**For Canadian Pricing**  
 Multiply U.S. Price by the Canadian price factor.  
 ▶ See page 1 for details.

# BODI Seat Cover



Standard Includes	Required to Specify
<ul style="list-style-type: none"> <li>• Seat cover: fabric price group 1</li> </ul>	1 Style number 2 Fabric color number for seat cover 3 Options, if selected (see below) ▶ See <i>Surface Materials</i> , page 508.

	Options	U.S. Price	Required to Specify
<b>Surface Materials</b>	<b>Seat cover</b> <ul style="list-style-type: none"> <li>• Vinyl price group 2</li> <li>• Fabric price group 2</li> <li>• Fabric price group 3</li> <li>• Polyurethane</li> </ul>	+\$22 +\$22 +\$43 +\$75	Specify vinyl color number. Specify fabric color number. Specify fabric color number. Specify polyurethane color number.

Specification Information	
• Style Number	• U.S. Base Price
BODISEATCOVER	\$66



**For Canadian Pricing**  
 Multiply U.S. Price by the Canadian price factor.  
 ▶ See page 1 for details.

---

# FL-X

<b>Understanding</b>	<b>448</b>
<b>Specifying</b>	<b>449</b>

## FL-X Features

---

Weight activated back tilt mechanism

---

Height adjustable

---

Shell or Mesh back

---

Smooth coated armrest pads

---

Seat colors in 11 fabrics and 3 vinyl

---

Available in Black, White and Light Grey/White

---

Mesh back includes additional lumbar support piece

---

Optional fabric back cover for Shell back

---



## FL-X Specifications

---

Weight Capacity	275 lbs
-----------------	---------

---

Net Weight	36 lbs
------------	--------

---

Chair Total Height	37"—41.5"
--------------------	-----------

---

Height Adjustable Range	4.7"
-------------------------	------

---

Base Width	27"
------------	-----

---

Back Dimensions	16.5"w x 22"h
-----------------	---------------

---

Seat Dimensions	18"w x 19.5"d
-----------------	---------------

---

Seat Height Range	16"—21"
-------------------	---------

---

Arms Span (outside edges)	24.5"
---------------------------	-------

---

Body Frame Material	Nylon
---------------------	-------

---

Base Material	Nylon
---------------	-------

---

Cushion Seat	Polyurethane foam and fabric
--------------	------------------------------

---

Castors	Nylon, soft* (Black & White/Grey)
---------	-----------------------------------

---



Tip: Illustration above shows a fully assembled chair which is not included in the base price.

Tip: Base finish matches frame finish.

Tip: White frame, white back not available with mesh back.

Tip: Back finish applicable to fabric back cover only.

Standard Includes	Required to Specify
<ul style="list-style-type: none"> <li>4" pneumatic seat-height adjustment (16"-21")</li> <li>Frame: black plastic</li> <li>Plastic perforated back shell</li> <li>Seat depth adjustment (seat slider)</li> <li>Fabric price group 1 on seat</li> <li>Fixed arms</li> <li>Adjustable lumbar support</li> <li>2 1/2" diameter, soft-composition, dual-wheel black casters</li> </ul>	<ol style="list-style-type: none"> <li>Style number</li> <li>Fabric color number for seat</li> <li>Fabric color number for back</li> <li>Options, if selected (see below)</li> </ol> <p>▶ See <i>Surface Materials</i>, page 508.</p>

Options	U.S. Price	Required to Specify
<b>Surface Materials</b> <b>Frame</b> <ul style="list-style-type: none"> <li>Black frame, black back</li> <li>White frame, light grey back</li> <li>White frame, white back</li> </ul>	<ul style="list-style-type: none"> <li>No cost</li> <li>+\$ 34</li> <li>+\$ 68</li> </ul>	<ul style="list-style-type: none"> <li>Specify with <i>black frame, black back</i>.</li> <li>Specify with <i>white frame, light grey back</i>.</li> <li>Specify with <i>white frame, white back</i>.</li> </ul>
<b>Back type</b> <ul style="list-style-type: none"> <li>Shell back</li> <li>Mesh back</li> <li>Fabric back cover</li> </ul>	<ul style="list-style-type: none"> <li>No cost</li> <li>+\$ 34</li> <li>+\$ 78</li> </ul>	<ul style="list-style-type: none"> <li>Specify with <i>shell back</i>.</li> <li>Specify with <i>mesh back</i>.</li> <li>Specify with <i>fabric back cover</i>.</li> </ul>
<b>Back</b> <ul style="list-style-type: none"> <li>Fabric price group 1</li> <li>Fabric price group 2</li> </ul>	<ul style="list-style-type: none"> <li>No cost</li> <li>+\$ 33</li> </ul>	<ul style="list-style-type: none"> <li>Specify fabric color number.</li> <li>Specify fabric color number.</li> </ul>
<b>Seat cover</b> <ul style="list-style-type: none"> <li>Fabric price group 1</li> <li>Fabric price group 2</li> <li>Vinyl price group 4</li> </ul>	<ul style="list-style-type: none"> <li>No cost</li> <li>+\$ 34</li> <li>+\$ 87</li> </ul>	<ul style="list-style-type: none"> <li>Specify fabric color number.</li> <li>Specify fabric color number.</li> <li>Specify vinyl color number.</li> </ul>
<b>Cylinder</b> <ul style="list-style-type: none"> <li>Standard</li> <li>Drafting ring with extended height</li> </ul>	<ul style="list-style-type: none"> <li>No cost</li> <li>+\$215</li> </ul>	<ul style="list-style-type: none"> <li>Specify with <i>standard cylinder</i>.</li> <li>Specify with <i>drafting ring with extended height</i>.</li> </ul>
<b>Packaging</b> <ul style="list-style-type: none"> <li>Knocked down</li> <li>Fully assembled</li> </ul>	<ul style="list-style-type: none"> <li>No cost</li> <li>+\$ 98</li> </ul>	<ul style="list-style-type: none"> <li>Specify with <i>knocked down</i>.</li> <li>Specify with <i>fully assembled</i>.</li> </ul>

Specification Information	
Style Number	U.S. Base Price
FLXXCHAIR	\$913

**For Canadian Pricing**  
 Multiply U.S. Price by the Canadian price factor.  
 ▶ See page 1 for details.

# Seat Covers

## FL-X Seat Cover and Assembly



Tip: Contains the entire seat assembly: cushion, fabric, and inner seat pan.

Standard Includes	Required to Specify
-------------------	---------------------

- Seat cover

- 1 Style number
- 2 Fabric color number for seat cover
- ▶ See *Surface Materials*, page 508.

Specification Information		
Style Number	Price Group	U.S. Price

Style Number	Price Group	U.S. Price
<b>FLXXSEATCOVER</b>	Fabric Price Group 1	\$143
	Fabric Price Group 2	\$176
	Vinyl Price Group 4	\$229
:	:	:

## FL-X Back Cover



Standard Includes	Required to Specify
-------------------	---------------------

- Back cover

- 1 Style number
- 2 Fabric color number for seat cover
- ▶ See *Surface Materials*, page 508.

Specification Information		
Style Number	Price Group	U.S. Price

Style Number	Price Group	U.S. Price
<b>FLXXBACKCOVER</b>	Fabric Price Group 1	\$ 78
	Fabric Price Group 2	\$111
:	:	:



**For Canadian Pricing**  
 Multiply U.S. Price by the Canadian price factor.  
 ▶ See page 1 for details.

---

# TIZU

<b>Understanding</b>	<b>452</b>
<b>Specifying</b>	<b>454</b>



## Tizu Work Features

---

Height adjustable

---

Mesh back with lumbar support or plastic back

---

Fixed Loop Arms or Armless with torsion tilt

---

Removable seat covers in Buzz, Era, Connect and Brisa Collections

---

Available in Black with Black base and White with Chrome base

---



## Tizu Work Specifications

Weight Capacity	275 lbs
Net Weight	27 lbs.
Chair Total Height	37" - 41"
Height Adjustable Range	4"
Base Width	26.5"
Back Width (top)	17"
Seat Dimensions	17.75"w x 18.5"d
Seat Height Range	18" - 22"
Arms Span (outside edges)	23.5"
Body Frame Material	Nylon
Base Material	Nylon (Black) / Aluminum (Grey)
Mesh Back Material	Polyester/Polyelastomer/Nylon
Cushion Seat	Polyurethane foam / fabric
Castors	Soft* PU (Black or White/Grey)
Certifications	ANSI/BIFMA X5.1-2017 TB117-2013 Indoor Advantage Gold™

# Tizu Features

- \_\_\_\_\_  
Nesting
- \_\_\_\_\_  
Available in Black and White
- \_\_\_\_\_  
Mesh back with lumbar support or plastic back
- \_\_\_\_\_  
Torsion Tension with Fixed Loop Arms or Armless
- \_\_\_\_\_  
Removable seat covers in Buzz, Era, Connect and Brisa Collections
- \_\_\_\_\_  
Glides Available



# Tizu Specifications

Weight Capacity	275 lbs
Net Weight	22 lbs
Seat Dimension	17.75" w x 18.5" d
Back Dimensions	19" w x 20" h
Arms Span (outside edges)	23.5"
Legs Dimension	19.25" w x 20.5" d
Seat Height from Floor	19"
Back Height from Floor	37.5"
Nesting Depth Increase	11" (per chair – average of 10 nested chairs)
Body Frame Material	Plastic
Leg Frame Materials	Steel
Cushion Seats	Polyurethane fill
Castors	Soft* PU (Black or White/Grey)
Seat Covers	Removable with zip closure
Mesh Back Material	Polyester/Polyelastomer/Nylon
Certifications	ANSI/BIFMA X5.1-2017 TB117-2013 Indoor Advantage Gold™

# TIZU Task Chair



*Tip: Black frame only available with black base and soft, black casters.*

*Tip: White frame only available with polished aluminum base and soft, 2-tone grey casters.*

*Tip: Arm upcharge only applicable to mesh back type.*

*Tip: Armless option not available with plastic back.*

*Tip: Base price does not include the required back upcharges. Please refer to SmartTools or the Electronic Catalog for accurate pricing.*

Standard Includes	Required to Specify
<ul style="list-style-type: none"> <li>4" pneumatic seat-height adjustment (18"–22")</li> <li>Frame: black plastic</li> <li>Base: black plastic</li> <li>Fabric price group 1 on seat</li> <li>Removable seat covers with zip closure</li> <li>Adjustable lumbar support</li> <li>Armless</li> <li>2½" diameter, soft-composition, dual-wheel black casters</li> </ul>	<ol style="list-style-type: none"> <li>Style number</li> <li>Fabric color number for seat</li> <li>Fabric color number for back</li> <li>Options, if selected (see below)</li> </ol> <p>▶ See <i>Surface Materials</i>, page 508.</p>

Surface Materials	Options	U.S. Price	Required to Specify
	<b>Back frame</b>		
	• Black frame	No cost	Specify <i>with black frame</i> .
	• White frame	+\$ 50	Specify <i>with white frame</i> .
	<b>Back</b>		
	• Mesh back		
	– Black frame	+\$193	Specify <i>with mesh back with black frame</i> .
	– White frame	+\$207	Specify <i>with mesh back with white frame</i> .
	• Plastic back		
	– Black frame	+\$214	Specify <i>with plastic back with black frame</i> .
	– White frame	+\$235	Specify <i>with plastic back with white frame</i> .
	<b>Seat cover</b>		
	• Fabric price group 1	No cost	Specify fabric color number.
	• Fabric price group 2	+\$ 21	Specify fabric color number.
	• Vinyl	+\$ 21	Specify vinyl color number.
	• Fabric price group 3	+\$ 42	Specify fabric color number.
	• Polyurethane	+\$ 75	Specify polyurethane color number.
	<b>Arm</b>		
	• Armless		
	– Black	No cost	Specify <i>with armless black</i> .
	– White	+\$ 5	Specify <i>with armless white</i> .
• Fixed loop			
– Black	+\$ 47	Specify <i>with fixed loop black</i> .	
– White	+\$ 56	Specify <i>with fixed loop white</i> .	
	<b>Base</b>		
	• Black base	No cost	Specify <i>with black base</i> .
• Polished aluminum base	No cost	Specify <i>with polished aluminum base</i> .	
<b>Casters</b>	• Soft, 2-tone grey	No cost	Specify <i>with soft, 2-tone grey</i> .
	• Soft, black	No cost	Specify <i>with soft, black</i> .
<b>Packaging</b>	• Knocked down	No cost	Specify <i>with knocked down</i> .
	• Fully assembled	+\$ 98	Specify <i>with fully assembled</i> .

## Specification Information

Style Number	U.S. Base Price
<b>TIZUWORK</b>	\$616

**For Canadian Pricing**  
 Multiply U.S. Price by the Canadian price factor.  
 ▶ See page 1 for details.



*Tip: Black frame only available with chrome base and soft, black casters or glides.*

*Tip: White frame only available with white or platinum base and soft, 2-tone grey casters or glides.*

*Tip: Arm upcharge only applicable to mesh back type.*

*Tip: Armless option not available with plastic back.*

*Tip: Base price does not include the required back upcharges. Please refer to SmartTools or the Electronic Catalog for accurate pricing.*

Standard Includes		Required to Specify	
<ul style="list-style-type: none"> <li>4-prong nesting base</li> <li>Frame: black plastic</li> <li>Base: chrome or platinum</li> <li>Fabric price group 1 on seat</li> <li>Removable seat covers with zip closure</li> <li>Fixed lumbar support</li> <li>Armless</li> <li>2 1/2" diameter, soft-composition, dual-wheel black casters</li> </ul>		<ol style="list-style-type: none"> <li>Style number</li> <li>Fabric color number for seat</li> <li>Fabric color number for back</li> <li>Options, if selected (see below)</li> </ol> <p>▶ See <i>Surface Materials</i>, page 508.</p>	

	Options	U.S. Price	Required to Specify
<b>Surface Materials</b>	<b>Back frame</b>		
	• Black frame	No cost	Specify with <i>black frame</i> .
	• White frame	No cost	Specify with <i>white frame</i> .
	<b>Back</b>		
	• Mesh back		
	– Black frame	+\$193	Specify with <i>mesh back with black frame</i> .
	– White frame	+\$207	Specify with <i>mesh back with white frame</i> .
	• Plastic back		
	– Black frame	+\$214	Specify with <i>plastic back with black frame</i> .
	– White frame	+\$235	Specify with <i>plastic back with white frame</i> .
	<b>Seat cover</b>		
	• Fabric price group 1	No cost	Specify fabric color number.
• Fabric price group 2	+\$ 21	Specify fabric color number.	
• Vinyl	+\$ 21	Specify vinyl color number.	
• Fabric price group 3	+\$ 42	Specify fabric color number.	
• Polyurethane	+\$ 75	Specify polyurethane color number.	
<b>Arm</b>			
• Armless			
– Black	No cost	Specify with <i>armless black</i> .	
– White	+\$ 5	Specify with <i>armless white</i> .	
• Fixed loop			
– Black	+\$ 47	Specify with <i>fixed loop black</i> .	
– White	+\$ 56	Specify with <i>fixed loop white</i> .	
<b>Base</b>			
• Chrome base	No cost	Specify with <i>chrome base</i> .	
• Platinum base	No cost	Specify with <i>platinum base</i> .	
• White base	+\$ 16	Specify with <i>white base</i> .	
<b>Casters or Glides</b>			
• Soft, 2-tone grey	No cost	Specify with <i>soft, 2-tone grey</i> .	
• Soft, black	No cost	Specify with <i>soft, black</i> .	
• Glides, black	+\$ 64	Specify with <i>glides, black</i> .	
<b>Packaging</b>			
• Knocked down	No cost	Specify with <i>knocked down</i> .	
• Fully assembled	+\$ 98	Specify with <i>fully assembled</i> .	

Specification Information	
Style Number	U.S. Base Price
TIZUNEST	\$454

 **For Canadian Pricing**  
 Multiply U.S. Price by the Canadian price factor.  
 ▶ See page 1 for details.

# Accessories

## TIZU Seat Cover



Standard Includes		Required to Specify	
<ul style="list-style-type: none"> <li>• Seat cover: fabric price group 1</li> </ul>		1 Style number 2 Fabric color number for seat cover 3 Options, if selected (see below) ▶ See <i>Surface Materials</i> , page 508.	
Surface Materials	Options	U.S. Price	Required to Specify
	<ul style="list-style-type: none"> <li>• Fabric price group 2</li> <li>• Vinyl</li> <li>• Fabric price group 3</li> <li>• Polyurethane</li> </ul>	+\$21 +\$21 +\$42 +\$75	Specify fabric color number. Specify vinyl color number. Specify fabric color number. Specify polyurethane color number.
Specification Information			
• Style Number	• U.S. Base Price		
.....	.....		
<b>TIZUSEATCOVER</b>	\$68		
.....	.....		

## TIZU Glides



Standard Includes		Required to Specify	
<ul style="list-style-type: none"> <li>• Set of four glides: black</li> </ul>		Style number	
Specification Information			
• Style Number	• U.S. Price		
.....	.....		
<b>TIZU-GLD</b>	\$64		
.....	.....		

 **For Canadian Pricing**  
 Multiply U.S. Price by the Canadian price factor.  
 ▶ See page 1 for details.

---

# BRIN



**Understanding**

**458**



**Specifying**

**459**

BRIN

## Brin Features

---

4-Leg and Wire Sled base options

---

Black frame with Pearl Grey or Black shell

---

Stacks 4-high on floor

---

One-piece molded shell with subtle perforations

---

Sold in sets of 4

---

Ships fully assembled

---



## Brin Specifications

Weight Capacity	300 lbs
Net Weight	4-Leg: 13.4 lbs / Sled: 15 lbs
Seat Dimension	18.4" w x 20" d
Back Dimensions	18.4" w x 14" h
Legs Dimensions	4-Leg: 21.25" w x 20.83" d / Sled: 21.5" w x 20.25" d
Seat Height from Floor	18"
Back Height from Floor	32.5"
Stacking Density	4 high on floor
Body Material	Fiberglass reinforced polypropylene
Leg Frame Materials	Tubular steel
Glides	Durable black polyethylene
Certifications	ANSI/BIFMA X5.1 Indoor Advantage Gold™

## Brin Stacking 4-Leg Chairs



Tip: Brin chairs can stack four high on floor.

Tip: Frame and underseat available in black only.

Standard Includes	Required to Specify
-------------------	---------------------

- Four fully assembled chairs
- Frame: 7207 Black paint
- Seat shell: plastic
- Glides: black plastic

- 1 Style number
- 2 Plastic color number for shell:
  - 6205 Black
  - 6139 Pearl Grey

Specification Information	
Style Number	U.S. Price

Style Number	U.S. Price
<b>BRNL4PK</b>	\$1380

BRIN

## Brin Stacking Wire Base Chairs



Tip: Brin chairs can stack four high on floor.

Tip: Frame and underseat available in black only.

Standard Includes	Required to Specify
-------------------	---------------------

- Four fully assembled chairs
- Frame: 7207 Black paint
- Seat shell: plastic
- Glides: black plastic

- 1 Style number
- 2 Plastic color number for shell:
  - 6205 Black
  - 6139 Pearl Grey

Specification Information	
Style Number	U.S. Price

Style Number	U.S. Price
<b>BRNW4PK</b>	\$1380



**For Canadian Pricing**  
 Multiply U.S. Price by the Canadian price factor.  
 ▶ See page 1 for details.



---

# West Elm Seating

---

<b>Statement of Line</b>	<b>462</b>
--------------------------	------------

<b>Brighton Lounge Seating</b>	
Understanding	<b>466</b>
Specifying	<b>483</b>
<b>Mesa Lounge Seating</b>	
Understanding	<b>470</b>
Specifying	<b>492</b>
<b>Nimbus</b>	
Specifying	<b>495</b>
<b>Sterling</b>	
Understanding	<b>474</b>
Specifying	<b>496</b>
<b>Lucas</b>	
Understanding	<b>478</b>
Specifying	<b>499</b>
<b>Slope</b>	
Understanding	<b>480</b>
Specifying	<b>500</b>

# Statement of Line

## Seating

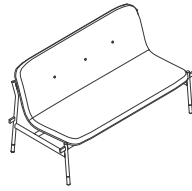
### Brighton

#### Lounge Seating



**Brighton One-Seat Lounge**

Understanding  
▶ Page 466  
Specifying  
▶ Page 483



**Brighton Two-Seat Lounge**

Understanding  
▶ Page 466  
Specifying  
▶ Page 484



**Brighton Ottoman**

Understanding  
▶ Page 466  
Specifying  
▶ Page 485

#### Occasional Tables



**Brighton 90° Ganging Table**

Understanding  
▶ Page 467  
Specifying  
▶ Page 486



**Brighton Straight Ganging Table**

Understanding  
▶ Page 467  
Specifying  
▶ Page 523



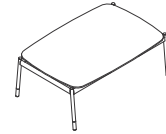
**Brighton End Table**

Understanding  
▶ Page 467  
Specifying  
▶ Page 488



**Brighton Square Table**

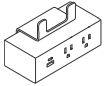
Understanding  
▶ Page 467  
Specifying  
▶ Page 489



**Brighton Rectangle Table**

Understanding  
▶ Page 467  
Specifying  
▶ Page 490

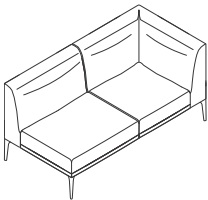
#### Accessories



**Brighton Module Power**

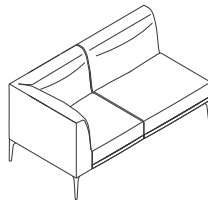
Specifying  
▶ Page 491

### Mesa



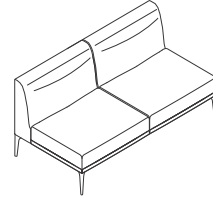
**Mesa Left-Hand Chaise Lounge**

Understanding  
▶ Page 470  
Specifying  
▶ Page 492



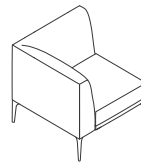
**Mesa Right-Hand Chaise Lounge**

Understanding  
▶ Page 470  
Specifying  
▶ Page 492



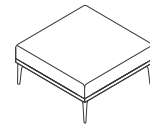
**Mesa Two-Seat Lounge**

Understanding  
▶ Page 470  
Specifying  
▶ Page 493



**Mesa Corner Lounge**

Understanding  
▶ Page 470  
Specifying  
▶ Page 493

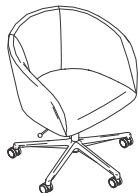


**Ottoman**

Understanding  
▶ Page 470  
Specifying  
▶ Page 494

## Seating, continued

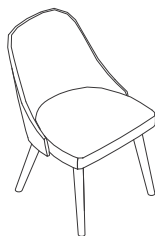
### Nimbus



#### Nimbus Conference Chair

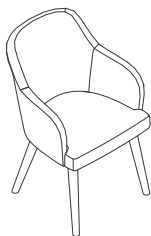
Specifying  
 ▶ Page 495

### Sterling



#### Sterling 4-Leg Armless Guest Chair

Understanding  
 ▶ Page 474  
 Specifying  
 ▶ Page 530



#### Sterling 4-Leg with Arms Guest Chair

Understanding  
 ▶ Page 474  
 Specifying  
 ▶ Page 496



#### Sterling Bar Height Armless Stool

Understanding  
 ▶ Page 474  
 Specifying  
 ▶ Page 497



#### Sterling 5-Star Armless Conference Chair

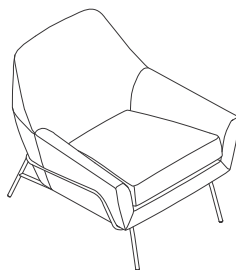
Understanding  
 ▶ Page 474  
 Specifying  
 ▶ Page 497



#### Sterling 5-Star with Arms Conference Chair

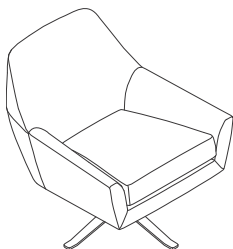
Understanding  
 ▶ Page 474  
 Specifying  
 ▶ Page 498

### Lucas



#### Lucas Wire Chair

Understanding  
 ▶ Page 478  
 Specifying  
 ▶ Page 499



#### Lucas Swivel Chair

Understanding  
 ▶ Page 478  
 Specifying  
 ▶ Page 499

**Seating, continued**

**Slope**



**Slope Guest Chair**  
Understanding  
▶ Page 480  
Specifying  
▶ Page 500



**Slope Lounge Chair**  
Understanding  
▶ Page 480  
Specifying  
▶ Page 500



**Slope Bar Height Stool**  
Understanding  
▶ Page 480  
Specifying  
▶ Page 501



**Slope Height-Adjustable Conference Chair**  
Understanding  
▶ Page 480  
Specifying  
▶ Page 501



**Slope Stacking Chair**  
Understanding  
▶ Page 480  
Specifying  
▶ Page 502

**Slope—Stocked**



**Slope Guest Chair—Stocked**  
Understanding  
▶ Page 480  
Specifying  
▶ Page 502



**Slope Lounge Chair—Stocked**  
Understanding  
▶ Page 480  
Specifying  
▶ Page 503



**Slope Bar Stool—Stocked**  
Understanding  
▶ Page 480  
Specifying  
▶ Page 503



**Slope Conference Chair—Stocked**  
Understanding  
▶ Page 480  
Specifying  
▶ Page 504



# Brighton Lounge Seating

**Inspired by the traditional wood frame joinery of mid-century design,** Brighton lounge seating offers an updated take with sleek metal construction. It's configurability allows Brighton to arrange into infinite formations, while freestanding lounge and table options create even more choice.

**Ganging tables** are available in laminate. Tables come with ganging brackets to attach between or on the end of lounge units.

**Frame caps** are offered in black paint.

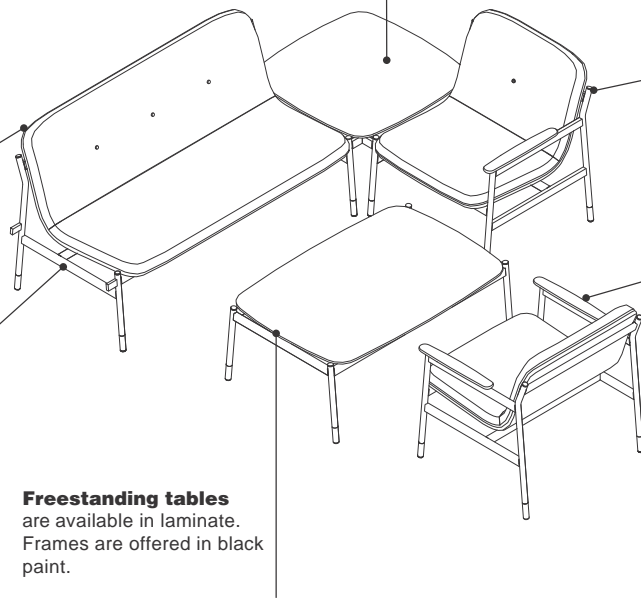
**Lounge seat and backs** are fully upholstered.

**Arms** are available on lounge units. Arm caps are black oak.

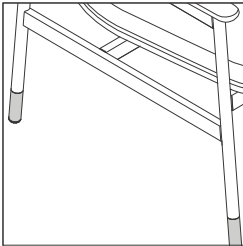
**Frames** are offered in black paint.

**Frame feet** are black paint.

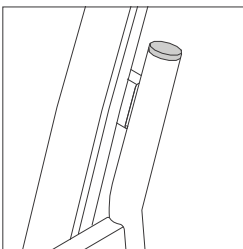
**Freestanding tables** are available in laminate. Frames are offered in black paint.



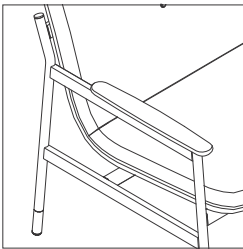
**Product Details**



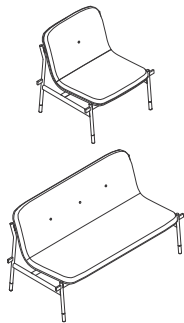
**Frame feet** are offered in black paint.



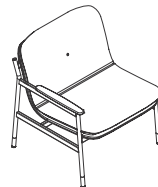
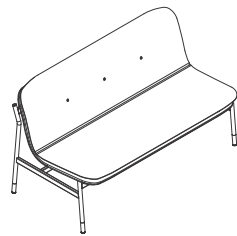
**Frame caps** are offered in black paint.



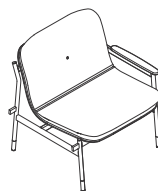
**Armcaps** are solid oak wood and are available on both one- and two-seat lounges in black oak.



**Button tufting** is standard on all lounges that are upholstered in fabric. One-seat lounges come standard with one button, two-seat lounges come with three buttons.



Arm Right



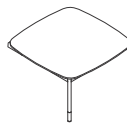
Arm Left

**One- and two-seat lounges** are available with and without arms and can be specified with ganging hardware or as freestanding.

**Lounges** must be specified with ganging hardware when used with end or ganging tables. Ganging hardware and arms cannot be specified on the same side of a lounge unit.



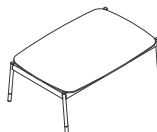
**Ottoman** is upholstered with a metal frame that is available in black paint.



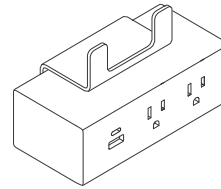
**Ganging tables** are available in two options: 90° and straight. Tables can be attached facing either direction and must be attached between lounge units.



**End table** is available in one size 28" square and can be added to either side of a lounge unit.



**Freestanding tables** are available in 28" square and 28"D x 42"W rectangle.



**Power module** has a 9' cord, two AC outlets, and one USB A+C 20W.

**Surface Materials**

**Upholstery**

- Billiard

**Table tops**

- High-Pressure Laminate

**Frames**

- 7207 Black

**Feet and caps**

- 7207 Black

**Arms**

- VP03 Black Oak

**Power**

- 6000 Black

**Dimensions**

▶ Page 468

# Dimensions

## Brighton Lounge Seating

Features	Overall Depth	Width	Height	Functional Seat Depth	Seat Width	Seat Height from Floor
<b>Brighton</b>						
<b>Lounge Seating</b>						
One-Seat Lounge	29 <sup>3</sup> / <sub>4</sub> "	29 <sup>7</sup> / <sub>8</sub> "	33 <sup>1</sup> / <sub>16</sub> "	19 <sup>7</sup> / <sub>16</sub> "	26 <sup>1</sup> / <sub>4</sub> "	17 <sup>7</sup> / <sub>16</sub> "
Two-Seat Lounge	29 <sup>3</sup> / <sub>4</sub> "	57 <sup>9</sup> / <sub>16</sub> "	33 <sup>1</sup> / <sub>16</sub> "	19 <sup>7</sup> / <sub>16</sub> "	54"	17 <sup>7</sup> / <sub>16</sub> "
Ottoman	16 <sup>3</sup> / <sub>32</sub> "	19 <sup>15</sup> / <sub>32</sub> "	16 <sup>23</sup> / <sub>32</sub> "	N.A.	N.A.	N.A.
90° Ganging Table	29"	29"	15 <sup>11</sup> / <sub>16</sub> "	N.A.	N.A.	N.A.
End Table	28 <sup>1</sup> / <sub>2</sub> "	28 <sup>1</sup> / <sub>4</sub> "	15 <sup>11</sup> / <sub>16</sub> "	N.A.	N.A.	N.A.
Square Table	28 <sup>1</sup> / <sub>2</sub> "	28 <sup>1</sup> / <sub>4</sub> "	15 <sup>11</sup> / <sub>16</sub> "	N.A.	N.A.	N.A.
Rectangle Table	28 <sup>1</sup> / <sub>2</sub> "	42"	15 <sup>11</sup> / <sub>16</sub> "	N.A.	N.A.	N.A.



# Mesa Lounge Seating

**Mesa lounge seating** adds style to any workspace with its modern form and tapered legs. Modular pieces can easily create common areas of any size.

**Connector brackets** are standard with all lounges and ottomans.

**Lounge units** can be connected together to create an L- or U-configuration. Two corners can be used together for a two-seat sofa.

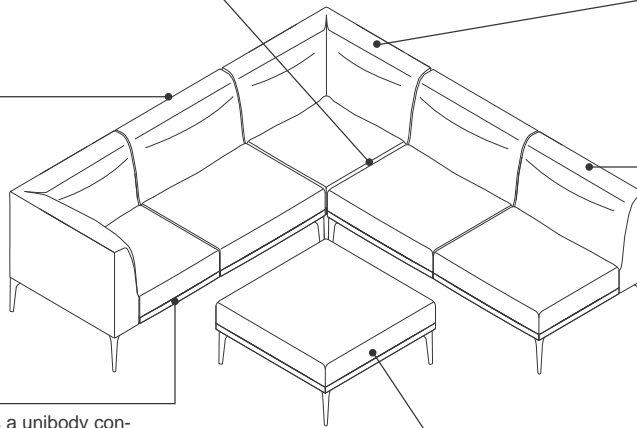
**Lounge units** are available in two-seat lounge, right- and left-hand chaise lounge, and corner lounge.

**Upholstered seat and back cushions** are attached.

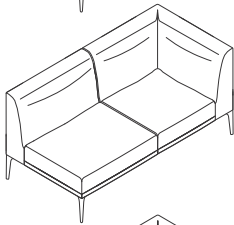
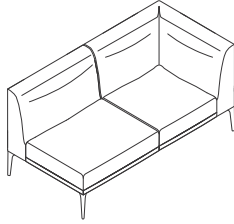
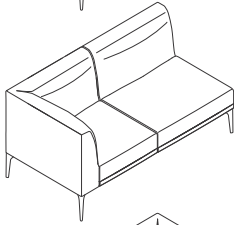
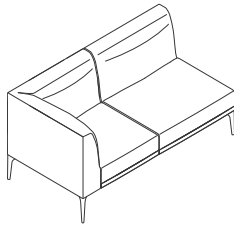
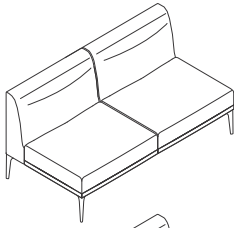
**Frame** is a unibody construction with finger jointed plywood.

**Tapered legs** are cast aluminum and coated in WE01 Antique Bronze.

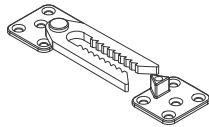
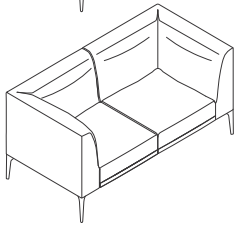
**Ottoman** is freestanding.



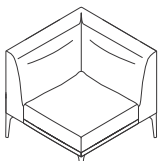
**Product Details**



**Chaise lounge** can be specified in a right- or left-hand configuration.  
*Tip: Handedness is determined while in the seated position.*



**Integrated ganging device** is included and keeps units aligned.



**Lounge seating** features five fully upholstered, complementary models: two-seater lounge, right-hand chaise lounge, left-hand chaise lounge, corner lounge, and ottoman. All models feature a four-leg, cast aluminum base with a powder coat painted finish.

**Surface Materials**

**Upholstery**

- Billiard

**Legs**

- WE01 Antique Bronze
- Tip: Contrasting fabric is not available on Mesa.*

**Dimensions**

▶ Page 472

# Dimensions

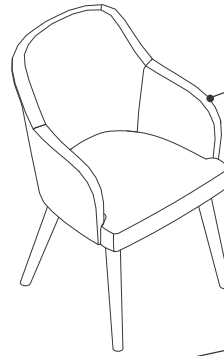
## Mesa Lounge Seating

• Features	• Overall Depth	Width	Height	• Functional Seat Depth	• Seat Width	• Seat Height from Floor
<b>Mesa</b>						
<b>Lounge Seating</b>						
Two-Seat	32 <sup>1</sup> / <sub>4</sub> "	64 <sup>1</sup> / <sub>4</sub> "	28 <sup>3</sup> / <sub>4</sub> "	22 <sup>3</sup> / <sub>4</sub> "	64 <sup>1</sup> / <sub>4</sub> "	17 <sup>3</sup> / <sub>4</sub> "
Chaise	32 <sup>1</sup> / <sub>4</sub> "	64 <sup>1</sup> / <sub>4</sub> "	28 <sup>3</sup> / <sub>4</sub> "	22 <sup>3</sup> / <sub>4</sub> "	55"	17 <sup>3</sup> / <sub>4</sub> "
Corner	32 <sup>1</sup> / <sub>4</sub> "	32 <sup>1</sup> / <sub>4</sub> "	28 <sup>3</sup> / <sub>4</sub> "	22 <sup>3</sup> / <sub>4</sub> "	22 <sup>3</sup> / <sub>4</sub> "	17 <sup>3</sup> / <sub>4</sub> "
Ottoman	32 <sup>1</sup> / <sub>4</sub> "	32 <sup>1</sup> / <sub>4</sub> "	17 <sup>3</sup> / <sub>4</sub> "	N.A.	N.A.	N.A.

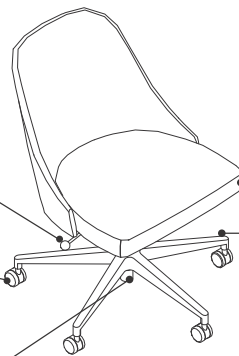


# Sterling Seating

**Sterling** is a family of seating inspired by classic mid-century design. The style and generous sit brings retro-inspired comfort to the office. Hardwood legs or a classic aluminum base and arm options make the Sterling collection relevant across the floor plan.



**Arms** are optional on guest chair and conference chair. Arms are always upholstered.

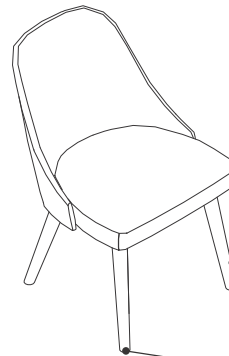


**Optional tilt mechanism** enhances user comfort. Available on the five-star base.

**Seat height** adjusts 5", from 16 $\frac{1}{2}$ "H to 21 $\frac{1}{2}$ "H, with a pneumatic adjustment mechanism.

**Casters** have hard, dual-wheels that roll smoothly on carpets.

**Five-star base** is aluminum and available polished or in black paint.

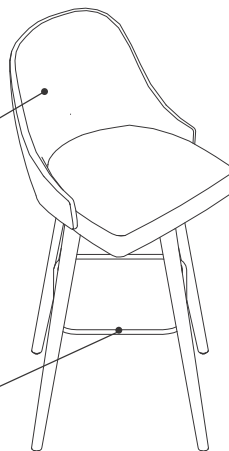


**Pneumatic cylinder** is always black.

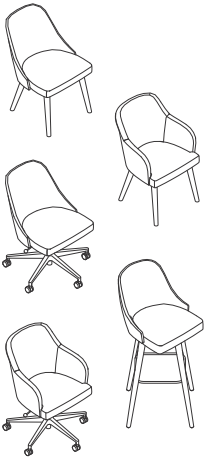
**Wood leg** is beech hardwood and available in VP03 Black Oak.

**Sterling stools** have a 360° swivel feature that comes standard and does not have auto-return feature.

**Glides** are polyethylene for superior durability on carpeted and hard floors.



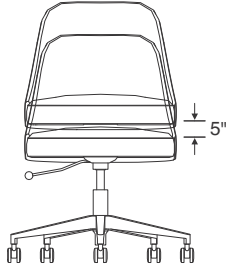
**Sterling stools** include footrest for added comfort. *Tip: The footrest is 8 $\frac{1}{2}$ " from the ground on the counter-height stool and 14 $\frac{1}{4}$ " on the bar-height stool.*

**Product Details**

**Five-star, and four-leg** chairs are available with and without arms.

**Optional tilt mechanism** is available on five-star chairs and has 10° rearward and 2° forward tilt range. The seat and back always remain in a fixed position relative to each other (i.e. no recline).

**360° adjustable height swivel mechanism** is standard on five-star base.

**Adjustment Features****Seat Adjustments**

**Seat height** adjusts pneumatically. To lower, pull lever up while seated. To raise, pull lever up and keep your weight off the chair.

**Surface Materials****Upholstery**

- Billiard

**Four-leg and stool base**

- VP03 Black Oak

**Five-star base**

- 7207 Black
- 8046 Polished Aluminum

**Casters and glides**

- 6205 Black

**All seating with standard upholstery fabrics**

complies with requirements of the State of California Technical Bulletin 117-2013. All standard seating is labeled to be in compliance with California 117-2013.

**Dimensions**

▶ Page 476

# Dimensions

## Sterling Seating

Features	Overall Depth	Width	Height	Functional Seat Depth	Seat Width	Seat Height from Floor	Back Width	Back Height from Seat	Arm Height from Floor
<b>West Elm Work Sterling</b>									
<b>Guest Chairs</b>									
	25 <sup>1</sup> / <sub>8</sub> "	26 <sup>3</sup> / <sub>4</sub> "	32 <sup>5</sup> / <sub>8</sub> "	18 <sup>5</sup> / <sub>8</sub> "	22"	18 <sup>1</sup> / <sub>2</sub> "	21"	15 <sup>1</sup> / <sub>2</sub> "	26 <sup>1</sup> / <sub>2</sub> "
<b>Guest Chairs—Armless</b>									
	24 <sup>1</sup> / <sub>2</sub> "	23 <sup>1</sup> / <sub>2</sub> "	32 <sup>5</sup> / <sub>8</sub> "	18 <sup>5</sup> / <sub>8</sub> "	22"	18 <sup>1</sup> / <sub>2</sub> "	21"	15 <sup>1</sup> / <sub>2</sub> "	N.A.
<b>Conference Chairs—Five-Star with Arms</b>									
	25 <sup>1</sup> / <sub>8</sub> "	26 <sup>3</sup> / <sub>4</sub> "	31 <sup>3</sup> / <sub>4</sub> "–36 <sup>3</sup> / <sub>4</sub> "	18 <sup>5</sup> / <sub>8</sub> "	22"	16 <sup>1</sup> / <sub>2</sub> "–21 <sup>1</sup> / <sub>2</sub> "	21"	15 <sup>1</sup> / <sub>2</sub> "	25 <sup>1</sup> / <sub>4</sub> "
<b>Conference Chairs—Five-Star Armless</b>									
	24 <sup>1</sup> / <sub>2</sub> "	23 <sup>1</sup> / <sub>2</sub> "	31 <sup>3</sup> / <sub>4</sub> "–36 <sup>3</sup> / <sub>4</sub> "	18 <sup>5</sup> / <sub>8</sub> "	22"	16 <sup>1</sup> / <sub>2</sub> "–21 <sup>1</sup> / <sub>2</sub> "	21"	15 <sup>1</sup> / <sub>2</sub> "	N.A.
<b>Bar Height Stool</b>									
	26 <sup>1</sup> / <sub>4</sub> "	26 <sup>1</sup> / <sub>4</sub> "	44"	17"	17 <sup>1</sup> / <sub>2</sub> "	32"	19 <sup>1</sup> / <sub>4</sub> "	12 <sup>3</sup> / <sub>8</sub> "	N.A.

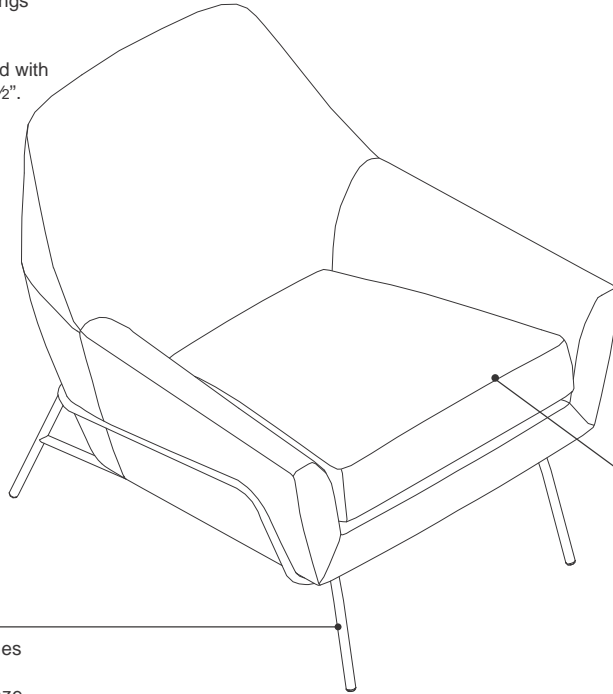
\*Overall width does not include the base.  
The diameter of the chair with the five-star base is 26".



# Lucas Seating

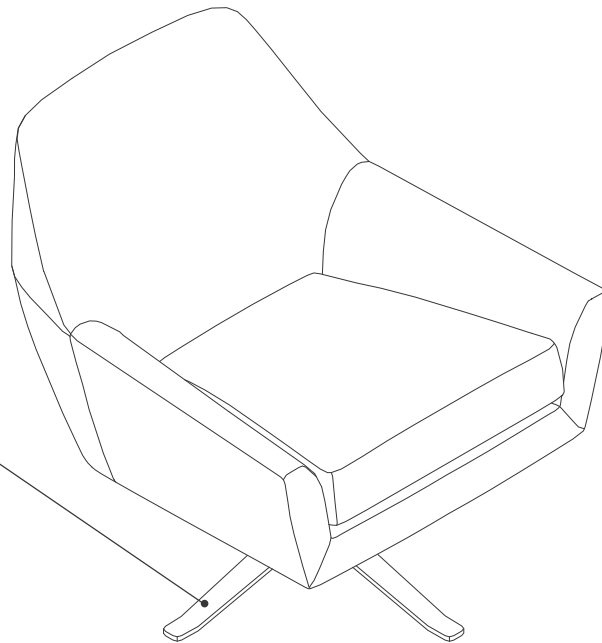
**Modern lines** give Lucas a streamlined look, while a wide seat and reclined pitch make it a comfortable spot to sit during long meetings and busy days.

**Lucas** comes standard with arms at a height of 20½".



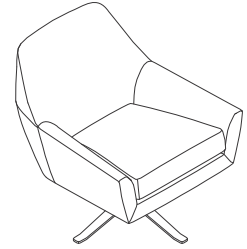
**The wire base** comes standard in West Elm WE05 Burnished Bronze with black glides.

**Seat height on wire base chair** is fixed at 18½".



**Swivel base** comes standard in 8046 Polished Aluminum. Swivel is a full 360° without an automatic return.

## Product Details



**Cushion** is detachable.

**All product in the Lucas product line** ships fully assembled.

## Surface Materials

**Swivel base** is 8046 Polished Aluminum.

**Wire base** is WE05 West Elm Burnished Bronze.

**Upholstery**  
• Billiard

**Contrasting fabric** is not available.

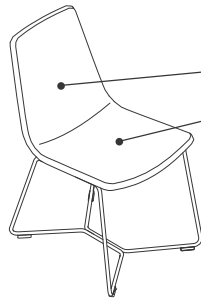
# Dimensions

## Lucas Seating

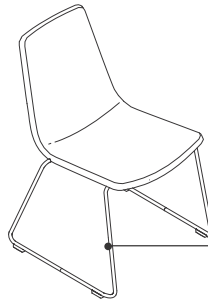
Features	Overall Depth	Width	Height	Seat Depth	Seat Width	Seat Height	Arm Height
<b>Lucas Seating</b>							
<b>Wire Base Chair</b>							
	32"	30½"	31"	21"	22"	18½"	20½"
<b>Swivel Base Chair</b>							
	32"	30½"	31"	21"	22"	20¾"	20½"

# Slope Seating

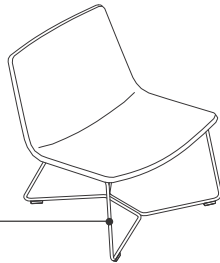
**Simple yet timeless design** allows the Slope family of seating to blend seamlessly into the modern office. A wide range of paint colors and upholstery options ranging from muted to playful add personality.



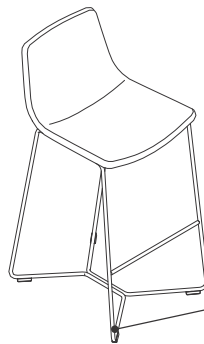
**Seat and back** are always fully upholstered.



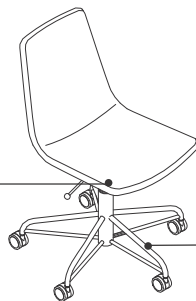
**Stackable base configuration** allows for easier storage and cleaning. Stacking chairs can be stacked up to five high.



**Wire frame base** is painted.



**Glides** are polyethylene for superior durability on carpeted and hard floors. Glides are available in black.



**Five-star base** is available in hot rolled steel finish or black paint.

**Seat height** adjusts 4", from 17½"H to 20½"H, with a pneumatic adjustment mechanism.

## Product Details



Guest chair



Stacking chair



Lounge chair



Bar-height stool



Conference chair

**Five-star and wire-frame bases** are available for guest chair and stool.

**360° adjustable height swivel mechanism** is standard on five-star base models.

**Slope** ships knocked down and the seat must be assembled to the frame on site, with the exception of the stacker with arms and the guest chair with arms which ship fully assembled. All slope styles come in a single carton.

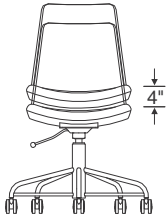
**Arms** are available as an option for guest, stacking, and conference chair.

**Slope stacking chairs** can be stacked up to five chairs high.

	Made-to-order	Stocked
Guest Chair	<b>AMQWESSLPCG</b>	<b>AMQWEM1</b>
Stacking Chair	<b>AMQWESSLPCS</b>	N.A.
Lounge Chair	<b>AMQWESSLPCL</b>	<b>AMQWEM2</b>
Conference Chair	<b>AMQWESSLPCC</b>	<b>AMQWEM3</b>
Bar Stool	<b>AMQWESSLPSB</b>	<b>AMQWEM66</b>

## Adjustment Features

### Seat Adjustments



### Conference Chair

#### Seat height adjusts

pneumatically. To lower, pull lever up while seated. To raise, pull lever up and keep your weight off the chair.

## Surface Materials

### Stocked Slope chairs

are only available in pre-configured base color and leather combinations. When Saddle or Fog leather are specified, the base will be Hot Rolled Steel. When Aegean leather is specified, the base will be Antique Brass.

### Seat and back upholstery

- Billiard

### Wire frame base

- Paint

### Five-star base

- 7207 Black
- Hot-rolled steel

### Casters

- 6205 Black

### Glides

- 6205 Black

### All seating with standard upholstery fabrics

complies with requirements of the State of California Technical Bulletin 117-2013. All standard seating is labeled to be in compliance with California 117-2013.

## Dimensions

► Page 482

# Dimensions

## Slope Seating

Features	Overall Depth	Width	Height	Functional Seat Depth	Seat Width	Seat Height from Floor	Back Width	Back Height from Seat
<b>Slope Seating</b>								
<b>Guest Chair</b>								
	21½"	19¼"	33¼"	17¾"	17¾"	18¾"	16¾"	18¾"
<b>Stacking Chair</b>								
	21½"	19¼"	33¼"	17¾"	17¾"	18¾"	16¾"	18¾"
<b>Lounge Chair</b>								
	26½"	26½"	28"	21¾"	26½"	15¾"	25¾"	19¼"
<b>Bar Stool</b>								
	21½"	19¼"	40"	17¾"	17¾"	29½"	14¼"	13"
<b>Conference Chair</b>								
	21½"	19¼"	32"–36"	17¾"	17¾"	17½"–20½"	16¾"	18¾"

\* Overall width does not include the base.  
 Tip: The diameter of the chair with the five-arm base is 25".

# Brighton One Seat Lounge Chair

Brighton One Seat  
Lounge Chair



*Tip: Handedness is determined while in the seated position.*

Standard Includes	Required to Specify
<ul style="list-style-type: none"> <li>Fully upholstered lounge chair: Billiard fabric</li> <li>Frame: paint</li> <li>Frame caps: paint</li> <li>Frame feet: paint</li> <li>Arms, if selected: veneer</li> </ul>	<ol style="list-style-type: none"> <li>Style number</li> <li>Fabric color number for chair</li> <li>Paint color number for frame</li> <li>Paint color number for frame caps</li> <li>Paint color number for frame feet</li> <li>Wood color number for arms, if selected</li> <li>Options, if selected (see below)</li> </ol> <p>▶ See <i>Surface Materials</i>, page 508.</p>

Options	U.S. Price	Required to Specify
<b>Arm Position</b> <ul style="list-style-type: none"> <li>No arm</li> <li>Arm left</li> <li>Arm right</li> <li>Arms – left and right</li> </ul>	No cost +\$260 +\$260 +\$519	Specify <i>with no arm</i> . Specify <i>with arm left</i> . Specify <i>with arm right</i> . Specify <i>with arms – left and right</i> .
<b>Ganging</b> <ul style="list-style-type: none"> <li>Not ganging</li> <li>Left</li> <li>Right</li> <li>Left and right</li> </ul>	No cost +\$ 61 +\$ 61 +\$122	Specify <i>with no arm</i> . Specify <i>with arm left</i> . Specify <i>with arm right</i> . Specify <i>with arms – left and right</i> .

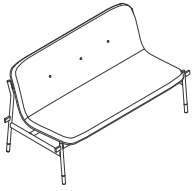
## Specification Information

Style Number	U.S. Base Price
AMQWESARYLNG1	\$2480

West Elm Seating

**For Canadian Pricing**  
 Multiply U.S. Price by the Canadian price factor.  
 ▶ See page 1 for details.

# Brighton Two Seat Lounge Chair



Tip: Handedness is determined while in the seated position.

Standard Includes	Required to Specify
<ul style="list-style-type: none"> <li>Fully upholstered lounge chair: Billiard fabric</li> <li>Frame: paint</li> <li>Frame caps: paint</li> <li>Frame feet: paint</li> <li>Arms, if selected: veneer</li> </ul>	<ol style="list-style-type: none"> <li>Style number</li> <li>Fabric color number for chair</li> <li>Paint color number for frame</li> <li>Paint color number for frame caps</li> <li>Paint color number for frame feet</li> <li>Wood color number for arms, if selected</li> <li>Options, if selected (see below)</li> </ol> <p>▶ See <i>Surface Materials</i>, page 508.</p>

Options	U.S. Price	Required to Specify
<b>Arm Position</b> <ul style="list-style-type: none"> <li>No arm</li> <li>Arm left</li> <li>Arm right</li> <li>Arms – left and right</li> </ul>	No cost +\$260 +\$260 +\$519	Specify <i>with no arm</i> . Specify <i>with arm left</i> . Specify <i>with arm right</i> . Specify <i>with arms – left and right</i> .
<b>Ganging</b> <ul style="list-style-type: none"> <li>Not ganging</li> <li>Left</li> <li>Right</li> <li>Left and right</li> </ul>	No cost +\$ 61 +\$ 61 +\$122	Specify <i>with no arm</i> . Specify <i>with arm left</i> . Specify <i>with arm right</i> . Specify <i>with arms – left and right</i> .

Specification Information	
Style Number	U.S. Base Price
AMQWESARYLNG2	\$3728



**For Canadian Pricing**  
 Multiply U.S. Price by the Canadian price factor.  
 ▶ See page 1 for details.



Tip: Handedness is determined while in the seated position.

Standard Includes	Required to Specify
-------------------	---------------------

- Fully upholstered ottoman chair: Billiard fabric
- Frame: paint
- Frame caps: paint

- 1 Style number
  - 2 Fabric color number for ottoman
  - 3 Paint color number for frame
  - 4 Paint color number for frame caps
- ▶ See *Surface Materials*, page 508.

Specification Information	
Style Number	U.S. Price
AMQWESARYO	\$764

Style Number	U.S. Price
AMQWESARYO	\$764



**For Canadian Pricing**  
 Multiply U.S. Price by the Canadian price factor.  
 ▶ See page 1 for details.

# Brighton 90° Ganging Table



*Tip: Ganging tables or end table must be used when specifying ganging hardware on lounge units. Ganging hardware and arms cannot be specified on the same side of a lounge unit.*

Standard Includes	Required to Specify
<ul style="list-style-type: none"> <li>• Table: High-Pressure Laminate with 3 mm plastic edge</li> <li>• Frame: paint</li> <li>• Frame feet: paint</li> <li>• Plastic ganging brackets</li> </ul>	<ol style="list-style-type: none"> <li>1 Style number</li> <li>2 High-Pressure Laminate color number for table</li> <li>3 Plastic color number for edge</li> <li>4 Paint color number for frame</li> <li>5 Paint color number for feet</li> </ol> <p>▶ See <i>Surface Materials</i>, page 506.</p>

Specification Information	
• Style Number	• U.S. Price
<b>AMQWESARYTBL90</b>	\$1337



**For Canadian Pricing**  
 Multiply U.S. Price by the Canadian price factor.  
 ▶ See page 1 for details.

# Brighton Straight Ganging Table

Brighton Straight  
Ganging Table



*Tip: Ganging tables or end table must be used when specifying ganging hardware on lounge units. Ganging hardware and arms cannot be specified on the same side of a lounge unit.*

Standard Includes	Required to Specify
<ul style="list-style-type: none"> <li>• Table: High-Pressure Laminate with 3 mm plastic edge</li> <li>• Frame: paint</li> <li>• Ganging brackets: plastic</li> </ul>	<ul style="list-style-type: none"> <li>1 Style number</li> <li>2 High-Pressure Laminate color number for table</li> <li>3 Plastic color number for edge</li> <li>▶ See <i>Surface Materials</i>, page 506.</li> </ul>

Specification Information	
• Style • Number	• U.S. • Price
<b>AMQWESARYTBLSG</b>	\$1263
•	•

West Elm Seating

 **For Canadian Pricing**  
Multiply U.S. Price by the Canadian price factor.  
▶ See page 1 for details.

# Brighton End Table



*Tip: Ganging tables or end table must be used when specifying ganging hardware on lounge units. Ganging hardware and arms cannot be specified on the same side of a lounge unit.*

Standard Includes	Required to Specify
<ul style="list-style-type: none"> <li>Table: High-Pressure Laminate with 3 mm plastic edge</li> <li>Frame: paint</li> <li>Frame feet: paint</li> <li>Frame caps: paint</li> <li>Ganging brackets: plastic</li> </ul>	<ol style="list-style-type: none"> <li>Style number</li> <li>High-Pressure Laminate color number for table</li> <li>Plastic color number for edge</li> <li>Paint color number for frame</li> <li>Paint color number for frame feet</li> <li>Paint color number for frame caps</li> <li>Options, if selected (see below)</li> </ol> <p>▶ See <i>Surface Materials</i>, page 506.</p>

	Options	U.S. Price	Required to Specify
<b>Ganging</b>	<ul style="list-style-type: none"> <li>Left</li> <li>Right</li> </ul>	<p>No cost</p> <p>No cost</p>	<p>Specify <i>with ganging left</i>.</p> <p>Specify <i>with ganging right</i>.</p>

Specification Information	
Style Number	U.S. Price
<b>AMQWESARYTBLED</b>	\$1403



**For Canadian Pricing**  
 Multiply U.S. Price by the Canadian price factor.  
 ▶ See page 1 for details.

# Brighton Square Table

Brighton Square Table



*Tip: Ganging tables or end table must be used when specifying ganging hardware on lounge units. Ganging hardware and arms cannot be specified on the same side of a lounge unit.*

Standard Includes	Required to Specify
-------------------	---------------------

- |  |   |
|--|---|
| <ul style="list-style-type: none"> <li>• Table: High-Pressure Laminate with 3 mm plastic edge</li> <li>• Frame: paint</li> <li>• Frame caps: paint</li> <li>• Frame feet: paint</li> </ul> | <ul style="list-style-type: none"> <li>1 Style number</li> <li>2 High-Pressure Laminate color number for table</li> <li>3 Plastic color number for edge</li> <li>4 Paint color number for frame</li> <li>5 Paint color number for frame feet</li> <li>6 Paint color number for frame caps</li> <li>▶ See <i>Surface Materials</i>, page 506.</li> </ul> |
|--|---|

Specification Information	
Style Number	U.S. Price

AMQWESARYTBLSQ	\$1547
----------------	--------

West Elm Seating



**For Canadian Pricing**  
 Multiply U.S. Price by the Canadian price factor.  
 ▶ See page 1 for details.

# Brighton Rectangle Table



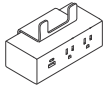
Standard Includes	Required to Specify
-------------------	---------------------

- |  |   |
|--|---|
| <ul style="list-style-type: none"> <li>• Table: High-Pressure Laminate with 3 mm plastic edge</li> <li>• Frame: paint</li> <li>• Frame caps: paint</li> <li>• Frame feet: paint</li> </ul> | <ul style="list-style-type: none"> <li>1 Style number</li> <li>2 High-Pressure Laminate color number for table</li> <li>3 Plastic color number for edge</li> <li>4 Paint color number for frame</li> <li>5 Paint color number for frame feet</li> <li>6 Paint color number for frame caps</li> <li>▶ See <i>Surface Materials</i>, page 506.</li> </ul> |
|--|---|

Specification Information	
• Style Number	• U.S. Price
<b>AMQWESARYTBLRT</b>	\$1758



**For Canadian Pricing**  
 Multiply U.S. Price by the  
 Canadian price factor.  
 ▶ See page 1 for details.



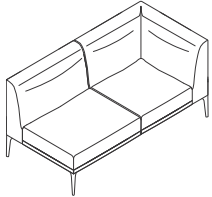
Standard Includes	Required to Specify
<ul style="list-style-type: none"> <li>• 9' cord with three-prong plug: black plastic only</li> <li>• 2 power 1 USB A+C 20W power module: 6000 Black</li> </ul>	Style number

Specification Information	
• Style Number	• U.S. Price
<b>AMQWESARYPWR</b>	\$460

 **For Canadian Pricing**  
 Multiply U.S. Price by the Canadian price factor.  
 ▶ See page 1 for details.

# Mesa Lounge System

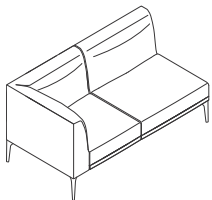
## Mesa Chaise Lounge—Left Hand



*Tip: Handedness is determined while in the seated position.*

Standard Includes		Required to Specify
<ul style="list-style-type: none"> <li>Fully upholstered non-contrasting lounge: Billiard fabric</li> <li>Four leg cast aluminum base: WE01 Antique Bronze</li> <li>Ganging brackets: plastic</li> </ul>		1 Style number 2 Fabric color number for lounge ▶ See <i>Surface Materials</i> , page 508.
Specification Information		
Style Number	U.S. Price	
AMQWESMESCHLH	\$5856	

## Mesa Chaise Lounge—Right Hand



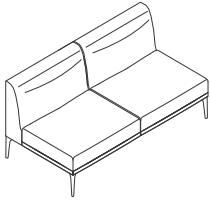
*Tip: Handedness is determined while in the seated position.*

Standard Includes		Required to Specify
<ul style="list-style-type: none"> <li>Fully upholstered non-contrasting lounge: Billiard fabric</li> <li>Four leg cast aluminum base: WE01 Antique Bronze</li> <li>Ganging brackets: plastic</li> </ul>		1 Style number 2 Fabric color number for lounge ▶ See <i>Surface Materials</i> , page 508.
Specification Information		
Style Number	U.S. Price	
AMQWESMESCHRH	\$5856	



**For Canadian Pricing**  
 Multiply U.S. Price by the Canadian price factor.  
 ▶ See page 1 for details.

## Mesa Armless Lounge



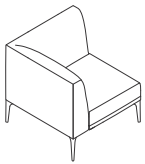
Standard Includes	Required to Specify
-------------------	---------------------

- |  |   |
|--|---|
| <ul style="list-style-type: none"> <li>Fully upholstered non-contrasting lounge: Billiard fabric</li> <li>Four leg cast aluminum base: WE01 Antique Bronze</li> <li>Ganging brackets: plastic</li> </ul> | <ul style="list-style-type: none"> <li>1 Style number</li> <li>2 Fabric color number for lounge</li> <li>▶ See <i>Surface Materials</i>, page 508.</li> </ul> |
|--|---|

Specification Information	
---------------------------	--

Style Number	U.S. Price
AMQWESMES2SEAT	\$5320

## Mesa Corner Lounge Unit



Standard Includes	Required to Specify
-------------------	---------------------

- |  |   |
|--|---|
| <ul style="list-style-type: none"> <li>Fully upholstered non-contrasting lounge: Billiard fabric</li> <li>Four leg cast aluminum base: WE01 Antique Bronze</li> <li>Ganging brackets: plastic</li> </ul> | <ul style="list-style-type: none"> <li>1 Style number</li> <li>2 Fabric color number for lounge</li> <li>▶ See <i>Surface Materials</i>, page 508.</li> </ul> |
|--|---|

Specification Information	
---------------------------	--

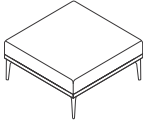
Style Number	U.S. Price
AMQWESMESC	\$3453

West Elm Seating



**For Canadian Pricing**  
 Multiply U.S. Price by the Canadian price factor.  
 ▶ See page 1 for details.

**Mesa Ottoman**



Standard Includes	Required to Specify
-------------------	---------------------

- Fully upholstered ottoman: Billiard fabric
- Four leg cast aluminum base: WE01 Antique Bronze

- 1 Style number
- 2 Fabric color number for lounge
- ▶ See *Surface Materials*, page 508.

Specification Information	
Style Number	U.S. Price

Style Number	U.S. Price
<b>AMQWESMESO</b>	\$2354



**For Canadian Pricing**

Multiply U.S. Price by the Canadian price factor.

▶ See page 1 for details.

# Nimbus Conference Chair

Nimbus Conference Chair



Standard Includes	Required to Specify
-------------------	---------------------

- Fully upholstered seat: platinum
- 5-star base: antique bronze

Style number

Specification Information	
Style Number	U.S. Price

AMQWEM70	\$1187
----------	--------

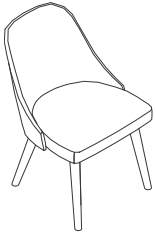
West Elm Seating



**For Canadian Pricing**  
 Multiply U.S. Price by the  
 Canadian price factor.  
 ▶ See page 1 for details.

# Sterling Chairs

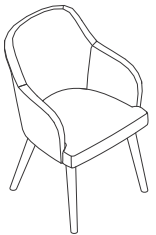
## Sterling 4-Leg Armless Guest Chair



*Tip: Seat and back finish are non-contrasting and will match.*

Standard Includes		Required to Specify
<ul style="list-style-type: none"> <li>Fully upholstered non-contrasting chair: Billiard fabric</li> <li>Legs: VP03 Black Oak</li> <li>Glides</li> </ul>		1 Style number 2 Fabric color number for chair ▶ See <i>Surface Materials</i> , page 508.
Specification Information		
Style Number	U.S. Price	
AMQWESMDC4NA	\$1270	

## Sterling 4-Leg with Arms Guest Chair



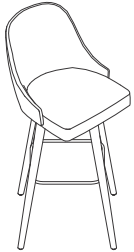
*Tip: Seat and back finish are non-contrasting and will match.*

Standard Includes		Required to Specify
<ul style="list-style-type: none"> <li>Fully upholstered non-contrasting chair: Billiard fabric</li> <li>Legs: VP03 Black Oak</li> <li>Glides</li> </ul>		1 Style number 2 Fabric color number for chair ▶ See <i>Surface Materials</i> , page 508.
Specification Information		
Style Number	U.S. Price	
AMQWESMDC4WA	\$1421	



**For Canadian Pricing**  
 Multiply U.S. Price by the Canadian price factor.  
 ▶ See page 1 for details.

## Sterling Bar Height Armless Stool



Tip: Seat and back finish are non-contrasting and will match.

Standard Includes		Required to Specify
<ul style="list-style-type: none"> <li>Fully upholstered non-contrasting lounge: Billiard fabric</li> <li>Legs: VP03 Black Oak</li> <li>Glides</li> </ul>		1 Style number 2 Fabric color number for stool ▶ See <i>Surface Materials</i> , page 508.
Specification Information		
Style Number	U.S. Price	
AMQWESMDCSBHNA	\$1620	

## Sterling 5-Star Armless Conference Chair



Tip: Seat and back finish are non-contrasting and will match.

Standard Includes		Required to Specify
<ul style="list-style-type: none"> <li>Fully upholstered non-contrasting chair: Billiard fabric</li> <li>Five star base: 0835 Black</li> <li>Hard casters: 6205 Black</li> </ul>		1 Style number 2 Fabric color number for chair 3 Options, if selected (see below) ▶ See <i>Surface Materials</i> , page 508.
Options	U.S. Price	Required to Specify
<b>Surface Materials</b>	<b>Base</b>	
	<ul style="list-style-type: none"> <li>Polished aluminum</li> </ul>	+\$136 Specify <i>with polished aluminum</i> .
<b>Tilt Mechanism</b>	<ul style="list-style-type: none"> <li>Without tilt</li> <li>With tilt</li> </ul>	No cost +\$106 Specify <i>without tilt</i> . Specify <i>with tilt</i> .
Specification Information		
Style Number	U.S. Base Price	
AMQWESMDC5NA	\$1422	



**For Canadian Pricing**  
 Multiply U.S. Price by the Canadian price factor.  
 ▶ See page 1 for details.

**Sterling 5-Star with Arms Conference Chair**



*Tip: Seat and back finish are non-contrasting and will match.*

Standard Includes	Required to Specify
-------------------	---------------------

- |  |   |
|--|---|
| <ul style="list-style-type: none"> <li>Fully upholstered non-contrasting chair: Billiard fabric</li> <li>Five star base: 0835 Black</li> <li>Hard casters: 6205 Black</li> </ul> | <ol style="list-style-type: none"> <li>Style number</li> <li>Fabric color number for chair</li> <li>Paint color number for base</li> <li>Options, if selected (see below)</li> </ol> <p>▶ See <i>Surface Materials</i>, page 508.</p> |
|--|---|

Options	U.S. Price	Required to Specify
---------	------------	---------------------

<b>Surface Materials</b>	<b>Base</b>	
	<ul style="list-style-type: none"> <li>Polished aluminum</li> </ul>	+\$136
		Specify <i>with polished aluminum</i> .
<b>Tilt Mechanism</b>		
	<ul style="list-style-type: none"> <li>Without tilt</li> <li>With tilt</li> </ul>	No cost +\$106
		Specify <i>without tilt</i> . Specify <i>with tilt</i> .

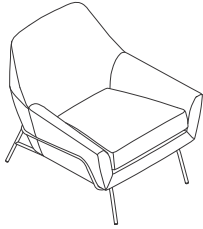
Specification Information	
---------------------------	--

Style Number	U.S. Base Price
AMQWESMDC5WA	\$1557



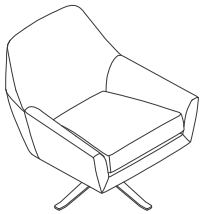
**For Canadian Pricing**  
 Multiply U.S. Price by the Canadian price factor.  
 ▶ See page 1 for details.

## Lucas Wire Chair



Standard Includes		Required to Specify
<ul style="list-style-type: none"> <li>Fully upholstered seat with back: Billiard fabric</li> <li>Wire frame base: WE05 West Elm Burnished Bronze</li> </ul>		1 Style number 2 Fabric color number for chair ▶ See <i>Surface Materials</i> , page 508.
Specification Information		
Style Number	U.S. Price	
AMQWESLUCW	\$3021	

## Lucas Swivel Chair



Standard Includes		Required to Specify
<ul style="list-style-type: none"> <li>Fully upholstered seat with back: Billiard fabric</li> <li>Swivel base: 8046 Polished Aluminum</li> </ul>		1 Style number 2 Fabric color number for chair ▶ See <i>Surface Materials</i> , page 508.
Specification Information		
Style Number	U.S. Price	
AMQWESLUCS	\$3239	

West Elm Seating

 **For Canadian Pricing**  
 Multiply U.S. Price by the Canadian price factor.  
 ▶ See page 1 for details.

# Slope Chairs

## Slope Guest Chair



Tip: Slope guest chair with arms is shipped fully assembled; without arms will require assembly.

Tip: Upholstery and paint available on Steelcase Slope. Licensed Slope (stocked) guest chair available in saddle or fog with a hot rolled steel frame.

Standard Includes		Required to Specify	
-------------------	--	---------------------	--

- Fully upholstered seat with back: Billiard fabric
- Wire frame base: paint price group 1
- Glides: 6205 Black

- 1 Style number
  - 2 Fabric color number for chair
  - 3 Paint color number for base
  - 4 Options, if selected (see below)
- ▶ See *Surface Materials*, page 508.

	Options	U.S. Price	Required to Specify
--	---------	------------	---------------------

<b>Surface Materials</b>	<b>Base</b>		
	• Paint price group 1	No cost	Specify paint color number.
	• Paint price group 2	+\$ 44	Specify paint color number.

<b>Arm</b>	• Without arm	No cost	Specify <i>without arms</i> .
	• With arm	+\$173	Specify <i>with arms</i> .

### Specification Information

• Style Number	• U.S. Base Price
AMQWESSLPCG	\$987

## Slope Lounge Chair



Tip: Upholstery and paint available on Steelcase Slope. Licensed Slope (stocked) lounge chair only available in saddle with hot rolled steel frame.

Standard Includes		Required to Specify	
-------------------	--	---------------------	--

- Fully upholstered seat with back: Billiard fabric
- Wire frame base: paint price group 1
- Glides: 6205 Black
- Requires assembly

- 1 Style number
  - 2 Fabric color number for chair
  - 3 Paint color number for base
  - 4 Options, if selected (see below)
- ▶ See *Surface Materials*, page 508.

	Options	U.S. Price	Required to Specify
--	---------	------------	---------------------

<b>Surface Materials</b>	<b>Base</b>		
	• Paint price group 1	No cost	Specify paint color number.
	• Paint price group 2	+\$44	Specify paint color number.

### Specification Information

• Style Number	• U.S. Base Price
AMQWESSLPCL	\$1365



**For Canadian Pricing**  
Multiply U.S. Price by the Canadian price factor.  
▶ See page 1 for details.

## Slope Bar Height Stool



*Tip: Upholstery and paint available on Steelcase Slope. Licensed Slope (stocked) bar height stool is only available in saddle with hot rolled steel frame.*

Standard Includes		Required to Specify	
<ul style="list-style-type: none"> <li>Fully upholstered seat with back: Billiard fabric</li> <li>Wire frame base: paint price group 1</li> <li>Glides: 6205 Black</li> <li>Requires assembly</li> </ul>		<ul style="list-style-type: none"> <li>1 Style number</li> <li>2 Fabric color number for chair</li> <li>3 Paint color number for base</li> <li>4 Options, if selected (see below)</li> <li>▶ See <i>Surface Materials</i>, page 508.</li> </ul>	
Surface Materials	Options	U.S. Price	Required to Specify
	<b>Base</b> <ul style="list-style-type: none"> <li>Paint price group 1</li> <li>Paint price group 2</li> </ul>	No cost +\$44	Specify paint color number. Specify paint color number.
Specification Information			
• Style Number	• U.S. Base Price		
AMQWESSLPSB	\$1276		

## Slope Height-Adjustable Conference Chair



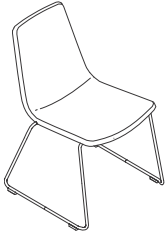
*Tip: Upholstery and paint available on Steelcase Slope. Licensed Slope (stocked) conference chair only available in saddle with hot rolled steel frame.*

Standard Includes		Required to Specify	
<ul style="list-style-type: none"> <li>Fully upholstered seat with back: Billiard fabric</li> <li>Five-star adjustable base: hot-rolled steel finish</li> <li>Hard casters: 6205 Black</li> <li>Requires assembly</li> </ul>		<ul style="list-style-type: none"> <li>1 Style number</li> <li>2 Fabric color number for chair</li> <li>3 Options, if selected (see below)</li> <li>▶ See <i>Surface Materials</i>, page 508.</li> </ul>	
Arm	Options	U.S. Price	Required to Specify
	<ul style="list-style-type: none"> <li>Without arm</li> <li>With arm</li> </ul>	No cost +\$173	Specify <i>without arms</i> . Specify <i>with arms</i> .
Specification Information			
• Style Number	• U.S. Base Price		
AMQWESSLPCC	\$1334		



**For Canadian Pricing**  
 Multiply U.S. Price by the Canadian price factor.  
 ▶ See page 1 for details.

### Slope Stacking Chair



*Tip: Slope stacking chair with arms is shipped fully assembled; without arms will require assembly.*

Standard Includes		Required to Specify	
<ul style="list-style-type: none"> <li>Fully upholstered seat with back: Billiard fabric</li> <li>Wire frame base: paint price group 1</li> <li>Glides: 6205 Black</li> </ul>		<ul style="list-style-type: none"> <li>1 Style number</li> <li>2 Fabric color number for chair</li> <li>3 Paint color number for base</li> <li>4 Options, if selected (see below)</li> <li>▶ See <i>Surface Materials</i>, page 508.</li> </ul>	
Options		U.S. Price	Required to Specify
<b>Surface Materials</b>	<b>Base</b>		
	<ul style="list-style-type: none"> <li>Paint price group 1</li> <li>Paint price group 2</li> </ul>	No cost +\$ 44	Specify paint color number. Specify paint color number.
<b>Arm</b>	<ul style="list-style-type: none"> <li>Without arm</li> <li>With arm</li> </ul>	No cost +\$173	Specify <i>without arms</i> . Specify <i>with arms</i> .
	Specification Information		
Style Number	U.S. Base Price		
AMQWESSLPCS	\$999		

### Slope Guest Chair—Stocked



*Tip: Licensed Slope (stocked) guest chair available in saddle or fog with a hot rolled steel frame.*

Standard Includes		Required to Specify		
<ul style="list-style-type: none"> <li>Fully upholstered seat with back: fog or saddle</li> <li>Wire frame base: WE00 Hot Rolled Steel</li> </ul>		<ul style="list-style-type: none"> <li>1 Style number</li> <li>2 Color number for chair</li> </ul>		
Specification Information				
Style Number	Dimensions			U.S. Price
	D	W	H	
AMQWEM1	21½"	19¼"	33¼"	\$1022



**For Canadian Pricing**  
Multiply U.S. Price by the Canadian price factor.  
▶ See page 1 for details.

## Slope Lounge Chair—Stocked



### Standard Includes

- Fully upholstered seat with back: saddle leather
- Wire frame base: WE00 Hot Rolled Steel

### Required to Specify

- 1 Style number
- 2 Color number for chair

### Specification Information

• Style Number	• Dimensions			• U.S. Price
	D	W	H	
AMQWEM2	24 <sup>2</sup> / <sub>5</sub> "	26 <sup>1</sup> / <sub>2</sub> "	31 <sup>1</sup> / <sub>2</sub> "	\$1293

## Slope Bar Stool—Stocked



### Standard Includes

- Fully upholstered seat with back: saddle leather
- Wire frame base: WE00 Hot Rolled Steel

### Required to Specify

- Style number

### Specification Information

• Style Number	• Dimensions			• U.S. Price
	D	W	H	
AMQWEM66	21 <sup>1</sup> / <sub>2</sub> "	19 <sup>1</sup> / <sub>4</sub> "	40"	\$1113



### For Canadian Pricing

Multiply U.S. Price by the Canadian price factor.

▶ See page 1 for details.

**Slope Conference Chair—Stocked**



Standard Includes	Required to Specify
-------------------	---------------------

- Fully upholstered seat with back: saddle leather
- Five-star adjustable base: WE00 Hot Rolled Steel

- 1 Style number
- 2 Color number for chair

Specification Information				
• Style • Number	• Dimensions			• U.S. • Price
	D	W	H	

AMQWEM3	21½"	19¼"	32"–36"	\$1293
---------	------	------	---------	--------

---

# Resources

<b>Furniture Finishes</b>	<b>506</b>
<b>Seating Finishes</b>	<b>508</b>
<b>Style Number Index</b>	<b>510</b>

# Furniture Finishes

## Fabric Verve Collection



FB1 Briquette    FB2 Shadow    FB3 Ash    FB4 Pearl    FB5 Celestial    FB9 Sand    FB10 Seafoam

## Felt Verve Collection



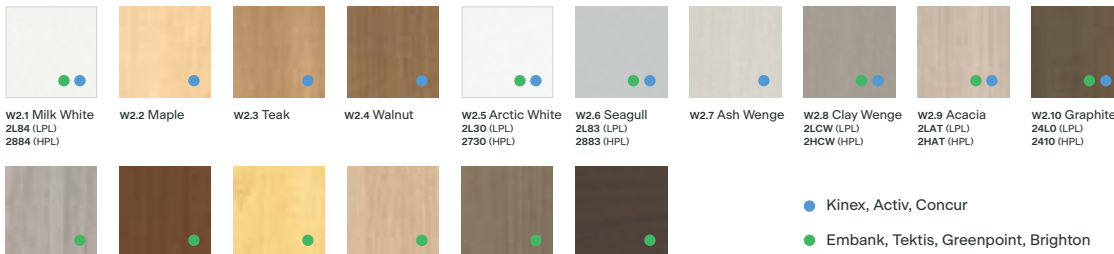
FC1 Briquette    FC2 Shadow    FC3 Ash    FC4 Pearl    FC5 Celestial    FC9 Sand    FC10 Seafoam    FC11 Warm White    FC12 Midnight

## Metals



F1 Platinum    F2 White    F3 Black    F4 Merle    7207 Black    4799 Platinum Metallic    7243 Seagull    7225 Sand    7238 Fieldstone

## Laminates



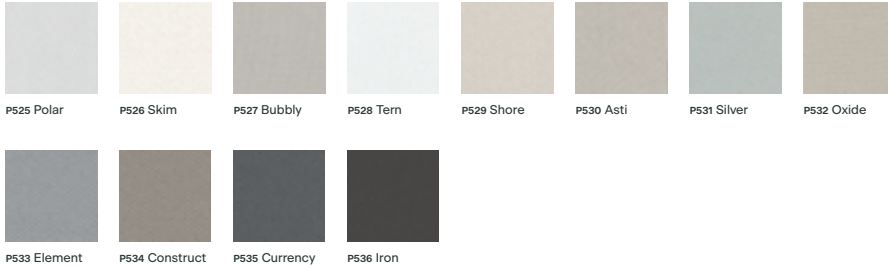
W21 Milk White 2L84 (LPL) 2884 (HPL)    W2.2 Maple    W2.3 Teak    W2.4 Walnut    W2.5 Arctic White 2L30 (LPL) 2730 (HPL)    W2.6 Seagull 2L83 (LPL) 2883 (HPL)    W2.7 Ash Wenge    W2.8 Clay Wenge 2LCW (LPL) 2HCW (HPL)    W2.9 Acacia 2LAT (LPL) 2HAT (HPL)    W2.10 Graphite Walnut 24L0 (LPL) 2410 (HPL)

Clay Noce 2LCN (LPL) 2HCN (HPL)    Natural Cherry 26L1 (LPL) 2412 (HPL)    Clear Maple 2L09 (LPL) 2409 (HPL)    Clear Oak 2LAK (LPL) 2HAK (HPL)    Virginia Walnut 25L5 (LPL) 2535 (HPL)    Clear Walnut 25L8 (LPL) 2538 (HPL)

● Kinex, Activ, Concur  
● Embank, Tektis, Greenpoint, Brighton

**Note** Please view material swatches before specifying. Printed colors may vary from actual fabric. View material specs and cleaning instructions on our web site at [www.amqsolutions.com](http://www.amqsolutions.com)

## Fabric Alloy Collection



## Fabric Boccie Collection



## Designtex Billiard Multi-Use Collection



**Note** Please view material swatches before specifying. Printed colors may vary from actual fabric.  
View material specs and cleaning instructions on our web site at [www.amqsolutions.com](http://www.amqsolutions.com)

# Seating Finishes

## Fabric Buzz Collection Grade 1



Fabric Specifications	
Content	100% Polyester (Antimony Free Yarn)*
Weight	14.5 oz. per linear yard
Width	54 inches
Abrasion	100,000 double rubs
Environmental Characteristics	*Antimony Less Than 100 ppm
Flammability	California Technical Bulletin #133



## Fabric Era Collection Grade 2



Fabric Specifications	
Content	100% Polyester (Antimony Free Yarn)*
Weight	14.24 oz. per linear yard
Width	54 inches
Abrasion	100,000 double rubs
Environmental Characteristics	*Antimony Less Than 100 ppm, Oeko-Tex Certified
Flammability	California Technical Bulletin #133



## Fabric Connect Collection Grade 3



Fabric Specifications	
Content	100% Polyester (Antimony Free Yarn)*
Weight	16.4 oz. per linear yard
Width	62 inches
Abrasion	100,000 double rubs
Environmental Characteristics	*Antimony Less Than 100 ppm, Cradle to Cradle Certified™ Bronze
Flammability	California Technical Bulletin #133



**Note** Please view material swatches before specifying. Printed colors may vary from actual fabric. View material specs and cleaning instructions on our web site at [www.amqsolutions.com](http://www.amqsolutions.com)

## Polyurethane Brisa Collection Grade 4

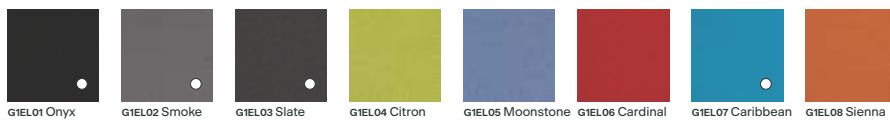


### Fabric Specifications

Content	100% Polyurethane
Weight	13.8 ozs per linear yard
Width	54 inches
Abrasion	200,000 double rubs
Environmental Characteristics	Bleach Cleanable
Flammability	California Technical Bulletin #133



## Fabric Elements Collection Grade 1



**FI-X**  FL-X fabric back colors indicated with white dot

### Fabric Specifications

Content	98% Recycled Polyester, 2% Spandex
Weight	(per sq. m) 326g
Thickness	1.1mm
Width	58"
Flammability	California Bulletin 117. Section E CS 191-53 Class 1

## Fabric Milan Collection Grade 2



**FI-X**  FL-X fabric back colors indicated with white dot

### Fabric Specifications

Content	100% Polyester
Weight	(per sq. m) 243g
Width	58"
Flammability	California Bulletin 117. Section E

## Vinyl Grade 4



**FI-X**

**Note** Please view material swatches before specifying. Printed colors may vary from actual fabric. View material specs and cleaning instructions on our web site at [www.amqsolutions.com](http://www.amqsolutions.com)

# Style Number Index

Style Number	Page	Description
<b>3FHPHANGINGPNL</b>	109	3F Hanging Panel
<b>3FHPMOUNTKIT</b>	116	3F Pnl Rail Mount Kit
<b>3FHPRAILKIT</b>	116	3F Pnl Rail Mount Kit
<b>3FSNCORNERCNECT</b>	117	3F Screens Corner Connector
<b>3FSNFIXEDPRVCYBKT</b>	118	3F Scrns Pvcy Mod Scrns Bracket
<b>3FSNHALFDESK</b>	113	3F Half Desk L-Screen
<b>3FSNHEIGHTADJBKT</b>	119	3F Screens Height AdjBracket
<b>3FSNHOODED</b>	115	3F Hooded Screen
<b>3FSNILINEMOUNT</b>	119	3F Screen,ILINE Scrn Mnt Clip,Set of 2
<b>3FSNKINEXCLIP</b>	119	3F Scrns KINEX Scrn Clip
<b>3FSNLBKT</b>	118	3F Modesty and Privacy L-Bracket
<b>3FSNLINER</b>	111	3F Linear Screen
<b>3FSNLSCREEN</b>	112	3F Full Desk L-Screen
<b>3FSNMB</b>	120	Markerboard
<b>3FSNSLEEVEBKT</b>	117	3F Screens Sleeve Bracket
<b>3FSNTOPMNTCLAMPBKT</b>	118	3F Scrns Top Mnt Bracket Clamp
<b>3FSNTOPMOUNTBKT</b>	117	3F Screens Top Mount Bracket
<b>3FSNUSCREEN</b>	114	3F U-Screen
<b>3FWTTILE</b>	110	3F Wall Tile
<b>ACTIV-CASTORS</b>	76	ACTIV Castors for Bases
<b>ACTVRETURNWKSF</b>	77	ACTIV Return Worksurface
<b>ACTVWIRETRAY</b>	160	ACTIV Wire Tray 36"W
<b>ACTVWORKSURF120</b>	77	ACTIV 120 Degree Worksurface
<b>ACTVWORKSURFACE</b>	76	ACTIV Worksurface
<b>AMQ999CHT</b>	412	Greenpoint Wire Clip
<b>AMQAWAK</b>	377	EMBANK Cabinet Attachment Kit
<b>AMQAWM30</b>	412	Greenpoint Wire Manager
<b>AMQCDWS</b>	266	Tektis- Cord Drop Worksurfaces
<b>AMQCFINTRO</b>	161	WORK TOOLS Intro Single
<b>AMQCFINTRODSLIDE</b>	162	WORK TOOLS Intro Dual Assembly
<b>AMQCRBK</b>	363	EMBANK Bookcase
<b>AMQCRBKS</b>	364	EMBANK Stacking Bookcase
<b>AMQCRBRG</b>	357	EMBANK Bridge
<b>AMQCRC</b>	345	EMBANK Mobile Ped Cushion
<b>AMQCRCD2HFSCC</b>	351	EMBANK Two-High Credenza
<b>AMQCRCD2HFSLCLFL</b>	351	EMBANK Two-High Credenza
<b>AMQCRCD2HFSLCLFR</b>	351	EMBANK Two-High Credenza
<b>AMQCRCD2HFSLFL</b>	350	EMBANK Two-High Credenza
<b>AMQCRCD2HFSLFR</b>	350	EMBANK Two-High Credenza
<b>AMQCRCD2HFSLLL</b>	351	EMBANK Two-High Credenza
<b>AMQCRCD2HFSSO</b>	350	EMBANK Two-High Credenzas
<b>AMQCRCD2HKSDP</b>	352	EMBANK Two-High Credenza
<b>AMQCRCD2HKSSPL</b>	352	EMBANK Two-High Credenza
<b>AMQCRCD2HKSSPR</b>	352	EMBANK Two-High Credenza
<b>AMQCRCT</b>	353	EMBANK Common Top
<b>AMQCRDShL</b>	354	EMBANK Desk Shell
<b>AMQCRDskDP</b>	355	EMBANK Desk Shell
<b>AMQCRDskSPL</b>	355	EMBANK Desk Shell
<b>AMQCRDskSPR</b>	355	EMBANK Desk Shell
<b>AMQCRDWKSF</b>	358	EMBANK D-Shaped WS
<b>AMQCRL15HBF</b>	346	EMBANK 1.5-High Lateral File
<b>AMQCRL1H</b>	346	EMBANK 1-High Lateral File
<b>AMQCRL2H</b>	346	EMBANK 2-High Lateral File
<b>AMQCRL3H</b>	347	EMBANK 3-High Lateral File
<b>AMQCRL4H</b>	347	EMBANK 4-High Lateral File

Style Number	Page	Description
<b>AMQCRLS15HO</b>	348	EMBANK 1.5-High Lower Storage
<b>AMQCRLS1H</b>	348	EMBANK 1-High Lower Storage
<b>AMQCRLS2HD</b>	348	EMBANK 2-High Lower Storage
<b>AMQCRLS2HO</b>	348	EMBANK 2-High Lower Storage
<b>AMQCRMP</b>	376	EMBANK Modesty Panel
<b>AMQCRMP15H</b>	345	EMBANK 1.5-High Mobile Ped
<b>AMQCRMP2HBBF</b>	345	EMBANK 2-High Mobile Ped
<b>AMQCRMP2HFF</b>	345	EMBANK 2-High Mobile Ped
<b>AMQCROHHD</b>	365	EMBANK Overhead
<b>AMQCROHOP</b>	365	EMBANK Overhead
<b>AMQCROHS</b>	366	EMBANK Stacking Overhead
<b>AMQCROHSDP</b>	365	EMBANK Overhead
<b>AMQCROHSHD</b>	366	EMBANK Stacking Overhead
<b>AMQCROHSSD</b>	366	EMBANK Stacking Overhead
<b>AMQCRORP</b>	367	EMBANK Personal Organizer
<b>AMQCRPD2HBBF</b>	344	EMBANK 2-High Fixed Ped
<b>AMQCRPD2HFF</b>	344	EMBANK 2-High Fixed Ped
<b>AMQCRPWKSF</b>	358	EMBANK P-Shaped WS
<b>AMQCRRECTBL</b>	370	EMBANK Rect Table
<b>AMQCRRTBL</b>	369	EMBANK Round Table
<b>AMQCRRTNL</b>	356	EMBANK Return Shell
<b>AMQCRRTNR</b>	356	EMBANK Return Shell
<b>AMQCRRTNSPL</b>	356	EMBANK Return
<b>AMQCRRTNSPR</b>	356	EMBANK Return
<b>AMQCRSQB</b>	375	EMBANK Square leg
<b>AMQCRSQTB</b>	369	EMBANK Square Table
<b>AMQCRTB</b>	368	EMBANK Fabric Tackboard
<b>AMQCRTWBFL</b>	359	EMBANK Tower
<b>AMQCRTWBFR</b>	359	EMBANK Tower
<b>AMQCRTWDBFL</b>	360	EMBANK Tower
<b>AMQCRTWDBFR</b>	360	EMBANK Tower
<b>AMQCRTWDFFL</b>	360	EMBANK Tower
<b>AMQCRTWDFFR</b>	360	EMBANK Tower
<b>AMQCRTWFFL</b>	359	EMBANK Tower
<b>AMQCRTWFFR</b>	359	EMBANK Tower
<b>AMQCRTWSABBFL</b>	361	EMBANK Tower
<b>AMQCRTWSABBFR</b>	361	EMBANK Tower
<b>AMQCRTWSAFFL</b>	361	EMBANK Tower
<b>AMQCRTWSAFFR</b>	361	EMBANK Tower
<b>AMQCRWDL</b>	362	EMBANK Wardrobe
<b>AMQCRWDR</b>	362	EMBANK Wardrobe
<b>AMQDSBULKSTRP</b>	164	WORK TOOLS Bulk Strap Pack
<b>AMQDSPINTRO</b>	163	WORK TOOLS Pwrstrp Intro
<b>AMQDSTRAYLG</b>	164	WORK TOOLS Cbl Mng Kit Lg
<b>AMQDSTRAYSM</b>	164	WORK TOOLS Cbl Mng Kit Sm
<b>AMQLOCK9201FR</b>	381	Lock Cylinder—FR Series
<b>AMQLOCK9201XF</b>	381	Lock Cylinder—XF Series
<b>AMQLSCTSKLIGHT1</b>	162	WORK TOOLS LED Intro Sgl
<b>AMQLSCTSKLIGHT2</b>	162	WORK TOOLS LED Intro Dbl
<b>AMQPCDB1</b>	165	WORK TOOLS SOTO Intro Bndl
<b>AMQPCDB3</b>	165	WORK TOOLS SOTO Box Bndl
<b>AMQRCHE2430</b>	349	EMBANK Cushion
<b>AMQRCHE2436</b>	349	EMBANK Cushion
<b>AMQRMBB</b>	276	TEKTIS Markerboard
<b>AMQRPXDPT</b>	275	TEKTIS Pencil Tray

Style Number	Page	Description	Style Number	Page	Description
<b>AMQRXADRL15</b>	275	TEKTIS Rail	<b>AMQWESARYLNG1</b>	483	Brighton One Seat Lounge
<b>AMQTKBSTE</b>	250	Vertical End-of-Run Stacker End Cap	<b>AMQWESARYLNG2</b>	484	Brighton Two Seat Lounge
<b>AMQTKBSTMC</b>	251	Middle-of-Run Boundary Scrn Top Cap	<b>AMQWESARYO</b>	485	Brighton Ottoman
<b>AMQTS2CW</b>	274	Counterweight - Tektis, Pedestal	<b>AMQWESARYPWR</b>	491	Brighton Power Module
<b>AMQTS2FILLER</b>	274	TEKTIS Ped Filler	<b>AMQWESARYTBL90</b>	486	Brighton 90° Ganging Table
<b>AMQTS2INT</b>	274	Tektis Interlock	<b>AMQWESARYTBLED</b>	488	Brighton End Table
<b>AMQTS2PBBFU</b>	256	TEKTIS Fixed Ped	<b>AMQWESARYTBLRT</b>	490	Brighton Rect Table
<b>AMQTS2PFFU</b>	256	TEKTIS Fixed Ped	<b>AMQWESARYTBLSG</b>	487	Brighton Straight Ganging Tbl
<b>AMQTS7BSWHC</b>	259	TEKTIS Wall Channels	<b>AMQWESARYTBLSQ</b>	489	Bright Square Table
<b>AMQTSAE986694B</b>	264	BASE POWER IN 4 CIRCUIT	<b>AMQWESINDMP</b>	411	Greenpoint Modesty Panel
<b>AMQTSAE986694SFB</b>	264	POWER IN-BASE,4 CKT SF	<b>AMQWESINDPD</b>	410	Greenpoint Private Desk
<b>AMQTSAE98669B</b>	264	TEKTIS Base Power-In	<b>AMQWESINDRL</b>	411	Greenpoint Dsk Rtn w/ Leg
<b>AMQTSAE98669SFB</b>	264	TEKTIS Base Power-In	<b>AMQWESLUCS</b>	499	Lucas Swivel Chair
<b>AMQTSADASB</b>	261	Duplex Recp, 15-Amp - 4-Circuit 6pk	<b>AMQWESLUCW</b>	499	Lucas Wire Chair
<b>AMQTSAEGROM</b>	265	TEKTIS Grommet Package	<b>AMQWESMDC4NA</b>	496	Sterling 4-Leg Armless Guest Chair
<b>AMQTSAP3B</b>	262	TEKTIS 3-Circuit Power Pole	<b>AMQWESMDC4WA</b>	496	Sterling 4-Leg with Arms Guest Chair
<b>AMQTSAP4B</b>	262	POLE POWER 4 CIRCUIT	<b>AMQWESMDC5NA</b>	497	Sterling 5-Star Armless Conference Ch
<b>AMQTSAP3C</b>	263	TEKTIS Cable Pole	<b>AMQWESMDC5WA</b>	498	Sterling 5-Star with Arms Conf Ch
<b>AMQTSAP4B</b>	261	TEKTIS 15-Amp Receptacle	<b>AMQWESMDCSBHNA</b>	497	Sterling Bar Height Armless Stool
<b>AMQTSAPB120</b>	252	TEKTIS 120° Connector	<b>AMQWESMES2SEAT</b>	493	Mesa Armless Lounge
<b>AMQTSAPBCOH</b>	252	TEKTIS Connector Pkg	<b>AMQWESMESC</b>	493	Mesa Corner Lounge
<b>AMQTSAPBWS66</b>	252	TEKTIS Wall Start Connector Pkg	<b>AMQWESMESCHLH</b>	492	Mesa LH Lounge
<b>AMQTSAPF</b>	241	TEKTIS Tack Acoustical Pnl	<b>AMQWESMESCHRH</b>	492	Mesa RH Lounge
<b>AMQTSAPS</b>	242	TEKTIS Tack Acoustical Pnl Strk	<b>AMQWESMESO</b>	494	Mesa Ottoman
<b>AMQTSAPSG</b>	244	TEKTIS Glass Pnl Strk	<b>AMQWESSLPCC</b>	501	Slope Height-Adjustable Conference Ch
<b>AMQTSAPTC</b>	247	TEKTIS Vert Corner Trim	<b>AMQWESSLPCG</b>	500	Slope Guest Chair
<b>AMQTSAPTCY</b>	248	TEKTIS 120° Vert Corner Trim	<b>AMQWESSLPCL</b>	500	Slope Lounge Chair
<b>AMQTSAPTE</b>	245	TEKTIS Vert End-of-Run Trim	<b>AMQWESSLPCS</b>	502	Slope Stacking Chair
<b>AMQTSAPTXC</b>	249	TEKTIS Vert Corner C-O-H Trim	<b>AMQWESSLPBB</b>	501	Slope Bar Height Stool
<b>AMQTSAPTXS</b>	246	TEKTIS Vert In-Line C-O-H Trim	<b>APS2</b>	68	ACTIV PRO 2.0 2 Stage Desk
<b>AMQTSASLCL</b>	258	TEKTIS Lam Common Shelf	<b>APS2B</b>	70	ACTIV PRO 2.0 2 Stage Base
<b>AMQTSASUBL</b>	257	TEKTIS Bin	<b>APS3</b>	69	ACTIV PRO 2.0 3 Stage Desk
<b>AMQTSATCANT</b>	254	TEKTIS Cantilever w/ Tie Plt	<b>APS3120</b>	74	ACTIV PRO 2.0 120 Degree Desk
<b>AMQTSATEP</b>	254	TEKTIS On-Mod End Pnl	<b>APS390</b>	72-73	ACTIV PRO 2.0 90° Desk with Return
<b>AMQTSATH</b>	254	TEKTIS H-Leg	<b>APS3B</b>	71	ACTIV PRO 2.0 3 Stage Base
<b>AMQTSATP27</b>	254	TEKTIS Post Leg	<b>APS3L3B</b>	75	ACTIV 2.0 3-leg Base
<b>AMQTSATPL</b>	377	EMBANK In-Line Support Plt	<b>APS3STRETCHER</b>	76	ACTIV 2.0 Extended Stretcher Bar
<b>AMQTSATRC</b>	377	EMBANK Reinforcing Channel	<b>BODICHAIR</b>	445	BODI Task Chair
<b>AMQTSATSIDE</b>	255	TEKTIS Side Support Bracket	<b>BODISEATCOVER</b>	446	BODI Seat Cover
<b>AMQTSATTIE</b>	377	EMBANK Tie Plates	<b>BOOSTPOWER</b>	159	Boost Power Box
<b>AMQTSAWLCC</b>	269	TEKTIS Curved Corner WS	<b>BRNL4PK</b>	459	Armless 4-Leg Chair 4 Pck
<b>AMQTSAWLCF</b>	268	TEKTIS Straight Corner WS	<b>BRNW4PK</b>	459	Armless Wire Base Chair 4 Pck
<b>AMQTSAWLEL</b>	270	TEKTIS LH Ext Curved Corner WS	<b>CLCASTERS</b>	88	CLUVO Casters
<b>AMQTSAWLER</b>	271	TEKTIS RH Ext Curved Corner WS	<b>CLCBASKET</b>	88	CLUVO Cable Basket
<b>AMQTSAWLR</b>	267	TEKTIS Straight WS	<b>CLS2</b>	86	CLUVO 2 Stage Desk
<b>AMQTSAWLT</b>	273	TEKTIS Transaction Worksurface	<b>CLS2B</b>	87	CLUVO 2 Stage Base
<b>AMQTSAWLY</b>	272	TEKTIS 120° Corner WS	<b>CLS3</b>	86	CLUVO 3 Stage Desk
<b>AMQTSHB</b>	260	TEKTIS Wall Channel Horizontal Brace	<b>CLS3B</b>	87	CLUVO 3 Stage Base
<b>AMQUCANT</b>	255	Tektis - On-Module Cantilever	<b>CNCRFRAME</b>	93	CONCUR Frame
<b>AMQWEM1</b>	502	Slope Guest Chair–Stocked	<b>CNCRMODESTY</b>	96	CONCUR Modesty Panel
<b>AMQWEM2</b>	503	Slope Lounge Chair–Stocked	<b>CNCRTABLE</b>	92	CONCUR Table
<b>AMQWEM3</b>	504	Slope Conference Chair–Stocked	<b>CNCRIZUBNDL</b>	94	CONCUR TIZU Seating bundle
<b>AMQWEM66</b>	503	Slope Bar Stool–Stocked	<b>CNCRWORKSURFACE</b>	96	CONCUR Worksurface
<b>AMQWEM70</b>	495	Nimbus Conf Chair	<b>CONCUR-EE-CB</b>	95	CONCUR Power Base In-Feed
<b>AMQWEM8</b>	413	Linear Personal Table	<b>CONCUR-EE-CNT</b>	95	60" Power Link

Style Number Index, continued

Style Number	Page	Description
<b>CONCUR-EE-JMP</b>	95	24" Power Jumper
<b>CONCUR-GK</b>	96	CONCUR Ganging Kit
<b>EMCAFERDTBL</b>	371	Café-Height Round
<b>EMCAFESQTBL</b>	371	Café Height Square
<b>EMLKD2</b>	400	Locker - Double Wide, 2 Door
<b>EMLKD4</b>	401	Locker - Double Wide, 4 Door
<b>EMLKD6</b>	402	Locker - Double Wide, 6 Door
<b>EMLKD8</b>	402	Locker - Double Wide, 8 Door
<b>EMLKMKEY</b>	404	Manager Key
<b>EMLKPKEY</b>	404	Programming Key
<b>EMLKS1</b>	397	Locker - Single Wide, 1 Door
<b>EMLKS2</b>	398	Locker - Single Wide, 2 Door
<b>EMLKS3</b>	399	Locker - Single Wide, 3 Door
<b>EMLKS4</b>	399	Locker - Single Wide, 4 Door
<b>EMLKSHFD</b>	403	Shelf - Adjustable, Double Wide Locker
<b>EMLKSHFS</b>	403	Shelf - Adjustable, Single Wide Locker
<b>EMWPOWER</b>	374	Single Unit Power Module
<b>EMWRDTBL</b>	372	Working-Height Round
<b>EMWRSQTBL</b>	373	Working-Height Square
<b>FLXXBACKCOVER</b>	450	FL-X Chair, Fabric Back Cover
<b>FLXXCHAIR</b>	449	FL-X Chair
<b>FLXXSEATCOVER</b>	450	FL-X Chair, Fabric Seat Cover
<b>ILNEBASE</b>	48	ILINE Base Kit
<b>ILNEBEAM</b>	46	ILINE Beam
<b>ILNECHIPWR</b>	53	ILINE Chicago Power Box
<b>ILNEPOST</b>	47	ILINE Post Kit
<b>ILNEPOWERPOLE</b>	50	ILINE Power Pole
<b>ILNEWIRETRAY</b>	160	ILINE Wire Tray
<b>JAKU001</b>	420	JAKU Pre-Configured Chair
<b>JAKU002</b>	420	JAKU Pre-Configured Chair
<b>JAKU003</b>	421	JAKU Pre-Configured Chair
<b>JAKU004</b>	421	JAKU Pre-Configured Chair
<b>JAKU005</b>	422	JAKU Pre-Configured Chair
<b>JAKU006</b>	422	JAKU Pre-Configured Chair
<b>JAKU007</b>	423	JAKU Pre-Configured Chair
<b>JAKU008</b>	423	JAKU Pre-Configured Chair
<b>JAKUCHAIR</b>	419	JAKU Task Chair
<b>JAKUSEATCOVER</b>	424	AMQ JAKU Seat Cover
<b>KINXBASE</b>	31	KINEX Base
<b>KINXBEAM</b>	34	Kinex- Beam
<b>KINXBENCH</b>	30	KINEX Bench
<b>KINXCHIPWR</b>	53	KINEX Chicago Power Box
<b>KINXCROSSBEAM</b>	34	Kinex- Cross Beam
<b>KINXDBLJUNCTIONBLK</b>	52	KINEX Double sided Jcnctn Block
<b>KINXENDPANEL</b>	33	KINEX End Panel
<b>KINXFEET</b>	34	KINEX Feet
<b>KINXPOWERPOLE</b>	50	KINEX Power Pole
<b>KINXSGLJUNCTIONBLK</b>	52	KINEX Single sided Jcnctn Block
<b>KINXWORKSURFACE</b>	32	KINEX Worksurface
<b>MONITORARM</b>	161	Single Monitor Arm
<b>PPCHAIR</b>	439	PERSONALITY PLUS Chair
<b>PPHEADREST</b>	441	PERSONALITY PLUS Headrest
<b>PPSTOOL</b>	440	PERSONALITY PLUS Stool
<b>PWRCRECEPTACLE</b>	54	Power C Receptacle for KINEX
<b>PWRENTRY</b>	51	Power Entry

Style Number	Page	Description
<b>PWRGRECEPTACLE</b>	54	ILINE Power G-Receptacle
<b>PWRJUMPER</b>	55	Power Adj Jumper Adapter
<b>PWRJUNCTIONBLK</b>	53	ILINE Double Sided Jcnctn Block
<b>REVI-BH</b>	127	REVI Bag Hook
<b>REVI-FP</b>	127	REVI File Pocket
<b>REVI-PNCLTRY</b>	126	REVI Pencil Tray
<b>REVICUSHION</b>	126	REVI Cushion
<b>REVILAPTOPSHELF</b>	127	REVI Laptop Shelf
<b>REVIPEDESTAL</b>	124	REVI Pedestal
<b>REVISHELF</b>	126	REVI Undermount Shelf
<b>REVIUNDERMOUNT</b>	125	REVI Undermount
<b>SS-CRK</b>	137	S Series Core Removal Key
<b>SS-LCK</b>	137	S Series Lock Core and Keys
<b>SS-MK</b>	138	S Series Master Key
<b>SSFL2H</b>	135	S-SERIES 2-High Lateral File
<b>SSFP2H</b>	134	SERIES 2-High Pedestal
<b>SSLATCUSH</b>	137	S-Series Enhanced Lateral Cushion
<b>SSPEDCUSH</b>	136	S-Series Enhanced Pedestal Cushion
<b>SSRSPEDESTAL</b>	134	S-SERIES Storage Pedestal
<b>SSRSSORAGE</b>	135	S-SERIES Storage, 1.5 H
<b>SSWTF</b>	136	S-SERIES Tower
<b>SWALLBH</b>	169	Binder Holder
<b>SWALLCUP</b>	171	Pen/Pencil Cup
<b>SWALLDISH</b>	171	Double Square Dish
<b>SWALLFS</b>	166	Freestanding Slatwall Stanchions
<b>SWALLHB</b>	171	Hanging Brackets
<b>SWALLHOOK</b>	173	Coat Hook
<b>SWALLOF</b>	172	Office in a File
<b>SWALLPF</b>	170	PaperFlo Manager
<b>SWALLPM</b>	168	Panel-Mount Brackets
<b>SWALLPM42</b>	168	Panel-Mount Brac for 42H Tektis Panel
<b>SWALLPS</b>	172	Personal Shelf
<b>SWALLTACK</b>	173	Tackstrip
<b>SWALLTC</b>	172	Telephone Caddy
<b>SWALLTILE</b>	167	Slatwall Tiles
<b>SWALLTRAY</b>	169	Trays
<b>SWALLUS</b>	170	Universal Shelves, Single Pack
<b>SWALLUS3</b>	170	Universal Shelves, Three Pack
<b>SWALLWB</b>	173	Wastebasket
<b>SWALLWM</b>	168	Wall-Mount Brackets
<b>TIZU-GLD</b>	456	AMQ TIZU Glides, Set of 4
<b>TIZUNEST</b>	455	TIZU Nesting Chair Multipurpose
<b>TIZUSEATCOVER</b>	456	TIZU Seat Cover
<b>TIZUWORK</b>	454	TIZU Task Chair
<b>TKBSSPNE</b>	278	TEKTIS End-of-Run Screen, Spanning
<b>TKBSSPNEL</b>	283	TEKTIS L End-of-Run Screen, Spanning
<b>TKBSSPNM</b>	281	TEKTIS Mid-of-Run Screen, Spanning
<b>TKBSSPNML</b>	285	TEKTIS L Mid-of-Run Screen, Spanning
<b>TKBSSPTE</b>	279	TEKTIS End-of-Run Screen, Split
<b>TKBSSPTEL</b>	283	TEKTIS L End-of-Run Screen, Split
<b>TKBSSPTM</b>	281	TEKTIS Middle-of-Run Screen, Split
<b>TKBSSPTML</b>	285	TEKTIS L Middle-of-Run Screen, Split
<b>TKBSSSE</b>	278	TEKTIS End-of-Run Screen, Sgl-Sided
<b>TKBSSSEL</b>	282	TEKTIS L End-of-Run Screen, Sgl-Sided
<b>TKBSSSM</b>	280	TEKTIS Mid-of-Run Screen, Sgl-Sided

Style Number	Page	Description
<b>TKBSSML</b>	284	TEKTIS L Mid-of-Run Screen, Sgl-Sidd
<b>TKFGS</b>	243	Frameless Glass Stacker
<b>TKHMB</b>	286	TEKTIS Hanging Markerboard
<b>UBLIGHT17</b>	174	17" Stand Alone Light
<b>UBLIGHT31</b>	174	31" Stand Alone or Daisy Chain Str Lt
<b>UBLIGHT44</b>	174	44" Stand Alone or Daisy Chain Str Lt
<b>X-3F-SUSPENSION</b>	116	3F Hanging Pnl Ceil Susp
<b>X-3F-TAPE</b>	120	3F Wall Tile, Tape 1" x 36 yds
<b>X-E-PB4</b>	159	Eco Power Box 2 outlet
<b>X-E3-BF-CD72</b>	52	3-Cir Corded Pwr Entry Base
<b>X-E3-YC</b>	55	3-Circuit Y Connector
<b>X-E4-BF-CD72</b>	52	4-Cir Corded Pwr Entry Base
<b>X-FCMT</b>	159	ACTIV Soft Cable Management
<b>ZILO001</b>	428	ZILO Pre-Configured Chair
<b>ZILO002</b>	429	ZILO Pre-Configured Chair
<b>ZILO003</b>	430	ZILO Pre-Configured Chair
<b>ZILO004</b>	431	ZILO Pre-Configured Chair
<b>ZILO005</b>	432	ZILO Pre-Configured Chair
<b>ZILO006</b>	433	ZILO Pre-Configured Chair
<b>ZILO007</b>	434	ZILO Pre-Configured Chair
<b>ZILO008</b>	435	ZILO Pre-Configured Chair
<b>ZILOCHAIR</b>	427	ZILO Task Chair
<b>ZILOSEATCOVER</b>	436	ZILO Seat Cover