Seating

Volume 2a

Terms and Conditions	2
Sample Order Form	10
Participating Steelcase Dealers	12
Steelcase Showrooms and Manufacturing Locations	17

Product Information	
Steelcase Seating (SIN 711.18/711.19)	19
turnstone 1.0 Seating (SIN 711.18)	487

Resources	501
Style Number Index	502

► For a list of all trademarks, refer to the last page of this specification guide.

Terms and Conditions

Customer Information

For more information, please contact your participating Steelcase GSA dealer.

For more information, please contact your participating Steelcase GSA dealer.

For more information, please contact your participating Steelcase GSA dealer.

For more information, please contact your participating Steelcase GSA dealer.

For more information, please contact your participating Steelcase GSA dealer.

For more information, please contact your participating Steelcase GSA dealer.

For more information, please contact your participating Steelcase GSA dealer.

For more information, please contact your participating Steelcase GSA dealer.

Sample Order Form

Sample Order Form

ORDER FOR SUPPLIES OR SERVICES			PAGE	OF	PAGES
IMPORTANT: Mark all packages and papers with contract and/or order numbers.					
DATE OF ORDER 1 6-1-04	CONTRACT NO. (If any) 2 GS-27F-0014V	ORDER NO. 3 10 - 000	REQUISITION/REFERENCE NO.		
ISSUING OFFICE (Address correspondence to) 4 GSA 1 Town Street City, State, Zip Name and Telephone Number		SHIP TO: (Consignee and address, ZIP Code) 5 GSA 2 Town Street City, State, Zip Name and Telephone Number			
TO: CONTRACTOR (Name, address and ZIP Code) 6 Steelcase Inc. c/o Participating Dealer 901 44th Street, SE Grand Rapids, MI 49508 Attn: Solutions Fullfillment Team CH-2W-SS (GSA)		Cage Code: 39880		TYPE OF ORDER <input type="checkbox"/> A. PURCHASE — Reference your _____ Please furnish the following on the terms and conditions specified on both sides of this order and on the attached sheets, if any, including delivery as indicated. This purchase is negotiated under authority of: <input type="checkbox"/> B. DELIVERY — Except for billing instructions on the reverse, this delivery order is subject to instructions contained on this side only of this form and is issued subject to the terms and conditions of the above-numbered contract.	
ACCOUNTING AND APPROPRIATION DATA			REQUISITIONING OFFICE		
			BUSINESS CLASSIFICATION (Check appropriate box(es)) 20 <input type="checkbox"/> SMALL <input checked="" type="checkbox"/> OTHER THAN SMALL <input type="checkbox"/> DIS-ADVANTAGED <input type="checkbox"/> WOMEN-OWNED		
FCA DESTINATION 7		GOVERNMENT NO.	DELIVER TO FCA DESTINATION ON OR BEFORE (Date) 8 ARO date	DISCOUNT TERMS 9 Net 30 days	
PLACE OF INSPECTION AND ACCEPTANCE					

(See reverse for Rejections)

ITEM NO. (A)	SUPPLIES OR SERVICES (B)	QUANTITY ORDERED (C)	UNIT (D)	UNIT PRICE (E)	AMOUNT (F)	QUANTITY ACCEPTED (G)	
1	10 One lot of Steelcase Office Furniture: See attached specifications	13 1		14 \$000	15 \$000		
2	11 Design: \$55.41/hour	2	hrs	\$000	\$000		
3	12 Installation	1		\$000	\$000		
SEE BILLING INSTRUCTIONS ON REVERSE		SHIPPING POINT		GROSS SHIPPING WEIGHT		INVOICE NO.	
		MAIL INVOICE TO: (Include ZIP Code) 17 GSA, 3 Town Street, City, State, Zip				16 \$000	(H) TOT. (Cont. pages) ◀ (I) GRAND TOTAL ◀
UNITED STATES OF AMERICA BY (Signature) 18 Contracting Officer signature and telephone no.				NAME (Typed) 19 John Doe, Department Manager TITLE: CONTRACTING/ORDERING OFFICER			

NSN 7540_01_152_8083

50347-101

OPTIONAL FORM 347 (10-83)
Prescribed by GSA
FAR (48 CFR) 53.213 (e)

- 1 Order date
- 2 Contract number
- 3 Order number
- 4 Issuing office: Requester name and telephone number
- 5 Shipping address: Contact name and telephone number
- 6 Contractor:
Steelcase Inc.
c/o Participating Dealer
901 - 44th Street, S.E.
Grand Rapids, MI 49508
Attn: Solutions Fulfillment Team
- 7 FCA destination
- 8 ARO date (After Receipt of Order)
- 9 Terms: Net 30 days
- 10 Complete product description, including SIN number, style number, all applicable surface materials.
- 11 Separate line for design
- 12 Separate line for installation
- 13 Quantity ordered
- 14 Individual unit price
- 15 Amount (quantity x unit price)
- 16 Total cost
- 17 Invoice address
- 18 Authorized contracting officer signature and telephone number
- 19 Authorized contracting officer name and title (typed)
- 20 Steelcase is the seller of record and is not registered as "small," "disadvantaged," or "woman-owned." If one of these boxes is checked in error, a modification will be required.

Please note on order that all invoice payments must be sent to:

Steelcase Inc.
62087 Collection Center Dr.
Chicago, IL 60693-0620

Storage and Delays

(Open Market) In the event that the site is not accessible, or safe and adequate storage space is not available during installation, the furnishings will be stored until delivery or installation can be accomplished. Pricing for storage will be negotiated on a project-by-project basis. Invoices will be sent to the local government purchasing facility upon delivery of the furniture to a designated storage facility. Steelcase shall provide notice to the Government purchasing facility that the furnishings are available for inspection by the Government at the Storage facility. Upon this notice, the Government, or representative for the Government, must inspect and accept the furniture prior to payment of any invoice. The inspection and acceptance must be completed within reasonable time frame agreed upon by both parties. Payment will be made by the Government 30 days after acceptance of the furniture.

Participating Steelcase Dealers

Alabama

Dekalb Office of Alabama
2901 Second Ave South
Birmingham, AL 35233
Phone: (205) 933-9100

Kyser OfficeWorks Inc.
2400 Spruce Street
Montgomery, AL 36107-3150
Phone: (334) 834-9400
Fax: (334) 262-0701

OEC Business Interiors
104 East I-65 Service Road North
Mobile, AL 36607-2501
Phone: (251) 471-3368
Fax: (251) 471-0019

Office Interiors by OSCO
1300 Meridian Street
Suite 203
Huntsville, AL 35801
Phone: (256) 604-5696
Fax: (256) 604-5699

OSCO Inc.
229 Grant Street SE
Decatur, AL 35601-2511
Phone: (256) 340-5100
Fax: (256) 340-5108

Alaska

Capital Office Systems
1120 East 35th Avenue
Anchorage, AK 99508-4257
Phone: (907) 777-1500
Fax: (907) 777-1515

Capital Office Systems
3201 Industrial Avenue
Fairbanks, AK 99701-7370
Phone: (907) 456-3946
Fax: (907) 452-6257

Capital Office Systems
3143 Channel Drive
Juneau, AK 99801-7214
Phone: (907) 780-3636
Fax: (907) 780-2290

Arizona

Atmosphere Commercial Interiors
815 North Central Avenue
Phoenix, AZ 85004
Phone: (602) 252-6971

Atmosphere Commercial Interiors
Suite 100
88 East Broadway Boulevard
Tucson, Arizona 85701-1720
Phone: (520) 792-4200

Atmosphere Commercial Interiors
Suite 100
88 East Broadway Boulevard
Tucson, Arizona 85701-1720
Phone: (520) 792-4200
Fax: (540) 791-9568

Arkansas

ImageWorks
Suite B
1424 North Shackelford
Little Rock, AR 72211
Phone: (501) 944-7501

Today's Office Inc.
717 West 7th Street
Little Rock, AR 72201-4044
Phone: (501) 375-5050
Fax: (501) 375-1350

Today's Office Inc.
3157 West Sunset Avenue
Springdale, AR 72762-4945
Phone: (479) 751-5861
Fax: (479) 756-2233

California

BKM Office Environments
816 Via Alondra
Camarillo, CA 93012
Phone: (877) 256-1256
Fax: (805) 339-9032

BKM San Diego
Suite 100
9201 Spectrum Center Blvd.
San Diego, CA 92123-1407
Phone: (858) 569-4700
Fax: (858) 277-8931

One Workplace L. Ferrari
2500 De La Cruz Blvd.
Santa Clara, CA 95050
Phone: (669) 800-2500
Fax: (669) 800-2501

One Workplace L. Ferrari
7220 Edgewater Drive
Oakland, CA 94621
Phone: (510) 729-7800
Fax: (510) 729-7801

One Workplace L. Ferrari
475 Brannan Street
San Francisco, CA 94107-1731
Phone: (415) 357-2200
Fax: (415) 357-2201

Peninsula Business Interiors
325 Main Street
Salinas, CA 93901-2705
Phone: (831) 757-4107
Fax: (831) 757-1339

Tangram Interiors
Suite 102
4057 W Shaw Ave
Fresno, CA 93722-6212
Phone: (559) 275-7070
Fax: (559) 275-7080

Tangram Interiors
Suite 100
2850 South Red Hill Avenue
Santa Ana, CA 92705-5532
Phone: (949) 955-6700
Fax: (949) 955-6799

Tangram Interiors
9200 Sorensen Avenue
Santa Fe Springs, CA 90670-2645
Phone: (562) 365-5000
Fax: (562) 365-5399

United Corporate Furnishings
1780 North Market Blvd.
Sacramento, CA 95834-1997
Phone: (916) 553-5900
Fax: (916) 553-5800

Colorado

Office Outfitters & Planners Inc.
749 Main Street
Grand Junction, CO 81501-3535
Phone: (970) 245-6300
Fax: (970) 245-6301

OfficeScapes
2506 Zeppelin Rd
Colorado Springs, CO 80916
Phone: (719) 574-1113
Fax: (719) 574-1133

OfficeScapes
9900 East 51st Avenue
Denver, CO 80238-2430
Phone: (303) 574-1115
Fax: (303) 574-1116

OfficeScapes
Suite 180
4812 McMurry Avenue
Fort Collins, CO 80525-6222
Phone: (970) 223-5959
Fax: (970) 223-5858

Connecticut

Red Thread
300 East River Drive
East Hartford, CT 06108-4205
Phone: (860) 528-9981
Fax: (860) 528-1843

Red Thread
488 Wheelers Farm Rd.
Milford, CT 06461
Phone: (203) 874-7754
Fax: (203) 876-7915

Red Thread
700 Canal St 3rd Fl
Stamford, CT 06902
Phone: (860) 528-9981

Red Thread
40 Main Street
Torrington, CT 06790
Phone: (860) 482-2679
Fax: (860) 482-3590

Delaware

Corporate Interiors Inc.
223 Lisa Drive
New Castle, DE 19720-4193
Phone: (302) 323-9100
Fax: (302) 323-9251

Florida

American Business Interiors
215 Waverly Place
Melbourne, FL 32901-5444
Phone: (321) 723-5003
Fax: (321) 984-4221

Empire Office
Suite 140
2 Oakwood Boulevard
Hollywood, FL 33020
Phone: (954) 707-6200

Empire Office
South Florida
3201 Commerce Parkway
Miramar, FL 33025-3908
Phone: (954) 435-7300
Fax: (954) 435-7212

Empire Office
Suite 17
2315 Lynx Lane
Orlando, FL 32804
Phone: (407) 628-2400

Empire Office
5112 West Linebaugh Avenue
Tampa, FL 33624
Phone: (813) 418-3300

Empire Office
Suite 2
7830 Byron Drive
West Palm Beach, FL 33404-3332
Phone: (561) 840-8600
Fax: (561) 840-1873

Leitz & Reed Office Products
1119 Florida Avenue
Lynn Haven, FL 32444-4622
Phone: (850) 271-2600
Fax: (850) 271-0076

OEC Business Interiors
1601 NW 80th Boulevard
Gainesville, FL 32606-9140
Phone: (352) 332-1192
Fax: (352) 333-8002

· OEC Business Interiors
· 2393 SW College Road
· Ocala, FL 34474-1661
· Phone: (352) 620-2888
· Fax: (352) 620-2891

· OEC Business Interiors
· 6254 North W Street
· Pensacola, FL 32503-2746
· Phone: (850) 438-1100
· Fax: (850) 432-0003

· Office Furniture & Design Concepts
· 11866 Metro Parkway
· Ft. Myers, FL 33966-1307
· Phone: (239) 337-1212
· Fax: (239) 337-4910

· Perdue Office Interiors
· Suite 100
· 5 W Forsyth
· Jacksonville, FL 32256-7440
· Phone: (904) 737-5858
· Fax: (904) 737-6088

· Perdue Office Interiors
· Suite C7
· 1516 Capital Circle SE
· Tallahassee, FL 32301
· Phone: (850) 383-4225

Georgia

· Advent Business Interiors
· 1318 U.S. HWY 82 West
· Leesburg, GA 31721
· Phone: (229) 439-7418
· Fax: (229) 435-1279

· Advent Business Interiors
· 110 West Macon Park Dr.
· Macon, GA 31210
· Phone: (478) 471-0600

· DeKalb Office Environments
· 1320 Ridgeland Parkway
· Alpharetta, GA 30004-8442
· Phone: (770) 360-0200
· Fax: (770) 360-0305

· McWaters Inc.
· 3708 Benchmark Drive
· Augusta, GA 30907
· Phone: (706) 396-5400
· Fax: (706) 396-5401

· McWaters Inc.
· 117 Prosperity Drive
· Savannah, GA 31408-9551
· Phone: (912) 352-9000
· Fax: (912) 352-2034

Hawaii

· Interior Showplace Ltd.
· 956 Queen Street
· Honolulu, HI 96814-4118
· Phone: (808) 593-8420
· Fax: (808) 591-8324

Idaho

· Porter's Office Products
· 435 West Center Street
· Pocatello, ID 83204-3241
· Phone: (208) 232-1233
· Fax: (208) 232-8759

· Porter's Office Products
· 1050 North 2nd East
· Rexburg, ID 83440-5127
· Phone: (208) 356-4616
· Fax: (208) 356-8901

· Office Environment Company
· 623 South Americana Blvd.
· Boise, ID 83702-5120
· Phone: (208) 385-0507
· Fax: (208) 385-9392

Illinois

· A. Pomerantz
· Suite 940
· 222 Merchandise Mart Plaza
· Chicago, IL 60654-1223
· Phone: (312) 929-3335
· Fax: (312) 929-3311

· Atmosphere Commercial Interiors
· 801 North Perryville Road
· Rockford, IL 61107
· Phone: (815) 398-3300

· Egyptian Business Furniture
· 129 West Main Street
· Belleville, IL 62220-1501
· Phone: (618) 234-2323
· Fax: (618) 236-3295

· Interiors for Business Inc.
· 409 N River Street
· Batavia, IL 60510-2359
· Phone: (630) 761-1070
· Fax: (630) 761-1065

· Lincoln Office
· 205 Eastgate Drive
· Washington, IL 61571-9238
· Phone: (309) 427-2500
· Fax: (309) 427-2625

· Forward Space
· Suite 614
· 222 Merchandise Mart Plaza
· Chicago, IL 60654-1223
· Phone: (312) 563-5206

· Forward Space
· 1142 N North Branch Street
· Chicago, IL 60642
· Phone: (312) 942-1100
· Fax: (312) 942-9840

· Forward Space
· 13820 West Business Center Drive
· Lake Forest, IL 60045-1181
· Phone: (847) 573-8890
· Fax: (847) 573-8891

· Forward Space
· Suite 150
· 1111 West 22nd Street
· Oak Brook, IL 60523
· Phone: (312) 563-5206

Indiana

· Business Furnishings LLC
· 4102 Meghan Beeler Court
· South Bend, IN 46628
· Phone: (574) 243-3255
· Fax: (574) 243-3266

· Business Furniture LLC
· 6102 Victory Way
· Indianapolis, IN 46278-2934
· Phone: (317) 216-1600
· Fax: (317) 216-1601

· Corporate Design Inc.
· Suite 400
· 1419 West Lloyd Expressway
· Evansville, IN 47710-1002
· Phone: (812) 422-3000
· Fax: (812) 422-3413

· Lincoln Office
· 1200 Arrowhead Court
· Crown Point, IN 46307-8222
· Phone: (219) 662-2777
· Fax: (219) 662-7770

Iowa

· Lincoln Office
· 1026 Mound St
· Davenport, IA 52803
· Phone: (563) 322-5660

· Tallgrass Business Resources
· Highway 6 West
· 218 Second Street
· Coralville, IA 52241-2608
· Phone: (319) 338-3135
· Fax: (319) 338-7484

· Workspace Inc.
· 309 Locust Street
· Des Moines, IA 50309-1788
· Phone: (515) 288-7090
· Fax: (515) 288-0250

Kansas

· Design Central Inc.
· 152 South 5th Street
· Salina, KS 67401
· Phone: (785) 825-4131
· Fax: (785) 825-4778

· Scott Rice Office Interiors
· 224 East Douglas
· Wichita, KS 67211-1640
· Phone: (316) 269-2700
· Fax: (316) 269-3527

· Scott Rice Office Works
· 14720 West 105th Street
· Lenexa, KS 66215-4414
· Phone: (913) 888-7600
· Fax: (913) 227-7793

Kentucky

· Office Resources Inc.
· 530 Corvette Drive
· Bowling Green, KY 42101-7132
· Phone: (270) 781-5858
· Fax: (270) 781-5884

· Office Resources Inc.
· 101 Bradley Drive
· Nicholasville, KY 40356-9121
· Phone: (859) 885-6161
· Fax: (859) 885-9610

· Office Resources Inc.
· 816 East Broadway
· Louisville, KY 40204-1053
· Phone: (502) 589-8400
· Fax: (502) 589-8408

Louisiana

· Frost-Barber Inc.
· 9322 Interline Avenue
· Baton Rouge, LA 70809-1966
· Phone: (225) 926-5000
· Fax: (225) 926-5011

· Workplace Solutions
· 401 St. Joseph Street.
· New Orleans, LA 70130
· Phone: (504) 522-9558
· Fax: (504) 522-7070

Maine

· Red Thread
· One City Center
· Portland, ME 04101
· Phone: (207) 774-4900
· Fax: (207) 774-8155

Maryland

· Arbee Associates
· 6311 Ammendale Road
· Beltsville, MD 20705-1249
· Phone: (410) 385-5180
· Fax: (410) 385-5199

· Arbee Associates
· 9300 Gaither Road
· Gaithersburg, MD 20877
· Phone: (301) 963-3900
· Fax: (301) 977-1734

· Dancker, Sellow & Douglas Inc.
· Suite 309
· 509 Exeter Street
· Baltimore, MD 21202
· Phone: (301) 671-2541
· Fax: (301) 797-1504

Participating Steelcase Dealers, continued

Dancker, Sellaw & Douglas Inc.
9200 Alaking Court
Suite 100
Capitol Heights, MD 20743
Phone: (301) 350-8700
Fax: (301) 350-9393

Massachusetts

Red Thread
Suite 600
101 Seaport Blvd.
Boston, MA 02210-1838
Phone: (617) 439-4900
Fax: (617) 439-4131

Red Thread
Suite 150
293 Boston Post Road West
Marlborough, MA 01752-4615
Phone: (508) 449-6550
Fax: (508) 449-6570

Red Thread
Suite 1108
1350 Main Street
Springfield, MA 01103
Phone: (413) 736-1802

Red Thread
100 Fordham Road
Wilmington, MA 01887
Phone: (978) 658-3900
Fax: (978) 694-4107

Michigan

Custer Office Environments Inc.
2435 Plaza Drive
Benton Harbor, MI 49022-2229
Phone: (616) 926-8719
Fax: (616) 926-9482

Custer Office Environments Inc.
217 Grandville Ave SW
Grand Rapids, MI 49503-4013
Phone: (616) 458-6322
Fax: (616) 458-1117

Custer Office Environments Inc.
5737 East Cork Street
Kalamazoo, MI 49048-9668
Phone: (269) 342-3919
Fax: (269) 342-3923

Custer Office Environments
442 East Michigan
Marquette, MI 49885
Phone: (906) 226-1161
Fax: (906) 226-1164

Custer Office Environments
120 East Front Street
Traverse City, MI 49684
Phone: (616) 402-8489

NBS
701 Salzburg Avenue
Bay City, MI 48706-5390
Phone: (989) 895-8574
Fax: (989) 895-8545

NBS
5133 West Grand River Avenue
Lansing, MI 48906-9117
Phone: (517) 886-0072
Fax: (517) 886-0014

NBS
2595 Bellingham Drive
Troy, MI 48083-2036
Phone: (248) 823-5400
Fax: (248) 823-5401

Minnesota

Atmosphere Commercial Interiors
Suite 350
81 South 9th Street
Minneapolis, MN 55402-3226
Phone: (612) 343-0868
Fax: (612) 332-5733

Burgher Office Equipment Company
101 East Chestnut Street
Virginia, MN 55792-2512
Phone: (218) 749-2661
Fax: (218) 749-2662

Duluth Typewriter & Business Furniture
30 N 3rd. Ave W
Duluth, MN 55802-1607
Phone: (218) 722-5811
Fax: (218) 722-4876

General Office Products Company
4521 Highway 7
Minneapolis, MN 55416-4098
Phone: (952) 925-7500
Fax: (952) 925-7531

Mississippi

Workplace Solutions
251 West South Street
Jackson, MS 39203-3636
Phone: (601) 354-4960
Fax: (601) 353-6231

Workplace Solutions
2207 5th Street
Meridian, MS 38652
Phone: (601) 484-7279

Workplace Solutions
520 Main Street
Natchez, MS 39120
Phone: (601) 442-1494
Fax: (601) 442-0457

Workplace Solutions
718 West Bankhead St.
New Albany, MS 38652
Phone: (662) 534-0882
Fax: (662) 534-5753

OEC Business Interiors
12199 Highway 49 N.
Suite 300
Gulfport, MS 39503-3167
Phone: (228) 539-9575
Fax: (228) 539-9566

Missouri

Color-Art Integrated Interiors
1325 North Warson Road
Saint Louis, MO 63132-1807
Phone: (314) 432-3000
Fax: (314) 993-2752

Marathon Office Interiors
1715 Paris Road
Columbia, MO 65201-5571
Phone: (573) 875-7115
Fax: (573) 875-7116

Montana

KR Office Interiors
119 North 7th Avenue
Bozeman, MT 59715
Phone: (406) 587-3775
Fax: (406) 587-4636

KR Office Interiors
1710 North Montana Avenue
Helena, MT 59601
Phone: (406) 513-1004
Fax: (406) 513-1006

Missoula's Office City
115 West Broadway Street
Missoula, MT 59802-4217
Phone: (406) 543-7171
Fax: (406) 543-4254

Peterson's Quality Office Equipment
502 North 32nd Street
Billings, MT 59101-6003
Phone: (406) 245-5151
Fax: (406) 245-7516

Western Office Equipment
317 2nd Street South
Great Falls, MT 59405-1802
Phone: (406) 761-7473
Fax: (406) 761-0245

Nebraska

Eakes Office Plus
2911 13th Street
Columbus, NE 68601-4829
Phone: (402) 564-2679
Fax: (402) 564-0295

Eakes Office Plus
Suite 201
2630 North Yager Road
Fremont, NE 68025-7800
Phone: (402) 941-5001
Fax: (402) 941-5002

Eakes Office Plus
617 West Third Street
Grand Island, NE 68801-5946
Phone: (308) 382-8026
Fax: (308) 382-7401

Eakes Office Plus
839 West Second Street
Hastings, NE 68901-5099
Phone: (402) 463-2537
Fax: (402) 463-6802

Eakes Office Plus
2401 Avenue A
Kearney, NE 68847-5498
Phone: (308) 234-2538
Fax: (308) 234-2540

Eakes Office Plus
110 N 35th Street
Lincoln, NE 68503
Phone: (402) 438-6700
Fax: (402) 438-6701

Eakes Office Plus
1803 North 6th Street
Beatrice, NE 68310
Phone: (402) 228-7202
Fax: (402) 228-0262

Eakes Office Plus
120 Norris Avenue
McCook, NE 69001
Phone: (308) 345-5447
Fax: (308) 345-5237

Eakes Office Plus
510 W. 13th Street
Souix City, NE 68776
Phone: (402) 412-2334

Eakes Office Plus
201 South 1st Street
Norfolk, NE 68701-5303
Phone: (402) 371-4181
Fax: (402) 371-5139

Eakes Office Plus
520 North Vine Street
North Platte, NE 69101-3954
Phone: (308) 534-7800
Fax: (308) 534-3936

Eakes Office Plus
710 North Lincoln Ave.
York, NE 68467
Phone: (402) 362-5442
Fax: (402) 362-7530

Sheppard's Business Interiors Inc.
725 South 72nd Street
Omaha, NE 68114-4665
Phone: (402) 393-8888
Fax: (402) 393-0113

Nevada

Machabee Office Environments
6435 Sunset Corporate Drive
Las Vegas, NV 89120-2798
Phone: (702) 263-8800
Fax: (702) 263-8801

Machabee Office Environments
1335 Greg Parkway #101
Sparks, NV 89431
Phone: (775) 329-3145
Fax: (775) 786-5710

New Hampshire

Red Thread
Suite 103
650 Elm Street
Manchester, NH 03101-1160
Phone: (603) 668-5511
Fax: (603) 668-6851

New Jersey

Arbee Associates
1531 South Washington Avenue
Piscataway, NJ 08854-3815
Phone: (732) 424-3900
Fax: (732) 752-6034

Concepts Office Furnishings
280 North Midland Avenue
Building J
Saddle Brook, NJ 07663-5708
Phone: (201) 727-9110
Fax: (201) 727-9112

Dancker, Sellow, and Douglas
291 Evans Way
Somerville, NJ 08876-3766
Phone: (908) 231-1600
Fax: (908) 231-6469

W.S. Goff Company Inc.
5104 Oakland Blvd.
Mays Landing, NJ 08330-2016
Phone: (609) 625-5600
Fax: (609) 625-5633

New Mexico

Business Environments
5351 Wilshire Avenue, N.E.
Albuquerque, NM 87113-1834
Phone: (505) 888-4400
Fax: (505) 889-9146

New York

AFD Contract Furniture Inc
810 7th Avenue
New York, NY 10019
Phone: (212) 721-7100
Fax: (212) 721-7175

Merkel-Donohue
1 Interstate Avenue
Albany, NY 12205
Phone: (518) 273-9359
Fax: (518) 272-1552

Empire Office Inc.
105 Madison Avenue
New York, NY 10016-8810
Phone: (212) 607-5500
Fax: (212) 607-5654

Merkel-Donohue
1349 University Avenue Suite 2
Rochester, NY 14607
Phone: (585) 325-7696
Fax: (585) 325-3065

Prentice Office Environments
472 Franklin Street
Buffalo, NY 14202-1302
Phone: (716) 884-8452
Fax: (716) 884-0894

Stevens Office Interiors
6804 Manlius Center Road
East Syracuse, NY 13057-3902
Phone: (315) 479-5595
Fax: (315) 428-1688

Waldner's Business Environments
125 Route 110
Farmingdale, NY 11735-4864
Phone: (631) 844-9300
Fax: (631) 694-3503

Waldner's Business Environments
215 Lexington Avenue, 9th Floor
New York, NY 10016-6023
Phone: (212) 696-7500
Fax: (212) 696-7699

Waldner's Business Environments
411 Theodore Fremd Avenue
3rd Floor, South Building
Rye, NY 10580-1410
Phone: (914) 921-8500
Fax: (914) 921-0991

North Carolina

Office Environments Inc.
11407 Granite Street
Charlotte, NC 28273-6429
Phone: (704) 714-7200
Fax: (704) 714-7400

Young Office Environments
of Asheville Inc.
71 Thompson St
Asheville, NC 28803-2328
Phone: (888) 202-0508
Fax: (828) 505-1974

Storr Office Environments Inc.
496 Gallimore Dairy Road
Greensboro, NC 27409-9202
Phone: (336) 217-4500
Fax: (336) 217-4501

Storr Office Environments Inc.
10800 World Trade Blvd.
Raleigh, NC 27617-4200
Phone: (919) 313-3700
Fax: (919) 313-3701

Williams Office Environments Inc.
407 Ray Avenue
Fayetteville, NC 28301-4915
Phone: (910) 483-0354
Fax: (910) 486-4077

North Dakota

Fireside Office Products Inc.
1713 East Bismarck Expressway
Bismarck, ND 58504-6706
Phone: (701) 258-8586
Fax: (701) 223-9598

Hannaher's
1809 13th Avenue North
Grand Forks, ND 58203-2323
Phone: (701) 746-6466
Fax: (701) 746-0737

Hannaher's Inc.
4324 20th Avenue SW
Fargo, ND 58103-4434
Phone: (701) 277-7222
Fax: (701) 277-7097

Ohio

Business Furniture
8 North Main Street
Dayton, OH 45439
Phone: (937) 293-1010
Fax: (937) 293-7501

Loth Inc.
3574 East Kemper Road
Cincinnati, OH 45241-2009
Phone: (513) 554-4900
Fax: (513) 554-8737

Loth Company
855 Grandview Avenue
Columbus, OH 43215-1123
Phone: (614) 487-4000
Fax: (614) 487-4306

NBS
4 North St. Clair Street
Toledo, OH 43604
Phone: (419) 662-2040
Fax: (419) 662-2041

Ohio Desk
34 Swartz Road
Akron, OH 44319
Phone: (330) 499-1030

Ohio Desk
1122 Prospect Avenue
Cleveland, OH 44115-1292
Phone: (216) 623-0600
Fax: (216) 623-0611

Ohio Desk
5100 Market Street
Youngstown, OH 44512
Phone: (330) 782-3331

Oklahoma

Scott Rice
2900 North Hemlock Circle
Broken Arrow, OK 74012-1185
Phone: (918) 362-4300
Fax: (918) 362-4303

Scott Rice
7501 Broadway Ext
Oklahoma City, OK 73116-9015
Phone: (405) 848-2224
Fax: (405) 848-3999

Oregon

Hypfn
Suite 103/104
150 SW Scalehouse Loop
Bend, OR 97702
Phone: (541) 317-8777
Fax: (541) 317-2833

Hypfn
620 NE 19th Avenue
Portland, OR 97232-2832
Phone: (503) 226-4151
Fax: (503) 226-9233

Pennsylvania

A. Pomerantz & Company
Suite 7000
701 Market Street
Philadelphia, PA 19106-1597
Phone: (215) 408-2100
Fax: (215) 408-2110

Corporate Interiors
Suite 200
161 Washington Street
Conshohocken, PA 19428-2083
Phone: (610) 631-5400
Fax: (610) 631-2720

Interior Workplace Solutions LLC.
145 Stewart Road
Wilkes-Barre, PA 18706
Phone: (570) 288-7211
Fax: (570) 970-5817

Franklin Interiors
Suite 600
2740 Smallman Street
Pittsburgh, PA 15222-4720
Phone: (412) 261-2525
Fax: (412) 255-4089

Participating Steelcase Dealers, continued

Pennsylvania

Interior Workplace Solutions LLC.
6765 Ambassador Drive
Allentown, PA 18106-9510
Phone: (610) 391-0733
Fax: (610) 391-1155

Interior Workplace Solutions LLC.
Suite B-25
2209 Quarry Drive
Reading, PA 19609-1155
Phone: (610) 670-1800
Fax: (610) 670-8181

McCartney's Inc.
819 Howard Avenue
Altoona, PA 16601-4727
Phone: (814) 505-1111
Fax: (814) 949-6197

Phillips Workplace Interiors
6345 Flank Drive
Harrisburg, PA 17112
Phone: (844) 228-2600

South Carolina

Aiken Office Supply Inc.
2560 Whiskey Road
Aiken, SC 29803-9664
Phone: (803) 648-8339
Fax: (803) 649-4470

McWaters Inc.
1104 Shop Road
Columbia, SC 29201-4743
Phone: (803) 256-8303
Fax: (803) 252-5567

McWaters Inc.
3841 Commercial Center Drive
Ladson, SC 29456-4146
Phone: (843) 486-1823

Wulbern-Koval Company Inc.
1111 Morrison Drive
Charleston, SC 29403-3119
Phone: (843) 577-7666
Fax: (843) 577-7299

Young Office Environments
1280 Ridge Road
Greenville, SC 29607-4626
Phone: (864) 281-9500
Fax: (864) 281-9555

South Dakota

Interstate Office Products Inc.
228 South Main Avenue
Sioux Falls, SD 57104-6310
Phone: (605) 339-0300
Fax: (605) 339-1989

Western Stationers
714 Saint Joseph Street
Rapid City, SD 57701-2721
Phone: (605) 342-3310
Fax: (605) 342-4746

Tennessee

Bentco Office Solutions
1501 Stuart Street
Chattanooga, TN 37406
Phone: (423) 756-4437
Fax: (423) 756-6198

Memphis Business Interiors
4539 West Distriplex Drive
Memphis, TN 38118-7280
Phone: (901) 360-8899
Fax: (901) 360-8370

Office Resources Inc.
4020 Armory Oaks Drive
Nashville, TN 37204
Phone: (615) 376-1200
Fax: (615) 376-1245

Workspace Interiors
Suite 300
200 E. Main Street
Kingsport, TN 37660-4354
Phone: (423) 392-2600
Fax: (423) 392-2601

Workspace Interiors
2820 Middlebrook Pike
Knoxville, TN 39721
Phone: (865) 223-5404
Fax: (865) 223-5405

Texas

Abilene Printing & Stationery
218 Cedar Street
Abilene, TX 79601-5720
Phone: (915) 677-2673
Fax: (915) 675-6963

BKM Total Office of Texas
9755 Clifford Drive
Dallas, TX 75220
Phone: (214) 902-7200
Fax: (214) 902-7201

Business Interiors
1111 Valley View Lane
Irving, TX 75061-6008
Phone: (817) 858-2000
Fax: (817) 858-2020

McCoys Inc.
6869 Old Katy Road
Houston, TX 77024-2105
Phone: (713) 862-4600
Fax: (713) 862-7676

Rockford Business Interiors
211 East Riverside Drive
Austin, TX 78704-1203
Phone: (512) 442-0703
Fax: (512) 442-6555

Texas Wilson Office Furniture & Services
5801 George McVay Drive
McAllen, Texas 78503
Phone: (210) 647-8800
Fax: (210) 647-3110

Texas Wilson Office Furniture & Services

6812 Fairgrounds Pkwy
San Antonio, TX 78238-4536
Phone: (210) 647-8800
Fax: (210) 647-3110

West Supply Company
1601 Scurry
Big Spring, TX 79720
Phone: (432) 264-1788
Fax: (432) 264-1789

West Supply Company
2 South Chadbourne Street
San Angelo, TX 76903-5875
Phone: (325) 655-8181
Fax: (325) 655-5480

Utah

MidWest Office Furniture
987 South West Temple
Salt Lake City, UT 84101-2988
Phone: (801) 359-7681
Fax: (801) 355-2713

Vermont

Red Thread
180 Battery St Ste 210
Burlington, VT 05401-5212
Phone: (802) 862-0434
Fax: (802) 862-0729

Virginia

Barrows
1302 Rockland Avenue
Roanoke, VA 24012-3838
Phone: (540) 362-5700
Fax: (540) 362-4826

Creative Office Environments
11798 North Lakeridge Boulevard
Ashland, VA 23005-8152
Phone: (804) 329-0400
Fax: (804) 321-3134

Creative Office Environments LLC
650 Peter Jefferson Parkway #140
Charlottesville, VA 22911
Phone: (434) 327-1898
Fax: (434) 327-1896

Creative Office Environments LLC
Suite C
500 Woodlake Circle
Chesapeake, VA 23320-2807
Phone: (757) 549-4801
Fax: (757) 549-2795

reDistrict
Suite 30
66 Canal Center Plaza
Arlington, VA 22314
Phone: (703) 276-8901
Fax: (703) 276-8908

Washington

OpenSquare
6th Floor
5601 Sixth Avenue South
Seattle, WA 98108-2522
Phone: (206) 768-8000
Fax: (206) 768-0236

OpenSquare
126 South Sheridan Street
Spokane, WA 99202-1527
Phone: (509) 483-1000
Fax: (509) 483-1011

Wisconsin

Atmosphere Commercial Interiors
999 Fourier Drive Suite 200
Madison, WI 53717
Phone: (608) 257-0521
Fax: (608) 257-1859

Puerto Rico

AFD Contract Furnishings
Suite 250
350 Chardon Avenue
Torre Chardon
San Juan, Puerto Rico 00918-2123
Phone: (787) 754-2938
Fax: (787) 754-8076

Showrooms

Atlanta

Steelcase Inc.
Suite AL-175
303 Peachtree Center
Atlanta, GA 30303
Phone: (404) 523-2201

Chicago

Steelcase Worklife Chicago
Suite 300
222 Merchandise Mart
Chicago, IL 60654-1174
Phone: (312) 321-3720

Chicago

Coalesse
Suite 1032
222 Merchandise Mart
Chicago, IL 60654
Phone: (312) 467-1783

Dallas

Steelcase Inc.
1616 Hi Line Drive
Dallas, TX 75207
Phone: (214) 871-3044

Grand Rapids

Steelcase Inc.
901 44th Street, SE
Grand Rapids, MI 49508-7594
Phone: (616) 247-2710

New York

Steelcase Worklife New York
4 Columbus Circle
New York, NY 10019-1100
Phone: (212) 445-8800

Philadelphia

Steelcase Inc.
One Liberty Place
1650 Market Street, 3rd Floor
Philadelphia, PA 19103-7307
Phone: (215) 561-5331

San Francisco

Steelcase Inc.
Suite 110
475 Brannan Street
San Francisco, CA 94107
Phone: (415) 344-6700

Santa Monica

Steelcase Inc.
1217 2nd Street
Santa Monica, CA 90401-1180
Phone: (310) 633-2200

Washington D.C.

Steelcase Inc.
1121 14th Street NW
4th Floor
Washington, DC 20005

Manufacturing Sites

Amex de Mexico

Calle 5 Sur No.160
Ciudad Industrial
Tijuana, Mexico B.C. 22500
Phone: 52-662-342-6234

Athens

214 Durham Drive
Athens, AL 35611
Phone: (256) 232-8112

Grand Rapids Wood Furniture

4100 68th Street SE
Caledonia, MI 49316
Phone: (616) 698-5735

Kentwood Distribution Center

4384 52nd Street SE
Kentwood, MI 49512-9673

Kentwood West

4360 52nd Street SE
Kentwood, MI 49512

Details

901 44th Street SE
Grand Rapids, MI 49508
Phone: (616) 247-2710

Reynosa Plant

Ave. Prologis S/N Ed. 8 Suite
801 Prologis Park Pharr Bridge
Reynosa,
Tamaulipas, Mx CP. 88780
Phone: 52-899-263-9000



Steelcase Seating



Statement of Line 20

Product Information

Work Chairs

Gesture 442 Series (SIN 711.18)	30
Leap 462 Series (SIN 711.18)	44
Siento 499 Series (SIN 711.18)	68
Criterion 453 Series (SIN 711.18)	76
Think 465 Series (SIN 711.18)	100
Steelcase Series 1 (711.18)	114
Amia 482 Series (SIN 711.18)	124
Reply 466 Series (SIN 711.18)	152
Jersey Series (SIN 711.18)	170
Protégé 433 Series (SIN 711.18)	182
Cachet 487 Series (SIN 711.18)	194
QiVi 428 Series (SIN 711.18)	210

Collaborative Seating

cobi 434 Series (SIN 711.18)	220
Node 480 Series (SIN 711.18)	228

Lounge Seating

Brody 488 Series (SIN 711.16)	244
Umami Seating (SIN 711.16)	276
B-Free (SIN 711.11/711.16)	322
i2i 416 Series (SIN 711.11/711.18)	338

Multi-Use Chairs

Kart Series (SIN 711.18)	344
Player 475 Series (SIN 711.18/711.19)	364
Move 490 Series (SIN 711.18/711.19)	380
Snodgrass 474 Series (SIN 711.18)	398
Collaboration (SIN 711.18)	404
Mingle (SIN 711.18)	408
Nooi by Wiesner Hager (SIN 711.18)	412

Stackable Chairs

Max Stacker III 477 Series (SIN 711.19)	424
---	-----

Surface Materials

432

Statement of Line

Seating

Gesture 442 Series

Understanding
 ▶ Page 30
 Specifying
 ▶ Pages 38–42

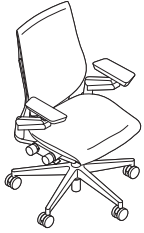

Work Chair with
 Wrapped Back



Work Chair

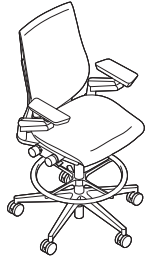

Stool with
 Wrapped Back

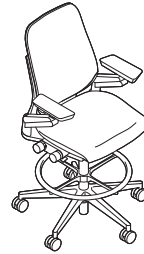

Stool

Leap 462 Series

Understanding
 ▶ Page 44
 Specifying
 ▶ Pages 50–66



Work Chair



Work Chair with
 3D Knit Back

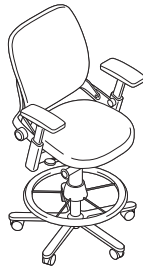

Stool

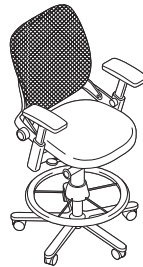

Stool with
 3D Knit Back



Plus Work Chair



Plus Work Chair with
 3D Knit Back

Siento

Understanding
 ▶ Page 68
 Specifying
 ▶ Pages 70–72



High-Back
 Desk Chair with
 Fixed T-Arms



High-Back
 Desk Chair with
 Enclosed Arms



High-Back
 Desk Chair with
 Adjustable T-Arms



Mid-Back
 Desk Chair with
 Fixed T-Arms



Mid-Back
 Desk Chair with
 Enclosed Arms



Mid-Back
 Desk Chair with
 Adjustable T-Arms

Criterion 453 Series

Understanding
 ▶ Page 76
 Specifying
 ▶ Pages 82–98



High-Back
 Work Chair



Mid-Back
 Work Chair



High-Back
 Stool



Mid-Back
 Stool



Plus High-Back
 Work Chair

Think 465 Series

Understanding
▶ Page 100
Specifying
▶ Pages 106–112



Work Chair with
3D Knit Back



Work Chair



Stool with
3D Knit Back



Stool

Steelcase Series 1

Understanding
▶ Page 114
Specifying
▶ Pages 120–121



Work Chair



Stool

Amia 482 Series

Understanding
▶ Page 124
Specifying
▶ Pages 130–150



Work Chair and
Work Chair with Air Back

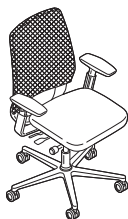

Work Chair with
3D Knit Back and
Work Chair with Air Back
and 3D Microknit



Stool and Stool
with Air Back



Stool with 3D Knit Back
and Stool with Air Back
and 3D Microknit

Reply 466 Series

Understanding
 ▶ Page 152
 Specifying
 ▶ Pages 158–168



Work Chair with Mesh Back



Work Chair

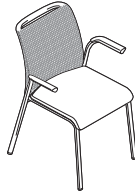

Leg-Base Multi-Use* Chair with Mesh Back with Arms

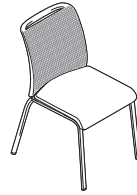

Leg-Base Multi-Use* Chair with Mesh Back without Arms



Leg-Base Multi-Use* Chair with Standard Upholstery with Arms



Leg-Base Multi-Use Chair with Standard Upholstery without Arms



Sled-Base Multi-Use Chair with Mesh Back with Arms

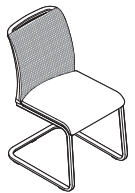

Sled-Base Multi-Use Chair with Mesh Back without Arms



Sled-Base Multi-Use Chair with Standard Upholstery with Arms



Sled-Base Multi-Use Chair with Standard Upholstery without Arms

*Chairs are available with casters.

Jersey Series

Understanding
 ▶ Page 170
 Specifying
 ▶ Pages 174–180



Work Chair

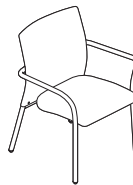

Multi-Use Chair with Arms



Multi-Use Chair without Arms

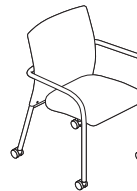

Multi-Use Chair with Arms and with Casters



Multi-Use Chair without Arms and with Casters

Protégé 433 Series

Understanding
 ▶ Page 182
 Specifying
 ▶ Pages 186–192



Work Chair with Arms



Work Chair without Arms



Multi-Use Chair with Arms



Multi-Use Chair without Arms



Sled-Base Multi-Use Chair



Cachet 487 Series



Swivel-Base Work Chair



Leg-Base* Multi-Use Chair without Arms



Leg-Base* Multi-Use Chair with Flip-Up Arms



Swivel-Base Stool

Understanding
▶ Page 194
Specifying
▶ Pages 198–208

*Cachet leg-base chair models also stack.

QiVi 428 Series

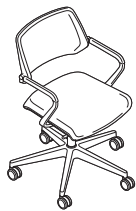

Collaborative Chair with Arms

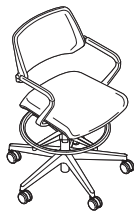

Collaborative Stool

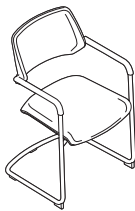

Sled-Base Chair

Understanding
▶ Page 210
Specifying
▶ Pages 216-218

cobi 434 Series



Collaborative Chair with Arms



Collaborative Chair without Arms

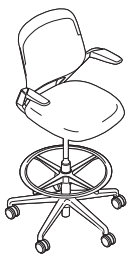

Collaborative Stool with Arms



Collaborative Stool without Arms

Understanding
▶ Page 220
Specifying
▶ Pages 224–226

Node 480 Series

Understanding
▶ Page 228
Specifying
▶ Pages 234–243



Collaborative
Mid-Back Chair



Collaborative Mid-Back
Chair with Personal
Worksurface



Collaborative Mid-Back
Chair with Swivel-Base



Collaborative Mid-Back
Chair with Swivel-Base and
Personal Worksurface



Collaborative Mid-Back
Stool with Swivel-Base



Collaborative
Chair

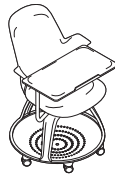

Collaborative Chair with
Personal Worksurface



Collaborative Chair
with Swivel-Base



Collaborative Chair
with Swivel-Base and
Personal Worksurface



Collaborative Stool
with Swivel-Base

Brody 488 Series

Understanding
▶ Pages 244 and 254
Specifying
▶ Pages 260-274

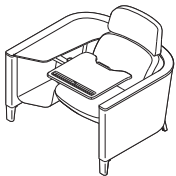

Brody WorkLounge

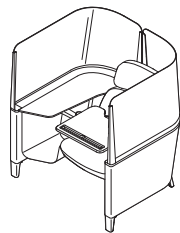

Brody Privacy Lounge

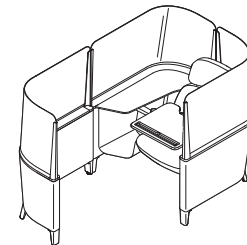

Brody Privacy Lounge
with Extension

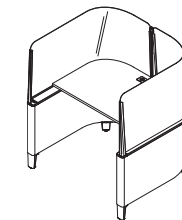

Brody Privacy Desk

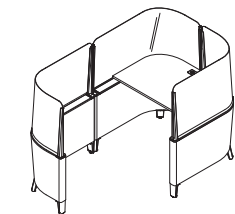

Brody Privacy Desk
with Extension

Umami

Understanding
▶ Page 276
Specifying
▶ Pages 288–316

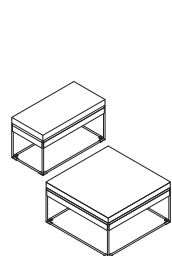

Single Platform

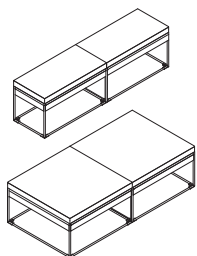

Double Platform

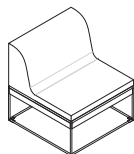

Single, Straight Lounge

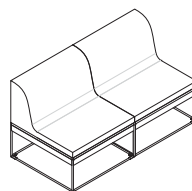

Double, Straight Lounge

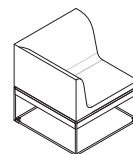

One Arm, Single Lounge

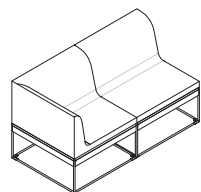

One Arm, Double Lounge

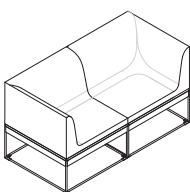

Two Arm, Double Lounge

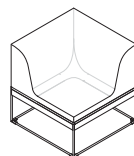

Corner, Single Lounge

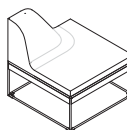

End Cap



Standard Screen

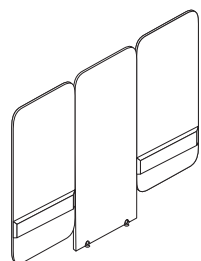

Standard Spanner Screen

B-Free

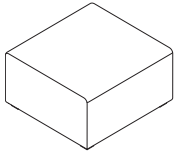

Large Cube
Understanding
▶ Page 322
Specifying
▶ Page 328

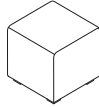

Small Cube
Understanding
▶ Page 322
Specifying
▶ Page 329

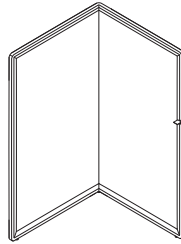

Screens
Understanding
▶ Page 322
Specifying
▶ Page 331

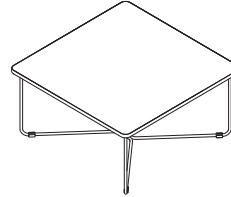

Occasional Tables
Understanding
▶ Page 322
Specifying
▶ Page 333



Rectangle Tables
Understanding
▶ Page 324
Specifying
▶ Page 334



Pint Tables
Understanding
▶ Page 324
Specifying
▶ Page 336

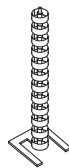

Cable Riser
Understanding
▶ Page 325
Specifying
▶ Page 337

i2i 416 Series



Collaborative
Lounge Chair



Collaborative Lounge
Chair with Tablet Arm

Understanding
▶ Page 338
Specifying
▶ Page 342

Kart Nesting Chairs



with Arms*

*Jury base available



Armless*

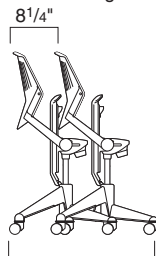

Nested

Understanding
▶ Page 344
Specifying
▶ Pages 348–350

Kart Stools with Casters



with Arms*

*Jury base available



Armless

Understanding
▶ Page 344
Specifying
▶ Page 352

Kart Café Leg-Base Stool with Arms



with Arms

Understanding
 ▶ Page 344
 Specifying
 ▶ Page 356

Kart Leg-Base Stacking Chairs with Arms



with Arms

Understanding
 ▶ Page 344
 Specifying
 ▶ Page 358

Player 475 Series



Leg-Base
 Multi-Use Chair
 without Arms



Leg-Base
 Multi-Use Chair
 with Arms



Sled-Base
 Multi-Use Chair
 without Arms



Sled-Base
 Multi-Use Chair
 with Arms



Stool
 with Arms



Stool
 without Arms

Understanding
 ▶ Page 364
 Specifying
 ▶ Pages 368–378

Move 490 Series



Multi-Use Chair
 without Arms



Multi-Use Chair
 without Arms
 with Casters



Multi-Use Chair
 with Arms



Multi-Use Chair
 with Arms and
 Casters



Stool
 without Arms



Stool
 without Arms
 with Casters

Understanding
 ▶ Page 380
 Specifying
 ▶ Pages 384–397

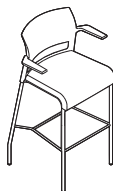

Stool
 with Arms



Stool with Arms
 with Casters



Perching Stool
 without Arms



Perching Stool
 with Arms

Snodgrass 474 Series

Understanding
▶ Page 398
Specifying
▶ Page 402

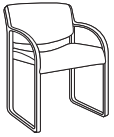

Open-Back
Multi-Use Chair
with Arms

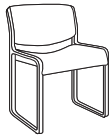

Open-Back
Multi-Use Chair
without Arms

Collaboration

Understanding
▶ Page 404
Specifying
▶ Page 406



Guest Chair
Open

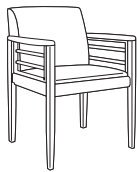

Guest Chair with
Ladder Insert

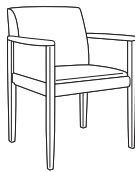

Guest Chair with
Upholstered Insert

Tip: All Collaboration guest chairs are available with plain wood arms.

Mingle

Understanding
▶ Page 408
Specifying
▶ Page 410



Guest Chair

Nooi by Wiesner Hager

Understanding
▶ Page 412
Specifying
▶ Pages 416–422



Frame Linking Chair,
Armless



Frame Linking
Chair with Arms



Sled-Base
Chair, Armless



Cafeteria
Chair, Armless



Cafeteria
Chair with Arms



Stools, Armless

Max-Stacker III 477 Series

Understanding
▶ Page 424
Specifying
▶ Page 428



Stackable Chair

Gesture 442 Series

Gesture is a new sitting experience that is designed for the interface between user and technology, inspired by the movement of the human body, and created for the way we work today.

Back frame, back shell, seat perimeter, arms, and base are standard in black/black or dark/dark color schemes. Polished aluminum base, dark/light, or light/light color schemes are available as options.

Core equalizer provides just the right amount of lumbar support in any angle of recline.

Casters have hard, dual wheels that roll smoothly on carpets. They are 2½" for increased mobility. Soft, dark grey threaded, dual-wheel roll-control are available for use on hard floors or chair mats. Glides are also available as an option.
Tip: Do not roll the chair across asphalt during installation as this may damage the casters.

Variable back stop with four positions is standard.

Back tension requires only 3½ complete turns and accommodates a broader range of users by allowing user to change the rate of increase in force as the chair reclines.

Pneumatic adjustment mechanism is standard. It adjusts with a 5" range. A 3¾" low-range pneumatic seat-height adjustment and a 5½" high-range pneumatic seat-height adjustment are available as options on chairs. Stools have an 8" range.

Seat depth adjusts 2¾" to accommodate various leg lengths.

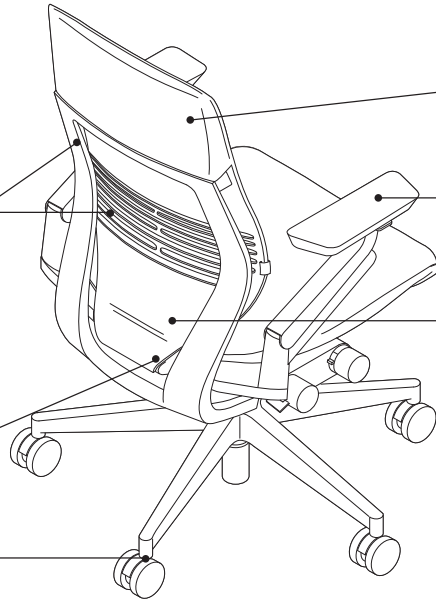

Wrapped upper back upholstery design is available.

360° arm enables 360° of motion to give arm support where it is needed with one release.

3D LiveBack moves with the shape of the user's spine as sitting positions change.

Outer back and outer seat are plastic.

Arm depth can retract 2⅛" to allow user to get closer to worksurface and into tight corners.

Soft arm caps independently pivot 15° inward and 15° outward to accommodate individual user preferences.

Arm width can adjust parallel from 10¼" to 22½" for forearm and elbow support.

Arm height can adjust 4¼" for arm and elbow support.

Passive seat edge angle allows the front edge of the seat to flex 1½" to relieve pressure under the user's thighs.

Seat perimeter is made of flexible elastomer that provides comfort to larger users and allows alternative postures.

Five-arm base is plastic, a polished aluminum base is available as an option.

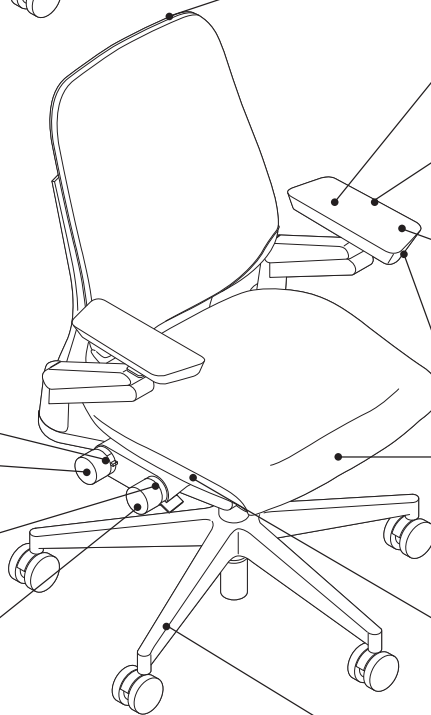

Product Details

Adjustability instructions are included with every chair. Instructions can also be found at www.steelcase.com.

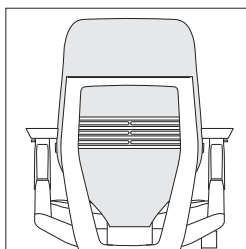

3D LiveBack allows the back to move and conform laterally, sagittally, and torsionally to support individual users.

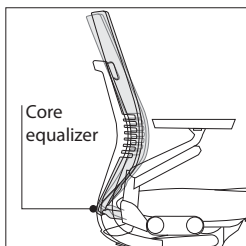

The core equalizer is powered by a torsional spring that adjusts with the angle of the seat and back to provide less lumbar support in a deep recline and more lumbar support in an upright posture.

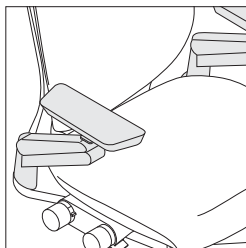

Rectilinear arms with soft caps are standard.

Adjustment Features

Seat Adjustments

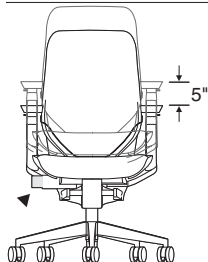

Seat height adjusts pneumatically. To lower, hold handle up while seated. To raise, hold handle up and keep weight off the chair. Range of adjustability is 5", from 16"H to 21"H, and is standard on work chairs. An optional 5½" high-range of adjustability (17"H to 22½"H) and a 3¾" low-range (14½"H to 18¼"H) are available as an option. Stools are standard with an 8¼" range of adjustability (24"H to 32¼"H).

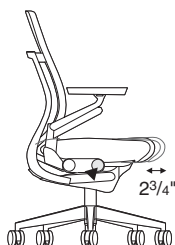

Seat depth adjusts 2¾" (15¾" to 18½") by rotating dial while seated for an easy fine-tuned fit. This feature is standard on work chairs and stools.

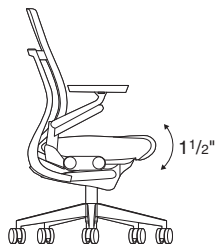

Passive seat edge angle flexes 1½", relieving pressure under the user's thighs. This feature is standard on all work chairs and stools.

Flexible side edges. Comfort goes all the way to edges and requires no adjustment. Perfect for large users and has the ability to side sit.

Adaptive bolstering. The seat has air pockets carefully placed beneath the foam to give consistent comfort and support to a range of users.

Back Adjustments

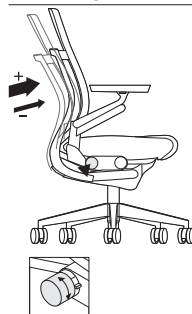

Back tension. Turn the knob forward for more resistance and backward for less resistance. Adjust back tension for appropriate amount of resistance.

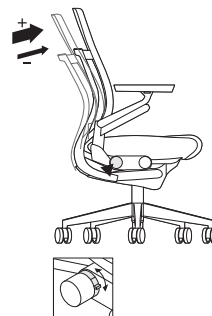

Variable back stop. To lock backrest in upright position, lean forward and flip lever down. Flip lever up to unlock for full-range motion. There are four settings to give just the right angle of recline.

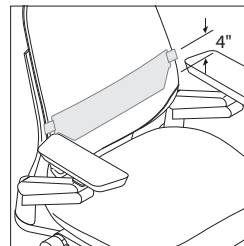

Lumbar height adjusts 4" (5¼" to 9¼") from seat by grabbing exposed tabs and sliding the lumbar support up or down. This feature is optional on work chairs and stools.

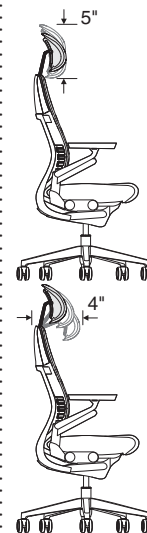

Headrest adjusts 5" vertically and measures 8"H x 10½"W. It tilts 4" forward and the cushion rotates 90°. Plastic shell on the headrest is available in black, merle, or seagull and will match the plastic back shell. Upholstery can match or contrast the seat and back material. It is not available to order separately for installation on existing Gesture chairs. Headrest is available on stools as a special only.

Arm Adjustments

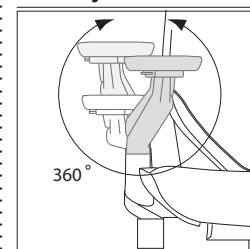

360°-arm. One release enables 360° of motion to give arms support where it is needed. To adjust arm cap position, grasp arm caps and slide in any direction. The 360° provide a great dimensional range for large users and many postures, and ensures proper support when using a range of technology, mobile or fixed.

Gesture 442 Series, continued

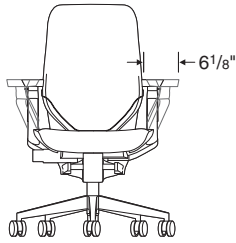

Arm width adjusts parallel 6 1/8" per arm for a total range of 10 1/4" to 22 1/2" between arms.

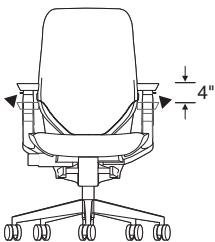

Arm height adjusts independently 4 1/4" (7 1/4"H to 11 1/2"H) to relieve upper back and shoulder fatigue.

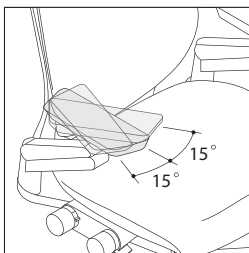

Arms pivot independently 15° inward and 15° outward. Grasp arm and push front to left or right.

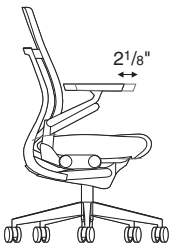

Arm depth adjusts 2 1/8" to enable user to get closer to worksurface.

Other features

Cartoned request on dealer purchase order forces Gesture chairs to ship knocked down in three pieces; the seat and back, the base, and the pneu-matic cylinder. This allows for shipment in a smaller carton. Assembly by a qualified dealer installer is required. Assembly instructions are included. This does not apply to Gesture stools. No additional tools are required for assembly.



Armless models are also available.

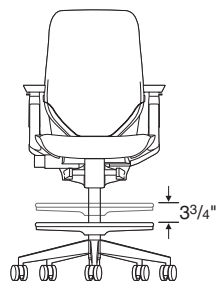

Column and foot ring on stools adjusts by first lifting ring and rotating it counterclockwise to unlock. Then raise or lower ring up to 3 3/4" to desired position before rotating it clockwise to lock.

Surface Materials

▶ See surface materials on page 432 for specific availability or refer to the *Surface Materials Reference Manual* for further information.

Open slats in the back shell will appear as a matching color to the back surface material if specified with Cogent:Connect or 3D Knit. Slats will appear as black if any other seating material is specified.

Upholstery

- Fabric
- Fabric with soil-retardant treatment (option)
- 3D Knit (back and headrest only)
- Leather
- Elmosoft leather
- Select Surfaces leather
- Vinyl
- COM
- COL

Hard components

- (back frame, outer back, arm retainer, and base)
- 4799 Platinum
 - 6205 Black
 - 6527 Merle
 - 6053 Seagull
 - 7250 Sterling Dark
 - 8046 Polished Aluminum
- ▶ See color scheme matrix below.

Headrest shell is determined by the color scheme.

- 6053 Seagull
- 6205 Black
- 6527 Merle

Stool footing finish is determined by the color scheme.

- 0835 Black (Black/Black, Dark/Dark)
- 4799 Platinum Metallic (Dark/Light, Light/Light)

Arm caps

- Black
- Leather



Polished aluminum base is available.

All Steelcase seating with standard upholstery fabrics complies with requirements of the State of California Technical Bulletin 117-2013. All standard seating is labeled to be in compliance with California 117-2013.

Programs & Services

▶ See the *Surface Materials Reference Manual* for further detail about programs and services offered for seating.

The Customer's Own Material (COM) Program

offers the opportunity for customers to select fabrics that are not offered through the standard Steelcase surface materials program for use on Steelcase products. Through the COM program, Steelcase will test your materials for application on Steelcase products. Once approved, you can place your order. Steelcase will facilitate the entire ordering process and give you a production schedule. Steelcase will order the COM fabric directly from the textile manufacturer. For up-to-date information regarding fabric test results for all COM fabrics and details regarding yardage requirements for most Seating lines, visit the COM website. To locate the COM website:

- Visit www.steelcase.com

Soil retardants are treatments that provide long-term soil and stain resistance to a fabric without affecting the shade or the integrity of the fabric. The following Steelcase Textiles are available pretreated with soil retardant. (You do not need to select the soil-retardant option for these fabrics and incur the upcharge.)

- Jacks
- Link
- Spyder

For information on soil retardant fabrics on Select Surfaces, please refer to the *Surface Materials Reference Manual*.

Soil-retardant treatment is available on all other seating fabrics at an additional upcharge per seating unit. To order this option, please select "Soil-Retardant Treatment" under "Optional Accessories."

For soil-retardant treatment on COMs, please select "Soil-Retardant Treatment" under "Optional Accessories." Minimums or additional yardage may be required. Please contact the vendor directly for specific information.

Extended lead times may be necessary for this service.

Contact your Steelcase Solutions Fulfillment Team Representative at 1.888.STEELCASE (1.888.783.3522) or send an email to lineone@steelcase.com.

Dimensions

▶ Page 36

Resources

Online Resources

- ▶ Interactive User Guide available on www.steelcase.com
- ▶ Model sales conversation available on village.steelcase.com
- ▶ Adjustability video available on www.steelcase.com
- ▶ Environmental profiles available on www.steelcase.com/sustainability

Color Scheme Matrix

Color Scheme	Back Frame	Back Shell/ Headrest	Seat Perimeter	Arms	Base	Cylinder
Black/Black	Molded Black-6205	Molded Black-6205	Molded Black-6205	Molded Black-6205	Molded Black-6205 or optional Polished Aluminum-8046	Painted Black-0835
Dark/Dark	Painted Sterling Dark Textured-7250	Molded Merle-6527	Molded Merle-6527	Molded Merle-6527	Painted Sterling Dark Textured-7250 or optional Polished Aluminum-8046	Painted Black-0835
Dark/Light	Painted Platinum Metallic-4799	Molded Merle-6527	Molded Merle-6527	Molded Merle-6527	Painted Platinum Metallic-4799 or optional Polished Aluminum-8046	Painted Platinum Metallic-4799
Light/Light	Painted Platinum Metallic-4799	Molded Seagull -6053	Molded Seagull -6053	Molded Merle-6527	Painted Platinum Metallic-4799 or optional Polished Aluminum-8046	Painted Platinum Metallic-4799

Gesture Upholstery

What Is It?

Fabric, leather, or vinyl-covered back and seat, 3D Knit back.

Standard upholstery design

Cogent: Connect

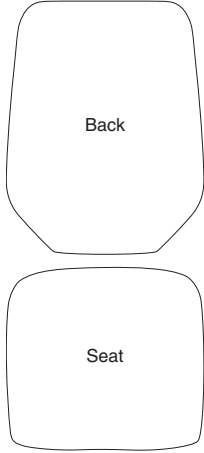

3D Knit on Back only

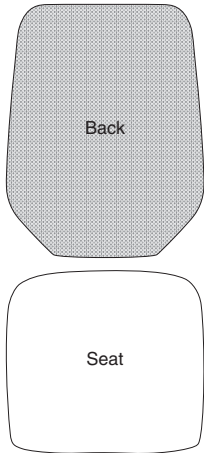

3D Knit back is made up of three layers: the 3D Knit, a solid fabric that matches the 3D Knit color, and the polyurethane cushion that provides exceptional comfort. The seat on these models can be specified with Cogent: Connect fabric colors to match the 3D Knit color, or in any other material.

Stitched upholstery design

Leather, Vinyl, and All Other Fabrics

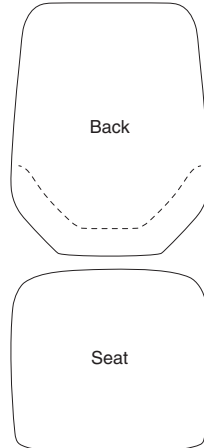

Stitched seams are included on the back cushion of the following:

- Leather
- Vinyl
- Upholstery
- Customer's Own Leather (COL)
- Vinyl
- Select Customer's Own Material/Vinyl (COM)

Pattern alignment at the lumbar seam cannot be guaranteed.

Open slats in the back shell will appear as a matching color to the back surface material if specified with Cogent:Connect or 3D Knit. Slats will appear as black if any other seating material is specified.

Chairs with headrest only

Leather, Vinyl, and All Other Fabrics

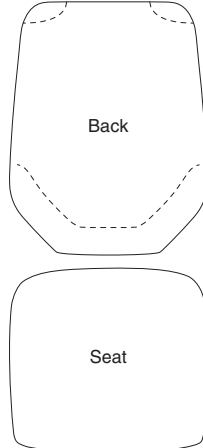

Additional stitched seams in the upper left and right corner of the back cushion on Gesture chairs with headrest are included of the following:

- Leather
- Vinyl
- Upholstery
- Customer's Own Leather (COL)
- Vinyl
- Select Customer's Own Material/Vinyl (COM)

Tip: Fabrics that show a distinct pattern or texture may demonstrate an undesirable contrast at the upper left and right corners of the top of the back.

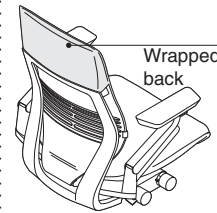
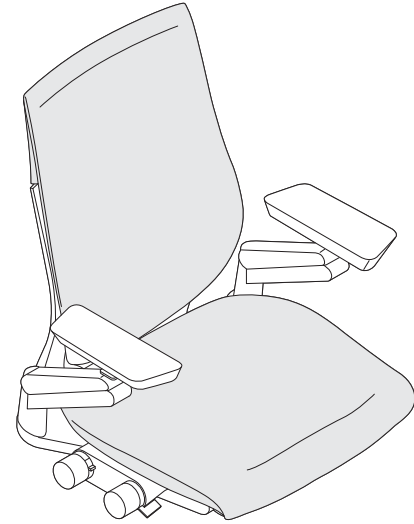

Wrapped upper back is upholstered to the top of the back frame.

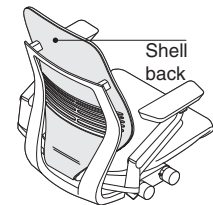

Plastic shell back is fully exposed.

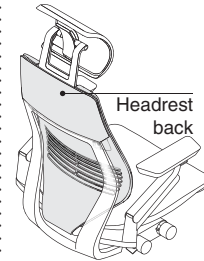

Headrest chair back is upholstered to the top of the back frame.

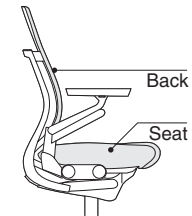

Seat and back cushions can be removed and replaced if damaged.

Dimensions

Gesture 442 Series

Features	Overall Depth	Width	Height	Seat Depth	Functional Seat Depth	Seat Width	Seat Height from Floor	Ring Height from Floor	Back Width	Back Height from Seat
Gesture 442 Series										
Work Chairs										
Adjustable Seat Depth	21" to 23 ⁵ / ₈ "	22 ³ / ₈ " to 34 ⁵ / ₈ "	39 ¹ / ₄ " to 44 ¹ / ₄ "	18 ¹ / ₄ "	15 ³ / ₄ " to 18 ¹ / ₂ "	20"	16" to 21" (14 ¹ / ₂ " to 18 ¹ / ₄ ", 17" to 22 ¹ / ₂ " optional)	N.A.	16 ¹ / ₄ "	24 ¹ / ₁₆ "
Work Chair with Headrest										
Adjustable Seat Depth	21" to 23 ⁵ / ₈ "	22 ³ / ₈ " to 34 ⁵ / ₈ "	47" to 57"	18 ¹ / ₄ "	15 ³ / ₄ " to 18 ¹ / ₂ "	20"	16" to 21" (14 ¹ / ₂ " to 18 ¹ / ₄ ", 17" to 22 ¹ / ₂ " optional)	N.A.	16 ¹ / ₄ "	25 ³ / ₈ "
Stools										
Adjustable Seat Depth	21" to 23 ⁵ / ₈ "	22 ³ / ₈ " to 34 ⁵ / ₈ "	47 ³ / ₈ " to 55 ⁵ / ₈ "	18 ¹ / ₄ "	15 ³ / ₄ " to 18 ¹ / ₂ "	20"	24" to 32 ¹ / ₄ "	10 ¹ / ₄ " to 14"	16 ¹ / ₄ "	24 ¹ / ₁₆ "

Dimensions were measured with BIFMA CMD (chair-measuring device).

*Seat width at the front of the cushion is 18¹/₄"W.

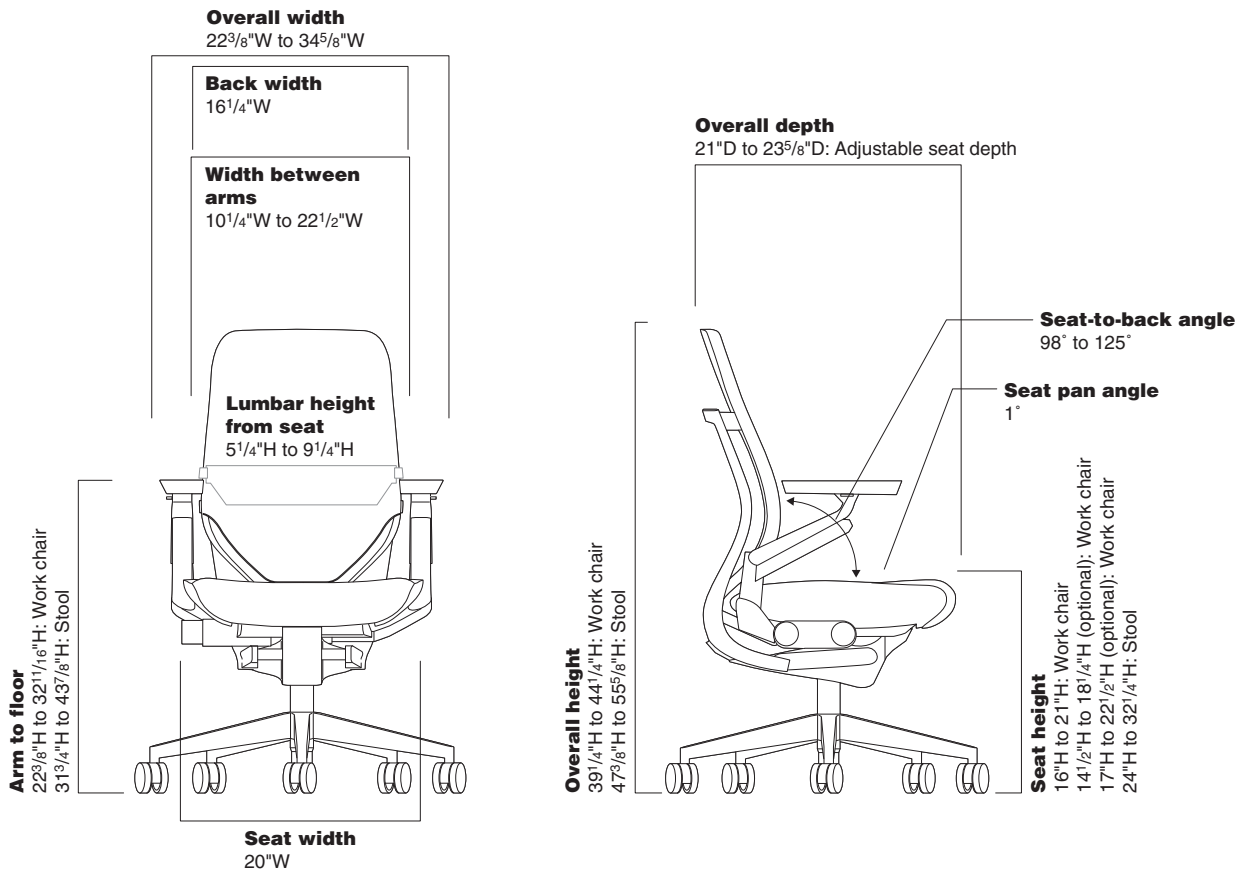

• Back Lumbar Height	• Lumbar Flex Zone	• Width Between Arms	• Width Between Fixed Arms	• Arm to Floor	• Arm Height from Seat	• Arm Cap Pivot Range	• Seat Pan Angle	• Angle Between Seat and Back
Work Chairs								
9¼"	4"	10¼" to 22½"	19"	23⅜" to 32⅛"	7¼" to 11½"	15° inward, 15° outward	1°	98° to 125°
Work Chair with Headrest								
9¼"	4"	10¼" to 22½"	19"	23⅜" to 32⅛"	7¼" to 11½"	15° inward, 15° outward	1°	98° to 125°
Stools								
9¼"	4"	10¼" to 22½"	19"	31¼" to 43⅞"	7¼" to 11½"	15° inward, 15° outward	1°	98° to 125°
:	:	:	:	:	:	:	:	:

Gesture 442 Series Work Chairs

SIN 711.18



Tip: For more information regarding color schemes, see page 33.

Tip: Seat and back will be a matching textile unless 3D Knit is specified.

Standard Includes		Required to Specify
<ul style="list-style-type: none"> ▶ Need help? Product details, page 30 	<ul style="list-style-type: none"> • 5" pneumatic seat-height adjustment (16"-21") • 360° independent height-, width-, pivot-, and depth-adjustable arms and soft arm caps: black plastic • Frame, seat shell, outer back, and five-arm base: plastic • 2¾" seat depth adjustment • Standard upholstery design on seat: fabric price group 1 • Shell back chair, if selected: fabric price group 1 • Wrapped back chair, if selected: fabric price group 1 • 3D Knit on back only, if selected • 2½" diameter, hard-composition, dual-wheel casters: black 	<ol style="list-style-type: none"> 1 Style number 2 Plastic color scheme for frame, seat shell, outer back, and base (see below under Required Selections) 3 Fabric color number for upholstery on seat and back, if selected 4 3D Knit color number for upholstery on back, if selected 5 Options, if selected (see below) <ul style="list-style-type: none"> ▶ See <i>Surface Materials</i>, page 432.

Required Selections	Price	Required to Specify
Color Scheme		
• Black/Black	No cost	Specify with <i>black/black color scheme</i> .
• Dark/Dark	No cost	Specify with <i>dark/dark color scheme</i> .
• Dark/Light	+\$ 41	Specify with <i>dark/light color scheme</i> .
• Light/Light	+\$ 41	Specify with <i>light/light color scheme</i> .

Options	Price	Required to Specify
Surface Materials		
Contrasting		
• Contrasting fabrics	+\$ 31	Specify with <i>contrasting</i> .
Upholstery on seat		
• Fabric price group 1	No cost	Specify fabric color number.
• Fabric price group 2	+\$ 10	Specify fabric color number.
• Fabric price group 3	+\$ 26	Specify fabric color number.
• Fabric price group 4	+\$ 35	Specify fabric color number.
• Fabric price group 5	+\$ 42	Specify fabric color number.
• Fabric price group 6	+\$ 51	Specify fabric color number.
• Fabric price group 7	+\$ 62	Specify fabric color number.
• Fabric price group 8	+\$ 77	Specify fabric color number.
• Fabric price group 9	+\$ 94	Specify fabric color number.
• Fabric price group 10	+\$109	Specify fabric color number.
• Steelcase leather upholstery	+\$313	Specify leather color number.
• Select Surfaces leather price group 1	+\$313	▶ See <i>Surface Materials Reference Manual</i> .
• Elmosoft leather upholstery	+\$367	Specify Elmosoft leather color number.
• Select Surfaces leather price group 2	+\$367	▶ See <i>Surface Materials Reference Manual</i> .
• Steelcase vinyl	+\$ 10	Specify vinyl color number.
• Customer's Own Material/Vinyl (COM-Sewn)	No cost	▶ See <i>Surface Materials Reference Manual</i> .
• Customer's Own Leather (COL-Sewn)	+\$135	Specify leather color number.
Upholstery on back		
• Fabric price group 1	No cost	Specify fabric color number.
• Fabric price group 2	+\$ 10	Specify fabric color number.
• Fabric price group 3	+\$ 26	Specify fabric color number.
• Fabric price group 4	+\$ 35	Specify fabric color number.
• Fabric price group 5	+\$ 42	Specify fabric color number.
• Fabric price group 6	+\$ 51	Specify fabric color number.
• Fabric price group 7	+\$ 62	Specify fabric color number.
• Fabric price group 8	+\$ 77	Specify fabric color number.
• Fabric price group 9	+\$ 94	Specify fabric color number.
• Fabric price group 10	+\$109	Specify fabric color number.
• 3D Knit	+\$ 59	Specify 3D Knit fabric color number.

▶ Options, continued on next page

▶ Detailed dimensions, page 36

SIN 711.18

► Options, continued from previous page

Options	Price	Required to Specify
Surface Materials, continued	Upholstery on back, continued	
	• Steelcase leather upholstery +\$313	Specify leather color number. ► See <i>Surface Materials Reference Manual</i> .
	• Select Surfaces leather price group 1 +\$313	
	• Elmosoft leather upholstery +\$367	Specify Elmosoft leather color number. ► See <i>Surface Materials Reference Manual</i> .
	• Select Surfaces leather price group 2 +\$367	
	• Steelcase vinyl +\$ 10	Specify vinyl color number. ► See <i>Surface Materials Reference Manual</i> .
	• Customer's Own Material/Vinyl (COM-Sewn) No cost	
	• Customer's Own Leather (COL-Sewn) +\$135	Specify leather color number.
	Soil-retardant treatment +\$ 25	Specify with soil-retardant treatment.
	Polished aluminum base package	
	• Polished aluminum base on chairs +\$136	Specify with polished aluminum base.
Arms	• 360° independent height-, width-, pivot-, and depth-adjustable arms with leather arm caps +\$162	Specify with 360° independent height-, width-, pivot-, and depth-adjustable arms and select leather color number.
	• 360° independent height-, width-, pivot-, and depth-adjustable arms with Elmosoft leather arm caps +\$190	Specify with 360° independent height-, width-, pivot-, and depth-adjustable arms and select Elmosoft leather color number.
	• Fixed arms -\$ 95	Specify with fixed arms.
	• Armless -\$271	Specify without arms.
Seat Height	• 3 ³ / ₄ " low-range pneumatic seat-height adjustment (14 ¹ / ₂ " to 18 ¹ / ₄ ") +\$ 58	Specify with low-range pneumatic seat-height adjustment.
	• 5 ¹ / ₂ " high-range pneumatic seat-height adjustment (17" to 22 ¹ / ₂ ") +\$ 58	Specify with high-range pneumatic seat-height adjustment.
Lumbar	• Adjustable lumbar support +\$ 31	Specify with adjustable lumbar height.
Casters	• Soft, dark grey threaded, dual-wheel roll-control casters for use on hard floors +\$ 25	Specify with soft roll-control casters.
Glides	• Glides: plastic +\$ 25	Specify with glides.

Specification Information

Style Number	Base Price

Wrapped Back Chair

442A40	\$1538
--------	--------

Shell Back Chair

442A30	\$1512
--------	--------

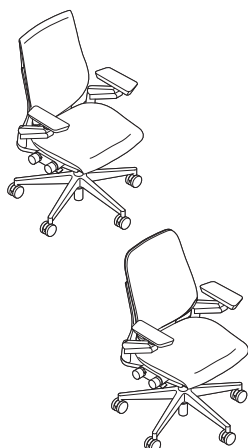

Gesture 442 Series Work Chair with Headrest

SIN 711.18

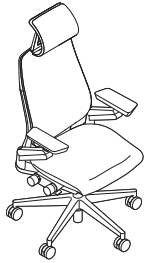

Tip: For more information regarding color schemes, see page 33.

Tip: Headrest upholstery can match or contrast the seat and back upholstery.

Tip: Seat and back will be a matching textile unless 3D Knit is specified.

Standard Includes	Required to Specify
<ul style="list-style-type: none"> ▶ Need help? Product details, page 30 • 5" pneumatic seat-height adjustment (16"-21") • 360° independent height-, width-, pivot-, and depth-adjustable arms and soft arm caps: black plastic • Frame, seat shell, outer back, and five-arm base: plastic • 2¾" seat depth adjustment • Standard upholstery design on seat: fabric price group 1 • Adjustable headrest, standard upholstery • 3D Knit on back and headrest only, if selected • 2½" diameter, hard-composition, dual-wheel casters: black 	<ol style="list-style-type: none"> 1 Style number 2 Plastic color scheme for frame, seat shell, outer back, headrest, and base (see below under Required Selections) 3 Fabric color number for upholstery on seat and back, if selected 4 Fabric color number for upholstery on headrest 5 3D Knit color number for upholstery on back, if selected 6 Options, if selected (see below) <p>▶ See <i>Surface Materials</i>, page 432.</p>

Required Selections	Price	Required to Specify
Color Scheme		
• Black/Black	No cost	Specify with <i>black/black color scheme</i> .
• Dark/Dark	No cost	Specify with <i>dark/dark color scheme</i> .
• Dark/Light	+\$ 41	Specify with <i>dark/light color scheme</i> .
• Light/Light	+\$ 41	Specify with <i>light/light color scheme</i> .

Options	Price	Required to Specify
Surface Materials		
Contrasting		
• Contrasting fabrics	+\$ 31	Specify with <i>contrasting</i> .
Upholstery on seat		
• Fabric price group 1	No cost	Specify fabric color number.
• Fabric price group 2	+\$ 10	Specify fabric color number.
• Fabric price group 3	+\$ 26	Specify fabric color number.
• Fabric price group 4	+\$ 35	Specify fabric color number.
• Fabric price group 5	+\$ 42	Specify fabric color number.
• Fabric price group 6	+\$ 51	Specify fabric color number.
• Fabric price group 7	+\$ 62	Specify fabric color number.
• Fabric price group 8	+\$ 77	Specify fabric color number.
• Fabric price group 9	+\$ 94	Specify fabric color number.
• Fabric price group 10	+\$109	Specify fabric color number.
• Select Surfaces leather price group 1	+\$313	▶ See <i>Surface Materials Reference Manual</i> .
• Steelcase leather upholstery	+\$313	Specify leather color number.
• Elmosoft leather upholstery	+\$367	Specify Elmosoft leather color number.
• Select Surfaces leather price group 2	+\$367	▶ See <i>Surface Materials Reference Manual</i> .
• Steelcase vinyl	+\$ 10	Specify vinyl color number.
• Customer's Own Material/Vinyl (COM-Sewn)	No cost	▶ See <i>Surface Materials Reference Manual</i> .
• Customer's Own Leather (COL-Sewn)	+\$135	Specify leather color number.

▶ Options, continued on next page

▶ Detailed dimensions, page 36

► Options, continued from previous page

Options	Price	Required to Specify
Upholstery on back		
• Fabric price group 1	No cost	Specify fabric color number.
• Fabric price group 2	+\$ 10	Specify fabric color number.
• Fabric price group 3	+\$ 26	Specify fabric color number.
• Fabric price group 4	+\$ 35	Specify fabric color number.
• Fabric price group 5	+\$ 42	Specify fabric color number.
• Fabric price group 6	+\$ 51	Specify fabric color number.
• Fabric price group 7	+\$ 62	Specify fabric color number.
• Fabric price group 8	+\$ 77	Specify fabric color number.
• Fabric price group 9	+\$ 94	Specify fabric color number.
• Fabric price group 10	+\$109	Specify fabric color number.
• 3D Knit	+\$ 59	Specify 3D Knit fabric color number.
• Steelcase leather upholstery	+\$313	Specify leather color number.
• Select Surfaces leather price group 1	+\$313	► See <i>Surface Materials Reference Manual</i> .
• Elmosoft leather upholstery	+\$367	Specify Elmosoft leather color number.
• Select Surfaces leather price group 2	+\$367	► See <i>Surface Materials Reference Manual</i> .
• Steelcase vinyl	+\$ 10	Specify vinyl color number.
• Customer's Own Material/Vinyl (COM-Sewn)	No cost	► See <i>Surface Materials Reference Manual</i> .
• Customer's Own Leather (COL-Sewn)	+\$135	Specify leather color number.
Soil-retardant treatment		
	+\$ 25	Specify with <i>soil-retardant treatment</i> .
Polished aluminum base package		
• Polished aluminum base on chairs	+\$136	Specify with <i>polished aluminum base</i> .
Arms		
• 360° independent height-, width-, pivot-, and depth-adjustable arms with leather arm caps	+\$162	Specify with <i>360° independent height-, width-, pivot-, and depth-adjustable arms</i> and select leather color number.
• 360° independent height-, width-, pivot-, and depth-adjustable arms with Elmosoft leather arm caps	+\$190	Specify with <i>360° independent height-, width-, pivot-, and depth-adjustable arms</i> and select Elmosoft leather color number.
• Fixed arms	-\$ 95	Specify with <i>fixed arms</i> .
• Armless	-\$271	Specify <i>without arms</i> .
Seat Height		
• 3 ³ / ₄ " low-range pneumatic seat-height adjustment (14 ¹ / ₂ " to 18 ¹ / ₄ ")	+\$ 58	Specify with <i>low-range pneumatic seat-height adjustment</i> .
• 5 ¹ / ₂ " high-range pneumatic seat-height adjustment (17" to 22 ¹ / ₂ ")	+\$ 58	Specify with <i>high-range pneumatic seat-height adjustment</i> .
Lumbar		
• Adjustable lumbar support	+\$ 31	Specify with <i>adjustable lumbar height</i> .
Casters		
• Soft, dark grey treaded, dual-wheel roll-control casters for use on hard floors	+\$ 25	Specify with <i>soft roll-control casters</i> .
Glides		
• Glides: plastic	+\$ 25	Specify with <i>glides</i> .

Gesture 442 Series

Specification Information

Style Number	Base Price
442A50	\$1794



Gesture 442 Series Stools

SIN 711.18

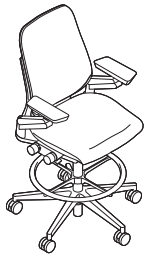

Tip: For more information regarding color schemes, see page 33.

Tip: Seat and back will be a matching textile unless 3D Knit is specified.

Standard Includes		Required to Specify
<ul style="list-style-type: none"> ▶ Need help? Product details, page 30 	<ul style="list-style-type: none"> • 8¼" pneumatic seat-height adjustment (24"-32¼") • 360° independent height-, width-, pivot-, and depth-adjustable arms and soft arm caps: black plastic • Frame, seat shell, outer back, and five-arm base: plastic • 2¾" seat depth adjustment • Column and 4" adjustable foot ring • Standard upholstery design on seat: fabric price group 1 • Shell back stool, if selected: fabric price group 1 • Wrapped back stool, if selected: fabric price group 1 • 3D Knit on back only, if selected • 2½" diameter, hard-composition, dual-wheel casters: black 	<ol style="list-style-type: none"> 1 Style number 2 Plastic color scheme for frame, seat shell, outer back, and base (see below under Required Selections) 3 Fabric color number for upholstery on seat and back, if selected 4 3D Knit color number for upholstery on back, if selected 5 Options, if selected (see below) <ul style="list-style-type: none"> ▶ See <i>Surface Materials</i>, page 432.

Required Selections	Price	Required to Specify
Color Scheme		
• Black/Black	No cost	Specify with <i>black/black color scheme</i> .
• Dark/Dark	No cost	Specify with <i>dark/dark color scheme</i> .
• Dark/Light	+\$ 41	Specify with <i>dark/light color scheme</i> .
• Light/Light	+\$ 41	Specify with <i>light/light color scheme</i> .

Options	Price	Required to Specify
Surface Materials		
Contrasting		
• Contrasting fabrics	+\$ 31	Specify with <i>contrasting</i> .

Upholstery on seat		
• Fabric price group 1	No cost	Specify fabric color number.
• Fabric price group 2	+\$ 10	Specify fabric color number.
• Fabric price group 3	+\$ 26	Specify fabric color number.
• Fabric price group 4	+\$ 35	Specify fabric color number.
• Fabric price group 5	+\$ 42	Specify fabric color number.
• Fabric price group 6	+\$ 51	Specify fabric color number.
• Fabric price group 7	+\$ 62	Specify fabric color number.
• Fabric price group 8	+\$ 77	Specify fabric color number.
• Fabric price group 9	+\$ 94	Specify fabric color number.
• Fabric price group 10	+\$109	Specify fabric color number.
• Steelcase leather upholstery	+\$313	Specify leather color number.
• Select Surfaces leather price group 1	+\$313	▶ See <i>Surface Materials Reference Manual</i> . Specify Elmosoft leather color number.
• Elmosoft leather upholstery	+\$367	▶ See <i>Surface Materials Reference Manual</i> . Specify vinyl color number.
• Select Surfaces leather price group 2	+\$367	▶ See <i>Surface Materials Reference Manual</i> .
• Steelcase vinyl	+\$ 10	
• Customer's Own Material/Vinyl (COM-Sewn)	No cost	
• Customer's Own Leather (COL-Sewn)	+\$135	Specify leather color number.

Upholstery on back		
• Fabric price group 1	No cost	Specify fabric color number.
• Fabric price group 2	+\$ 10	Specify fabric color number.
• Fabric price group 3	+\$ 26	Specify fabric color number.
• Fabric price group 4	+\$ 35	Specify fabric color number.
• Fabric price group 5	+\$ 42	Specify fabric color number.
• Fabric price group 6	+\$ 51	Specify fabric color number.
• Fabric price group 7	+\$ 62	Specify fabric color number.
• Fabric price group 8	+\$ 77	Specify fabric color number.
• Fabric price group 9	+\$ 94	Specify fabric color number.
• Fabric price group 10	+\$109	Specify fabric color number.
• 3D Knit	+\$ 59	Specify 3D knit fabric color number.
• Select Surfaces leather price group 1	+\$313	▶ See <i>Surface Materials Reference Manual</i> . Specify leather color number.
• Steelcase leather upholstery	+\$313	Specify Elmosoft leather color number.
• Elmosoft leather upholstery	+\$367	▶ See <i>Surface Materials Reference Manual</i> . Specify vinyl color number.
• Select Surfaces leather price group 2	+\$367	▶ See <i>Surface Materials Reference Manual</i> .
• Steelcase vinyl	+\$ 10	
• Customer's Own Material/Vinyl (COM-Sewn)	No cost	
• Customer's Own Leather (COL-Sewn)	+\$135	Specify leather color number.

▶ Options, continued on next page

▶ Detailed dimensions, page 36

SIN 711.18

► Options, continued from previous page

Options	Price	Required to Specify
Surface Materials, continued		
Soil-retardant treatment	+\$ 25	Specify with soil-retardant treatment.
Polished aluminum base package		
• Polished aluminum base on chairs	+\$136	Specify with polished aluminum base.
Arms		
• 360° independent height-, width-, pivot-, and depth-adjustable arms with leather arm caps	+\$162	Specify with 360° independent height-, width-, pivot-, and depth-adjustable arms and select leather color number.
• 360° independent height-, width-, pivot-, and depth-adjustable arms with Elmosoft leather arm caps	+\$190	Specify with 360° independent height-, width-, pivot-, and depth-adjustable arms and select Elmosoft leather color number.
• Fixed arms	-\$ 95	Specify with fixed arms.
• Armless	-\$271	Specify without arms.
Lumbar		
• Adjustable lumbar support	+\$ 31	Specify with adjustable lumbar height.
Casters		
• Soft, dark grey threaded, dual-wheel roll-control casters for use on hard floors	+\$ 25	Specify with soft roll-control casters.
Glides		
• Glides: plastic	+\$ 25	Specify with glides.

Specification Information

• Style Number	• Base Price
•	•
•	•
•	•

Wrapped Back Stool

442B40	\$1764
•	•
•	•
•	•

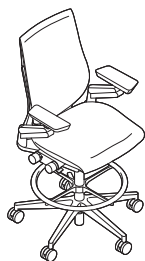

Shell Back Stool

442B30	\$1738
•	•
•	•
•	•

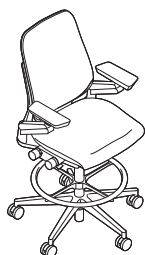

Leap 462 Series

Leap is a high-performance chair for customers who place the highest value on ergonomics, health, and productivity.

Outer back and outer seat are plastic.

LiveBack moves with the shape of the user's spine as sitting positions change.

Lumbar height adjusts 5" to provide additional lower back support. It is standard on all chairs, but may be omitted.

Arm height can adjust independently within a 4" range to help relieve upper back and shoulder fatigue.

Seat depth adjusts within a 3" range to accommodate users of varying leg lengths. Seat depth is standard on all models.

Five-arm base is available in plastic or polished aluminum.

Casters have hard, dual-wheels that roll smoothly on carpets. They are 2½" for increased mobility. Soft, dual-wheel casters are available for use on hard floors or chair mats. Stools are standard with 2" hard casters. Soft casters are available as an option.

Tip: Do not roll the chair across asphalt during installation as this may damage the casters.

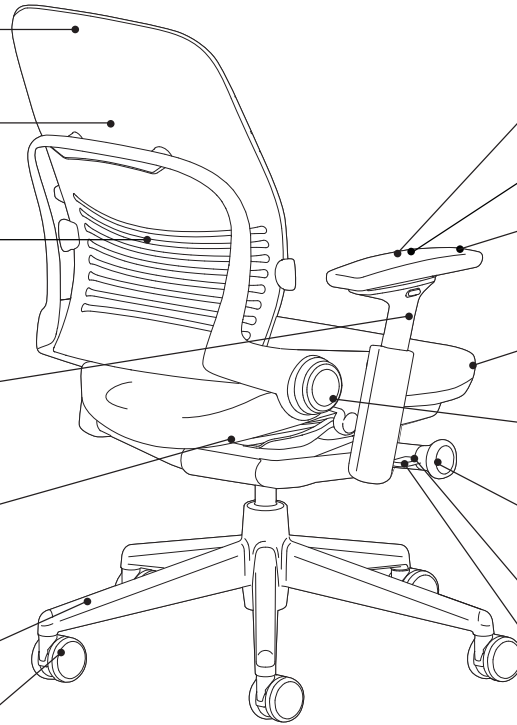

Arm depth can retract 3" to allow user to get closer to worksurface and into tight corners.

Arm width can adjust 4½" overall to provide forearm support.

Arm caps can pivot 30° in and out to accommodate individual user preferences.

Passive seat edge angle allows the front edge of the seat to flex 1½" to relieve pressure under the user's thighs.

Lower back firmness changes the amount of firmness user feels in lower back. Requires only two complete turns.

Upper back force requires only five complete turns and accommodates a broader range of users by allowing user to change the rate of increase in force as the user reclines.

Variable back stop with five positions is standard.

Seat height adjusts within a 5" range with a pneumatic adjustment mechanism. A 7" range is available as an option. Stools have an 8" range.

Product Details

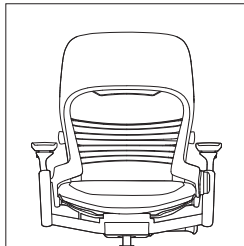

Parallel slats in the LiveBack shell provide extensive flexibility to allow back to conform to individual users.

Leap Plus offers the benefits and functionality of the standard Leap chair, including LiveBack Technology, to users weighing up to 500 pounds.



Rectilinear arms with soft caps are standard.

Models are standard with adjustable seats that include seat depth and passive seat edge angle.

Adjustability instructions are included with every chair. Fully adjustable arm models include instructions under the arm cap. Instructions can also be found at www.steelcase.com

Controls under the seat include tactile braille designators.

Cartoned request on your dealer purchase order means Leap chairs will ship knocked down with the chair base separated from the rest of the chair. This allows for shipment in a smaller carton. Assembly instructions are included. This does not apply to Leap stools, Leap Plus, or Leap WorkLounge.

Uncartoned request on your dealer purchase order means Leap chairs will ship fully assembled.

Adjustment Features

Seat Adjustments

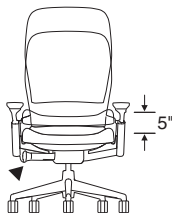

Seat height adjusts pneumatically. To lower, hold handle up while seated.

To raise, hold handle up and keep your weight off the chair. Range of adjustability is 5", from 15½"H to 20½"H, and is standard on work chairs and stools. A 7" range of adjustability (17"H to 24"H) is available as an option. Stools are standard with an 8" range of adjustability (22"H to 30"H). Leap Plus is standard with a 4" range of adjustability (15½"H to 19½"H). A 5" range (17½"H to 22½"H) is available as an option.

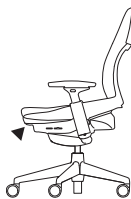

Passive seat edge angle flexes 1½", relieving pressure under the user's thighs. This feature is standard on all work chairs and stools.

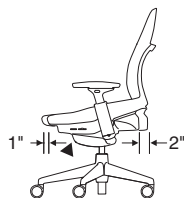

Seat depth adjusts 3" (15¾"-18¾") by pulling handle up. Slide seat forward or back to accommodate various leg lengths. Release handle to lock. This feature is standard on work chairs and stools. Seat depth adjustment range for Leap Plus is 2" (16¾"-18¾").

Back Adjustments

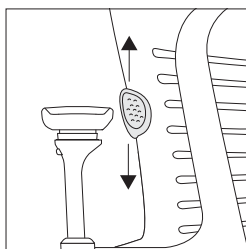

Lumbar height adjusts 5" (5¼" to 10¼" from seat, 6½" to 11½" on Plus chairs) by grabbing exposed tabs and sliding the lumbar support up or down. This feature is standard on work chairs and stools, but may be omitted.

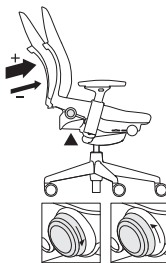

Lower back firmness adjusts by turning knob two complete turns. Forward increases firmness. Backward decreases firmness. This feature is standard on work chairs and stools.

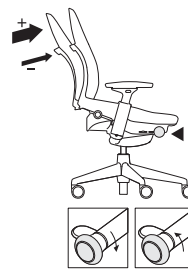

Upper back force adjusts by turning knob five complete turns. Turn knob forward to increase rate of tension; backward to decrease. This feature is standard on work chairs and stools.

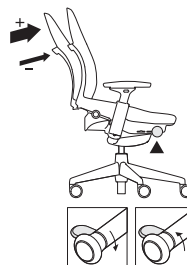

Variable back stop. Rotate handle up or down to set recline angle. Lean back to desired back angle. Five stops are available. This feature is standard on work chairs and stools.

Tip: To stop in upright position, remove weight from back and rotate lever up.

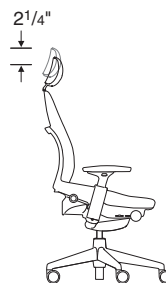

Headrest (option) adjusts 2¼" vertically and adds 6¾" to 9" to the overall height. Plastic shell on the headrest is available in black only. Upholstery is available to match the seat material or black vinyl only. Headrest is not available on stools, Leap Plus models, or when the fire code option (FCS) is selected.

Arm Adjustments

Rectilinear height-, width-, pivot-, and depth-adjustable arms come standard on all arm models of chairs and stools.

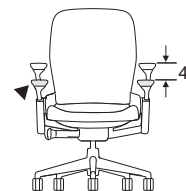

Arm height adjusts independently within a range of 4" (7"-11" from the seat, 7¼"-11¼" on Plus models). Push button on outside and under arm cap in while moving arms up or down. Releasing buttons locks arms in position.

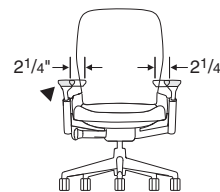

Arm width adjusts 2¼" each independently on chairs with this option. Grasp arm and move in or out.

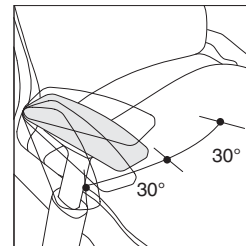

Arms pivot independently 30° inward and outward. Grasp arm and push front to left or right.

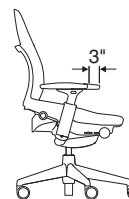

Arm depth adjusts approximately 3" to enable user to get closer to worksurface.

Leap 462 Series, continued

Other Features

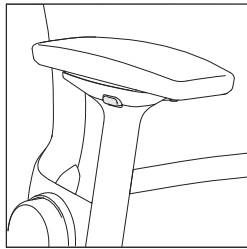

Height-only adjustable arm is also available and adjusts 4".



Armless models are also available.

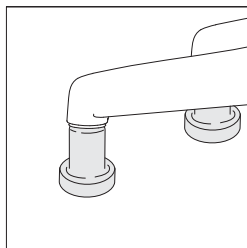

Glides are available as an option, except on chairs with polished aluminum package. Glides ship with chair or stool for field installation and maintain same height as casters.

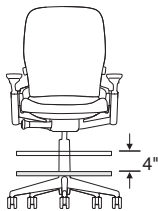

Foot ring height on stools adjusts by first lifting ring and rotating it counter-clockwise to unlock. Then raise or lower ring up to 4" to desired position before rotating it clockwise to lock.

Soft-wheel casters for hard floors are available for specific applications.

Surface Materials

▶ See surface materials on page 432 for specific availability or refer to the *Surface Materials Reference Manual* for further information.

Upholstery

- Fabric
- Fabric with soil-retardant treatment (option)
- 3D Knit (back only)
- Leather
- Elmosoft leather
- Select Surfaces leather
- Vinyl
- COM
- COL

Hard components

- (ribbon back frame, outer back, arm retainer, and base)
- 6205 Black
 - 6249 Platinum
 - 6259 Midnight

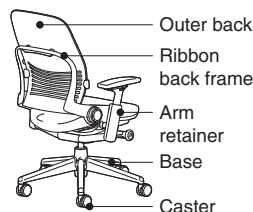

Polished aluminum package is available on black chairs only. Polished aluminum is applied to ribbon back frame, base, and casters. Stools and Plus models are not available with this package.

Arms

- Black only

Column and foot ring on stools

- 7207 Black only

All Steelcase seating with standard upholstery fabrics complies with requirements of the State of California Technical Bulletin 117-2013. All standard seating is labeled to be in compliance with California 117-2013.

Programs & Services

▶ See the *Surface Materials Reference Manual* for further detail about programs and services offered for seating.

The Customer's Own Material (COM) Program

offers the opportunity for customers to select fabrics that are not offered through the standard Steelcase surface materials program for use on Steelcase products. Through the COM program, Steelcase will test your materials for application on Steelcase products. Once approved, you can place your order. Steelcase will facilitate the entire ordering process and give you a production schedule. Steelcase will order the COM fabric directly from the textile manufacturer. For up-to-date information regarding fabric test results for all COM fabrics and details regarding yardage requirements for most Seating lines, visit the COM website. To locate the COM website:

- Visit www.steelcase.com

Soil retardants are treatments that provide long-term soil and stain resistance to a fabric without affecting the shade or the integrity of the fabric. The following Steelcase Textiles are available pre-treated with soil retardant. (You do not need to select the soil-retardant option for these fabrics and incur the upcharge.)

- Jacks
- Link
- Spyder

For information on soil retardant fabrics on Select Surfaces, please refer to the *Surface Materials Reference Manual*.

Soil-retardant treatment is available on all other seating fabrics at an additional upcharge per seating unit. To order this option, please select "Soil-Retardant Treatment" under "Optional Accessories."

For soil-retardant treatment on COMs, please select "Soil-Retardant Treatment" under "Optional Accessories." Minimums or additional yardage may be required. Please contact the vendor directly for specific information.

Extended lead times may be necessary for this service.

Contact your Steelcase Solutions Fulfillment Team Representative at 1.888.STEELCASE (1.888.783.3522) or send an email to lineone@steelcase.com.

Fire Codes

▶ See pages 462 for upholstery fabrics available for use with FCS modification.

Steelcase offers Fire Code Seating modification (FCS) on some seating models. The most rigorous fire codes in the nation have been developed in California, and the Steelcase FCS modification is designed to meet those codes. Fire Code Seating (FCS) indicates that a product is constructed to meet the strict fire code requirements of high public occupancy areas such as theaters, meeting rooms, and lobbies. The FCS standards will meet the State of California Bureau of Electronic and Appliance Repair, Home Furnishings, and Thermal Insulation Technical Bulletin 133 (Cal TB 133). Boston adopted the California Bureau of Electronic and Appliance Repair, Home Furnishings, and Thermal Insulation Technical Bulletin TB 133 test standard in 1992.

Local codes may have special requirements for upholstery.

Resources

Printed Materials

- ▶ Leap Brochure (11-0002334)
- ▶ Humantech Case Study (03-0003715)
- ▶ Leap Productivity and Health Impact Study (03-0003716)

Online Resources

- ▶ Interactive User Guide available on www.steelcase.com
- ▶ Leap mini-site (download) available on village.steelcase.com or viewable on www.steelcase.com.
- ▶ Model sales conversation available on village.steelcase.com
- ▶ Leap User Guide available on www.steelcase.com
- ▶ Adjustability video available on www.steelcase.com
- ▶ Leap White Paper Packet available on village.steelcase.com
- ▶ Environmental profiles available on www.steelcase.com/sustainability

Dimensions

▶ Page 48

Leap Upholstery

Leap 462 Series

What Is It?

Fabric, leather, or vinyl-covered back and seat, 3D Knit back.

Fabric

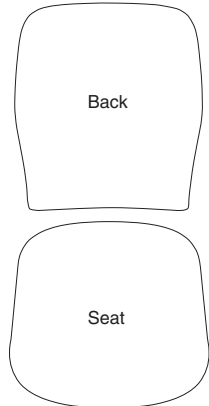

Leather, Vinyl, and Select Fabrics

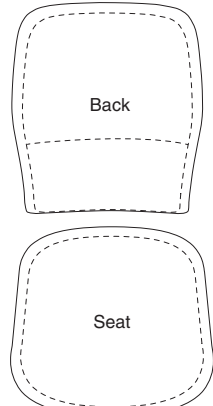

3D Knit Back

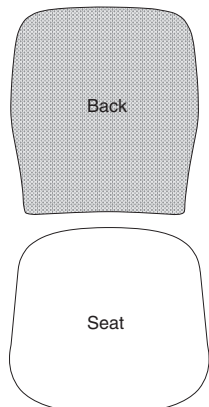

Stitched seams are included on the back cushion and seat cushion of the following:

- Leather
- Customer's Own Leather (COL)
- Vinyl
- Select Customer's Own Material/Vinyl (COM)

Pattern alignment at the lumbar seam cannot be guaranteed.

3D Knit back is made up of three layers: the 3D Knit, a solid fabric that matches the 3D Knit color, and the polyester cushion that provides exceptional comfort. The seat on these models can be specified with Cogent: Connect fabric colors to match the 3D Knit color, or in any other material.

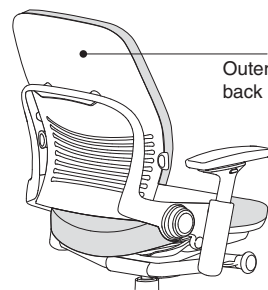

Plastic outer back is fully exposed.

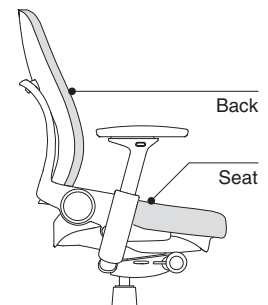

Seat and back cushions can be removed and replaced if damaged.

Dimensions

Leap 462 Series

Features	Overall Depth	Width	Height	Seat Depth	Functional Seat Depth	Seat Width	Seat Height from Floor	Ring Height from Floor	Back Width	Back Height from Seat
Leap 462 Series										
Work Chairs										
Adjustable Seat Depth	21 ³ / ₄ " to 24 ³ / ₄ "	27"	38 ¹ / ₂ " to 43 ¹ / ₂ "	19"	15 ³ / ₄ " to 18 ³ / ₄ "	19 ¹ / ₄ "	15 ¹ / ₂ " to 20 ¹ / ₂ "	N.A.	18"	25"
Stools										
Adjustable Seat Depth	21 ³ / ₄ " to 24 ³ / ₄ "	27"	46" to 54"	19"	15 ³ / ₄ " to 18 ³ / ₄ "	19 ¹ / ₄ "	22" to 30"	N.A.	18"	25"
Plus Work Chairs										
Adjustable Seat Depth	21 ³ / ₄ " to 24 ³ / ₄ "	31 ³ / ₄ "	38 ³ / ₄ " to 42 ¹ / ₂ "	20 ¹ / ₂ "	16 ³ / ₄ " to 18 ³ / ₄ "	22 ³ / ₄ "	15 ¹ / ₂ " to 19 ¹ / ₂ "	6" to 18"	20"	24 ¹ / ₂ "

Dimensions were measured with BIFMA CMD (chair-measuring device).

****Arm width adjustment** is 15"-20", (19³/₄"-24³/₄" for Leap Plus). Arm pivot adjustment adds 2¹/₄" to the minimum width providing a total of 12³/₄"-20" of width between the arms.

• Back Lumbar Height	• Lumbar Flex Zone	• Width Between Arms	• Arm to Floor	• Arm Height from Seat	• Arm Cap Pivot Range	• Seat Pan Angle	• Angle Between Seat and Back	• Headrest Height Adjustment Range
Work Chairs								
5¼" to 10¼"	5¼" to 10¼"	12¾" to 20"***	22" to 31"	7" to 11"	30°	-1° to 3°	96° to 120°	2¼"
Stools								
5¼" to 10¼"	5¼" to 10¼"	12¾" to 20"***	29" to 41"	7" to 11"	30°	-1° to 3°	96° to 120°	N.A.
Plus Work Chairs								
6½" to 11½"	11¼" to 16¼"	17½" to 24¾"***	22" to 30"	7¼" to 11¼"	30"	0° to 4°	97° to 114°	N.A.

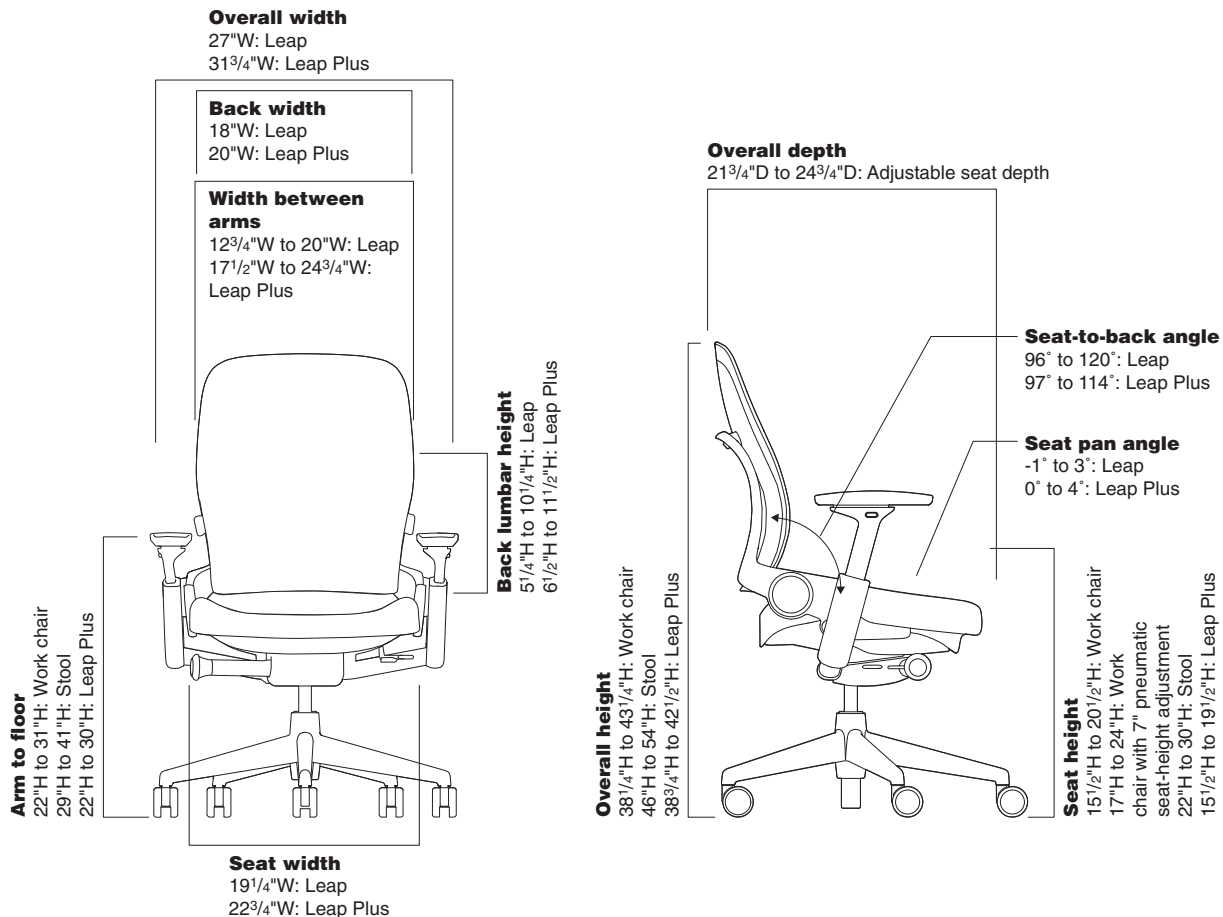

Leap 462 Series Work Chair

Upholstery on Back and Seat

SIN 711.18



► Need help?
Product details,
page 44

Standard Includes

- Upper back force
- 5" pneumatic seat-height adjustment
- Variable back stop
- Lower back firmness
- Rectilinear independent height-, width-, pivot-, and depth-adjustable arms and soft arm caps, if selected: black plastic
- Frame, seat shell, outer back, and five-arm base: plastic
- 3" seat depth adjustment
- Passive seat edge angle
- Adjustable lumbar
- Standard upholstery design: fabric price group 1
- 2½"-diameter, hard-composition, dual-wheel casters: black

Required to Specify

- 1 Style number
 - 2 Plastic color for frame, seat shell, outer back, and base
 - 3 Fabric color number for upholstery on seat and back
 - 4 Options, if selected (see below)
- See *Surface Materials*, page 432.

Tip: Leather and vinyl upcharges are in addition to sewn upholstery upcharge.

*Tip: Select COMs require sewn application with an additional upcharge. Specify with an **S** suffix.*

*Tip: Suffixes other than **K** for contrasting fabric, will be added in alphabetical order when specifying options. The contrasting fabric suffix, **K**, will always be at the end of the style number.*

	Options	Price	Required to Specify
Surface Materials	Upholstery on seat and back		
	• Fabric price group 1	No cost	Specify fabric color number.
	• Fabric price group 2	+\$ 26	Specify fabric color number.
	• Fabric price group 3	+\$ 48	Specify fabric color number.
	• Fabric price group 4	+\$ 68	Specify fabric color number.
	• Fabric price group 5	+\$ 85	Specify fabric color number.
	• Fabric price group 6	+\$106	Specify fabric color number.
	• Fabric price group 7	+\$121	Specify fabric color number.
	• Fabric price group 8	+\$153	Specify fabric color number.
	• Fabric price group 9	+\$188	Specify fabric color number.
• Fabric price group 10	+\$213	Specify fabric color number.	
• Steelcase leather upholstery	+\$630	Specify fabric color number. Add suffix S to the style number and specify leather color number.	
• Select Surfaces leather price group 1	+\$630	Add suffix S to the style number and specify Select Surfaces leather price group 1. ► See <i>Surface Materials Reference Manual</i> . Add suffix S to the style number and specify Elmosoft leather color number.	
• Elmosoft leather upholstery	+\$742	Add suffix S to the style number and specify Elmosoft leather color number.	
• Select Surfaces leather price group 2	+\$742	Add suffix S to the style number and specify Select Surfaces leather price group 2. ► See <i>Surface Materials Reference Manual</i> . Add suffix S to the style number and specify vinyl color number.	
• Steelcase vinyl	+\$ 26	► See <i>Surface Materials Reference Manual</i> to specify.	
• Customer's Own Material (COM)	No cost	► See <i>Surface Materials Reference Manual</i> to specify.	
• Customer's Own Leather (COL)	+\$277	Add suffix S to the style number and specify leather color number.	
	Sewn upholstery		
	• Sewn upholstery on chair	+\$ 77	Add suffix S to the style number.
	Contrasting upholstery on seat and back		
	• Contrasting fabrics	+\$ 31	Add suffix K to the style number and specify fabric color numbers.

► Options, continued on next page

► Detailed dimensions,
page 48

► Options, continued from previous page

Options	Price	Required to Specify
Surface Materials, continued		
Contrasting upholstery on seat		
• Fabric price group 1	No cost	Specify fabric color number.
• Fabric price group 2	+\$ 10	Specify fabric color number.
• Fabric price group 3	+\$ 26	Specify fabric color number.
• Fabric price group 4	+\$ 35	Specify fabric color number.
• Fabric price group 5	+\$ 42	Specify fabric color number.
• Fabric price group 6	+\$ 51	Specify fabric color number.
• Fabric price group 7	+\$ 62	Specify fabric color number.
• Fabric price group 8	+\$ 77	Specify fabric color number.
• Fabric price group 9	+\$ 94	Specify fabric color number.
• Fabric price group 10	+\$109	Specify fabric color number.
• Steelcase leather upholstery	+\$315	Add suffix S to the style number and specify leather color number.
• Select Surfaces leather price group 1	+\$315	Add suffix S to the style number and specify leather color number.
• Elmosoft leather upholstery	+\$371	Add suffix S to the style number and specify leather color number.
• Select Surfaces leather price group 2	+\$371	Add suffix S to the style number and specify leather color number.
• Steelcase vinyl	+\$ 10	Add suffix S to the style number and specify vinyl color number.
• Customer's Own Material (COM)	No cost	► See <i>Surface Materials Reference Manual</i> .
• Customer's Own Leather (COL)	+\$138	Add suffix S to the style number and specify leather color number.
Contrasting upholstery on back		
• Fabric price group 1	No cost	Specify fabric color number.
• Fabric price group 2	+\$ 16	Specify fabric color number.
• Fabric price group 3	+\$ 22	Specify fabric color number.
• Fabric price group 4	+\$ 33	Specify fabric color number.
• Fabric price group 5	+\$ 43	Specify fabric color number.
• Fabric price group 6	+\$ 55	Specify fabric color number.
• Fabric price group 7	+\$ 59	Specify fabric color number.
• Fabric price group 8	+\$ 76	Specify fabric color number.
• Fabric price group 9	+\$ 94	Specify fabric color number.
• Fabric price group 10	+\$104	Specify fabric color number.
• Steelcase leather upholstery	+\$315	Add suffix S to the style number and specify leather color number.
• Select Surfaces leather price group 1	+\$315	Add suffix S to the style number and specify leather color number.
• Elmosoft leather upholstery	+\$371	Add suffix S to the style number and specify leather color number.
• Select Surfaces leather price group 2	+\$371	Add suffix S to the style number and specify leather color number.
• Steelcase vinyl	+\$ 16	Add suffix S to the style number and specify vinyl color number.
• Customer's Own Material (COM)	No cost	► See <i>Surface Materials Reference Manual</i> .
• Customer's Own Leather (COL)	+\$139	Add suffix S to the style number and specify leather color number.
Fire Code Seating (FCS)	+\$ 77	Add suffix F to the style number.
Soil-retardant treatment	+\$ 25	Specify <i>with soil-retardant treatment</i> .
Polished aluminum package		
• Polished aluminum package on chairs with arms and 6205 Black frame finish	+\$469	Add suffix C to the style number.
Platinum		
• On frame, base, arm retainer, and outer back	+\$ 48	Specify <i>with 6249 Platinum</i> .

► Options, continued on next page

Tip: Leather and vinyl upcharges are in addition to sewn upholstery upcharge.

Leap 462 Series Work Chair, Upholstery on Back and Seat, continued

SIN 711.18

► Options, continued from previous page

	Options	Price	Required to Specify
Arms	• Height-adjustable arms, soft arm caps	-\$ 90	Specify with height-adjustable arms.
	• Armless	-\$282	Specify without arms.
Headrest	• Headrest	+\$231	Specify with headrest.
Seat Height	• 7" pneumatic seat-height	+\$ 58	Specify with 7" pneumatic seat-height adjustment.
Lumbar	• Without lumbar	-\$ 57	Specify without lumbar.
Casters	• Soft, dark grey treaded, dual-wheel casters for use on hard floors	+\$ 25	Specify with soft roll-control casters.
Glides	• Glides: plastic	+\$ 25	Specify with glides.

Tip: Plastic shell on headrest is available in black only.

Tip: Glides are not available on chairs with polished aluminum package.

Specification Information



• Style Number	• Base Price
46216179	\$1543

Leap 462 Series Work Chair

3D Knit on Back with Upholstery on Seat

SIN 711.18



Standard Includes		Required to Specify
<ul style="list-style-type: none"> ▶ Need help? Product details, page 44 	<ul style="list-style-type: none"> • Upper back force • 5" pneumatic seat-height adjustment • Variable back stop • Lower back firmness • Rectilinear independent height-, width-, pivot-, and depth-adjustable arms and soft arm caps, if selected: black plastic • Frame, seat shell, outer back, and five-arm base: plastic • 3" seat depth adjustment • Passive seat edge angle • Adjustable lumbar • 3D Knit on back only • Standard upholstery design on seat: fabric price group 1 • 2½"-diameter, hard-composition, dual-wheel casters: black 	<ol style="list-style-type: none"> 1 Style number 2 Plastic color for frame, seat shell, outer back, and base 3 3D Knit color for back 4 Fabric color number for upholstery on seat 5 Options, if selected (see below) <ul style="list-style-type: none"> ▶ See <i>Surface Materials</i>, page 432.

Options	Price	Required to Specify
<p>Surface Materials</p> <p>Upholstery</p> <ul style="list-style-type: none"> • Fabric price group 1 • Fabric price group 2 • Fabric price group 3 • Fabric price group 4 • Fabric price group 5 • Fabric price group 6 • Fabric price group 7 • Fabric price group 8 • Fabric price group 9 • Fabric price group 10 • Steelcase leather upholstery <ul style="list-style-type: none"> • Select Surfaces leather price group 1 <ul style="list-style-type: none"> • Elmosoft leather upholstery <ul style="list-style-type: none"> • Select Surfaces leather price group 2 <ul style="list-style-type: none"> • Steelcase vinyl <ul style="list-style-type: none"> • Customer's Own Material (COM) <ul style="list-style-type: none"> • Customer's Own Leather (COL) 	<p>No cost</p> <p>+\$ 10</p> <p>+\$ 26</p> <p>+\$ 35</p> <p>+\$ 42</p> <p>+\$ 51</p> <p>+\$ 62</p> <p>+\$ 77</p> <p>+\$ 94</p> <p>+\$109</p> <p>+\$313</p> <p>+\$313</p> <p>+\$367</p> <p>+\$367</p> <p>+\$ 10</p> <p>No cost</p> <p>+\$135</p> <p>+\$ 77</p> <p>+\$ 25</p> <p>+\$ 41</p> <p>+\$469</p> <p>+\$ 48</p>	<p>Specify fabric color number.</p> <p>Specify fabric color number.</p> <p>Specify fabric color number.</p> <p>Specify fabric color number.</p> <p>Specify fabric color number.</p> <p>Specify fabric color number.</p> <p>Specify fabric color number.</p> <p>Specify fabric color number.</p> <p>Specify fabric color number.</p> <p>Specify fabric color number.</p> <p>Add suffix S to the style number and specify leather color number.</p> <p>Add suffix S to the style number and specify Select Surfaces leather price group 1.</p> <p>▶ See <i>Surface Materials Reference Manual</i>. Add suffix S to the style number and specify Elmosoft leather color number.</p> <p>Add suffix S to the style number and specify Select Surfaces leather price group 2.</p> <p>▶ See <i>Surface Materials Reference Manual</i>. Add suffix S to the style number and specify vinyl color number.</p> <p>▶ See <i>Surface Materials Reference Manual</i> to specify.</p> <p>Add suffix S to the style number and specify leather color number.</p> <p>Add suffix F to the style number.</p> <p>Specify <i>with soil-retardant treatment</i>.</p> <p>Add suffix S to the style number.</p> <p>Add suffix C to the style number.</p> <p>Specify <i>with 6249 Platinum</i>.</p>
<p>Fire Code Seating (FCS)</p> <p>Soil-retardant treatment</p> <p>Sewn upholstery</p> <ul style="list-style-type: none"> • Sewn upholstery on chair <p>Polished aluminum package</p> <ul style="list-style-type: none"> • Polished aluminum package on chairs with arms and 6205 Black frame finish <p>Platinum</p> <ul style="list-style-type: none"> • On frame, base, arm retainer, and outer back 	<p>+\$ 77</p> <p>+\$ 25</p> <p>+\$ 41</p> <p>+\$469</p> <p>+\$ 48</p>	<p>Add suffix F to the style number.</p> <p>Specify <i>with soil-retardant treatment</i>.</p> <p>Add suffix S to the style number.</p> <p>Add suffix C to the style number.</p> <p>Specify <i>with 6249 Platinum</i>.</p>

▶ Options, continued on next page

Tip: Always add suffixes in alphabetical order when specifying options to Leap seating.

Tip: Leather and vinyl upcharges are in addition to sewn upholstery upcharge.

Tip: Select COMs require sewn application with an additional upcharge. Specify with an **S** suffix.

Tip: Fire Code Seating (FCS) option is available with certain upholstery fabric choices only.

▶ Pages 462

Tip: Glides are not available on chairs with polished aluminum package.

▶ Detailed dimensions, page 48

SIN 711.18

► Options, continued from previous page

	Options	Price	Required to Specify
Arms	• Height-adjustable arms, soft arm caps	-\$ 90	Specify with height-adjustable arms.
	• Armless	-\$282	Specify without arms.
Headrest	• Headrest	+\$231	Specify with headrest.
Seat Height	• 7" pneumatic seat-height adjustment	+\$ 58	Specify with 7" pneumatic seat-height adjustment.
Lumbar	• Without lumbar	-\$ 57	Specify without lumbar.
Casters	• Soft, dark grey treaded, dual-wheel roll-control casters for use on hard floors	+\$ 25	Specify with soft roll-control casters.
Glides	• Glides: plastic	+\$ 25	Specify with glides.

Tip: Plastic shell on headrest is available in black only.

Specification Information



• **Style Number** • **Base Price**

46216189 \$1601

Leap 462 Series Stool

Upholstery on Back and Seat

SIN 711.18

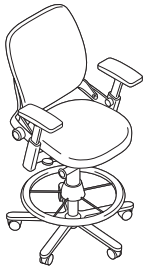

► Need help?
Product details,
page 44

Standard Includes

- Upper back force
- 8" pneumatic seat-height adjustment
- Variable back stop
- Lower back firmness
- Passive seat edge angle
- Rectilinear independent height-, width-, pivot-, and depth-adjustable arms and soft arm caps, if selected: black plastic
- Frame, seat shell, outer back, and five-arm base: plastic
- 3" seat depth adjustment
- Column and 4" adjustable foot ring: black
- Standard upholstery design: fabric price group 1
- 2"-diameter, hard-composition, dual-wheel casters: black

Required to Specify

- 1 Style number
 - 2 Plastic color for frame, seat shell, outer back, and base
 - 3 Fabric color number for upholstery on seat and back
 - 4 Options, if selected (see below)
- See *Surface Materials*, page 432

Tip: Leather and vinyl upcharges are in addition to sewn upholstery upcharge.

*Tip: Select COMs require sewn application with an additional upcharge. Specify with an **S** suffix.*

*Tip: Suffixes other than **K** for contrasting fabric, will be added in alphabetical order when specifying options. The contrasting fabric suffix, **K**, will always be at the end of the style number.*

► Detailed dimensions, page 48

	Options	Price	Required to Specify
Surface Materials	Upholstery on seat and back		
	• Fabric price group 1	No cost	Specify fabric color number.
	• Fabric price group 2	+\$ 26	Specify fabric color number.
	• Fabric price group 3	+\$ 48	Specify fabric color number.
	• Fabric price group 4	+\$ 68	Specify fabric color number.
	• Fabric price group 5	+\$ 85	Specify fabric color number.
	• Fabric price group 6	+\$106	Specify fabric color number.
	• Fabric price group 7	+\$121	Specify fabric color number.
	• Fabric price group 8	+\$153	Specify fabric color number.
	• Fabric price group 9	+\$188	Specify fabric color number.
	• Fabric price group 10	+\$213	Specify fabric color number.
	• Steelcase leather upholstery	+\$630	Add suffix S to the style number and specify leather color number.
	• Select Surfaces leather price group 1	+\$630	Add suffix S to the style number and specify Select Surfaces leather price group 1.
	• Elmosoft leather upholstery	+\$742	► See <i>Surface Materials Reference Manual</i> . Add suffix S to the style number and specify Elmosoft leather color number.
• Select Surfaces leather price group 2	+\$742	Add suffix S to the style number and specify Select Surfaces leather price group 2.	
• Steelcase vinyl	+\$ 26	► See <i>Surface Materials Reference Manual</i> . Add suffix S to the style number and specify vinyl color number.	
• Customer's Own Material (COM)	No cost	► See <i>Surface Materials Reference Manual</i> to specify.	
• Customer's Own Leather (COL)	+\$277	Add suffix S to the style number and specify leather color number.	
	Platinum		
	• On frame, base, arm retainer, and outer back	+\$ 48	Specify with 6249 Platinum.
	Sewn upholstery		
	• Sewn upholstery on chair	+\$ 77	Add suffix S to the style number.
	Contrasting upholstery on seat and back		
	• Contrasting fabrics	+\$ 31	Add suffix K to the style number and specify fabric color numbers.
	Contrasting upholstery on seat		
	• Fabric price group 1	No cost	Specify fabric color number.
	• Fabric price group 2	+\$ 10	Specify fabric color number.
	• Fabric price group 3	+\$ 26	Specify fabric color number.
	• Fabric price group 4	+\$ 35	Specify fabric color number.
	• Fabric price group 5	+\$ 42	Specify fabric color number.
	• Fabric price group 6	+\$ 51	Specify fabric color number.
	• Fabric price group 7	+\$ 62	Specify fabric color number.
	• Fabric price group 8	+\$ 77	Specify fabric color number.
	• Fabric price group 9	+\$ 94	Specify fabric color number.
	• Fabric price group 10	+\$109	Specify fabric color number.

► Options, continued on next page

SIN 711.18

► Options, continued from previous page

Options	Price	Required to Specify
Surface Materials, continued		
• Steelcase leather upholstery	+\$315	Add suffix S to the style number and specify leather color number.
• Select Surfaces leather price group 1	+\$315	Add suffix S to the style number and specify leather color number.
• Elmosoft leather upholstery	+\$371	Add suffix S to the style number and specify leather color number.
• Select Surfaces leather price group 2	+\$371	Add suffix S to the style number and specify leather color number.
• Steelcase vinyl	+\$ 10	Add suffix S to the style number and specify vinyl color number.
• Customer's Own Material (COM)	No cost	► See <i>Surface Materials Reference Manual</i> .
• Customer's Own Leather (COL)	+\$138	Add suffix S to the style number and specify leather color number.
Contrasting upholstery on back		
• Fabric price group 1	No cost	Specify fabric color number.
• Fabric price group 2	+\$ 16	Specify fabric color number.
• Fabric price group 3	+\$ 22	Specify fabric color number.
• Fabric price group 4	+\$ 33	Specify fabric color number.
• Fabric price group 5	+\$ 43	Specify fabric color number.
• Fabric price group 6	+\$ 55	Specify fabric color number.
• Fabric price group 7	+\$ 59	Specify fabric color number.
• Fabric price group 8	+\$ 76	Specify fabric color number.
• Fabric price group 9	+\$ 94	Specify fabric color number.
• Fabric price group 10	+\$104	Specify fabric color number.
• Steelcase leather upholstery	+\$315	Add suffix S to the style number and specify leather color number.
• Select Surfaces leather price group 1	+\$315	Add suffix S to the style number and specify leather color number.
• Elmosoft leather upholstery	+\$371	Add suffix S to the style number and specify leather color number.
• Select Surfaces leather price group 2	+\$371	Add suffix S to the style number and specify leather color number.
• Steelcase vinyl	+\$ 16	Add suffix S to the style number and specify vinyl color number.
• Customer's Own Material (COM)	No cost	► See <i>Surface Materials Reference Manual</i> .
• Customer's Own Leather (COL)	+\$139	Add suffix S to the style number and specify leather color number.
Soil-retardant treatment	+\$ 25	Specify <i>with soil-retardant treatment</i> .
Fire Code Seating (FCS)	+\$ 77	Add suffix F to the style number.
Arms		
• Height-adjustable arms, soft arm caps	-\$ 90	Specify <i>with height-adjustable arms</i> .
• Armless	-\$282	Specify <i>without arms</i> .
Lumbar		
• Without lumbar	-\$ 57	Specify <i>without lumbar</i> .
Casters		
• Soft, dark grey treaded, dual-wheel roll-control casters for use on hard floors	+\$ 25	Specify <i>with soft roll-control casters</i> .
Glides		
• Glides: plastic	+\$ 25	Specify <i>with glides</i> .

► Specification Information, on next page

Tip: Leather and vinyl upcharges are in addition to sewn upholstery upcharge.

Tip: Fire Code Seating (FCS) option is available with certain upholstery fabric choices only.

► Page 462

Tip: Glides are not available on chairs with polished aluminum package.

SIN 711.18

► Options, on previous page

Specification Information



• Style • Number	• Base • Price
46267179	\$1779

SIN 711.18

Leap 462 Series Stool

3D Knit on Back with Upholstery on Seat

SIN 711.18

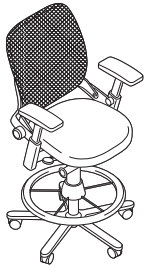

Standard Includes	Required to Specify
<ul style="list-style-type: none"> ▶ Need help? Product details, page 44 • Upper back force • 8" pneumatic seat-height adjustment • Variable back stop • Lower back firmness • Passive seat edge angle • Rectilinear independent height-, width-, pivot-, and depth-adjustable arms and soft arm caps, if selected: black plastic • Frame, seat shell, outer back, and five-arm base: plastic • Column and 4" adjustable foot ring: black • 3D Knit on back • 3" seat depth adjustment • Adjustable lumbar • Standard upholstery design on seat: fabric price group 1 • 2"-diameter, hard-composition, dual-wheel casters: black 	<ol style="list-style-type: none"> 1 Style number 2 Plastic color for frame, seat shell, outer back, and base 3 3D Knit color for back 4 Fabric color number for upholstery on seat 5 Options, if selected (see below) <p>▶ See <i>Surface Materials</i>, page 432</p>

Options	Price	Required to Specify																																																																																																				
<table border="0" style="width: 100%;"> <tr> <td style="width: 30%;">Surface Materials</td> <td>Upholstery</td> <td></td> </tr> <tr> <td>• Fabric price group 1</td> <td>No cost</td> <td>Specify fabric color number.</td> </tr> <tr> <td>• Fabric price group 2</td> <td>+\$ 10</td> <td>Specify fabric color number.</td> </tr> <tr> <td>• Fabric price group 3</td> <td>+\$ 26</td> <td>Specify fabric color number.</td> </tr> <tr> <td>• Fabric price group 4</td> <td>+\$ 35</td> <td>Specify fabric color number.</td> </tr> <tr> <td>• Fabric price group 5</td> <td>+\$ 42</td> <td>Specify fabric color number.</td> </tr> <tr> <td>• Fabric price group 6</td> <td>+\$ 51</td> <td>Specify fabric color number.</td> </tr> <tr> <td>• Fabric price group 7</td> <td>+\$ 62</td> <td>Specify fabric color number.</td> </tr> <tr> <td>• Fabric price group 8</td> <td>+\$ 77</td> <td>Specify fabric color number.</td> </tr> <tr> <td>• Fabric price group 9</td> <td>+\$ 94</td> <td>Specify fabric color number.</td> </tr> <tr> <td>• Fabric price group 10</td> <td>+\$109</td> <td>Specify fabric color number.</td> </tr> <tr> <td>• Steelcase leather upholstery</td> <td>+\$313</td> <td>Add suffix S to the style number and specify leather color number.</td> </tr> <tr> <td>• Select Surfaces leather price group 1</td> <td>+\$313</td> <td>Add suffix S to the style number and specify Select Surfaces leather price group 1.</td> </tr> <tr> <td></td> <td></td> <td>▶ See <i>Surface Materials Reference Manual</i></td> </tr> <tr> <td>• Elmosoft leather upholstery</td> <td>+\$367</td> <td>Add suffix S to the style number and specify Elmosoft leather color number.</td> </tr> <tr> <td>• Select Surfaces leather price group 2</td> <td>+\$367</td> <td>Add suffix S to the style number and specify Select Surfaces leather price group 2.</td> </tr> <tr> <td></td> <td></td> <td>▶ See <i>Surface Materials Reference Manual</i></td> </tr> <tr> <td>• Steelcase vinyl</td> <td>+\$ 10</td> <td>Add suffix S to the style number and specify vinyl color number.</td> </tr> <tr> <td></td> <td></td> <td>▶ See <i>Surface Materials Reference Manual</i></td> </tr> <tr> <td>• Customer's Own Material (COM)</td> <td>No cost</td> <td>Add suffix S to the style number and specify leather color number.</td> </tr> <tr> <td>• Customer's Own Leather (COL)</td> <td>+\$135</td> <td></td> </tr> <tr> <td colspan="2">Fire Code Seating (FCS)</td> <td>+\$ 77</td> <td>Add suffix F to the style number.</td> </tr> <tr> <td colspan="2">Soil-retardant treatment</td> <td>+\$ 25</td> <td>Specify <i>with soil-retardant treatment</i>.</td> </tr> <tr> <td colspan="2">Sewn upholstery</td> <td></td> <td></td> </tr> <tr> <td>• Sewn upholstery on chair</td> <td>+\$ 41</td> <td>Add suffix S to the style number.</td> </tr> <tr> <td colspan="2">Platinum</td> <td></td> <td></td> </tr> <tr> <td>• On frame, base, arm retainer, and outer back</td> <td>+\$ 48</td> <td>Specify <i>with 6249 Platinum</i>.</td> </tr> <tr> <td>Arms</td> <td></td> <td></td> <td></td> </tr> <tr> <td>• Height-adjustable arms, soft arm caps</td> <td>-\$ 90</td> <td>Specify <i>with height-adjustable arms</i>.</td> </tr> <tr> <td>• Armless</td> <td>-\$282</td> <td>Specify <i>without arms</i>.</td> </tr> <tr> <td>Lumbar</td> <td></td> <td></td> <td></td> </tr> <tr> <td>• Without lumbar</td> <td>-\$ 57</td> <td>Specify <i>without lumbar</i>.</td> </tr> </table>	Surface Materials	Upholstery		• Fabric price group 1	No cost	Specify fabric color number.	• Fabric price group 2	+\$ 10	Specify fabric color number.	• Fabric price group 3	+\$ 26	Specify fabric color number.	• Fabric price group 4	+\$ 35	Specify fabric color number.	• Fabric price group 5	+\$ 42	Specify fabric color number.	• Fabric price group 6	+\$ 51	Specify fabric color number.	• Fabric price group 7	+\$ 62	Specify fabric color number.	• Fabric price group 8	+\$ 77	Specify fabric color number.	• Fabric price group 9	+\$ 94	Specify fabric color number.	• Fabric price group 10	+\$109	Specify fabric color number.	• Steelcase leather upholstery	+\$313	Add suffix S to the style number and specify leather color number.	• Select Surfaces leather price group 1	+\$313	Add suffix S to the style number and specify Select Surfaces leather price group 1.			▶ See <i>Surface Materials Reference Manual</i>	• Elmosoft leather upholstery	+\$367	Add suffix S to the style number and specify Elmosoft leather color number.	• Select Surfaces leather price group 2	+\$367	Add suffix S to the style number and specify Select Surfaces leather price group 2.			▶ See <i>Surface Materials Reference Manual</i>	• Steelcase vinyl	+\$ 10	Add suffix S to the style number and specify vinyl color number.			▶ See <i>Surface Materials Reference Manual</i>	• Customer's Own Material (COM)	No cost	Add suffix S to the style number and specify leather color number.	• Customer's Own Leather (COL)	+\$135		Fire Code Seating (FCS)		+\$ 77	Add suffix F to the style number.	Soil-retardant treatment		+\$ 25	Specify <i>with soil-retardant treatment</i> .	Sewn upholstery				• Sewn upholstery on chair	+\$ 41	Add suffix S to the style number.	Platinum				• On frame, base, arm retainer, and outer back	+\$ 48	Specify <i>with 6249 Platinum</i> .	Arms				• Height-adjustable arms, soft arm caps	-\$ 90	Specify <i>with height-adjustable arms</i> .	• Armless	-\$282	Specify <i>without arms</i> .	Lumbar				• Without lumbar	-\$ 57	Specify <i>without lumbar</i> .
Surface Materials	Upholstery																																																																																																					
• Fabric price group 1	No cost	Specify fabric color number.																																																																																																				
• Fabric price group 2	+\$ 10	Specify fabric color number.																																																																																																				
• Fabric price group 3	+\$ 26	Specify fabric color number.																																																																																																				
• Fabric price group 4	+\$ 35	Specify fabric color number.																																																																																																				
• Fabric price group 5	+\$ 42	Specify fabric color number.																																																																																																				
• Fabric price group 6	+\$ 51	Specify fabric color number.																																																																																																				
• Fabric price group 7	+\$ 62	Specify fabric color number.																																																																																																				
• Fabric price group 8	+\$ 77	Specify fabric color number.																																																																																																				
• Fabric price group 9	+\$ 94	Specify fabric color number.																																																																																																				
• Fabric price group 10	+\$109	Specify fabric color number.																																																																																																				
• Steelcase leather upholstery	+\$313	Add suffix S to the style number and specify leather color number.																																																																																																				
• Select Surfaces leather price group 1	+\$313	Add suffix S to the style number and specify Select Surfaces leather price group 1.																																																																																																				
		▶ See <i>Surface Materials Reference Manual</i>																																																																																																				
• Elmosoft leather upholstery	+\$367	Add suffix S to the style number and specify Elmosoft leather color number.																																																																																																				
• Select Surfaces leather price group 2	+\$367	Add suffix S to the style number and specify Select Surfaces leather price group 2.																																																																																																				
		▶ See <i>Surface Materials Reference Manual</i>																																																																																																				
• Steelcase vinyl	+\$ 10	Add suffix S to the style number and specify vinyl color number.																																																																																																				
		▶ See <i>Surface Materials Reference Manual</i>																																																																																																				
• Customer's Own Material (COM)	No cost	Add suffix S to the style number and specify leather color number.																																																																																																				
• Customer's Own Leather (COL)	+\$135																																																																																																					
Fire Code Seating (FCS)		+\$ 77	Add suffix F to the style number.																																																																																																			
Soil-retardant treatment		+\$ 25	Specify <i>with soil-retardant treatment</i> .																																																																																																			
Sewn upholstery																																																																																																						
• Sewn upholstery on chair	+\$ 41	Add suffix S to the style number.																																																																																																				
Platinum																																																																																																						
• On frame, base, arm retainer, and outer back	+\$ 48	Specify <i>with 6249 Platinum</i> .																																																																																																				
Arms																																																																																																						
• Height-adjustable arms, soft arm caps	-\$ 90	Specify <i>with height-adjustable arms</i> .																																																																																																				
• Armless	-\$282	Specify <i>without arms</i> .																																																																																																				
Lumbar																																																																																																						
• Without lumbar	-\$ 57	Specify <i>without lumbar</i> .																																																																																																				

▶ Options, continued on next page

Tip: Always add suffixes in alphabetical order when specifying options to Leap seating.

Tip: Leather and vinyl upcharges are in addition to sewn upholstery upcharge.

Tip: Select COMs require sewn application with an additional upcharge. Specify with an **S** suffix.

Tip: Fire Code Seating (FCS) option is available with certain upholstery fabric choices only.

▶ Pages 462

▶ Detailed dimensions, page 48

SIN 711.18

► **Options, continued from previous page**

	Options	Price	Required to Specify
Casters	<ul style="list-style-type: none"> Soft, dark grey treaded, dual-wheel roll-control casters for use on hard floors 	+\$25	Specify with <i>soft roll-control casters</i> .
Glides	<ul style="list-style-type: none"> Glides: plastic 	+\$25	Specify with <i>glides</i> .

Specification Information



• Style Number	• Base Price
46267189	\$1837

Leap 462 Series

Leap Plus 462 Series Work Chair

Upholstery on Back and Seat

SIN 711.18

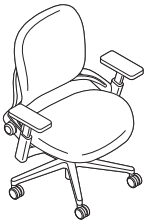

► Need help?
Product details,
page 44

Standard Includes

- Upper back force
- 4" pneumatic seat-height adjustment
- Variable back stop
- Lower back firmness
- Rectilinear independent height-, width-, pivot-, and depth-adjustable arms and soft arm caps, if selected: black plastic
- Frame, seat shell, outer back, and five-arm base: plastic
- 2" seat depth adjustment
- Adjustable lumbar
- Standard upholstery design: fabric price group 1
- 2½"-diameter, hard-composition, dual-wheel casters: black

Required to Specify

- 1 Style number
 - 2 Plastic color for frame, seat shell, outer back, and base
 - 3 Fabric color number for upholstery on seat and back
 - 4 Options, if selected (see below)
- See *Surface Materials*, page 432

Tip: Leather and vinyl upcharges are in addition to sewn upholstery upcharge.

Tip: Select COMs require sewn application with an additional upcharge. Specify with an **S** suffix.

Tip: Suffixes other than **K** for contrasting fabric, will be added in alphabetical order when specifying options. The contrasting fabric suffix, **K**, will always be at the end of the style number.

Options		Price	Required to Specify
Surface Materials	Upholstery on seat and back		
	• Fabric price group 1	No cost	Specify fabric color number.
	• Fabric price group 2	+\$ 26	Specify fabric color number.
	• Fabric price group 3	+\$ 48	Specify fabric color number.
	• Fabric price group 4	+\$ 68	Specify fabric color number.
	• Fabric price group 5	+\$ 85	Specify fabric color number.
	• Fabric price group 6	+\$106	Specify fabric color number.
	• Fabric price group 7	+\$121	Specify fabric color number.
	• Fabric price group 8	+\$153	Specify fabric color number.
	• Fabric price group 9	+\$188	Specify fabric color number.
	• Fabric price group 10	+\$213	Specify fabric color number.
	• Steelcase leather upholstery	+\$630	Add suffix S to the style number and specify leather color number.
	• Select Surfaces leather price group 1	+\$630	Add suffix S to the style number and specify Select Surfaces leather price group 1. ► See <i>Surface Materials Reference Manual</i> .
• Elmosoft leather upholstery	+\$742	Add suffix S to the style number and specify Elmosoft leather color number.	
• Select Surfaces leather price group 2	+\$742	Add suffix S to the style number and specify Select Surfaces leather price group 2. ► See <i>Surface Materials Reference Manual</i> .	
• Steelcase vinyl	+\$ 26	Add suffix S to the style number and specify vinyl color number.	
• Customer's Own Material (COM)	No cost	► See <i>Surface Materials Reference Manual</i> to specify.	
• Customer's Own Leather (COL)	+\$277	Add suffix S to the style number and specify leather color number.	
Sewn upholstery			
• Sewn upholstery on chair	+\$ 77	Add suffix S to the style number.	
Contrasting upholstery on seat and back			
• Contrasting fabrics	+\$ 31	Add suffix K to the style number and specify fabric color numbers.	
Contrasting upholstery on seat			
• Fabric price group 1	No cost	Specify fabric color number.	
• Fabric price group 2	+\$ 10	Specify fabric color number.	
• Fabric price group 3	+\$ 26	Specify fabric color number.	
• Fabric price group 4	+\$ 35	Specify fabric color number.	
• Fabric price group 5	+\$ 42	Specify fabric color number.	
• Fabric price group 6	+\$ 51	Specify fabric color number.	
• Fabric price group 7	+\$ 62	Specify fabric color number.	
• Fabric price group 8	+\$ 77	Specify fabric color number.	
• Fabric price group 9	+\$ 94	Specify fabric color number.	
• Fabric price group 10	+\$109	Specify fabric color number.	

► Options, continued on next page

► Detailed dimensions,
page 48

SIN 711.18

► Options, continued from previous page

Options	Price	Required to Specify
Surface Materials, continued		
Contrasting upholstery on seat, continued		
• Steelcase leather upholstery	+\$315	Add suffix S to the style number and specify leather color number.
• Select Surfaces leather price group 1	+\$315	Add suffix S to the style number and specify leather color number.
• Elmosoft leather upholstery	+\$371	Add suffix S to the style number and specify leather color number.
• Select Surfaces leather price group 2	+\$371	Add suffix S to the style number and specify leather color number.
• Steelcase vinyl	+\$ 10	Add suffix S to the style number and specify vinyl color number.
• Customer's Own Material (COM)	No cost	► See <i>Surface Materials Reference Manual</i> .
• Customer's Own Leather (COL)	+\$138	Add suffix S to the style number and specify leather color number.
Contrasting upholstery on back		
• Fabric price group 1	No cost	Specify fabric color number.
• Fabric price group 2	+\$ 16	Specify fabric color number.
• Fabric price group 3	+\$ 22	Specify fabric color number.
• Fabric price group 4	+\$ 33	Specify fabric color number.
• Fabric price group 5	+\$ 43	Specify fabric color number.
• Fabric price group 6	+\$ 55	Specify fabric color number.
• Fabric price group 7	+\$ 59	Specify fabric color number.
• Fabric price group 8	+\$ 76	Specify fabric color number.
• Fabric price group 9	+\$ 94	Specify fabric color number.
• Fabric price group 10	+\$104	Specify fabric color number.
• Steelcase leather upholstery	+\$315	Add suffix S to the style number and specify leather color number.
• Select Surfaces leather price group 1	+\$315	Add suffix S to the style number and specify leather color number.
• Elmosoft leather upholstery	+\$371	Add suffix S to the style number and specify leather color number.
• Select Surfaces leather price group 2	+\$371	Add suffix S to the style number and specify leather color number.
• Steelcase vinyl	+\$ 16	Add suffix S to the style number and specify vinyl color number.
• Customer's Own Material (COM)	No cost	► See <i>Surface Materials Reference Manual</i> .
• Customer's Own Leather (COL)	+\$139	Add suffix S to the style number and specify leather color number.
Soil-retardant treatment		
	+\$ 25	Specify with <i>soil-retardant treatment</i> .
Fire Code Seating (FCS)		
	+\$ 77	Add suffix F to the style number.
Platinum		
• On frame, base, arm retainer, and outer back	+\$ 48	Specify with <i>6249 Platinum</i> .
Arms		
• Height-adjustable arms, soft arm caps	-\$ 90	Specify with <i>height-adjustable arms</i> .
• Armless	-\$282	Specify <i>without arms</i> .
Seat Height		
• 5" pneumatic seat-height adjustment	+\$ 58	Specify with <i>5" pneumatic seat-height adjustment</i> .
Lumbar		
• Without lumbar	-\$ 57	Specify <i>without lumbar</i> .
Casters		
• Soft, dark grey treaded, dual-wheel roll-control casters for use on hard floors	+\$ 25	Specify with <i>soft roll-control casters</i> .
Glides		
• Glides: plastic	+\$ 25	Specify with <i>glides</i> .

Tip: Leather and vinyl upcharges are in addition to sewn upholstery upcharge.

Tip: Fire Code Seating (FCS) option is available with certain upholstery fabric choices only.
► Page 462

Tip: Glides are not available on chairs with polished aluminum package.

► Specification Information, on next page

SIN 711.18

► Options, on previous page

Specification Information



• Style • Number	• Base • Price
46296179	\$2322
.	.

Leap Plus 462 Series Work Chair

3D Knit on Back with Upholstery on Seat

SIN 711.18



Standard Includes	Required to Specify
<ul style="list-style-type: none"> ▶ Need help? Product details, page 44 • Upper back force • 4" pneumatic seat-height adjustment • Variable back stop • Lower back firmness • Rectilinear independent height-, width-, pivot-, and depth-adjustable arms and soft arm caps, if selected: black plastic • Frame, seat shell, outer back, and five-arm base: plastic • 2" seat depth adjustment • Adjustable lumbar • 3D Knit on back only • Standard upholstery design on seat: Fabric price group 1 • 2½"-diameter, hard-composition, dual-wheel casters: black 	<ul style="list-style-type: none"> 1 Style number 2 Plastic color for frame, seat shell, outer back, and base 3 3D Knit color for back 4 Fabric color number for upholstery on seat 5 Options, if selected (see below) ▶ See <i>Surface Materials</i>, page 432

Options	Price	Required to Specify																																										
<table border="0"> <tr> <td style="vertical-align: top;">Surface Materials</td> <td> <ul style="list-style-type: none"> • Fabric price group 1 • Fabric price group 2 • Fabric price group 3 • Fabric price group 4 • Fabric price group 5 • Fabric price group 6 • Fabric price group 7 • Fabric price group 8 • Fabric price group 9 • Fabric price group 10 • Steelcase leather upholstery • Select Surfaces leather price group 1 • Elmosoft leather upholstery • Select Surfaces leather price group 2 • Steelcase vinyl • Customer's Own Material (COM) • Customer's Own Leather (COL) </td> <td> <ul style="list-style-type: none"> No cost +\$ 10 +\$ 26 +\$ 35 +\$ 42 +\$ 51 +\$ 62 +\$ 77 +\$ 94 +\$109 +\$313 +\$313 +\$367 +\$367 +\$ 10 No cost +\$135 </td> <td> <ul style="list-style-type: none"> Specify fabric color number. Specify fabric color number. Specify fabric color number. Specify fabric color number. Specify fabric color number. Specify fabric color number. Specify fabric color number. Specify fabric color number. Specify fabric color number. Specify fabric color number. Specify fabric color number. Add suffix S to the style number and specify leather color number. Add suffix S to the style number and specify Select Surfaces leather price group 1. ▶ See <i>Surface Materials Reference Manual</i>. Add suffix S to the style number and specify Elmosoft leather color number. Add suffix S to the style number and specify Select Surfaces leather price group 2. ▶ See <i>Surface Materials Reference Manual</i>. Add suffix S to the style number and specify vinyl color number. ▶ See <i>Surface Materials Reference Manual</i> to specify. Add suffix S to the style number and specify leather color number. </td> </tr> </table>	Surface Materials	<ul style="list-style-type: none"> • Fabric price group 1 • Fabric price group 2 • Fabric price group 3 • Fabric price group 4 • Fabric price group 5 • Fabric price group 6 • Fabric price group 7 • Fabric price group 8 • Fabric price group 9 • Fabric price group 10 • Steelcase leather upholstery • Select Surfaces leather price group 1 • Elmosoft leather upholstery • Select Surfaces leather price group 2 • Steelcase vinyl • Customer's Own Material (COM) • Customer's Own Leather (COL) 	<ul style="list-style-type: none"> No cost +\$ 10 +\$ 26 +\$ 35 +\$ 42 +\$ 51 +\$ 62 +\$ 77 +\$ 94 +\$109 +\$313 +\$313 +\$367 +\$367 +\$ 10 No cost +\$135 	<ul style="list-style-type: none"> Specify fabric color number. Specify fabric color number. Specify fabric color number. Specify fabric color number. Specify fabric color number. Specify fabric color number. Specify fabric color number. Specify fabric color number. Specify fabric color number. Specify fabric color number. Specify fabric color number. Add suffix S to the style number and specify leather color number. Add suffix S to the style number and specify Select Surfaces leather price group 1. ▶ See <i>Surface Materials Reference Manual</i>. Add suffix S to the style number and specify Elmosoft leather color number. Add suffix S to the style number and specify Select Surfaces leather price group 2. ▶ See <i>Surface Materials Reference Manual</i>. Add suffix S to the style number and specify vinyl color number. ▶ See <i>Surface Materials Reference Manual</i> to specify. Add suffix S to the style number and specify leather color number. 	<table border="0"> <tr> <td>Fire Code Seating (FCS)</td> <td>+\$ 77</td> <td>Add suffix F to the style number.</td> </tr> <tr> <td>Soil-retardant treatment</td> <td>+\$ 25</td> <td>Specify <i>with soil-retardant treatment</i>.</td> </tr> <tr> <td>Sewn upholstery</td> <td></td> <td></td> </tr> <tr> <td>• Sewn upholstery on chair</td> <td>+\$ 41</td> <td>Add suffix S to the style number.</td> </tr> <tr> <td>Platinum</td> <td></td> <td></td> </tr> <tr> <td>• On frame, base, arm retainer, and outer back</td> <td>+\$ 48</td> <td>Specify <i>with 6249 Platinum</i>.</td> </tr> <tr> <td>Arms</td> <td></td> <td></td> </tr> <tr> <td>• Height-adjustable arms, soft arm caps</td> <td>-\$ 90</td> <td>Specify <i>with height-adjustable arms</i>.</td> </tr> <tr> <td>• Armless</td> <td>-\$282</td> <td>Specify <i>without arms</i>.</td> </tr> <tr> <td>Seat Height</td> <td></td> <td></td> </tr> <tr> <td>• 5" pneumatic seat-height adjustment</td> <td>+\$ 58</td> <td>Specify <i>with 5" pneumatic seat-height adjustment</i>.</td> </tr> <tr> <td>Lumbar</td> <td></td> <td></td> </tr> <tr> <td>• Without lumbar</td> <td>-\$ 57</td> <td>Specify <i>without lumbar</i>.</td> </tr> </table>	Fire Code Seating (FCS)	+\$ 77	Add suffix F to the style number.	Soil-retardant treatment	+\$ 25	Specify <i>with soil-retardant treatment</i> .	Sewn upholstery			• Sewn upholstery on chair	+\$ 41	Add suffix S to the style number.	Platinum			• On frame, base, arm retainer, and outer back	+\$ 48	Specify <i>with 6249 Platinum</i> .	Arms			• Height-adjustable arms, soft arm caps	-\$ 90	Specify <i>with height-adjustable arms</i> .	• Armless	-\$282	Specify <i>without arms</i> .	Seat Height			• 5" pneumatic seat-height adjustment	+\$ 58	Specify <i>with 5" pneumatic seat-height adjustment</i> .	Lumbar			• Without lumbar	-\$ 57	Specify <i>without lumbar</i> .
Surface Materials	<ul style="list-style-type: none"> • Fabric price group 1 • Fabric price group 2 • Fabric price group 3 • Fabric price group 4 • Fabric price group 5 • Fabric price group 6 • Fabric price group 7 • Fabric price group 8 • Fabric price group 9 • Fabric price group 10 • Steelcase leather upholstery • Select Surfaces leather price group 1 • Elmosoft leather upholstery • Select Surfaces leather price group 2 • Steelcase vinyl • Customer's Own Material (COM) • Customer's Own Leather (COL) 	<ul style="list-style-type: none"> No cost +\$ 10 +\$ 26 +\$ 35 +\$ 42 +\$ 51 +\$ 62 +\$ 77 +\$ 94 +\$109 +\$313 +\$313 +\$367 +\$367 +\$ 10 No cost +\$135 	<ul style="list-style-type: none"> Specify fabric color number. Specify fabric color number. Specify fabric color number. Specify fabric color number. Specify fabric color number. Specify fabric color number. Specify fabric color number. Specify fabric color number. Specify fabric color number. Specify fabric color number. Specify fabric color number. Add suffix S to the style number and specify leather color number. Add suffix S to the style number and specify Select Surfaces leather price group 1. ▶ See <i>Surface Materials Reference Manual</i>. Add suffix S to the style number and specify Elmosoft leather color number. Add suffix S to the style number and specify Select Surfaces leather price group 2. ▶ See <i>Surface Materials Reference Manual</i>. Add suffix S to the style number and specify vinyl color number. ▶ See <i>Surface Materials Reference Manual</i> to specify. Add suffix S to the style number and specify leather color number. 																																									
Fire Code Seating (FCS)	+\$ 77	Add suffix F to the style number.																																										
Soil-retardant treatment	+\$ 25	Specify <i>with soil-retardant treatment</i> .																																										
Sewn upholstery																																												
• Sewn upholstery on chair	+\$ 41	Add suffix S to the style number.																																										
Platinum																																												
• On frame, base, arm retainer, and outer back	+\$ 48	Specify <i>with 6249 Platinum</i> .																																										
Arms																																												
• Height-adjustable arms, soft arm caps	-\$ 90	Specify <i>with height-adjustable arms</i> .																																										
• Armless	-\$282	Specify <i>without arms</i> .																																										
Seat Height																																												
• 5" pneumatic seat-height adjustment	+\$ 58	Specify <i>with 5" pneumatic seat-height adjustment</i> .																																										
Lumbar																																												
• Without lumbar	-\$ 57	Specify <i>without lumbar</i> .																																										

▶ Options, continued on next page

Tip: Always add suffixes in alphabetical order when specifying options to Leap seating.

Tip: Leather and vinyl upcharges are in addition to sewn upholstery upcharge.

Tip: Select COMs require sewn application with an additional upcharge. Specify with an **S** suffix.

Tip: Fire Code Seating (FCS) option is available with certain upholstery fabric choices only.

▶ Page 462

▶ Detailed dimensions, page 48

SIN 711.18

► **Options, continued from previous page**

	Options	Price	Required to Specify
Casters	<ul style="list-style-type: none"> Soft, dark grey treaded, dual-wheel roll-control casters for use on hard floors 	+\$25	Specify with soft roll-control casters.
Glides	<ul style="list-style-type: none"> Glides: plastic 	+\$25	Specify with glides.

Specification Information



Style Number	Base Price
46296189	\$2380

Leap 462 Series

Siento 499 Series

Siento desk chairs, designed in collaboration with Jorge Pensi, merge remarkable ergonomic comfort in a slim and sophisticated executive form.

Outer back is fully upholstered.

Patented LiveBack technology (found in Steelcase Leap chair) is embedded in the back to change shape and mimic the user's spine.

Arms are available as either T-arms or enclosed. T-arms are available fixed or adjustable (height, width, pivot and depth).

Arm uprights are available in polished aluminum, platinum, or black.

Five-arm base is available in polished aluminum, platinum, or black.

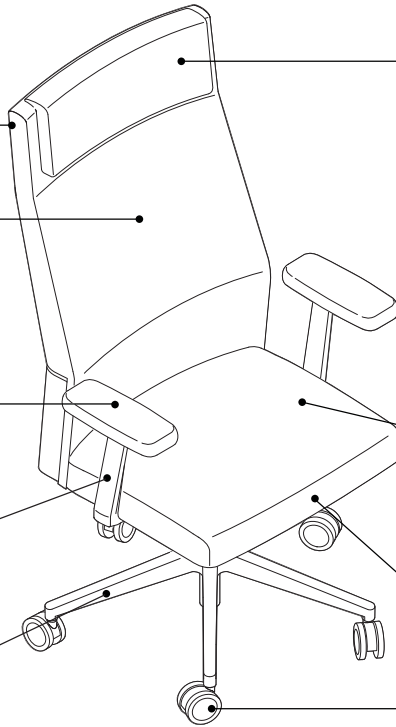

Headrest option provides additional head and neck support.

Seat height adjusts from 16" to 21" and is standard with pneumatic adjustment mechanism. Fixed-height option is also available.

Front seat edge flexes naturally to relieve pressure under the user's thighs.

3" hard dual-wheel casters are standard for use on carpet. Soft dual-wheel casters are available for use on hard floors or chair mats.

Tip: Do not roll the chair across asphalt during installation as this may damage the casters.

Product Details

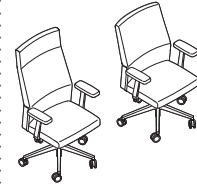

High-back and mid-back desk chairs are available.

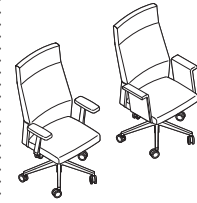

Arms are available as T-arms or enclosed. Fixed T-arms are available in urethane or fully upholstered. Adjustable T-arms are available in urethane only. Enclosed arms are always fully upholstered.

Adjustment Features

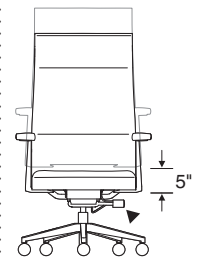

Seat height adjusts pneumatically. To lower, hold handle up while seated. To raise, hold handle up and keep your weight off the chair. Standard range of adjustability is 5" from 16"H to 21"H.

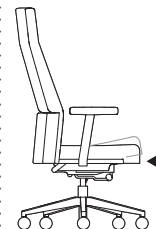

Seat edge flexes, relieving pressure under the user's thighs.

Actual Dimensions

	High-Back Desk Chairs with Headrest	High-Back Desk Chairs without Headrest	Mid-Back Desk Chairs
Overall depth	26"	26"	26"
Overall width—outside of T-arms	27½"	27½"	27½"
Overall width—outside of enclosed arms	29½"	29½"	29½"
Overall height	46¾"—51¾"	46"—51"	40"—45"
Seat depth	17½"	17½"	17½"
Seat width	21"	21"	21"
Back height from seat	31½"	30"	24"
Width between arms	20½"	20½"	20½"
Arm height from seat	8"	8"	8"

Adjustability Features

- Pneumatic seat-height
- Upright back lock
- Back tension control
- Synchro-tilt mechanism

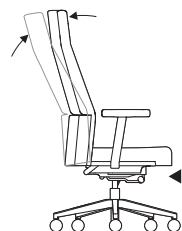
**Upright back lock.**

Flick switch forward to lock; flick switch back to tilt.

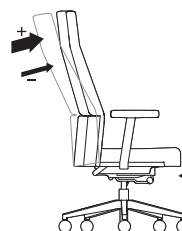
**Back tension control**

adjusts by turning knob. Turn knob forward to increase rate of tension, backward to decrease.

Synchro-tilt mechanism

provides synchronized back movement while feet remain flat on the floor.

Height-, width-, pivot-, and depth-adjustable arms are available on select models of chairs.

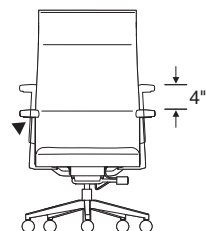
**Arm height adjusts**

independently within a range of 4" (7"–11" from the seat). Push button on outside and under arm cap in while moving arms up or down. Releasing buttons locks arms in position.

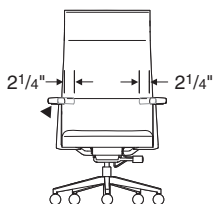

Arm width can be adjusted 2¹/₄" each, 4¹/₂" overall. Grasp arm cap and move in or out.

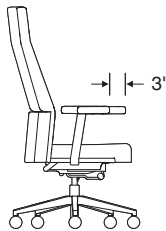

Arm depth adjusts by sliding arm caps back 3". Friction-fit mechanism keeps arms in position.

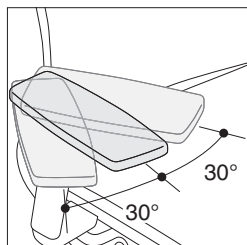

Arms pivot independently, 30° inward and outward.

Surface Materials**Upholstery**

- Fabric
- Fabric with soil-retardant treatment (option)
- Elmosoft leather
- Select Surfaces leather
- COM
- COL

Arms

- Black urethane T-arms
- Upholstered T-arms
- Enclosed upholstered arms

Column

- Black only

Base

- 0835 Black
- 4799 Platinum
- 8046 Polished Aluminum

Casters

- Black wheels with black body on black or platinum base
- Black wheels with polished aluminum body on polished aluminum base

All Steelcase seating with standard upholstery fabrics

complies with requirements of the State of California Technical Bulletin 117-2013. All standard seating is labeled to be in compliance with California 117-2013.

Programs & Services

► See the *Surface Materials Reference Manual* for further detail about programs and services offered for seating.

The Customer's Own Material (COM & COL) Program

offers the opportunity for customers to select fabrics that are not offered through the standard Steelcase surface materials program for use on Steelcase products. Through the COM and COL program, Steelcase will test your materials for application on Steelcase products. Once approved, you can place your order. Steelcase will facilitate the entire ordering process and give you a production schedule. Steelcase will order the COM and COL fabric directly from the textile manufacturer. For up-to-date information regarding fabric test results for all COM and COL fabrics and details regarding yardage requirements for most seating lines, visit the COM website. To locate the COM website:

- Visit www.steelcase.com

Soil retardants are treatments that provide long-term soil and stain resistance to a fabric without affecting the shade or the integrity of the fabric. The following Steelcase Textiles are available pre-treated with soil retardant. (You do not need to select the soil-retardant option for these fabrics and incur the upcharge.)

- Jacks
- Link
- Spyder

For information on soil retardant fabrics on Select Surfaces, please refer to the *Surface Materials Reference Manual*.

Soil-retardant treatment is available on all other seating fabrics at an additional upcharge per seating unit. To order this option, please select "Soil-Retardant Treatment" under "Optional Accessories."

For soil-retardant treatment on COMs, please select "Soil-Retardant Treatment" under "Optional Accessories". Minimums or additional yardage may be required. Please contact the vendor directly for specific information.

Extended lead times may be necessary for this service.

Contact your Steelcase Solutions Fulfillment Team Representative at (1.888.783.3522) or send an email to lineone@steelcase.com.

Resources**Printed Materials**

- Siento Brochure (06-0001282)

Online Resources

- Siento User Guide available on www.steelcase.com
- Environmental profiles available on www.steelcase.com/sustainability

Siento Design Package High-Back Executive Chair

SIN 711.18



Tip: This design package allows you to obtain the preselected features at a lower price than if specifying as a standard model number.

Tip: Options or substitutions are not available on this design package.

Standard Includes		Required to Specify
<ul style="list-style-type: none"> ▶ Need help? Product details, page 68 	<ul style="list-style-type: none"> • Back tension control • 5" pneumatic seat-height adjustment • Upright back lock • Fully upholstered outer back • Front seat edge flex • LiveBack technology • T-arms: upholstered • Headrest • Upholstery: Elmosoft leather • Five-arm base and arm uprights: 8046 Polished Aluminum • Column: black only • 3"-diameter, hard composition, dual-wheel casters: black wheels with polished aluminum body 	<ul style="list-style-type: none"> 1 Style number 2 Elmosoft leather color number ▶ See <i>Surface Materials</i>, page 432.

Specification Information	
• Style Number	• Price
499SIENTO	\$2355
:	:
:	:

Siento Executive Desk Chairs

SIN 711.18



Tip: When a black or platinum painted base is specified, the casters will be black. When a polished aluminum base is specified, the casters will have black wheels with polished aluminum body.

Standard Includes		Required to Specify
<ul style="list-style-type: none"> ▶ Need help? Product details, page 68 	<ul style="list-style-type: none"> • Back tension control • 5" pneumatic seat-height adjustment • Upright back lock • Front seat edge flex • LiveBack technology • Fully upholstered outer back • Adjustable T-arms, if selected: soft black urethane • Fixed T-arms, if selected: soft black urethane • Enclosed arms, if selected: fully upholstered • Upholstery: fabric price group 1 • Five-arm base: paint or Polished Aluminum • Column: black only • 3"-diameter, hard-composition, dual-wheel casters: black 	<ol style="list-style-type: none"> 1 Style number 2 Paint color number for base and arm supports 3 Fabric color number for upholstery 4 Options, if selected (see below) <p>▶ See <i>Surface Materials</i>, page 432.</p>

Options	Price	Required to Specify
Surface Materials		
Upholstery on seat and back		
• Fabric price group 1	No cost	Specify fabric color number.
• Fabric price group 2	+\$ 26	Specify fabric color number.
• Fabric price group 3	+\$ 48	Specify fabric color number.
• Fabric price group 4	+\$ 68	Specify fabric color number.
• Fabric price group 5	+\$ 85	Specify fabric color number.
• Fabric price group 6	+\$106	Specify fabric color number.
• Fabric price group 7	+\$121	Specify fabric color number.
• Fabric price group 8	+\$153	Specify fabric color number.
• Fabric price group 9	+\$188	Specify fabric color number.
• Fabric price group 10	+\$213	Specify fabric color number.
• Customer's Own Material (COM)	+\$ 37	▶ See <i>Surface Materials Reference Manual</i> . Add suffix S to the style number and specify leather color number.
• Customer's Own Leather (COL)	+\$ 37	Add suffix S to the style number and specify leather color number.
• Steelcase leather upholstery	+\$591	Add suffix S to the style number and specify Select Surfaces leather price group 1.
• Select Surfaces leather price group 1	+\$591	▶ See <i>Surface Materials Reference Manual</i> . Add suffix S to the style number and specify Elmosoft leather color number.
• Elmosoft leather	+\$828	▶ See <i>Surface Materials</i> , page 432. Add suffix S to the style number and specify Select Surfaces leather price group 2.
• Select Surfaces leather price group 2	+\$828	▶ See <i>Surface Materials Reference Manual</i> . Add suffix S to the style number.
• Sewn upholstery	No cost	
Contrasting upholstery on seat and back		
• Contrasting fabrics	+\$ 31	Add suffix K to the style number and specify fabric color numbers.
Contrasting upholstery on seat		
• Fabric price group 1	No cost	Specify fabric color number.
• Fabric price group 2	+\$ 13	Specify fabric color number.
• Fabric price group 3	+\$ 24	Specify fabric color number.
• Fabric price group 4	+\$ 34	Specify fabric color number.
• Fabric price group 5	+\$ 42	Specify fabric color number.
• Fabric price group 6	+\$ 53	Specify fabric color number.
• Fabric price group 7	+\$ 60	Specify fabric color number.
• Fabric price group 8	+\$ 76	Specify fabric color number.
• Fabric price group 9	+\$ 94	Specify fabric color number.
• Fabric price group 10	+\$106	Specify fabric color number.

▶ Options, continued on next page

▶ Detailed dimensions, page 68

► Options, continued from previous page

Options	Price	Required to Specify	
Surface Materials, continued			
Contrasting upholstery on seat, continued			
• Steelcase leather upholstery	+\$295	Add suffix S to the style number and specify leather color number.	
• Select Surfaces leather price group 1	+\$295	Add suffix S to the style number and specify leather color number.	
• Elmosoft leather upholstery	+\$414	Add suffix S to the style number and specify leather color number.	
• Select Surfaces leather price group 2	+\$414	Add suffix S to the style number and specify leather color number.	
• Sewn upholstery	No cost	Add suffix S to the style number.	
• Customer's Own Material (COM)	+\$ 18	► See <i>Surface Materials Reference Manual</i> to specify.	
• Customer's Own Leather (COL)	+\$ 18	Add suffix S to the style number and specify leather color number.	
Contrasting upholstery on back			
• Fabric price group 1	No cost	Specify fabric color number.	
• Fabric price group 2	+\$ 13	Specify fabric color number.	
• Fabric price group 3	+\$ 24	Specify fabric color number.	
• Fabric price group 4	+\$ 34	Specify fabric color number.	
• Fabric price group 5	+\$ 43	Specify fabric color number.	
• Fabric price group 6	+\$ 53	Specify fabric color number.	
• Fabric price group 7	+\$ 61	Specify fabric color number.	
• Fabric price group 8	+\$ 77	Specify fabric color number.	
• Fabric price group 9	+\$ 94	Specify fabric color number.	
• Fabric price group 10	+\$107	Specify fabric color number.	
• Steelcase leather upholstery	+\$296	Add suffix S to the style number and specify leather color number.	
• Select Surfaces leather price group 1	+\$296	Add suffix S to the style number and specify leather color number.	
• Elmosoft leather upholstery	+\$414	Add suffix S to the style number and specify leather color number.	
• Select Surfaces leather price group 2	+\$414	Add suffix S to the style number and specify leather color number.	
• Sewn upholstery	No cost	Add suffix S to the style number.	
• Customer's Own Material (COM)	+\$ 19	See <i>Surface Materials Reference Manual</i> to specify.	
• Customer's Own Leather (COL)	+\$ 19	Add suffix S to the style number and specify leather color number.	
Soil-retardant treatment			
	+\$ 25	Specify <i>with soil-retardant treatment</i> .	
T-arms			
• Fully upholstered T-arms	+\$ 91	Specify <i>with fully upholstered T-arms</i> .	
Base and casters			
• 0835 Black base and black casters	No cost	Specify <i>with 0835 Black base</i> .	
• 4799 Platinum base and black casters	+\$ 86	Specify <i>with 4799 Platinum base</i> .	
Seat Height	• 18" fixed seat height	No cost	Specify <i>with fixed seat height</i> .
Headrest	• Headrest on high-back chairs only	+\$118	Specify <i>with headrest</i> .
Casters	• Soft, dark grey treaded, dual-wheel roll-control casters for use on hard floors	+\$ 25	Specify <i>with soft roll-control casters</i> .

Tip: Fully upholstered option is available on fixed T-arm style numbers only.

Tip: When the standard polished aluminum base is specified along with adjustable T-arms, you must specify the finish for arm uprights in either 6205 Black or 6249 Platinum.

Tip: When the base and adjustable T-arms are specified in 4799 Platinum, the arm upright will be in 4799 Platinum and the lower section of the arm will be in 6205 Black.



► Specification Information, on next page

Siento Executive Desk Chairs, continued

SIN 711.18



► Options, on previous page

Specification Information

	Fixed T-Arms		Enclosed Upholstered Arms		Adjustable T-Arms	
						
Description	Style Number	Base Price	Style Number	Base Price	Style Number	Base Price

High-Back Chairs

Painted Base	499211	\$1843	499212	\$2085	499213	\$2128
Polished Aluminum Base	499221	\$2207	499222	\$2449	499223	\$2492

	Fixed T-Arms		Enclosed Upholstered Arms		Adjustable T-Arms	
						
Description	Style Number	Base Price	Style Number	Base Price	Style Number	Base Price

Mid-Back Chairs

Painted Base	499111	\$1722	499112	\$1964	499113	\$2007
Polished Aluminum Base	499121	\$2086	499122	\$2328	499123	\$2371

Criterion 453 Series

Criterion is a high-performance chair, ideal for users who sit for long periods of time. As the world's best-selling chair with the broadest range of adjustments, Criterion meets the long-term comfort needs of today's diverse workforce.

Outer back and outer seat is plastic. Fully upholstered outer back is an option.

Arm height adjusts independently within a 4" range to help relieve upper back and shoulder fatigue.

Seat depth adjusts within a 3" range and is available as an option.

Seat height adjusts within a 5" range with a pneumatic adjustment mechanism. Meets ANSI/HFES standards.

Five-arm base is standard.

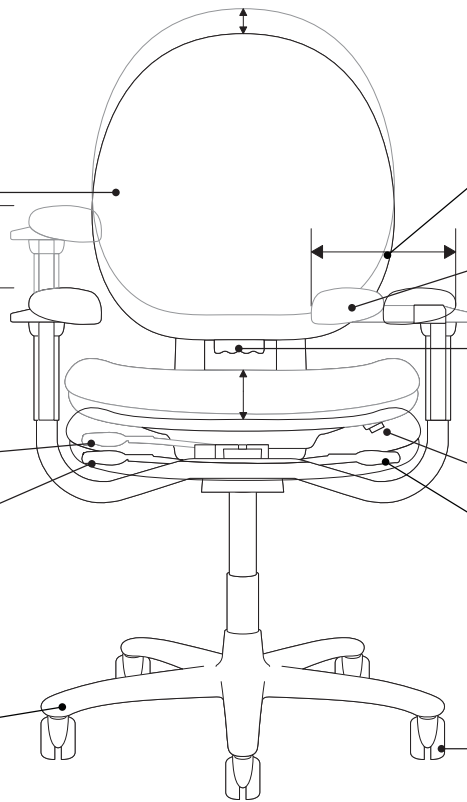

Arm width adjusts within a 4" range for each arm to provide forearm support in neutral position for 5th to 95th percentile office workers.

Arm caps can pivot independently 14° in and 21° out to accommodate individual user preferences.

Back height adjusts up and down within a 2" range to help ensure healthful back posture.

Variable back stop is standard.

Seat angle adjusts forward, upright, and reclined to suit user.

Castors have hard, dual-wheels that roll smoothly on carpets. They are 2 1/5" diameter for increased mobility. Soft, dual-wheel casters are available for use on hard floors or chair mats.
Tip: Do not roll the chair across asphalt during installation as this may damage the casters.

Product Details



Three basic sizes are available—high-back, mid-back, and Plus. All are offered with and without arms. High-back and mid-back are also available as stools.

Criterion features a seat angle adjustment which allows the seat angle to function in a fixed or articulating mode. Variable back stop will lock the back in an upright position or allow the user to set a specific back stop position which the chair will recline to.

Criterion Plus has an upright back lock and offers a wider seat with more space between the arms to accommodate workers who need a larger chair. The Criterion Plus chair is tested to hold up to 400 lbs. under normal use.

Upholstery Details



Criterion is standard with a molded upholstered seat and back.



Sewn upholstery can be specified to accommodate vinyl and other high-performance fabrics. Seat and back cushions feature a stitched detail. Specify using an **S** suffix.



Non-sewn seat upholstery can be specified to accommodate vinyl and other high-performance fabrics without a seam on the seat. Back cushion will have stitched detail. Specify using an **X** suffix. This option is available on models with adjustable seat depth only.

Adjustment Features

Seat Adjustments

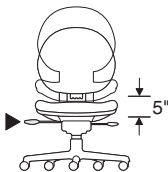

Seat height adjusts pneumatically. To lower, hold handle up while seated. To raise, hold handle up and keep your weight off the chair. Range of adjustability is 6" from 16"H to 21"H.

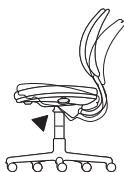

Seat angle adjusts by pulling handle up and shifting your weight to alter seat angle. Release handle to lock. This feature is standard.

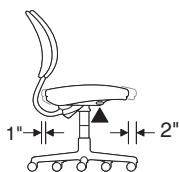

Seat depth adjusts by pulling handle up. Slide seat forward or back to accommodate various leg lengths. Release handle to lock. This feature is optional. For Criterion Plus, seat depth is a maintenance adjustment. The chair has three depth settings: 15", 16⁵/₈", and 18¹/₄". The chair will ship in the 18¹/₄" position.

Back Adjustments

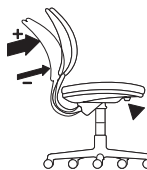

Back tension adjusts by turning knob. Turn knob clockwise to increase tension, counterclockwise to decrease. This feature is standard.



Variable back stop. Hold switch forward to recline. Lean back to desired back angle. Release switch to set tilt range. *Tip: To lock in upright position, remove weight from back and release switch.*

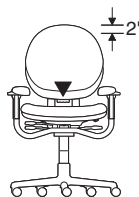

Back height adjusts within a 2" range by pulling handle forward while moving chair back up or down. Release handle to lock chair back in position. This feature is standard.

Arm Adjustments

Arms are available fixed, height- and width-adjustable, and height-, width-, and pivot-adjustable.

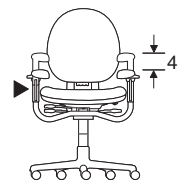

Arm height adjusts independently within a range of 4". Squeeze triggers in while moving arms up or down. Releasing triggers locks arms in position.

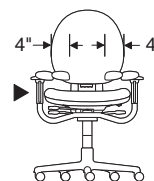

Arm width adjusts independently on chairs with this option. Grasp arm and move in or out. Arm will stay where positioned.

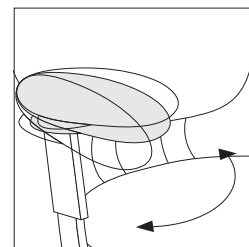

Arms pivot independently on models with height-, width-, and pivot-adjustable arms, 35° inward and outward. Grasp arm and push front to left or right.

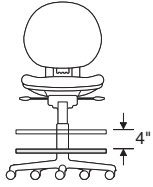
Other Features

Foot ring height on stools adjusts by first lifting ring and rotating it counter-clockwise to unlock. Then raise or lower ring up to 4" to desired position before rotating it clockwise to lock.

Alternative casters and glides are available for specific applications, including soft-wheel casters for hard floors.

Glides are 2"H and interchangeable with casters.

Surface Materials

► See surface materials on page 432 for specific availability or refer to the *Surface Materials Reference Manual* for further information.

Upholstery

- Fabric
- Fabric with soil-retardant treatment (option)
- Leather
- Elmosoft leather
- Select Surfaces leather
- Vinyl

Hard components

(base, arms, plastic arm caps, outer back, outer seat, and foot ring)

- Monochromatic color from list of seating plastic color numbers will apply to all hard components.

Outer back and outer seat

- Plastic color to match color of other "hard components"
- Fully upholstered outer back with plastic color outer seat

Arms

- Soft vinyl arm caps to match the plastic color of the other "hard components"

Casters

- Plastic color to match other "hard components"

Foot ring on stools

- Plastic color to match other "hard components"
- 9201 Polished Chrome

Glides

- Stainless steel only

All Steelcase seating with standard upholstery fabrics

complies with requirements of the State of California Technical Bulletin 117-2013. All standard seating is labeled to be in compliance with California 117-2013.

Programs & Services

► See the *Surface Materials Reference Manual* for further detail about programs and services offered for seating.

The Customer's Own Material (COM) Program

offers the opportunity for customers to select fabrics that are not offered through the standard Steelcase surface materials program for use on Steelcase products. Through the COM program, Steelcase will test your materials for application on Steelcase products. Once approved, you can place your order. Steelcase will facilitate the entire ordering process and give you a production schedule. Steelcase will order the COM fabric directly from the textile manufacturer. For up-to-date information regarding fabric test results for all COM fabrics and details regarding yardage requirements for most Seating lines, visit the COM website. To locate the COM website:

- Visit www.steelcase.com

Soil retardants are treatments that provide long-term soil and stain resistance to a fabric without affecting the shade or the integrity of the fabric. The following Steelcase Textiles are available pre-treated with soil retardant. (You do not need to select the soil-retardant option for these fabrics and incur the upcharge.)

- Jacks
- Link
- Spyder

For information on soil retardant fabrics on Select Surfaces, please refer to the *Surface Materials Reference Manual*.

Soil-retardant treatment is available on all other seating fabrics at an additional upcharge. To order this option, please select "Soil-Retardant Treatment" under "Optional Accessories."

For soil-retardant treatment on COMs, please select "Soil-Retardant Treatment" under "Optional Accessories." Minimums or additional yardage may be required. Please contact the vendor directly for specific information.

Extended lead times may be necessary for this service.

Contact your Steelcase Solutions Fulfillment Team Representative or contact Line 1 at 1.888.STEELCASE (1.888.783.3522) or send an email to lineone@steelcase.com.

Dimensions

► Page 80

Resources**Printed Materials**

► Criterion Brochure (10-000305)

Online Resources

- Adjustability Video available on www.steelcase.com
- Criterion user Guide available on www.steelcase.com
- Environmental profiles available on www.steelcase.com/sustainability

Criterion Upholstery

What Is It?

Fabric, leather, or vinyl-covered back and seat.

Fabric

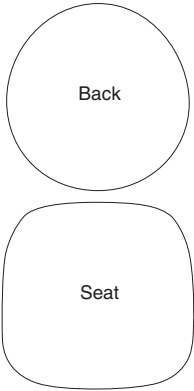

Criterion is standard with a molded upholstered seat and back.

Non-Sewn Seat

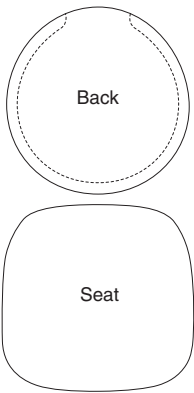

Non-sewn seat upholstery can be specified to accommodate vinyl and other high-performance fabrics without a seam on the seat. Back cushion will have stitched detail.

- Specify using an **X** suffix.
- Available only on models with adjustable seat depth.

Leather, Vinyl, and Select Fabrics

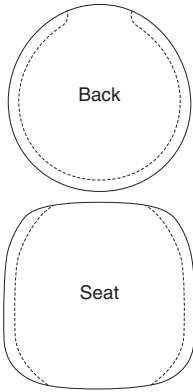

Sewn upholstery can be specified to accommodate vinyl and other high-performance fabrics. Seat and back cushions feature a stitched detail.

- Specify using an **S** suffix.
- Plus models come standard with sewn upholstery.

Pattern alignment at the lumbar seam cannot be guaranteed.

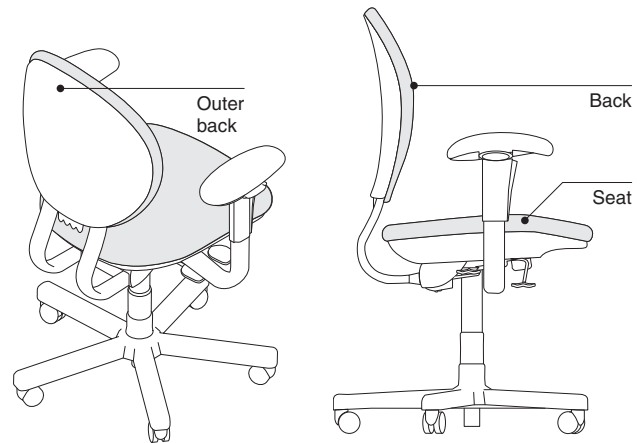
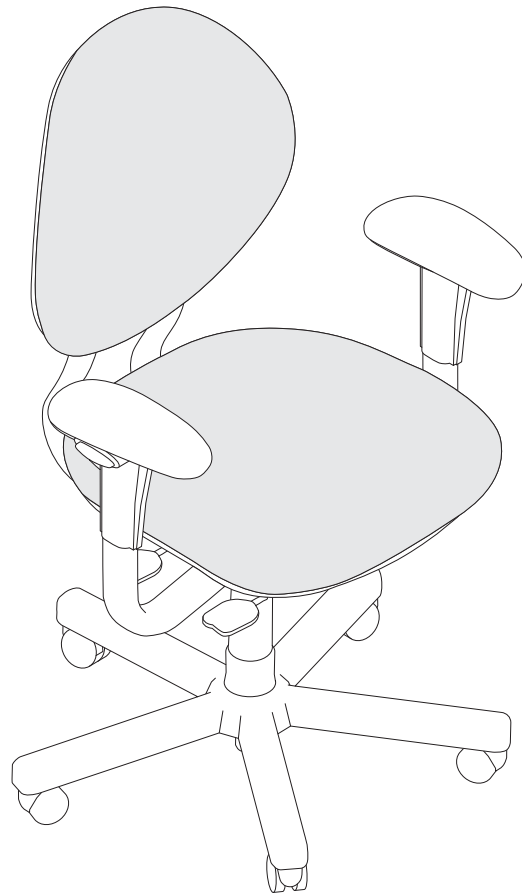

Plastic outer back is fully exposed. Fully upholstered outer back with plastic colored outer seat is available. Plus models are only available with a fully upholstered outer back.

Seat and back cushions can be removed and replaced if damaged.

Dimensions

Criterion 453 Series

Features	Overall Depth	Width	Height	Seat Depth	Functional Seat Depth	Seat Width	Seat Height from Floor	Ring Height from Floor	Back Width
----------	---------------	-------	--------	------------	-----------------------	------------	------------------------	------------------------	------------

Criterion 453 Series

High-Back Work Chairs

22 1/2"-25 1/2"	27 1/2"	37 1/2"-44 1/2"	19 1/2"	16 1/4"*	19 1/2"	16"-21"	N.A.	18"
-----------------	---------	-----------------	---------	----------	---------	---------	------	-----

Mid-Back Work Chairs

22 1/2"-25 1/2"	27 1/2"	34"-41"	19 1/2"	16 1/4"*	19 1/2"	16"-21"	N.A.	18"
-----------------	---------	---------	---------	----------	---------	---------	------	-----

High-Back Stools

22 1/2"-25 1/2"	27 1/2"	46"-53"	19 1/2"	16 1/4"*	19 1/2"	25"-30"	8 3/4"-12 3/4"	18"
-----------------	---------	---------	---------	----------	---------	---------	----------------	-----

Mid-Back Stools

22 1/2"-25 1/2"	27 1/2"	43"-50"	19 1/2"	16 1/4"*	19 1/2"	25"-30"	8 3/4"-12 3/4"	18"
-----------------	---------	---------	---------	----------	---------	---------	----------------	-----

Plus High-Back Work Chairs

22 1/2"-25 1/2"	31 1/2"	38"-45"	19 3/4"	18 1/4"**	19 3/4"	17"-22"	N.A.	22"
-----------------	---------	---------	---------	-----------	---------	---------	------	-----

* Models with adjustable seat depth 15 1/4"-18 1/4".

** Plus models with adjustable seat depth require a maintenance adjustment.

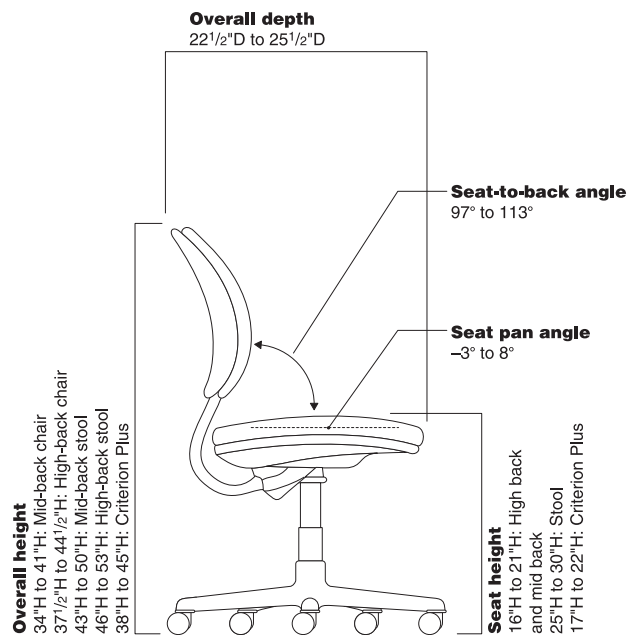
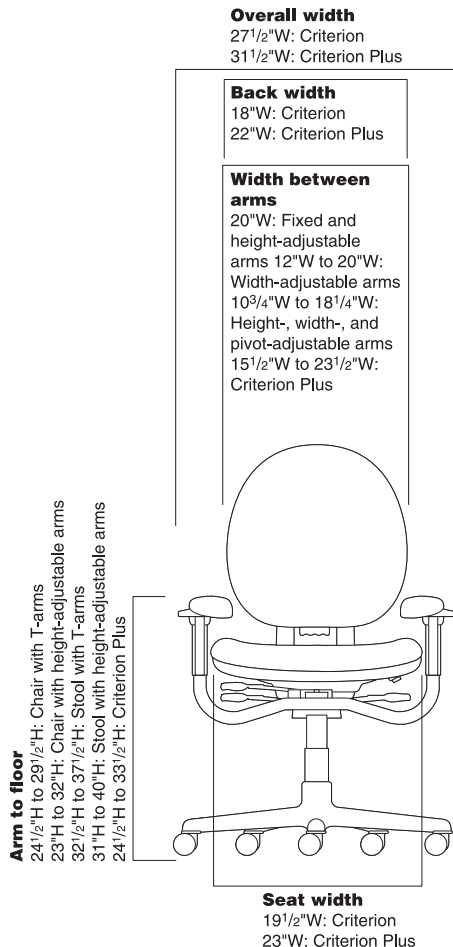

• Back Height from Seat	• Back Lumbar Height	• Width Between Fixed-Height Arms	• Width Between Height- and Width-Adjustable Arms	• Width Between Height-, Width-, and Pivot-Adjustable Arms	• Arm to Floor	• Arm Height from Seat	• Arm Cap Pivot Range	• Seat Pan Angle	• Angle Between Seat and Back
High-Back Work Chairs									
22"-24"	8"	20"	12"-20"	10 ³ / ₄ "-18 ¹ / ₄ "	23"-32"	7"-11"	35°	-3°-8°	97°-113°
Mid-Back Work Chairs									
19 ¹ / ₂ "-21 ¹ / ₂ "	8"	20"	12"-20"	10 ³ / ₄ "-18 ¹ / ₄ "	23"-32"	7"-11"	35°	-3°-8°	97°-113°
High-Back Stools									
22"-24"	8"	20"	12"-20"	10 ³ / ₄ "-18 ¹ / ₄ "	31"-40"	7"-11"	35°	-3°-8°	97°-113°
Mid-Back Stools									
19 ¹ / ₂ "-21 ¹ / ₂ "	8"	20"	12"-20"	10 ³ / ₄ "-18 ¹ / ₄ "	31"-40"	7"-11"	35°	-3°-8°	97°-113°
Plus High-Back Work Chairs									
23"-25"	9"	23 ¹ / ₂ "	15 ¹ / ₂ "-23 ¹ / ₂ "	N.A.	24 ¹ / ₂ "-33 ¹ / ₂ "	7 ¹ / ₂ "-11 ¹ / ₂ "	N.A.	1°-10°	97°-113°

Criterion 453 Series High-Back Work Chairs

SIN 711.18



Standard Includes	Required to Specify
<ul style="list-style-type: none"> ▶ Need help? Product details, page 76 • Back height adjustment • Seat angle adjustment • Variable back stop • Back tension adjustment • Arms, if selected: plastic color to match base • Outer back and outer seat: plastic • Upholstery: fabric price group 1 • Five-arm base: plastic • 2½"-diameter, hard composition, dual-wheel casters: black plastic 	<ol style="list-style-type: none"> 1 Style number 2 Plastic color number for base, outer back, outer seat, and arms 3 Fabric color number for upholstery 4 Options, if selected (see below) <p>▶ See <i>Surface Materials</i>, page 432.</p>

Tip: Leather and vinyl upcharges are in addition to sewn upholstery upcharge.

Options	Price	Required to Specify
Surface Materials		
Upholstery on seat and back		
• Fabric price group 1	No cost	Specify fabric color number.
• Fabric price group 2	+\$ 26	Specify fabric color number.
• Fabric price group 3	+\$ 48	Specify fabric color number.
• Fabric price group 4	+\$ 68	Specify fabric color number.
• Fabric price group 5	+\$ 85	Specify fabric color number.
• Fabric price group 6	+\$106	Specify fabric color number.
• Fabric price group 7	+\$121	Specify fabric color number.
• Fabric price group 8	+\$153	Specify fabric color number.
• Fabric price group 9	+\$188	Specify fabric color number.
• Fabric price group 10	+\$213	Specify fabric color number.
• Steelcase leather upholstery	+\$623	Add suffix S to the style number and specify leather color number.
• Select Surfaces leather price group 1	+\$623	Add suffix S to the style number and specify Select Surfaces leather price group 1.
• Elmosoft leather upholstery	+\$728	▶ See <i>Surface Materials Reference Manual</i> . Add suffix S to the style number and specify Elmosoft leather color number.
• Select Surfaces leather price group 2	+\$728	Add suffix S to the style number and specify Select Surfaces leather price group 2.
• Steelcase vinyl	+\$ 26	▶ See <i>Surface Materials Reference Manual</i> . Add suffix S to the style number and specify vinyl color number.
• Customer's Own Material (COM)	No cost	▶ See <i>Surface Materials Reference Manual</i> to specify.
• Customer's Own Leather (COL)	+\$376	Add suffix S to the style number and specify leather color number.
Fully upholstered		
• Outer back	+\$110	Add suffix B to the style number.
Sewn upholstery		
• Sewn upholstery applied	+\$ 51	Add suffix S to the style number.
Non-sewn seat upholstery		
• Non-sewn seat upholstery applied	+\$ 94	Add suffix X to the style number.
Contrasting upholstery on seat and back		
• Contrasting fabrics	+\$ 31	Add suffix K to the style number and specify fabric color numbers.

▶ **Options, continued on next page**

*Tip: Suffixes other than **K** for contrasting fabric, will be added in alphabetical order when specifying options. The contrasting fabric suffix, **K**, will always be at the end of the style number.*

▶ Detailed dimensions, page 80

► Options, continued from previous page

Options	Price	Required to Specify
Surface Materials, continued		
Contrasting upholstery on seat		
• Fabric price group 1	No cost	Specify fabric color number.
• Fabric price group 2	+\$ 13	Specify fabric color number.
• Fabric price group 3	+\$ 24	Specify fabric color number.
• Fabric price group 4	+\$ 34	Specify fabric color number.
• Fabric price group 5	+\$ 42	Specify fabric color number.
• Fabric price group 6	+\$ 53	Specify fabric color number.
• Fabric price group 7	+\$ 61	Specify fabric color number.
• Fabric price group 8	+\$ 76	Specify fabric color number.
• Fabric price group 9	+\$ 94	Specify fabric color number.
• Fabric price group 10	+\$106	Specify fabric color number.
• Steelcase leather upholstery	+\$311	Add suffix S to the style number and specify leather color number.
• Select Surfaces leather price group 1	+\$311	Add suffix S to the style number and specify leather color number.
• Elmosoft leather upholstery	+\$364	Add suffix S to the style number and specify leather color number.
• Select Surfaces leather price group 2	+\$364	Add suffix S to the style number and specify leather color number.
• Steelcase vinyl	+\$ 13	Add suffix S to the style number and specify vinyl color number.
• Customer's Own Material (COM)	No cost	► See <i>Surface Materials Reference Manual</i> .
• Customer's Own Leather (COL)	+\$188	Add suffix S to the style number and specify leather color number.
Contrasting upholstery on back		
• Fabric price group 1	No cost	Specify fabric color number.
• Fabric price group 2	+\$ 13	Specify fabric color number.
• Fabric price group 3	+\$ 24	Specify fabric color number.
• Fabric price group 4	+\$ 34	Specify fabric color number.
• Fabric price group 5	+\$ 43	Specify fabric color number.
• Fabric price group 6	+\$ 53	Specify fabric color number.
• Fabric price group 7	+\$ 61	Specify fabric color number.
• Fabric price group 8	+\$ 77	Specify fabric color number.
• Fabric price group 9	+\$ 94	Specify fabric color number.
• Fabric price group 10	+\$107	Specify fabric color number.
• Steelcase leather upholstery	+\$312	Add suffix S to the style number and specify leather color number.
• Select Surfaces leather price group 1	+\$312	Add suffix S to the style number and specify leather color number.
• Elmosoft leather upholstery	+\$364	Add suffix S to the style number and specify leather color number.
• Select Surfaces leather price group 2	+\$364	Add suffix S to the style number and specify leather color number.
• Steelcase vinyl	+\$ 13	Add suffix S to the style number and specify vinyl color number.
• Customer's Own Material (COM)	No cost	► See <i>Surface Materials Reference Manual</i> .
• Customer's Own Leather (COL)	+\$188	Add suffix S to the style number and specify leather color number.
Soil-retardant treatment	+\$ 25	Specify with <i>soil-retardant treatment</i> .
Casters		
• Soft, dual-wheel casters or use on hard floors	+\$ 25	Specify with <i>soft casters</i> .
Glides		
• Stainless steel glides	+\$ 25	Specify with <i>GLD453</i> .

► Specification Information, on next page

Tip: Leather and vinyl upcharges are in addition to sewn upholstery upcharge.

Seating

Criterion 453 Series High-Back Work Chairs, continued

SIN 711.18

► **Options, on previous page**

Specification Information

Height-, Width-, and Pivot-Adjustable Arms



• **Style Number**
 • **Base Price**

Height- and Width-Adjustable Arms



• **Style Number**
 • **Base Price**

Fixed-Height Arms



• **Style Number**
 • **Base Price**

Soft Arm Caps

Pneumatic

4535331P	\$1406	4535331W	\$1500	4535331	\$1244
-----------------	--------	-----------------	--------	----------------	--------

Pneumatic with Adjustable Seat Depth

4535331DP	\$1519	4535331DW	\$1613	4535331D	\$1357
------------------	--------	------------------	--------	-----------------	--------

Without Arms



• **Style Number**
 • **Base Price**

Pneumatic

4535301	\$1066
----------------	--------

Pneumatic with Adjustable Seat Depth

4535301D	\$1179
-----------------	--------

Criterion 453 Series Mid-Back Work Chairs

SIN 711.18



Standard Includes	Required to Specify
<p>► Need help? Product details, page 76</p> <ul style="list-style-type: none"> • Back height adjustment • Seat angle adjustment • Variable back stop • Back tension adjustment • Arms, if selected: plastic color to match base • Outer back and outer seat: plastic • Upholstery: fabric price group 1 • Five-arm base: plastic • 2½"-diameter, hard composition, dual-wheel casters: black plastic 	<ol style="list-style-type: none"> 1 Style number 2 Plastic color number for base, outer back, outer seat, and arms 3 Fabric color number for upholstery 4 Options, if selected (see below) <p>► See <i>Surface Materials</i>, page 432.</p>

Options	Price	Required to Specify
<p>Surface Materials</p> <p>Upholstery on seat and back</p> <ul style="list-style-type: none"> • Fabric price group 1 No cost • Fabric price group 2 +\$ 26 • Fabric price group 3 +\$ 48 • Fabric price group 4 +\$ 68 • Fabric price group 5 +\$ 85 • Fabric price group 6 +\$106 • Fabric price group 7 +\$121 • Fabric price group 8 +\$153 • Fabric price group 9 +\$188 • Fabric price group 10 +\$213 • Steelcase leather upholstery +\$623 • Select Surfaces leather price group 1 +\$623 • Elmosoft leather upholstery +\$728 • Select Surfaces leather price group 2 +\$728 • Steelcase vinyl +\$ 26 • Customer's Own Material (COM) No cost • Customer's Own Leather (COL) +\$376 <p>Fully upholstered</p> <ul style="list-style-type: none"> • Outer back +\$110 <p>Sewn upholstery</p> <ul style="list-style-type: none"> • Sewn upholstery applied +\$ 51 <p>Non-sewn seat upholstery</p> <ul style="list-style-type: none"> • Non-sewn seat upholstery applied +\$ 94 <p>Contrasting upholstery on seat and back</p> <ul style="list-style-type: none"> • Contrasting fabrics +\$ 31 		<p>Specify fabric color number.</p> <p>Specify fabric color number.</p> <p>Specify fabric color number.</p> <p>Specify fabric color number.</p> <p>Specify fabric color number.</p> <p>Specify fabric color number.</p> <p>Specify fabric color number.</p> <p>Specify fabric color number.</p> <p>Specify fabric color number.</p> <p>Specify fabric color number.</p> <p>Specify fabric color number.</p> <p>Add suffix S to the style number and specify leather color number.</p> <p>Add suffix S to the style number and specify Select Surfaces leather price group 1.</p> <p>► See <i>Surface Materials Reference Manual</i>. Add suffix S to the style number and specify Elmosoft leather color number.</p> <p>Add suffix S to the style number and specify Select Surfaces leather price group 2.</p> <p>► See <i>Surface Materials Reference Manual</i>. Add suffix S to the style number and specify vinyl color number.</p> <p>► See <i>Surface Materials Reference Manual</i> to specify.</p> <p>Add suffix S to the style number and specify leather color number.</p> <p>Add suffix B to the style number.</p> <p>Add suffix S to the style number.</p> <p>Add suffix X to the style number.</p> <p>Add suffix K to the style number and specify fabric color numbers.</p>

► Options, continued on next page

Tip: Leather and vinyl upcharges are in addition to sewn upholstery upcharge.

Tip: Suffixes other than **K** for contrasting fabric, will be added in alphabetical order when specifying options. The contrasting fabric suffix, **K**, will always be at the end of the style number.

► Detailed dimensions, page 80

► Options, continued from previous page

	Options	Price	Required to Specify	
Surface Materials, continued	Contrasting upholstery on seat			
	• Fabric price group 1	No cost	Specify fabric color number.	
	• Fabric price group 2	+\$ 13	Specify fabric color number.	
	• Fabric price group 3	+\$ 24	Specify fabric color number.	
	• Fabric price group 4	+\$ 34	Specify fabric color number.	
	• Fabric price group 5	+\$ 42	Specify fabric color number.	
	• Fabric price group 6	+\$ 53	Specify fabric color number.	
	• Fabric price group 7	+\$ 61	Specify fabric color number.	
	• Fabric price group 8	+\$ 76	Specify fabric color number.	
	• Fabric price group 9	+\$ 94	Specify fabric color number.	
	• Fabric price group 10	+\$106	Specify fabric color number.	
	• Steelcase leather upholstery	+\$311	Add suffix S to the style number and specify leather color number.	
	• Select Surfaces leather price group 1	+\$311	Add suffix S to the style number and specify leather color number.	
	• Elmosoft leather upholstery	+\$364	Add suffix S to the style number and specify leather color number.	
	• Select Surfaces leather price group 2	+\$364	Add suffix S to the style number and specify leather color number.	
	• Steelcase vinyl	+\$ 13	Add suffix S to the style number and specify vinyl color number.	
	• Customer's Own Material (COM)	No cost	► See <i>Surface Materials Reference Manual</i> .	
	• Customer's Own Leather (COL)	+\$188	Add suffix S to the style number and specify leather color number.	
		Contrasting upholstery on back		
		• Fabric price group 1	No cost	Specify fabric color number.
	• Fabric price group 2	+\$ 13	Specify fabric color number.	
	• Fabric price group 3	+\$ 24	Specify fabric color number.	
	• Fabric price group 4	+\$ 34	Specify fabric color number.	
	• Fabric price group 5	+\$ 43	Specify fabric color number.	
	• Fabric price group 6	+\$ 53	Specify fabric color number.	
	• Fabric price group 7	+\$ 61	Specify fabric color number.	
	• Fabric price group 8	+\$ 77	Specify fabric color number.	
	• Fabric price group 9	+\$ 94	Specify fabric color number.	
	• Fabric price group 10	+\$107	Specify fabric color number.	
	• Steelcase leather upholstery	+\$312	Add suffix S to the style number and specify leather color number.	
	• Select Surfaces leather price group 1	+\$312	Add suffix S to the style number and specify leather color number.	
	• Elmosoft leather upholstery	+\$364	Add suffix S to the style number and specify leather color number.	
	• Select Surfaces leather price group 2	+\$364	Add suffix S to the style number and specify leather color number.	
	• Steelcase vinyl	+\$ 13	Add suffix S to the style number and specify vinyl color number.	
	• Customer's Own Material (COM)	No cost	► See <i>Surface Materials Reference Manual</i> .	
	• Customer's Own Leather (COL)	+\$188	Add suffix S to the style number and specify leather color number.	
	Soil-retardant treatment			
		+\$ 25	Specify with soil-retardant treatment.	
Casters	• Soft, dual-wheel casters or use on hard floors	+\$ 25	Specify with soft casters.	
Glides	• Stainless steel glides	+\$ 25	Specify with GLD453.	

► Specification Information, on next page

Seating

Criterion 453 Series Mid-Back Work Chairs, continued

SIN 711.18

► **Options, on previous page**

Specification Information

Height-, Width-, and Pivot-Adjustable Arms



• **Style Number**
:
:

• **Base Price**
:
:

Height- and Width-Adjustable Arms



• **Style Number**
:
:

• **Base Price**
:
:

Fixed-Height Arms



• **Style Number**
:
:

• **Base Price**
:
:

Soft Arm Caps

Pneumatic

4535330P \$1340

4535330W \$1434

4535330 \$1178

Pneumatic with Adjustable Seat Depth

4535330DP \$1453

4535330DW \$1547

4535330D \$1291

Without Arms



• **Style Number**
:
:

• **Base Price**
:
:

Pneumatic

4535300 \$1000

Pneumatic with Adjustable Seat Depth

4535300D \$1113

Criterion 453 Series High-Back Stools

SIN 711.18



► Need help?
Product details,
page 76

Standard Includes

- Back height adjustment
- Seat angle adjustment
- Variable back stop
- Back tension adjustment
- Arms, if selected: plastic color to match base
- Outer back and outer seat: plastic
- Upholstery: fabric price group 1
- Five-arm base: plastic
- Adjustable foot ring: plastic
- 2½"-diameter, hard composition, dual-wheel casters: black plastic

Required to Specify

- 1 Style number
 - 2 Plastic color number for base, foot ring, outer back, outer seat, and arms
 - 3 Fabric color number for upholstery
 - 4 Options, if selected (see below)
- See *Surface Materials*, page 432.

Tip: Leather and vinyl upcharges are in addition to sewn upholstery upcharge.

	Options	Price	Required to Specify
Surface Materials	Upholstery on seat and back		
	• Fabric price group 1	No cost	Specify fabric color number.
	• Fabric price group 2	+\$ 26	Specify fabric color number.
	• Fabric price group 3	+\$ 48	Specify fabric color number.
	• Fabric price group 4	+\$ 68	Specify fabric color number.
	• Fabric price group 5	+\$ 85	Specify fabric color number.
	• Fabric price group 6	+\$106	Specify fabric color number.
	• Fabric price group 7	+\$121	Specify fabric color number.
	• Fabric price group 8	+\$153	Specify fabric color number.
	• Fabric price group 9	+\$188	Specify fabric color number.
	• Fabric price group 10	+\$213	Specify fabric color number.
	• Steelcase leather upholstery	+\$623	Add suffix S to the style number and specify leather color number.
• Select Surfaces leather price group 1	+\$623	Add suffix S to the style number and specify Select Surfaces leather price group 1.	
• Elmosoft leather upholstery	+\$728	► See <i>Surface Materials Reference Manual</i> . Add suffix S to the style number and specify Elmosoft leather color number.	
• Select Surfaces leather price group 2	+\$728	Add suffix S to the style number and specify Select Surfaces leather price group 2.	
• Steelcase vinyl	+\$ 26	► See <i>Surface Materials Reference Manual</i> . Add suffix S to the style number and specify vinyl color number.	
• Customer's Own Material (COM)	No cost	► See <i>Surface Materials Reference Manual</i> to specify.	
• Customer's Own Leather (COL)	+\$376	Add suffix S to the style number and specify leather color number.	
	Fully upholstered		
• Outer back	+\$110	Add suffix B to the style number.	
	Height-adjustable foot ring		
• Polished Chrome foot ring	+\$ 41	Specify with 9201 Polished Chrome foot ring.	
	Sewn upholstery		
• Sewn upholstery applied	+\$ 51	Add suffix S to the style number.	
	Non-sewn seat upholstery		
• Non-sewn seat upholstery applied	+\$ 94	Add suffix X to the style number.	
	Contrasting upholstery on seat and back		
• Contrasting fabrics	+\$ 31	Add suffix K to the style number and specify fabric color numbers.	

► Options, continued on next page

Tip: Suffixes other than K for contrasting fabric, will be added in alphabetical order when specifying options. The contrasting fabric suffix, K, will always be at the end of the style number.

► Detailed dimensions,
page 80

► Options, continued from previous page

Options	Price	Required to Specify
Surface Materials, continued		
Contrasting upholstery on seat		
• Fabric price group 1	No cost	Specify fabric color number.
• Fabric price group 2	+\$ 13	Specify fabric color number.
• Fabric price group 3	+\$ 24	Specify fabric color number.
• Fabric price group 4	+\$ 34	Specify fabric color number.
• Fabric price group 5	+\$ 42	Specify fabric color number.
• Fabric price group 6	+\$ 53	Specify fabric color number.
• Fabric price group 7	+\$ 61	Specify fabric color number.
• Fabric price group 8	+\$ 76	Specify fabric color number.
• Fabric price group 9	+\$ 94	Specify fabric color number.
• Fabric price group 10	+\$106	Specify fabric color number.
• Steelcase leather upholstery	+\$311	Add suffix S to the style number and specify leather color number.
• Select Surfaces leather price group 1	+\$311	Add suffix S to the style number and specify leather color number.
• Elmosoft leather upholstery	+\$364	Add suffix S to the style number and specify leather color number.
• Select Surfaces leather price group 2	+\$364	Add suffix S to the style number and specify leather color number.
• Steelcase vinyl	+\$ 13	Add suffix S to the style number and specify vinyl color number.
• Customer's Own Material (COM)	No cost	► See <i>Surface Materials Reference Manual</i> .
• Customer's Own Leather (COL)	+\$188	Add suffix S to the style number and specify leather color number.
Contrasting upholstery on back		
• Fabric price group 1	No cost	Specify fabric color number.
• Fabric price group 2	+\$ 13	Specify fabric color number.
• Fabric price group 3	+\$ 24	Specify fabric color number.
• Fabric price group 4	+\$ 34	Specify fabric color number.
• Fabric price group 5	+\$ 43	Specify fabric color number.
• Fabric price group 6	+\$ 53	Specify fabric color number.
• Fabric price group 7	+\$ 61	Specify fabric color number.
• Fabric price group 8	+\$ 77	Specify fabric color number.
• Fabric price group 9	+\$ 94	Specify fabric color number.
• Fabric price group 10	+\$107	Specify fabric color number.
• Steelcase leather upholstery	+\$312	Add suffix S to the style number and specify leather color number.
• Select Surfaces leather price group 1	+\$312	Add suffix S to the style number and specify leather color number.
• Elmosoft leather upholstery	+\$364	Add suffix S to the style number and specify leather color number.
• Select Surfaces leather price group 2	+\$364	Add suffix S to the style number and specify leather color number.
• Steelcase vinyl	+\$ 13	Add suffix S to the style number and specify vinyl color number.
• Customer's Own Material (COM)	No cost	► See <i>Surface Materials Reference Manual</i> .
• Customer's Own Leather (COL)	+\$188	Add suffix S to the style number and specify leather color number.
Soil-retardant treatment	+\$ 25	Specify <i>with soil-retardant treatment</i> .
Casters		
• Soft, dual-wheel casters or use on hard floors	+\$ 25	Specify <i>with soft casters</i> .
Glides		
• Stainless steel glides	+\$ 25	Specify <i>with GLD453</i> .

► Specification Information, on next page

Tip: Leather and vinyl upcharges are in addition to sewn upholstery upcharge.

Seating

Criterion 453 Series High-Back Stools, continued

SIN 711.18

► **Options, on previous page**

Specification Information

Height-, Width-, and Pivot-Adjustable Arms



• **Style Number**
:
:

• **Base Price**
:
:

Height- and Width-Adjustable Arms



• **Style Number**
:
:

• **Base Price**
:
:

Fixed-Height Arms



• **Style Number**
:
:

• **Base Price**
:
:

Soft Arm Caps

Pneumatic

4537331P \$1679

4537331W \$1773

4537331 \$1517

Pneumatic with Adjustable Seat Depth

4537331DP \$1792

4537331DW \$1886

4537331D \$1630

Without Arms

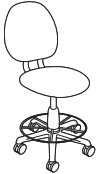

• **Style Number**
:
:

• **Base Price**
:
:

Pneumatic

4537301 \$1339

Pneumatic with Adjustable Seat Depth

4537301D \$1452

Criterion 453 Series Mid-Back Stools

SIN 711.18



► Need help?
Product details,
page 76

Standard Includes

- Back height adjustment
- Seat angle adjustment
- Variable back stop
- Back tension adjustment
- Arms, if selected: plastic color to match base
- Outer back and outer seat: plastic
- Upholstery: fabric price group 1
- Five-arm base: plastic
- Adjustable foot ring: plastic
- 2 1/8"-diameter, hard composition, dual-wheel casters: black plastic

Required to Specify

- 1 Style number
 - 2 Plastic color number for base, foot ring, outer back, outer seat, and arms
 - 3 Fabric color number for upholstery
 - 4 Options, if selected (see below)
- See *Surface Materials*, page 432.

Tip: Leather and vinyl upcharges are in addition to sewn upholstery upcharge.

	Options	Price	Required to Specify
Surface Materials	Upholstery		
	• Fabric price group 1	No cost	Specify fabric color number.
	• Fabric price group 2	+\$ 26	Specify fabric color number.
	• Fabric price group 3	+\$ 48	Specify fabric color number.
	• Fabric price group 4	+\$ 68	Specify fabric color number.
	• Fabric price group 5	+\$ 85	Specify fabric color number.
	• Fabric price group 6	+\$106	Specify fabric color number.
	• Fabric price group 7	+\$121	Specify fabric color number.
	• Fabric price group 8	+\$153	Specify fabric color number.
	• Fabric price group 9	+\$188	Specify fabric color number.
• Fabric price group 10	+\$213	Specify fabric color number.	
• Steelcase leather upholstery	+\$623	Add suffix S to the style number and specify leather color number.	
• Select Surfaces leather price group 1	+\$623	Add suffix S to the style number and specify Select Surfaces leather price group 1.	
		► See <i>Surface Materials Reference Manual</i> .	
	• Elmosoft leather upholstery	+\$728	Add suffix S to the style number and specify Elmosoft leather color number.
	• Select Surfaces leather price group 2	+\$728	Add suffix S to the style number and specify Select Surfaces leather price group 2.
		► See <i>Surface Materials Reference Manual</i> .	
	• Steelcase vinyl	+\$ 26	Add suffix S to the style number and specify vinyl color number.
		► See <i>Surface Materials Reference Manual</i> to specify.	
	• Customer's Own Material (COM)	No cost	Add suffix S to the style number and specify leather color number.
	• Customer's Own Leather (COL)	+\$376	
	Height-adjustable foot ring		
	• Polished Chrome foot ring	+\$ 41	Specify with 9201 Polished Chrome foot ring.
	Fully upholstered		
	• Outer back	+\$110	Add suffix B to the style number.
	Sewn upholstery		
	• Sewn upholstery applied	+\$ 51	Add suffix S to the style number.
	Non-sewn seat upholstery		
	• Non-sewn seat upholstery applied	+\$ 94	Add suffix X to the style number.
	Contrasting upholstery on seat and back		
	• Contrasting fabrics	+\$ 31	Add suffix K to the style number.

► Options, continued on next page

Tip: Non-sewn seat upholstery (**X** suffix) is available only on models with adjustable seat depth (**D** suffix).

Tip: Suffixes other than **K** for contrasting fabric, will be added in alphabetical order when specifying options. The contrasting fabric suffix, **K**, will always be at the end of the style number.

► Detailed dimensions, page 80

► Options, continued from previous page

Options	Price	Required to Specify
Surface Materials, continued		
Contrasting upholstery on seat		
• Fabric price group 1	No cost	Specify fabric color number.
• Fabric price group 2	+\$ 13	Specify fabric color number.
• Fabric price group 3	+\$ 24	Specify fabric color number.
• Fabric price group 4	+\$ 34	Specify fabric color number.
• Fabric price group 5	+\$ 42	Specify fabric color number.
• Fabric price group 6	+\$ 53	Specify fabric color number.
• Fabric price group 7	+\$ 61	Specify fabric color number.
• Fabric price group 8	+\$ 76	Specify fabric color number.
• Fabric price group 9	+\$ 94	Specify fabric color number.
• Fabric price group 10	+\$106	Specify fabric color number.
• Steelcase leather upholstery	+\$311	Add suffix S to the style number and specify leather color number.
• Select Surfaces leather price group 1	+\$311	Add suffix S to the style number and specify leather color number.
• Elmosoft leather upholstery	+\$364	Add suffix S to the style number and specify leather color number.
• Select Surfaces leather price group 2	+\$364	Add suffix S to the style number and specify leather color number.
• Steelcase vinyl	+\$ 13	Add suffix S to the style number and specify vinyl color number.
• Customer's Own Material (COM)	No cost	► See <i>Surface Materials Reference Manual</i> .
• Customer's Own Leather (COL)	+\$188	Add suffix S to the style number and specify leather color number.
Contrasting upholstery on back		
• Fabric price group 1	No cost	Specify fabric color number.
• Fabric price group 2	+\$ 13	Specify fabric color number.
• Fabric price group 3	+\$ 24	Specify fabric color number.
• Fabric price group 4	+\$ 34	Specify fabric color number.
• Fabric price group 5	+\$ 43	Specify fabric color number.
• Fabric price group 6	+\$ 53	Specify fabric color number.
• Fabric price group 7	+\$ 61	Specify fabric color number.
• Fabric price group 8	+\$ 77	Specify fabric color number.
• Fabric price group 9	+\$ 94	Specify fabric color number.
• Fabric price group 10	+\$107	Specify fabric color number.
• Steelcase leather upholstery	+\$312	Add suffix S to the style number and specify leather color number.
• Select Surfaces leather price group 1	+\$312	Add suffix S to the style number and specify leather color number.
• Elmosoft leather upholstery	+\$364	Add suffix S to the style number and specify leather color number.
• Select Surfaces leather price group 2	+\$364	Add suffix S to the style number and specify leather color number.
• Steelcase vinyl	+\$ 13	Add suffix S to the style number and specify vinyl color number.
• Customer's Own Material (COM)	No cost	► See <i>Surface Materials Reference Manual</i> .
• Customer's Own Leather (COL)	+\$188	Add suffix S to the style number and specify leather color number.
Soil-retardant treatment	+\$ 25	Specify <i>with soil-retardant treatment</i> .
Casters		
• Soft, dual-wheel casters or use on hard floors	+\$ 25	Specify <i>with soft casters</i> .
Glides		
• Stainless steel glides	+\$ 25	Specify <i>with GLD453</i> .

► Specification Information, on next page

Tip: Leather and vinyl upcharges are in addition to sewn upholstery upcharge.

Seating

Criterion 453 Series Mid-Back Stools, continued

SIN 711.18

► **Options, on previous page**

Specification Information

Height-, Width-, and Pivot-Adjustable Arms



• **Style Number**
 :
 :
 :
 :
 :
 :
 :
 :
 :

• **Base Price**
 :
 :
 :
 :
 :
 :
 :
 :

Height- and Width-Adjustable Arms



• **Style Number**
 :
 :
 :
 :
 :
 :
 :
 :

• **Base Price**
 :
 :
 :
 :
 :
 :
 :
 :

Fixed-Height Arms



• **Style Number**
 :
 :
 :
 :
 :
 :
 :
 :

• **Base Price**
 :
 :
 :
 :
 :
 :
 :
 :

Soft Arm Caps

Pneumatic

4537330P \$1613

4537330W \$1707

4537330 \$1451

Pneumatic with Adjustable Seat Depth

4537330DP \$1726

4537330DW \$1820

4537330D \$1564

Without Arms

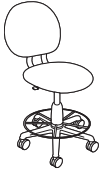

• **Style Number**
 :
 :
 :
 :
 :
 :
 :
 :

• **Base Price**
 :
 :
 :
 :
 :
 :
 :
 :

Pneumatic

4537300 \$1273

Pneumatic with Adjustable Seat Depth

4537300D \$1386

Criterion Plus 453 Series High-Back Work Chairs

SIN 711.18



Tip: Criterion Plus is available with a fully-upholstered outer back only.

Tip: Height-, width-, and pivot-adjustable arms are not available on Criterion Plus.

Standard Includes		Required to Specify
<ul style="list-style-type: none"> ▶ Need help? Product details, page 76 	<ul style="list-style-type: none"> • Back height adjustment • Seat angle adjustment • Manual seat depth adjustment • Back tension adjustment • Upright back lock • Arms, if selected: plastic color to match base • Sewn upholstery • Upholstery: fabric price group 1 • Outer back: upholstery • Outer seat: plastic color • Five-arm base: plastic color • 2½"-diameter, hard composition, dual-wheel casters: black plastic 	<ol style="list-style-type: none"> 1 Style number 2 Plastic color number for base, outer seat, and arms 3 Fabric color number for upholstery 4 Options, if selected (see below) <p>▶ See <i>Surface Materials</i>, page 432.</p>

Options	Price	Required to Specify
Surface Materials	Upholstery on seat and back	
<ul style="list-style-type: none"> • Fabric price group 1 • Fabric price group 2 • Fabric price group 3 • Fabric price group 4 • Fabric price group 5 • Fabric price group 6 • Fabric price group 7 • Fabric price group 8 • Fabric price group 9 • Fabric price group 10 • Steelcase leather upholstery • Select Surfaces leather price group 1 • Elmosoft leather upholstery • Select Surfaces leather price group 2 • Steelcase vinyl • Customer's Own Material (COM) • Customer's Own Leather (COL) 	<ul style="list-style-type: none"> No cost +\$ 26 +\$ 48 +\$ 68 +\$ 85 +\$106 +\$121 +\$153 +\$188 +\$213 +\$325 +\$325 +\$374 +\$374 +\$ 26 No cost +\$ 37 	<ul style="list-style-type: none"> Specify fabric color number. Specify fabric color number. Specify fabric color number. Specify fabric color number. Specify fabric color number. Specify fabric color number. Specify fabric color number. Specify fabric color number. Specify fabric color number. Specify fabric color number. Specify leather color number. ▶ See <i>Surface Materials Reference Manual</i>. Specify Elmosoft leather color number. ▶ See <i>Surface Materials Reference Manual</i>. Specify vinyl color number. ▶ See <i>Surface Materials Reference Manual</i> to specify. ▶ See <i>Surface Materials Reference Manual</i> to specify.
	Contrasting upholstery on seat and back	
<ul style="list-style-type: none"> • Contrasting fabrics 	<ul style="list-style-type: none"> +\$ 31 	<ul style="list-style-type: none"> Add suffix K to the style number and specify fabric color numbers.
	Contrasting upholstery on seat	
<ul style="list-style-type: none"> • Fabric price group 1 • Fabric price group 2 • Fabric price group 3 • Fabric price group 4 • Fabric price group 5 • Fabric price group 6 • Fabric price group 7 • Fabric price group 8 • Fabric price group 9 • Fabric price group 10 • Steelcase leather upholstery • Select Surfaces leather price group 1 • Elmosoft leather upholstery • Select Surfaces leather price group 1 • Steelcase vinyl • Customer's Own Material (COM) • Customer's Own Leather (COL) 	<ul style="list-style-type: none"> No cost +\$ 13 +\$ 24 +\$ 34 +\$ 42 +\$ 53 +\$ 61 +\$ 76 +\$ 94 +\$106 +\$162 +\$162 +\$186 +\$186 +\$ 13 No cost +\$ 19 	<ul style="list-style-type: none"> Specify fabric color number. Specify fabric color number. Specify fabric color number. Specify fabric color number. Specify fabric color number. Specify fabric color number. Specify fabric color number. Specify fabric color number. Specify fabric color number. Specify fabric color number. Specify leather color number. Specify leather color number. Specify leather color number. Specify leather color number. Specify leather color number. Specify leather color number. Specify leather color number. Specify leather color number. Specify vinyl color number. ▶ See <i>Surface Materials Reference Manual</i>. Specify leather color number.

▶ Options, continued on next page

▶ Detailed dimensions, page 80

► Options, continued from previous page

Options	Price	Required to Specify
Surface Materials, continued	Contrasting upholstery on back	
• Fabric price group 1	No cost	Specify fabric color number.
• Fabric price group 2	+\$ 13	Specify fabric color number.
• Fabric price group 3	+\$ 24	Specify fabric color number.
• Fabric price group 4	+\$ 34	Specify fabric color number.
• Fabric price group 5	+\$ 43	Specify fabric color number.
• Fabric price group 6	+\$ 53	Specify fabric color number.
• Fabric price group 7	+\$ 61	Specify fabric color number.
• Fabric price group 8	+\$ 77	Specify fabric color number.
• Fabric price group 9	+\$ 94	Specify fabric color number.
• Fabric price group 10	+\$107	Specify fabric color number.
• Steelcase leather upholstery	+\$163	Specify leather color number.
• Select Surfaces leather price group 1	+\$163	Specify leather color number.
• Elmosoft leather upholstery	+\$187	Specify leather color number.
• Select Surfaces leather price group 2	+\$187	Specify leather color number.
• Steelcase vinyl	+\$ 13	Specify vinyl color number.
• Customer's Own Material (COM)	No cost	► See <i>Surface Materials Reference Manual</i> .
• Customer's Own Leather (COL)	+\$ 19	Specify vinyl color number.
	Soil-retardant treatment	
	+\$ 25	Specify with soil-retardant treatment.
Casters	• Soft, dual-wheel casters for use on hard floors	+\$ 25
		Specify with soft casters.

Specification Information

Height- and Width-Adjustable Arms



• Style Number
• Base Price

Fixed-Height Arms



• Style Number
• Base Price

Soft Arm Caps

Pneumatic

4539331BW	\$2353	4539331B	\$2167
------------------	--------	-----------------	--------



• Style Number
• Base Price

Without Arms

Pneumatic

4539301B	\$1989
-----------------	--------

Criterion 453 Series

Think 465 Series

Think is for performance based customers who are seeking a progressive aesthetic, intuitive ease of use, and the strongest environmental attributes.

Back frame and seat shell are plastic.

Lumbar height adjusts over 4 1/4" to provide additional lower back support and is available as an option.

Arm caps can pivot independently 30° in and 30° out to accommodate individual user preferences.

Comfort dial back control provides four settings for the user's personal preference and work style.

Seat height adjusts within a 5" range with a pneumatic adjustment mechanism. A 3" or 7" range is available as an option. Stools have a 10" range.

Casters have hard, dual-wheels that roll smoothly on carpets. They are 2 1/2" for increased mobility. Soft, dual-wheel roll-control casters are available as an option for use on hard floors or chair mats. Glides are also available as an option.

Tip: Do not roll the chair across asphalt during installation as this may damage the casters.

Arm width adjusts 4 1/2" overall to support forearms in neutral position.

Arm height can adjust independently within a 4" range to help relieve upper back and shoulder fatigue.

Arm depth can retract 3" to allow user to get closer to the worksurface and into tight corners.

Passive seat edge angle allows the front edge of the seat to flex 1 1/2" to relieve pressure under the user's thighs.

Seat depth adjusts within a 2 1/2" range to accommodate users of varying leg lengths.

Five-arm base is available in plastic or polished aluminum.



Product Details

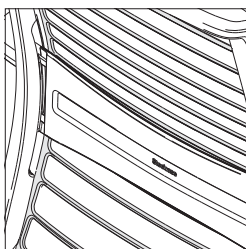

Integrated LiveBack System dynamically supports and follows the movements of the user.

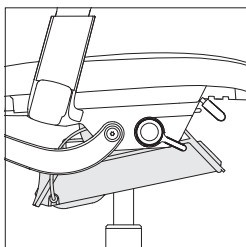

Advanced weight-activated mechanism with a natural fluid motion keeps users oriented to their work.

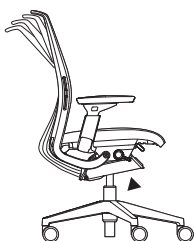

Comfort dial has four settings that allow for the user's personal preference and work style.

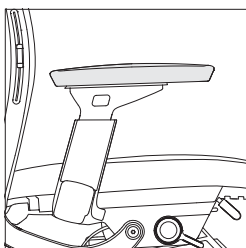

Rectilinear arms with soft caps are standard.

Cartoned request on your dealer purchase order means Think chairs will ship knocked down with the chair base and pneumatic cylinder separated from the rest of the chair. This allows for shipment in a smaller carton. Assembly by a qualified dealer installer is required. *Tip: Assembly instructions are included.*

Uncartoned request on your dealer purchase order means Think chairs will ship fully assembled.

Adjustment Features

Adjustability instructions are included with every chair.

Seat Adjustments

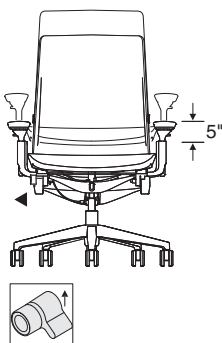

Seat height adjusts pneumatically. To lower, hold handle up while seated. To raise, hold handle up and keep your weight off the chair. Standard range of adjustability is 5" from 16½"H to 21½"H. A 3" range of adjustability (15"H to 18"H), and a 7" range of adjustability (18"H to 25"H) is available as an option. A 10" range of adjustability (22½"H to 32½"H) is available on stools.

Passive seat edge angle relieves pressure under the user's thighs. The passive front seat edge helps properly support the angle of the user's leg and thigh without compromising pelvic support. The front seat edge angle flexes 1½".

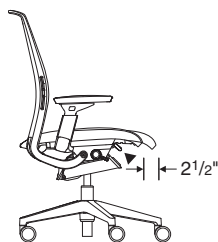

Seat depth adjusts 2½" (15½"-18") by pulling handle up. Slide seat forward or back to accommodate various leg lengths. Release handle to lock.

Back Adjustments

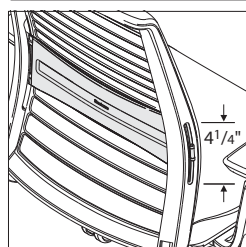

Lumbar height adjusts 4¼" (6" to 10¼" from seat) by grabbing exposed tabs and sliding the lumbar support up or down. Fixed lumbar height is available as an option on work chairs and stools. The fixed lumbar is positioned 8" from the seat. The adjustment handles are replaced with inserts that fill the lumbar slot in the back frame.



Weight-activated setting Boosted setting



Mid-stop recline setting Upright setting

Comfort dial has four settings: (1) weight-activated setting; (2) boosted setting that has approximately 20% more resistance than your body is providing; (3) mid-stop recline setting; and (4) an upright setting.

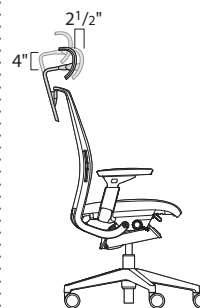

Headrest (option) adjusts 4" vertically and 2½" horizontally (front-to-back) to support the head and neck of the user in both upright and recline postures. The plastic stalk and underside of the headrest will coordinate to match the frame color specified: black, platinum, or seagull. The foam pad of the headrest will always be black. Headrest is not available on stools. Whether ordered initially or at a later date, the headrest ships in its own carton and must be field installed.

Arm Adjustments

Rectilinear height-, width-, pivot-, and depth-adjustable arms come standard on all arm models of chairs and stools.

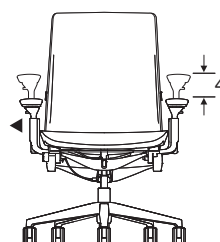

Arm height adjusts independently within a range of 4" (7"-11" from the seat). Push button on outside and under arm cap in while moving arms up or down. Releasing buttons locks arms in position.

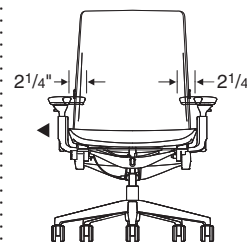

Arm width can be adjusted 2¼" each, 4½" overall. Grasp arm cap and move in or out.

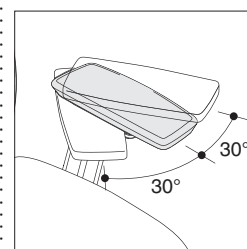

Arms pivot independently, 30° inward and outward. Grasp arm and push front to left or right.

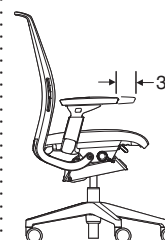

Arm depth adjusts by sliding arm caps back 3". Friction-fit mechanism keeps arms in position.

Think 465 Series, continued

Other Features

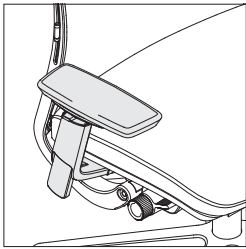

Height-only adjustable arm is also available and adjusts 4".



Armless models are also available.



Coat hanger (option) is field installed. The color will coordinate with the frame of the chair, but will not match the frame exactly. The coat hanger supports up to 10 pounds and is not intended to hold bags or backpacks. This option is not available on stools.

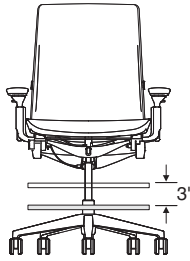

Foot ring height on stools adjusts by rotating it counterclockwise to unlock. Then raise or lower ring to desired position before rotating it clockwise to lock. The foot ring has a diameter of 20".

Soft dual-wheel roll-control casters feature an internal brake that activates when the chair is not under load to reduce shifting when user stands up.

Surface Materials

▶ See surface materials on page 432 for specific availability or refer to the *Surface Materials Reference Manual* for further information.

Upholstery

- Fabric
- Fabric with soil-retardant treatment (option)
- 3D Knit (back only)
- Elmosoft leather
- Select Surfaces leather
- Leather
- Vinyl

Hard components

- All models (backframe, arm retainer, and base)
- 4799 Platinum Metallic (Platinum and Seagull frame)
 - 6205 Black
 - 7243 Seagull

Pneumatic cylinders and stool ring finishes are determined by the frame finish.

- 4799 Platinum Metallic (Platinum and Seagull frame)
- 6205 Black (Black frame)

- All models (adjustment handles, arm pads, arm stalk, casters, glides)
- 6205 Black

Flexors and lumbar finishes are determined by the frame finish.

- 6205 Black (Black Frame)
- 6527 Merle (Platinum and Seagull Frames)

Outer seat shell is determined by the frame finish.

- 6205 Black (Black Frame)
- 6249 Platinum Solid (Platinum and Seagull Frames)

Inner seat shell

- 6205 Black

All seat cushions have a unique sewn construction that is included in the price of the chair.



Stitch detail across the lumbar region of the back cushion will be required on some models with an upholstered backrest. To ensure optimum performance of the Integrated LiveBack System, all Steelcase Select Surfaces, COMs, Leathers, Vinyls, and some standard fabrics will require this sewn detail. The stitch detail is included in the price of the chair.

All Steelcase seating with standard upholstery fabrics

complies with requirements of the State of California Technical Bulletin 117-2013. All standard seating is labeled to be in compliance with California 117-2013.

Programs & Services

▶ See *Surface Materials Reference Manual* for further detail about programs and services offered for seating.

The Customer's Own Material (COM) Program

offers the opportunity for customers to select fabrics that are not offered through the standard Steelcase surface materials program for use on Steelcase products. Through the COM program, Steelcase will test your materials for application on Steelcase products. Once approved, you can place your order. Steelcase will facilitate the entire ordering process and give you a production schedule. Steelcase will order the COM fabric directly from the textile manufacturer. For up-to-date information regarding fabric test results for all COM fabrics and details regarding yardage requirements for most seating lines, visit the COM website. To locate the COM website:

- Visit www.steelcase.com

Soil retardants are treatments that provide long-term soil and stain resistance to a fabric without affecting the shade or the integrity of the fabric. The following Steelcase Textiles are available pre-treated with soil retardant. (You do not need to select the soil-retardant option for these fabrics and incur the upcharge.)

- Jacks
- Link
- Spyder

For information on soil retardant fabrics on Select Surfaces, please refer to the *Surface Materials Reference Manual*.

Soil-retardant treatment is available on all other seating fabrics at an additional upcharge per seating unit. To order this option, please select "Soil-Retardant Treatment" under "Optional Accessories."

For soil-retardant treatment on COMs, please select "Soil-Retardant Treatment" under "Optional Accessories". Minimums or additional yardage may be required. Please contact the vendor directly for specific information.

Extended lead times may be necessary for this service.

Contact your Steelcase Solutions Fulfillment Team Representative at 1.888.STEELCASE (1.888.783.3522) or send an email to lineone@steelcase.com.

Fire Codes

▶ See page 462 for upholstery fabrics available for use with FCS modification.

Steelcase offers Fire Code Seating modification (FCS) on some seating models. The most rigorous fire codes in the nation have been developed in California, and the Steelcase FCS modification is designed to meet those codes. Fire Code Seating (FCS) indicates that a product is constructed to meet the strict fire code requirements of high public occupancy areas such as theaters, meeting rooms, and lobbies. The FCS standards will meet the State of California Bureau of Electronic and Appliance Repair, Home Furnishings, and Thermal Insulation Technical Bulletin 133 (Cal TB 133). Boston adopted the California Bureau of Electronic and Appliance Repair, Home Furnishings, and Thermal Insulation Technical Bulletin TB 133 test standard in 1992.

Local codes may have special requirements for upholstery.

Dimensions

▶ Page 104

Think Upholstery

What Is It?

Fabric, leather, or vinyl-covered back and seat, 3D Knit back.

Fabric

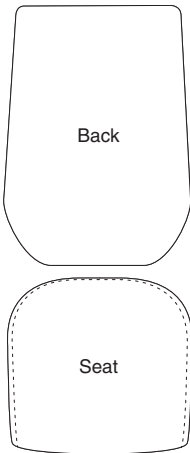

Leather, Vinyl, and Select Other Fabrics

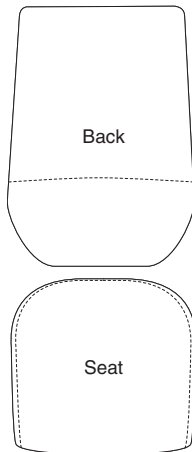

3D Knit on Back only

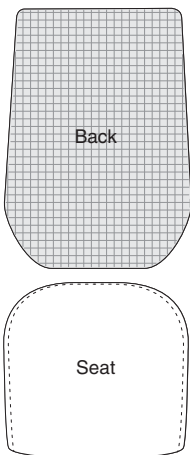

Stitched seams are included on the back cushion and seat cushion of the following:

- Leather
- Vinyl
- Some upholstery
- Customer's Own Leather (COL)
- Vinyl
- Select Customer's Own Material/Vinyl (COM)

Pattern alignment at the lumbar seam cannot be guaranteed.

3D Knit back with Fire Code option

is made up of three layers: the 3D Knit, a fire code barrier, and a solid fabric that matches the 3D Knit color (which will be visible through the back flexors). The 3D Knit fire code back rest is not transparent.

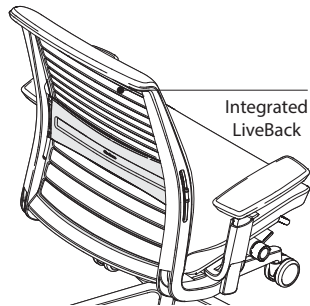

Back flexors are fully exposed.

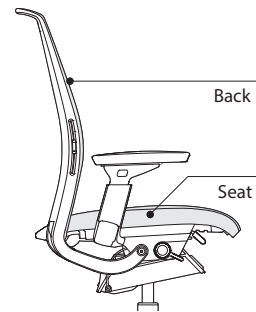

Seat and back assemblies can be removed and replaced if damaged.

Dimensions

Think 465 Series

Features	Overall Depth	Width	Height	Seat Depth	Functional Seat Depth	Seat Width	Seat Height from Floor	Ring Height from Floor	Back Width	Back Height from Seat
----------	---------------	-------	--------	------------	-----------------------	------------	------------------------	------------------------	------------	-----------------------

Think 465 Series

Chairs

Arms	22"-24 ¹ / ₄ "	28 ¹ / ₂ "	37 ¹ / ₄ "-42"	18 ¹ / ₂ "	15 ¹ / ₂ "-18"	20 ¹ / ₄ "	16 ¹ / ₂ "-21 ¹ / ₂ " (15"-18", 18"-25" optional)	N.A.	18"	22 ³ / ₄ "
------	--------------------------------------	----------------------------------	--------------------------------------	----------------------------------	--------------------------------------	----------------------------------	--	------	-----	----------------------------------

Stools

Arms	22"-24 ¹ / ₄ "	28 ¹ / ₂ "	44"-53 ³ / ₄ "	18 ¹ / ₂ "	15 ¹ / ₂ "-18"	20 ¹ / ₄ "	22 ¹ / ₂ "-32 ¹ / ₂ "	10"-13"	18"	22 ³ / ₄ "
------	--------------------------------------	----------------------------------	--------------------------------------	----------------------------------	--------------------------------------	----------------------------------	---	---------	-----	----------------------------------

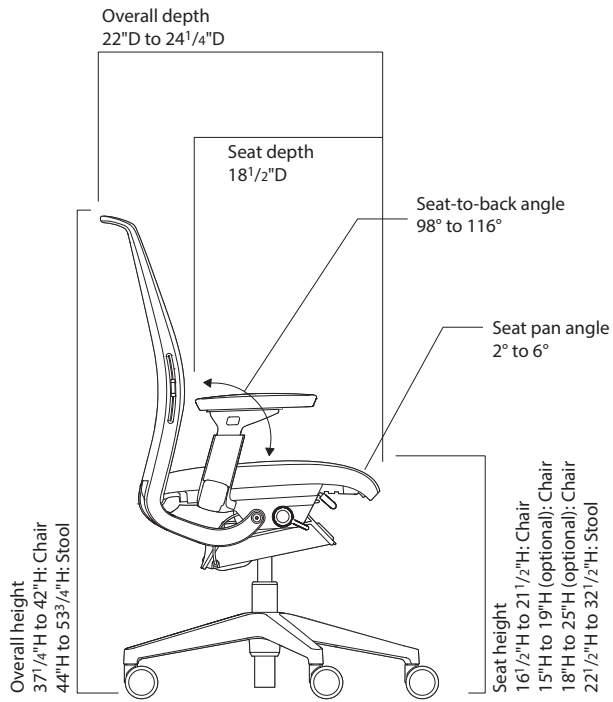
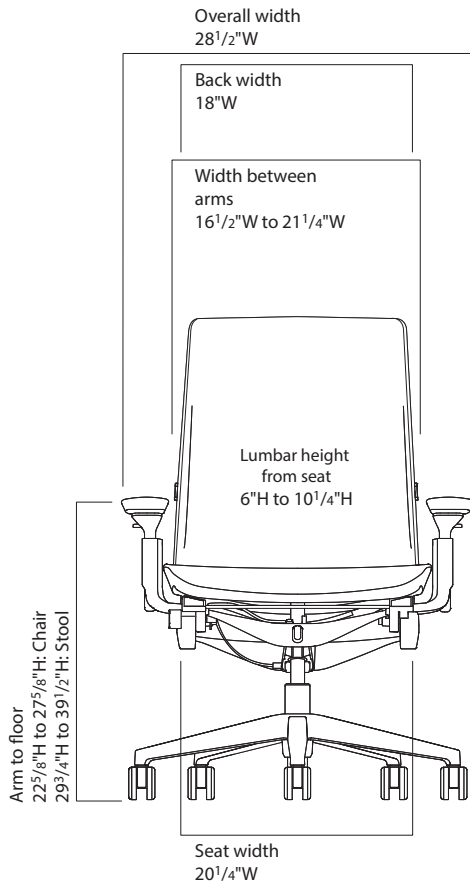

• Lumbar Height from Seat	• Width Between Adjustable Arms	• Width Between Fixed Arms	• Arm to Floor	• Arm Height from Seat	• Arm Height from Seat for Fixed Arms	• Arm Cap Pivot Range	• Angle Between Seat and Back	• Seat Pan Angle	• Headrest Height Adjustment Range
---------------------------	---------------------------------	----------------------------	----------------	------------------------	---------------------------------------	-----------------------	-------------------------------	------------------	------------------------------------

Chairs

6"–10¼"	16½"–21¼" 14"–21¼" (including pivot)	20½"	22⅝"–27⅝"	7"–11"	8¼"	30° inward, 30° outward	98°–116°	2°–6°	4"
---------	--	------	-----------	--------	-----	----------------------------	----------	-------	----

Stools

6"–10¼"	16½"–21¼" 14"–21¼" (including pivot)	20½"	29¾"–39½"	7"–11"	8¼"	30° inward, 30° outward	98°–116°	2°–6°	N.A.
---------	--	------	-----------	--------	-----	----------------------------	----------	-------	------

Think 465 Series Work Chairs

3D Knit with Standard Upholstery on Seat

SIN 711.18



	Standard Includes	Required to Specify
► Need help? Product details, page 100	<ul style="list-style-type: none"> 5" pneumatic seat-height adjustment (16½"–21½") Passive seat edge angle Frame, seat shell, and five-arm plastic base: black 2½" seat depth adjustment Rectilinear height-, width-, pivot-, and depth-adjustable arms Adjustable lumbar 3D Knit on back Standard upholstery design on seat: fabric price group 1 2½"-diameter, hard-composition, dual-wheel casters: black 	<ol style="list-style-type: none"> Style number Plastic color for frame, base, and arm retainer 3D Knit color for back Fabric color number for upholstery on seat Options, if selected (see below) <p>► See <i>Surface Materials</i>, page 432.</p>

	Options	Price	Required to Specify
Surface Materials	Upholstery		
	• Fabric price group 1	No cost	Specify fabric color number.
	• Fabric price group 2	+\$ 10	Specify fabric color number.
	• Fabric price group 3	+\$ 24	Specify fabric color number.
	• Fabric price group 4	+\$ 33	Specify fabric color number.
	• Fabric price group 5	+\$ 42	Specify fabric color number.
	• Fabric price group 6	+\$ 51	Specify fabric color number.
	• Fabric price group 7	+\$ 58	Specify fabric color number.
	• Fabric price group 8	+\$ 76	Specify fabric color number.
	• Fabric price group 9	+\$ 93	Specify fabric color number.
	• Fabric price group 10	+\$106	Specify fabric color number.
	• Steelcase leather upholstery	+\$163	Specify leather color number.
	• Select Surfaces leather price group 1	+\$163	► See <i>Surface Materials Reference Manual</i> . Specify Elmosoft leather color number.
	• Elmosoft leather upholstery	+\$191	► See <i>Surface Materials Reference Manual</i> .
• Select Surfaces leather price group 2	+\$191	► See <i>Surface Materials Reference Manual</i> .	
• Customer's Own Material (COM)	No cost	► See <i>Surface Materials Reference Manual</i> .	
	Soil-retardant treatment	+\$ 25	Specify with soil-retardant treatment.
	Fire Code Seating (FCS)	+\$ 39	Specify with fire code seating.
	Frame		
	• Platinum	+\$ 48	Specify with 4799 Platinum.
	• Seagull	+\$ 48	Specify with 7243 Seagull.
Arms	• Height-adjustable arms	–\$ 49	Specify with height-adjustable arms.
	• Fixed arms	–\$ 99	Specify with fixed arms.
	• Armless	–\$253	Specify without arms.
Base	• Polished aluminum base	+\$140	Specify with aluminum base.
Coat Hanger	• Coat hanger	+\$ 30	Specify with coat hanger.
Seat Height	• 3" low-range pneumatic seat-height adjustment (15"–18")	+\$ 58	Specify with low-range pneumatic seat-height adjustment.
	• 7" high-range pneumatic seat-height adjustment (18"–25")	+\$ 58	Specify with high-range pneumatic seat-height adjustment.
Headrest	• Headrest	+\$170	Specify with headrest.
Lumbar	• Fixed lumbar support	–\$ 57	Specify with fixed lumbar height.
Casters	• Soft, dark grey treaded, dual-wheel roll-control casters for use on hard floors	+\$ 25	Specify with soft roll-control casters.
Glides	• Glides: plastic	+\$ 25	Specify with glides.

Tip: Fire Code Seating (FCS) option is available with certain upholstery fabric choices only.
► Page 462

Tip: Fire Code Seating (FCS) option is available on Think chairs with fully adjustable arms or armless models only.

Tip: Coat hanger option is not available on chairs with headrest.

Tip: Plastic shell on headrest is available in black only.

► Detailed dimensions, page 104

Specification Information

Style Number	Base Price
465A300	\$1258



Think 465 Series Work Chairs

Standard Upholstery on Back and Seat

SIN 711.18



Standard Includes	Required to Specify
<ul style="list-style-type: none"> ▶ Need help? Product details, page 100 • 5" pneumatic seat-height adjustment (16½"–21½") • Passive seat edge angle • Frame, seat shell, and five-arm plastic base: black • 2½" seat depth adjustment • Rectilinear height-, width-, pivot-, and depth-adjustable arms • Adjustable lumbar • Standard upholstery design: fabric price group 1 • 2½"-diameter, hard-composition, dual-wheel casters: black 	<ol style="list-style-type: none"> 1 Style number 2 Plastic color for frame, base, and arm retainer 3 Fabric color number for upholstery on seat and back 4 Options, if selected (see below) <p>▶ See <i>Surface Materials</i>, page 432.</p>

Surface Materials	Options	Price	Required to Specify
	Contrasting		
	• Contrasting fabrics	+\$ 31	Specify <i>with contrasting</i> .
	Upholstery on seat		
	• Fabric price group 1	No cost	Specify fabric color number.
	• Fabric price group 2	+\$ 10	Specify fabric color number.
	• Fabric price group 3	+\$ 24	Specify fabric color number.
	• Fabric price group 4	+\$ 33	Specify fabric color number.
	• Fabric price group 5	+\$ 42	Specify fabric color number.
	• Fabric price group 6	+\$ 51	Specify fabric color number.
	• Fabric price group 7	+\$ 58	Specify fabric color number.
• Fabric price group 8	+\$ 76	Specify fabric color number.	
• Fabric price group 9	+\$ 93	Specify fabric color number.	
• Fabric price group 10	+\$106	Specify fabric color number.	
• Steelcase leather upholstery	+\$163	Specify leather color number.	
• Select Surfaces leather price group 1	+\$163	▶ See <i>Surface Materials Reference Manual</i> .	
• Elmosoft leather upholstery	+\$191	Specify Elmosoft leather color number.	
• Select Surfaces leather price group 2	+\$191	▶ See <i>Surface Materials Reference Manual</i> .	
• Customer's Own Material (COM)	No cost	▶ See <i>Surface Materials Reference Manual</i> .	
	Upholstery on back		
	• Fabric price group 1	No cost	Specify fabric color number.
	• Fabric price group 2	+\$ 14	Specify fabric color number.
	• Fabric price group 3	+\$ 26	Specify fabric color number.
	• Fabric price group 4	+\$ 35	Specify fabric color number.
	• Fabric price group 5	+\$ 43	Specify fabric color number.
	• Fabric price group 6	+\$ 53	Specify fabric color number.
	• Fabric price group 7	+\$ 62	Specify fabric color number.
	• Fabric price group 8	+\$ 77	Specify fabric color number.
	• Fabric price group 9	+\$ 94	Specify fabric color number.
• Fabric price group 10	+\$109	Specify fabric color number.	
• Steelcase leather upholstery	+\$171	Specify leather color number.	
• Select Surfaces leather price group 1	+\$171	▶ See <i>Surface Materials Reference Manual</i> .	
• Elmosoft leather upholstery	+\$197	Specify Elmosoft leather color number.	
• Select Surfaces leather price group 2	+\$197	▶ See <i>Surface Materials Reference Manual</i> .	
• Customer's Own Material (COM)	No cost	▶ See <i>Surface Materials Reference Manual</i> .	
	Soil-retardant treatment	+\$ 25	Specify <i>with soil-retardant treatment</i> .
	Fire Code Seating (FCS)	+\$ 77	Specify <i>with fire code seating</i> .
	Frame		
	• Platinum	+\$ 48	Specify <i>with 4799 Platinum</i> .
	• Seagull	+\$ 48	Specify <i>with 7243 Seagull</i> .
	Arms		
	• Height-adjustable arms	–\$ 49	Specify <i>with height-adjustable arms</i> .
	• Fixed arms	–\$ 99	Specify <i>with fixed arms</i> .
	• Armless	–\$253	Specify <i>without arms</i> .
	Base		
	• Polished aluminum base	+\$140	Specify <i>with aluminum base</i> .
	Coat Hanger		
	• Coat hanger	+\$ 30	Specify <i>with coat hanger</i> .

▶ Options, continued on next page

Tip: Fire Code Seating (FCS) option is available with certain upholstery fabric choices only.
▶ Page 462

Tip: Fire Code Seating (FCS) option is available on Think chairs with fully adjustable arms or armless models only.

Tip: Coat hanger option is not available on chairs with headrest.

▶ Detailed dimensions, page 104

SIN 711.18

► Options, continued from previous page

	Options	Price	Required to Specify
Seat Height	• 3" low-range pneumatic seat-height adjustment (15"–18")	+\$ 58	Specify with low-range pneumatic seat-height adjustment.
	• 7" high-range pneumatic seat-height adjustment (18"–25")	+\$ 58	Specify with high-range pneumatic seat-height adjustment.
Headrest	• Headrest	+\$170	Specify with headrest.
Lumbar	• Fixed lumbar support	–\$ 57	Specify with fixed lumbar height.
Casters	• Soft, dark grey treaded, dual-wheel roll-control casters for use on hard floors	+\$ 25	Specify with soft roll-control casters.
Glides	• Glides: plastic	+\$ 25	Specify with glides.

Tip: Plastic shell on headrest is available in black only.

Specification Information

Style Number	Base Price
465A000	\$1200



Think 465 Series Stool

3D Knit with Standard Upholstery on Seat

SIN 711.18



Standard Includes		Required to Specify
<ul style="list-style-type: none"> ▶ Need help? Product details, page 100 	<ul style="list-style-type: none"> • 10" pneumatic seat-height adjustment (22½"-32½") • Passive seat edge angle • Frame, seat shell, and five-arm base: black • 2½" seat depth adjustment • Rectilinear height-, width-, pivot-, and depth-adjustable arms • Column and adjustable foot ring: black • Adjustable lumbar • 3D Knit on back • Standard upholstery design on seat: fabric price group 1 • 2½"-diameter, hard-composition, dual-wheel casters: black 	<ol style="list-style-type: none"> 1 Style number 2 Plastic color for frame, base, and arm retainer 3 3D Knit color for back 4 Fabric color number for upholstery on seat 5 Options, if selected (see below) <ul style="list-style-type: none"> ▶ See <i>Surface Materials</i>, page 432.

Options		Price	Required to Specify
Surface Materials	Upholstery		
	• Fabric price group 1	No cost	Specify fabric color number.
	• Fabric price group 2	+\$ 10	Specify fabric color number.
	• Fabric price group 3	+\$ 24	Specify fabric color number.
	• Fabric price group 4	+\$ 33	Specify fabric color number.
	• Fabric price group 5	+\$ 42	Specify fabric color number.
	• Fabric price group 6	+\$ 51	Specify fabric color number.
	• Fabric price group 7	+\$ 58	Specify fabric color number.
	• Fabric price group 8	+\$ 76	Specify fabric color number.
	• Fabric price group 9	+\$ 93	Specify fabric color number.
	• Fabric price group 10	+\$106	Specify fabric color number.
	• Steelcase leather upholstery	+\$163	Specify leather color number.
	• Select Surfaces leather price group 1	+\$163	▶ See <i>Surface Materials Reference Manual</i> .
	• Elmosoft leather upholstery	+\$191	Specify Elmosoft leather color number.
	• Select Surfaces leather price group 2	+\$191	▶ See <i>Surface Materials Reference Manual</i> .
	• Customer's Own Material (COM)	No cost	▶ See <i>Surface Materials Reference Manual</i> .
	Soil-retardant treatment	+\$ 25	Specify with soil-retardant treatment.
	Fire Code Seating (FCS)	+\$ 39	Specify with fire code seating.
	Frame		
	• Platinum	+\$ 48	Specify with 4799 Platinum.
	• Seagull	+\$ 48	Specify with 7243 Seagull.
Arms	• Height-adjustable arms	-\$ 49	Specify with height-adjustable arms.
	• Fixed arms	-\$ 99	Specify with fixed arms.
	• Armless	-\$253	Specify without arms.
Base	• Polished aluminum base	+\$140	Specify with aluminum base.
Lumbar	• Fixed lumbar support	-\$ 57	Specify with fixed lumbar height.
Casters	• Soft, dark grey treaded, dual-wheel roll-control casters for use on hard floors	+\$ 25	Specify with soft roll-control casters.
Glides	• Glides: plastic	+\$ 25	Specify with glides.

Tip: Fire Code Seating (FCS) option is available with certain upholstery fabric choices only.
▶ Page 462

Specification Information	
Style Number	Base Price
465B300	\$1505

▶ Detailed dimensions, page 104

SIN 711.18

Think 465 Series Stool

Standard Upholstery on Back and Seat

SIN 711.18



	Standard Includes	Required to Specify
▶ Need help? Product details, page 100	<ul style="list-style-type: none"> • 10" pneumatic seat-height adjustment (22½"-32½") • Passive seat edge angle • Frame, seat shell, and five-arm base: black • 2½" seat depth adjustment • Rectilinear height-, width-, pivot-, and depth-adjustable arms • Column and adjustable foot ring: black • Adjustable lumbar • Standard upholstery design: fabric price group 1 • 2½"-diameter, hard-composition, dual-wheel casters: black 	<ol style="list-style-type: none"> 1 Style number 2 Plastic color for frame, base, and arm retainer 3 Fabric color number for upholstery on seat and back 4 Options, if selected (see below) <p>▶ See <i>Surface Materials</i>, page 432.</p>

	Options	Price	Required to Specify
Surface Materials	<p>Contrasting</p> <ul style="list-style-type: none"> • Contrasting fabrics <p>Upholstery on seat</p> <ul style="list-style-type: none"> • Fabric price group 1 • Fabric price group 2 • Fabric price group 3 • Fabric price group 4 • Fabric price group 5 • Fabric price group 6 • Fabric price group 7 • Fabric price group 8 • Fabric price group 9 • Fabric price group 10 • Steelcase leather upholstery • Select Surfaces leather price group 1 • Elmosoft leather upholstery • Select Surfaces leather price group 2 • Customer's Own Material (COM) <p>Upholstery on back</p> <ul style="list-style-type: none"> • Fabric price group 1 • Fabric price group 2 • Fabric price group 3 • Fabric price group 4 • Fabric price group 5 • Fabric price group 6 • Fabric price group 7 • Fabric price group 8 • Fabric price group 9 • Fabric price group 10 • Steelcase leather upholstery • Select Surfaces leather price group 1 • Elmosoft leather upholstery • Select Surfaces leather price group 2 • Customer's Own Material (COM) <p>Soil-retardant treatment</p> <p>Fire Code Seating (FCS)</p> <p>Frame</p> <ul style="list-style-type: none"> • Platinum • Seagull 	<p>+\$ 31</p> <p>No cost</p> <p>+\$ 10</p> <p>+\$ 24</p> <p>+\$ 33</p> <p>+\$ 42</p> <p>+\$ 51</p> <p>+\$ 58</p> <p>+\$ 76</p> <p>+\$ 93</p> <p>+\$106</p> <p>+\$163</p> <p>+\$163</p> <p>+\$191</p> <p>+\$191</p> <p>No cost</p> <p>No cost</p> <p>+\$ 14</p> <p>+\$ 26</p> <p>+\$ 35</p> <p>+\$ 43</p> <p>+\$ 53</p> <p>+\$ 62</p> <p>+\$ 77</p> <p>+\$ 94</p> <p>+\$109</p> <p>+\$171</p> <p>+\$171</p> <p>+\$197</p> <p>+\$197</p> <p>No cost</p> <p>+\$ 25</p> <p>+\$ 77</p> <p>+\$ 48</p> <p>+\$ 48</p>	<p>Specify <i>with contrasting</i>.</p> <p>Specify fabric color number.</p> <p>Specify fabric color number.</p> <p>Specify fabric color number.</p> <p>Specify fabric color number.</p> <p>Specify fabric color number.</p> <p>Specify fabric color number.</p> <p>Specify fabric color number.</p> <p>Specify fabric color number.</p> <p>Specify fabric color number.</p> <p>Specify fabric color number.</p> <p>Specify leather color number.</p> <p>▶ See <i>Surface Materials Reference Manual</i>.</p> <p>Specify Elmosoft leather color number.</p> <p>▶ See <i>Surface Materials Reference Manual</i>.</p> <p>▶ See <i>Surface Materials Reference Manual</i>.</p> <p>Specify fabric color number.</p> <p>Specify fabric color number.</p> <p>Specify fabric color number.</p> <p>Specify fabric color number.</p> <p>Specify fabric color number.</p> <p>Specify fabric color number.</p> <p>Specify fabric color number.</p> <p>Specify fabric color number.</p> <p>Specify fabric color number.</p> <p>Specify leather color number.</p> <p>▶ See <i>Surface Materials Reference Manual</i>.</p> <p>Specify Elmosoft leather color number.</p> <p>▶ See <i>Surface Materials Reference Manual</i>.</p> <p>▶ See <i>Surface Materials Reference Manual</i>.</p> <p>Specify <i>with soil-retardant treatment</i>.</p> <p>Specify <i>with fire code seating</i>.</p> <p>Specify <i>with 4799 Platinum</i>.</p> <p>Specify <i>with 7243 Seagull</i>.</p> <p>Specify <i>with height-adjustable arms</i>.</p> <p>Specify <i>with fixed arms</i>.</p> <p>Specify <i>without arms</i>.</p> <p>Specify <i>with aluminum base</i>.</p> <p>Specify <i>with fixed lumbar height</i>.</p>
	<p>Arms</p> <ul style="list-style-type: none"> • Height-adjustable arms • Fixed arms • Armless <p>Base</p> <ul style="list-style-type: none"> • Polished aluminum base <p>Lumbar</p> <ul style="list-style-type: none"> • Fixed lumbar support 	<p>-\$ 49</p> <p>-\$ 99</p> <p>-\$253</p> <p>+\$140</p> <p>-\$ 57</p>	

Tip: Fire Code Seating (FCS) option is available with certain upholstery fabric choices only.
▶ Page 462

▶ Options, continued on next page

▶ Detailed dimensions, page 104

SIN 711.18

► **Options, continued from previous page**

	Options	Price	Required to Specify
Casters	• Soft, dual-wheel roll-control casters for use on hard floors	+\$25	Specify with soft roll-control casters.
Glides	• Glides: plastic	+\$25	Specify with glides.

Specification Information

• Style	• Base
• Number	• Price
465B000	\$1447



Steelcase Series 1

Steelcase Series 1 makes high-quality seating attainable for everyone, everywhere. It delivers performance, style, and choice unprecedented in its class of seating.

Back frame and seat shell are plastic.

Lumbar height adjusts over 2¼" to provide additional lower back support.

Arm caps can pivot independently 40° inward and 40° outward to accommodate individual user preferences.

Seat height adjusts within a 5" range with a pneumatic adjustment mechanism. Short or tall range is available as an option. Stools have a 7¾" range.

Comfort dial back control provides three settings for the user's personal preference and work style.

Casters have hard, dual-wheels that roll smoothly on carpets. They are 2½" for increased mobility. Soft, dual-wheel roll-control casters are available as an option for use on hard floors or chair mats. Glides are also available as an option.
Tip: Do not roll the chair across asphalt during installation as this may damage the casters.

Arm height can adjust independently within a 5" range to help relieve upper back and shoulder fatigue.

Arm width adjusts 4" overall to support forearms in neutral position.

Arm depth can retract 2" to allow user to get closer to the worksurface and into tight corners.

Seat depth adjusts within a 2¼" range to accommodate users of varying leg lengths.

Five-arm base is available in plastic or polished aluminum.

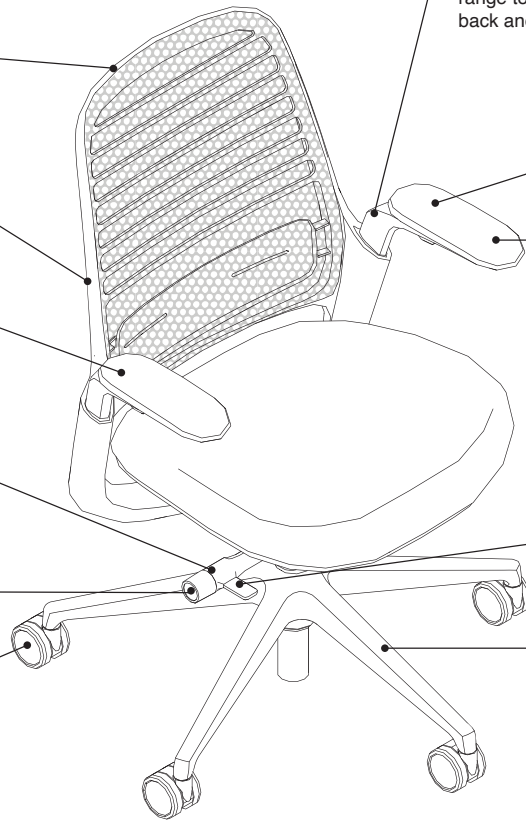

Product Details

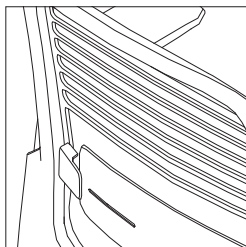

Integrated LiveBack System dynamically supports and follows the movements of the user.

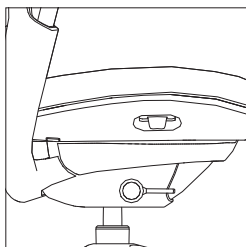

Advanced weight-activated mechanism with a natural fluid motion keeps users oriented to their work.

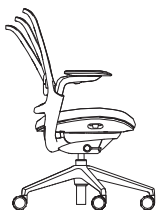

Comfort dial has three settings that allow for the user's personal preference and work style.

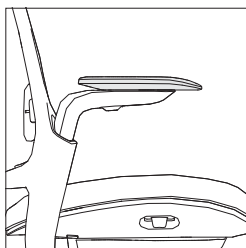

Rectilinear arms with soft caps are standard.

Uncartoned request on your dealer purchase order means Steelcase Series 1 chairs will ship fully assembled.

Cartoned request on the dealer purchase order means Steelcase Series 1 chairs will ship knocked down in seven pieces. This allows for shipment in a smaller carton. Assembly does not require tools.

Tip: Assembly instructions are included on the box.

Adjustment Features

Adjustability instructions are included with every chair.

Seat Adjustments

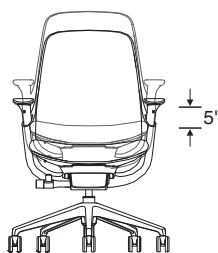

Seat height adjusts pneumatically. To lower, hold handle up while seated. To raise, hold handle up and keep your weight off the chair. Standard range of adjustability is 5" from 16½"H to 21½"H. A short ¾" range of adjustability (14¾" to 18") and a tall 4¾" range of adjustability (17¼" to 22") is available as an option. A ¾" range of adjustability (23" to 30¾") is available on stools.

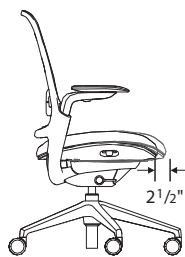

Seat depth adjusts 2½" (15½"–18") by pulling handle up. Slide seat forward or back to accommodate various leg lengths. Release handle to lock.

Back Adjustments

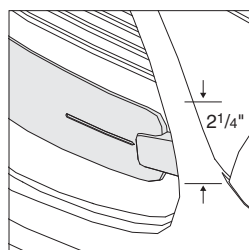

Lumbar height adjusts 2¼" (6½" to 8¾" from seat) by grabbing exposed tabs and sliding the lumbar support up or down.

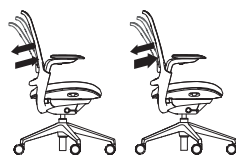

Weight-activated setting

Boosted setting



Upright setting

Comfort dial has three settings: (1) weight-activated setting; (2) boosted setting that has more resistance than your body is providing; and (3) an upright back lock setting.



Headrest accessory adjusts 3" vertically to support the head and neck of the user in both upright and recline postures. The plastic stalk and underside of the headrest will coordinate to match the frame color specified: black or seagull. The foam pad of the headrest is available in eleven 3D Microknit colors. Whether ordered initially or at a later date, the headrest ships in its own carton and must be field installed.

Arm Adjustments

Rectilinear height-, width-, pivot-, and depth-adjustable arms come standard on all arm models of chairs and stools.

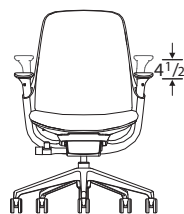

Arm height adjusts independently within a range of 4½" (6½"–11" from the seat). Push button on outside and under arm cap in while moving arms up or down. Releasing buttons locks arms in position.

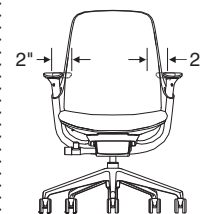

Arm width can be adjusted 2" each, 4" overall. Grasp arm cap and move in or out.

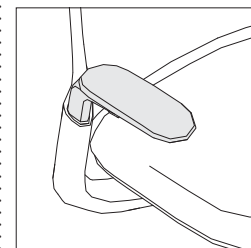

Arms pivot independently, 40° inward and outward. Grasp arm and push front to left or right.

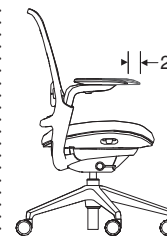

Arm depth adjusts by sliding arm caps back 2". Friction-fit mechanism keeps arms in position.

Steelcase Series 1, continued

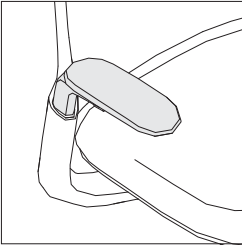
Other Features

Height-only adjustable arm is also available and adjusts 4½".



Armless models are also available.

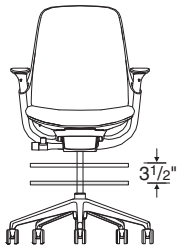

Foot ring height on stools adjusts by rotating it counterclockwise to unlock. Then raise or lower ring to desired position before rotating it clockwise to lock. The foot ring has a diameter of 20".

Soft dual-wheel roll-control casters feature an internal brake that activates when the chair is not under load to reduce shifting when user stands up.

Surface Materials

► See *Surface Materials* on page 432 for specific availability or refer to the *Surface Materials Reference Manual* for further information.

Upholstery

- Fabric
- Fabric with soil-retardant treatment (option)
- 3D Microknit (back and headrest only)
- Elmosoft leather
- Select Surfaces leather
- Leather
- Vinyl

Hard components

Back frame, stools ring, headrest, and hanger

- 6053 Seagull
- 6205 Black

Base

- 6053 Seagull
- 6205 Black
- 8046 Polished Aluminum

Pneumatic cylinders

- 6205 Black

Flexors and lumbar finishes are determined by the 3D Microknit color unless specified as contrasting.

Seat shell is determined by the frame finish.

- 6053 Seagull
- 6205 Black

Arms

- 6059 Sterling Dark (on seagull chair)
- 6205 Black (on black chair)

All Steelcase seating with standard upholstery fabrics complies with requirements of the State of California Technical Bulletin 117-2013. All standard seating is labeled to be in compliance with California 117-2013.

Programs & Services

► See *Surface Materials Reference Manual* for further detail about programs and services offered for seating.

The Customer's Own Material (COM) Program

offers the opportunity for customers to select fabrics that are not offered through the standard Steelcase surface materials program for use on Steelcase products. Through the COM program, Steelcase will test your materials for application on Steelcase products. Once approved, you can place your order. Steelcase will facilitate the entire ordering process and give you a production schedule. Steelcase will order the COM fabric directly from the textile manufacturer. For up-to-date information regarding fabric test results for all COM fabrics and details regarding yardage requirements for most seating lines, visit the COM website. To locate the COM website:

- Visit www.steelcase.com

Soil retardants are treatments that provide long-term soil and stain resistance to a fabric without affecting the shade or the integrity of the fabric. The following Steelcase Textiles are available pre-treated with soil retardant. (You do not need to select the soil-retardant option for these fabrics and incur the upcharge.)

- Jacks
- Link
- Spyder

For information on soil retardant fabrics on Select Surfaces, please refer to the *Surface Materials Reference Manual*.

Soil-retardant treatment is available on all other seating fabrics at an additional upcharge per seating unit. To order this option, please select "Soil-Retardant Treatment" under "Optional Accessories."

For soil-retardant treatment on COMs, please select "Soil-Retardant Treatment" under "Optional Accessories." Minimums or additional yardage may be required. Please contact the vendor directly for specific information.

Extended lead times may be necessary for this service.

Contact your Steelcase Solutions Fulfillment Team Representative at 1.888.STEELCASE (1.888.783.3522) or send an email to lineone@steelcase.com.

Dimensions

► Page 118

Steelcase Series 1 Upholstery

What Is It?

3D Microknit on Back only

Stitched seams are included on the seat cushion of the following:

- Leather
- Vinyl
- Upholstery
- Select Customer's Own Material/Vinyl (COM)

Tip: There are no stitching seams in Cogent:Connect.

Back

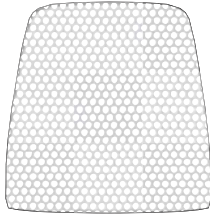

Seat

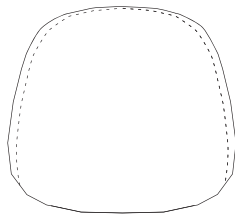

Fabric, leather, or vinyl-covered seat; 3D Microknit back only

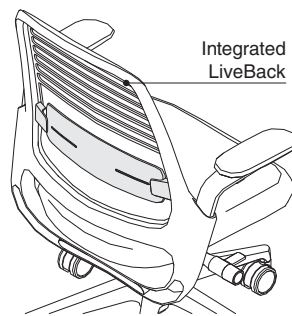

Integrated LiveBack

Back flexors are fully exposed. Lumbar and flexor colors always match. Lumbar and flexors will also match the 3D Microknit fabric unless contrasting is selected.

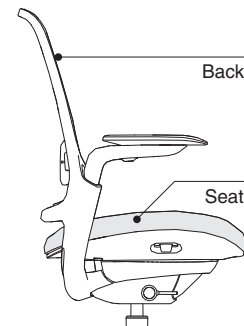

Back

Seat

Seat and back assemblies can be removed and replaced if damaged.

Dimensions

Steelcase Series 1

• Features	• Overall Depth	• Width	• Height	• Seat Depth	• Functional Seat Depth	• Seat Width	• Seat Height from Floor	• Ring Height from Floor	• Back Width	• Back Height from Seat	• Lumbar Height from Seat
------------	-----------------	---------	----------	--------------	-------------------------	--------------	--------------------------	--------------------------	--------------	-------------------------	---------------------------

Steelcase Series 1

Chair

Arms	21" to 23 ³ / ₄ "	23 ¹ / ₂ " to 27"	36 ¹ / ₂ " to 41 ¹ / ₄ "	18 ¹ / ₂ "	15 ¹ / ₂ " to 17 ³ / ₄ "	19 ¹ / ₂ "	16 ¹ / ₂ " to 21 ¹ / ₂ " (14 ³ / ₄ " to 18", 17 ¹ / ₄ " to 22" optional)	N.A.	17 ¹ / ₄ "	21 ¹ / ₂ "	6 ¹ / ₂ " to 8 ³ / ₄ "
------	---	---	--	----------------------------------	--	----------------------------------	--	------	----------------------------------	----------------------------------	--

Stool

Arms	21" to 23 ³ / ₄ "	23 ¹ / ₂ " to 27"	42 ¹ / ₄ " to 50"	18 ¹ / ₂ "	15 ¹ / ₂ " to 17 ³ / ₄ "	19 ¹ / ₂ "	23" to 30 ³ / ₄ "	11 ¹ / ₂ " to 15"	17 ¹ / ₄ "	21 ¹ / ₂ "	6 ¹ / ₂ " to 8 ³ / ₄ "
------	---	---	---	----------------------------------	--	----------------------------------	---	---	----------------------------------	----------------------------------	--

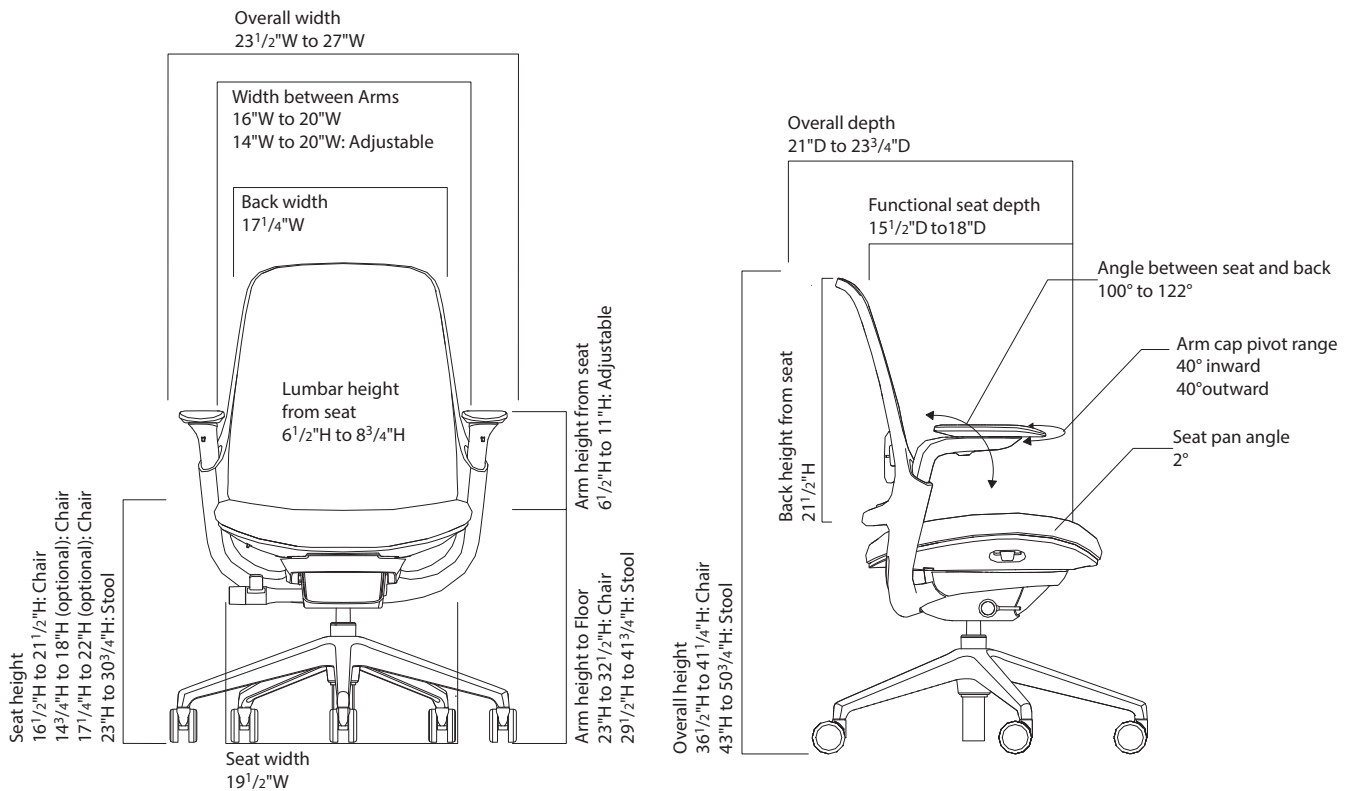

• Width • Between • Adjustable • Arms	• Width • Between • Height- • Adjustable • Arms	• Arm • to • Floor	• Arm • Height • from • Seat	• Arm Cap • Pivot • Range	• Angle • Between • Seat and • Back	• Seat • Pan • Angle	• Headrest • Height • Adjustment • Range
--	---	--------------------------	---------------------------------------	---------------------------------	--	----------------------------	---

Chair

16" to 20½"	19"	23" to 32½"	6½" to 11"	40° outward 40° inward	100° to 122°	2°	3"
-------------	-----	-------------	------------	---------------------------	--------------	----	----

Stool

16" to 20½"	19"	29½" to 41¾"	6½" to 11"	40° outward 40° inward	100° to 122°	2°	3"
-------------	-----	--------------	------------	---------------------------	--------------	----	----

Steelcase Series 1 Work Chair

3D Microknit with Standard Upholstery on Seat

SIN 711.18



Tip: When ordering seagull frame the arms are 6059 Sterling Dark Solid. When ordering black frame, arms are black.

Tip: Base finish matches frame finish, unless seagull frame is selected, then black base is also available.

Tip: Order black base on seagull frame for lowest maintenance.

► Detailed dimensions, page 118

Standard Includes		Required to Specify
► Need help? Product details, page 114	<ul style="list-style-type: none"> 5" pneumatic seat-height adjustment (16½"-21½") Frame: plastic Base: plastic 2½" seat depth adjustment Rectilinear height-, width-, pivot-, and depth-adjustable arms Adjustable lumbar Back: 3D Microknit on back Standard upholstery design on seat: fabric price group 1 2½"-diameter, hard-composition, dual-wheel casters: black only 	<ol style="list-style-type: none"> Style number Plastic color number for frame 6053 Seagull 6205 Black 3D Microknit color number for back Fabric color number for upholstery on seat Plastic color number for base: 6053 Seagull (seagull frame only) 6205 Black (black and seagull frame) Options, if selected (see below) ► See <i>Surface Materials</i>, page 432.

Options	Price	Required to Specify
Surface Materials	Upholstery on seat	
• Fabric price group 1	No cost	Specify fabric color number.
• Fabric price group 2	+\$ 10	Specify fabric color number.
• Fabric price group 3	+\$ 24	Specify fabric color number.
• Fabric price group 4	+\$ 33	Specify fabric color number.
• Fabric price group 5	+\$ 42	Specify fabric color number.
• Fabric price group 6	+\$ 51	Specify fabric color number.
• Fabric price group 7	+\$ 58	Specify fabric color number.
• Fabric price group 8	+\$ 76	Specify fabric color number.
• Fabric price group 9	+\$ 93	Specify fabric color number.
• Fabric price group 10	+\$106	Specify fabric color number.
• Steelcase leather upholstery	+\$163	Specify leather color number.
• Select Surfaces leather price group 1	+\$163	► See <i>Surface Materials Reference Manual</i> .
• Elmosoft leather upholstery	+\$191	Specify Elmosoft leather color number.
• Select Surfaces leather price group 2	+\$191	► See <i>Surface Materials Reference Manual</i> .
• Customer's Own Material (COM)	No cost	► See <i>Surface Materials Reference Manual</i> .
Soil-retardant treatment	+\$ 25	Specify with soil-retardant treatment.
Back color scheme		
• Contrasting outer back	+\$ 10	Specify with contrasting outer back.
Arms		
• Height-only adjustable	-\$ 10	Specify with height-only adjustable.
• Armless	-\$ 60	Specify without arms.
Base		
• Black	No cost	Specify with black base.
• Polished aluminum base	+\$128	Specify with aluminum base.
Lumbar		
• Adjustable lumbar	No cost	Specify with adjustable lumbar.
• Fixed lumbar	No cost	Specify with fixed lumbar.
Seat Height		
• 3¼" low-range pneumatic seat-height adjustment	+\$ 58	Specify with short-range pneumatic seat-height adjustment.
• 4¾" high-range pneumatic seat-height adjustment	+\$ 58	Specify with tall-range pneumatic seat-height adjustment.
Casters		
• Soft, dual-wheel roll-control casters for use on hard floors	+\$ 25	Specify with soft roll-control casters.
Glides		
• Plastic glides	+\$ 25	Specify with glides.

Specification Information	
Style Number	Base Price
435A00	\$640

Steelcase Series 1 Stool

3D Microknit with Standard Upholstery on Seat

SIN 711.18



Tip: When ordering seagull frame, arms are 6059 Sterling Dark Solid. When ordering black frame, arms are black.

Tip: Base finish matches frame finish, unless seagull frame is selected, then black base is also available.

Tip: Order black base on seagull frame for lowest maintenance.

Tip: Stool ring is always black for lower cleaning maintenance, even on the seagull frame.

► Detailed dimensions, page 118

Standard Includes		Required to Specify
► Need help? Product details, page 114	<ul style="list-style-type: none"> 7¾" pneumatic seat-height adjustment (23"-30¾") Frame: plastic Base: plastic 2¼" seat depth adjustment Rectilinear height-, width-, pivot-, and depth-adjustable arms Column and adjustable foot ring: black Adjustable lumbar Back: 3D Microknit Standard upholstery design on seat: fabric price group 1 2½"-diameter, hard-composition, dual-wheel casters: black only 	<ol style="list-style-type: none"> Style number Plastic color number for frame: 6053 Seagull 6205 Black 3D Microknit color number for back Fabric color number for upholstery on seat Plastic color number for base: 6053 Seagull (seagull frame only) 6205 Black (black and seagull frame) Options, if selected (see below) <p>► See <i>Surface Materials</i>, page 432.</p>

Options	Price	Required to Specify
Surface Materials		
Upholstery on seat		
• Fabric price group 1	No cost	Specify fabric color number.
• Fabric price group 2	+\$ 10	Specify fabric color number.
• Fabric price group 3	+\$ 24	Specify fabric color number.
• Fabric price group 4	+\$ 33	Specify fabric color number.
• Fabric price group 5	+\$ 42	Specify fabric color number.
• Fabric price group 6	+\$ 51	Specify fabric color number.
• Fabric price group 7	+\$ 58	Specify fabric color number.
• Fabric price group 8	+\$ 76	Specify fabric color number.
• Fabric price group 9	+\$ 93	Specify fabric color number.
• Fabric price group 10	+\$106	Specify fabric color number.
• Steelcase leather upholstery	+\$163	Specify leather color number.
• Select Surfaces leather price group 1	+\$163	► See <i>Surface Materials Reference Manual</i> .
• Elmosoft leather upholstery	+\$191	Specify Elmosoft leather color number.
• Select Surfaces leather price group 2	+\$191	► See <i>Surface Materials Reference Manual</i> .
• Customer's Own Material (COM)	No cost	► See <i>Surface Materials Reference Manual</i> .
Soil-retardant treatment	+\$ 25	Specify with soil-retardant treatment.
Back color scheme		
• Contrasting outer back	+\$ 10	Specify with contrasting outer back.
Arms		
• Height-only adjustable	-\$ 10	Specify with height-only adjustable.
• Armless	-\$ 60	Specify without arms.
Base		
• Plastic base	No cost	Specify plastic color number.
• Polished aluminum base	+\$128	Specify with aluminum base.
Lumbar		
• Adjustable lumbar	No cost	Specify with adjustable lumbar.
• Fixed lumbar	No cost	Specify with fixed lumbar.
Casters		
• Soft, dual-wheel roll-control casters for use on hard floors	+\$ 25	Specify with soft roll-control casters.
Glides		
• Plastic glides	+\$ 25	Specify with glides.

Specification Information	
Style Number	Base Price
435B00	\$820

Steelcase Series 1 Accessories

SIN 711.18

Steelcase Series 1 Headrest

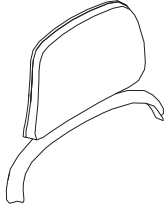

Tip: Headrest and coat hanger cannot be used together on a Steelcase Series 1 chair.

Standard Includes	Required to Specify
-------------------	---------------------

- | | | |
|--|--|--|
| ▶ Need help? Product details, page 115 | <ul style="list-style-type: none"> • Headrest frame: plastic • Headrest: 3D Microknit • 3" adjustment range | <ul style="list-style-type: none"> 1 Style number 2 Plastic color number for frame: <ul style="list-style-type: none"> 6053 Seagull 6205 Black 3 3D Microknit color number for headrest <ul style="list-style-type: none"> ▶ See <i>Surface Materials</i>, page 432. |
|--|--|--|

Specification Information	
---------------------------	--

• Style Number	• Price
435HEADREST	\$100
:	:

Steelcase Series 1 Hanger

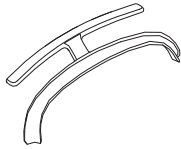

Tip: Headrest and coat hanger cannot be used together on a Steelcase Series 1 chair.

Standard Includes	Required to Specify
-------------------	---------------------

- | | |
|------------------------|---|
| • Coat hanger: plastic | <ul style="list-style-type: none"> 1 Style number 2 Plastic color number for coat hanger: <ul style="list-style-type: none"> 6053 Seagull 6205 Black |
|------------------------|---|

Specification Information	
---------------------------	--

• Style Number	• Price
435COATHANGER	\$30
:	:

Amia 482 Series

Amia is for customers seeking a timeless design that incorporates ergonomics and comfort at value price point.

Outer back and outer seat are plastic. Fully upholstered outer back is available.

LiveLumbar system offers a dialed in spring force in the lumbar region that actively supports the lower back.

Seat depth adjusts within a 3" range. Seat depth is standard on all models.

Arm height can adjust independently within a 4" range to help relieve upper back and shoulder fatigue.

Five-arm base is standard.

Casters have hard, dual wheels that roll smoothly on carpets. They are 2½" for increased mobility. Soft, dual-wheel casters are available for use on hard floors or chair mats. Stools are standard with 2" hard casters. Soft casters are available as an option.

Tip: Do not roll the chair across asphalt during installation as this may damage the casters.

Amia Air integrated LiveBack technology automatically creates flexibility and movement within the Air back.

Arm depth can be adjusted approximately 3", enabling individuals to get closer to their work.

Arm width can adjust 4½" overall to provide forearm support.

Arm caps can pivot 30° in and out to accommodate individual user preferences.

Passive seat edge angle allows the front edge of the seat to flex 1½", relieving pressure behind the thighs.

Back tension accommodates a broader range of users by allowing user to change the rate of increase, or decrease, in force as the user reclines.

Seat height adjusts within a 5" range with a pneumatic adjustment mechanism. Stools have an 8" range.

Upright back lock allows the user to lock the back in a full upright position, or release it for full-tilt motion.

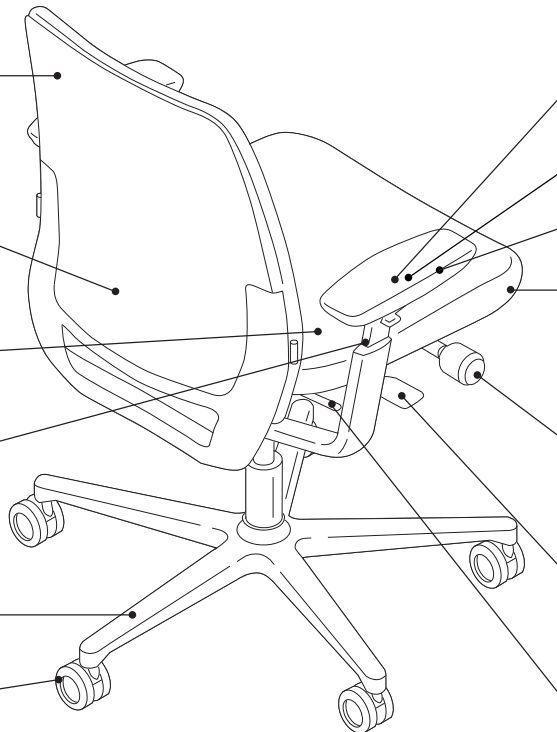

Product Details

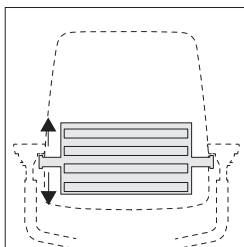

LiveLumbar system

allows the user to experience continuous back support with dialed in spring force that can be adjusted to match the users anatomy. Available on standard Amia chairs.

Integrated LiveBack

automatically creates flexibility and movement in the Air back to ensure dynamic back support as you recline. A height adjustable lumbar is also available on the Amia Air with 3D Microknit.



Rectilinear arms with soft caps

are standard with adjustable seats that include seat depth and passive seat edge angle.

Adjustability instructions are included with every chair. Instructions can also be found at www.steelcase.com

Cartoned request on your dealer purchase order means Amia chairs will ship knocked down with the chair back separated from the rest of the chair. This allows for shipment in a smaller carton. Assembly by a qualified dealer installer is required. Assembly instructions are included. This does not apply to Amia stools.

Uncartoned request on your dealer purchase order means Amia chairs will ship fully assembled.

Adjustment Features

Seat Adjustments

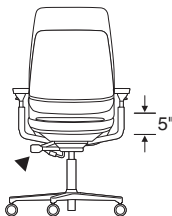

Seat height adjusts pneumatically. To lower, hold handle up while seated. To raise, hold handle up and keep your weight off the chair. Range of adjustability is 5", from 16"H to 21"H, and is standard on work chairs. A lower range of adjustability (15"H to 19"H) is available as an option. A higher range of adjustability (17"H to 24"H) is available as an option. An 8" range of adjustability (23"H to 31"H) is available on stools.

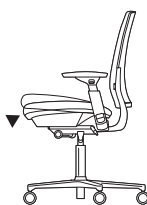

Passive seat edge angle flexes, relieving pressure under the user's thighs. The front flexes 1½". This feature is standard on all work chairs and stools.

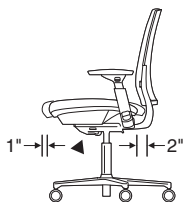

Seat depth adjusts 3" (15½"-18½") by pulling handle up. Slide seat forward or back to accommodate various leg lengths. Release handle to lock. This feature is standard on work chairs and stools.

Back Adjustments

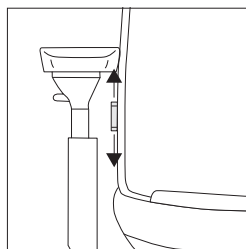

Lumbar height adjusts 3¾" (6¼" to 10" from seat) by grabbing exposed tabs and sliding the lumbar support up or down. This feature is standard on work chairs and stools.

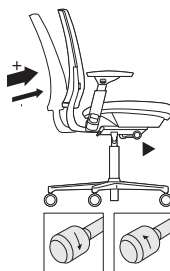

Back tension adjusts by turning knob forward to increase back tension, backward to decrease back tension. This feature is standard on work chairs and stools.

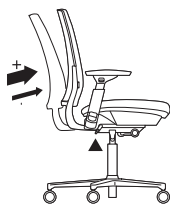

Upright back lock. To release, lean forward and pull toward back. To lock, lean forward and push toward front.

Arm Adjustments

Rectilinear height-, width-, pivot-, and depth-adjustable arms come standard on all arm models of chairs and stools.

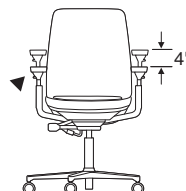

Arm height adjusts independently within a range of 4" (7"-11" from the seat). Push button on outside and under arm cap in while moving arms up or down. Releasing buttons locks arms in position.

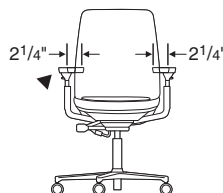

Arm width adjusts 2¼" each independently on chairs with this option. Grasp arm and move in or out.

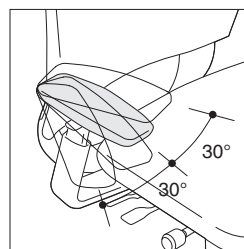

Arms pivot independently 30° inward and outward. Grasp arm and push front to left or right.

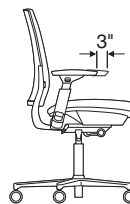

Arm depth adjusts approximately 3" to enable user to get closer to worksurface.

Other Features

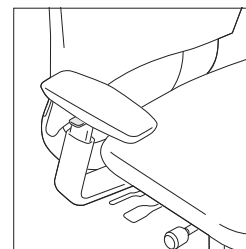

Height-only adjustable arm is also available and adjusts 4".



Armless models are also available.

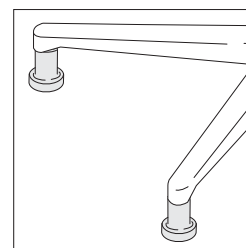

Glides are available as an option. Glides ship with chair or stool for field installation and maintain same height as casters.

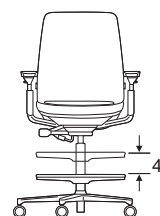

Foot ring height on stools adjusts by first lifting ring and rotating it counter-clockwise to unlock. Then raise or lower ring up to 4" to desired position before rotating it clockwise to lock. The foot ring has a diameter of 20".

Soft-wheel casters for hard floors are available for specific applications.

Amia 482 Series, continued

Surface Materials

► See surface materials on page 432 for specific availability or refer to the *Surface Materials Reference Manual* for further information.

Upholstery

- Fabric
- Fabric with soil-retardant treatment (option)
- 3D Knit (back only)
- 3D Microknit (Amia back only)
- Leather
- Elmosoft leather
- Select Surfaces leather
- Customer's Own Leather (COL)
- Select Customer's Own Material/Vinyl (COM)

Hard components

- Back frame, outer back, arm retainer, and base
- 4799 Platinum Metallic
 - 6053 Seagull
 - 6205 Black
 - 7250 Sterling Dark

Air back

- 5U22 Royal Blue
- 5U23 Blue Jay
- 5U24 Scarlet
- 5U25 Malt
- 5U26 Wasabi
- 5U27 Concord
- 5U28 Canary
- 6053 Seagull
- 6205 Black
- 6249 Platinum Solid
- 6295 Near Black
- 6332 Citron
- 6BD1 Aubergine
- 6BD2 Peacock
- 6BD3 Jungle
- 6BD4 Merlot
- 6BD5 Honey
- 6BD6 Lagoon
- 6BD7 Saffron

Outer back

- Fully upholstered

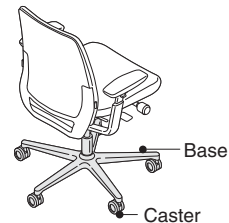
**Polished aluminum base and casters**

are available on chairs only. Polished aluminum casters approved to 225 pounds only. Stools are not available with this base.

Arm caps

- Black
- Leather

Column and foot ring on stools

- 7207 Black only

All Steelcase seating with standard upholstery fabrics

complies with requirements of the State of California Technical Bulletin 117-2013. All standard seating is labeled to be in compliance with California 117-2013.

Programs & Services

► See the *Surface Materials Reference Manual* for further detail about programs and services offered for seating.

The Customer's Own Material (COM) Program

offers the opportunity for customers to select fabrics that are not offered through the standard Steelcase surface materials program for use on Steelcase products. Through the COM program, Steelcase will test your materials for application on Steelcase products. Once approved, you can place your order. Steelcase will facilitate the entire ordering process and give you a production schedule. Steelcase will order the COM fabric directly from the textile manufacturer.

For up-to-date information regarding fabric test results for all COM fabrics and details regarding yardage requirements for most Seating lines, visit the COM website. To locate the COM website:

- Visit www.steelcase.com

Soil retardants are treatments that provide long-term soil and stain resistance to a fabric without affecting the shade or the integrity of the fabric. The following Steelcase Textiles are available pre-treated with soil retardant. (You do not need to select the soil-retardant option for these fabrics and incur the upcharge.)

- Jacks
- Link
- Spyder

For information on soil retardant fabrics on Select Surfaces, please refer to the *Surface Materials Reference Manual*.

Soil-retardant treatment is available on all other seating fabrics at an additional upcharge per seating unit. To order this option, please select "Soil-Retardant Treatment" under "Optional Accessories."

For soil-retardant treatment on COMs, please select "Soil-Retardant Treatment" under "Optional Accessories." Minimums or additional yardage may be required. Please contact the vendor directly for specific information.

Soil-retardant treatment is available on all other seating fabrics at an additional upcharge per seating unit. To order this option, please select "Soil-Retardant Treatment" under "Optional Accessories."

For soil-retardant treatment on COMs, please select "Soil-Retardant Treatment" under "Optional Accessories." Minimums or additional yardage may be required. Please contact the vendor directly for specific information.

Extended lead times may be necessary for this service.

Contact your Steelcase Solutions Fulfillment Team Representative at 1.888.STEELCASE (1.888.783.3522) or send an email to lineone@steelcase.com.

Fire Codes

► See pages 462 for upholstery fabrics available for use with FCS modification.

Steelcase offers Fire Code Seating modification (FCS) on some seating models. The most rigorous fire codes in the nation have been developed in California, and the Steelcase FCS modification is designed to meet those codes. Fire Code Seating (FCS) indicates that a product is constructed to meet the strict fire code requirements of high public occupancy areas such as theaters, meeting rooms, and lobbies. The FCS standards will meet the State of California Bureau of Electronic and Appliance Repair, Home Furnishings, and Thermal Insulation Technical Bulletin 133 (Cal TB 133). Boston adopted the California Bureau of Electronic and Appliance Repair, Home Furnishings, and Thermal Insulation Technical Bulletin TB 133 test standard in 1992.

Local codes may have special requirements for upholstery.

Dimensions

► Page 128

Resources**Printed Materials**

- Amia Brochure (11-0002073)
- Amia User Guide (07-0006468)
- Amia LiveLumbar card (08-0000111)
- Innovation Seating Brochure (04-0011870)
- Alive Seating Story
- Amia Air Cut Sheet (18-0005529)

Online Resources

- Interactive User Guide available on www.steelcase.com
- Amia Model Sales Presentation DVD
- Amia Design Story video available on www.steelcase.com
- Adjustability video available on www.steelcase.com
- Environmental profiles available on www.steelcase.com/sustainability

Amia Upholstery

What Is It?

Fabric, leather, or vinyl-covered back and seat, 3D Knit back.

Fabric

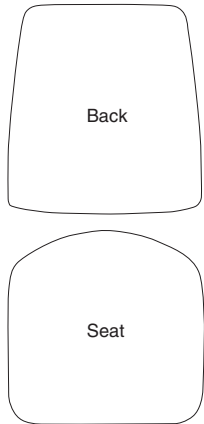

Leather, Vinyl, and Select Fabrics

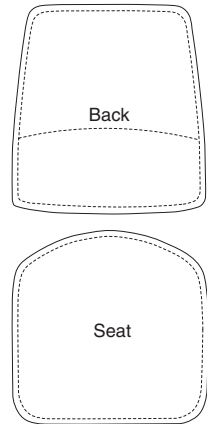

3D Knit Back and Microknit Back

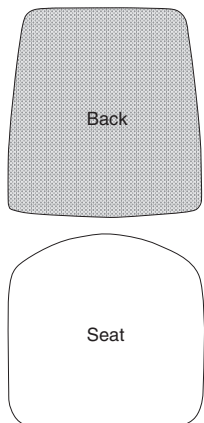

Stitched seams are included on the back cushion and seat cushion of the following:

- Leather
- Select Surfaces leather
- Elmosoft leather
- Customer's Own Leather (COL)
- Vinyl
- Select Customer's Own Material/Vinyl (COM)
- Select Fabrics

Pattern alignment at the lumbar seam cannot be guaranteed.

3D Knit back is made up of three layers: the 3D Knit, a solid fabric that matches the 3D Knit color, and the polyester cushion that provides exceptional comfort. The seat on these models can be specified to match the 3D Knit color or in any other material.

3D Microknit back is available on the Amia Air back version only. A Cogent: Connect fabric can be specified on the seat to color match the 3D Microknit (exception: Seagull). The 3D Microknit can be specified to match or contrast the Amia Air back.

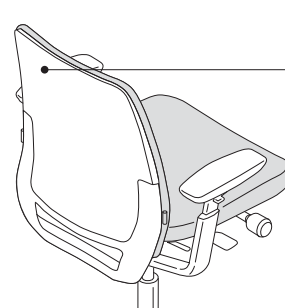

Plastic outer back is fully exposed. Fully upholstered outer back is available.

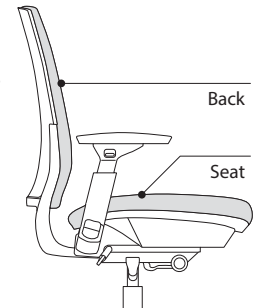

Seat and back cushions can be removed and replaced if damaged.

Dimensions

Amia 482 Series

Features	Overall Depth	Width	Height	Seat Depth	Functional Seat Depth	Seat Width	Seat Height from Floor	Ring Height from Floor	Back Width	Back Height from Seat
Amia 482 Series										
Work Chairs										
Adjustable Seat Depth	21 ³ / ₄ " to 24 ³ / ₄ "	26 ⁵ / ₈ "	37 ¹ / ₄ " to 42 ¹ / ₂ "	18 ¹ / ₂ "	15 ¹ / ₂ " to 18 ¹ / ₂ "	19 ³ / ₈ "	16" to 21"	N.A.	18 ⁷ / ₈ "	25"
Stools										
Adjustable Seat Depth	21 ³ / ₄ " to 24 ³ / ₄ "	26 ⁵ / ₈ "	44 ¹ / ₄ " to 52 ¹ / ₂ "	18 ¹ / ₂ "	15 ¹ / ₂ " to 18 ¹ / ₂ "	19 ³ / ₈ "	23" to 31"	10 ¹ / ₄ " to 14 ¹ / ₄ "	18 ⁷ / ₈ "	25"

Dimensions were measured with BIFMA CMD (chair-measuring device).

Arm width adjustment is 15"–19¹/₂". Arm pivot adjustment adds 2³/₄" to the width providing a total of 12¹/₄"–20¹/₂" of width between the arms.

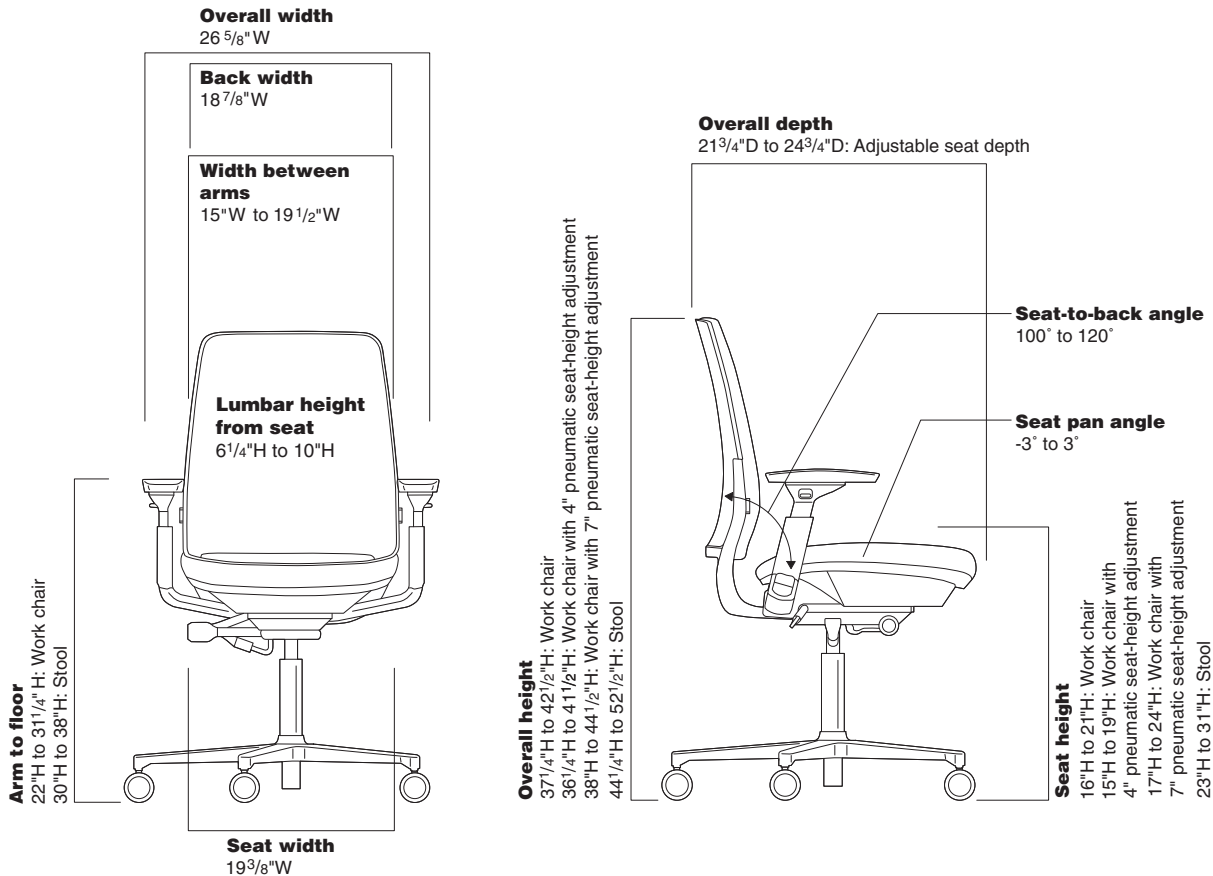

• Back Lumbar Height	• Lumbar Flex Zone	• Width Between Arms	• Arm to Floor	• Arm Height from Seat	• Arm Cap Pivot Range	• Seat Pan Angle	• Angle Between Seat and Back
----------------------	--------------------	----------------------	----------------	------------------------	-----------------------	------------------	-------------------------------

Work Chairs

6¼" to 10"	5¼" to 10¼"	15" to 19½"	22" to 32¼"	7" to 11"	30°	-3° to 3°	100° to 120°
------------	-------------	-------------	-------------	-----------	-----	-----------	--------------

Stools

6¼" to 10"	5¼" to 10¼"	15" to 19½"	30" to 38"	7" to 11"	30°	-3° to 3°	100° to 120°
:	:	:	:	:	:	:	:

Amia 482 Series Work Chair

Sewn Leather Upholstery on Back, Seat, and Arm Caps

SIN 711.18



Standard Includes	Required to Specify
<p>► Need help? Product details, page 124</p> <ul style="list-style-type: none"> • Synchro-tilt mechanism • 5" pneumatic seat-height adjustment • Upright back lock • Rectilinear independent height-, width-, pivot-, and depth-adjustable arms • Frame and arms: platinum • 3" seat depth adjustment • Five-arm base: polished aluminum • Passive seat edge angle • Adjustable lumbar • Fully upholstered outer back, seat, and arm caps: leather • Sewn upholstery design • 2½"-diameter, hard-composition, dual-wheel casters: polished aluminum 	<ul style="list-style-type: none"> 1 Style number 2 Leather color number for upholstery on back, seat, and arm caps 3 Options, if selected (see below) <p>► See <i>Surface Materials</i>, page 432.</p>

Tip: Always add suffixes in alphabetical order when specifying options to Amia seating.

Tip: Fire Code Seating (FCS) option is available with certain upholstery fabric choices only.

► Page 462

Tip: Fire Code Seating (FCS) option is available on Amia chairs with fully adjustable arms only.

Tip: Plastic base available with plastic casters only.

Tip: Polished aluminum casters are available on a polished aluminum base only.

Options	Price	Required to Specify
<p>Surface Materials</p> <p>Upholstery</p> <ul style="list-style-type: none"> • Elmosoft leather upholstery +\$ 83 • Select Surfaces leather price group 2 +\$ 83 • Customer's Own Leather (COL) No cost <hr/> <p>Fire Code Seating (FCS) +\$ 77</p> <hr/> <p>Soil-retardant treatment +\$ 25</p> <hr/> <p>Frame and arms</p> <ul style="list-style-type: none"> • Black plastic -\$ 86 		<p>Specify Elmosoft leather color number.</p> <p>► See <i>Surface Materials Reference Manual</i>. Specify leather color number.</p> <hr/> <p>Add suffix F to the style number.</p> <hr/> <p>Specify with <i>soil-retardant treatment</i>.</p> <hr/> <p>Specify with <i>6205 Black</i>.</p>
<p>Base</p> <ul style="list-style-type: none"> • Plastic base -\$208 		Specify with <i>plastic base</i> .
<p>Arms</p> <ul style="list-style-type: none"> • Height-adjustable arms, soft arm caps -\$ 88 		Specify with <i>height-adjustable arms</i> .
<p>Seat Height</p> <ul style="list-style-type: none"> • 4" pneumatic seat-height adjustment +\$ 58 • 7" pneumatic seat-height adjustment +\$ 58 		Specify with <i>4" pneumatic seat-height adjustment</i> . Specify with <i>7" pneumatic seat-height adjustment</i> .
<p>Casters</p> <p>Polished aluminum base</p> <ul style="list-style-type: none"> • Soft, dual-wheel casters for use on hard floors: polished aluminum +\$ 25 • Hard, dual-wheel casters for use on soft floors: plastic -\$ 59 • Soft, dark grey treaded, dual-wheel roll-control casters for use on hard floors: plastic -\$ 36 <hr/> <p>Plastic base</p> <ul style="list-style-type: none"> • Soft, dark grey treaded, dual-wheel roll-control casters for use on hard floors: plastic +\$ 25 		Specify with <i>soft polished aluminum casters</i> . Specify with <i>hard plastic casters</i> . Specify with <i>soft roll-control casters</i> . Specify with <i>soft roll-control casters</i> .
<p>Glides</p> <p>Polished aluminum base</p> <ul style="list-style-type: none"> • Glides: plastic -\$ 36 <hr/> <p>Plastic base</p> <ul style="list-style-type: none"> • Glides: plastic +\$ 25 		Specify with <i>glides</i> . Specify with <i>glides</i> .

Specification Information

Style Number	Base Price
4821410LS	\$2131

► Detailed dimensions, page 128

Seating

Amia 482 Series
Work Chair

SIN 711.18

Amia 482 Series

Amia 482 Series Work Chair

Upholstery on Back and Seat

SIN 711.18



Tip: Frame packages include outer back shell, outer back frame, arm holsters, outer seat shell, and base.

Tip: Leather and vinyl upcharges are in addition to sewn upholstery upcharge.

Tip: Suffixes other than **K** for contrasting fabric, will be added in alphabetical order when specifying options. The contrasting fabric suffix, **K**, will always be at the end of the style number.

► Detailed dimensions, Page 128

Standard Includes		Required to Specify
► Need help? Product details, page 124	<ul style="list-style-type: none"> • Synchro-tilt mechanism • 5" pneumatic seat-height adjustment • Upright back lock • Rectilinear independent height-, width-, pivot-, and depth-adjustable arms and soft arm caps: black plastic • Frame, seat shell, outer back, and five-arm base: plastic • 3" seat depth adjustment • Passive seat edge angle • Adjustable lumbar • Standard upholstery design: fabric price group 1 • 2½"-diameter, hard-composition, dual-wheel casters: black 	<ol style="list-style-type: none"> 1 Style number 2 Frame package color scheme (see below under Required Selections) 3 Fabric color number for upholstery on seat and back 4 Options, if selected (see below) <p>► See <i>Surface Materials</i>, page 432.</p>

Required Selections	Price	Required to Specify
Frame Package Color Scheme		
• Black	No cost	Specify with 6205 Black.
• Merle	+\$ 48	Specify with 6527 Merle.
• Platinum	+\$ 48	Specify with 6249 Platinum.
• Seagull	+\$ 40	Specify with 6053 Seagull.

Options	Price	Required to Specify
Surface Materials		
Upholstery on seat and back		
• Fabric price group 1	No cost	Specify fabric color number.
• Fabric price group 2	+\$ 26	Specify fabric color number.
• Fabric price group 3	+\$ 48	Specify fabric color number.
• Fabric price group 4	+\$ 68	Specify fabric color number.
• Fabric price group 5	+\$ 85	Specify fabric color number.
• Fabric price group 6	+\$106	Specify fabric color number.
• Fabric price group 7	+\$121	Specify fabric color number.
• Fabric price group 8	+\$153	Specify fabric color number.
• Fabric price group 9	+\$188	Specify fabric color number.
• Fabric price group 10	+\$213	Specify fabric color number.
• Steelcase leather upholstery	+\$283	Add suffix S to the style number and specify leather color number.
• Select Surfaces leather price group 1	+\$283	Add suffix S to the style number and specify Select Surfaces leather price group 1.
		► See <i>Surface Materials Reference Manual</i> .
• Elmosoft leather upholstery	+\$337	Add suffix S to the style number and specify Elmosoft leather color number.
• Select Surfaces leather price group 2	+\$337	Add suffix S to the style number and specify Select Surfaces leather price group 2.
		► See <i>Surface Materials Reference Manual</i> .
• Steelcase vinyl	+\$ 26	Add suffix S to the style number and specify vinyl color number.
		► See <i>Surface Materials Reference Manual</i> to specify.
• Customer's Own Material (COM)	No cost	Add suffix S to the style number and specify leather color number.
• Customer's Own Leather (COL)	No cost	
Sewn upholstery		
• Sewn upholstery on chair	+\$ 77	Add suffix S to the style number.
Contrasting upholstery on seat and back		
• Contrasting fabrics	+\$ 31	Add suffix K to the style number and specify fabric color numbers.

► Options, continued on next page

► Options, continued from previous page

Options	Price	Required to Specify
Surface Materials, continued		
Contrasting upholstery on seat		
• Fabric price group 1	No cost	Specify fabric color number.
• Fabric price group 2	+\$ 10	Specify fabric color number.
• Fabric price group 3	+\$ 26	Specify fabric color number.
• Fabric price group 4	+\$ 35	Specify fabric color number.
• Fabric price group 5	+\$ 42	Specify fabric color number.
• Fabric price group 6	+\$ 51	Specify fabric color number.
• Fabric price group 7	+\$ 62	Specify fabric color number.
• Fabric price group 8	+\$ 77	Specify fabric color number.
• Fabric price group 9	+\$ 94	Specify fabric color number.
• Fabric price group 10	+\$109	Specify fabric color number.
• Steelcase leather upholstery	+\$141	Add suffix S to the style number and specify leather color number.
• Select Surfaces leather price group 1	+\$141	Add suffix S to the style number and specify leather color number.
• Elmosoft leather upholstery	+\$168	Add suffix S to the style number and specify leather color number.
• Select Surfaces leather price group 2	+\$168	Add suffix S to the style number and specify leather color number.
• Customer's Own Material (COM)	No cost	► See <i>Surface Materials Reference Manual</i>
Contrasting upholstery on back		
• Fabric price group 1	No cost	Specify fabric color number.
• Fabric price group 2	+\$ 16	Specify fabric color number.
• Fabric price group 3	+\$ 22	Specify fabric color number.
• Fabric price group 4	+\$ 33	Specify fabric color number.
• Fabric price group 5	+\$ 43	Specify fabric color number.
• Fabric price group 6	+\$ 55	Specify fabric color number.
• Fabric price group 7	+\$ 59	Specify fabric color number.
• Fabric price group 8	+\$ 76	Specify fabric color number.
• Fabric price group 9	+\$ 94	Specify fabric color number.
• Fabric price group 10	+\$104	Specify fabric color number.
• Steelcase leather upholstery	+\$142	Add suffix S to the style number and specify leather color number.
• Select Surfaces leather price group 1	+\$142	Add suffix S to the style number and specify leather color number.
• Elmosoft leather upholstery	+\$169	Add suffix S to the style number and specify leather color number.
• Select Surfaces leather price group 2	+\$169	Add suffix S to the style number and specify leather color number.
• Customer's Own Material (COM)	No cost	► See <i>Surface Materials Reference Manual</i>
Soil-retardant treatment	+\$ 25	Specify with soil-retardant treatment.
Fire Code Seating (FCS)	+\$ 77	Add suffix F to the style number.
Fully upholstered		
• Fully upholstered with fabric	+\$129	Add suffix U to the style number.
• Fully upholstered with leather	+\$206	Add suffix SU to the style number.
• Steelcase leather fully upholstered outer back	+\$462	Add suffix SU to the style number and specify leather color number.
• Select Surfaces leather price group 1 fully upholstered outer back	+\$462	Add suffix SU to the style number and specify Select Surfaces leather price group 1.
		► See <i>Surface Materials Reference Manual</i>
• Elmosoft leather fully upholstered outer back	+\$544	Add suffix SU to the style number and specify Elmosoft leather color number.
• Select Surfaces leather price group 2	+\$544	Add suffix SU to the style number and specify Select Surfaces leather price group 2.
		► See <i>Surface Materials Reference Manual</i>
• Customer's Own Leather (COL) fully upholstered outer back	No cost	Add suffix SU to the style number.
		► See <i>Surface Materials Reference Manual</i> to specify.

Tip: Leather and vinyl upcharges are in addition to sewn upholstery upcharge.

Tip: Fire Code Seating (FCS) option is available with certain upholstery fabric choices only.

► Page 462

Tip: To get leather on a fully upholstered chair, you will need to add both the fully upholstered with leather upcharge and the upcharge for the leather itself.

► Options, continued on next page

Amia 482 Series Work Chair, Upholstery on Back and Seat, continued

SIN 711.18

► Options, continued from previous page

	Options	Price	Required to Specify
Base	<ul style="list-style-type: none"> Polished aluminum base 	+\$149	Specify with polished aluminum base.
Arms	<ul style="list-style-type: none"> Height-adjustable arms, soft arm cap Armless 	-\$ 88 -\$207	Specify with height-adjustable arms. Specify without arms.
Seat Height	<ul style="list-style-type: none"> 4" pneumatic seat-height adjustment 7" pneumatic seat-height adjustment 	+\$ 58 +\$ 58	Specify with 4" pneumatic seat-height adjustment. Specify with 7" pneumatic seat-height adjustment.
Casters	<ul style="list-style-type: none"> Soft, dark grey treaded, dual-wheel roll-control casters for use on hard floors Hard, polished aluminum casters on polished aluminum base for use on soft floor Soft, polished aluminum casters on polished aluminum base for use on hard floors 	+\$ 25 +\$ 59 +\$ 83	Specify with soft roll-control casters. Specify with hard polished aluminum casters. Specify with soft polished aluminum casters.
Glides	<ul style="list-style-type: none"> Glides: plastic 	+\$ 25	Specify with glides.

Specification Information

Style Number	Base Price
4821410	\$1039



Seating

Amia 482 Series
Work Chair

SIN 711.18

Amia 482 Series

Amia 482 Series Work Chair

3D Knit on Back with Upholstery on Seat

SIN 711.18



Tip: Frame packages include outer back shell, outer back frame, arm holsters, outer seat shell, and base.

Tip: Leather and vinyl upcharges are in addition to sewn upholstery upcharge.

Tip: Fire Code Seating (FCS) option is available with certain upholstery fabric choices only.

▶ Page 462

Tip: Fire Code Seating (FCS) option is available on Amia chairs with fully adjustable arms or armless models only.

▶ Detailed dimensions, Page 128

Standard Includes		Required to Specify
▶ Need help? Product details, page 124	<ul style="list-style-type: none"> • Synchro-tilt mechanism • 5" pneumatic seat-height adjustment • Upright back lock • Rectilinear independent height-, width-, pivot-, and depth-adjustable arms and soft arm caps: black plastic • Frame, seat shell, outer back, and five-arm base: plastic • 3" seat depth adjustment • Passive seat edge angle • Adjustable lumbar • 3D Knit on back only • Standard upholstery design on seat: fabric price group 1 • 2½"-diameter, hard-composition, dual-wheel casters: black 	<ol style="list-style-type: none"> 1 Style number 2 Frame package color scheme (see below under Required Selections) 3 3D Knit color for back 4 Fabric color number for upholstery on seat 5 Options, if selected (see below) <p>▶ See <i>Surface Materials</i>, page 432.</p>

Required Selections	Price	Required to Specify
Frame Package Color Scheme		
• Black	No cost	Specify with 6205 Black.
• Merle	+\$ 48	Specify with 6527 Merle.
• Platinum	+\$ 48	Specify with 6249 Platinum.
• Seagull	+\$ 40	Specify with 6053 Seagull.

Options	Price	Required to Specify
Surface Materials		
Upholstery		
• Fabric price group 1	No cost	Specify fabric color number.
• Fabric price group 2	+\$ 10	Specify fabric color number.
• Fabric price group 3	+\$ 26	Specify fabric color number.
• Fabric price group 4	+\$ 35	Specify fabric color number.
• Fabric price group 5	+\$ 42	Specify fabric color number.
• Fabric price group 6	+\$ 51	Specify fabric color number.
• Fabric price group 7	+\$ 62	Specify fabric color number.
• Fabric price group 8	+\$ 77	Specify fabric color number.
• Fabric price group 9	+\$ 94	Specify fabric color number.
• Fabric price group 10	+\$109	Specify fabric color number.
• Steelcase leather upholstery	+\$142	Specify fabric color number.
• Select Surfaces leather price group 1	+\$142	Add suffix S to the style number and specify leather color number.
• Elmosoft leather upholstery	+\$169	Add suffix S to the style number and specify Select Surfaces leather price group 1.
• Select Surfaces leather price group 2	+\$169	▶ See <i>Surface Materials Reference Manual</i> . Add suffix S to the style number and specify Elmosoft leather color number.
• Steelcase vinyl	+\$ 10	Add suffix S to the style number and specify Select Surfaces leather price group 2.
• Customer's Own Material (COM)	No cost	▶ See <i>Surface Materials Reference Manual</i> . Add suffix S to the style number and specify vinyl color number.
• Customer's Own Leather (COL)	No cost	▶ See <i>Surface Materials Reference Manual</i> to specify. Add suffix S to the style number and specify leather color number.

Fire Code Seating (FCS)	+\$ 77	Add suffix F to the style number.
Soil-retardant treatment	+\$ 25	Specify with soil-retardant treatment.
Sewn upholstery		
• Sewn upholstery on chair	+\$ 41	Add suffix S to the style number.
Base		
• Polished aluminum base	+\$149	Specify with polished aluminum base.

▶ Options, continued on next page

► Options, continued from previous page

Options	Price	Required to Specify	
Arms	• Height-adjustable arms, soft arm caps	–\$ 88	Specify with height-adjustable arms.
	• Armless	–\$207	Specify without arms.
Seat Height	• 4" pneumatic seat-height adjustment	+\$ 58	Specify with 4" pneumatic seat-height adjustment.
	• 7" pneumatic seat-height adjustment	+\$ 58	Specify with 7" pneumatic seat-height adjustment.
Casters	• Soft, dark grey treaded, dual-wheel roll-control casters for use on hard floors	+\$ 25	Specify with soft roll-control casters.
	• Hard, polished aluminum casters on polished aluminum base for use on soft floors	+\$ 59	Specify with hard polished aluminum casters.
	• Soft, polished aluminum casters on polished aluminum base for use on hard floors	+\$ 83	Specify with soft polished aluminum casters.
Glides	• Glides: plastic	+\$ 25	Specify with glides.

Specification Information

Style Number	Base Price
4821418	\$1098



Amia 482 Series Work Chair

Air Back with Upholstery on Seat

SIN 711.18



Standard Includes		Required to Specify
<ul style="list-style-type: none"> ▶ Need help? Product details, page 124 	<ul style="list-style-type: none"> • Frame package • Synchro-tilt mechanism • 5" pneumatic seat-height adjustment • Upright back lock • Rectilinear independent height-, width-, pivot-, and depth-adjustable arms and soft arm caps: black plastic • 3" seat depth adjustment • Passive seat edge angle • Air back with integrated LiveBack technology: plastic • Standard upholstery design on seat: fabric price group 1 • 2½"-diameter, hard-composition, dual-wheel casters: black 	<ol style="list-style-type: none"> 1 Style number 2 Frame package color scheme (see below under Required Selections) 3 Fabric color number for upholstery on seat 4 Air back plastic color number 5 Options, if selected (see below) <p>▶ See <i>Surface Materials</i>, page 432.</p>

Tip: Amia Air frame packages include inner back frame and lumbar, outer back frame, arm holsters, outer seat shell, and base.

Tip: When merle, platinum, or seagull are selected as frame packages, the outer seat shell and inner back frame default to 6527 Merle plastic.

Tip: Always add suffixes in alphabetical order when specifying options to Amia seating.

Tip: Leather and vinyl upcharges are in addition to sewn upholstery upcharge.

Required Selections	Price	Required to Specify
Frame Package	• Black • Merle	No cost +\$ 48
Color Scheme	• Platinum • Seagull	+\$ 48 +\$ 40
		Specify with 6205 Black. Specify with 6527 Merle. Specify with 6249 Platinum. Specify with 6053 Seagull.

Options	Price	Required to Specify
Surface Materials		
Upholstery		
• Fabric price group 1	No cost	Specify fabric color number.
• Fabric price group 2	+\$ 10	Specify fabric color number.
• Fabric price group 3	+\$ 26	Specify fabric color number.
• Fabric price group 4	+\$ 35	Specify fabric color number.
• Fabric price group 5	+\$ 42	Specify fabric color number.
• Fabric price group 6	+\$ 51	Specify fabric color number.
• Fabric price group 7	+\$ 62	Specify fabric color number.
• Fabric price group 8	+\$ 77	Specify fabric color number.
• Fabric price group 9	+\$ 94	Specify fabric color number.
• Fabric price group 10	+\$109	Specify fabric color number.
• Steelcase leather upholstery	+\$142	Specify fabric color number.
• Select Surfaces leather price group 1	+\$142	Add suffix S to the style number and specify leather color number. Add suffix S to the style number and specify Select Surfaces leather price group 1.
• Elmosoft leather upholstery	+\$169	▶ See <i>Surface Materials Reference Manual</i> . Add suffix S to the style number and specify Elmosoft leather color number.
• Select Surfaces leather price group 2	+\$169	Add suffix S to the style number and specify Select Surfaces leather price group 2.
• Steelcase vinyl	+\$ 10	▶ See <i>Surface Materials Reference Manual</i> . Add suffix S to the style number and specify vinyl color number.
• Customer's Own Material (COM)	No cost	▶ See <i>Surface Materials Reference Manual</i> to specify.
• Customer's Own Leather (COL)	No cost	Add suffix S to the style number and specify leather color number.
Soil-retardant treatment	+\$ 25	Specify with soil-retardant treatment.
Sewn upholstery		
• Sewn upholstery on chair	+\$ 41	Add suffix S to the style number.
Base	• Polished aluminum base	+\$149 Specify with polished aluminum base.
Arms	• Height-adjustable arms, soft arm caps • Armless	-\$ 88 -\$207 Specify with height-adjustable arms. Specify without arms.

▶ Options, continued on next page

▶ Detailed dimensions, Page 128

► Options, continued from previous page

Options	Price	Required to Specify	
Seat Height	• 4" pneumatic seat-height adjustment	+\$58	Specify with 4" pneumatic seat-height adjustment.
	• 7" pneumatic seat-height adjustment	+\$58	Specify with 7" pneumatic seat-height adjustment.
Casters	• Soft, dark grey treaded, dual-wheel roll-control casters for use on hard floors	+\$25	Specify with soft roll-control casters.
	• Hard, polished aluminum casters on polished aluminum base for use on soft floors	+\$59	Specify with hard polished aluminum casters.
	• Soft, polished aluminum casters on polished aluminum base for use on hard floors	+\$83	Specify with soft polished aluminum casters.
Glides	• Glides: plastic	+\$25	Specify with glides.

Specification Information

Style Number	Base Price
4821412	\$876



Amia 482 Series Work Chair

Air Back with 3D Microknit and Upholstery on Seat

SIN 711.18



Tip: Amia Air frame packages include inner back frame and lumbar, outer back frame, arm holsters, outer seat shell, and base.

Tip: When merle, platinum, or seagull are selected as frame packages, the outer seat shell and inner back frame default to 7249 Merle plastic.

Tip: Always add suffixes in alphabetical order when specifying options to Amia seating.

Tip: Leather and vinyl upcharges are in addition to sewn upholstery upcharge.

► Detailed dimensions, Page 128

Standard Includes		Required to Specify
► Need help? Product details, page 124	<ul style="list-style-type: none"> • Frame package • Synchro-tilt mechanism • 5" pneumatic seat-height adjustment • Upright back lock • Rectilinear independent height-, width-, pivot-, and depth-adjustable arms and soft arm caps: black plastic • 3" seat depth adjustment • Passive seat edge angle • Air back with integrated LiveBack technology: plastic • Adjustable lumbar • 3D Microknit on back only • Standard upholstery design on seat: fabric price group 1 • 2½"-diameter, hard-composition, dual-wheel casters: black 	<ol style="list-style-type: none"> 1 Style number 2 Frame package color scheme (see below under Required Selections) 3 Fabric color number for upholstery on seat 4 Air back plastic color number 5 Options, if selected (see below) <p>► See <i>Surface Materials</i>, page 432.</p>

Required Selections	Price	Required to Specify
Frame Package Color Scheme		
• Black	No cost	Specify with 6205 Black.
• Merle	+\$ 48	Specify with 6527 Merle.
• Platinum	+\$ 48	Specify with 6249 Platinum.
• Seagull	+\$ 40	Specify with 6053 Seagull.

Options	Price	Required to Specify
Surface Materials		
Upholstery		
• Fabric price group 1	No cost	Specify fabric color number.
• Fabric price group 2	+\$ 10	Specify fabric color number.
• Fabric price group 3	+\$ 26	Specify fabric color number.
• Fabric price group 4	+\$ 35	Specify fabric color number.
• Fabric price group 5	+\$ 42	Specify fabric color number.
• Fabric price group 6	+\$ 51	Specify fabric color number.
• Fabric price group 7	+\$ 62	Specify fabric color number.
• Fabric price group 8	+\$ 77	Specify fabric color number.
• Fabric price group 9	+\$ 94	Specify fabric color number.
• Fabric price group 10	+\$109	Specify fabric color number.
• Steelcase leather upholstery	+\$142	Specify fabric color number.
• Select Surfaces leather price group 1	+\$142	Add suffix S to the style number and specify leather color number.
• Elmosoft leather upholstery	+\$169	Add suffix S to the style number and specify Elmosoft leather color number.
• Select Surfaces leather price group 2	+\$169	Add suffix S to the style number and specify Select Surfaces leather price group 2.
• Steelcase vinyl	+\$ 10	► See <i>Surface Materials Reference Manual</i> . Add suffix S to the style number and specify vinyl color number.
• Customer's Own Material (COM)	No cost	► See <i>Surface Materials Reference Manual</i> to specify.
• Customer's Own Leather (COL)	No cost	Add suffix S to the style number and specify leather color number.

Soil-retardant treatment	+\$ 25	Specify with soil-retardant treatment.
Sewn upholstery		
• Sewn upholstery on chair	+\$ 41	Add suffix S to the style number.
Base		
• Polished aluminum base	+\$149	Specify with polished aluminum base.
Arms		
• Height-adjustable arms, soft arm caps	-\$ 88	Specify with height-adjustable arms.
• Armless	-\$207	Specify without arms.

► Options, continued on next page

► Options, continued from previous page

	Options	Price	Required to Specify
Lumbar	• No lumbar	-\$26	Specify with no lumbar.
Seat Height	• 4" pneumatic seat-height adjustment	+\$58	Specify with 4" pneumatic seat-height adjustment.
	• 7" pneumatic seat-height adjustment	+\$58	Specify with 7" pneumatic seat-height adjustment.
Casters	• Soft, dark grey treaded, dual-wheel roll-control casters for use on hard floors	+\$25	Specify with soft roll-control casters.
	• Hard, polished aluminum casters on polished aluminum base for use on soft floors	+\$59	Specify with hard polished aluminum casters.
	• Soft, polished aluminum casters on polished aluminum base for use on hard floors	+\$83	Specify with soft polished aluminum casters.
Glides	• Glides: plastic	+\$25	Specify with glides.

Specification Information

Style Number	Base Price
4821414	\$931



Amia 482 Series Stool

Upholstery on Back and Seat

SIN 711.18

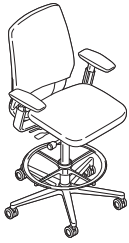

Tip: Frame packages include outer back shell, outer back frame, arm holsters, outer seat shell, and base.

Tip: Leather and vinyl upcharges are in addition to sewn upholstery upcharge.

Tip: Suffixes other than **K** for contrasting fabric, will be added in alphabetical order when specifying options. The contrasting fabric suffix, **K**, will always be at the end of the style number.

Standard Includes		Required to Specify
<ul style="list-style-type: none"> ▶ Need help? Product details, page 124 	<ul style="list-style-type: none"> • Synchro-tilt mechanism • 8" pneumatic seat-height adjustment • Upright back lock • Passive seat edge angle • Rectilinear independent height-, width-, pivot-, and depth-adjustable arms and soft arm caps: black plastic • Frame, seat shell, outer back, and five-arm base: plastic • 3" seat depth adjustment • Column and 4" adjustable foot ring: black • Standard upholstery design: fabric price group 1 • 2"-diameter, hard-composition, dual-wheel casters: black • Adjustable lumbar 	<ol style="list-style-type: none"> 1 Style number 2 Frame package color scheme (see below under Required Selections) 3 Fabric color number for upholstery on seat and back 4 Options, if selected (see below) <p>▶ See <i>Surface Materials</i>, page 432</p>

Required Selections	Price	Required to Specify
Frame Package Color Scheme		
• Black	No cost	Specify with 6205 Black.
• Merle	+\$ 48	Specify with 6527 Merle.
• Platinum	+\$ 48	Specify with 6249 Platinum.
• Seagull	+\$ 40	Specify with 6053 Seagull.

Options	Price	Required to Specify
Surface Materials		
Upholstery on seat and back		
• Fabric price group 1	No cost	Specify fabric color number.
• Fabric price group 2	+\$ 26	Specify fabric color number.
• Fabric price group 3	+\$ 48	Specify fabric color number.
• Fabric price group 4	+\$ 68	Specify fabric color number.
• Fabric price group 5	+\$ 85	Specify fabric color number.
• Fabric price group 6	+\$106	Specify fabric color number.
• Fabric price group 7	+\$121	Specify fabric color number.
• Fabric price group 8	+\$153	Specify fabric color number.
• Fabric price group 9	+\$188	Specify fabric color number.
• Fabric price group 10	+\$213	Specify fabric color number.
• Steelcase leather upholstery	+\$283	Add suffix S to the style number and specify leather color number.
• Select Surfaces leather price group 1	+\$283	Add suffix S to the style number and specify Select Surfaces leather price group 1.
		▶ See <i>Surface Materials Reference Manual</i> .
• Elmosoft leather upholstery	+\$337	Add suffix S to the style number and specify Elmosoft leather color number.
• Select Surfaces leather price group 2	+\$337	Add suffix S to the style number and specify Select Surfaces leather price group 2.
		▶ See <i>Surface Materials Reference Manual</i> .
• Steelcase vinyl	+\$ 26	Add suffix S to the style number and specify vinyl color number.
		▶ See <i>Surface Materials Reference Manual</i> to specify.
• Customer's Own Material (COM)	No cost	Add suffix S to the style number and specify leather color number.
• Customer's Own Leather (COL)	No cost	
Sewn upholstery		
• Sewn upholstery on chair	+\$ 77	Add suffix S to the style number.
Contrasting upholstery on seat and back		
• Contrasting fabrics	+\$ 31	Add suffix K to the style number and specify fabric color numbers.

▶ Options, continued on next page

▶ Detailed dimensions, Page 128

► Options, continued from previous page

Options	Price	Required to Specify
Surface Materials, continued		
Contrasting upholstery on seat		
• Fabric price group 1	No cost	Specify fabric color number.
• Fabric price group 2	+\$ 10	Specify fabric color number.
• Fabric price group 3	+\$ 26	Specify fabric color number.
• Fabric price group 4	+\$ 35	Specify fabric color number.
• Fabric price group 5	+\$ 42	Specify fabric color number.
• Fabric price group 6	+\$ 52	Specify fabric color number.
• Fabric price group 7	+\$ 62	Specify fabric color number.
• Fabric price group 8	+\$ 77	Specify fabric color number.
• Fabric price group 9	+\$ 94	Specify fabric color number.
• Fabric price group 10	+\$109	Specify fabric color number.
• Steelcase leather upholstery	+\$141	Add suffix S to the style number and specify leather color number.
• Select Surfaces leather price group 1	+\$141	Add suffix S to the style number and specify leather color number.
• Elmosoft leather upholstery	+\$168	Add suffix S to the style number and specify leather color number.
• Select Surfaces leather price group 2	+\$168	Add suffix S to the style number and specify leather color number.
• Customer's Own Material (COM)	No cost	► See <i>Surface Materials Reference Manual</i>
Contrasting upholstery on back		
• Fabric price group 1	No cost	Specify fabric color number.
• Fabric price group 2	+\$ 16	Specify fabric color number.
• Fabric price group 3	+\$ 22	Specify fabric color number.
• Fabric price group 4	+\$ 33	Specify fabric color number.
• Fabric price group 5	+\$ 43	Specify fabric color number.
• Fabric price group 6	+\$ 55	Specify fabric color number.
• Fabric price group 7	+\$ 59	Specify fabric color number.
• Fabric price group 8	+\$ 76	Specify fabric color number.
• Fabric price group 9	+\$ 94	Specify fabric color number.
• Fabric price group 10	+\$104	Specify fabric color number.
• Steelcase leather upholstery	+\$142	Add suffix S to the style number and specify leather color number.
• Select Surfaces leather price group 1	+\$142	Add suffix S to the style number and specify leather color number.
• Elmosoft leather upholstery	+\$169	Add suffix S to the style number and specify leather color number.
• Select Surfaces leather price group 2	+\$169	Add suffix S to the style number and specify leather color number.
• Customer's Own Material (COM)	No cost	► See <i>Surface Materials Reference Manual</i>
Soil-retardant treatment	+\$ 25	Specify with <i>soil-retardant treatment</i> .
Fire Code Seating (FCS)	+\$ 77	Add suffix F to the style number.
Fully upholstered		
• Fully upholstered with fabric	+\$129	Add suffix U to the style number.
• Fully upholstered with leather	+\$206	Add suffix SU to the style number.
• Steelcase leather fully upholstered outer back	+\$462	Add suffix SU to the style number and specify leather color number.
• Select Surfaces leather price group 1 fully upholstered outer back	+\$462	Add suffix SU to the style number and specify Select Surfaces leather price group 1.
• Elmosoft leather fully upholstered outer back	+\$544	► See <i>Surface Materials Reference Manual</i> Add suffix SU to the style number and specify Elmosoft leather color number.
• Select Surfaces leather price group 2 fully upholstered outer back	+\$544	Add suffix SU to the style number and specify Select Surfaces leather price group 2.
• Customer's Own Leather (COL) fully upholstered outer back	No cost	► See <i>Surface Materials Reference Manual</i> Add suffix SU to the style number. ► See <i>Surface Materials Reference Manual</i> to specify.

Tip: Leather and vinyl upcharges are in addition to sewn upholstery upcharge.

Tip: Fire Code Seating (FCS) option is available with certain upholstery fabric choices only.
► Page 462

Tip: Fire Code Seating (FCS) option is available on Amia chairs with fully adjustable arms or armless models only.

Tip: To get leather on a fully upholstered chair, you will need to add both the fully upholstered with leather upcharge and the upcharge for the leather itself.

► Options, continued on next page

Amia 482 Series Stool, Upholstery on Back and Seat, continued

SIN 711.18

► Options, continued from previous page

	Options	Price	Required to Specify
Arms	• Height-adjustable arms, soft arm caps	-\$ 88	Specify <i>with height-adjustable arms</i> .
	• Armless	-\$207	Specify <i>without arms</i> .
Casters	• Soft, dark grey treaded, dual-wheel roll-control casters for use on hard floors	+\$ 25	Specify <i>with soft roll-control casters</i> .
Glides	• Glides: plastic	+\$ 25	Specify <i>with glides</i> .

Specification Information

Style Number	Base Price
4827410	\$1234



SIN 711.18

Amia 482 Series Stool

3D Knit on Back with Upholstery on Seat

SIN 711.18



Standard Includes		Required to Specify
<ul style="list-style-type: none"> ▶ Need help? Product details, page 124 	<ul style="list-style-type: none"> • Synchro-tilt mechanism • 8" pneumatic seat-height adjustment • Upright back lock • Passive seat edge angle • Rectilinear independent height-, width-, pivot-, and depth-adjustable arms and soft arm caps: black plastic • Frame, seat shell, outer back, and five-arm base: plastic • 3" seat depth adjustment • Column and 4" adjustable foot ring: black • 3D Knit on back only • Standard upholstery design on seat: fabric price group 1 • 2"-diameter, hard-composition, dual-wheel casters: black • Adjustable lumbar 	<ol style="list-style-type: none"> 1 Style number 2 Frame package color scheme (see below under Required Selections) 3 3D Knit color for back 4 Fabric color number for upholstery on seat 5 Options, if selected (see below) <p>▶ See <i>Surface Materials</i>, page 432.</p>

Tip: Frame packages include outer back shell, outer back frame, arm holsters, outer seat shell, and base.

Required Selections	Price	Required to Specify
Frame Package	No cost	Specify with 6205 Black.
Color Scheme	+\$ 48	Specify with 6527 Merle.
• Black	+\$ 48	Specify with 6249 Platinum.
• Merle	+\$ 40	Specify with 6053 Seagull.
• Platinum		
• Seagull		

Options	Price	Required to Specify
Surface Materials		
Upholstery		
• Fabric price group 1	No cost	Specify fabric color number.
• Fabric price group 2	+\$ 10	Specify fabric color number.
• Fabric price group 3	+\$ 26	Specify fabric color number.
• Fabric price group 4	+\$ 35	Specify fabric color number.
• Fabric price group 5	+\$ 42	Specify fabric color number.
• Fabric price group 6	+\$ 51	Specify fabric color number.
• Fabric price group 7	+\$ 62	Specify fabric color number.
• Fabric price group 8	+\$ 77	Specify fabric color number.
• Fabric price group 9	+\$ 94	Specify fabric color number.
• Fabric price group 10	+\$109	Specify fabric color number.
• Steelcase leather upholstery	+\$142	Specify fabric color number. Add suffix S to the style number and specify leather color number.
• Select Surfaces leather price group 1	+\$142	Add suffix S to the style number and specify Select Surfaces leather price group 1. ▶ See <i>Surface Materials Reference Manual</i> .
• Elmosoft leather upholstery	+\$169	Add suffix S to the style number and specify Elmosoft leather color number.
• Select Surfaces leather price group 2	+\$169	Add suffix S to the style number and specify Select Surfaces leather price group 2. ▶ See <i>Surface Materials Reference Manual</i> .
• Steelcase vinyl	+\$ 10	Add suffix S to the style number and specify vinyl color number. ▶ See <i>Surface Materials Reference Manual</i> to specify.
• Customer's Own Material (COM)	No cost	Add suffix S to the style number and specify leather color number.
• Customer's Own Leather (COL)	No cost	
Fire Code Seating (FCS)	+\$ 77	Add suffix F to the style number.
Soil-retardant treatment	+\$ 25	Specify with soil-retardant treatment.
Sewn upholstery		
• Sewn upholstery on chair	+\$ 41	Add suffix S to the style number.
Arms		
• Height-adjustable arms, soft arm caps	-\$ 88	Specify with height-adjustable arms.
• Armless	-\$207	Specify without arms.

Tip: Always add suffixes in alphabetical order when specifying options to Amia seating.

Tip: Leather and vinyl upcharges are in addition to sewn upholstery upcharge.

Tip: Fire Code Seating (FCS) option is available with certain upholstery fabric choices only. ▶ Page 462

▶ Options, continued on next page

▶ Detailed dimensions, Page 128

SIN 711.18

► **Options, continued from previous page**

	Options	Price	Required to Specify
Casters	<ul style="list-style-type: none"> Soft, dark grey treaded, dual-wheel roll-control casters for use on hard floors 	+\$25	Specify with soft roll-control casters.
Glides	<ul style="list-style-type: none"> Glides: plastic 	+\$25	Specify with glides.

Specification Information

Style Number	Base Price
4827418	\$1293

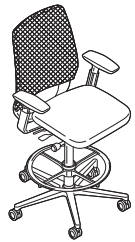

Amia 482 Series

Amia 482 Series Stool

Air Back with Upholstery on Seat

SIN 711.18



Tip: Amia Air frame packages include inner back frame and lumbar, outer back frame, arm holsters, outer seat shell, and base.

Tip: When merle, platinum, or seagull are selected as frame packages, the outer seat shell and inner back frame default to 6527 Merle plastic.

Tip: Always add suffixes in alphabetical order when specifying options to Amia seating.

Tip: Leather and vinyl upcharges are in addition to sewn upholstery upcharge.

► Detailed dimensions, Page 128

Standard Includes		Required to Specify
► Need help? Product details, page 124	<ul style="list-style-type: none"> • Frame package • Synchro-tilt mechanism • 8" pneumatic seat-height adjustment • Upright back lock • Passive seat edge angle • Rectilinear independent height-, width-, pivot-, and depth-adjustable arms and soft arm caps: black plastic • 3" seat depth adjustment • Column and 4" adjustable foot ring: black • Air back with integrated LiveBack technology: plastic • Standard upholstery design on seat: fabric price group 1 • 2"-diameter, hard-composition, dual-wheel casters: black 	<ol style="list-style-type: none"> 1 Style number 2 Frame package color scheme (see below under Required Selections) 3 Fabric color number for upholstery on seat 4 Air back plastic color number 5 Options, if selected (see below) <p>► See <i>Surface Materials</i>, page 432.</p>

Required Selections	Price	Required to Specify
Frame Package	• Black • Merle	No cost +\$ 48
Color Scheme	• Platinum • Seagull	+\$ 48 +\$ 40
		Specify with 6205 Black. Specify with 6527 Merle. Specify with 6249 Platinum. Specify with 6053 Seagull.

Options	Price	Required to Specify
Surface Materials		
Upholstery		
• Fabric price group 1	No cost	Specify fabric color number.
• Fabric price group 2	+\$ 10	Specify fabric color number.
• Fabric price group 3	+\$ 26	Specify fabric color number.
• Fabric price group 4	+\$ 35	Specify fabric color number.
• Fabric price group 5	+\$ 42	Specify fabric color number.
• Fabric price group 6	+\$ 51	Specify fabric color number.
• Fabric price group 7	+\$ 62	Specify fabric color number.
• Fabric price group 8	+\$ 77	Specify fabric color number.
• Fabric price group 9	+\$ 94	Specify fabric color number.
• Fabric price group 10	+\$109	Specify fabric color number.
• Steelcase leather upholstery	+\$142	Specify fabric color number.
• Select Surfaces leather price group 1	+\$142	Add suffix S to the style number and specify leather color number. Add suffix S to the style number and specify Select Surfaces leather price group 1.
• Elmosoft leather upholstery	+\$169	► See <i>Surface Materials Reference Manual</i> . Add suffix S to the style number and specify Elmosoft leather color number.
• Select Surfaces leather price group 2	+\$169	Add suffix S to the style number and specify Select Surfaces leather price group 2.
• Steelcase vinyl	+\$ 10	► See <i>Surface Materials Reference Manual</i> . Add suffix S to the style number and specify vinyl color number.
• Customer's Own Material (COM)	No cost	► See <i>Surface Materials Reference Manual</i> to specify.
• Customer's Own Leather (COL)	No cost	Add suffix S to the style number and specify leather color number.
Soil-retardant treatment	+\$ 25	Specify with <i>soil-retardant treatment</i> .
Sewn upholstery		
• Sewn upholstery on chair	+\$ 41	Add suffix S to the style number.
Arms		
• Height-adjustable arms, soft arm caps	-\$ 88	Specify with <i>height-adjustable arms</i> .
• Armless	-\$207	Specify <i>without arms</i> .
Casters		
• Soft, dark grey treaded, dual-wheel roll-control casters for use on hard floors	+\$ 25	Specify with <i>soft roll-control casters</i> .
Glides		
• Glides: plastic	+\$ 25	Specify with <i>glides</i> .

SIN 711.18

Specification Information

Style Number	Base Price
4827412	\$1071



Amia 482 Series

Amia 482 Series Stool

Air Back with 3D Microknit and Upholstery on Seat

SIN 711.18



Tip: Amia Air frame packages include inner back frame and lumbar, outer back frame, arm holsters, outer seat shell, and base.

Tip: Always add suffixes in alphabetical order when specifying options to Amia seating.

Tip: Leather and vinyl upcharges are in addition to sewn upholstery upcharge.

► Detailed dimensions, Page 128

Standard Includes		Required to Specify
► Need help? Product details, page 124	<ul style="list-style-type: none"> • Frame package • Synchro-tilt mechanism • 8" pneumatic seat-height adjustment • Upright back lock • Passive seat edge angle • Rectilinear independent height-, width-, pivot-, and depth-adjustable arms and soft arm caps: black plastic • 3" seat depth adjustment • Column and 4" adjustable foot ring: black • Air back with integrated LiveBack technology: plastic • Standard upholstery design on seat: fabric price group 1 • 2"-diameter, hard-composition, dual-wheel casters: black 	<ol style="list-style-type: none"> 1 Style number 2 Frame package color scheme (see below under Required Selections) 3 Fabric color number for upholstery on seat 4 Air back plastic color number 5 Options, if selected (see below) <p>► See <i>Surface Materials</i>, page 432.</p>

Required Selections	Price	Required to Specify
Frame Package Color Scheme		
• Black	No cost	Specify with 6205 Black.
• Merle	+\$ 48	Specify with 6527 Merle.
• Platinum	+\$ 48	Specify with 6249 Platinum.
• Seagull	+\$ 40	Specify with 6053 Seagull.

Options	Price	Required to Specify
Surface Materials		
Upholstery		
• Fabric price group 1	No cost	Specify fabric color number.
• Fabric price group 2	+\$ 10	Specify fabric color number.
• Fabric price group 3	+\$ 26	Specify fabric color number.
• Fabric price group 4	+\$ 35	Specify fabric color number.
• Fabric price group 5	+\$ 42	Specify fabric color number.
• Fabric price group 6	+\$ 51	Specify fabric color number.
• Fabric price group 7	+\$ 62	Specify fabric color number.
• Fabric price group 8	+\$ 77	Specify fabric color number.
• Fabric price group 9	+\$ 94	Specify fabric color number.
• Fabric price group 10	+\$109	Specify fabric color number.
• Steelcase leather upholstery	+\$142	Specify fabric color number.
• Select Surfaces leather price group 1	+\$142	Add suffix S to the style number and specify leather color number. Add suffix S to the style number and specify Select Surfaces leather price group 1.
• Elmosoft leather upholstery	+\$169	► See <i>Surface Materials Reference Manual</i> . Add suffix S to the style number and specify Elmosoft leather color number.
• Select Surfaces leather price group 2	+\$169	Add suffix S to the style number and specify Select Surfaces leather price group 2.
• Steelcase vinyl	+\$ 10	► See <i>Surface Materials Reference Manual</i> . Add suffix S to the style number and specify vinyl color number.
• Customer's Own Material (COM)	No cost	► See <i>Surface Materials Reference Manual</i> to specify.
• Customer's Own Leather (COL)	No cost	Add suffix S to the style number and specify leather color number.
Soil-retardant treatment	+\$ 25	Specify with soil-retardant treatment.
Sewn upholstery		
• Sewn upholstery on chair	+\$ 41	Add suffix S to the style number.
Arms		
• Height-adjustable arms, soft arm caps	-\$ 88	Specify with height-adjustable arms.
• Armless	-\$207	Specify without arms.
Casters		
• Soft, dark grey treaded, dual-wheel roll-control casters for use on hard floors	+\$ 25	Specify with soft roll-control casters.
Glides		
• Glides: plastic	+\$ 25	Specify with glides.

Specification Information

Style Number	Base Price
4827414	\$1126



Amia 482 Series

Reply 466 Series

Reply is a global family of value-friendly seating designed with unexpected extras.

Back frame and seat shell are plastic.

Back height adjustment on upholstered chairs allows you to raise or lower chair back from a seated position to support your lower back.

Five-arm base is plastic, a polished aluminum base is available as an option.

Arm tube matches the frame finish.

Arm support is coordinated to match the base finish.

Dual-wheel with roll-control casters may be used on soft and hard flooring surfaces.

Back handle on mesh back chairs provides a convenient handhold to easily move the chair.

Arms, when specified, have a textured plastic arm cap.

Lumbar height adjusts 4" to provide additional lower back support and is available as an option on mesh back chairs only.

Arm depth can retract 3" to allow user to get closer to the worksurface and into tight corners.

Arm height can adjust independently within a 3³/₄" range to help relieve upper back and shoulder fatigue.

Arm caps can pivot independently 18° in and 4° out to accommodate individual user preferences.

Arm width adjusts 1" per arm for a total of 2" overall width adjustment.

Multi-position back lock allows user to recline the back to the desired angle and lock it in place.

Seat depth adjusts within a 1¹/₂" range to accommodate users of varying leg lengths.

Seat height adjusts within a 5" range with a pneumatic adjustment mechanism.

Tilt tension adjustment allows you to control the amount of resistance needed for reclining.

Casters have hard, dual-wheels that roll smoothly on carpets. They are 2¹/₂" for increased mobility. Soft, dark grey treaded, dual-wheel casters are available as an option for use on hard floors or chair mats.
Tip: Do not roll the chair across asphalt during installation as this may damage the casters.

Plastic glides are standard. Optional soft glides are available.

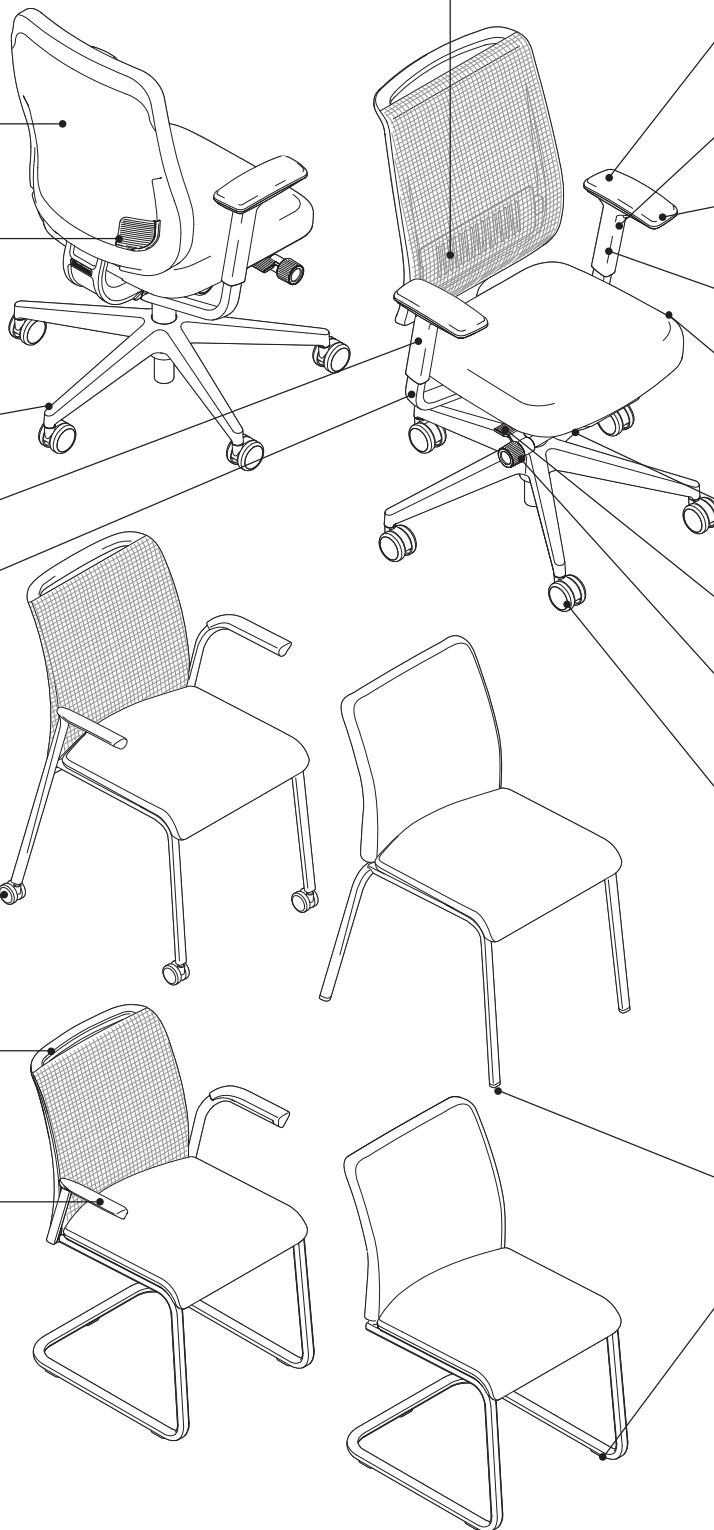

Product Details

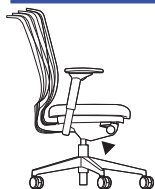

Synchro-tilt mechanism with a natural fluid motion on work chairs keeps users oriented to their work.

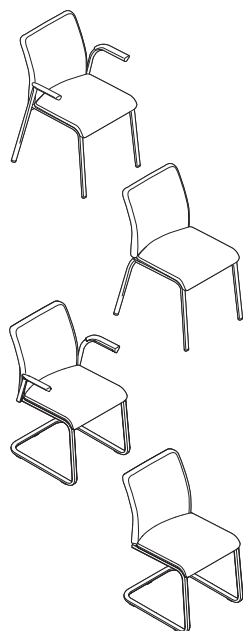

Fixed-height multi-use chairs are available with or without arms.

Cartoned shipment of Reply work chairs is standard. Reply work chairs ship knocked down in a single carton consisting of two components: the base, pneumatic, mechanism, and seat (built up as one component), and the back with the attachment knob. This allows for shipment in a smaller carton. Leg-base multi-use chairs ship two to a carton, when applicable. Assembly by a qualified dealer installer is required for work chairs. Assembly instructions are included. No additional tools are required for assembly.

Uncartoned request means Reply work chairs will ship fully assembled and blanket wrapped.

Stacking density for leg-base multi-use chairs is six on the floor. Arms and casters do not impact the ability to stack.

Adjustment Features

Adjustability instructions are included with every swivel-base chair. Instructions can also be found at www.steelcase.com.

Seat Adjustments

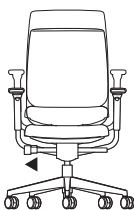

Seat height adjusts pneumatically. To lower, hold handle up while seated. To raise, hold handle up and keep your weight off the chair. Range of adjustability is 5", from 16"H to 21"H.

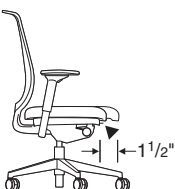

Seat depth adjusts 1½" by pulling handle up. Slide seat forward or back to accommodate various leg lengths. Release handle to lock. Seat depth is a standard feature on work chairs.

Back Adjustments

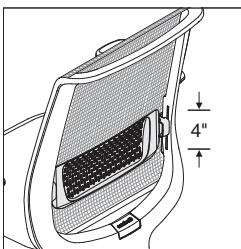

Lumbar height adjusts 4" (6" to 10" from seat) by grabbing exposed tabs and sliding the lumbar support up or down. Available as an option on mesh work chairs only.



Variable back lock (4 positions)

Upright setting

Multiple position back lock allows users to recline the back to the desired angle and lock it in place. To lock, recline to desired angle and push back lock handle down. To release, lean forward, lift the handle and apply pressure to the back to disengage the lock.

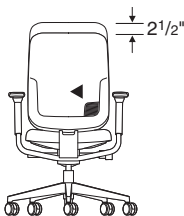

Back height adjusts 2½" (23"–25½") by pressing and holding the control button on the right side of the back, and sliding the back support up or down. Release the control button to lock. This feature is standard on work chairs with upholstered (non-mesh) backs only.

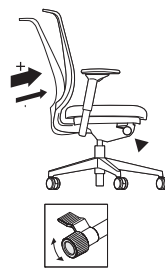

Back tension adjusts by turning knob forward to increase back tension, backward to decrease back tension. This feature is standard on all work chairs.

Arm Adjustments

Height-, pivot-, and depth-adjustable arms are available as an option on Reply task chairs.

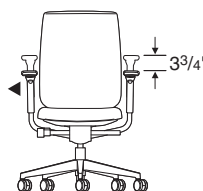

Arm height adjusts independently within a range of 3¾" (7½"–11¼" from the seat). Push button on outside and under arm cap in while moving arms up or down. Releasing buttons locks arms in position.

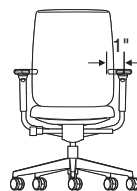

Width maintenance arms adjust 1" each independently on chairs with this option. To adjust, loosen the screw under the arm tube and move to desired position and tighten.

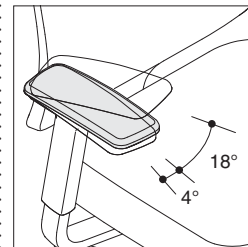

Arms pivot 18° inward and 4° outward on models with adjustable pivot arms. Grasp arm and push front to left or right.

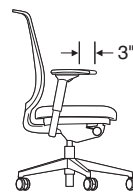

Arm depth adjusts approximately 3" to enable user to get closer to worksurface.

Other Features

Height-only adjustable arm is also available and adjusts 3¾".

Soft, dark grey treaded, dual-wheel roll-control casters are available as an option for use on hard floors or chair mats.

Dual-wheel roll-control casters for use on soft and hard flooring surfaces come standard on leg-base multi-use chairs when specified with casters.

Hard glides come standard on multi-use chairs when specified with glides. Soft glides are available as an option.

Reply 466 Series, continued

Surface Materials

► See surface materials on page 432 for specific availability or refer to the *Surface Materials Reference Manual* for further information.

Upholstery

- Fabric
- Fabric with soil-retardant treatment (option)
- Mesh (back only)
- Leather
- Elmosoft leather
- Select Surfaces leather
- Vinyl

Hard components

Chair with swivel-base (frame, outer back, arm cap assembly, and mechanism)

- 6205 Black

Chair with swivel-base and mesh back (frame and arm tube only)

- 6053 Seagull

Chair with swivel-base (arm support and base)

- 6205 Black
- 6249 Platinum
- Polished aluminum (base only)

Chair with multi-use leg-base (outer back, and arm caps)

- 6205 Black

Chair with leg-base or sled-base (metal frame)

- 4799 Platinum
- 7207 Black

Casters

- 6205 Black

Glides

Chair with multi-use leg-base

- 6205 Black

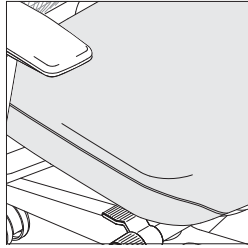

Sewn-upholstery models feature a stitch detail on the sides of the seat and back cushions. Task chairs have an additional stitch across the lumbar region of the back cushion.

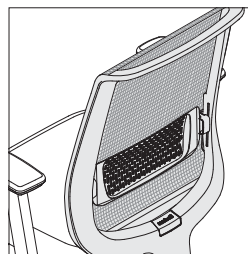
Swivel-Base Models

Mesh back on swivel-base models are available with a height-adjustable lumbar option to enhance back support.

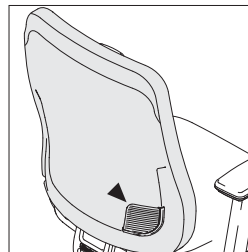

Upholstered back on swivel-base models feature a back-height adjustment that allows you to raise or lower the chair back from a seated position to support your lower back.

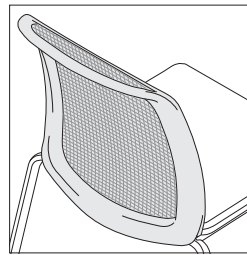
Leg-Base and Sled-Base Models

Mesh back frame with handle on leg-base models provides a convenient handhold to easily move the chair.

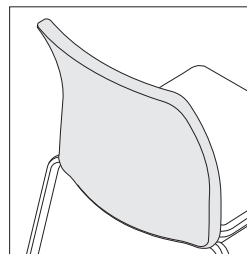

Upholstered back rest on leg-base models features a plastic outer shell.

All Steelcase seating with standard upholstery fabrics

complies with requirements of the State of California Technical Bulletin 117-2013. All standard seating is labeled to be in compliance with California 117-2013.

Programs & Services

► See *Surface Materials Reference Manual* for further detail about programs and services offered for seating.

The Customer's Own Material (COM) Program

offers the opportunity for customers to select fabrics that are not offered through the standard Steelcase surface materials program for use on Steelcase products. Through the COM program, Steelcase will test your materials for application on Steelcase products. Once approved, you can place your order. Steelcase will facilitate the entire ordering process and give you a production schedule. Steelcase will order the COM fabric directly from the textile manufacturer. For up-to-date information regarding fabric test results for all COM fabrics and details regarding yardage requirements for most Seating lines, visit the COM website. To locate the COM website:

- Visit www.steelcase.com

Soil retardants are treatments that provide long-term soil and stain resistance to a fabric without affecting the shade or the integrity of the fabric. The following Steelcase Textiles are available pre-treated with soil retardant. (You do not need to select the soil-retardant option for these fabrics and incur the upcharge.)

- Jacks
- Link
- Spyder

For information on soil-retardant fabrics on Select Surfaces, please refer to the *Surface Materials Reference Manual*.

Soil-retardant treatment is available on all other seating fabrics at an additional upcharge per seating unit. To order this option, please select "Soil-Retardant Treatment" under "Optional Accessories."

For soil-retardant treatment on COMs, please select "Soil-Retardant Treatment" under "Optional Accessories." Minimums or additional yardage may be required. Please contact the vendor directly for specific information.

Extended lead times may be necessary for this service.

Contact your Steelcase Solutions Fulfillment Team Representative at 1.888.STEELCASE (1.888.783.3522) or send an email to lineone@steelcase.com.

Dimensions

► Page 156

Resources**Printed materials**

- Reply Product Brochure (10-0002941)
- Reply User Guide (10-0002805)

Audiovisual materials

- Adjustability video available on www.steelcase.com

Online Resources

- Environmental profiles available on www.steelcase.com/sustainability

Dimensions

Reply 466 Series

Features	Overall Depth	Width	Height	Seat Depth	Functional Seat Depth	Seat Width	Seat Height from Floor	Back Width	Back Height from Seat	Lumbar Height from Seat
----------	---------------	-------	--------	------------	-----------------------	------------	------------------------	------------	-----------------------	-------------------------

Reply 466 Series

Swivel-Base Work Chairs

Mesh Back	24" to 25"	26"	37 ³ / ₄ " to 42 ³ / ₄ "	16 ⁷ / ₈ "	16 ¹ / ₂ " to 18"	18 ¹ / ₂ "	16" to 21"	17 ¹ / ₂ "	22 ⁵ / ₈ "	6" to 10"
Upholstered Back and Seat	21 ¹ / ₈ " to 22 ¹ / ₂ "	26"	39 ¹ / ₄ " to 46 ³ / ₄ "	16 ⁷ / ₈ "	15 ¹ / ₂ " to 17"	18 ¹ / ₂ "	16" to 21"	17 ¹ / ₂ "	23 ¹ / ₄ " to 25 ³ / ₄ "	N.A.

Leg-Base Multi-Use Chairs

Mesh Back	23"	23 ¹ / ₄ "*	34"***	17 ¹ / ₂ "	16"	17 ³ / ₄ "	19"***	16 ¹ / ₂ "	17"	9 ¹ / ₂ "
Upholstered	23"	23 ¹ / ₄ "*	33"***	17 ¹ / ₂ "	17"	17 ³ / ₄ "	19"***	16 ³ / ₄ "	17"	8"

Sled-Base Multi-Use Chairs

Mesh Back	23 ¹ / ₂ "	23 ¹ / ₄ "	33 ¹ / ₂ "	17 ¹ / ₂ "	16"	17 ³ / ₄ "	18 ¹ / ₂ "	16 ¹ / ₂ "	17"	9 ¹ / ₂ "
Upholstered	23 ¹ / ₂ "	23 ¹ / ₄ "	32 ¹ / ₂ "	17 ¹ / ₂ "	17"	17 ³ / ₄ "	18 ¹ / ₂ "	16 ³ / ₄ "	17"	8"

*Armless models are 1¹/₄" narrower.

**Dimension is 1/2" less when specified with glides.

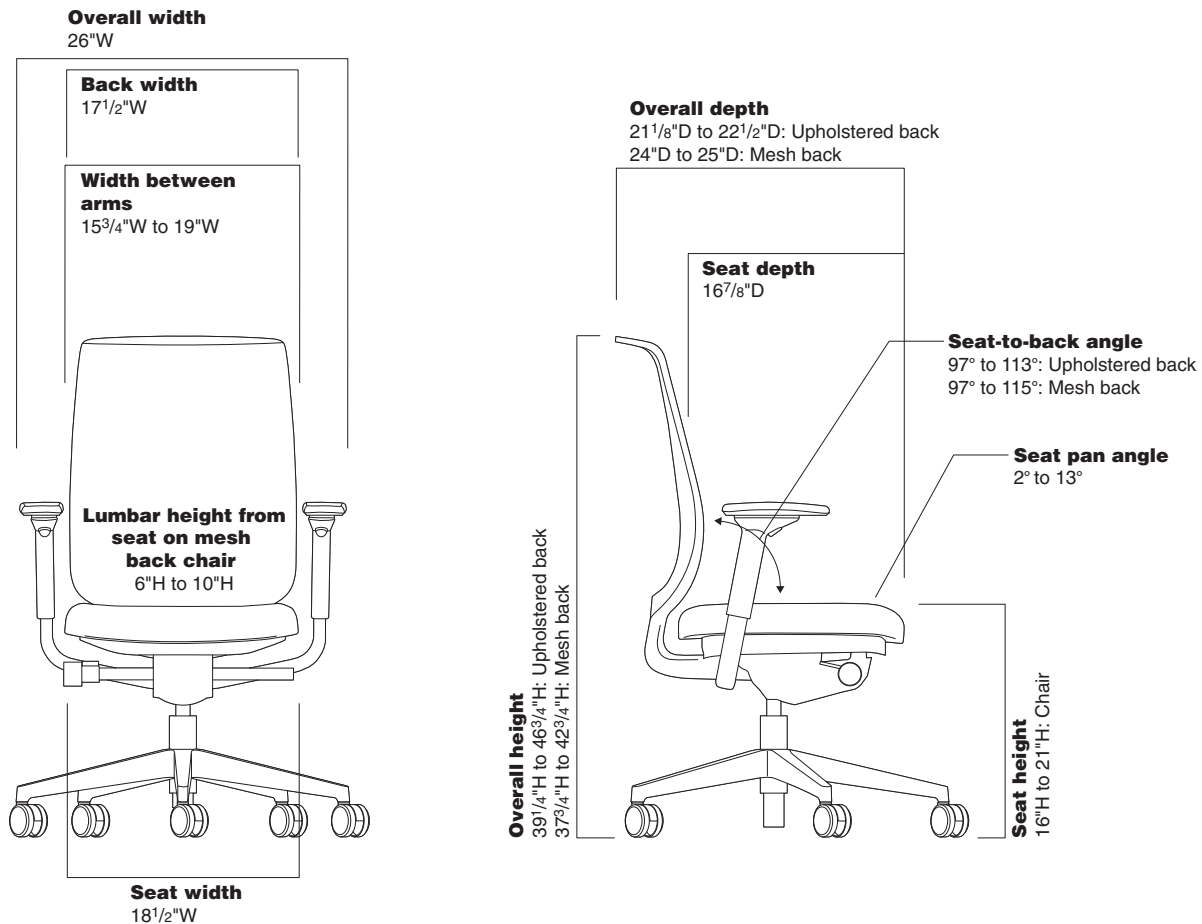

• Width • Between • Arms	• Arm • Height • to Floor	• Arm • Height • from • Seat	• Arm Cap • Pivot • Range	• Angle • Between • Seat and • Back	• Seat • Pan • Angle
Swivel-Base Work Chairs					
15¾" to 19"	23¼" to 32"	7¼" to 11"	18° inward, 4° outward	97° to 115°	2° to 13°
15¾" to 19"	23¼" to 32"	7¼" to 11"	18° inward, 4° outward	97° to 113°	2° to 13°
Leg-Base Multi-Use Chairs					
19½"	26¾"***	9"	N.A.	98°	6°
19½"	26¾"***	9"	N.A.	98°	6°
Sled-Base Multi-Use Chairs					
19½"	26¼"	9"	N.A.	98°	6°
19½"	26¼"	9"	N.A.	98°	6°
:	:	:	:	:	:

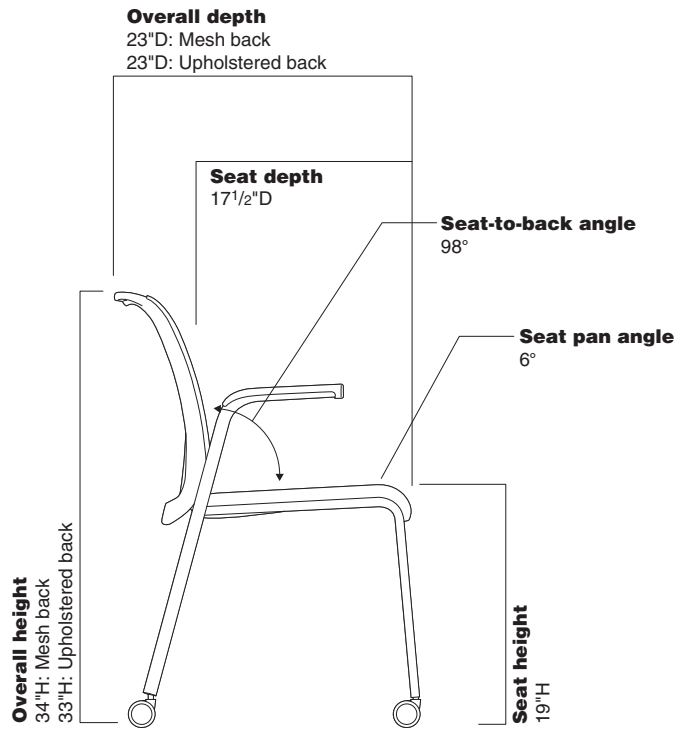
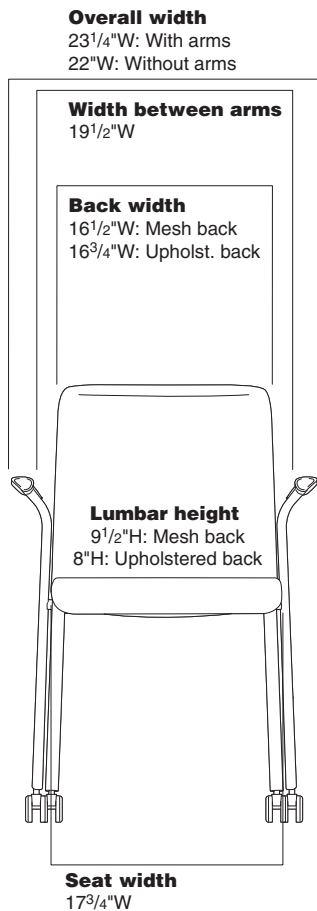

Reply 466 Series Swivel-Base Work Chair

Mesh Back with Standard Upholstery on Seat

SIN 711.18



Tip: Arms are not included with Reply unless you specify one of the arm options.

Tip: Always add suffixes in alphabetical order when specifying options to Reply seating.

Tip: Leather and vinyl upcharges are in addition to sewn upholstery upcharge.

Tip: Height-, width-, pivot-, depth-adjustable arms are maintenance width adjustable and are available in black only.

Tip: Frame color includes the frame and arm tube.

Tip: Seagull frame is available with 4799 Platinum arm supports only.

Tip: Black and polished aluminum bases are available with 6205 Black arm supports only. Platinum base is available with 4799 Platinum arm supports only.

► Detailed dimensions, page 156

Standard Includes		Required to Specify
► Need help? Product details, page 152	<ul style="list-style-type: none"> • Synchro-tilt mechanism • 5" pneumatic seat-height adjustment (16"-21") • Multi-position back lock • Outer back, seat shell, and five-arm plastic base: plastic • 1½" seat depth adjustment • Mesh on back • Standard upholstery design on seat: fabric price group 1 • 2½"-diameter, hard-composition, dual-wheel casters: black 	<ol style="list-style-type: none"> 1 Style number 2 Plastic color number for frame, arm tube, and base; if specified 3 Mesh color number for back 4 Fabric color number for upholstery on seat 5 Options, if selected (see below) <p>► See <i>Surface Materials</i>, page 432.</p>

Options	Price	Required to Specify	
Surface Materials			
Upholstery			
• Fabric price group 1	No cost	Specify fabric color number.	
• Fabric price group 2	+\$ 10	Specify fabric color number.	
• Fabric price group 3	+\$ 26	Specify fabric color number.	
• Fabric price group 4	+\$ 35	Specify fabric color number.	
• Fabric price group 5	+\$ 42	Specify fabric color number.	
• Fabric price group 6	+\$ 51	Specify fabric color number.	
• Fabric price group 7	+\$ 62	Specify fabric color number.	
• Fabric price group 8	+\$ 77	Specify fabric color number.	
• Fabric price group 9	+\$ 94	Specify fabric color number.	
• Fabric price group 10	+\$109	Specify fabric color number.	
• Steelcase leather upholstery	+\$136	Add suffix S to the style number and specify leather color number.	
• Select Surfaces leather price group 1	+\$136	Add suffix S to the style number and specify Select Surfaces leather price group 1.	
		► See <i>Surface Materials Reference Manual</i> .	
• Elmosoft leather upholstery	+\$166	Add suffix S to the style number and specify Elmosoft leather color number.	
• Select Surfaces leather price group 2	+\$166	Add suffix S to the style number and specify Select Surfaces leather price group 2.	
		► See <i>Surface Materials Reference Manual</i> .	
• Steelcase vinyl	+\$ 10	Add suffix S to the style number and specify vinyl color number.	
• Customer's Own Material (COM)	No cost	► See <i>Surface Materials Reference Manual</i> to specify.	
• Customer's Own Leather (COL)	No cost	Add suffix S to the style number and specify leather color number.	
Soil-retardant treatment	+\$ 25	Specify with soil-retardant treatment.	
Sewn upholstery			
• Sewn upholstery on chair	+\$ 41	Add suffix S to the style number.	
Arms			
• Height-adjustable arms, soft arm caps	+\$ 95	Specify with height-adjustable arms.	
• Height-, pivot-, depth-adjustable arms	+\$140	Specify with height-, pivot-, depth-adjustable arms.	
• Height-, width-, pivot-, depth-adjustable arms (maintenance width adjustment)	+\$179	Specify with height-, width-, pivot-, depth-adjustable arms.	
Frame			
• Black	No cost	Specify with 6205 Black.	
• Seagull	+\$ 27	Specify with 6053 Seagull.	
Base			
• Black	No cost	Specify with 6205 Black.	
• Platinum	+\$ 42	Specify with 4799 Platinum.	
• Polished aluminum	+\$149	Specify with aluminum base.	
Lumbar Height	• 4" travel for additional lumbar support	+\$ 39	Specify with adjustable lumbar height.
Casters	• Soft, dark grey treaded, dual-wheel roll-control casters for use on hard floors	+\$ 25	Specify with soft roll-control casters.

SIN 711.18

Specification Information

Style Number	Base Price
466160MT	\$717



Reply 466 Series

Reply 466 Series Swivel-Base Work Chair

Standard Upholstery on Back and Seat

SIN 711.18



Tip: Arms are not included with Reply unless you specify one of the arm options.

Tip: Leather and vinyl upcharges are in addition to sewn upholstery upcharge.

Standard Includes	Required to Specify
<ul style="list-style-type: none"> ▶ Need help? Product details, page 152 • Synchro-tilt mechanism • 5" pneumatic seat-height adjustment (16"-21") • Multi-position back lock • Outer back, seat shell, and five-arm plastic base: plastic • 1½" seat depth adjustment • 2¼" back-height adjustment • Standard upholstery design on back and seat: fabric price group 1 • 2½"-diameter, hard-composition, dual-wheel casters: black 	<ol style="list-style-type: none"> 1 Style number 2 Plastic color number for base, and arm tube; if specified 3 Fabric color number for upholstery on back and seat 4 Options, if selected (see below) <p>▶ See <i>Surface Materials</i>, page 432.</p>

Options	Price	Required to Specify
Surface Materials		
Upholstery on seat and back		
• Fabric price group 1	No cost	Specify fabric color number.
• Fabric price group 2	+\$ 26	Specify fabric color number.
• Fabric price group 3	+\$ 48	Specify fabric color number.
• Fabric price group 4	+\$ 68	Specify fabric color number.
• Fabric price group 5	+\$ 85	Specify fabric color number.
• Fabric price group 6	+\$106	Specify fabric color number.
• Fabric price group 7	+\$121	Specify fabric color number.
• Fabric price group 8	+\$153	Specify fabric color number.
• Fabric price group 9	+\$188	Specify fabric color number.
• Fabric price group 10	+\$213	Specify fabric color number.
• Steelcase leather upholstery	+\$278	Add suffix S to the style number and specify leather color number.
• Select Surfaces leather price group 1	+\$278	Add suffix S to the style number and specify Select Surfaces leather price group 1.
• Elmosoft leather upholstery	+\$336	▶ See <i>Surface Materials Reference Manual</i> . Add suffix S to the style number and specify Elmosoft leather color number.
• Select Surfaces leather price group 2	+\$336	Add suffix S to the style number and specify Select Surfaces leather price group 2.
• Steelcase vinyl	+\$ 26	▶ See <i>Surface Materials Reference Manual</i> . Add suffix S to the style number and specify vinyl color number.
• Customer's Own Material (COM)	No cost	▶ See <i>Surface Materials Reference Manual</i> to specify.
• Customer's Own Leather (COL)	No cost	Add suffix S to the style number and specify leather color number.
Sewn upholstery		
• Sewn upholstery on chair	+\$ 77	Add suffix S to the style number.
Contrasting upholstery on seat and back		
• Contrasting fabrics	+\$ 31	Add suffix K to the style number and specify fabric color numbers.
Contrasting upholstery on seat		
• Fabric price group 1	No cost	Specify fabric color number.
• Fabric price group 2	+\$ 10	Specify fabric color number.
• Fabric price group 3	+\$ 26	Specify fabric color number.
• Fabric price group 4	+\$ 35	Specify fabric color number.
• Fabric price group 5	+\$ 42	Specify fabric color number.
• Fabric price group 6	+\$ 51	Specify fabric color number.
• Fabric price group 7	+\$ 62	Specify fabric color number.
• Fabric price group 8	+\$ 77	Specify fabric color number.
• Fabric price group 9	+\$ 94	Specify fabric color number.
• Fabric price group 10	+\$109	Specify fabric color number.
• Steelcase leather upholstery	+\$139	Add suffix S to the style number and specify leather color number.
• Select Surfaces leather price group 1	+\$139	Add suffix S to the style number and specify leather color number.
• Elmosoft leather upholstery	+\$168	Add suffix S to the style number and specify leather color number.

▶ Detailed dimensions, page 156

▶ **Options, continued on next page**

SIN 711.18

► Options, continued from previous page

Options	Price	Required to Specify
Surface Materials, continued		
Contrasting upholstery on seat, continued		
• Select Surfaces leather price group 2	+\$168	Add suffix S to the style number and specify leather color number.
• Steelcase vinyl	+\$ 10	Add suffix S to the style number and specify vinyl color number.
• Customer's Own Material (COM)	No cost	► See <i>Surface Materials Reference Manual</i> . Add suffix S to the style number and specify leather color number.
• Customer's Own Leather (COL)	No cost	
Contrasting upholstery on back		
• Fabric price group 1	No cost	Specify fabric color number.
• Fabric price group 2	+\$ 16	Specify fabric color number.
• Fabric price group 3	+\$ 22	Specify fabric color number.
• Fabric price group 4	+\$ 33	Specify fabric color number.
• Fabric price group 5	+\$ 43	Specify fabric color number.
• Fabric price group 6	+\$ 55	Specify fabric color number.
• Fabric price group 7	+\$ 59	Specify fabric color number.
• Fabric price group 8	+\$ 76	Specify fabric color number.
• Fabric price group 9	+\$ 94	Specify fabric color number.
• Fabric price group 10	+\$104	Specify fabric color number.
• Steelcase leather upholstery	+\$139	Add suffix S to the style number and specify leather color number.
• Select Surfaces leather price group 1	+\$139	Add suffix S to the style number and specify leather color number.
• Elmosoft leather upholstery	+\$168	Add suffix S to the style number and specify leather color number.
• Select Surfaces leather price group 2	+\$168	Add suffix S to the style number and specify leather color number.
• Steelcase vinyl	+\$ 16	Add suffix S to the style number and specify vinyl color number.
• Customer's Own Material (COM)	No cost	► See <i>Surface Materials Reference Manual</i> . Add suffix S to the style number and specify leather color number.
• Customer's Own Leather (COL)	No cost	
Soil-retardant treatment		
	+\$ 25	Specify with <i>soil-retardant treatment</i> .
Platinum		
• On base, and arm tube	+\$ 48	Specify with <i>4799 Platinum</i> .
Arms		
• Height-adjustable arms, soft arm caps	+\$ 95	Specify with <i>height-adjustable arms</i> .
• Height-, pivot-, depth-adjustable arms	+\$140	Specify with <i>height-, pivot-, depth-adjustable arms</i> .
• Height-, width-, pivot-, depth-adjustable arms (maintenance width adjustment)	+\$179	Specify with <i>height-, width-, pivot-, depth-adjustable arms</i> .
Base		
• Polished aluminum base	+\$149	Specify with <i>aluminum base</i> .
Casters		
• Soft, dark grey treaded, dual-wheel roll-control casters for use on hard floors	+\$ 25	Specify with <i>soft roll-control casters</i> .

Tip: Leather and vinyl upcharges are in addition to sewn upholstery upcharge.

Tip: Height-, width-, pivot-, depth-adjustable arms are maintenance width adjustable and are available in black only.

Tip: Outer back, mechanism, and optional arm cap assembly are available in 6205 Black only.



Specification Information

Style Number	Base Price
466160MP	\$683

Reply 466 Series Leg-Base Multi-Use Chairs

Mesh Back with Standard Upholstery on Seat

SIN 711.18

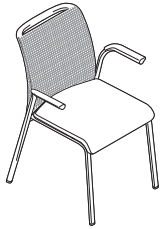

Tip: Leather and vinyl upcharges are in addition to sewn upholstery upcharge.

Tip: Casters or glides must be selected to complete specification of chair.

Standard Includes	Required to Specify
<ul style="list-style-type: none"> ▶ Need help? Product details, page 152 • Frame: paint • Mesh on back • Standard upholstery design on seat: fabric price group 1 • Arm caps, if selected: black 	<ol style="list-style-type: none"> 1 Style number 2 Paint color number for metal frame, and arms; if specified 3 Mesh color number for back 4 Fabric color number for upholstery on seat 5 Options, if selected (see below) <p>▶ See <i>Surface Materials</i>, page 432.</p>

Options	Price	Required to Specify
<p>Surface Materials</p> <p>Upholstery on seat</p> <ul style="list-style-type: none"> • Fabric price group 1 • Fabric price group 2 • Fabric price group 3 • Fabric price group 4 • Fabric price group 5 • Fabric price group 6 • Fabric price group 7 • Fabric price group 8 • Fabric price group 9 • Fabric price group 10 • Steelcase leather upholstery <ul style="list-style-type: none"> • Select Surfaces leather price group 1 • Elmosoft leather upholstery • Select Surfaces leather price group 2 • Steelcase vinyl • Customer's Own Material (COM) • Customer's Own Leather (COL) <p>Soil-retardant treatment</p> <p>Sewn upholstery</p> <ul style="list-style-type: none"> • Sewn upholstery on chair <p>Frame</p> <ul style="list-style-type: none"> • Platinum on frame 	<p>No cost</p> <p>+\$ 10</p> <p>+\$ 26</p> <p>+\$ 35</p> <p>+\$ 42</p> <p>+\$ 51</p> <p>+\$ 62</p> <p>+\$ 77</p> <p>+\$ 94</p> <p>+\$109</p> <p>+\$136</p> <p>+\$136</p> <p>+\$166</p> <p>+\$166</p> <p>+\$ 26</p> <p>No cost</p> <p>No cost</p> <p>+\$ 25</p> <p>+\$ 41</p> <p>+\$ 57</p> <p>+\$ 48</p> <p>No cost</p> <p>+\$ 6</p>	<p>Specify fabric color number.</p> <p>Specify fabric color number.</p> <p>Specify fabric color number.</p> <p>Specify fabric color number.</p> <p>Specify fabric color number.</p> <p>Specify fabric color number.</p> <p>Specify fabric color number.</p> <p>Specify fabric color number.</p> <p>Specify fabric color number.</p> <p>Specify fabric color number.</p> <p>Specify fabric color number.</p> <p>Add suffix S to the style number and specify leather color number.</p> <p>Add suffix S to the style number and specify Select Surfaces leather price group 1.</p> <p>▶ See <i>Surface Materials Reference Manual</i>. Add suffix S to the style number and specify Elmosoft leather color number.</p> <p>Add suffix S to the style number and specify Select Surfaces leather price group 2.</p> <p>▶ See <i>Surface Materials Reference Manual</i>. Add suffix S to the style number and specify vinyl color number.</p> <p>▶ See <i>Surface Materials Reference Manual</i> to specify.</p> <p>Add suffix S to the style number and specify leather color number.</p> <p>Specify <i>with soil-retardant treatment</i>.</p> <p>Add suffix S to the style number.</p> <p>Specify <i>with 4799 Platinum frame</i>.</p> <p>Specify <i>with dual-wheel roll-control casters</i>.</p> <p>Specify <i>with hard glides</i>.</p> <p>Specify <i>with soft glides</i>.</p>
<p>Casters</p> <ul style="list-style-type: none"> • Dual-wheel roll-control casters 		
<p>Glides</p> <ul style="list-style-type: none"> • Hard glides for use on carpeted floors • Soft glides for use on non-carpeted floors 		

▶ Detailed dimensions, page 156

SIN 711.18

Specification Information

With Arms



• **Style**
• **Number**

466452MT

• **Base**
• **Price**

\$563

Without Arms



• **Style**
• **Number**

466450MT

• **Base**
• **Price**

\$507

Reply 466 Series Leg-Base Multi-Use Chairs

Standard Upholstery on Back and Seat

SIN 711.18

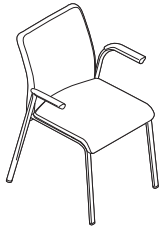

Tip: Leather and vinyl upcharges are in addition to sewn upholstery upcharge.

Tip: Suffixes other than **K** for contrasting fabric, will be added in alphabetical order when specifying options. The contrasting fabric suffix, **K**, will always be at the end of the style number.

Standard Includes		Required to Specify	
<ul style="list-style-type: none"> ▶ Need help? Product details, page 152 	<ul style="list-style-type: none"> • Frame: paint • Standard upholstery design on seat and back: fabric price group 1 • Arm caps, if selected: black 	<ol style="list-style-type: none"> 1 Style number 2 Paint color number for metal frame, and arms; if specified 3 Fabric color number for upholstery on seat and back 4 Options, if selected (see below) 	<ul style="list-style-type: none"> ▶ See <i>Surface Materials</i>, page 432.

Options	Price	Required to Specify	
Surface Materials	Upholstery on seat and back		
• Fabric price group 1	No cost	Specify fabric color number.	
• Fabric price group 2	+\$ 26	Specify fabric color number.	
• Fabric price group 3	+\$ 48	Specify fabric color number.	
• Fabric price group 4	+\$ 68	Specify fabric color number.	
• Fabric price group 5	+\$ 85	Specify fabric color number.	
• Fabric price group 6	+\$106	Specify fabric color number.	
• Fabric price group 7	+\$121	Specify fabric color number.	
• Fabric price group 8	+\$153	Specify fabric color number.	
• Fabric price group 9	+\$188	Specify fabric color number.	
• Fabric price group 10	+\$213	Specify fabric color number.	
• Steelcase leather upholstery	+\$278	Add suffix S to the style number and specify leather color number.	
• Select Surfaces leather price group 1	+\$278	Add suffix S to the style number and specify Select Surfaces leather price group 1.	▶ See <i>Surface Materials Reference Manual</i> .
• Elmosoft leather upholstery	+\$336	Add suffix S to the style number and specify Elmosoft leather color number.	
• Select Surfaces leather price group 2	+\$336	Add suffix S to the style number and specify Select Surfaces leather price group 2.	▶ See <i>Surface Materials Reference Manual</i> .
• Steelcase vinyl	+\$ 26	Add suffix S to the style number and specify vinyl color number.	▶ See <i>Surface Materials Reference Manual</i> to specify.
• Customer's Own Material (COM)	No cost	Add suffix S to the style number and specify leather color number.	
• Customer's Own Leather (COL)	No cost		
Sewn upholstery			
• Sewn upholstery on chair	+\$ 77	Add suffix S to the style number.	
Contrasting upholstery on seat and back			
• Contrasting fabrics	+\$ 31	Add suffix K to the style number and specify fabric color numbers.	
Contrasting upholstery on seat			
• Fabric price group 1	No cost	Specify fabric color number.	
• Fabric price group 2	+\$ 10	Specify fabric color number.	
• Fabric price group 3	+\$ 26	Specify fabric color number.	
• Fabric price group 4	+\$ 35	Specify fabric color number.	
• Fabric price group 5	+\$ 42	Specify fabric color number.	
• Fabric price group 6	+\$ 51	Specify fabric color number.	
• Fabric price group 7	+\$ 62	Specify fabric color number.	
• Fabric price group 8	+\$ 77	Specify fabric color number.	
• Fabric price group 9	+\$ 94	Specify fabric color number.	
• Fabric price group 10	+\$109	Specify fabric color number.	
• Steelcase leather upholstery	+\$139	Add suffix S to the style number and specify leather color number.	
• Select Surfaces leather price group 1	+\$139	Add suffix S to the style number and specify leather color number.	
• Elmosoft leather upholstery	+\$168	Add suffix S to the style number and specify leather color number.	

▶ Options, continued on next page

▶ Detailed dimensions, page 156

► Options, continued from previous page

Options	Price	Required to Specify
Surface Materials, continued		
Contrasting upholstery on seat, continued		
• Select Surfaces leather price group 2	+\$168	Add suffix S to the style number and specify leather color number. Add suffix S to the style number and specify vinyl color number. ► See <i>Surface Materials Reference Manual</i> . Add suffix S to the style number and specify leather color number.
• Steelcase vinyl	+\$ 10	
• Customer's Own Material (COM)	No cost	
• Customer's Own Leather (COL)	No cost	
Contrasting upholstery on back		
• Fabric price group 1	No cost	Specify fabric color number. Specify fabric color number. Specify fabric color number. Specify fabric color number. Specify fabric color number. Specify fabric color number. Specify fabric color number. Specify fabric color number. Specify fabric color number. Specify fabric color number. Add suffix S to the style number and specify leather color number. Add suffix S to the style number and specify leather color number. Add suffix S to the style number and specify leather color number. Add suffix S to the style number and specify leather color number. Add suffix S to the style number and specify vinyl color number. ► See <i>Surface Materials Reference Manual</i> . Add suffix S to the style number and specify leather color number.
• Fabric price group 2	+\$ 16	
• Fabric price group 3	+\$ 22	
• Fabric price group 4	+\$ 33	
• Fabric price group 5	+\$ 43	
• Fabric price group 6	+\$ 55	
• Fabric price group 7	+\$ 59	
• Fabric price group 8	+\$ 76	
• Fabric price group 9	+\$ 94	
• Fabric price group 10	+\$104	
• Steelcase leather upholstery	+\$139	
• Select Surfaces leather price group 1	+\$139	
• Elmosoft leather upholstery	+\$168	
• Select Surfaces leather price group 2	+\$168	
• Steelcase vinyl	+\$ 16	
• Customer's Own Material (COM)	No cost	
• Customer's Own Leather (COL)	No cost	
Soil-retardant treatment		
	+\$ 25	Specify with <i>soil-retardant treatment</i> .
Frame		
• Platinum on frame	+\$ 57	Specify with <i>4799 Platinum frame</i> .
Casters		
• Dual-wheel roll-control casters	+\$ 48	Specify with <i>dual-wheel roll-control casters</i> .
Glides		
• Hard glides for use on carpeted floors	No cost	Specify with <i>hard glides</i> .
• Soft glides for use on non-carpeted floors	+\$ 6	Specify with <i>soft glides</i> .

Tip: Leather and vinyl upcharges are in addition to sewn upholstery upcharge.

Tip: Casters or glides must be selected to complete specification of chair.

Reply 466 Series

Specification Information

With Arms



• Style Number

466452MH

• Base Price

\$507

Without Arms



• Style Number

466450MH

• Base Price

\$451

Reply 466 Series Sled-Base Multi-Use Chairs

Mesh Back with Standard Upholstery on Seat

SIN 711.18

Standard Includes		Required to Specify
<ul style="list-style-type: none"> ▶ Need help? Product details, page 152 	<ul style="list-style-type: none"> • Frame: paint • Mesh on back • Standard upholstery design on seat: fabric price group 1 • Arm caps, if selected: black 	<ol style="list-style-type: none"> 1 Style number 2 Paint color number for metal frame, and arms; if specified 3 Mesh color number for back 4 Fabric color number for upholstery on seat 5 Options, if selected (see below) <ul style="list-style-type: none"> ▶ See <i>Surface Materials</i>, page 432.



Options	Price	Required to Specify
Surface Materials		
Upholstery on seat		
• Fabric price group 1	No cost	Specify fabric color number.
• Fabric price group 2	+\$ 10	Specify fabric color number.
• Fabric price group 3	+\$ 26	Specify fabric color number.
• Fabric price group 4	+\$ 35	Specify fabric color number.
• Fabric price group 5	+\$ 42	Specify fabric color number.
• Fabric price group 6	+\$ 51	Specify fabric color number.
• Fabric price group 7	+\$ 62	Specify fabric color number.
• Fabric price group 8	+\$ 77	Specify fabric color number.
• Fabric price group 9	+\$ 94	Specify fabric color number.
• Fabric price group 10	+\$109	Specify fabric color number.
• Steelcase leather upholstery	+\$136	Add suffix S to the style number and specify leather color number.
• Select Surfaces leather price group 1	+\$136	Add suffix S to the style number and specify Select Surfaces leather price group 1.
• Elmosoft leather upholstery	+\$166	▶ See <i>Surface Materials Reference Manual</i> . Add suffix S to the style number and specify Elmosoft leather color number.
• Select Surfaces leather price group 2	+\$166	Add suffix S to the style number and specify Select Surfaces leather price group 2.
• Steelcase vinyl	+\$ 10	▶ See <i>Surface Materials Reference Manual</i> . Add suffix S to the style number and specify vinyl color number.
• Customer's Own Material (COM)	No cost	▶ See <i>Surface Materials Reference Manual</i> to specify.
• Customer's Own Leather (COL)	No cost	Add suffix S to the style number and specify leather color number.
Soil-retardant treatment		
	+\$ 25	Specify <i>with soil-retardant treatment</i> .
Sewn upholstery		
• Sewn upholstery on chair	+\$ 41	Add suffix S to the style number.
Frame		
• Platinum on frame	+\$ 57	Specify <i>with 4799 Platinum frame</i> .

Tip: Leather and vinyl upcharges are in addition to sewn upholstery upcharge.

Tip: Glides must be selected to complete specification of the chair.

Glides	Price	Required to Specify
• Hard glides for use on carpeted floors	No cost	Specify <i>with hard glides</i> .
• Soft glides for use on non-carpeted floors	+\$ 6	Specify <i>with soft glides</i> .

Specification Information

With Arms		Without Arms	
			
• Style Number	• Base Price	• Style Number	• Base Price
466482MT	\$597	466480MT	\$541

▶ Detailed dimensions, page 156

Reply 466 Series Sled-Base Multi-Use Chairs

Standard Upholstery on Back and Seat

SIN 711.18

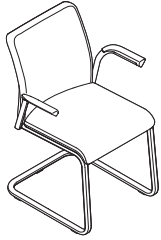

Tip: Leather and vinyl upcharges are in addition to sewn upholstery upcharge.

Tip: Suffixes other than **K** for contrasting fabric, will be added in alphabetical order when specifying options. The contrasting fabric suffix, **K**, will always be at the end of the style number.

Standard Includes	Required to Specify
<ul style="list-style-type: none"> ▶ Need help? Product details, page 152 • Frame: paint • Standard upholstery design on seat and back: fabric price group 1 • Arm caps, if selected: black 	<ol style="list-style-type: none"> 1 Style number 2 Paint color number for metal frame, and arms; if specified 3 Fabric color number for upholstery on seat and back 4 Options, if selected (see below) <p>▶ See <i>Surface Materials</i>, page 432.</p>

Surface Materials	Options	Price	Required to Specify
	Upholstery on seat and back		
	• Fabric price group 1	No cost	Specify fabric color number.
	• Fabric price group 2	+\$ 26	Specify fabric color number.
	• Fabric price group 3	+\$ 48	Specify fabric color number.
	• Fabric price group 4	+\$ 68	Specify fabric color number.
	• Fabric price group 5	+\$ 85	Specify fabric color number.
	• Fabric price group 6	+\$106	Specify fabric color number.
	• Fabric price group 7	+\$121	Specify fabric color number.
	• Fabric price group 8	+\$153	Specify fabric color number.
	• Fabric price group 9	+\$188	Specify fabric color number.
	• Fabric price group 10	+\$213	Specify fabric color number.
	• Steelcase leather upholstery	+\$278	Add suffix S to the style number and specify leather color number.
	• Select Surfaces leather price group 1	+\$278	Add suffix S to the style number and specify Select Surfaces leather price group 1.
	• Elmosoft leather upholstery	+\$336	▶ See <i>Surface Materials Reference Manual</i> . Add suffix S to the style number and specify Elmosoft leather color number.
	• Select Surfaces leather price group 2	+\$336	Add suffix S to the style number and specify Select Surfaces leather price group 2.
	• Steelcase vinyl	+\$ 26	▶ See <i>Surface Materials Reference Manual</i> . Add suffix S to the style number and specify vinyl color number.
	• Customer's Own Material (COM)	No cost	▶ See <i>Surface Materials Reference Manual</i> to specify.
	• Customer's Own Leather (COL)	No cost	Add suffix S to the style number and specify leather color number.
	Sewn upholstery		
	• Sewn upholstery on chair	+\$ 41	Add suffix S to the style number.
	Contrasting upholstery on seat and back		
	• Contrasting fabrics	+\$ 31	Add suffix K to the style number and specify fabric color numbers.
	Contrasting upholstery on seat		
	• Fabric price group 1	No cost	Specify fabric color number.
	• Fabric price group 2	+\$ 10	Specify fabric color number.
	• Fabric price group 3	+\$ 26	Specify fabric color number.
	• Fabric price group 4	+\$ 35	Specify fabric color number.
	• Fabric price group 5	+\$ 42	Specify fabric color number.
	• Fabric price group 6	+\$ 51	Specify fabric color number.
	• Fabric price group 7	+\$ 62	Specify fabric color number.
	• Fabric price group 8	+\$ 77	Specify fabric color number.
	• Fabric price group 9	+\$ 94	Specify fabric color number.
	• Fabric price group 10	+\$ 109	Specify fabric color number.
	• Steelcase leather upholstery	+\$139	Add suffix S to the style number and specify leather color number.
	• Select Surfaces leather price group 1	+\$139	Add suffix S to the style number and specify leather color number.
	• Elmosoft leather upholstery	+\$168	Add suffix S to the style number and specify leather color number.

▶ Options, continued on next page

▶ Detailed dimensions, page 156

► Options, continued from previous page

Tip: Leather and vinyl upcharges are in addition to sewn upholstery upcharge.

Options	Price	Required to Specify
Surface Materials, continued		
Contrasting upholstery on seat, continued		
• Select Surfaces leather price group 2	+\$168	Add suffix S to the style number and specify leather color number.
• Steelcase vinyl	+\$ 10	Add suffix S to the style number and specify vinyl color number.
• Customer's Own Material (COM)	No cost	► See <i>Surface Materials Reference Manual</i> . Add suffix S to the style number and specify leather color number.
• Customer's Own Leather (COL)	No cost	
Contrasting upholstery on back		
• Fabric price group 1	No cost	Specify fabric color number.
• Fabric price group 2	+\$ 16	Specify fabric color number.
• Fabric price group 3	+\$ 22	Specify fabric color number.
• Fabric price group 4	+\$ 33	Specify fabric color number.
• Fabric price group 5	+\$ 43	Specify fabric color number.
• Fabric price group 6	+\$ 55	Specify fabric color number.
• Fabric price group 7	+\$ 59	Specify fabric color number.
• Fabric price group 8	+\$ 76	Specify fabric color number.
• Fabric price group 9	+\$ 94	Specify fabric color number.
• Fabric price group 10	+\$104	Specify fabric color number.
• Steelcase leather upholstery	+\$139	Add suffix S to the style number and specify leather color number.
• Select Surfaces leather price group 1	+\$139	Add suffix S to the style number and specify leather color number.
• Elmosoft leather upholstery	+\$168	Add suffix S to the style number and specify leather color number.
• Select Surfaces leather price group 2	+\$168	Add suffix S to the style number and specify leather color number.
• Steelcase vinyl	+\$ 16	Add suffix S to the style number and specify vinyl color number.
• Customer's Own Material (COM)	No cost	► See <i>Surface Materials Reference Manual</i> . Add suffix S to the style number and specify leather color number.
• Customer's Own Leather (COL)	No cost	
Soil-retardant treatment		
	+\$ 25	Specify <i>with soil-retardant treatment</i> .
Frame		
• Platinum on frame	+\$ 57	Specify <i>with 4799 Platinum frame</i> .
Glides		
• Hard glides for use on carpeted floors	No cost	Specify <i>with hard glides</i> .
• Soft glides for use on non-carpeted floors	+\$ 6	Specify <i>with soft glides</i> .

Tip: Glides must be selected to complete specification of the chair.

Specification Information

With Arms



• Style Number

• Base Price

466482MH

\$541

Without Arms



• Style Number

• Base Price

466480MH

\$485

Jersey Series

Jersey features a double mesh back in a unique ergonomic "S" shape to conform to each user for comfort and support.

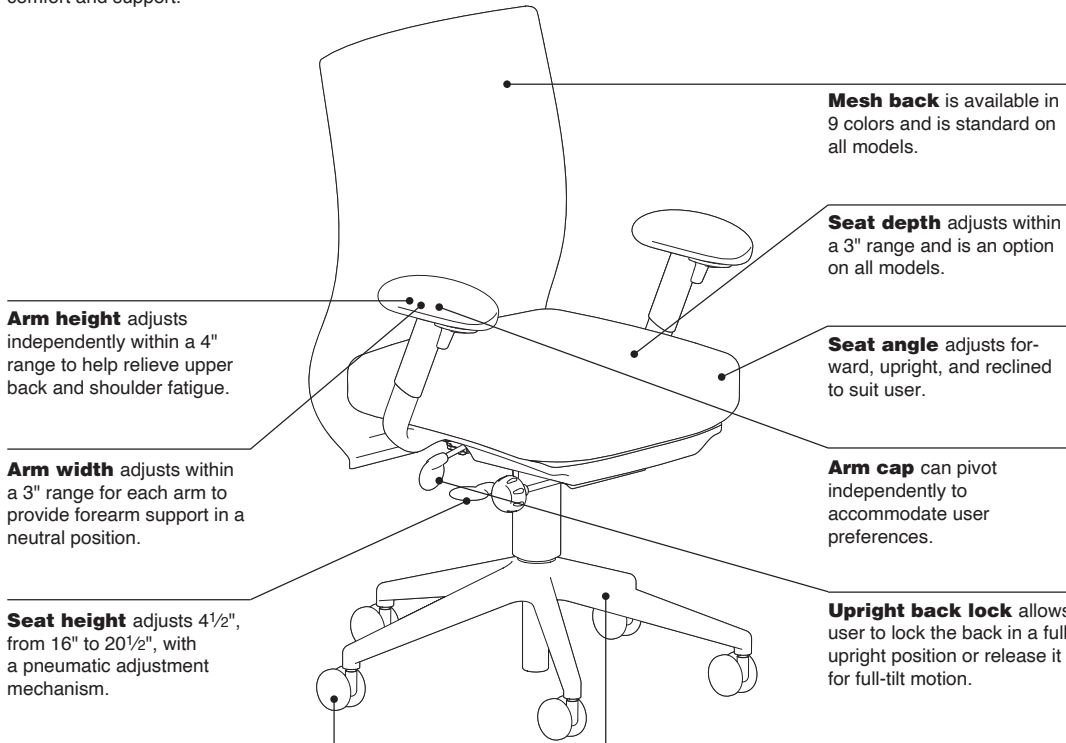

Mesh back is available in 9 colors and is standard on all models.

Seat depth adjusts within a 3" range and is an option on all models.

Seat angle adjusts forward, upright, and reclined to suit user.

Arm height adjusts independently within a 4" range to help relieve upper back and shoulder fatigue.

Arm width adjusts within a 3" range for each arm to provide forearm support in a neutral position.

Arm cap can pivot independently to accommodate user preferences.

Seat height adjusts 4½", from 16" to 20½", with a pneumatic adjustment mechanism.

Upright back lock allows user to lock the back in a full upright position or release it for full-tilt motion.

Five-arm base is plastic on 6205 Black frame models. Base is aluminum on 4799 Platinum models.

Casters have hard, dual-wheels that roll smoothly on carpets. They are 2½" for increased mobility. Soft, dual-wheel casters are available for use on hard floors or chair mats.
Tip: Do not roll the chair across asphalt during installation as this may damage the casters.

Product Details



Jersey work chairs are available armless, with fixed arms, with height and maintenance width-adjustable arms, and with height-, width-, and pivot-adjustable arms.

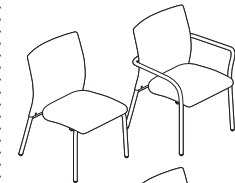

Multi-use chairs are available with or without arms and with or without casters.

Arm cap styles depend on the arm adjustment selected.

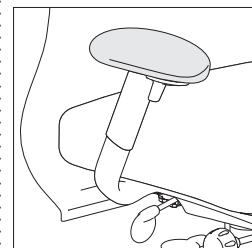

Arm cap on height-, width-, and pivot-adjustable arms.

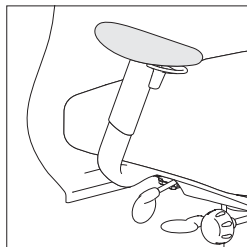

Arm cap on fixed and height and maintenance-width-adjustable arms.

Stackability for the Jersey guest chair is four high on the floor. Models with arms are 24 $\frac{1}{4}$ "W x 28 $\frac{1}{2}$ "D x 42 $\frac{1}{2}$ "H. Models without arms are 20 $\frac{5}{8}$ "W x 28 $\frac{1}{2}$ "D x 42 $\frac{1}{2}$ "H. If stacking dimensions are intended for an enclosure, add 2" to the width and depth, and 1" to the height for clearance.

Adjustment Features

Seat Adjustments

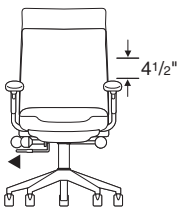

Seat height adjusts pneumatically.

To raise chair, lift body weight up, and pull lever up. To lower chair, remain seated and pull lever up.



Seat angle adjustment.

Pull lever back and hold, shift seat to desired angle, and release lever to lock.

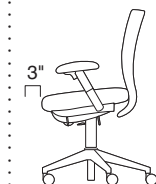

Seat depth adjustment.

Pull lever forward and hold, shift seat forward or back, and release lever to lock.

Back Adjustments

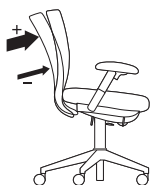

Back tension adjustment.

To decrease tension, turn counterclockwise. To increase tension, turn clockwise.



Upright back lock.

To release, lean forward and pull toward back. To lock, lean forward and push toward front.

Arm Adjustments

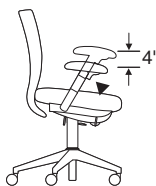

Arm height.

Pull trigger up and hold, pull arm up or push down, and release trigger to lock.

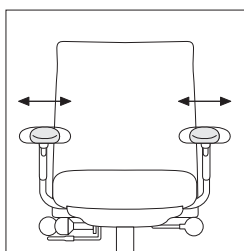

Arm width on rounded telescoping height, width, and pivot arm.

Grasp arm caps and move in or out. Arm will stay where positioned.

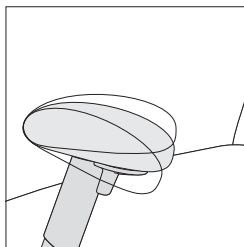

Arms pivot independently, 30° inward and outward.

Grasp arm and push from front to left or right.

Maintenance arm width adjustment.

Loosen and remove screws, slide arm bracket in. Replace and tighten screws.

Surface Materials

▶ See surface materials on page 432 for specific availability or refer to the *Surface Materials Reference Manual* for further information.

Upholstery

- Fabric or leather on seat
- Mesh on back standard

Hard components

- (base, arms, plastic arm caps, outer seat)
- Black

Platinum frame

(base and arm uprights) available as an option

Arms

- Black

All Steelcase seating with standard upholstery fabrics

complies with requirements of the State of California Technical Bulletin 117-2013. All standard seating is labeled to be in compliance with California 117-2013.

Programs & Services

▶ See the *Surface Materials Reference Manual* for further detail about programs and services offered for seating.

The Customer's Own Material (COM) Program

offers the opportunity for customers to select fabrics that are not offered through the standard Steelcase surface materials program for use on Steelcase products. Through the COM program, Steelcase will test your materials for application on Steelcase products. Once approved, you can place your order. Steelcase will facilitate the entire ordering process and give you a production schedule. Steelcase will order the COM fabric directly from the textile manufacturer. For up-to-date information regarding fabric test results for all COM fabrics and details regarding yardage requirements for most Seating lines, visit the COM website. To locate the COM website:

- Visit www.steelcase.com

Dimensions

▶ Page 172

Resources

Printed Materials

▶ Jersey Brochure (03-0000684)

Audiovisual Materials

▶ Jersey user Guide available on www.steelcase.com

Online Resources

▶ Environmental profiles available on www.steelcase.com/sustainability

Shipping

Jersey chairs are cartoned assembled only. Uncartoned shipments are not available.

Dimensions

Jersey Series

Features	Overall Depth	Width	Height	Functional Seat Depth	Seat Width	Seat Height from Floor	Back Width	Back Height from Seat
Jersey Series								
Work Chairs								
Pneumatic	25"	26 1/4"	35 1/2"–40"	17"*	20"	16"–20 1/2"	20"	18"
Multi-Use Chairs								
4-Leg with Arms	24"	24"	34"	17"	17 1/2"	17 1/2"	19"	15 1/2"
4-Leg Armless	24"	17 1/2"	34"	17"	17 1/2"	17 1/2"	19"	15 1/2"

*Models with seat depth measures 16 3/4"–20".

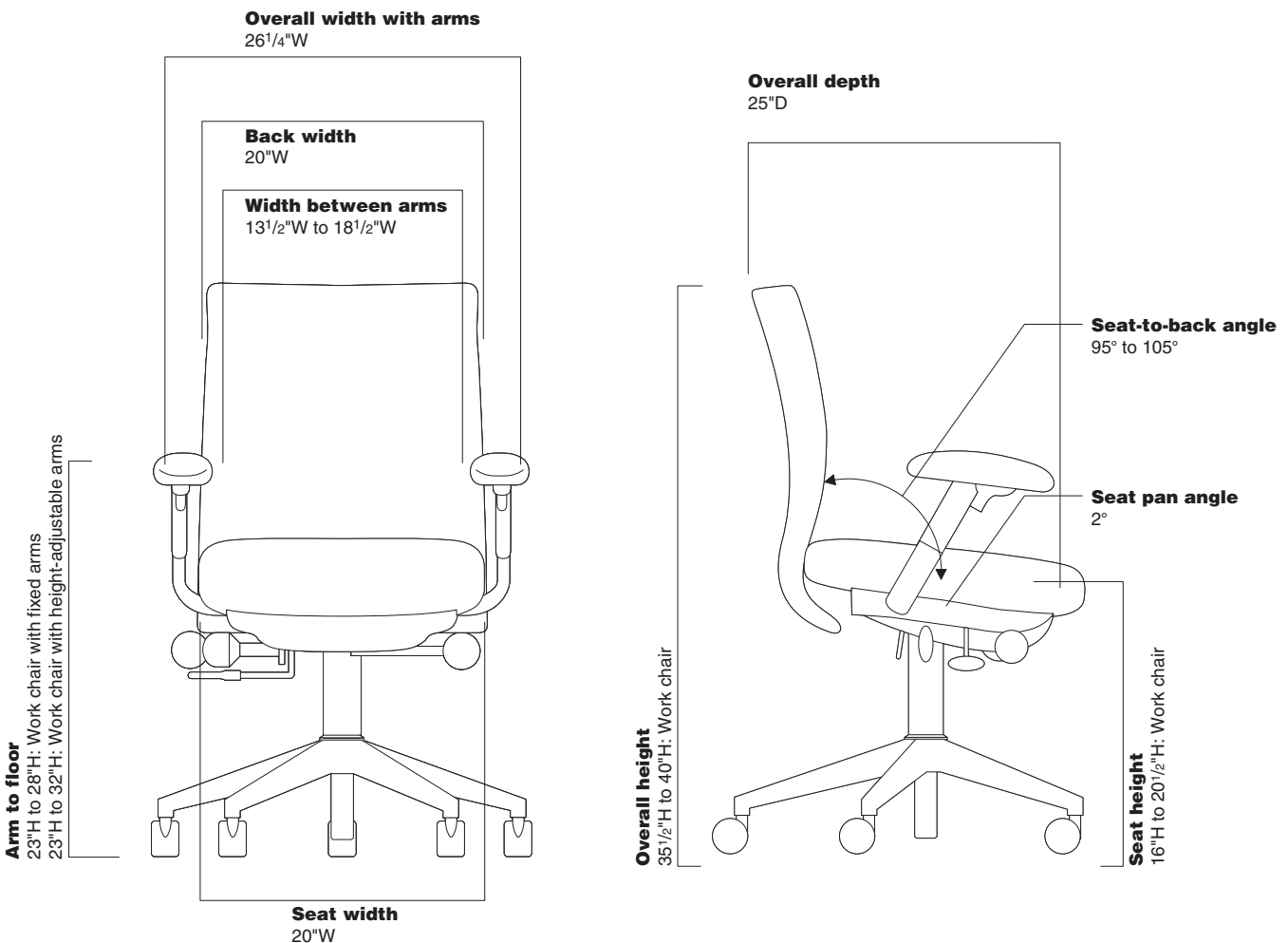

• Width • Between • Arms	• Arm to • Floor • Fixed • Arm	• Arm to • Floor • Height Adj • Arm	• Arm • Height • from Seat • Fixed Arm	• Arm • Height • from Seat • Adj-Height • Arm	• Seat • Pan • Angle	• Angle • Between • Seat and • Back
--------------------------------	---	--	---	---	----------------------------	--

Work Chairs

13½"-18½"	23"-28"	23"-32"	9"	7"-11"	2°	95°-105°
-----------	---------	---------	----	--------	----	----------

Multi-Use Chairs

21⅝"	25½"	N. A.	7½"	N. A.	2°	N. A.
N. A.	N. A.	N. A.	N. A.	N. A.	N. A.	N. A.
:	:	:	:	:	:	:

Jersey Series Value Package Work Chair

Black Mesh on Back with Buzz2 Fabric on Seat

Black Plastic Finish on Frame

SIN 711.18



Tip: This value package allows you to obtain the preselected features at a lower price than if specifying as a standard model number.

Tip: Options or substitutions are not available on this value package.

Standard Includes	Required to Specify
-------------------	---------------------

- | | | |
|--|--|--|
| <ul style="list-style-type: none"> ▶ Need help? Product details, page 170 | <ul style="list-style-type: none"> • Deluxe synchro-tilt mechanism: provides seat depth and seat angle • Pneumatic seat-height adjustment • Upright back lock • Tilt tension • Back: T084 Black mesh • Seat: Buzz2 fabric • Height-, width-, and pivot-adjustable arms • Frame: black plastic • 2½" diameter, hard composition, dual-wheel casters: black | <ul style="list-style-type: none"> 1 Style number 2 Buzz2 fabric color number ▶ See <i>Surface Materials</i>, page 432. |
|--|--|--|

Specification Information

• Style Number	• Price
JERSEYV	\$1078
•	•
•	•

▶ Detailed dimensions, page 172

Jersey Series Work Chair

SIN 711.18



Standard Includes	Required to Specify
<ul style="list-style-type: none"> ▶ Need help? Product details, page 170 • Synchro-tilt mechanism • Pneumatic height adjustment • Upright back lock • Tilt tension • Back: mesh • Seat: fabric • Five-arm base: reinforced black plastic • 2½" diameter, hard composition, dual-wheel casters: black 	<ul style="list-style-type: none"> 1 Style number 2 Mesh color number for back 3 Fabric number for seat 4 Options, if selected (see below) ▶ See <i>Surface Materials</i>, page 432.

Tip: Leather, Elmosoft leather, COL, vinyl, and COM vinyls materials require an **S** suffix.

Options	Price	Required to Specify
<p>Surface Materials</p> <ul style="list-style-type: none"> • Jersey black fabric • Fabric price group 1 • Fabric price group 2 • Fabric price group 3 • Fabric price group 4 • Fabric price group 5 • Fabric price group 6 • Fabric price group 7 • Fabric price group 8 • Fabric price group 9 • Fabric price group 10 • Jersey black leather • Steelcase leather upholstery • Select Surfaces leather price group 1 • Elmosoft leather upholstery • Select Surfaces leather price group 2 • Steelcase vinyl • Customer's Own Material (COM) • Customer's Own Leather (COL) • Customer's Own Material/Vinyl (COM-Sewn) 	<ul style="list-style-type: none"> No cost No cost +\$ 10 +\$ 26 +\$ 35 +\$ 42 +\$ 51 +\$ 62 +\$ 77 +\$ 94 +\$109 +\$ 99 +\$171 +\$171 +\$197 +\$197 +\$ 10 No cost No cost No cost 	<p>Specify with 5011.</p> <p>Specify fabric color number.</p> <p>Specify fabric color number.</p> <p>Specify fabric color number.</p> <p>Specify fabric color number.</p> <p>Specify fabric color number.</p> <p>Specify fabric color number.</p> <p>Specify fabric color number.</p> <p>Specify fabric color number.</p> <p>Specify fabric color number.</p> <p>Specify fabric color number.</p> <p>Specify fabric color number.</p> <p>Add suffix S to the style number and specify with L225.</p> <p>Add suffix S to the style number and specify leather color number.</p> <p>Add suffix S to the style number and specify Select Surfaces leather price group 1.</p> <p>▶ See <i>Surface Materials Reference Manual</i>. Add suffix S to the style number and specify Elmosoft leather color number.</p> <p>Add suffix S to the style number and specify Select Surfaces leather price group 2.</p> <p>▶ See <i>Surface Materials Reference Manual</i>. Add suffix S to the style number and specify vinyl color number.</p> <p>▶ See <i>Surface Materials Reference Manual</i>. Add suffix S to the style number and specify leather color number.</p> <p>Add suffix S to the style number and specify vinyl color number.</p>
<p>Frame and Base</p> <ul style="list-style-type: none"> • 4799 Platinum frame with aluminum base 	<ul style="list-style-type: none"> +\$ 86 	<p>Specify with 4799 Platinum.</p>
<p>Seating Mechanism</p> <ul style="list-style-type: none"> • Deluxe synchro-tilt mechanism: provides seat depth and seat angle 	<ul style="list-style-type: none"> +\$ 93 	<p>Specify with deluxe synchro-tilt mechanism.</p>
<p>Fixed-Height Arms</p> <ul style="list-style-type: none"> • Fixed-height, maintenance width-adjustable arms 	<ul style="list-style-type: none"> +\$104 	<p>Specify with fixed-height, maintenance width-adjustable arms.</p>
<p>Height-Adjustable Arms</p> <ul style="list-style-type: none"> • Height- and maintenance width-adjustable arms 	<ul style="list-style-type: none"> +\$128 	<p>Specify with height- and maintenance width-adjustable arms.</p>
<p>Height-, Width-, and Pivot-Adjustable Arms</p> <ul style="list-style-type: none"> • Height-, width-, and pivot-adjustable arms 	<ul style="list-style-type: none"> +\$151 	<p>Specify with height-, width-, and pivot-adjustable arms.</p>
<p>Casters</p> <ul style="list-style-type: none"> • Soft, dark grey treaded, dual-wheel roll-control casters for use on hard floors 	<ul style="list-style-type: none"> +\$ 25 	<p>Specify with soft roll-control casters.</p>

Tip: Arms, if specified, will match frame color (7207 Black standard, 4799 Platinum optional).

▶ Detailed dimensions, page 172

SIN 711.18

Specification Information

Style Number	Base Price
TS38301	\$900



Jersey Series

Jersey Series Multi-Use Chairs

SIN 711.18

Multi-Use Chair, Fabric, with Glides



Tip: Arms, if specified, will match frame color (7207 Black standard, 4799 Platinum optional).

Tip: Leather, Elmosoft leather, COL, vinyl, and COM vinyl materials require an **S** suffix.

Standard Includes	Required to Specify
<ul style="list-style-type: none"> ▶ Need help? Product details, page 170 • Back: mesh • Seat: fabric • Arms, if selected: black • Steel four-leg frame: black • Glides: black plastic • Stacks four high 	<ul style="list-style-type: none"> 1 Style number 2 Mesh color number for back 3 Fabric number for seat 4 Options, if selected (see below) ▶ See <i>Surface Materials</i>, page 432.

Options	Price	Required to Specify
Surface Materials <ul style="list-style-type: none"> • Jersey black fabric • Fabric price group 1 • Fabric price group 2 • Fabric price group 3 • Fabric price group 4 • Fabric price group 5 • Fabric price group 6 • Fabric price group 7 • Fabric price group 8 • Fabric price group 9 • Fabric price group 10 • Jersey black leather • Steelcase leather upholstery • Select Surfaces leather price group 1 • Elmosoft leather upholstery • Select Surfaces leather price group 2 • Steelcase vinyl • Customer's Own Material (COM) • Customer's Own Leather (COL) • Customer's Own Material/Vinyl (COM-Sewn) 	<ul style="list-style-type: none"> No cost No cost +\$ 10 +\$ 26 +\$ 35 +\$ 42 +\$ 51 +\$ 62 +\$ 77 +\$ 94 +\$109 +\$ 99 +\$171 +\$171 +\$197 +\$197 +\$ 10 No cost No cost No cost 	<ul style="list-style-type: none"> Specify with 5011. Specify fabric color number. Specify fabric color number. Specify fabric color number. Specify fabric color number. Specify fabric color number. Specify fabric color number. Specify fabric color number. Specify fabric color number. Specify fabric color number. Specify fabric color number. Specify fabric color number. Add suffix S to the style number and specify with L225. Add suffix S to the style number and specify leather color number. Add suffix S to the style number and specify Select Surfaces leather price group 1. ▶ See <i>Surface Materials Reference Manual</i>. Add suffix S to the style number and specify Elmosoft leather color number. Add suffix S to the style number and specify Select Surfaces leather price group 2. ▶ See <i>Surface Materials Reference Manual</i>. Add suffix S to the style number and specify vinyl color number. ▶ See <i>Surface Materials Reference Manual</i>. Add suffix S to the style number and specify leather color number. Add suffix S to the style number and specify vinyl color number.
Frame <ul style="list-style-type: none"> • 4799 Platinum aluminum frame 	<ul style="list-style-type: none"> +\$ 57 	<ul style="list-style-type: none"> Specify with 4799 Platinum.

▶ Detailed dimensions, page 172

Specification Information

• Style • Number	• Base • Price
---------------------	-------------------

With Arms

TS38304	\$557
---------	-------



Without Arms

TS38305	\$511
---------	-------



Jersey Series Multi-Use Chairs, continued

SIN 711.18

Multi-Use Chair, Fabric, with Casters

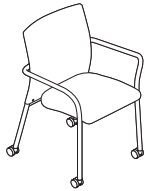

Tip: Arms, if specified, will match frame color (7207 Black standard, 4799 Platinum optional).

Tip: Leather, Elmosoft leather, COL, vinyl, and COM vinyl materials require a **S** suffix.

Standard Includes		Required to Specify
<ul style="list-style-type: none"> ▶ Need help? Product details, page 170 	<ul style="list-style-type: none"> • Back: mesh • Seat: fabric • Arms, if selected: black • Steel four-leg frame: black • 2½" diameter, hard composition, dual-wheel casters: black 	<ol style="list-style-type: none"> 1 Style number 2 Mesh color number for back 3 Fabric number for seat 4 Options, if selected (see below) <ul style="list-style-type: none"> ▶ See <i>Surface Materials</i>, page 432.

Options	Price	Required to Specify
Surface Materials		
Seat Upholstery		Specify <i>with 5011</i> .
• Jersey black fabric	No cost	Specify fabric color number.
• Fabric price group 1	No cost	Specify fabric color number.
• Fabric price group 2	+\$ 10	Specify fabric color number.
• Fabric price group 3	+\$ 26	Specify fabric color number.
• Fabric price group 4	+\$ 35	Specify fabric color number.
• Fabric price group 5	+\$ 42	Specify fabric color number.
• Fabric price group 6	+\$ 51	Specify fabric color number.
• Fabric price group 7	+\$ 62	Specify fabric color number.
• Fabric price group 8	+\$ 77	Specify fabric color number.
• Fabric price group 9	+\$ 94	Specify fabric color number.
• Fabric price group 10	+\$109	Specify fabric color number.
• Jersey black leather	+\$ 99	Specify fabric color number.
• Steelcase leather upholstery	+\$171	Add suffix S to the style number and specify <i>with L225</i> .
• Select Surfaces leather price group 1	+\$171	Add suffix S to the style number and specify leather color number.
• Elmosoft leather upholstery	+\$197	Add suffix S to the style number and specify Select Surfaces leather price group 1.
• Select Surfaces leather price group 2	+\$197	▶ See <i>Surface Materials Reference Manual</i> . Add suffix S to the style number and specify Elmosoft leather color number.
• Steelcase vinyl	+\$ 10	Add suffix S to the style number and specify Select Surfaces leather price group 2.
• Customer's Own Material (COM)	No cost	▶ See <i>Surface Materials Reference Manual</i> . Add suffix S to the style number and specify vinyl color number.
• Customer's Own Leather (COL)	No cost	▶ See <i>Surface Materials Reference Manual</i> . Add suffix S to the style number and specify leather color number.
• Customer's Own Material/Vinyl (COM-Sewn)	No cost	Add suffix S to the style number and specify vinyl color number.
Frame		
• 4799 Platinum aluminum frame	+\$ 57	Specify <i>with 4799 Platinum</i> .
Casters		
• Soft dual-wheel casters for use on hard floors	+\$ 25	Specify <i>with soft casters</i> .

▶ Detailed dimensions, page 172

Specification Information

•Style •Number	•Base •Price
-------------------	-----------------

With Arms

TS38308	\$609
---------	-------

Without Arms

TS38309	\$567
---------	-------

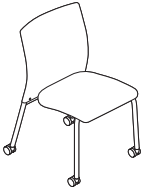
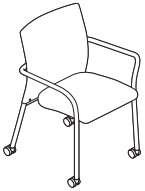

Protégé 433 Series

Protégé is an economic, general-use solution with basic ergonomic features. Protégé is stylish, comfortable, and well suited for a wide range of tasks, including moderate computer use.

Outer back is plastic. Fully upholstered outer back is an option.

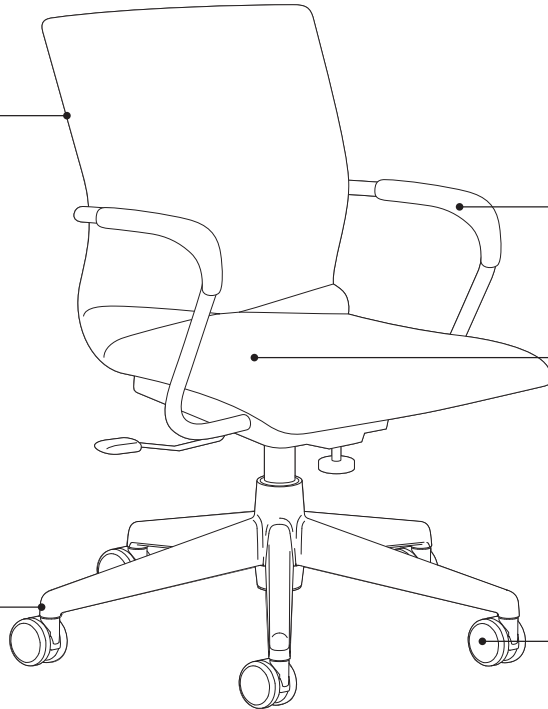

Arms are available with soft arm caps.

Seat height adjusts with a 5" range from 15"H to 20"H with a pneumatic adjustment mechanism.

Five-arm base is standard.

Casters have hard, dual-wheel that roll smoothly on carpets. They are 2½" diameter for increased mobility. Soft, dark grey treaded, dual-wheel roll control casters are available as an option for use on hard floors and chair mats.
Tip: Do not roll the chair across asphalt during installation as this may damage the casters.

Product Details



Work and multi-use chairs are available with or without arms.



Multi-use chair bases are available in two styles: advanced swivel tilt and sled base.

Adjustment Features

Seat Adjustments

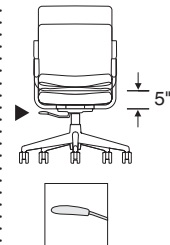

Seat height adjusts pneumatically. To lower, hold handle up while seated. To raise, hold handle up and keep your weight off the chair.

Back Adjustments



Back tension adjusts by turning knob. Turn knob clockwise to increase tension, counterclockwise to decrease.

Adjustability Features

Protégé

Mechanisms

Advanced swivel-tilt ●

Seat Adjustments

Pneumatic height ●

Back Adjustments

Upright back lock ●

Back tension ●



Upright back lock.
Flick switch forward to lock; flick switch back to tilt.

Surface Materials

▶ See surface materials on page 432 for specific availability or refer to the *Surface Materials Reference Manual* for further information.

Upholstery

- Fabric
- Fabric with soil-retardant treatment (option)
- Leather
- Elmosoft leather
- Select Surfaces leather
- Vinyl

Base and Arms

- 6205 Black
- 6250 Coffee
- 6249 Platinum

Arm Caps and Outer Back Shell

- 6205 Black
- 6250 Coffee

Casters

- 6205 Black

Tip: Chairs with platinum finish will feature a platinum base and arms, and a black outer shell, casters, and arm caps (if specified).

Glides

- Plastic on sled base models

All Steelcase seating with standard upholstery fabrics

complies with requirements of the State of California Technical Bulletin 117-2013. All standard seating is labeled to be in compliance with California 117-2013.

Programs & Services

▶ See the *Surface Materials Reference Manual* for further detail about programs and services offered for seating.

The Customer's Own Material (COM) Program

offers the opportunity for customers to select fabrics that are not offered through the standard Steelcase surface materials program for use on Steelcase products. Through the COM program, Steelcase will test your materials for application on Steelcase products. Once approved, you can place your order. Steelcase will facilitate the entire ordering process and give you a production schedule. Steelcase will order the COM fabric directly from the textile manufacturer. For up-to-date information regarding fabric test results for all COM fabrics and details regarding yardage requirements for most Seating lines, visit the COM website. To locate the COM website:

- Visit www.steelcase.com

Soil retardants are treatments that provide long-term soil and stain resistance to a fabric without affecting the shade or the integrity of the fabric. The following Steelcase Textiles are available pre-treated with soil retardant. (You do not need to select the soil-retardant option for these fabrics and incur the upcharge.)

- Jacks
- Link
- Spyder

For information on soil retardant fabrics on Select Surfaces, please refer to the *Surface Materials Reference Manual*.

Soil-retardant treatment is available on all other seating fabrics at an additional upcharge. To order this option, please select "Soil-Retardant Treatment" under "Optional Accessories."

For soil-retardant treatment on COMs, please select "Soil-Retardant Treatment" under "Optional Accessories." Minimums or additional yardage may be required. Please contact the vendor directly for specific information.

Extended lead times may be necessary for this service.

Contact your Steelcase Solutions Fulfillment Team Representative or contact Line 1 at 1.888.STEELCASE (1.888.783.3522) or send an email to lineone@steelcase.com.

Dimensions

▶ Page 184

Resources

Printed Materials

▶ Protégé Seating Brochure (08-0000160)

Online Resources

▶ Environmental profiles available on www.steelcase.com/sustainability

Dimensions

Protégé 433 Series

Features	Overall Depth	Width	Height	Seat Depth	Functional Seat Depth	Seat Width	Seat Height from Floor	Back Width	Back Height from Seat
----------	---------------	-------	--------	------------	-----------------------	------------	------------------------	------------	-----------------------

Protégé 433 Series

Work Chairs

Pneumatic	21 1/4"	24 1/4"	32 3/4"–37 3/4"	17 1/2"	16"	19 1/2"	15"–20"	19"	19 1/4"
-----------	---------	---------	-----------------	---------	-----	---------	---------	-----	---------

Multi-Use Chairs

Fixed Height	21 1/4"	24 1/4"	35 1/4"	17 1/2"	16"	19 1/2"	17 1/4"	19"	19 1/4"
--------------	---------	---------	---------	---------	-----	---------	---------	-----	---------

Sled Base	21 1/4"	23"	35"	17 1/2"	16"	19 1/2"	18 1/4"	19"	19 1/4"
-----------	---------	-----	-----	---------	-----	---------	---------	-----	---------

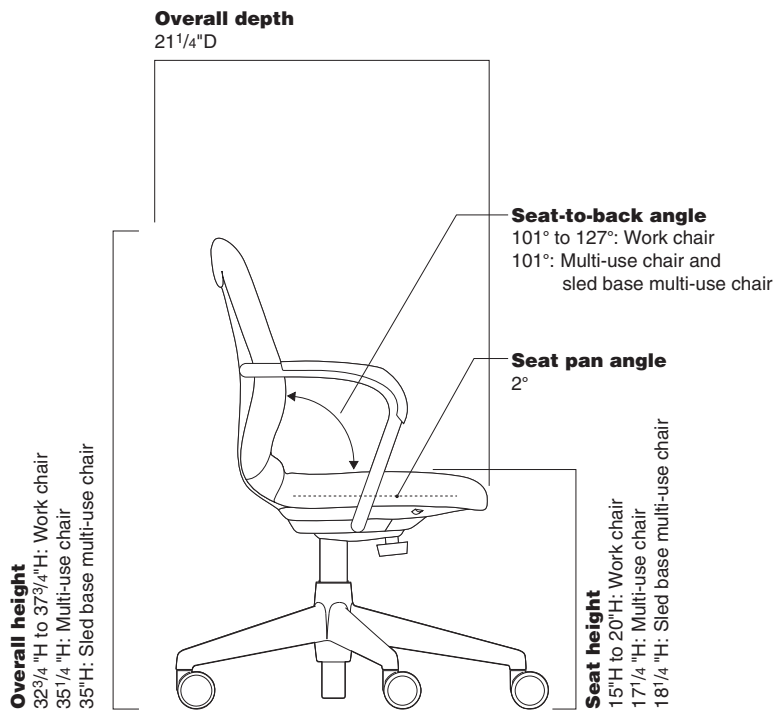
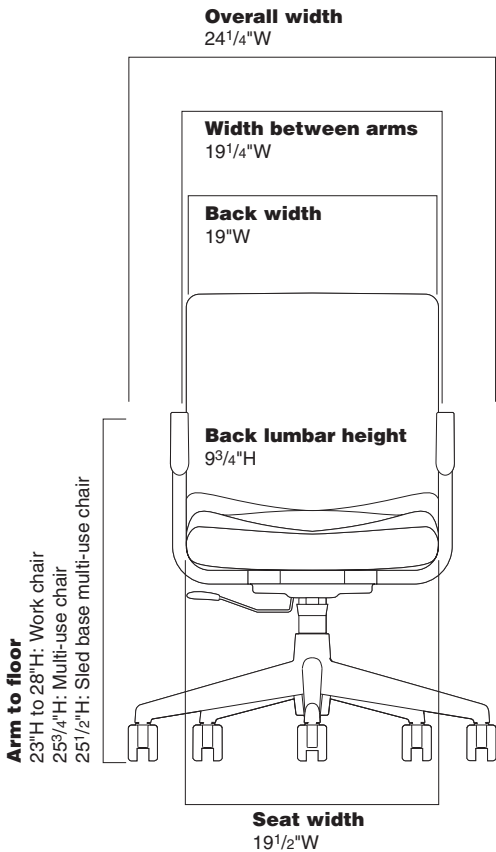

• Back Lumbar Height	• Width Between Arms	• Arm to Floor	• Arm Height from Seat	• Seat Pan Angle	• Angle Between Seat and Back
----------------------	----------------------	----------------	------------------------	------------------	-------------------------------

Work Chairs

9¾"	19¼"	23"-28"	7¾"	2°	101°-127°
-----	------	---------	-----	----	-----------

Multi-Use Chairs

9¾"	19¼"	25¾"	7¾"	2°	101°
-----	------	------	-----	----	------

9¾"	19¼"	25½"	7¾"	2°	101°
-----	------	------	-----	----	------

:	:	:	:	:	:
---	---	---	---	---	---

Protégé 433 Series Value Package Work Chair

Buzz2 Fabric on Seat and Back

Black Plastic Finish on Frame

SIN 711.18



Tip: This value package allows you to obtain the preselected features at a lower price than if specifying as a standard model number.

Tip: Options or substitutions are not available on this value package.

Standard Includes	Required to Specify
-------------------	---------------------

▶ Need help?
Product details,
page 182

- Advanced swivel-tilt mechanism
- Pneumatic seat-height adjustment
- Arms with soft arm caps: black plastic
- Back tension adjustment
- Seat and back: Buzz2 fabric
- Five-arm base: black plastic
- Frame: black plastic
- 2½"-diameter, hard composition, dual-wheel casters: black plastic

- 1 Style number
- 2 Buzz2 fabric color number
- ▶ See *Surface Materials*, page 432.

Specification Information	
• Style Number	• Price

• Style Number	• Price
:	:
:	:
:	:
PROTEGEV	\$783
:	:

▶ Detailed dimensions,
page 184

SIN 711.18

Protégé 433 Series Work Chairs

SIN 711.18



Tip: Leather and vinyl upcharges are in addition to sewn upholstery upcharge.

Tip: To get leather on a fully upholstered chair, you will need to add both the fully upholstered with leather upcharge and the upcharge for the leather itself.

Tip: Chairs with a platinum finish will feature a platinum base and arms, and a black outer shell, casters, and arm caps (if specified).

► Detailed dimensions, page 184

Standard Includes		Required to Specify
► Need help? Product details, page 182	<ul style="list-style-type: none"> Advanced swivel-tilt mechanism Arms with soft plastic arm caps, if selected: color to match base Back tension adjustment Upholstery: fabric price group 1 Five-arm base: plastic color 2½"-diameter, hard composition, dual-wheel casters: black plastic 	<ol style="list-style-type: none"> Style number Plastic color number for base and arms Fabric color number for upholstery Options, if selected (see below) <p>► See <i>Surface Materials</i>, page 432.</p>

Options	Price	Required to Specify
Surface Materials		
Upholstery		
• Fabric price group 1	No cost	Specify fabric color number.
• Fabric price group 2	+\$ 26	Specify fabric color number.
• Fabric price group 3	+\$ 48	Specify fabric color number.
• Fabric price group 4	+\$ 68	Specify fabric color number.
• Fabric price group 5	+\$ 85	Specify fabric color number.
• Fabric price group 6	+\$121	Specify fabric color number.
• Fabric price group 7	+\$171	Specify fabric color number.
• Fabric price group 8	+\$226	Specify fabric color number.
• Fabric price group 9	+\$268	Specify fabric color number.
• Fabric price group 10	+\$312	Specify fabric color number.
• Steelcase leather upholstery	+\$645	Add suffix S to style number and specify leather color number.
• Select Surfaces leather price group 1	+\$645	Add suffix S to the style number and specify Select Surfaces leather price group 1.
		► See <i>Surface Materials Reference Manual</i> .
• Elmosoft leather upholstery	+\$756	Add suffix S to the style number and specify Elmosoft leather color number.
• Select Surfaces leather price group 2	+\$756	Add suffix S to the style number and specify Select Surfaces leather price group 2.
		► See <i>Surface Materials Reference Manual</i> .
• Steelcase vinyl	+\$ 26	Add suffix S to style number and specify vinyl color number.
		► See <i>Surface Materials Reference Manual</i> to specify.
• Customer's Own Material (COM)	+\$ 37	Add suffix S to style number.
• Customer's Own Leather (COL)	+\$364	► See <i>Surface Materials Reference Manual</i> to specify.
Soil-retardant treatment	+\$ 25	Specify with <i>soil-retardant treatment</i> .
Sewn upholstery		
• Sewn upholstery on chair	+\$ 77	Add suffix S to the style number.
Fully upholstered		
• Fully upholstered with fabric	+\$125	Add suffix U to style number.
• Fully upholstered with leather	+\$688	Add suffix SU to style number.
• Steelcase leather fully upholstered outer back and outer seat	+\$561	Add suffix SU to style number and specify leather color number.
• Select Surfaces leather price group 1 fully upholstered outer back and outer seat	+\$561	Add suffix SU to the style number and specify Select Surfaces leather price group 1.
		► See <i>Surface Materials Reference Manual</i>
• Elmosoft leather upholstery	+\$753	Add suffix SU to the style number and specify Elmosoft leather color number.
• Select Surfaces leather price group 2 fully upholstered outer back and outer seat	+\$753	Add suffix SU to the style number and specify Select Surfaces leather price group 2.
		► See <i>Surface Materials Reference Manual</i>
• Customer's Own Leather (COL) fully upholstered outer back and outer seat	No cost	Add suffix SU to style number.
		► See <i>Surface Materials Reference Manual</i> to specify.
Platinum		
• On base and arms	+\$ 86	Specify with <i>6249 Platinum</i> .

► Options, continued on next page

► Options, continued from previous page

Options	Price	Required to Specify
Casters <ul style="list-style-type: none"> Soft, dark grey treaded, dual-wheel roll-control casters for use on hard floors 	+\$25	Specify with soft roll-control casters.

Specification Information

Arms with Soft Arm Caps



• Style Number
• Base Price

Without Arms



• Style Number
• Base Price

Work Chairs

Pneumatic

4331223	\$868	4331203	\$785
----------------	-------	----------------	-------

Pneumatic with Upright Back Lock

4331423	\$927	4331403	\$844
----------------	-------	----------------	-------

Protégé 433 Series Multi-Use Chairs

SIN 711.18



► Need help?
Product details,
page 182

Standard Includes

- Fixed height with advanced swivel-tilt mechanism
- Arms with soft plastic arm caps, if selected: color to match base
- Back tension adjustment
- Upholstery: fabric price group 1
- Five-arm base: plastic color
- 2½"-diameter, hard composition, dual-wheel casters: black plastic

Required to Specify

- 1 Style number
 - 2 Plastic color number for base and arms
 - 3 Fabric color number for upholstery
 - 4 Options, if selected (see below)
- See *Surface Materials*, page 432.

Tip: Leather and vinyl upcharges are in addition to sewn upholstery upcharge.

	Options	Price	Required to Specify
Surface Materials	Upholstery		
	• Fabric price group 1	No cost	Specify fabric color number.
	• Fabric price group 2	+\$ 26	Specify fabric color number.
	• Fabric price group 3	+\$ 48	Specify fabric color number.
	• Fabric price group 4	+\$ 68	Specify fabric color number.
	• Fabric price group 5	+\$ 85	Specify fabric color number.
	• Fabric price group 6	+\$121	Specify fabric color number.
	• Fabric price group 7	+\$171	Specify fabric color number.
	• Fabric price group 8	+\$226	Specify fabric color number.
	• Fabric price group 9	+\$268	Specify fabric color number.
	• Fabric price group 10	+\$312	Specify fabric color number.
	• Steelcase leather upholstery	+\$645	Add suffix S to style number and specify leather color number.
	• Select Surfaces leather price group 1	+\$645	Add suffix S to the style number and specify Select Surfaces leather price group 1. ► See <i>Surface Materials Reference Manual</i> .
• Elmosoft leather upholstery	+\$756	Add suffix S to the style number and specify Elmosoft leather color number.	
• Select Surfaces leather price group 2	+\$756	Add suffix S to the style number and specify Select Surfaces leather price group 2. ► See <i>Surface Materials Reference Manual</i> .	
• Steelcase vinyl	+\$ 26	Add suffix S to style number and specify vinyl color number. ► See <i>Surface Materials Reference Manual</i> to specify.	
• Customer's Own Material (COM)	+\$ 37	Add suffix S to style number.	
• Customer's Own Leather (COL)	+\$364	► See <i>Surface Materials Reference Manual</i> to specify.	
	Soil-retardant treatment	+\$ 25	Specify with <i>soil-retardant treatment</i> .
	Sewn upholstery		
	• Sewn upholstery on chair	+\$ 77	Add suffix S to the style number.
	Fully upholstered		
	• Fully upholstered with fabric	+\$125	Add suffix U to style number.
	• Fully upholstered with leather	+\$688	Add suffix SU to style number.
	• Steelcase leather fully upholstered outer back and outer seat	+\$561	Add suffix SU to style number and specify leather color number.
	• Select Surfaces leather price group 1 fully upholstered outer back and outer seat	+\$561	Add suffix SU to the style number and specify Select Surfaces leather price group 1. ► See <i>Surface Materials Reference Manual</i> .
	• Elmosoft leather upholstery	+\$753	Add suffix SU to the style number and specify Elmosoft leather color number.
	• Select Surfaces leather price group 2 fully upholstered outer back and outer seat	+\$753	Add suffix SU to the style number and specify Select Surfaces leather price group 2. ► See <i>Surface Materials Reference Manual</i> .
	• Customer's Own Leather (COL) fully upholstered outer back and outer seat	No cost	Add suffix SU to style number. ► See <i>Surface Materials Reference Manual</i> to specify.
	Platinum		
	• On base and arms	+\$ 86	Specify with <i>6249 Platinum</i> .

Tip: To get leather on a fully upholstered chair, you will need to add both the fully upholstered with leather upcharge and the upcharge for the leather itself.

Tip: Chairs with a platinum finish will feature a platinum base and arms, and a black outer shell, casters, and arm caps (if specified).

► Detailed dimensions,
page 184

► Options, continued on next page

SIN 711.18

► Options, continued from previous page

Options	Price	Required to Specify
Casters <ul style="list-style-type: none"> Soft, dark grey treaded, dual-wheel roll-control casters for use on hard floors 	+\$25	Specify with soft roll-control casters.

Specification Information

Arms with Soft Arm Caps



Style Number	Base Price

Without Arms



Style Number	Base Price

Multi-Use Chairs

Fixed Height

4333023	\$843	4333003	\$760

Protégé 433 Series

Protégé 433 Series Sled-Base Multi-Use Chair

SIN 711.18



Tip: Leather and vinyl upcharges are in addition to sewn upholstery upcharge.

Tip: To get leather on a fully upholstered chair, you will need to add both the fully upholstered with leather upcharge and the upcharge for the leather itself.

Tip: Chairs with a platinum finish will feature a platinum base and arms, and a black outer shell and arm caps.

Standard Includes	Required to Specify
<ul style="list-style-type: none"> ▶ Need help? Product details, page 182 • Upholstery: fabric price group 1 • Frame: plastic color • Arms with soft arm caps • Glides: clear plastic 	<ol style="list-style-type: none"> 1 Style number 2 Plastic color number for base and arms 3 Fabric color number for upholstery 4 Options, if selected (see below) <ul style="list-style-type: none"> ▶ See <i>Surface Materials</i>, page 432.

Options	Price	Required to Specify
Surface Materials		
Upholstery		
• Fabric price group 1	No cost	Specify fabric color number.
• Fabric price group 2	+\$ 26	Specify fabric color number.
• Fabric price group 3	+\$ 48	Specify fabric color number.
• Fabric price group 4	+\$ 68	Specify fabric color number.
• Fabric price group 5	+\$ 85	Specify fabric color number.
• Fabric price group 6	+\$121	Specify fabric color number.
• Fabric price group 7	+\$171	Specify fabric color number.
• Fabric price group 8	+\$226	Specify fabric color number.
• Fabric price group 9	+\$268	Specify fabric color number.
• Fabric price group 10	+\$312	Specify fabric color number.
• Steelcase leather upholstery	+\$645	Specify fabric color number. Add suffix S to style number and specify leather color number.
• Elmosoft leather upholstery	+\$756	Add suffix S to the style number and specify Elmosoft leather color number.
• Steelcase vinyl	+\$ 26	Add suffix S to style number and specify vinyl color number.
• Customer's Own Material (COM)	+\$ 37	▶ See <i>Surface Materials Reference Manual</i> to specify.
• Customer's Own Leather (COL)	+\$364	Add suffix S to style number. ▶ See <i>Surface Materials Reference</i> to specify.
Soil-retardant treatment	+\$ 25	Specify with <i>soil-retardant treatment</i> .
Sewn upholstery		
• Sewn upholstery on chair	+\$ 77	Add suffix S to the style number.
Fully upholstered		
• Fully upholstered with fabric	+\$125	Add suffix U to style number.
• Fully upholstered with leather	+\$688	Add suffix SU to style number.
• Steelcase leather fully upholstered outer back and outer seat	+\$561	Add suffix SU to style number and specify leather color number.
• Select Surfaces leather price group 1 fully upholstered outer back and outer seat	+\$561	Add suffix SU to the style number and specify Select Surfaces leather price group 1.
• Elmosoft leather upholstery	+\$753	▶ See <i>Surface Materials Reference Manual</i> Add suffix SU to the style number and specify Elmosoft leather color number.
• Select Surfaces leather price group 2 fully upholstered outer back and outer seat	+\$753	Add suffix SU to the style number and specify Select Surfaces leather price group 2.
• Customer's Own Leather (COL) fully upholstered outer back and outer seat	No cost	Add suffix SU to style number. ▶ See <i>Surface Materials Reference Manual</i> to specify.
Platinum		
• On sled-base frame	+\$ 86	Specify with <i>6249 Platinum</i> .

Specification Information	
• Style Number	• Base Price
4335023	\$707

▶ Detailed dimensions, page 184

Cachet 487 Series

Cachet chairs are lightweight, extremely comfortable, multipurpose chairs with a unique Balanced-Action Rocker (BAR) mechanism that allows the chair to recline in response to the user's weight.

Flexible, contoured back and seat have parallel slats that conform to individual users.

Nylon injection-molded tubular frame provides strength with minimal weight.

Plastic glides are standard. Optional soft glides are available.

Balanced-action rocker (BAR) mechanism allows every user to fully recline.

Five-arm base is standard.

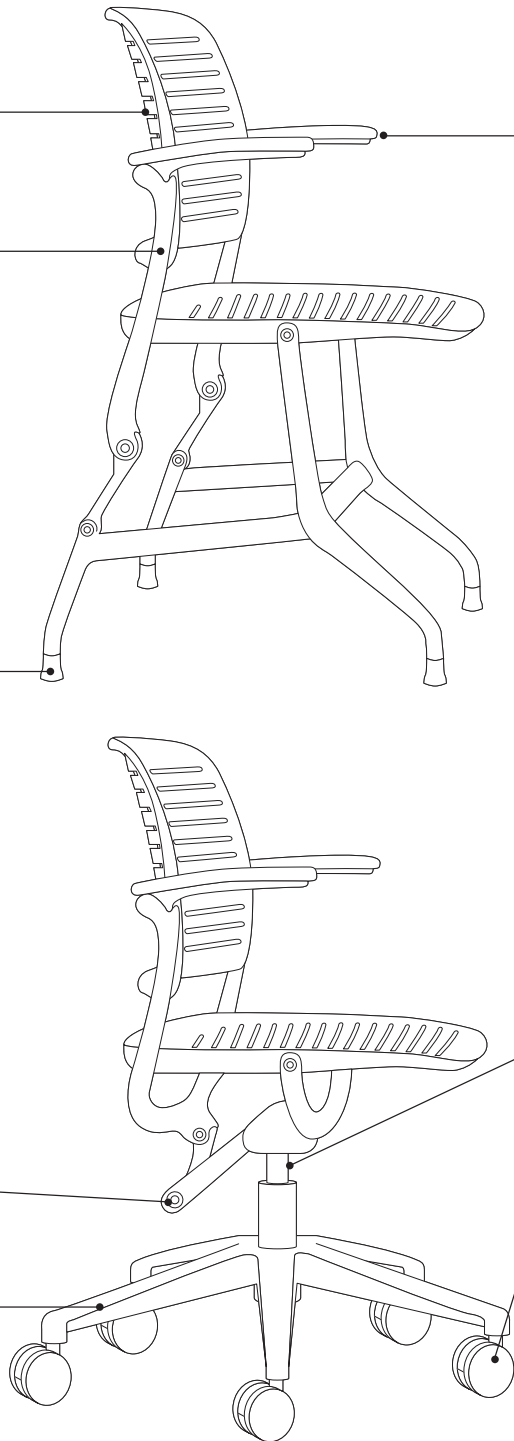

Flip-up arms easily lift to move out of the way or to allow for stacking.

Seat height adjusts within a 5" range (15½"H to 20½"H) with a pneumatic-adjustment mechanism.

Casters have hard, dual-wheels that roll smoothly on carpets. They are 2⅝" diameter for increased mobility. Soft dual-wheel roll control casters are available as an option for use on hard floors and chair mats.
Tip: Do not roll the chair across asphalt during installation as this may damage the casters.

Product Details



Chair bases are available in three styles—fixed-height four leg, adjustable-height swivel, and adjustable-height stool.



Balanced-action rocker (BAR) mechanism allows the user to recline for optimum comfort.



Upholstered cushions

are available for use on chair back and seat. Cushions can be specified for factory installation or ordered separately for field installation. When specified with the chair, cushions are available for seat and back, or seat only. When ordered separately, cushions are available for seat and back, seat only, or back only. The cushions attach to the slats of back and seat.

Tip: You must specify plastic outer back color to match chair.

Soft dual-wheel roll-control casters

are available as an option for use on hard floors or chair mats. Roll-control casters feature an internal brake that activates when the chair is not under load to reduce shifting when user stands up.

Hard plastic glides

are standard on leg-base chairs.

Soft felt glides are available as an option for use on non-carpeted surfaces. The soft glide is reversible—soft on one side, hard on the other.

Leg-base chairs stack five high on the floor and 20 high on the dolly. Upholstery does not impact stacking capacity.

Leg-base chairs are available with or without flip-up arms. Chairs with or without arms can be stacked.

Other Features

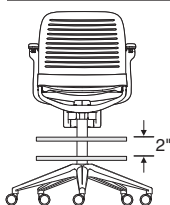

Foot ring height on stools adjusts by first lifting ring and rotating it counter-clockwise to unlock. Then raise or lower ring up to 2" to desired position before rotating it clockwise to lock. The foot ring has a diameter of 20".

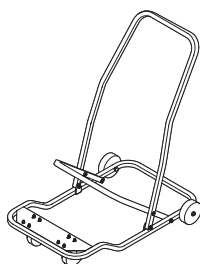

Transport and storage dolly is available to stack, move, and store up to 20 leg-base chairs. Upholstery does not impact stacking capacity. Swivel-base chairs will not stack.

Unloaded transport dolly measures 48"D x 23"W x 38¾"H.

Fully loaded transport dolly measures 51"D x 23"W x 78¾"H.

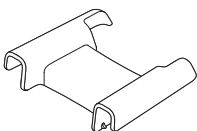

Ganging and alignment device is available to link leg-base chairs together in the field for evenly spaced rows. Chairs can be separated easily. Spacing between chairs linked with alignment device is 2".
Tip: You must specify plastic color of ganging and alignment device to match chairs.

Cachet is recommended for indoor use only.

Surface Materials

▶ See surface materials on page 432 for specific availability or refer to the *Surface Materials Reference Manual* for further information.

Hard components

(frame, flip-up arms, back, seat, and base)

- Swivel and 4-leg chair models available in black, midnight, and ash
- Stool available in black only

Upholstery

- Fabric
- Fabric with soil-retardant treatment (option)
- Leather
- Elmosoft leather
- Select Surfaces leather
- Vinyl

Glides

- Color-matched plastic on leg-base chair
- Color-matched soft plastic on leg-base chair (option)

Casters

- Hard, black plastic wheels on swivel-base chair and stool
- Soft, dual-wheel roll-control black plastic wheels (option)

All Steelcase seating with standard upholstery fabrics

complies with requirements of the State of California Technical Bulletin 117-2013. All standard seating is labeled to be in compliance with California 117-2013.

Programs & Services

▶ See the *Surface Materials Reference Manual* for further detail about programs and services offered for seating.

The Customer's Own Material (COM) Program

offers the opportunity for customers to select fabrics that are not offered through the standard Steelcase surface materials program for use on Steelcase products. Through the COM program, Steelcase will test your materials for application on Steelcase products. Once approved, you can place your order. Steelcase will facilitate the entire ordering process and give you a production schedule. Steelcase will order the COM fabric directly from the textile manufacturer. For up-to-date information regarding fabric test results for all COM fabrics and details regarding yardage requirements for most Seating lines, visit the COM website. To locate the COM website:

- Visit www.steelcase.com

Soil retardants are treatments that provide long-term soil and stain resistance to a fabric without affecting the shade or the integrity of the fabric. The following Steelcase Textiles are available pre-treated with soil retardant. (You do not need to select the soil-retardant option for these fabrics and incur the upcharge.)

- Jacks
- Link
- Spyder

For information on soil retardant fabrics on Select Surfaces, please refer to the *Surface Materials Reference Manual*.

Soil-retardant treatment is available on all other seating fabrics at an additional upcharge per seating unit. To order this option, please select "Soil-Retardant Treatment" under "Optional Accessories."

For soil-retardant treatment on COMs, please select "Soil-Retardant Treatment" under "Optional Accessories." Minimums or additional yardage may be required. Please contact the vendor directly for specific information.

Extended lead times may be necessary for this service.

Contact your Steelcase Solutions Fulfillment Team Representative at 1.888.STEELCASE (1.888.783.3522) or send an email to lineone@steelcase.com.

Local codes may have special requirements for upholstery.

Dimensions

▶ Page 196

Resources

Printed Materials

▶ Cachet Product Brochure (08-0001115)

Online Resources

▶ Environmental profiles available on www.steelcase.com/sustainability

Dimensions

Cachet 487 Series

Features	Overall Depth	Width	Height	Seat Depth	Functional Seat Depth	Seat Width*	Seat Height from Floor	Ring Height from Floor	Back Width	Back Height from Seat	Back Lumbar Height
----------	---------------	-------	--------	------------	-----------------------	-------------	------------------------	------------------------	------------	-----------------------	--------------------

Cachet 487 Series

Leg-Base Multi-Use Chairs

Fixed-Height	20 ¹ / ₂ "	23"	34 ¹ / ₄ "	19 ³ / ₈ "	16 ⁷ / ₈ "	16 ³ / ₈ "	17 ⁵ / ₈ "	N.A.	18 ¹ / ₂ "	18 ³ / ₄ "	8"
--------------	----------------------------------	-----	----------------------------------	----------------------------------	----------------------------------	----------------------------------	----------------------------------	------	----------------------------------	----------------------------------	----

Swivel-Base Work Chairs

Pneumatic	25"	25"	32 ¹ / ₈ "– 37 ¹ / ₈ "	19 ³ / ₈ "	16 ⁷ / ₈ "	16 ³ / ₈ "	15 ¹ / ₂ "– 20 ¹ / ₂ "	N.A.	18 ¹ / ₂ "	18 ³ / ₄ "	8"
-----------	-----	-----	---	----------------------------------	----------------------------------	----------------------------------	---	------	----------------------------------	----------------------------------	----

Stools

	25"	25"	39"–46"	19 ³ / ₈ "	16 ⁷ / ₈ "	16 ³ / ₈ "	23"–30"	11 ¹ / ₄ "– 13 ¹ / ₄ "	18 ¹ / ₂ "	18 ³ / ₄ "	8"
--	-----	-----	---------	----------------------------------	----------------------------------	----------------------------------	---------	---	----------------------------------	----------------------------------	----

* **Seat width dimension** is taken close to the front edge of the seat. The dimension closer to the actual sitting surface is 19".

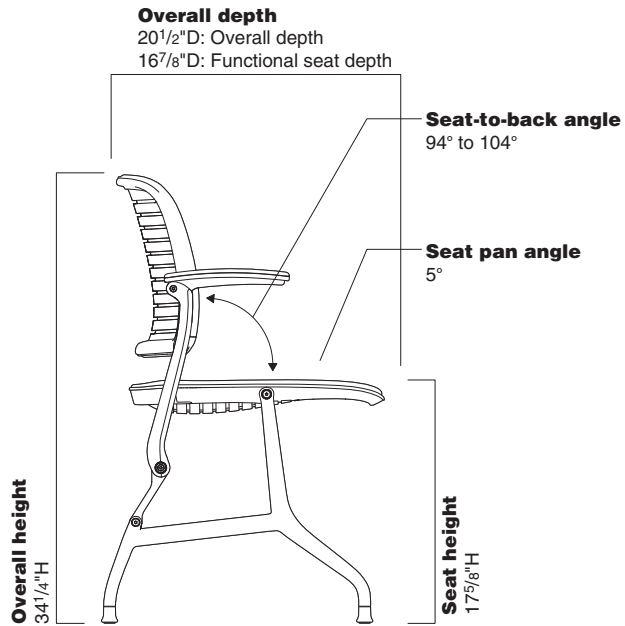
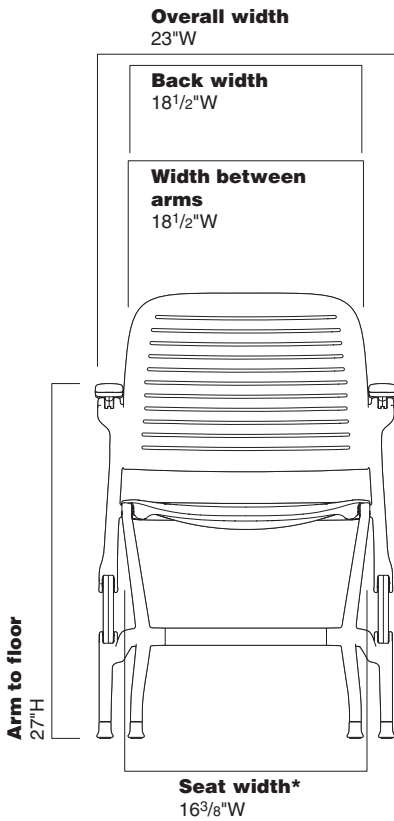

Leg-Base Multi-Use Chair

• **Width Between Arms**
 • **Arm to Floor**
 • **Arm Height from Seat**
 • **Seat Pan Angle**
 • **Angle Between Seat and Back**

Leg-Base Multi-Use Chairs

18 1/2" 27" 10 3/4" 5° 94°–104°

Swivel-Base Work Chairs

18 1/2" 25"–30" 10 3/4" 5° 94°–107°

Stools

18 1/2" 33"–40" 10 3/4" 5° 94°–107°

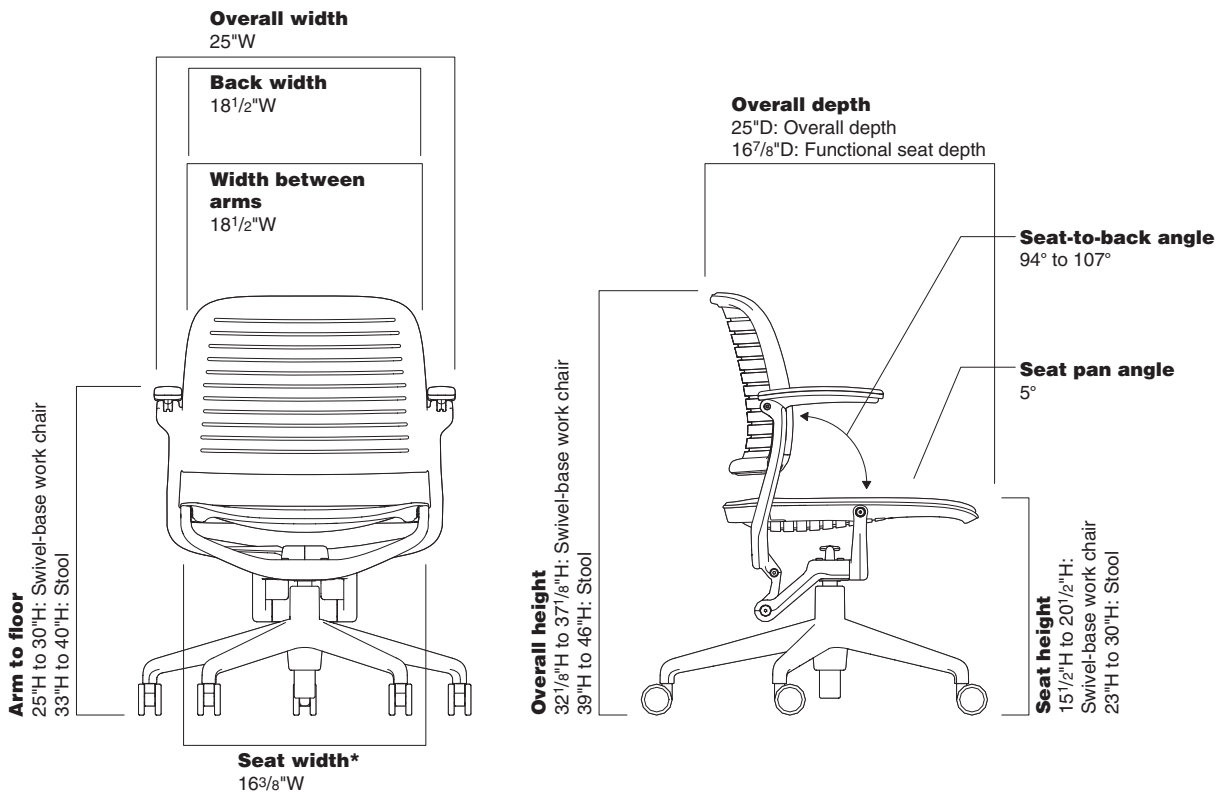

Swivel-Base Work Chair

Cachet 487 Series

Cachet 487 Series Swivel-Base Work Chairs

SIN 711.18



Standard Includes	Required to Specify
<ul style="list-style-type: none"> ▶ Need help? Product details, page 194 Balanced-action rocker (BAR) mechanism Frame, seat, back, flip-up arms, and five-arm base: plastic 5" pneumatic seat-height adjustment Upholstery, if selected: fabric price group 1 2$\frac{3}{8}$" diameter, hard composition, dual-wheel casters: black plastic 	<ol style="list-style-type: none"> Style number Plastic color number for frame, seat, back, flip-up arms, and five-arm base Fabric color number for upholstery on seat and back, or seat, if selected Options, if selected (see below) <ul style="list-style-type: none"> ▶ See <i>Surface Materials</i>, page 432.

Surface Materials	Options	Price	Required to Specify
	Upholstery on seat and back		
	<ul style="list-style-type: none"> Fabric price group 1 Fabric price group 2 Fabric price group 3 Fabric price group 4 Fabric price group 5 Fabric price group 6 Fabric price group 7 Fabric price group 8 Fabric price group 9 Fabric price group 10 Steelcase leather upholstery 	<ul style="list-style-type: none"> No cost +\$ 26 +\$ 48 +\$ 68 +\$ 85 +\$106 +\$121 +\$153 +\$188 +\$213 +\$182 	<ul style="list-style-type: none"> Specify fabric color number. Specify fabric color number. Specify fabric color number. Specify fabric color number. Specify fabric color number. Specify fabric color number. Specify fabric color number. Specify fabric color number. Specify fabric color number. Specify fabric color number. Specify fabric color number. Add suffix S to the style number and specify leather color number. Add suffix S to the style number and specify Select Surfaces leather price group 1. ▶ See <i>Surface Materials Reference Manual</i> Add suffix S to the style number and specify Elmosoft leather color number. Add suffix S to the style number and specify Select Surfaces leather price group 2. ▶ See <i>Surface Materials Reference Manual</i> ▶ See <i>Surface Materials Reference Manual</i> to specify. Add suffix S to the style number and specify leather color number. ▶ See <i>Surface Materials Reference Manual</i> to specify.
	<ul style="list-style-type: none"> Select Surfaces leather price group 1 Elmosoft leather upholstery Select Surfaces leather price group 2 Customer's Own Material (COM) Customer's Own Leather (COL) 	<ul style="list-style-type: none"> +\$182 +\$212 +\$212 No cost No cost 	<ul style="list-style-type: none"> ▶ See <i>Surface Materials Reference Manual</i> Add suffix S to the style number and specify leather color number. ▶ See <i>Surface Materials Reference Manual</i> to specify. Add suffix S to the style number and specify leather color number. ▶ See <i>Surface Materials Reference Manual</i> to specify.
	Contrasting upholstery on seat and back		
	<ul style="list-style-type: none"> Contrasting fabrics 	<ul style="list-style-type: none"> +\$ 31 	<ul style="list-style-type: none"> Add suffix K to the style number and specify fabric color numbers.
	Contrasting upholstery on seat		
	<ul style="list-style-type: none"> Fabric price group 1 Fabric price group 2 Fabric price group 3 Fabric price group 4 Fabric price group 5 Fabric price group 6 Fabric price group 7 Fabric price group 8 Fabric price group 9 Fabric price group 10 Steelcase leather upholstery 	<ul style="list-style-type: none"> No cost +\$ 13 +\$ 24 +\$ 34 +\$ 42 +\$ 53 +\$ 60 +\$ 76 +\$ 94 +\$106 +\$ 91 	<ul style="list-style-type: none"> Specify fabric color number. Specify fabric color number. Specify fabric color number. Specify fabric color number. Specify fabric color number. Specify fabric color number. Specify fabric color number. Specify fabric color number. Specify fabric color number. Specify fabric color number. Specify fabric color number. Add suffix S to the style number and specify leather color number. Add suffix S to the style number and specify leather color number. Add suffix S to the style number and specify leather color number. ▶ See <i>Surface Materials Reference Manual</i> to specify. Add suffix S to the style number and specify leather color number.
	<ul style="list-style-type: none"> Select Surfaces leather price group 1 Elmosoft leather upholstery Select Surfaces leather price group 2 Customer's Own Material (COM) Customer's Own Leather (COL) 	<ul style="list-style-type: none"> +\$ 91 +\$106 +\$106 No cost No cost 	<ul style="list-style-type: none"> ▶ See <i>Surface Materials Reference Manual</i> to specify. Add suffix S to the style number and specify leather color number.

▶ Detailed dimensions, page 196

▶ Options, continued on next page

SIN 711.18

► Options, continued from previous page

Options	Price	Required to Specify
Surface Materials, continued		
Contrasting upholstery on back		
• Fabric price group 1	No cost	Specify fabric color number.
• Fabric price group 2	+\$ 13	Specify fabric color number.
• Fabric price group 3	+\$ 24	Specify fabric color number.
• Fabric price group 4	+\$ 34	Specify fabric color number.
• Fabric price group 5	+\$ 43	Specify fabric color number.
• Fabric price group 6	+\$ 53	Specify fabric color number.
• Fabric price group 7	+\$ 61	Specify fabric color number.
• Fabric price group 8	+\$ 77	Specify fabric color number.
• Fabric price group 9	+\$ 94	Specify fabric color number.
• Fabric price group 10	+\$107	Specify fabric color number.
• Steelcase leather upholstery	+\$ 91	Add suffix S to the style number and specify leather color number.
• Select Surfaces leather price group 1	+\$ 91	Add suffix S to the style number and specify leather color number.
• Elmosoft leather upholstery	+\$106	Add suffix S to the style number and specify leather color number.
• Select Surfaces leather price group 2	+\$106	Add suffix S to the style number and specify leather color number.
• Customer's Own Material (COM)	No cost	► See <i>Surface Materials Reference Manual</i> to specify.
• Customer's Own Leather (COL)	No cost	Add suffix S to the style number and specify leather color number.
Soil-retardant treatment	+\$ 25	Specify with <i>soil-retardant treatment</i> .
Casters		
• Soft, dark grey treaded, dual-wheel roll-control casters for use on hard floors: black plastic	+\$ 25	Specify with <i>soft roll-control casters</i> .

Specification Information

Without Upholstery



• Style Number

• Base Price

4871110 \$730

With Upholstered Seat



• Style Number

• Base Price

4871210 \$876

With Upholstered Seat and Back



• Style Number

• Base Price

4871211 \$946

Cachet 487 Series Leg-Base Multi-Use Chairs

SIN 711.18



Standard Includes	Required to Specify
<ul style="list-style-type: none"> ▶ Need help? Product details, page 194 • Balanced-action rocker (BAR) mechanism • Frame, seat, back, and four-leg base: plastic • Flip-up arms, if selected: plastic color to match frame, seat, and four-leg base • Upholstery, if selected: fabric price group 1 • Hard glides: color-matched to frame 	<ol style="list-style-type: none"> 1 Style number 2 Plastic color number for frame, seat, back, four-leg base, and flip-up arms, if selected 3 Fabric color number for upholstery on seat and back, or seat, if selected 4 Options, if selected (see below) <p>▶ See <i>Surface Materials</i>, page 432.</p>

Options	Price	Required to Specify
Surface Materials		
Upholstery on seat and back		
• Fabric price group 1	No cost	Specify fabric color number.
• Fabric price group 2	+\$ 26	Specify fabric color number.
• Fabric price group 3	+\$ 48	Specify fabric color number.
• Fabric price group 4	+\$ 68	Specify fabric color number.
• Fabric price group 5	+\$ 85	Specify fabric color number.
• Fabric price group 6	+\$106	Specify fabric color number.
• Fabric price group 7	+\$121	Specify fabric color number.
• Fabric price group 8	+\$153	Specify fabric color number.
• Fabric price group 9	+\$188	Specify fabric color number.
• Fabric price group 10	+\$213	Specify fabric color number.
• Steelcase leather upholstery	+\$182	Add suffix S to the style number and specify leather color number.
• Select Surfaces leather price group 1	+\$182	Add suffix S to the style number and specify Select Surfaces leather price group 1.
• Elmosoft leather upholstery	+\$212	▶ See <i>Surface Materials Reference Manual</i> Add suffix S to the style number and specify Elmosoft leather color number.
• Select Surfaces leather price group 2	+\$212	Add suffix S to the style number and specify Select Surfaces leather price group 2.
• Customer's Own Material (COM)	No cost	▶ See <i>Surface Materials Reference Manual</i> ▶ See <i>Surface Materials Reference Manual</i> to specify.
• Customer's Own Leather (COL)	No cost	Add suffix S to the style number and specify leather color number. ▶ See <i>Surface Materials Reference Manual</i> to specify.

Contrasting upholstery on seat and back

• Contrasting fabrics	+\$ 31	Add suffix K to the style number and specify fabric color numbers.
-----------------------	--------	---

Contrasting upholstery on seat

• Fabric price group 1	No cost	Specify fabric color number.
• Fabric price group 2	+\$ 13	Specify fabric color number.
• Fabric price group 3	+\$ 24	Specify fabric color number.
• Fabric price group 4	+\$ 34	Specify fabric color number.
• Fabric price group 5	+\$ 42	Specify fabric color number.
• Fabric price group 6	+\$ 53	Specify fabric color number.
• Fabric price group 7	+\$ 60	Specify fabric color number.
• Fabric price group 8	+\$ 76	Specify fabric color number.
• Fabric price group 9	+\$ 94	Specify fabric color number.
• Fabric price group 10	+\$106	Specify fabric color number.
• Steelcase leather upholstery	+\$ 91	Add suffix S to the style number and specify leather color number.
• Select Surfaces leather price group 1	+\$ 91	Add suffix S to the style number and specify leather color number.
• Elmosoft leather upholstery	+\$106	Add suffix S to the style number and specify leather color number.
• Select Surfaces leather price group 2	+\$106	Add suffix S to the style number and specify leather color number.
• Customer's Own Material (COM)	No cost	▶ See <i>Surface Materials Reference Manual</i> to specify.
• Customer's Own Leather (COL)	No cost	Add suffix S to the style number and specify leather color number.

▶ Detailed dimensions, page 196

▶ Options, continued on next page

SIN 711.18

► Options, continued from previous page

Options	Price	Required to Specify
Surface Materials, continued		
Contrasting upholstery on back		
• Fabric price group 1	No cost	Specify fabric color number.
• Fabric price group 2	+\$ 13	Specify fabric color number.
• Fabric price group 3	+\$ 24	Specify fabric color number.
• Fabric price group 4	+\$ 34	Specify fabric color number.
• Fabric price group 5	+\$ 43	Specify fabric color number.
• Fabric price group 6	+\$ 53	Specify fabric color number.
• Fabric price group 7	+\$ 61	Specify fabric color number.
• Fabric price group 8	+\$ 77	Specify fabric color number.
• Fabric price group 9	+\$ 94	Specify fabric color number.
• Fabric price group 10	+\$107	Specify fabric color number.
• Steelcase leather upholstery	+\$ 91	Add suffix S to the style number and specify leather color number.
• Select Surfaces leather price group 1	+\$ 91	Add suffix S to the style number and specify leather color number.
• Elmosoft leather upholstery	+\$106	Add suffix S to the style number and specify leather color number.
• Select Surfaces leather price group 2	+\$106	Add suffix S to the style number and specify leather color number.
• Customer's Own Material (COM)	No cost	► See <i>Surface Materials Reference Manual</i> to specify.
• Customer's Own Leather (COL)	No cost	Add suffix S to the style number and specify leather color number.
Soil-retardant treatment	+\$ 25	Specify with <i>soil-retardant treatment</i> .
Glides		
• Soft felt glides: color matched to frame	+\$ 10	Specify with <i>soft glides</i> .

Specification Information

Without Upholstery



• Style Number
• Base Price

With Upholstered Seat



• Style Number
• Base Price

With Upholstered Seat and Back



• Style Number
• Base Price

Without Arms

4878100 \$438

4878200 \$584

4878201 \$654

Without Upholstery



• Style Number
• Base Price

With Upholstered Seat



• Style Number
• Base Price

With Upholstered Seat and Back



• Style Number
• Base Price

With Flip-Up Arms

4878110 \$556

4878210 \$702

4878211 \$772

Cachet 487 Series

Cachet 487 Series Swivel-Base Stools

SIN 711.18



Standard Includes	Required to Specify
<ul style="list-style-type: none"> ▶ Need help? Product details, page 194 • Balanced-action rocker (BAR) mechanism • Frame, seat, back, flip-up arms, and five-arm base: black plastic • 7¾" pneumatic seat-height adjustment • Upholstery, if selected: fabric price group 1 • 2⅜" diameter, hard composition, dual-wheel casters: black plastic 	<ol style="list-style-type: none"> 1 Style number 2 Fabric color number for upholstery on seat and back, or seat, if selected 3 Options, if selected (see below) <ul style="list-style-type: none"> ▶ See <i>Surface Materials</i>, page 432.

Surface Materials	Options	Price	Required to Specify
	Upholstery on seat and back		
	• Fabric price group 1	No cost	Specify fabric color number.
	• Fabric price group 2	+\$ 26	Specify fabric color number.
	• Fabric price group 3	+\$ 48	Specify fabric color number.
	• Fabric price group 4	+\$ 68	Specify fabric color number.
	• Fabric price group 5	+\$ 85	Specify fabric color number.
	• Fabric price group 6	+\$106	Specify fabric color number.
	• Fabric price group 7	+\$121	Specify fabric color number.
	• Fabric price group 8	+\$153	Specify fabric color number.
	• Fabric price group 9	+\$188	Specify fabric color number.
	• Fabric price group 10	+\$213	Specify fabric color number.
	• Steelcase leather upholstery	+\$182	Add suffix S to the style number and specify leather color number.
	• Select Surfaces leather price group 1	+\$182	Add suffix S to the style number and specify Select Surfaces leather price group 1.
	• Elmosoft leather upholstery	+\$212	▶ See <i>Surface Materials Reference Manual</i> Add suffix S to the style number and specify Elmosoft leather color number.
	• Select Surfaces leather price group 2	+\$212	Add suffix S to the style number and specify Select Surfaces leather price group 2.
	• Customer's Own Material (COM)	No cost	▶ See <i>Surface Materials Reference Manual</i>
	• Customer's Own Leather (COL)	No cost	▶ See <i>Surface Materials Reference Manual</i> to specify. Add suffix S to the style number and specify leather color number.
			▶ See <i>Surface Materials Reference Manual</i> to specify.
	Contrasting upholstery on seat and back		
	• Contrasting fabrics	+\$ 31	Add suffix K to the style number and specify fabric color numbers.
	Contrasting upholstery on seat		
	• Fabric price group 1	No cost	Specify fabric color number.
	• Fabric price group 2	+\$ 13	Specify fabric color number.
	• Fabric price group 3	+\$ 24	Specify fabric color number.
	• Fabric price group 4	+\$ 34	Specify fabric color number.
	• Fabric price group 5	+\$ 42	Specify fabric color number.
	• Fabric price group 6	+\$ 53	Specify fabric color number.
	• Fabric price group 7	+\$ 60	Specify fabric color number.
	• Fabric price group 8	+\$ 76	Specify fabric color number.
	• Fabric price group 9	+\$ 94	Specify fabric color number.
	• Fabric price group 10	+\$106	Specify fabric color number.
	• Steelcase leather upholstery	+\$ 91	Add suffix S to the style number and specify leather color number.
	• Select Surfaces leather price group 1	+\$ 91	Add suffix S to the style number and specify leather color number.
	• Elmosoft leather upholstery	+\$106	Add suffix S to the style number and specify leather color number.
	• Select Surfaces leather price group 2	+\$106	Add suffix S to the style number and specify leather color number.
	• Customer's Own Material (COM)	No cost	▶ See <i>Surface Materials Reference Manual</i> to specify.
	• Customer's Own Leather (COL)	No cost	Add suffix S to the style number and specify leather color number.

▶ Detailed dimensions, page 196

▶ Options, continued on next page

► Options, continued from previous page

Options	Price	Required to Specify
Surface Materials, continued		
Contrasting upholstery on back		
• Fabric price group 1	No cost	Specify fabric color number.
• Fabric price group 2	+\$ 13	Specify fabric color number.
• Fabric price group 3	+\$ 24	Specify fabric color number.
• Fabric price group 4	+\$ 34	Specify fabric color number.
• Fabric price group 5	+\$ 43	Specify fabric color number.
• Fabric price group 6	+\$ 53	Specify fabric color number.
• Fabric price group 7	+\$ 61	Specify fabric color number.
• Fabric price group 8	+\$ 77	Specify fabric color number.
• Fabric price group 9	+\$ 94	Specify fabric color number.
• Fabric price group 10	+\$107	Specify fabric color number.
• Steelcase leather upholstery	+\$ 91	Add suffix S to the style number and specify leather color number.
• Select Surfaces leather price group 1	+\$ 91	Add suffix S to the style number and specify leather color number.
• Elmosoft leather upholstery	+\$106	Add suffix S to the style number and specify leather color number.
• Select Surfaces leather price group 2	+\$106	Add suffix S to the style number and specify leather color number.
• Customer's Own Material (COM)	No cost	► See <i>Surface Materials Reference Manual</i> to specify.
• Customer's Own Leather (COL)	No cost	Add suffix S to the style number and specify leather color number.
Soil-retardant treatment	+\$ 25	Specify with <i>soil-retardant treatment</i> .
Casters	+\$ 25	Specify with <i>soft roll-control casters</i> .
• Soft, dark grey treaded, dual-wheel roll-control casters for use on hard floors: black plastic		

Specification Information

Without Upholstery



• Style Number

• Base Price

4877110 \$1044

With Upholstered Seat



• Style Number

• Base Price

4877210 \$1190

With Upholstered Seat and Back



• Style Number

• Base Price

4877211 \$1260

Cushion Upholstery Packages

SIN 711.18

Cushion Upholstery Package for Back and Seat

For Use on Leg-Base, Swivel, and Stool Models

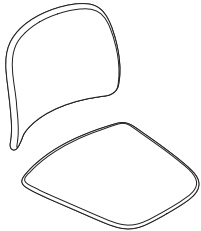

Standard Includes	Required to Specify
-------------------	---------------------

- | | | |
|--|--|--|
| ▶ Need help?
Product details,
page 194 | <ul style="list-style-type: none"> • Package of one seat and one back cushion • Cushion upholstery for seat and back:
fabric price group 1 • Outer back: plastic to match chair | <ol style="list-style-type: none"> 1 Style number 2 Fabric color number 3 Specify plastic color of back to match chair 4 Options, if selected (see below) <p>▶ See <i>Surface Materials</i>, page 432.</p> |
|--|--|--|

Options	Price	Required to Specify
---------	-------	---------------------

Surface Materials	Upholstery on seat and back		
	<ul style="list-style-type: none"> • Fabric price group 1 • Fabric price group 2 • Fabric price group 3 • Fabric price group 4 • Fabric price group 5 • Fabric price group 6 • Fabric price group 7 • Fabric price group 8 • Fabric price group 9 • Fabric price group 10 • Steelcase leather upholstery 	No cost +\$ 26 +\$ 48 +\$ 68 +\$ 85 +\$106 +\$121 +\$153 +\$188 +\$213 +\$182	Specify fabric color number. Specify fabric color number. Specify fabric color number. Specify fabric color number. Specify fabric color number. Specify fabric color number. Specify fabric color number. Specify fabric color number. Specify fabric color number. Specify fabric color number. Add suffix S to the style number and specify leather color number. Add suffix S to the style number and specify Select Surfaces leather price group 1. ▶ See <i>Surface Materials Reference Manual</i> Add suffix S to the style number and specify Elmosoft leather color number. Add suffix S to the style number and specify Select Surfaces leather price group 2. ▶ See <i>Surface Materials Reference Manual</i> ▶ See <i>Surface Materials Reference Manual</i> to specify. Add suffix S to the style number and specify leather color number. ▶ See <i>Surface Materials Reference Manual</i> to specify.
	<ul style="list-style-type: none"> • Select Surfaces leather price group 1 	+\$182	
	<ul style="list-style-type: none"> • Elmosoft leather upholstery 	+\$212	
	<ul style="list-style-type: none"> • Select Surfaces leather price group 2 	+\$212	
	<ul style="list-style-type: none"> • Customer's Own Material (COM) 	No cost	
	<ul style="list-style-type: none"> • Customer's Own Leather (COL) 	No cost	
	Contrasting upholstery on seat and back		
	<ul style="list-style-type: none"> • Contrasting fabrics 	+\$ 31	Add suffix K to the style number and specify fabric color numbers.

▶ Options, continued on next page

▶ Detailed dimensions,
page 196

► Options, continued from previous page

Options	Price	Required to Specify
Surface Materials, continued		
Contrasting upholstery on seat		
• Fabric price group 1	No cost	Specify fabric color number.
• Fabric price group 2	+\$ 13	Specify fabric color number.
• Fabric price group 3	+\$ 24	Specify fabric color number.
• Fabric price group 4	+\$ 34	Specify fabric color number.
• Fabric price group 5	+\$ 42	Specify fabric color number.
• Fabric price group 6	+\$ 53	Specify fabric color number.
• Fabric price group 7	+\$ 60	Specify fabric color number.
• Fabric price group 8	+\$ 76	Specify fabric color number.
• Fabric price group 9	+\$ 94	Specify fabric color number.
• Fabric price group 10	+\$106	Specify fabric color number.
• Steelcase leather upholstery	+\$ 91	Add suffix S to the style number and specify leather color number.
• Select Surfaces leather price group 1	+\$ 91	Add suffix S to the style number and specify leather color number.
• Elmosoft leather upholstery	+\$106	Add suffix S to the style number and specify leather color number.
• Select Surfaces leather price group 2	+\$106	Add suffix S to the style number and specify leather color number.
• Customer's Own Material (COM)	No cost	► See <i>Surface Materials Reference Manual</i> to specify.
• Customer's Own Leather (COL)	No cost	Add suffix S to the style number and specify leather color number.
Contrasting upholstery on back		
• Fabric price group 1	No cost	Specify fabric color number.
• Fabric price group 2	+\$ 13	Specify fabric color number.
• Fabric price group 3	+\$ 24	Specify fabric color number.
• Fabric price group 4	+\$ 34	Specify fabric color number.
• Fabric price group 5	+\$ 43	Specify fabric color number.
• Fabric price group 6	+\$ 53	Specify fabric color number.
• Fabric price group 7	+\$ 61	Specify fabric color number.
• Fabric price group 8	+\$ 77	Specify fabric color number.
• Fabric price group 9	+\$ 94	Specify fabric color number.
• Fabric price group 10	+\$107	Specify fabric color number.
• Steelcase leather upholstery	+\$ 91	Add suffix S to the style number and specify leather color number.
• Select Surfaces leather price group 1	+\$ 91	Add suffix S to the style number and specify leather color number.
• Elmosoft leather upholstery	+\$106	Add suffix S to the style number and specify leather color number.
• Select Surfaces leather price group 2	+\$106	Add suffix S to the style number and specify leather color number.
• Customer's Own Material (COM)	No cost	► See <i>Surface Materials Reference Manual</i> to specify.
• Customer's Own Leather (COL)	No cost	Add suffix S to the style number and specify leather color number.
Soil-retardant treatment	+\$ 25	Specify with soil-retardant treatment.

Specification Information

Style Number	Base Price
487STBK	\$327

Package of 1 Back Cushion and 1 Seat Cushion

487STBK	\$327
---------	-------

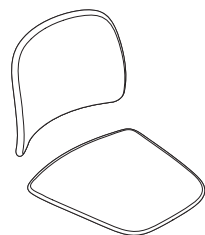

Cushion Upholstery Packages, continued

SIN 711.18

Cushion Upholstery Package for Back

For Use on Leg-Base, Swivel, and Stool Models

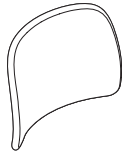

Standard Includes	Required to Specify
-------------------	---------------------

- | | | |
|--|---|--|
| <ul style="list-style-type: none"> ▶ Need help? Product details, page 194 | <ul style="list-style-type: none"> • One back cushion • Cushion upholstery for back: fabric price group 1 • Outer back: plastic to match chair | <ol style="list-style-type: none"> 1 Style number 2 Fabric color number for cushion 3 Specify plastic color of back to match chair 4 Options, if selected (see below) <p>▶ See <i>Surface Materials</i>, page 432.</p> |
|--|---|--|

Options	Price	Required to Specify
---------	-------	---------------------

Surface Materials	<ul style="list-style-type: none"> • Fabric price group 1 • Fabric price group 2 • Fabric price group 3 • Fabric price group 4 • Fabric price group 5 • Fabric price group 6 • Fabric price group 7 • Fabric price group 8 • Fabric price group 9 • Fabric price group 10 • Steelcase leather upholstery • Select Surfaces leather price group 1 • Elmosoft leather upholstery • Select Surfaces leather price group 2 • Customer's Own Material (COM) • Customer's Own Leather (COL) 	<p>No cost</p> <p>+\$ 10</p> <p>+\$ 26</p> <p>+\$ 35</p> <p>+\$ 42</p> <p>+\$ 51</p> <p>+\$ 62</p> <p>+\$ 77</p> <p>+\$ 94</p> <p>+\$109</p> <p>+\$ 91</p> <p>+\$ 91</p> <p>+\$107</p> <p>+\$107</p> <p>No cost</p> <p>No cost</p>	<p>Specify fabric color number.</p> <p>Specify fabric color number.</p> <p>Specify fabric color number.</p> <p>Specify fabric color number.</p> <p>Specify fabric color number.</p> <p>Specify fabric color number.</p> <p>Specify fabric color number.</p> <p>Specify fabric color number.</p> <p>Specify fabric color number.</p> <p>Specify fabric color number.</p> <p>Specify fabric color number.</p> <p>Add suffix S to the style number and specify leather color number.</p> <p>Add suffix S to the style number and specify Select Surfaces leather price group 1.</p> <p>▶ See <i>Surface Materials Reference Manual</i>.</p> <p>Add suffix S to the style number and specify Elmosoft leather color number.</p> <p>Add suffix S to the style number and specify Select Surfaces leather price group 2.</p> <p>▶ See <i>Surface Materials Reference Manual</i>.</p> <p>▶ See <i>Surface Materials Reference Manual</i> to specify.</p> <p>Add suffix S to the style number and specify leather color number.</p> <p>▶ See <i>Surface Materials Reference Manual</i>.</p>
	Soil-retardant treatment	+\$ 25	Specify with soil-retardant treatment.

Specification Information	
Style Number	Base Price

487BK	\$181
:	:
:	:

Cushion Upholstery Package for Seat
For Use on Leg-Base, Swivel, and Stool Models



Standard Includes	Required to Specify
<ul style="list-style-type: none"> ▶ Need help? Product details, page 194 • One seat cushion • Cushion upholstery for seat: fabric price group 1 	<ul style="list-style-type: none"> 1 Style number 2 Fabric color number for cushion 3 Options, if selected (see below) ▶ See <i>Surface Materials</i>, page 432.

Options	Price	Required to Specify
Surface Materials		
• Fabric price group 1	No cost	Specify fabric color number.
• Fabric price group 2	+\$ 10	Specify fabric color number.
• Fabric price group 3	+\$ 26	Specify fabric color number.
• Fabric price group 4	+\$ 35	Specify fabric color number.
• Fabric price group 5	+\$ 42	Specify fabric color number.
• Fabric price group 6	+\$ 51	Specify fabric color number.
• Fabric price group 7	+\$ 62	Specify fabric color number.
• Fabric price group 8	+\$ 77	Specify fabric color number.
• Fabric price group 9	+\$ 94	Specify fabric color number.
• Fabric price group 10	+\$109	Specify fabric color number.
• Steelcase leather upholstery	+\$ 91	Add suffix S to the style number and specify leather color number.
• Select Surfaces leather price group 1	+\$ 91	Add suffix S to the style number and specify Select Surfaces leather price group 1.
• Elmosoft leather upholstery	+\$107	▶ See <i>Surface Materials Reference Manual</i> . Add suffix S to the style number and specify Elmosoft leather color number.
• Select Surfaces leather price group 2	+\$107	Add suffix S to the style number and specify Select Surfaces leather price group 2.
• Customer's Own Material (COM)	No cost	▶ See <i>Surface Materials Reference Manual</i> .
• Customer's Own Leather (COL)	No cost	▶ See <i>Surface Materials Reference Manual</i> to specify. Add suffix S to the style number and specify leather color number.
		▶ See <i>Surface Materials Reference Manual</i> .
Soil-retardant treatment	+\$ 25	Specify <i>with soil-retardant treatment</i> .

Specification Information	
Style Number	Base Price
487ST	\$181
:	:
:	:

Cachet 487 Series

▶ Detailed dimensions, page 196

Cachet 487 Series Accessories

SIN 711.18

Transport and Storage Dolly

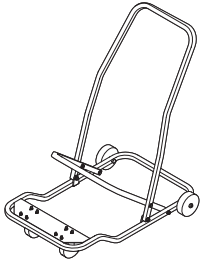

Tip: Transport and storage dolly is for leg-base chairs only.

Standard Includes	Required to Specify
<ul style="list-style-type: none"> ▶ Need help? Product details, page 195 • Transport and storage dolly: black paint only 	<ul style="list-style-type: none"> Style number

Specification Information	
• Style Number	• Price
487D	\$582
:	:
:	:

Ganging and Alignment Devices

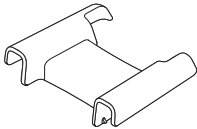

Tip: Ganging and alignment devices are for leg-base chairs only.

Standard Includes	Required to Specify
<ul style="list-style-type: none"> ▶ Need help? Product details, page 195 • Carton of 5 devices: color matched to frame 	<ul style="list-style-type: none"> 1 Style number 2 Plastic color number to match chair ▶ See <i>Surface Materials</i>, page 432.

Specification Information	
• Style Number	• Price
487G	\$58
:	:
:	:

QiVi 428 Series

QiVi is a family of seating, inspired by collaboration and designed to encourage movement and support various postures. With its pivoting backrest and gliding seat, QiVi adjusts automatically to provide comfort for extended periods of time.

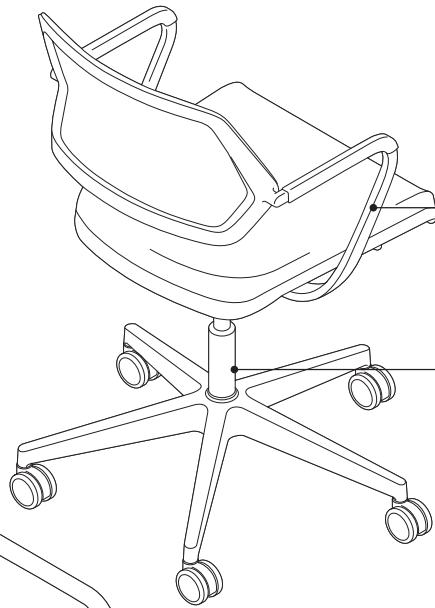

Arms are painted aluminum with a soft touch painted plastic arm cap. Polished aluminum arms are available as an option.

Seat height adjusts 4½" from 17½"H to 22"H with a pneumatic adjustment mechanism.

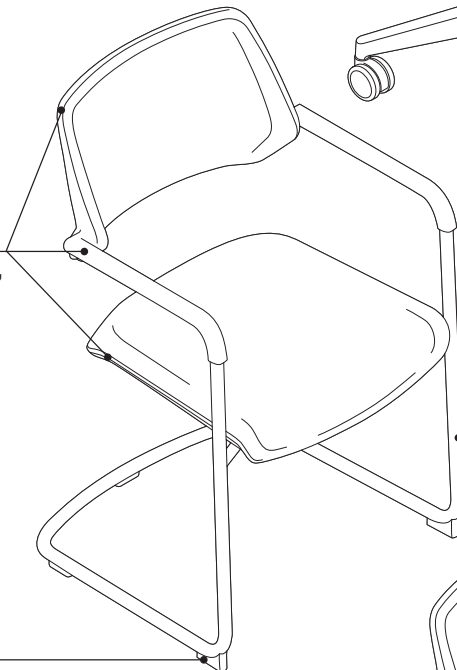

Back frame, seat shell, and arm caps are plastic and will always coordinate finish color.

Frame is painted steel with a soft touch painted plastic arm cap. Polished chrome is available as an option.

Pivoting back rotates 15° automatically, encouraging movement and sitting in multiple postures.

Hard plastic glides are standard, soft glides are available as an option.

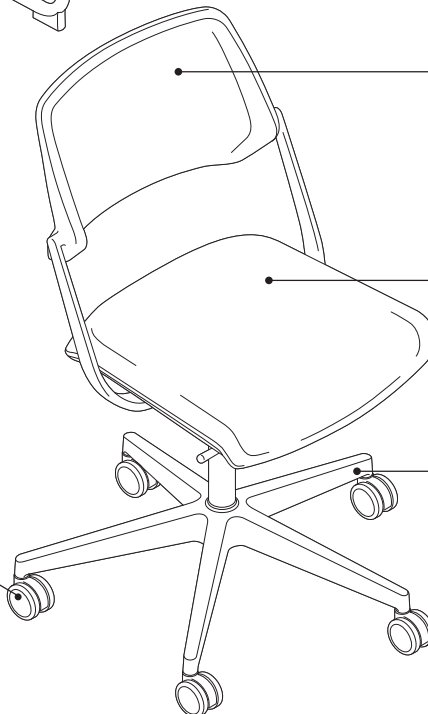

Gliding seat has a 1" range. Movement is automatic and follows the user as they shift postures. A fixed seat is available as an option.

Five-arm base is plastic, a polished aluminum base is available as an option.

Casters have hard, dual-wheels that roll smoothly on carpets. They are 2½" for increased mobility. Soft, dark grey treaded, dual-wheel roll-control casters are available for use on hard floors or chair mats. Stools are standard with 2" hard casters. Soft casters are available as an option.

Tip: Do not roll the chair across asphalt during installation as this may damage the casters.

Product Details



Five-arm base chairs and stools are available with and without arms.

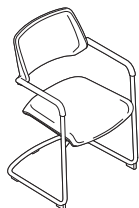

Sled-base is available with arms only.

360° adjustable height swivel mechanism is standard on five-arm base models.

QiVi ships standard assembled and uncartoned. Cartoned shipment is available as an option.

Stacking density for sled-base stacking chairs is three on the floor. Bases on the stacking chairs have a slight bend at the front of each leg.

Adjustment Features

Adjustability instructions are included with every swivel-base chair. Instructions can also be found at www.steelcase.com.

Seat Adjustments

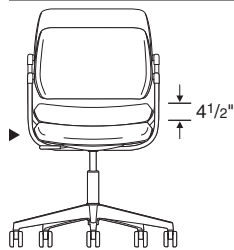

Seat height adjusts pneumatically. To lower, pull lever up while seated. To raise, pull lever up and keep your weight off the chair.

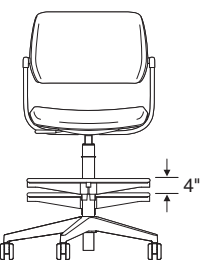

Foot ring height on stools adjusts by first lifting ring and rotating it counter-clockwise to unlock. Then raise or lower ring up to 4" to desired position before rotating it clockwise to lock. The foot ring has a diameter of 20".

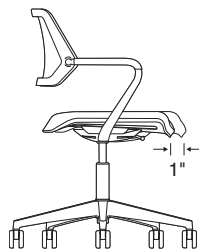

Gliding seat automatically glides forward and back, adjusting to the natural motion of your body. The seat glides within a 1" range and returns to a neutral position when the user leaves the seat. The gliding seat is a standard feature, a fixed seat option is available.

Back Adjustments

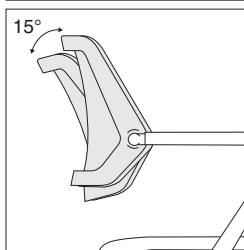

Pivoting back automatically follows the natural motion of your back as you recline, encouraging movement and supporting multiple postures. The backrest pivot range is 15° and will return to the neutral position when the user is not applying pressure to the back.

Other features

Soft wheel casters for hard floors on five-arm base models are available for specific applications.

Hard glides come standard on sled base chairs, soft glides are available as an option.

Surface Materials

► See surface materials on page 432 for specific availability or refer to the *Surface Materials Reference Manual* for further information.

Back upholstery

QiVi Net (back only)

- QN01 Wasabi
- QN02 Licorice
- QN03 Tangerine
- QN04 Graphite
- QN05 Malt
- QN06 Coconut
- QN07 Scarlet
- QN08 Blue Jay
- QN09 Royal Blue
- QN10 Aubergine
- QN11 Peacock
- QN12 Jungle
- QN13 Merlot
- QN14 Honey
- QN15 Lagoon
- QN16 Saffron

Seat upholstery

- Cogent: Connect fabric
- Fabric
- Fabric with soil-retardant treatment (option)
- Leather
- Elmosoft Leather
- Select Surfaces leather
- Vinyl
- COM
- COL

Tip: Some Steelcase seating fabrics are available with and without a stitched detail on the seat. See seating upholstery matrix for details.

Base on QiVi sled-base chairs

Lux Coatings

- 4B20 Obsidian
- 4B22 Matte Brass
- 4B23 Burnished Bronze
- 4B24 Night Bronze
- 4B25 Matte Copper
- 4B26 Smoked Mica
- 4B27 Blue Steel
- 4B28 Silver Lilac
- 4B29 Cast Iron
- 4B30 Bright Gold

Plastic components

Back frame, seat shell, and arm caps

- 6009 Arctic White
- 6205 Black
- 6249 Platinum

Tip: Only one finish can be selected for all three plastic components.

Base, frame, and arms

- 6205 Black
- 7241 Textured Arctic White
- 4799 Platinum Metallic
- 8046 Polished Aluminum (five-arm only)
- 9201 Polished Chrome (sled only)

Castors and glides

- 6205 Black

Foot ring on stools

- 6205 Black
- 6249 Platinum
- 7241 Arctic White

Tip: Foot ring and cylinder on stool will coordinate to match the base color.

All Steelcase seating with standard upholstery fabrics

complies with requirements of the State of California Technical Bulletin 117-2013. All standard seating is labeled to be in compliance with California 117-2013.

Programs & Services

► See the *Surface Materials Reference Manual* for further detail about programs and services offered for seating.

The Customer's Own Material (COM) Program

offers the opportunity for customers to select fabrics that are not offered through the standard Steelcase surface materials program for use on Steelcase products. Through the COM program, Steelcase will test your materials for application on Steelcase products. Once approved, you can place your order. Steelcase will facilitate the entire ordering process and give you a production schedule. Steelcase will order the COM fabric directly from the textile manufacturer. For up-to-date information regarding fabric test results for all COM fabrics and details regarding yardage requirements for most Seating lines, visit the COM website. To locate the COM website:

- Visit www.steelcase.com

Qivi 428 Series, continued

Soil retardants are treatments that provide long-term soil and stain resistance to a fabric without affecting the shade or the integrity of the fabric. The following Steelcase Textiles are available pre-treated with soil retardant. (You do not need to select the soil-retardant option for these fabrics and incur the upcharge.)

- Jacks
- Link
- Spyder

For information on soil retardant fabrics on Select Surfaces, please refer to the *Surface Materials Reference Manual*.

Soil-retardant treatment is available on all other seating fabrics at an additional upcharge per seating unit. To order this option, please select "Soil-Retardant Treatment" under "Optional Accessories."

For soil-retardant treatment on COMs, please select "Soil-Retardant Treatment" under "Optional Accessories." Minimums or additional yardage may be required. Please contact the vendor directly for specific information.

Extended lead times may be necessary for this service.

Contact your Steelcase Solutions Fulfillment Team Representative at 1.888.STEELCASE (1.888.783.3522) or send an email to lineone@steelcase.com.

Fire Codes

▶ See pages 462 for upholstery fabrics available for use with FCS modification.

Steelcase offers Fire Code Seating modification (FCS) on some seating models. The most rigorous fire codes in the nation have been developed in California, and the Steelcase FCS modification is designed to meet those codes. Fire Code Seating (FCS) indicates that a product is constructed to meet the strict fire code requirements of high public occupancy areas such as theaters, meeting rooms, and lobbies. The FCS standards will meet the State of California Bureau of Electronic and Appliance Repair, Home Furnishings, and Thermal Insulation Technical Bulletin 133 (Cal TB 133). Boston adopted the California Bureau of Electronic and Appliance Repair, Home Furnishings, and Thermal Insulation Technical Bulletin TB 133 test standard in 1992.

Local codes may have special requirements for upholstery.

Dimensions

▶ Page 214

Resources

Printed Materials

- ▶ Qivi Brochure (13-0000592)
- ▶ Qivi User Guide (13-0000217)

Online Resources

- ▶ Qivi technical animation available on SteelcaseTV YouTube channel
- ▶ Qivi Commercial available on SteelcaseTV YouTube channel
- ▶ Environmental profiles available on www.steelcase.com/sustainability

Dimensions

QiVi 428 Series

Features	Overall Depth	Width	Height	Seat Depth	Functional Seat Depth	Seat Width	Seat Height from Floor	Ring Height from Floor	Back Width	Back Height from Seat
QiVi 428 Series										
Collaborative Chairs										
	22 ¹ / ₁₆ "	*22 ¹ / ₂ "	33 ¹ / ₄ "–38 ¹ / ₈ "	19 ⁷ / ₈ "	18 ¹ / ₂ "	18 ¹ / ₂ "	17 ¹ / ₂ "–22"	N.A.	18"	16 ¹ / ₂ "
Sled-Base Chairs										
	22 ¹ / ₈ "	22 ¹ / ₁₆ "	34"	19 ⁷ / ₈ "	18 ¹ / ₂ "	18 ¹ / ₂ "	18 ¹ / ₂ "	N.A.	18"	16 ¹ / ₂ "
Stools										
	22 ¹ / ₁₆ "	*22 ¹ / ₂ "	38 ¹ / ₄ "–46 ¹ / ₂ "	19 ⁷ / ₈ "	18 ¹ / ₂ "	18 ¹ / ₂ "	22"–30 ¹ / ₄ "	10 ¹ / ₂ "–14 ¹ / ₂ "	18"	16 ¹ / ₂ "

*Overall width does not include the base.
The diameter of the chair with the five-arm base is 26".

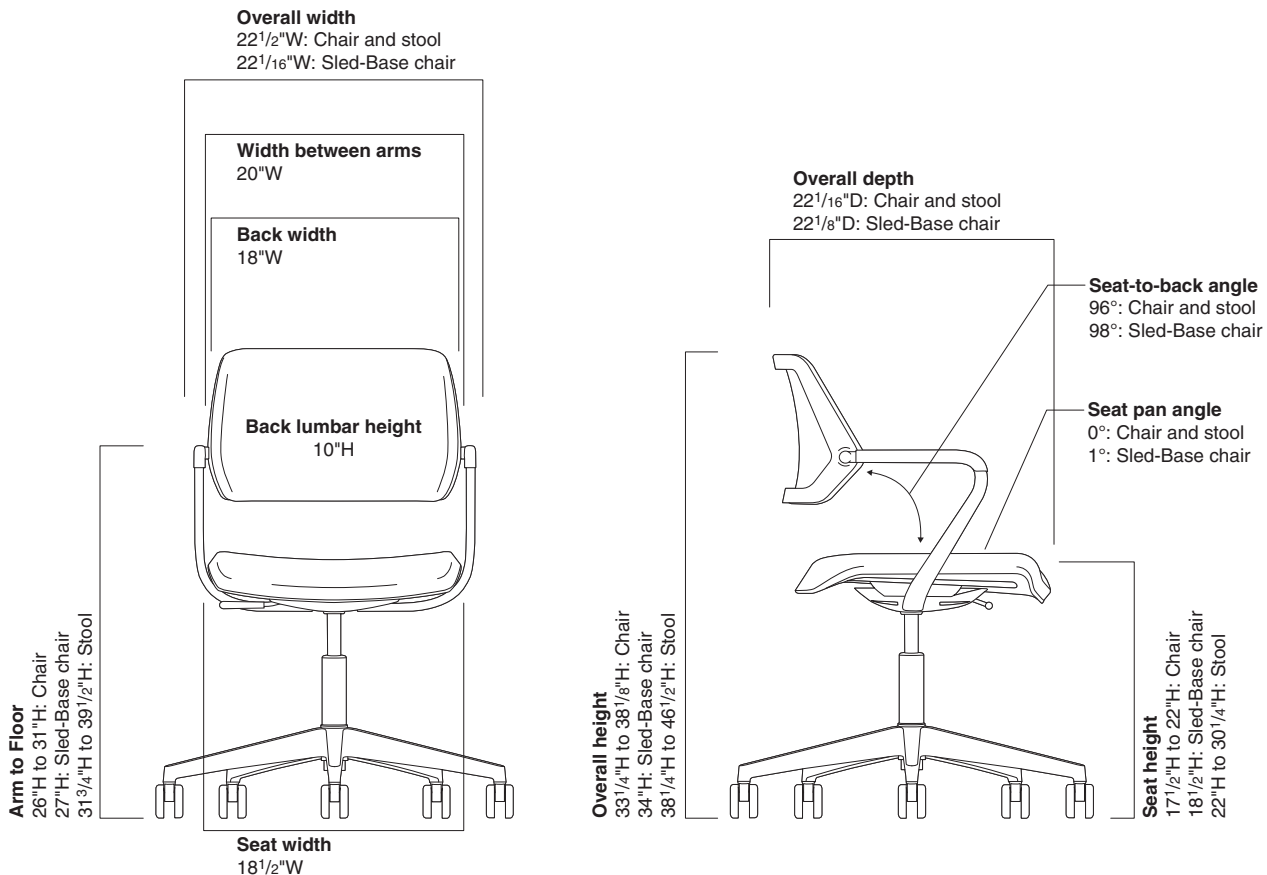

• Back Lumbar Height	• Width Between Arms	• Arm to Floor	• Arm Height from Seat	• Seat Pan Angle	• Angle Between Seat and Back
----------------------	----------------------	----------------	------------------------	------------------	-------------------------------

Collaborative Chairs

10"	20"	26"-31"	8½"	0°	96°
-----	-----	---------	-----	----	-----

Sled-Base Chairs

10"	20"	27"	8½"	1°	98°
-----	-----	-----	-----	----	-----

Stools

10"	20"	31¾"-39½"	8½"	0°	96°
-----	-----	-----------	-----	----	-----

:	:	:	:	:	:
---	---	---	---	---	---

QiVi 428 Series Collaborative Chair

SIN 711.18



Tip: Always add suffixes in alphabetical order when specifying options to QiVi seating.

Tip: Leather and vinyl upcharges are in addition to sewn upholstery upcharge.

Tip: Fire Code Seating (FCS) option is available with certain upholstery fabric choices only.
▶ Page 462

Standard Includes	Required to Specify
<ul style="list-style-type: none"> ▶ Need help? Product details, page 210 • 4½" pneumatic seat-height adjustment (17½" to 22") • Arms, if selected: 6205 black plastic to match base • Seat shell, outer back, and soft touch arm caps: plastic • Five-arm base: 6205 black plastic • QiVi Net upholstery on back • 15° pivoting backrest • Standard upholstery design on seat: fabric price group 1 • 1" gliding seat • 2½"-diameter, hard-composition, dual-wheel casters: black 	<ol style="list-style-type: none"> 1 Style number 2 Plastic color number for base 3 Plastic color number for seat shell, outer back shell, and arm caps, if selected 4 QiVi Net color number for upholstery on back 5 Fabric color number for upholstery on seat 6 Options, if selected (see below) <p>▶ See <i>Surface Materials</i>, page 432.</p>

Options	Price	Required to Specify
Surface Materials		
Upholstery on seat		
• Fabric price group 1	No cost	Specify fabric color number.
• Fabric price group 2	No cost	Specify fabric color number.
• Fabric price group 3	+\$ 26	Specify fabric color number.
• Fabric price group 4	+\$ 35	Specify fabric color number.
• Fabric price group 5	+\$ 42	Specify fabric color number.
• Fabric price group 6	+\$ 51	Specify fabric color number.
• Fabric price group 7	+\$ 62	Specify fabric color number.
• Fabric price group 8	+\$ 77	Specify fabric color number.
• Fabric price group 9	+\$ 94	Specify fabric color number.
• Fabric price group 10	+\$109	Specify fabric color number.
• Steelcase leather upholstery	+\$177	Add suffix S to the style number and specify leather color number.
• Select Surfaces leather price group 1	+\$177	Add suffix S to the style number and specify Select Surfaces leather price group 1.
• Elmosoft leather upholstery	+\$205	▶ See <i>Surface Materials Reference Manual</i> . Add suffix S to the style number and specify Elmosoft leather color number.
• Select Surfaces leather price group 2	+\$205	Add suffix S to the style number and specify Select Surfaces leather price group 2.
• Steelcase vinyl	No cost	▶ See <i>Surface Materials Reference Manual</i> . Add suffix S to the style number and specify vinyl color number.
• Customer's Own Material (COM)	No cost	▶ See <i>Surface Materials Reference Manual</i> .
• Customer's Own Leather (COL)	No cost	Add suffix S to the style number and specify leather color number.
Fire Code Seating (FCS)	+\$ 39	Add suffix F to style number.
Soil-retardant treatment	+\$ 25	Specify <i>with soil-retardant treatment</i> .
Sewn upholstery		
• Sewn upholstery applied	+\$ 41	Add suffix S to the style number.
Base		
• Arctic white	+\$ 57	Specify <i>with 6009 Arctic White</i> .
• Platinum metallic	+\$ 57	Specify <i>with 4799 Platinum Metallic</i> .
• Polished aluminum	+\$131	Specify <i>with polished aluminum</i> .
• Lux Coatings	+\$215	Specify Lux Coatings color number.
Arms		
• Armless	-\$ 65	Specify <i>without arms</i> .
Gliding Seat		
• Fixed seat	-\$ 33	Specify <i>with fixed seat</i> .
Casters		
• Soft, dark grey treaded, dual-wheel roll-control casters for use on hard floors	+\$ 25	Specify <i>with soft roll-control casters</i> .

Specification Information	
Style Number	Base Price
428510	\$850

▶ Detailed dimensions, page 214

QiVi 428 Series Collaborative Stool

SIN 711.18



Standard Includes	Required to Specify
<ul style="list-style-type: none"> ▶ Need help? Product details, page 210 • 8¼" pneumatic seat-height adjustment (22" to 30¼") • Arms, if selected: 6205 black plastic to match base • Seat shell, outer back, and soft touch arm caps: plastic • Five-arm base: 6205 black plastic • QiVi Net upholstery on back • 15° pivoting backrest • Standard upholstery design on seat: Fabric price group 1 • 1" gliding seat • Adjustable foot ring: plastic color • 2"-diameter, hard-composition, dual-wheel casters: black 	<ol style="list-style-type: none"> 1 Style number 2 Plastic color number for base and foot ring 3 Plastic color number for seat shell, outer back shell, and arm caps, if selected 4 QiVi Net color number for upholstery on back 5 Fabric color number for upholstery on seat 6 Options, if selected (see below) <p>▶ See <i>Surface Materials</i>, page 432.</p>

Options	Price	Required to Specify
Surface Materials <ul style="list-style-type: none"> • Upholstery on seat • Fabric price group 1 • Fabric price group 2 • Fabric price group 3 • Fabric price group 4 • Fabric price group 5 • Fabric price group 6 • Fabric price group 7 • Fabric price group 8 • Fabric price group 9 • Fabric price group 10 • Steelcase leather upholstery • Select Surfaces leather price group 1 • Elmosoft leather upholstery • Select Surfaces leather price group 2 • Steelcase vinyl • Customer's Own Material (COM) • Customer's Own Leather (COL) 	<ul style="list-style-type: none"> No cost No cost +\$ 26 +\$ 35 +\$ 42 +\$ 51 +\$ 62 +\$ 77 +\$ 94 +\$109 +\$177 +\$177 +\$205 +\$205 No cost No cost No cost 	<ul style="list-style-type: none"> Specify fabric color number. Specify fabric color number. Specify fabric color number. Specify fabric color number. Specify fabric color number. Specify fabric color number. Specify fabric color number. Specify fabric color number. Specify fabric color number. Specify fabric color number. Specify fabric color number. Add suffix S to the style number and specify leather color number. Add suffix S to the style number and specify Select Surfaces leather price group 1. ▶ See <i>Surface Materials Reference Manual</i>. Add suffix S to the style number and specify Elmosoft leather color number. Add suffix S to the style number and specify Select Surfaces leather price group 2. ▶ See <i>Surface Materials Reference Manual</i>. Add suffix S to the style number and specify vinyl color number. ▶ See <i>Surface Materials Reference Manual</i>. Add suffix S to the style number and specify leather color number.
	Fire Code Seating (FCS) +\$ 39	Add suffix F to style number.
	Soil-retardant treatment +\$ 25	Specify <i>with soil-retardant treatment</i> .
	Sewn upholstery	
	• Sewn upholstery applied +\$ 41	Add suffix S to the style number.
Base	• Arctic white +\$ 57	Specify <i>with 7241 Arctic White</i> .
	• Platinum +\$ 57	Specify <i>with 4799 Platinum Metallic</i> .
	• Lux Coatings +\$215	Specify Lux Coatings color number.
Arms	• Armless -\$ 65	Specify <i>without arms</i> .
Gliding Seat	• Fixed seat -\$ 33	Specify <i>with fixed seat</i> .
Casters	• Soft, dark grey treaded, dual-wheel roll-control casters for use on hard floors +\$ 25	Specify <i>with soft roll-control casters</i> .

Specification Information

Style Number	Base Price
428710	\$1189

Tip: Always add suffixes in alphabetical order when specifying options to QiVi seating.

Tip: Leather and vinyl upcharges are in addition to sewn upholstery upcharge.

Tip: Fire Code Seating (FCS) option is available with certain upholstery fabric choices only.
▶ Page 462

▶ Detailed dimensions, page 214

QiVi 428 Series Sled-Base Multi-Use Chairs

SIN 711.18

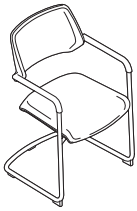

Standard Includes	Required to Specify
<ul style="list-style-type: none"> ▶ Need help? Product details, page 210 • Frame: 6205 black plastic to match base • Base, seat shell, outer back, and soft touch arm caps: plastic • QiVi Net upholstery on back • 15° pivoting backrest • Standard upholstery design on seat: fabric price group 1 • 1" gliding seat 	<ol style="list-style-type: none"> 1 Style number 2 Plastic color number for base 3 Plastic color number for, seat shell, outer back shell, and arm caps, if selected 4 QiVi Net color number for upholstery on back 5 Fabric color number for upholstery on seat 6 Options, if selected (see below) <p>▶ See <i>Surface Materials</i>, page 432.</p>

Options	Price	Required to Specify
<p>Surface Materials</p> <p>Upholstery on seat</p> <ul style="list-style-type: none"> • Fabric price group 1 No cost • Fabric price group 2 No cost • Fabric price group 3 +\$ 26 • Fabric price group 4 +\$ 35 • Fabric price group 5 +\$ 42 • Fabric price group 6 +\$ 51 • Fabric price group 7 +\$ 62 • Fabric price group 8 +\$ 77 • Fabric price group 9 +\$ 94 • Fabric price group 10 +\$109 • Steelcase leather upholstery +\$177 • Select Surfaces leather price group 1 +\$177 • Elmosoft leather upholstery +\$205 • Select Surfaces leather price group 2 +\$205 • Steelcase vinyl No cost • Customer's Own Material (COM) No cost • Customer's Own Leather (COL) No cost <p>Fire Code Seating (FCS) +\$ 39</p> <p>Soil-retardant treatment +\$ 25</p> <p>Sewn upholstery</p> <ul style="list-style-type: none"> • Sewn upholstery applied +\$ 41 		<p>Specify fabric color number.</p> <p>Specify fabric color number.</p> <p>Specify fabric color number.</p> <p>Specify fabric color number.</p> <p>Specify fabric color number.</p> <p>Specify fabric color number.</p> <p>Specify fabric color number.</p> <p>Specify fabric color number.</p> <p>Specify fabric color number.</p> <p>Specify fabric color number.</p> <p>Specify fabric color number.</p> <p>Add suffix S to the style number and specify leather color number.</p> <p>Add suffix S to the style number and specify Select Surfaces leather price group 1.</p> <p>▶ See <i>Surface Materials Reference Manual</i>. Add suffix S to the style number and specify Elmosoft leather color number.</p> <p>Add suffix S to the style number and specify Select Surfaces leather price group 2.</p> <p>▶ See <i>Surface Materials Reference Manual</i>. Add suffix S to the style number and specify vinyl color number.</p> <p>▶ See <i>Surface Materials Reference Manual</i>. Add suffix S to the style number and specify leather color number.</p> <p>Add suffix F to style number.</p> <p>Specify <i>with soil-retardant treatment</i>.</p> <p>Add suffix S to the style number.</p> <p>Specify <i>with 6009 Arctic White</i>. Specify <i>with 4799 Platinum Metallic</i>. Specify Lux Coatings color number.</p> <p>Specify <i>with fixed seat</i>.</p> <p>Specify <i>with hard glides</i>.</p> <p>Specify <i>with soft glides</i>.</p>
<p>Base</p> <ul style="list-style-type: none"> • Arctic white +\$ 57 • Platinum metallic +\$ 57 • Lux Coatings +\$125 		
<p>Gliding Seat</p> <ul style="list-style-type: none"> • Fixed seat -\$ 33 		
<p>Glides</p> <ul style="list-style-type: none"> • Hard glides for use on carpeted floors No cost • Soft glides for use on non-carpeted floors +\$ 6 		

Tip: Always add suffixes in alphabetical order when specifying options to QiVi seating.

Tip: Leather and vinyl upcharges are in addition to sewn upholstery upcharge.

Tip: Fire Code Seating (FCS) option is available with certain upholstery fabric choices only.

▶ Page 462

▶ See page 211 for a list of Lux Coatings finish numbers.

▶ Detailed dimensions, page 214

Specification Information

• Style • Number	• Base • Price
---------------------	-------------------

Sled-Base

428310	\$694
--------	-------

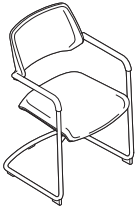

Stacking Sled-Base

428910	\$694
--------	-------

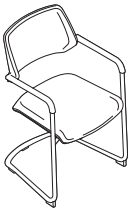

cobi 434 Series

cobi is collaborative seating for teams that helps people move freely, change postures, and stay energized and comfortable.

Flexing fingers in back offer support while moving and conforming to the user.

Weight-activated mechanism provides support by automatically responding to the users movements.

Five-arm base is standard.

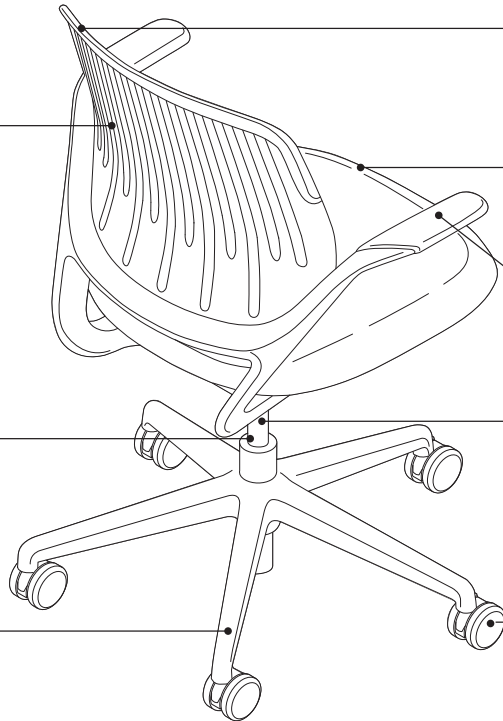

Flexible top edge allows for multiple postures while maintaining support and comfort.

Flexible seat edge on all 3-sides supports multiple postures while relieving thigh pressure.

Arms are constructed of a soft durable rubber compound.

Seat height adjusts with a 5" range from 15½"H to 20½"H with a pneumatic adjustment mechanism.

Casters have hard, dual-wheels that roll smoothly on carpets. They are 2½" for increased mobility. Soft, dual-wheel casters are available for use on hard floors or chair mats. Stools are standard with 2" hard casters. Soft casters are available as an option.
Tip: Do not roll the chair across asphalt during installation as this may damage the casters.

Product Details



Chairs and stools are available with or without arms.



Weight-activated mechanism provides individual support without a tension control by intuitively sensing and supporting the users center of gravity.

cobi ships standard assembled and uncartoned. A cartoned version is available which ships unassembled with the chair seat, back, and cylinder separated from the base and mechanism. This allows for shipment in a smaller carton. Assembly by a qualified dealer installer is required. Assembly instructions are included.

Adjustment Features

Seat Adjustments

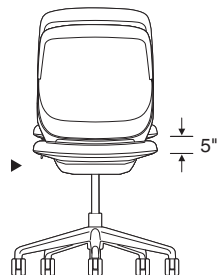

Seat height adjusts pneumatically. To lower, pull lever up while seated. To raise, pull lever up and keep your weight off the chair.

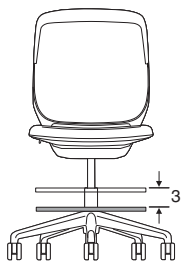

Foot ring height on stools adjusts by first lifting ring and rotating it counter-clockwise to unlock. Then raise or lower ring up to 4" to desired position before rotating it clockwise to lock. The foot ring has a diameter of 20".

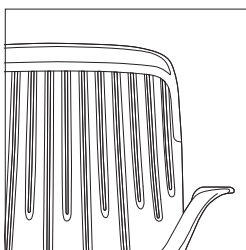

Flexing fingers in back promote movement and provide support for a wide range of postures.

Soft roll-control caster option features an internal brake that activates when the chair is not under load to reduce shifting when user stands up.

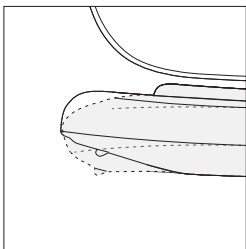

Flexing seat edge on all 3-sides supports multiple postures while relieving thigh pressure.

Surface Materials

▶ See surface materials on page 432 for specific availability or refer to the *Surface Materials Reference Manual* for further information.

Back Upholstery

- Connect 3D (back only)

Seat Upholstery

- Cogent: Connect (seat only)
- Fabric
- Fabric with soil-retardant treatment (option)
- Leather
- ElmoSoft leather
- Select Surfaces leather
- Vinyl
- COM
- COL

All seat upholstery except standard Cogent: Connect requires a sewn application. Specify with an **S** suffix.

Outer Back

- 6009 Arctic White
- 6205 Black
- 6249 Platinum
- 6295 Near Black

Arm Caps, Top Edge, and Casters

- 6205 Black
- 6249 Platinum

Tip: Frame, base, and cylinder will default to match outer back color.

Tip: Arm caps, top edge, and casters will coordinate to match outer back color.

Glides

- Black plastic

Foot ring on stools

- 6205 Black
- 6249 Platinum

Tip: Foot ring on stool will coordinate to match outer back color.

All Steelcase seating with standard upholstery fabrics

complies with requirements of the State of California Technical Bulletin 117-2013. All standard seating is labeled to be in compliance with California 117-2013.

Programs & Services

▶ See the *Surface Materials Reference Manual* for further detail about programs and services offered for seating.

The Customer's Own Material (COM) Program

offers the opportunity for customers to select fabrics that are not offered through the standard Steelcase surface materials program for use on Steelcase products. Through the COM program, Steelcase will test your materials for application on Steelcase products. Once approved, you can place your order. Steelcase will facilitate the entire ordering process and give you a production schedule. Steelcase will order the COM fabric directly from the textile manufacturer. For up-to-date information regarding fabric test results for all COM fabrics and details regarding yardage requirements for most Seating lines, visit the COM website. To locate the COM website:

- Visit www.steelcase.com

Soil retardants are treatments that provide long-term soil and stain resistance to a fabric without affecting the shade or the integrity of the fabric. The following Steelcase Textiles are available pre-treated with soil retardant. (You do not need to select the soil-retardant option for these fabrics and incur the upcharge.)

- Jacks
- Link
- Spyder

For information on soil retardant fabrics on Select Surfaces, please refer to the *Surface Materials Reference Manual*.

Soil-retardant treatment is available on all other seating fabrics at an additional upcharge per seating unit. To order this option, please select "Soil-Retardant Treatment" under "Optional Accessories."

For soil-retardant treatment on COMs, please select "Soil-Retardant Treatment" under "Optional Accessories." Minimums or additional yardage may be required. Please contact the vendor directly for specific information.

Extended lead times may be necessary for this service.

Contact your Steelcase Solutions Fulfillment Team Representative at 1.888.STEELCASE (1.888.783.3522) or send an email to lineone@steelcase.com.

Fire Codes

▶ See pages 462 for upholstery fabrics available for use with FCS modification.

Steelcase offers Fire Code Seating modification (FCS) on some seating models. The most rigorous fire codes in the nation have been developed in California, and the Steelcase FCS modification is designed to meet those codes. Fire Code Seating (FCS) indicates that a product is constructed to meet the strict fire code requirements of high public occupancy areas such as theaters, meeting rooms, and lobbies. The FCS standards will meet the State of California Bureau of Electronic and Appliance Repair, Home Furnishings, and Thermal Insulation Technical Bulletin 133 (Cal TB 133). Boston adopted the California Bureau of Electronic and Appliance Repair, Home Furnishings, and Thermal Insulation Technical Bulletin TB 133 test standard in 1992.

Local codes may have special requirements for upholstery.

Dimensions

▶ Page 222

Resources

Printed Materials

- ▶ cobi Brochure (09-0000049)
- ▶ cobi User Guide (10-0002706)

Online Resources

- ▶ Come Together (PDF) available on www.steelcase.com
- ▶ Collaborative Seating Design video available on www.steelcase.com
- ▶ Environmental profiles available on www.steelcase.com/sustainability

Dimensions

cobi 434 Series

Features	Overall Depth	Width	Height	Seat Depth	Functional Seat Depth	Seat Width	Seat Height from Floor	Ring Height from Floor	Back Width	Back Height from Seat
cobi 434 Series										
Collaborative Chairs										
	23 ¹ / ₄ "	24 ³ / ₄ "	34"-39"	19 ¹ / ₂ "	17 ⁷ / ₈ "	18 ³ / ₄ "	15 ¹ / ₂ "-20 ¹ / ₂ "	N.A.	18"	19 ¹ / ₂ "
Stools										
	23 ¹ / ₄ "	24 ³ / ₄ "	40"-50"	19 ¹ / ₂ "	17 ⁷ / ₈ "	18 ³ / ₄ "	21"-31"	11 ¹ / ₄ "-14 ¹ / ₄ "	18"	19 ¹ / ₂ "

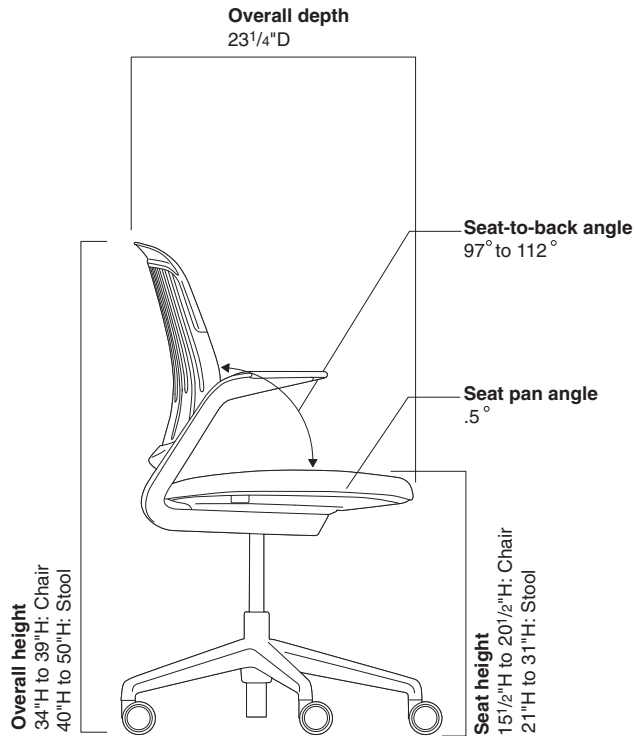
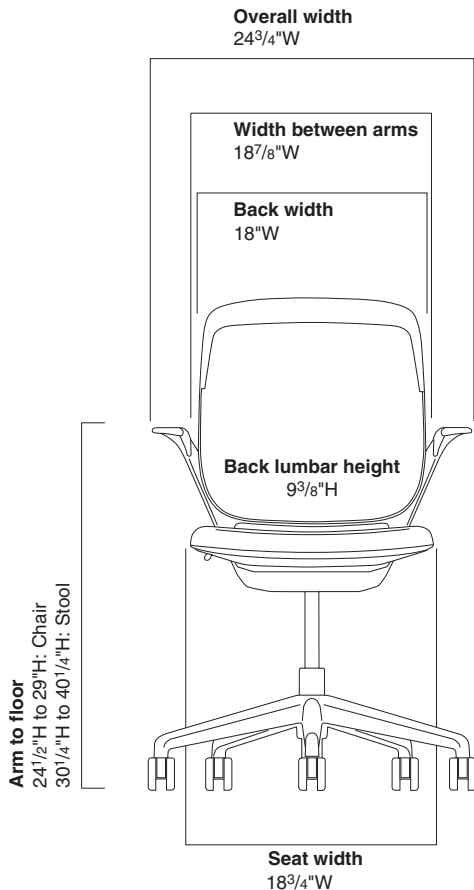

• Back Lumbar Height	• Width Between Arms	• Arm to Floor	• Arm Height from Seat	• Seat Pan Angle	• Angle Between Seat and Back
----------------------	----------------------	----------------	------------------------	------------------	-------------------------------

Collaborative Chairs

9 ³ / ₈ "	18 ⁷ / ₈ "	24 ¹ / ₄ "–29"	8 ⁷ / ₈ "	.5°	97°–112°
---------------------------------	----------------------------------	--------------------------------------	---------------------------------	-----	----------

Stools

9 ³ / ₈ "	18 ⁷ / ₈ "	30 ¹ / ₄ "–40 ¹ / ₄ "	8 ⁷ / ₈ "	.5°	97°–112°
---------------------------------	----------------------------------	---	---------------------------------	-----	----------

cobi 434 Series Collaborative Chairs

SIN 711.18



Standard Includes	Required to Specify
<ul style="list-style-type: none"> ▶ Need help? Product details, page 220 • Weight-activated mechanism • 5" pneumatic seat-height adjustment • Fixed arms, if selected: plastic to match outer back • Back upholstery: Connect 3D • Seat upholstery: Cogent: Connect • Frame, outer back, and five-arm base: Black • 2½"-diameter, hard composition, dual-wheel casters: black plastic 	<ol style="list-style-type: none"> 1 Style number 2 Plastic color number for outer back 3 Connect 3D color number for back 4 Cogent: Connect color number for upholstery on seat 5 Options, if selected (see below) <p>▶ See <i>Surface Materials</i>, page 432.</p>

*Tip: All seat upholstery except standard Cogent: Connect requires a sewn application. Specify with an **S** suffix.*

Tip: Always add suffixes in alphabetical order when specifying options to cobi seating.

Tip: Leather and vinyl upcharges are in addition to sewn upholstery upcharge.

Tip: Fire Code Seating (FCS) option is available with certain upholstery fabric choices only.

▶ Pages 462

Tip: Arm caps, top edge, and casters default to coordinate and match outer back color.

▶ Detailed dimensions, page 222

Options	Price	Required to Specify					
<table border="0"> <tr> <td style="background-color: #212121; color: white; vertical-align: top;">Surface Materials</td> <td style="background-color: #212121; color: white; vertical-align: top;">Upholstery</td> <td></td> </tr> <tr> <td></td> <td> <ul style="list-style-type: none"> • Fabric price group 1 • Fabric price group 2 • Fabric price group 3 • Fabric price group 4 • Fabric price group 5 • Fabric price group 6 • Fabric price group 7 • Fabric price group 8 • Fabric price group 9 • Fabric price group 10 • Steelcase leather upholstery • Select Surfaces leather price group 1 • Elmosoft leather upholstery • Select Surfaces leather price group 2 • Steelcase vinyl • Customer's Own Material (COM) • Customer's Own Leather (COL) </td> <td> <p>No cost</p> <p>No cost</p> <p>+\$ 26</p> <p>+\$ 35</p> <p>+\$ 42</p> <p>+\$ 51</p> <p>+\$ 62</p> <p>+\$ 77</p> <p>+\$ 94</p> <p>+\$109</p> <p>+\$177</p> <p>+\$177</p> <p>+\$205</p> <p>+\$205</p> <p>No cost</p> <p>No cost</p> <p>No cost</p> </td> </tr> </table>	Surface Materials	Upholstery			<ul style="list-style-type: none"> • Fabric price group 1 • Fabric price group 2 • Fabric price group 3 • Fabric price group 4 • Fabric price group 5 • Fabric price group 6 • Fabric price group 7 • Fabric price group 8 • Fabric price group 9 • Fabric price group 10 • Steelcase leather upholstery • Select Surfaces leather price group 1 • Elmosoft leather upholstery • Select Surfaces leather price group 2 • Steelcase vinyl • Customer's Own Material (COM) • Customer's Own Leather (COL) 	<p>No cost</p> <p>No cost</p> <p>+\$ 26</p> <p>+\$ 35</p> <p>+\$ 42</p> <p>+\$ 51</p> <p>+\$ 62</p> <p>+\$ 77</p> <p>+\$ 94</p> <p>+\$109</p> <p>+\$177</p> <p>+\$177</p> <p>+\$205</p> <p>+\$205</p> <p>No cost</p> <p>No cost</p> <p>No cost</p>	<p>Add suffix S to the style number and specify fabric color number.</p> <p>Add suffix S to the style number and specify fabric color number.</p> <p>Add suffix S to the style number and specify fabric color number.</p> <p>Add suffix S to the style number and specify fabric color number.</p> <p>Add suffix S to the style number and specify fabric color number.</p> <p>Add suffix S to the style number and specify fabric color number.</p> <p>Add suffix S to the style number and specify fabric color number.</p> <p>Add suffix S to the style number and specify fabric color number.</p> <p>Add suffix S to the style number and specify fabric color number.</p> <p>Add suffix S to the style number and specify fabric color number.</p> <p>Add suffix S to the style number and specify fabric color number.</p> <p>Add suffix S to the style number and specify leather color number.</p> <p>Add suffix S to the style number and specify Select Surfaces leather price group 1.</p> <p>▶ See <i>Surface Materials Reference Manual</i>. Add suffix S to the style number and specify Elmosoft leather color number.</p> <p>Add suffix S to the style number and specify Select Surfaces leather price group 2.</p> <p>▶ See <i>Surface Materials Reference Manual</i>. Add suffix S to the style number and specify vinyl color number.</p> <p>▶ See <i>Surface Materials Reference Manual</i> to specify.</p> <p>Add suffix S to the style number and specify leather color number.</p>
Surface Materials	Upholstery						
	<ul style="list-style-type: none"> • Fabric price group 1 • Fabric price group 2 • Fabric price group 3 • Fabric price group 4 • Fabric price group 5 • Fabric price group 6 • Fabric price group 7 • Fabric price group 8 • Fabric price group 9 • Fabric price group 10 • Steelcase leather upholstery • Select Surfaces leather price group 1 • Elmosoft leather upholstery • Select Surfaces leather price group 2 • Steelcase vinyl • Customer's Own Material (COM) • Customer's Own Leather (COL) 	<p>No cost</p> <p>No cost</p> <p>+\$ 26</p> <p>+\$ 35</p> <p>+\$ 42</p> <p>+\$ 51</p> <p>+\$ 62</p> <p>+\$ 77</p> <p>+\$ 94</p> <p>+\$109</p> <p>+\$177</p> <p>+\$177</p> <p>+\$205</p> <p>+\$205</p> <p>No cost</p> <p>No cost</p> <p>No cost</p>					
	<p>Fire Code Seating (FCS) +\$108</p> <p>Soil-retardant treatment +\$ 25</p>	<p>Add suffix F to style number.</p> <p>Specify with <i>soil-retardant treatment</i>.</p>					
	<p>Sewn upholstery</p> <ul style="list-style-type: none"> • Sewn upholstery applied +\$ 41 	<p>Add suffix S to the style number.</p>					
	<p>Outer back</p> <ul style="list-style-type: none"> • Arctic white +\$ 86 • Platinum +\$ 86 • Near black +\$ 86 	<p>Specify with <i>6009 Arctic White</i>.</p> <p>Specify with <i>6249 Platinum</i>.</p> <p>Specify with <i>6295 Near Black</i>.</p>					
Casters	<ul style="list-style-type: none"> • Soft, dark grey treaded, dual-wheel roll-control casters for use on hard floors +\$ 25 	<p>Specify with <i>soft roll-control casters</i>.</p>					
Glides	<ul style="list-style-type: none"> • Glides: plastic +\$ 25 	<p>Specify with <i>glides</i>.</p>					

Specification Information

**Arms with
Soft Arm Caps**



• Style • Number	• Base • Price
434111	\$758
.	.

Without Arms



• Style • Number	• Base • Price
434110	\$699
.	.

cobi 434 Series Swivel-Base Stools

SIN 711.18

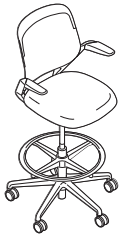

Tip: All seat upholstery except standard Cogent: Connect requires a sewn application. Specify with an S suffix.

Tip: Always add suffixes in alphabetical order when specifying options to cobi seating.

Tip: Leather and vinyl upcharges are in addition to sewn upholstery upcharge.

Tip: Fire Code Seating (FCS) option is available with certain upholstery fabric choices only.
▶ Pages 462

Tip: Arm caps, top edge, casters, and stool ring default to coordinate and match outer back color.

Standard Includes	Required to Specify
<ul style="list-style-type: none"> ▶ Need help? Product details, page 220 • Weight-activated mechanism • 10" pneumatic seat-height adjustment • Fixed arms, if selected: plastic to match outer back • Adjustable foot ring: black • Back upholstery: Connect 3D • Seat upholstery: Cogent: Connect • Frame, outer back, and five-arm base: black • 2½"-diameter, hard composition, dual-wheel casters: black plastic 	<ol style="list-style-type: none"> 1 Style number 2 Plastic color number for outer back 3 Connect 3D color number for back 4 Cogent: Connect color number for upholstery on seat 5 Options, if selected (see below) <p>▶ See <i>Surface Materials</i>, page 432.</p>

Options	Price	Required to Specify
<p>Surface Materials</p> <ul style="list-style-type: none"> • Upholstery • Fabric price group 1 • Fabric price group 2 • Fabric price group 3 • Fabric price group 4 • Fabric price group 5 • Fabric price group 6 • Fabric price group 7 • Fabric price group 8 • Fabric price group 9 • Fabric price group 10 • Steelcase leather upholstery • Select Surfaces leather price group 1 • Elmosoft leather upholstery • Select Surfaces leather price group 2 • Steelcase vinyl • Customer's Own Material (COM) • Customer's Own Leather (COL) 	<ul style="list-style-type: none"> No cost No cost +\$ 26 +\$ 35 +\$ 42 +\$ 51 +\$ 62 +\$ 77 +\$ 94 +\$109 +\$177 +\$177 +\$205 +\$205 No cost No cost No cost 	<p>Add suffix S to the style number and specify fabric color number.</p> <p>Add suffix S to the style number and specify fabric color number.</p> <p>Add suffix S to the style number and specify fabric color number.</p> <p>Add suffix S to the style number and specify fabric color number.</p> <p>Add suffix S to the style number and specify fabric color number.</p> <p>Add suffix S to the style number and specify fabric color number.</p> <p>Add suffix S to the style number and specify fabric color number.</p> <p>Add suffix S to the style number and specify fabric color number.</p> <p>Add suffix S to the style number and specify fabric color number.</p> <p>Add suffix S to the style number and specify fabric color number.</p> <p>Add suffix S to the style number and specify fabric color number.</p> <p>Add suffix S to the style number and specify leather color number.</p> <p>Add suffix S to the style number and specify Select Surfaces leather price group 1.</p> <p>▶ See <i>Surface Materials Reference Manual</i>. Add suffix S to the style number and specify Elmosoft leather color number.</p> <p>Add suffix S to the style number and specify Select Surfaces leather price group 2.</p> <p>▶ See <i>Surface Materials Reference Manual</i>. Add suffix S to the style number and specify vinyl color number.</p> <p>▶ See <i>Surface Materials Reference Manual</i> to specify.</p> <p>Add suffix S to the style number and specify leather color number.</p>
<p>Fire Code Seating (FCS)</p>	<p>+\$108</p>	<p>Add suffix F to style number.</p>
<p>Soil-retardant treatment</p>	<p>+\$ 25</p>	<p>Specify with <i>soil-retardant treatment</i>.</p>
<p>Sewn upholstery</p> <ul style="list-style-type: none"> • Sewn upholstery applied 	<p>+\$ 41</p>	<p>Add suffix S to the style number.</p>
<p>Outer back</p> <ul style="list-style-type: none"> • Arctic white • Platinum • Near black 	<p>+\$132</p> <p>+\$132</p> <p>+\$132</p>	<p>Specify with <i>6009 Arctic White</i>.</p> <p>Specify with <i>6249 Platinum</i>.</p> <p>Specify with <i>6295 Near Black</i>.</p>

▶ Options, continued on next page

▶ Detailed dimensions, page 222

► Options, continued from previous page

Options	Price	Required to Specify
Casters <ul style="list-style-type: none"> Soft, dark grey treaded, dual-wheel roll-control casters for use on hard floors 	+\$25	Specify with soft roll-control casters.
Glides <ul style="list-style-type: none"> Glides: plastic 	+\$25	Specify with glides.

Specification Information

Arms with Soft Arm Caps



Style Number	Base Price
434711	\$1058

Without Arms



Style Number	Base Price
434710	\$999

Node 480 Series

Node is a collaborative seating line that accommodates multiple environments including classrooms, clinical settings, and other learning environments. Node supports multiple teaching and learning modes, freedom to change postures, and optional storage.

One piece polypropylene contoured shell is designed for easy maintenance and cleaning.

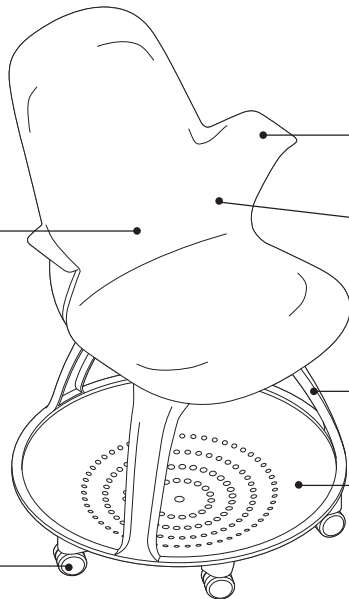

Arms are designed to support arms, side-sitting postures, and serve as a backpack hook.

Flexible and contoured seat shell supports comfort by allowing many postures.

360°-swivel mechanism is standard.

Backpack storage area is standard.

Casters have hard, dual wheels that roll smoothly on carpets. Soft dual-wheel casters are available for use on hard floors.

Tip: Do not roll the chair across asphalt during installation as this may damage the casters.

Personal worksurface moves independently of seat shell and base.

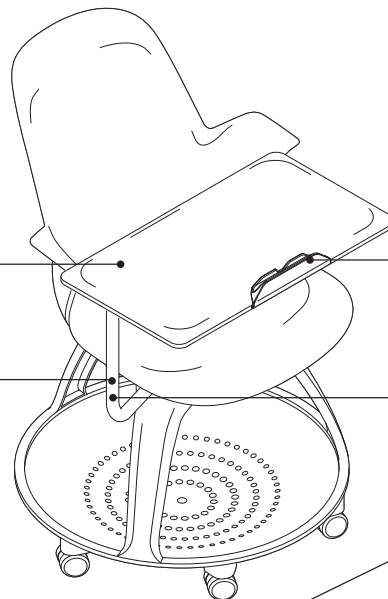

Tablet stand is available on all personal worksurfaces and supports tablets and smart phones.

Personal worksurface is depth adjustable for large and small users and allows for ingress/egress.

Personal worksurface is mounted on the right but appropriate for both right- and left-hand users.

ShareSurface is designed to support collaboration with its uniquely designed surface that pivots and rotates 360°.

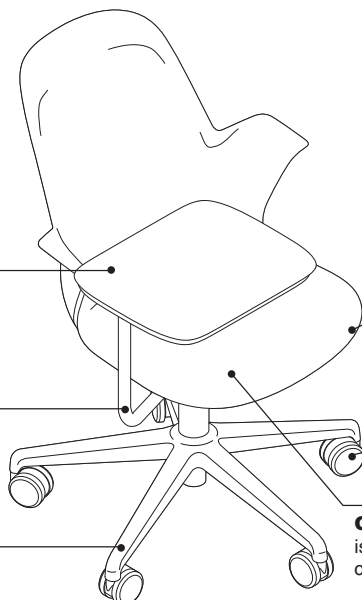

Seat height adjusts with a 5¼" range with a pneumatic adjustment mechanisms on five-arm base chairs. Chairs with a personal worksurface or Share-Surface adjusts with a 4" range. Stools have a 8½" range. A 7½" range is available as an option.

ShareSurface is non-handed and swings from right to left to optimize sharing technology.

Hard, dual wheel casters are standard for use on carpets. Soft, roll-control dual-wheel casters are available for use on hard floors or chair mats.
Tip: Do not roll the chair across asphalt during installation as this may damage the casters.

Five-arm base is standard.

Optional seat cushion is available for extended comfort.

Product Details

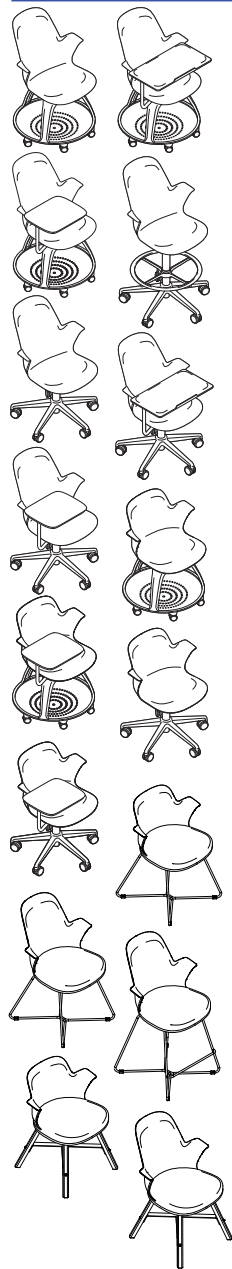

Chairs and stools are available with high-back and mid-back shells. Chairs are available with a tripod base, tripod base with personal workspace or ShareSurface, five-arm base with pneumatic adjustment, and five-arm base with pneumatic adjustment with personal workspace or ShareSurface. Stools are available with five-arm base only.

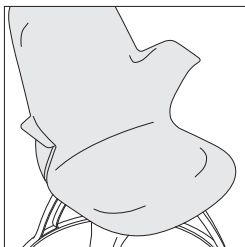

Flexing seat shell and arms promotes movement and supports multiple postures. Integrated arms support user's arms, side posture, and act as a backpack hook.

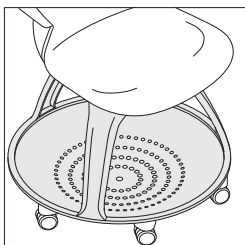

Tripod base reclaims the space under the seat. The space is 1.7 cu/ft. and allows for backpacks or personal belongings to be stored, and serves as a footrest.

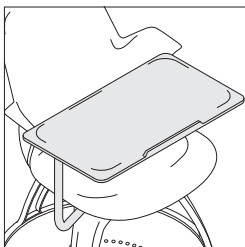

Personal workspace is mounted on user's right, and designed to accommodate left- and right-handed users. It is 12"D x 22 1/4"W and features a safety stop to help prevent belongings and laptops from easily sliding off back edge. It is designed to be level when in use and may appear to have a slight upward angle when not in use.

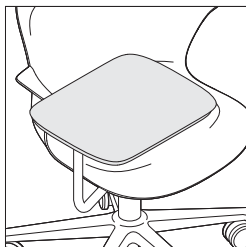

ShareSurface is mounted to the underside of the seat and moves from right to left at 138° to accommodate left- and right-handed users. The ShareSurface is 12"D x 14 1/2"W. The surface swivels 360° around a 1 1/2" pivot to maximize comfort and collaboration.

Node tripod, with or without workspace, and Node five-arm base chairs with workspace ships standard unassembled and cartoned with the seat shell separated from the base. This allows for shipment in a smaller carton. Five-arm base chairs without workspace and stools ship two to a carton. Assembly by a qualified Steelcase dealer installer is required. Assembly instructions are available at www.steelcase.com. No tools required for assembly.

Adjustment Features

360° fixed height swivel mechanism on tripod base models allows students to remain oriented to instructor, presentation materials, and other students.

360° adjustable height swivel mechanism is standard on five-arm base models.

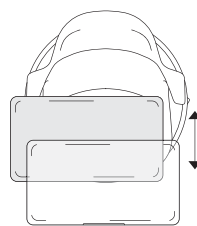

Personal workspace depth adjustment range is 7 1/4" to 15". Measurement is from lumbar to workspace.

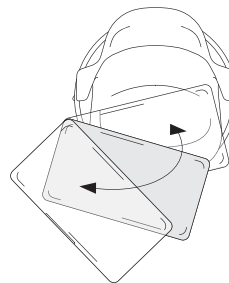

Personal workspace pivot range is 48°.

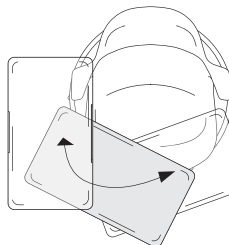

Personal workspace center pivot is 100°. The center pivot range is measured from the closest position to the furthest position from the user.

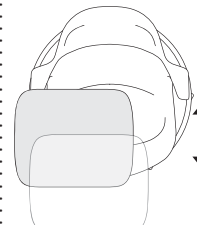

ShareSurface depth adjustment range is 11 1/4" to 16 5/8". Measurement is from lumbar to worksurface.

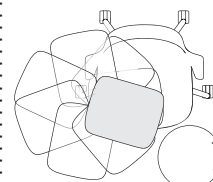

ShareSurface swivels 360° around a 1 1/2" pivot for inputting data or sharing information.

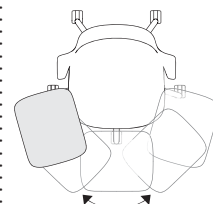

ShareSurface arm swings right to left at 138°. The two-pivot mechanism for the surface allows the surface to pivot right to left, allowing users to collaborate or move the surface out of the way for easy ingress and egress.

Node 480 Series, continued

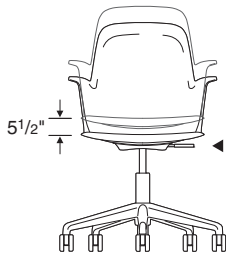

Seat height adjusts pneumatically. To lower, pull lever up while seated. To raise, pull lever up and keep your weight off the chair. Range of adjustability is 5¹/₄" from 16"H to 21³/₁₆"H, a 3³/₄" range (17¹/₈"H to 20³/₄"H) is available on chairs with a worksurface. Stools are standard with an 8¹/₂" range of adjustability (23¹/₁₆"H to 31³/₈"H). A 7¹/₂" range of adjustability (18¹/₂"H to 26⁷/₁₆"H) is available as an option.

Glides are available as an option. Glides ship assembled on the chair or stool and maintain same height as casters.

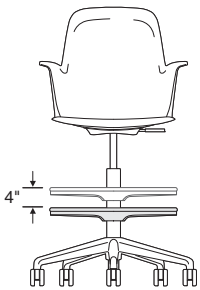

Foot ring height on stools adjusts by first lifting ring and rotating it counterclockwise to unlock. Then raise or lower ring up to 4" to desired position before rotating it clockwise to lock. The foot ring has a diameter of 20".

Soft, dual-wheel roll-control casters for hard floors are available on five-arm base chairs and stools only.

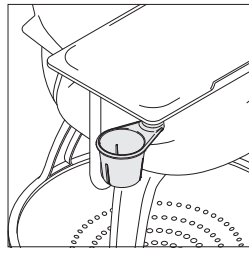

Cup holder is available as an option on Node chairs with personal worksurfaces. It is retractable under the worksurface when not in use. *Tip: Cup holder is not available on Node chairs with ShareSurface.*

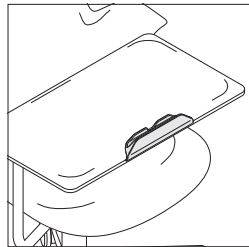

Tablet stand is available on Node chairs with personal worksurfaces. The stand supports tablets and smart phones in both portrait and landscape positions, making content easy to view and freeing up space on the worksurface for other materials. It can be field or factory installed. *Tip: Devices are not secure in tablet stand when Node is moved.*

Surface Materials

▶ See surface materials on page 432 for specific availability or refer to the *Surface Materials Reference Manual* for further information.

Seat Shell

Price Group 1

- Plastics
- 6009 Arctic White
- 6059 Sterling Dark Solid
- 6205 Black
- 6249 Platinum Solid
- 6259 Midnight
- 6332 Citron
- 6333 Picasso
- 6334 Flash
- 6335 Wasabi
- 6336 Jazz
- 6337 Element
- 6338 Chili
- 6BD8 Snow
- 6BD9 Carbon Flat
- 6BE1 Ore

Price Group 2

- Signature Plastics
- 6BD1 Aubergine
- 6BD2 Peacock
- 6BD3 Jungle
- 6BD4 Merlot
- 6BD5 Honey
- 6BD6 Lagoon
- 6BD7 Saffron

Tripod Base

- 6249 Platinum Solid
- 6295 Near Black
- 6337 Element

Five-arm Base

- 6205 Black
- 6249 Platinum Solid
- 6337 Element

Personal Worksurface and ShareSurface

- 6053 Seagull
- 6249 Platinum Solid
- 6295 Near Black
- 6337 Element
- 6654 Sand

Paint for Metal

- 0835 Black
- 4750 Champagne Metallic
- 4799 Platinum Metallic

Casters

- Black

Glides

- Black plastic (five-arm base)
- Sterling Dark Solid (tripod base)

Cup Holder

- Sterling Dark Solid

Tablet Stand

- Sterling Dark Solid

Seat Cushion

- Upholstery
- Leather
- Elmosoft Leather
- Select Surface Leather
- COM (Customer's Own Material)
- COL (Customer's Own Leather)

Fire Code Seating (FCS) option is available.

▶ See *Surface Materials*, page 462.

Steelcase offers Fire Code Seating modification (FCS) on some seating models.

The most rigorous fire codes in the nation have been developed in California, and the Steelcase FCS modification is designed to meet those codes. Fire Code Seating (FCS) indicates that a product is constructed to meet the strict fire code requirements of high public occupancy areas such as theaters, meeting rooms, and lobbies. The FCS standards will meet the State of California Bureau of Electronic and Appliance Repair, Home Furnishings, and Thermal Insulation Technical Bulletin 133 (Cal TB 133). Boston adopted the California Bureau of Electronic and Appliance Repair, Home Furnishings, and Thermal Insulation Technical Bulletin TB 133 test standard in 1992.

Dimensions

▶ Page 232

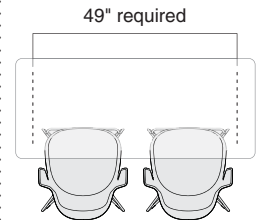

The backpack storage area and overall chair width require 23³/₄" of continuous floor space when used with tables. The minimum distance between table bases is 49" to allow two chairs to be pushed under the worksurface. This does not apply to five-arm base models.

Resources

Printed Materials

▶ Node Brochure (10-0002733)

Online Resources

- ▶ Node Higher Ed Classroom Case Study available at www.steelcase.com
- ▶ Node High School Classroom Case Study available at www.steelcase.com
- ▶ Indiana University Node video available at www.steelcase.com
- ▶ Node Student video available at www.steelcase.com
- ▶ Environmental profiles available on www.steelcase.com/sustainability

Dimensions

Node 480 Series

Features	Overall Depth	Width	Height	Seat Depth	Seat Width	Seat Height from Floor	Ring Height from Floor	Width Between Arms
Node 480 Series								
Tripod Base Collaborative Chair								
	25"	23 ³ / ₄ "	35"	16 ¹ / ₂ "	19 ¹ / ₂ "	18 ¹ / ₄ "	N.A.	20 ¹ / ₈ "
Five-Arm Base Collaborative Chair								
	24 ³ / ₄ "	25 ³ / ₄ "	32 ⁵ / ₈ " to 37 ³ / ₄ "	16 ¹ / ₂ "	19 ¹ / ₂ "	15 ⁵ / ₈ " to 20 ³ / ₄ "	N.A.	20 ¹ / ₈ "
Tripod Base Mid-Back Collaborative Chair								
	23 ³ / ₄ "	23 ³ / ₄ "	31 ¹ / ₄ "	15 ¹ / ₂ "	19 ¹ / ₄ "	18 ¹ / ₄ "	N.A.	20 ¹ / ₈ "
Five-Arm Base Mid-Back Collaborative Chair								
	23 ¹ / ₂ "	25 ³ / ₄ "	28 ⁷ / ₈ " to 34"	15 ¹ / ₂ "	19 ¹ / ₄ "	15 ⁵ / ₈ " to 20 ³ / ₄ "	N.A.	20 ¹ / ₈ "
Five-Arm Base Stool								
	24 ³ / ₄ "	25 ³ / ₄ "	40 ⁷ / ₈ " to 48 ¹ / ₄ "	16 ¹ / ₂ "	19 ¹ / ₂ "	23 ⁵ / ₈ " to 31 ³ / ₈ "	11 ¹ / ₂ " to 15 ¹ / ₂ "	20 ¹ / ₈ "
Five-Arm Base Mid-Back Stool								
	23 ¹ / ₂ "	25 ³ / ₄ "	37 ¹ / ₈ " to 44 ¹ / ₂ "	15 ¹ / ₂ "	19 ¹ / ₄ "	23 ⁵ / ₈ " to 31 ³ / ₈ "	11 ¹ / ₂ " to 15 ¹ / ₂ "	20 ¹ / ₈ "

*Personal worksurface height from floor on tripod base chairs is 28¹/₂".

*Personal worksurface height from floor on five-arm base chairs is 27³/₁₆" to 30¹³/₁₆".

*Personal worksurface measures 22¹/₂"W x 12"D and has a depth adjustment range of 7¹/₄" to 15".

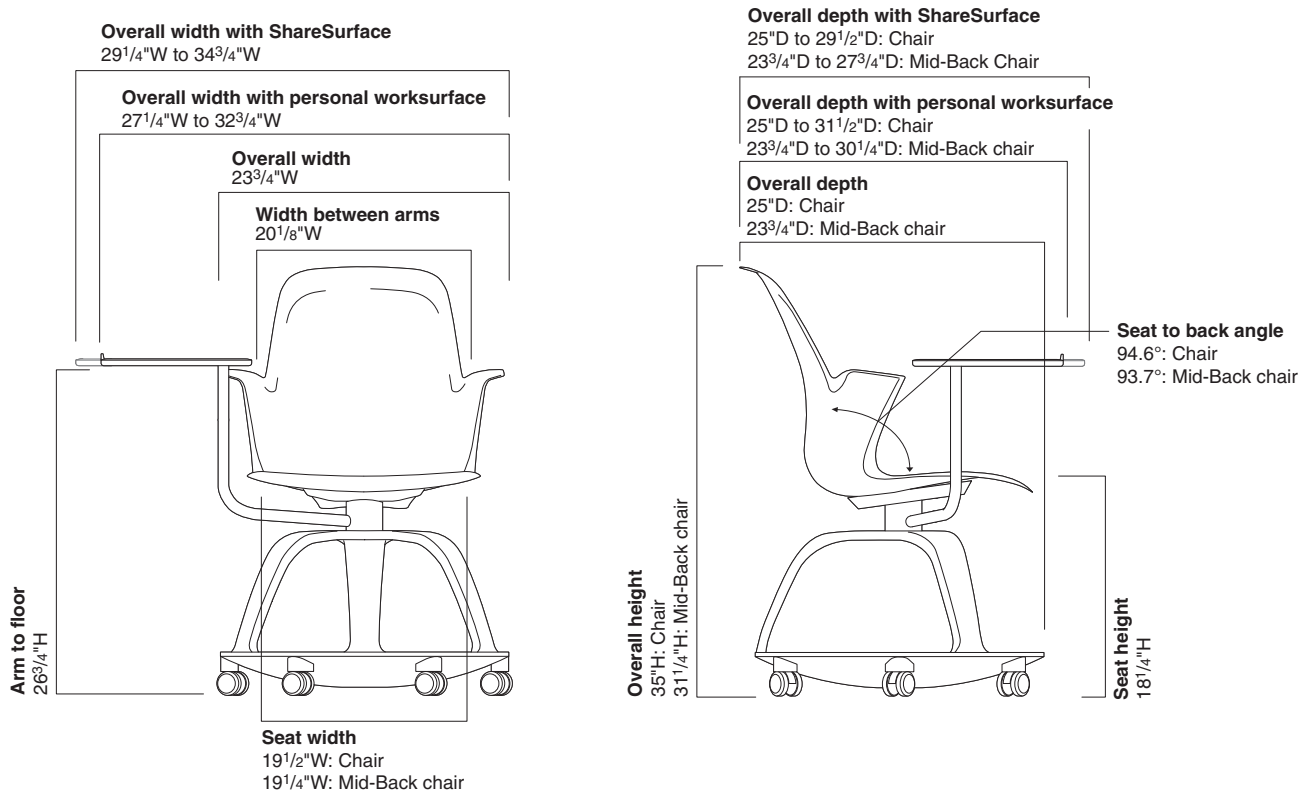

· Arm
to
Floor
· Angle
Between
Seat and
Back

Tripod Base Collaborative Chair

26³/₄" 94.6°

Five-Arm Base Collaborative Chair

24¹/₈" to 29¹/₄" 94.6°

Tripod Base Mid-Back Collaborative Chair

26³/₄" 93.7°

Five-Arm Base Mid-Back Collaborative Chair

24¹/₈" to 29¹/₄" 93.7°

Five-Arm Base Stool

27" to 35" 94.6°

Five-Arm Base Mid-Back Stool

27" to 35" 93.7°

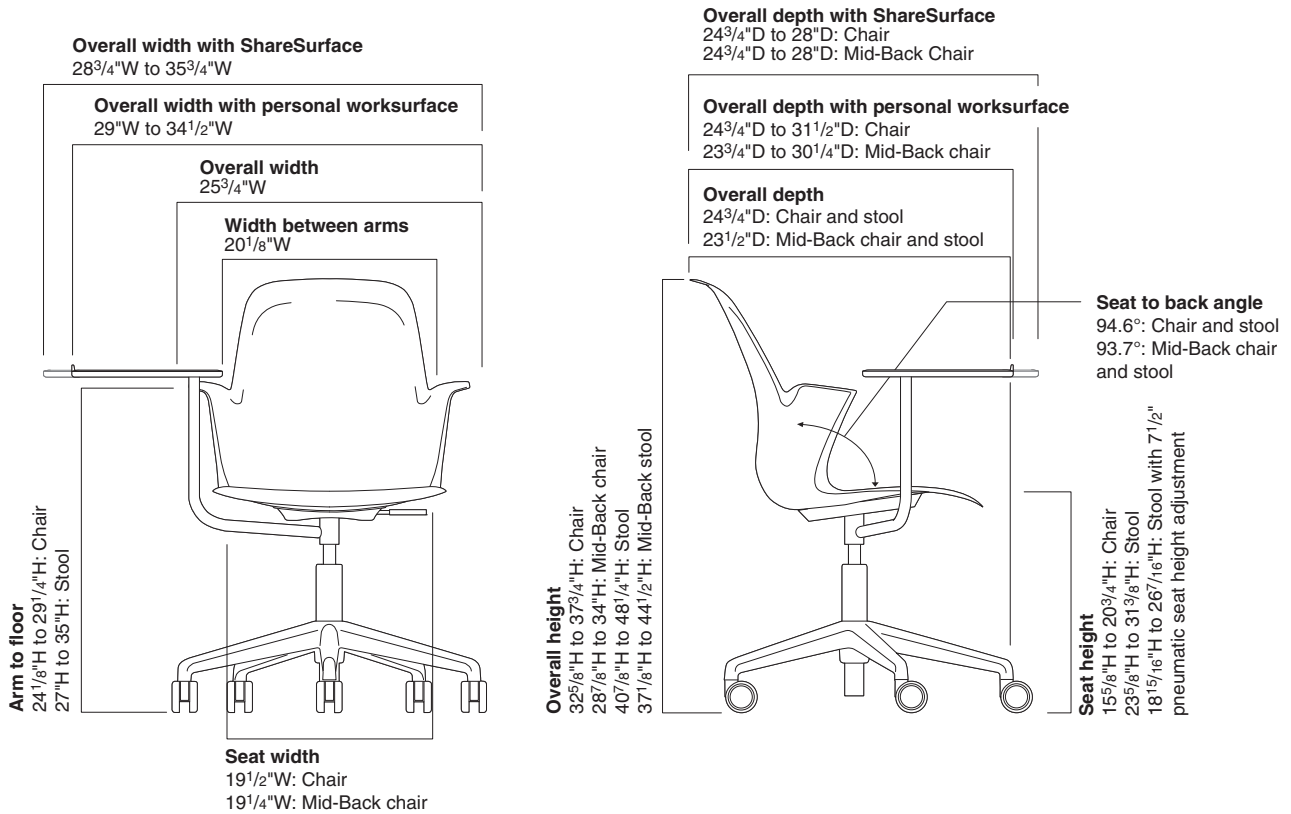

Node 480 Series Collaborative Chairs

With Tripod Base

SIN 711.18



Standard Includes	Required to Specify
<ul style="list-style-type: none"> ▶ Need help? Product details, page 228 • Seat shell: plastic • Tripod base: plastic • Storage tray: sterling dark solid • Metal components: 0835 Black paint • Swivel seat • Worksurface, if selected: plastic • Hard casters 	<ol style="list-style-type: none"> 1 Style number 2 Plastic color number for seat shell 3 Plastic color number for tripod base 4 Paint color number for metal components 5 Plastic color number for personal worksurface, if selected 6 Options, if selected (see below) <p>▶ See <i>Surface Materials</i>, page 432.</p>

Options	Price	Required to Specify	
Surface Materials			
Platinum or Champagne Metallic metal components			
• On 480110 and 480170	+\$ 10	Specify with 4799 Platinum or 4750 Champagne Metallic.	
• On 480120	+\$ 24	Specify with 4799 Platinum or 4750 Champagne Metallic.	
Seat shell			
• Plastic price group 1	No cost	Specify color number. ▶ See <i>Surface Materials</i> , page 432.	
• Plastic price group 2	+\$ 28	Specify color number. ▶ See <i>Surface Materials</i> , page 432.	
• Fire Code Seating (FCS)	+\$ 80	Add suffix F to style number.	
Cushion			
• Price group 1	No cost	Specify fabric color number.	
• Price group 2	+\$ 10	Specify fabric color number.	
• Price group 3	+\$ 27	Specify fabric color number.	
• Price group 4	+\$ 36	Specify fabric color number.	
• Price group 5	+\$ 43	Specify fabric color number.	
• Price group 6	+\$ 53	Specify fabric color number.	
• Price group 7	+\$ 64	Specify fabric color number.	
• Price group 8	+\$ 79	Specify fabric color number.	
• Price group 9	+\$ 97	Specify fabric color number.	
• Price group 10	+\$112	Specify fabric color number.	
• Steelcase Leather	+\$ 94	Specify leather color number.	
• Select Surfaces leather price group 1	+\$ 94	▶ See <i>Surface Materials Reference Manual</i> .	
• Elmosoft Leather	+\$110	Specify Elmosoft leather color number.	
• Select Surfaces leather price group 2	+\$110	▶ See <i>Surface Materials Reference Manual</i> .	
• Customer's Own Material	+\$ 38	▶ See <i>Surface Materials Reference Manual</i> .	
• Customer's Own Leather	+\$ 38	▶ See <i>Surface Materials Reference Manual</i> .	
Cushion	• Cushion	+\$125	Specify with <i>cushion top</i> .
Cup Holder	• On 480120	+\$ 35	Specify with <i>cup holder</i> .
Tablet Stand	• On 480120	+\$ 35	Specify with <i>tablet stand</i> .
Casters	• Soft casters	+\$ 31	Specify with <i>soft casters</i> .
Glides	• Glides: sterling dark solid	+\$ 25	Specify with <i>glides</i> .

Tip: Fire Code Seating (FCS) option is available with certain plastic color choices only.
▶ Page 462

Tip: Cup holder is available on Node models with personal worksurface only.

Tip: ShareSurface is not available with cup holder or tablet stand option.

▶ Detailed dimensions, page 232

Specification Information

Style Number	Base Price
--------------	------------

Without Personal Worksurface

480110	\$459
--------	-------



With Personal Worksurface

480120	\$687
--------	-------

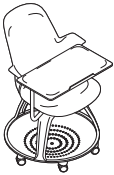

With ShareSurface

480170	\$728
--------	-------

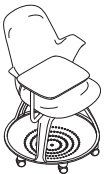

Node 480 Series Collaborative Chairs

With Five-Arm Base

SIN 711.18



Tip: Fire Code Seating (FCS) option is available with certain plastic color choices only.

▶ Page 462

Tip: Metal components will match plastic color for base.

Tip: Cup holder is available on Node models with personal worksurface only.

Tip: ShareSurface is not available with cup holder or tablet stand option.

Standard Includes	Required to Specify
<ul style="list-style-type: none"> ▶ Need help? Product details, page 228 • Seat shell: plastic • Five-arm base: plastic • Metal components: 0835 Black paint • Swivel seat • 5¼" pneumatic seat-height adjustment • Hard casters 	<ol style="list-style-type: none"> 1 Style number 2 Plastic color number for seat shell 3 Plastic color number for five-arm base 4 Options, if selected (see below) <p>▶ See <i>Surface Materials</i>, page 432.</p>

Options	Price	Required to Specify
Surface Materials <ul style="list-style-type: none"> • Plastic price group 1 • Plastic price group 2 • Fire Code Seating (FCS) 	<ul style="list-style-type: none"> No cost +\$ 28 +\$ 80 	<ul style="list-style-type: none"> Specify color number. ▶ See <i>Surface Materials</i>, page 432. Specify color number. ▶ See <i>Surface Materials</i>, page 432. Add suffix F to style number.
Cushion <ul style="list-style-type: none"> • Price group 1 • Price group 2 • Price group 3 • Price group 4 • Price group 5 • Price group 6 • Price group 7 • Price group 8 • Price group 9 • Price group 10 • Steelcase Leather • Select Surfaces leather price group 1 • Elmosoft Leather • Select Surfaces leather price group 2 • Customer's Own Material • Customer's Own Leather 	<ul style="list-style-type: none"> No cost +\$ 10 +\$ 27 +\$ 36 +\$ 43 +\$ 53 +\$ 64 +\$ 79 +\$ 97 +\$112 +\$ 94 +\$ 94 +\$110 +\$110 +\$ 38 +\$ 38 	<ul style="list-style-type: none"> Specify fabric color number. Specify fabric color number. Specify fabric color number. Specify fabric color number. Specify fabric color number. Specify fabric color number. Specify fabric color number. Specify fabric color number. Specify fabric color number. Specify fabric color number. Specify leather color number. ▶ See <i>Surface Materials Reference Manual</i>. Specify Elmosoft leather color number. ▶ See <i>Surface Materials Reference Manual</i>. ▶ See <i>Surface Materials Reference Manual</i>. ▶ See <i>Surface Materials Reference Manual</i>.
Base <ul style="list-style-type: none"> • Platinum on 480130 and 480180 • Element on 480130 and 480180 • Platinum on 480150 • Element on 480150 	<ul style="list-style-type: none"> +\$ 34 +\$ 34 +\$ 38 +\$ 38 	<ul style="list-style-type: none"> Specify with 6249 Platinum. Specify with 6337 Element. Specify with 6249 Platinum. Specify with 6337 Element.
Cushion <ul style="list-style-type: none"> • Cushion 	<ul style="list-style-type: none"> +\$125 	<ul style="list-style-type: none"> Specify with cushion top.
Cup Holder <ul style="list-style-type: none"> • On 480150 	<ul style="list-style-type: none"> +\$ 35 	<ul style="list-style-type: none"> Specify with cup holder.
Tablet Stand <ul style="list-style-type: none"> • On 480150 	<ul style="list-style-type: none"> +\$ 35 	<ul style="list-style-type: none"> Specify with tablet stand.
Casters <ul style="list-style-type: none"> • Soft, dark grey treaded, dual-wheel roll-control casters for use on hard floors 	<ul style="list-style-type: none"> +\$ 25 	<ul style="list-style-type: none"> Specify with soft roll-control casters.
Glides <ul style="list-style-type: none"> • Glides: black plastic 	<ul style="list-style-type: none"> +\$ 25 	<ul style="list-style-type: none"> Specify with glides.

▶ Detailed dimensions, page 232

Specification Information

• Style • Number	• Base • Price
---------------------	-------------------

Without Personal Worksurface

480130	\$414
--------	-------



With Personal Worksurface

480150	\$687
--------	-------



With ShareSurface

480180	\$728
--------	-------



Node 480 Series Mid-Back Collaborative Chairs

With Tripod Base

SIN 711.18



Standard Includes		Required to Specify
▶ Need help? Product details, page 228	<ul style="list-style-type: none"> • Seat shell: plastic • Tripod base: plastic • Storage tray: sterling dark solid • Metal components: 0835 Black paint • Swivel seat • Worksurface, if selected: plastic • Hard casters 	<ol style="list-style-type: none"> 1 Style number 2 Plastic color number for seat shell 3 Plastic color number for tripod base 4 Paint color number for metal components 5 Plastic color number for personal worksurface, if selected 6 Options, if selected (see below) <p>▶ See <i>Surface Materials</i>, page 432.</p>

Options	Price	Required to Specify	
Surface Materials			
Platinum or Champagne Metallic metal components			
• On 480210 and 480270	+\$ 10	Specify with 4799 Platinum or 4750 Champagne Metallic.	
• On 480220	+\$ 24	Specify with 4799 Platinum or 4750 Champagne Metallic.	
Seat shell			
• Plastic price group 1	No cost	Specify color number. ▶ See <i>Surface Materials</i> , page 432.	
• Plastic price group 2	+\$ 28	Specify color number. ▶ See <i>Surface Materials</i> , page 432.	
• Fire Code Seating (FCS)	+\$ 80	Add suffix F to style number.	
Cushion			
• Price group 1	No cost	Specify fabric color number.	
• Price group 2	+\$ 10	Specify fabric color number.	
• Price group 3	+\$ 27	Specify fabric color number.	
• Price group 4	+\$ 36	Specify fabric color number.	
• Price group 5	+\$ 43	Specify fabric color number.	
• Price group 6	+\$ 53	Specify fabric color number.	
• Price group 7	+\$ 64	Specify fabric color number.	
• Price group 8	+\$ 79	Specify fabric color number.	
• Price group 9	+\$ 97	Specify fabric color number.	
• Price group 10	+\$112	Specify fabric color number.	
• Steelcase Leather	+\$ 94	Specify leather color number.	
• Select Surfaces leather price group 1	+\$ 94	▶ See <i>Surface Materials Reference Manual</i> .	
• Elmosoft Leather	+\$110	Specify Elmosoft leather color number.	
• Select Surfaces leather price group 2	+\$110	▶ See <i>Surface Materials Reference Manual</i> .	
• Customer's Own Material	+\$ 38	▶ See <i>Surface Materials Reference Manual</i> .	
• Customer's Own Leather	+\$ 38	▶ See <i>Surface Materials Reference Manual</i> .	
Cushion	• Cushion	+\$125	Specify with cushion top.
Cup Holder	• On 480220	+\$ 35	Specify with cup holder.
Tablet Stand	• On 480220	+\$ 35	Specify with tablet stand.
Casters	• Soft, dark grey treaded, dual-wheel roll-control casters for use on hard floors	+\$ 31	Specify with soft roll-control casters.
Glides	• Glides: sterling dark solid	+\$ 25	Specify with glides.

Tip: Fire Code Seating (FCS) option is available with certain plastic color choices only.
▶ Page 462

Tip: Cup holder is available on Node models with personal worksurface only.

Tip: ShareSurface is not available with cup holder or tablet stand option.

▶ Detailed dimensions, page 232

Specification Information

• **Style**
• **Number**

• **Base**
• **Price**

Without Personal Worksurface

480210 \$459



With Personal Worksurface

480220 \$687



With ShareSurface

480270 \$728



Node 480 Series Mid-Back Collaborative Chairs

With Five-Arm Base

SIN 711.18



Tip: Fire Code Seating (FCS) option is available with certain plastic color choices only.

▶ Page 462

Tip: Metal components will match plastic color for base.

Tip: Cup holder is available on Node models with personal worksurface only.

Tip: ShareSurface is not available with cup holder or tablet stand option.

Standard Includes		Required to Specify
▶ Need help? Product details, page 228	<ul style="list-style-type: none"> • Seat shell: plastic • Five-arm base: plastic • Metal components: 0835 Black paint • Swivel seat • 5¼" pneumatic seat-height adjustment • Hard casters 	<ol style="list-style-type: none"> 1 Style number 2 Plastic color number for seat shell 3 Plastic color number for five-arm base 4 Options, if selected (see below) <p>▶ See <i>Surface Materials</i>, page 432.</p>

Options	Price	Required to Specify	
Surface Materials			
Seat shell			
• Plastic price group 1	No cost	Specify color number.	
• Plastic price group 2	+\$ 28	▶ See <i>Surface Materials</i> , page 432.	
• Fire Code Seating (FCS)	+\$ 80	Specify color number.	
		▶ See <i>Surface Materials</i> , page 432.	
		Add suffix F to style number.	
Cushion			
• Price group 1	No cost	Specify fabric color number.	
• Price group 2	+\$ 10	Specify fabric color number.	
• Price group 3	+\$ 27	Specify fabric color number.	
• Price group 4	+\$ 36	Specify fabric color number.	
• Price group 5	+\$ 43	Specify fabric color number.	
• Price group 6	+\$ 53	Specify fabric color number.	
• Price group 7	+\$ 64	Specify fabric color number.	
• Price group 8	+\$ 79	Specify fabric color number.	
• Price group 9	+\$ 97	Specify fabric color number.	
• Price group 10	+\$112	Specify fabric color number.	
• Steelcase Leather	+\$ 94	Specify leather color number.	
• Select Surfaces leather price group 1	+\$ 94	▶ See <i>Surface Materials Reference Manual</i> .	
• Elmosoft Leather	+\$110	Specify Elmosoft leather color number.	
• Select Surfaces leather price group 2	+\$110	▶ See <i>Surface Materials Reference Manual</i> .	
• Customer's Own Material	+\$ 38	▶ See <i>Surface Materials Reference Manual</i> .	
• Customer's Own Leather	+\$ 38	▶ See <i>Surface Materials Reference Manual</i> .	
Base			
• Platinum on 480230 and 480280	+\$ 34	Specify with 6249 Platinum.	
• Element on 480230 and 480280	+\$ 34	Specify with 6337 Element.	
• Platinum on 480250	+\$ 38	Specify with 6249 Platinum.	
• Element on 480250	+\$ 38	Specify with 6337 Element.	
Cushion	• Cushion	+\$125	Specify with cushion top.
Cup Holder	• On 480250	+\$ 35	Specify with cup holder.
Tablet Stand	• On 480250	+\$ 35	Specify with tablet stand.
Casters	• Soft, dark grey treaded, dual-wheel roll-control casters for use on hard floors	+\$ 25	Specify with soft roll-control casters.
Glides	• Glides: black plastic	+\$ 25	Specify with glides.

▶ Detailed dimensions, page 232

Specification Information

• Style Number	• Base Price
----------------	--------------

Without Personal Worksurface

480230	\$414
---------------	-------



With Personal Worksurface

480250	\$687
---------------	-------



With ShareSurface

480280	\$728
---------------	-------



Node 480 Series Collaborative Stool

With Five-Arm Base

SIN 711.18

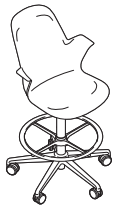

Tip: Fire Code Seating (FCS) option is available with certain plastic color choices only.
▶ Page 462

Tip: Metal components will match plastic color for base.

Standard Includes	Required to Specify
<ul style="list-style-type: none"> ▶ Need help? Product details, page 228 • Seat shell: plastic • Five-arm base: plastic • Metal components: 0835 Black paint • Swivel seat • 8½" pneumatic seat-height adjustment • Hard casters 	<ol style="list-style-type: none"> 1 Style number 2 Plastic color number for seat shell 3 Plastic color number for five-arm base 4 Options, if selected (see below) <ul style="list-style-type: none"> ▶ See <i>Surface Materials</i>, page 432.

Options	Price	Required to Specify
Surface Materials <ul style="list-style-type: none"> • Plastic price group 1 • Plastic price group 2 • Fire Code Seating (FCS) 	<ul style="list-style-type: none"> No cost +\$ 28 +\$ 80 	<ul style="list-style-type: none"> Specify color number. ▶ See <i>Surface Materials</i>, page 432. Specify color number. ▶ See <i>Surface Materials</i>, page 432. Add suffix F to style number.
Cushion <ul style="list-style-type: none"> • Price group 1 • Price group 2 • Price group 3 • Price group 4 • Price group 5 • Price group 6 • Price group 7 • Price group 8 • Price group 9 • Price group 10 • Steelcase Leather • Select Surfaces leather price group 1 • Elmosoft Leather • Select Surfaces leather price group 2 • Customer's Own Material • Customer's Own Leather 	<ul style="list-style-type: none"> No cost +\$ 10 +\$ 27 +\$ 36 +\$ 43 +\$ 53 +\$ 64 +\$ 79 +\$ 97 +\$112 +\$ 94 +\$ 94 +\$110 +\$110 +\$ 38 +\$ 38 	<ul style="list-style-type: none"> Specify fabric color number. Specify fabric color number. Specify fabric color number. Specify fabric color number. Specify fabric color number. Specify fabric color number. Specify fabric color number. Specify fabric color number. Specify fabric color number. Specify fabric color number. Specify leather color number. ▶ See <i>Surface Materials Reference Manual</i>. Specify Elmosoft leather color number. ▶ See <i>Surface Materials Reference Manual</i>. ▶ See <i>Surface Materials Reference Manual</i>. ▶ See <i>Surface Materials Reference Manual</i>.
Seat-Height <ul style="list-style-type: none"> • 7½" pneumatic seat-height adjustment 	<ul style="list-style-type: none"> No cost 	<ul style="list-style-type: none"> Specify with 7" pneumatic seat-height adjustment.
Base <ul style="list-style-type: none"> • Platinum • Element 	<ul style="list-style-type: none"> +\$ 99 +\$ 99 	<ul style="list-style-type: none"> Specify with 6249 Platinum. Specify with 6337 Element.
Cushion <ul style="list-style-type: none"> • Cushion 	<ul style="list-style-type: none"> +\$125 	<ul style="list-style-type: none"> Specify with cushion top.
Casters <ul style="list-style-type: none"> • Soft, dark grey treaded, dual-wheel roll-control casters for use on hard floors 	<ul style="list-style-type: none"> +\$ 25 	<ul style="list-style-type: none"> Specify with soft roll-control casters.

Specification Information	
Style Number	Base Price
480140	\$610

▶ Detailed dimensions, page 232

Node 480 Series Mid-Back Collaborative Stool

Node 480 Series Mid-Back Collaborative Stool

With Five-Arm Base

SIN 711.18

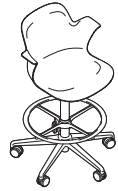

Node 480 Series

Standard Includes		Required to Specify
<ul style="list-style-type: none"> ▶ Need help? Product details, page 228 	<ul style="list-style-type: none"> • Seat shell: plastic • Five-arm base: plastic • Metal components: 0835 Black paint • Swivel seat • 8½" pneumatic seat-height adjustment • Hard casters 	<ol style="list-style-type: none"> 1 Style number 2 Plastic color number for seat shell 3 Plastic color number for five-arm base 4 Options, if selected (see below) <ul style="list-style-type: none"> ▶ See <i>Surface Materials</i>, page 432.

Tip: Fire Code Seating (FCS) option is available with certain plastic color choices only.
▶ Page 462

Tip: Metal components will match plastic color for base.

Options	Price	Required to Specify	
Surface Materials			
<ul style="list-style-type: none"> • Seat shell • Plastic price group 1 • Plastic price group 2 • Fire Code Seating (FCS) 	<ul style="list-style-type: none"> No cost +\$ 28 +\$ 80 	<ul style="list-style-type: none"> Specify color number. ▶ See <i>Surface Materials</i>, page 432. Specify color number. ▶ See <i>Surface Materials</i>, page 432. Add suffix F to style number. 	
<ul style="list-style-type: none"> • Cushion • Price group 1 • Price group 2 • Price group 3 • Price group 4 • Price group 5 • Price group 6 • Price group 7 • Price group 8 • Price group 9 • Price group 10 • Steelcase Leather • Select Surfaces leather price group 1 • Elmosoft Leather • Select Surfaces leather price group 2 • Customer's Own Material • Customer's Own Leather 	<ul style="list-style-type: none"> No cost +\$ 10 +\$ 27 +\$ 36 +\$ 43 +\$ 53 +\$ 64 +\$ 79 +\$ 97 +\$112 +\$ 94 +\$ 94 +\$110 +\$110 +\$ 38 +\$ 38 	<ul style="list-style-type: none"> Specify fabric color number. Specify fabric color number. Specify fabric color number. Specify fabric color number. Specify fabric color number. Specify fabric color number. Specify fabric color number. Specify fabric color number. Specify fabric color number. Specify fabric color number. Specify fabric color number. Specify leather color number. ▶ See <i>Surface Materials Reference Manual</i>. Specify Elmosoft leather color number. ▶ See <i>Surface Materials Reference Manual</i>. ▶ See <i>Surface Materials Reference Manual</i>. ▶ See <i>Surface Materials Reference Manual</i>. 	
Seat-Height	<ul style="list-style-type: none"> • 7½" pneumatic seat-height adjustment 	<ul style="list-style-type: none"> No cost 	<ul style="list-style-type: none"> Specify with 7" pneumatic seat-height adjustment.
Base	<ul style="list-style-type: none"> • Platinum • Element 	<ul style="list-style-type: none"> +\$ 99 +\$ 99 	<ul style="list-style-type: none"> Specify with 6249 Platinum. Specify with 6337 Element.
Cushion	<ul style="list-style-type: none"> • Cushion 	<ul style="list-style-type: none"> +\$125 	<ul style="list-style-type: none"> Specify with cushion top.
Casters	<ul style="list-style-type: none"> • Soft, dark grey treaded, dual-wheel roll-control casters for use on hard floors 	<ul style="list-style-type: none"> +\$ 25 	<ul style="list-style-type: none"> Specify with soft roll-control casters.

Specification Information	
Style Number	Base Price
480240	\$610

▶ Detailed dimensions, page 232

Brody 488 Series

Brody is a destination for focus. Every detail has been designed with focus in mind, creating a place where people can escape while still having access to the tools, information, and people they need to be most productive.

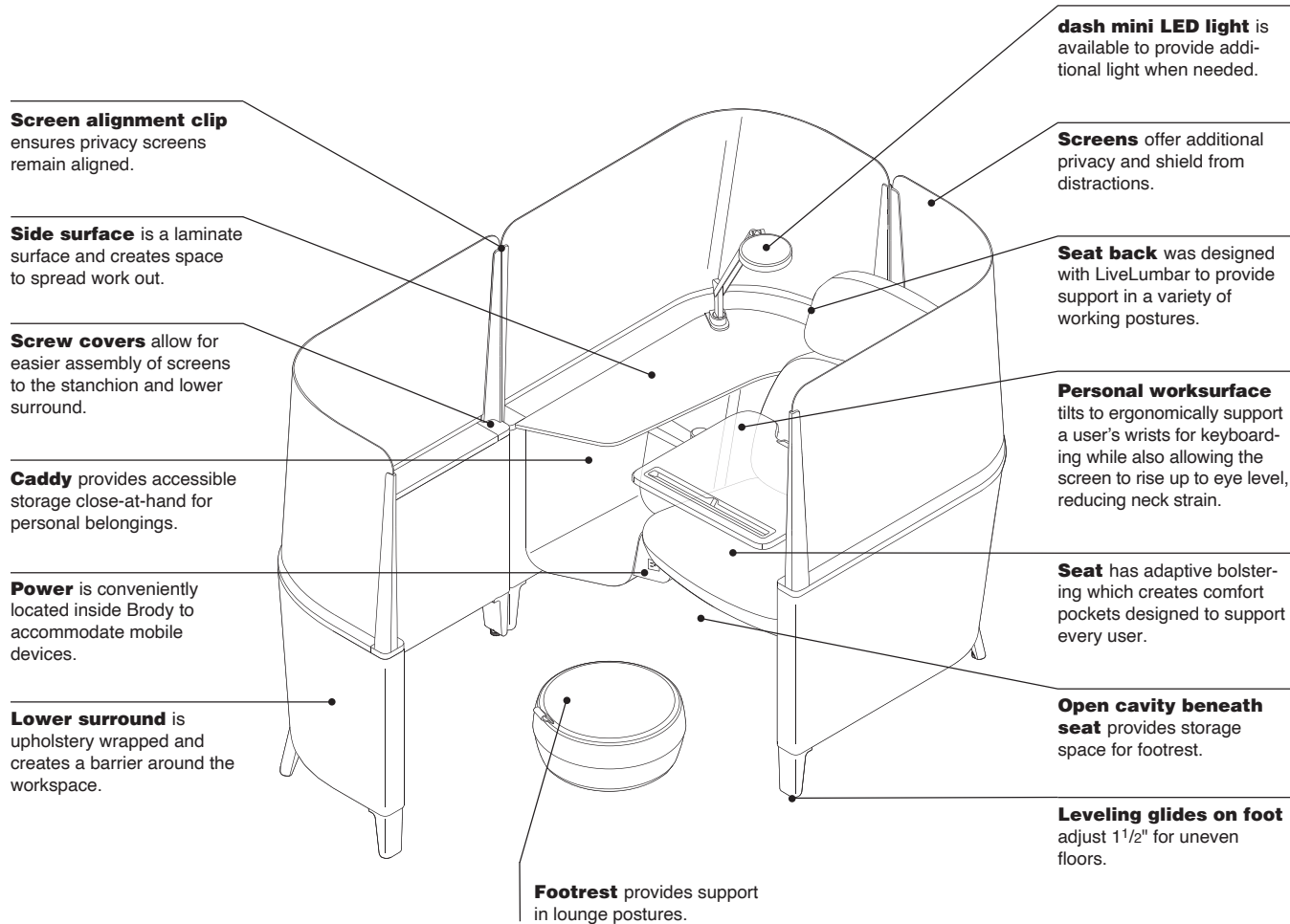

Product Details

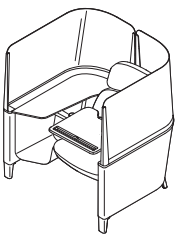
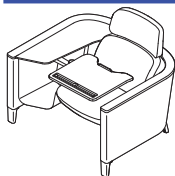

Brody is available with and without screens.

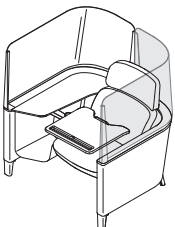

Screens on privacy lounge with extension can only be omitted on the opposite side of where the side surface is located.

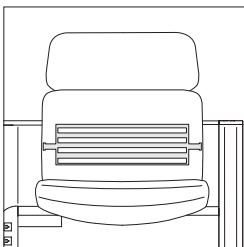

LiveLumbar offers a dialed in spring force in the lumbar region that actively supports the lower back.

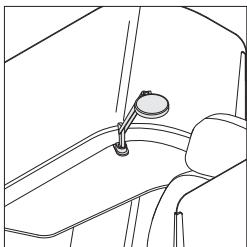

dash mini LED light is available if power has been specified and can be field installed.

dash mini LED light adjusts 19⁷/₈"H from the side surface. The base and head pivot 360°.

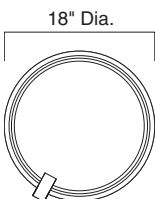
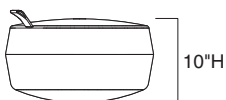

Footrest has plastic base and an overall height of 10"H and a diameter of 18".

Integrated loop on footrest allows for easy repositioning of the footrest in the workspace. It is 13¹/₄"W x 2" long and can be used to tether the footrest to the frame.

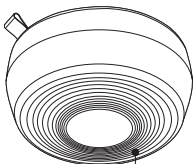

Non-slip surface

Footrest base is domed in the middle, allowing it to move to adapt to user preferences.

Bottom of footrest has a non-slip surface toward the outside to prevent sliding.

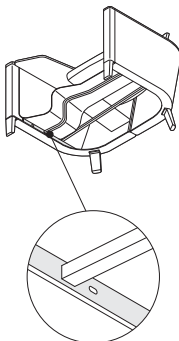

Footrest can be tethered to the frame. There is a small slot on the frame designed for a Kensington lock.

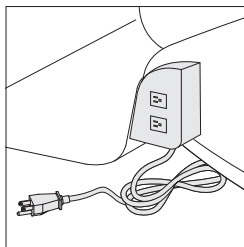

Two NEMA outlets

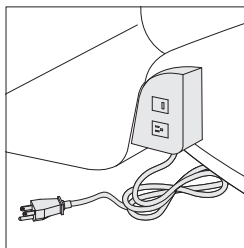

One NEMA, one USB outlet

Power is standard with two three-prong NEMA outlets. It is available with one three-prong NEMA outlet and one USB 2.0 (2.1 amp) outlet as an option. The cord is 10' long and is available with either a standard three-prong NEMA plug for use with standard receptacles or with Steelcase's proprietary Thread low-profile plug for use with one-door and two-door low-profile connectors.

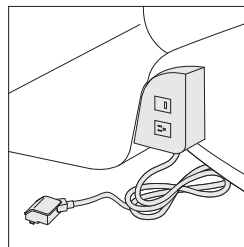

Proprietary low-profile plug can only be used with the Thread system and will not interface with existing receptacles. In order to achieve ADA compliance for connectors in an egress location, we developed our own plug design.

Note: Always consult your local inspector prior to purchasing the Thread system to ensure all local codes and ordinances are satisfied since local regulations may supersede those spelled out in the National Electric Code.

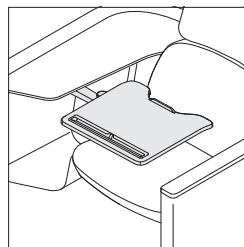

Personal worksurface has a cut out to hold technology like smart phones and tablets. The worksurface measures 16⁵/₈"D x 18¹/₄"W and is 26⁷/₈"H from the floor.

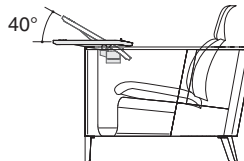

Personal worksurface tilts up to 40° allowing users to bring work to eye level.

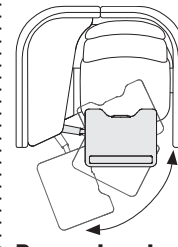

Personal worksurface swivels 125 degrees in and out to allow easy entry and exit.

Brody 488 Series, continued

Surface Materials

▶ See surface materials on page 432 for specific availability or refer to the *Surface Materials Reference Manual* for further information.

Seat upholstery

- Fabric
- Vinyl
- Leather
- Elmosoft Leather
- Select Surfaces leather
- COL
- COM

Screen

- Acrylic – 6559 Satin Ice
- Buzz2 fabric
- COM

Tip: COM selections are strictly limited. Please reference the COM page at www.steelcase.com to make your selections.

Lower surround upholstery

- Fabric
- COM

Tip: The standard application direction of fabric on the lower surround is warp horizontal. Standard Steelcase fabrics were designed for this application direction.

Upper footrest

- Fabric
- Vinyl
- Leather
- Elmosoft Leather
- Select Surfaces leather
- Plastic
- COL
- COM

Tip: Consider fabrics appropriate for high-wear environments for the upper footrest.

Lower footrest

- 6053 Seagull
- 6059 Sterling Dark

Trim

- Fabric
- Plastic
- COM

Light

- 4231 Arctic White
- 4710 Low Gloss Black
- 4799 Platinum
- Accent paint (option)

Side surface

- 2410 Graphite Walnut
- 2511 Winter on Maple
- 2535 Virginia Walnut
- 2536 Blackwood
- 2883 Seagull
- 2HAT Acacia

Storage caddy, lower surround trim, seat shell, personal worksurface, personal worksurface arm, screen brackets, power, frame, foot, and back of caddy finishes can be found on the color scheme matrix.

▶ See page 247.

Programs & Services

▶ See the *Surface Materials Reference Manual* for further detail about programs and services offered for seating.

The Customer's Own Material (COM) Program

offers the opportunity for customers to select fabrics that are not offered through the standard Steelcase surface materials program for use on Steelcase products. Through the COM program, Steelcase will test your materials for application on Steelcase products. Once approved, you can place your order. Steelcase will facilitate the entire ordering process and give you a production schedule. Steelcase will order the COM fabric directly from the textile manufacturer. For up-to-date information regarding fabric test results for all COM fabrics and details regarding yardage requirements for most Seating lines, visit the COM website. To locate the COM website:

- Visit www.steelcase.com

Soil retardants are treatments that provide long-term soil and stain resistance to a fabric without affecting the shade or the integrity of the fabric. The following Steelcase Textiles are available pre-treated with soil retardant. (You do not need to select the soil-retardant option for these fabrics and incur the upcharge.)

- Jacks
- Link
- Spyder

For information on soil retardant fabrics on Select Surfaces, please refer to the *Surface Materials Reference Manual*.

Soil-retardant treatment is available on all other seating fabrics at an additional upcharge per seating unit. To order this option, please select "Soil-Retardant Treatment" under "Optional Accessories."

For soil-retardant treatment on COMs, please select "Soil-Retardant Treatment" under "Optional Accessories." Minimums or additional yardage may be required. Please contact the vendor directly for specific information.

Extended lead times may be necessary for this service.

Contact your Steelcase Solutions Fulfillment Team Representative at 1.888.STEELCASE (1.888.783.3522) or send an email to lineone@steelcase.com.

Dimensions

▶ Page 250

Resources**Printed Materials**

▶ Brody WorkLounge Brochure (15-0000167)

Color Scheme Matrix

Color Scheme	Foot	Screen Brackets	Frame	Lower Surround Trim	Seat Shell	Screen Clip — Acrylic Screen
Light	Seagull 7243	Seagull 7243	Merle 7360	Seagull 6053	Platinum Solid 6249	Seagull 7243
Medium	Platinum Metallic 4799	Platinum Metallic 4799	Merle 7360	Platinum Solid 6249	Sterling Dark Solid 6059	Platinum Metallic 4799
Dark	Sterling Dark 7250	Sterling Dark 7250	Merle 7360	Sterling Dark Solid 6059	Sterling Dark Solid 6059	Sterling Dark 7250
Matte Copper	Matte Copper 4B25	Matte Copper 4B25	Merle 7360	Sterling Dark Solid 6059	Sterling Dark Solid 6059	Sterling Dark 7250
Matte Brass	Matte Brass 4B22	Matte Brass 4B22	Merle 7360	Sterling Dark Solid 6059	Sterling Dark Solid 6059	Sterling Dark 7250
Burnished Bronze	Burnished Bronze 4B23	Burnished Bronze 4B23	Merle 7360	Sterling Dark Solid 6059	Sterling Dark Solid 6059	Sterling Dark 7250
Night Bronze	Night Bronze 4B24	Night Bronze 4B24	Merle 7360	Sterling Dark Solid 6059	Sterling Dark Solid 6059	Sterling Dark 7250
Obsidian	Obsidian 4B20	Obsidian 4B20	Merle 7360	Sterling Dark Solid 6059	Sterling Dark Solid 6059	Sterling Dark 7250

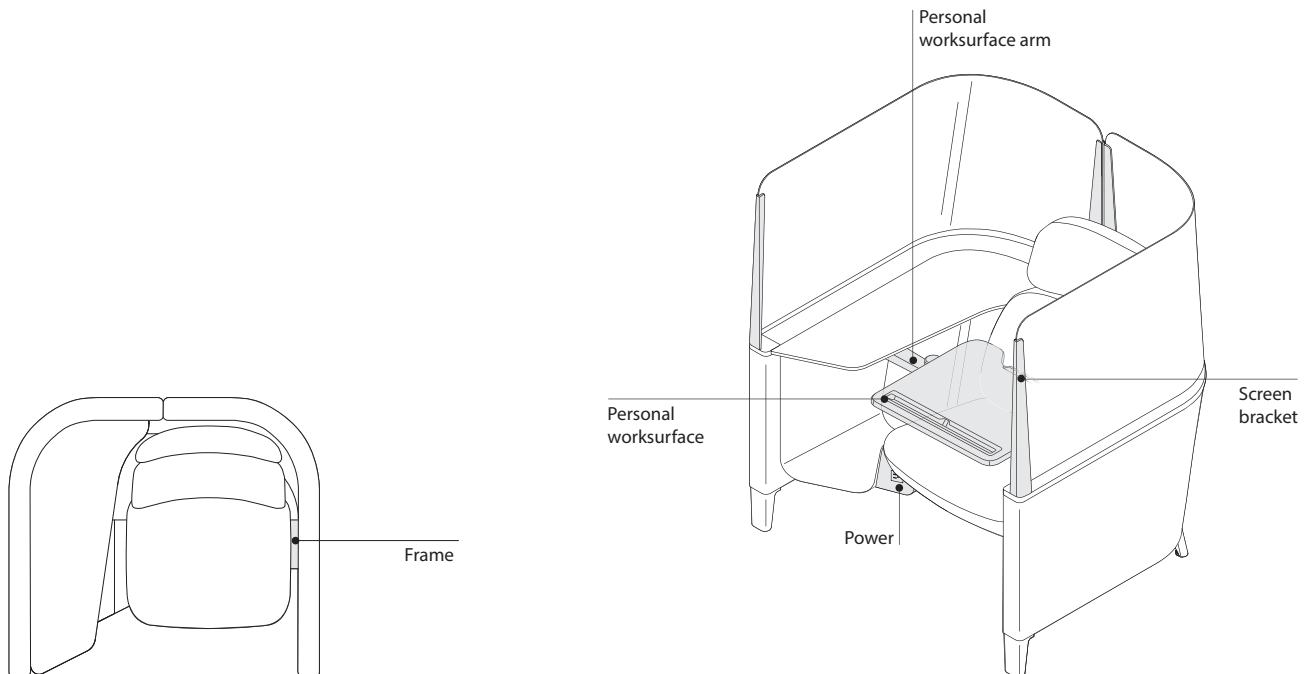

Brody 488 Series, continued

Color Scheme Matrix

Color Scheme	Personal Worksurface	Personal Worksurface Arm	Caddy	Back of Caddy	Power
Light	Seagull 6053	Platinum Metallic 4799	Seagull 6053	Merle 6527	Merle 6527
Medium	Platinum Solid 6249	Platinum Metallic 4799	Merle 6527	Merle 6527	Merle 6527
Dark	Sterling Dark Solid 6059	Sterling Dark 7250	Sterling Dark Solid 6059	Merle 6527	Merle 6527
Matte Copper	Sterling Dark Solid 6059	Matte Copper 4B25	Sterling Dark Solid 6059	Merle 6527	Merle 6527
Matte Brass	Sterling Dark Solid 6059	Matte Brass 4B22	Sterling Dark Solid 6059	Merle 6527	Merle 6527
Burnished Bronze	Sterling Dark Solid 6059	Burnished Bronze 4B23	Sterling Dark Solid 6059	Merle 6527	Merle 6527
Night Bronze	Sterling Dark Solid 6059	Night Bronze 4B24	Sterling Dark Solid 6059	Merle 6527	Merle 6527
Obsidian	Sterling Dark Solid 6059	Obsidian 4B20	Sterling Dark Solid 6059	Merle 6527	Merle 6527

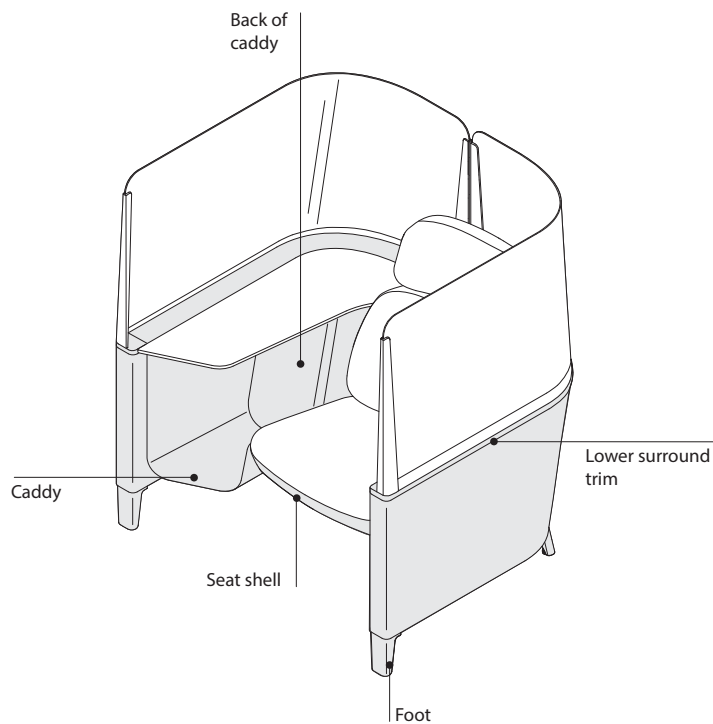

Dimensions

Brody 488 Series

Features	Overall Depth	Width	Height	Seat Depth	Functional Seat Depth	Seat Width	Seat Height from Floor	Back Width	Lumbar Height from Floor	Lower Surround Height from Floor
Brody WorkLounge 488 Series										
WorkLounge	36 ¹ / ₁₀ "	42 ¹³ / ₁₆ "	36"	21 ⁵ / ₈ "	19 ⁷ / ₈ "	22 ⁵ / ₈ "	16 ⁷ / ₈ "	21 ⁷ / ₈ "	18 ³ / ₈ "	25"
Privacy Lounge	36 ¹ / ₁₀ "	42 ¹³ / ₁₆ "	48 ¹ / ₂ "	21 ⁵ / ₈ "	19 ⁷ / ₈ "	22 ⁵ / ₈ "	16 ⁷ / ₈ "	21 ⁷ / ₈ "	18 ³ / ₈ "	25"
Privacy Lounge with Extension	72 ¹ / ₄ "	42 ¹³ / ₁₆ "	48 ¹ / ₂ "	21 ⁵ / ₈ "	19 ⁷ / ₈ "	22 ⁵ / ₈ "	16 ⁷ / ₈ "	21 ⁷ / ₈ "	18 ³ / ₈ "	25"

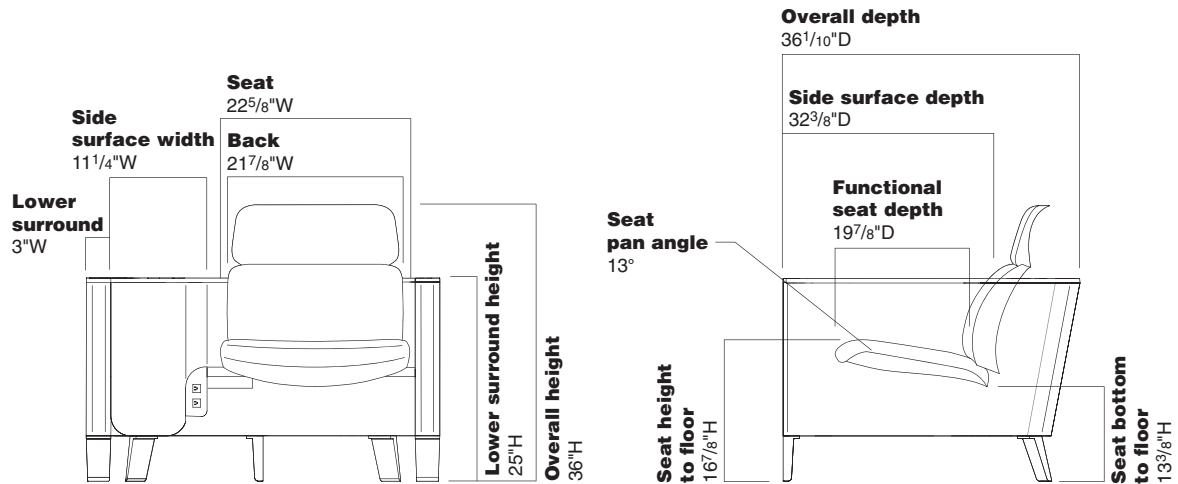

Lower Surround Trim Width	Screen Height	Side Surface Depth	Side Surface Width	Side Surface Height from Floor	Angle Between Seat and Back	Seat Pan Angle	Caddy
3"	N.A.	32 ³ / ₈ "	11 ¹ / ₄ "	25"	99°	13°	14 ¹ / ₄ "D x 10"W x 17 ³ / ₈ "H
3"	23 ¹ / ₂ "	32 ³ / ₈ "	11 ¹ / ₄ "	25"	99°	13°	14 ¹ / ₄ "D x 10"W x 17 ³ / ₈ "H
3"	23 ¹ / ₂ "	32 ³ / ₈ "	11 ¹ / ₄ "	25"	99°	13°	14 ¹ / ₄ "D x 10"W x 17 ³ / ₈ "H

Brody 488 Series

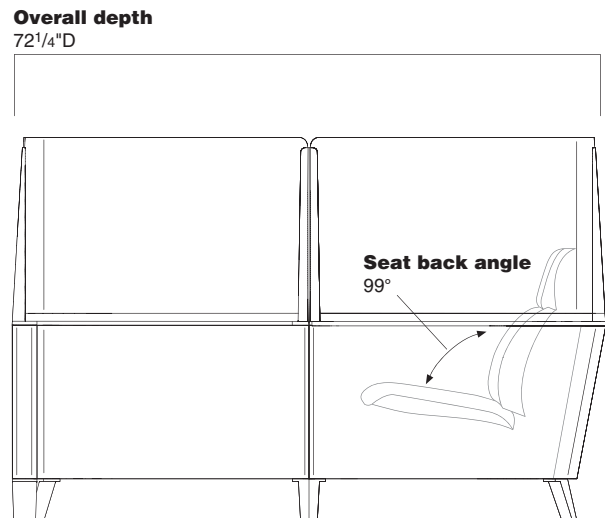
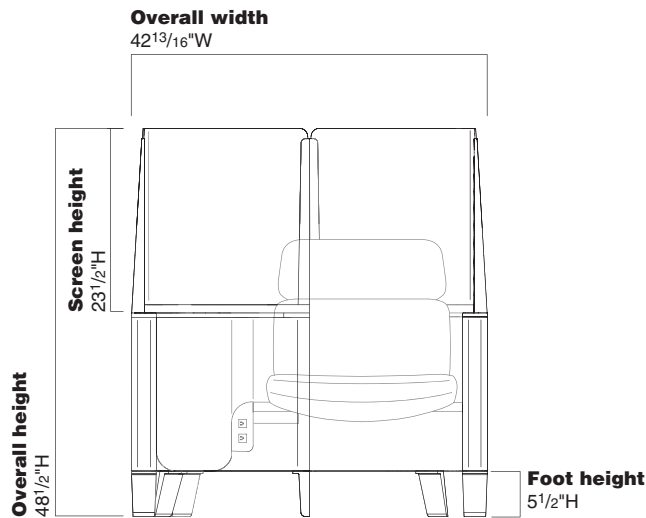

Brody Application Tips

Application Topics

Consider Brody embedded in five zones:

- Private individual focus area
- At thresholds to the neighborhood
- Along transition paths
- As supplement to the primary workstation
- Working lounge areas

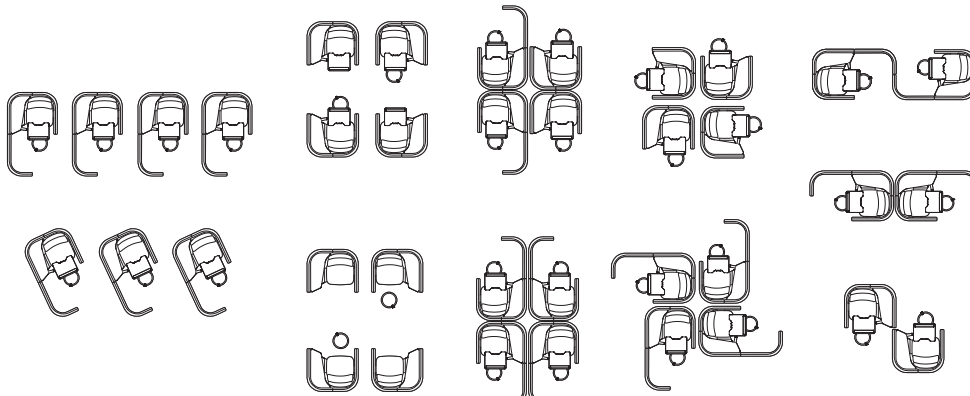

Parallel:
Side-by-Side/Angled

Booth

Clover

Pin Wheel

Yin Yang

Tip: Individual Brody units do not connect with brackets.

Brody Desk 488 Series

Brody is a destination for focus. Every detail has been designed with focus in mind, creating a place where people can escape while still having access to the tools, information, and people they need to be most productive.

Worksurface is available in laminate or veneer and creates space to spread work out.

dash mini LED light is available to provide additional light when needed.

Power is conveniently integrated into the worksurface.

Screens offer additional privacy and shield from distractions.

Lower surround is upholstery wrapped and creates a barrier around the workspace.

Leveling glides on foot adjust 1 1/2" for uneven floors.

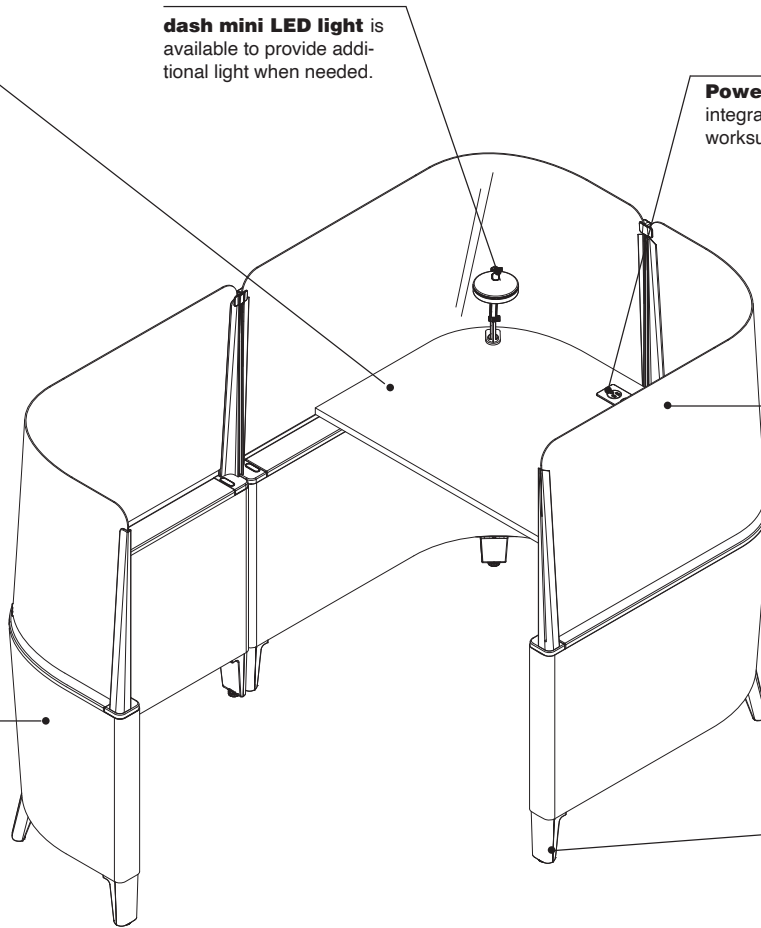

Product Details

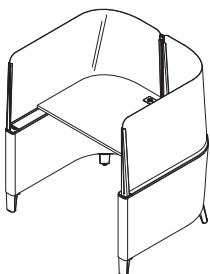

Brody desk always comes standard with screens.

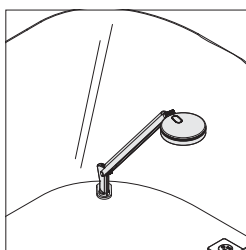

dash mini LED light is available if power has been specified and can be field installed.

dash mini LED light adjusts 19 $\frac{7}{8}$ "H from the worksurface. The base and head pivot 360°.

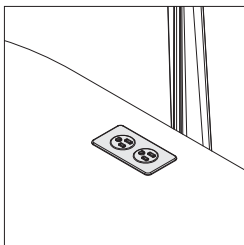

Two NEMA outlets

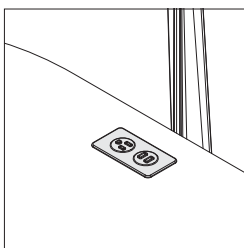

One NEMA, one USB outlet

Power is standard with two three-prong NEMA outlets. It is available with one three-prong NEMA outlet and one USB 2.0 (2.1 amp) outlet as an option. The cord is 10' long and is available with either a standard three-prong NEMA plug for use with standard receptacles or with Steelcase's proprietary Thread low-profile plug for use with one-door and two-door low-profile connectors.

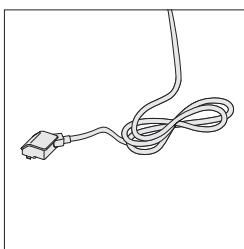

Proprietary low-profile plug can only be used with the Thread system and will not interface with existing receptacles. In order to achieve ADA compliance for connectors in an egress location, we developed our own plug design.

Note: Always consult your local inspector prior to purchasing the Thread system to ensure all local codes and ordinances are satisfied since local regulations may supersede those spelled out in the National Electric Code.

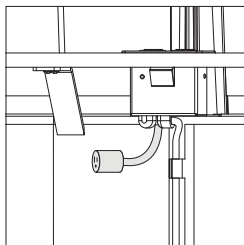

Power includes one convenience outlet standard below the worksurface to power the available dash mini LED light and retain a single power cord out.

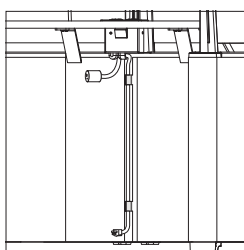

Wire management clips come standard with Brody desk to manage the power cord to the floor.

Surface Materials

► See surface materials on page 432 for specific availability or refer to the *Surface Materials Reference Manual* for further information.

Screen

- Arcylic – 6559 Satin Ice
- Buzz2 fabric
- COM

Tip: COM selections are strictly limited. Please reference the COM page at www.steelcase.com to make your selections.

Lower surround upholstery

- Fabric
- COM

Tip: The standard application direction of fabric on the lower surround is warp horizontal. Standard Steelcase fabrics were designed for this application direction.

Trim

- Fabric
- Plastic
- COM

Light

- 4231 Arctic White
- 4710 Low Gloss Black
- 4799 Platinum
- Accent paint (option)

Power

- 4799 Platinum Metallic
- 7243 Seagull
- 7250 Sterling Dark Solid

Worksurface

- Laminate
- Veneer

Lower surround trim, screen brackets, frame, and foot finishes can be found on the color scheme matrix.

► See page 256

Programs & Services

► See the *Surface Materials Reference Manual* for further detail about programs and services offered for seating.

The Customer's Own Material (COM) Program

offers the opportunity for customers to select fabrics that are not offered through the standard Steelcase surface materials program for use on Steelcase products. Through the COM program, Steelcase will test your materials for application on Steelcase products. Once approved, you can place your order. Steelcase will facilitate the entire ordering process and give you a production schedule. Steelcase will order the COM fabric directly from the textile manufacturer. For up-to-date information regarding fabric test results for all COM fabrics and details regarding yardage requirements for most Seating lines, visit the COM website. To locate the COM website:

- Visit www.steelcase.com

Dimensions

► Page 257

Brody Desk 488 Series, continued

Color Scheme Matrix

Color Scheme	Foot	Screen Brackets	Frame	Lower Surround Trim
Light	Seagull 7243	Seagull 7243	Merle 7360	Seagull 6053
Medium	Platinum Metallic 4799	Platinum Metallic 4799	Merle 7360	Platinum Solid 6249
Dark	Sterling Dark 7250	Sterling Dark 7250	Merle 7360	Sterling Dark Solid 6059
Matte Copper	Matte Copper 4B25	Matte Copper 4B25	Merle 7360	Sterling Dark Solid 6059
Matte Brass	Matte Brass 4B22	Matte Brass 4B22	Merle 7360	Sterling Dark Solid 6059
Burnished Bronze	Burnished Bronze 4B23	Burnished Bronze 4B23	Merle 7360	Sterling Dark Solid 6059
Night Bronze	Night Bronze 4B24	Night Bronze 4B24	Merle 7360	Sterling Dark Solid 6059
Obsidian	Obsidian 4B20	Obsidian 4B20	Merle 7360	Sterling Dark Solid 6059

Tip: If an upholstered screen is specified, then the screen clips will always be aluminum.

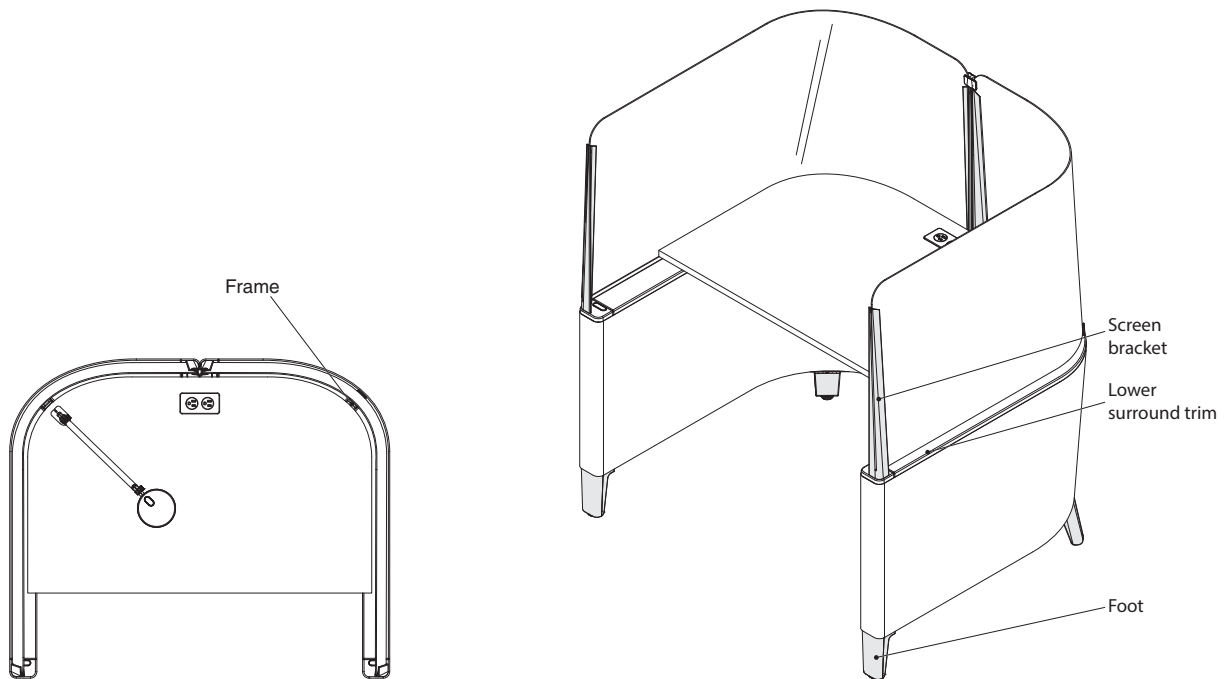

Dimensions

Brody Desk 488 Series

Features	Overall Depth	Width	Height	Lower Surround Trim Width	Screen Height	Worksurface Depth	Worksurface Width	Worksurface Height from Floor
Brody Desk 488 Series								
Privacy Desk	36 ¹ / ₈ "	43"	48 ¹ / ₂ "	3"	23 ¹ / ₂ "	24 ¹ / ₂ "	39"	28 ¹ / ₂ "
Privacy Desk with Extension	72 ¹ / ₄ "	43"	48 ¹ / ₂ "	3"	23 ¹ / ₂ "	24 ¹ / ₂ "	39"	28 ¹ / ₂ "

Brody 488 Series

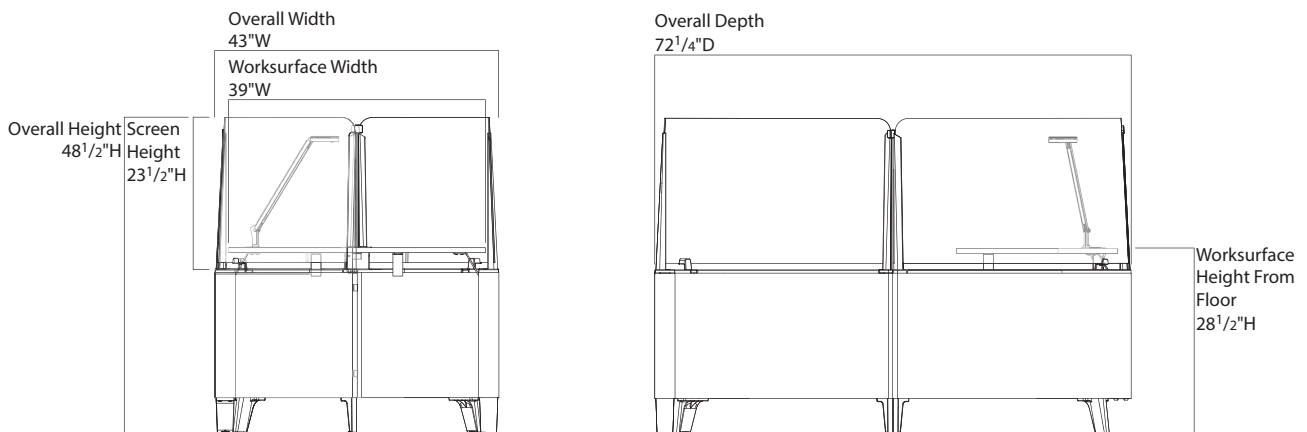
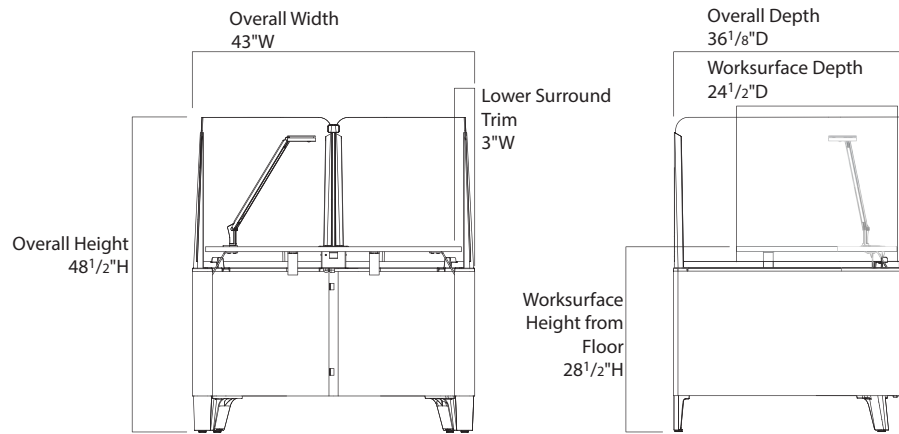

Brody Desk Application Tips

Application Topics

Consider Brody embedded in five zones:

- Private individual focus area
- At thresholds to the neighborhood
- Along transition paths
- As supplement to the primary workstation

Parallel: Side-by-Side



Serpentine

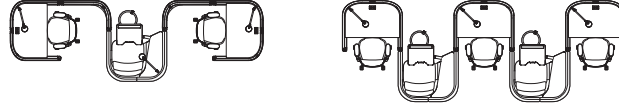

Parallel: Angled



Yin Yang



Tip: Individual Brody units do not connect with brackets.

Brody WorkLounge

SIN 711.16

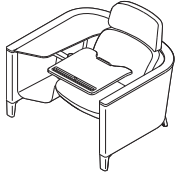

Tip: Illustration above shows right-hand worklounge.

Standard Includes	Required to Specify
<ul style="list-style-type: none"> ▶ Need help? Product details, page 244 • Lower surround: fabric price group 1 • Seat: fabric price group 1 • Side surface: laminate • Personal worksurface: plastic defaulted by color scheme • NEMA three prong power outlet: plastic defaulted by color scheme • Caddy: paint defaulted by color scheme 	<ol style="list-style-type: none"> 1 Style number 2 Color scheme (see below under Required Selections) 3 Left- or right-hand configuration (see below under Required Selections) 4 Fabric color number for upholstery on lower surround 5 Fabric color number for upholstery on seat 6 Laminate for side surface 7 Options, if selected (see below) <p>▶ See <i>Surface Materials</i>, page 432.</p>

Tip: For more information regarding color schemes, see page 247.

Tip: Handedness is determined by the side surface location. If specified as right-hand, the side surface and storage will be on the user's right (as seated).

Required Selections	Price	Required to Specify
Color Scheme WorkLounge <ul style="list-style-type: none"> • Light • Medium • Dark • Matte copper • Matte brass • Burnished bronze • Night bronze • Obsidian 	<ul style="list-style-type: none"> No cost No cost No cost +\$315 +\$315 +\$315 +\$315 +\$315 	<ul style="list-style-type: none"> Specify with <i>light color scheme</i>. Specify with <i>medium color scheme</i>. Specify with <i>dark color scheme</i>. Specify with <i>matte copper color scheme</i>. Specify with <i>matte brass color scheme</i>. Specify with <i>burnished bronze color scheme</i>. Specify with <i>night bronze color scheme</i>. Specify with <i>obsidian color scheme</i>.
Handedness <ul style="list-style-type: none"> • Left • Right 	<ul style="list-style-type: none"> No cost No cost 	<ul style="list-style-type: none"> Specify with <i>left-hand side surface and storage location</i>. Specify with <i>right-hand side surface and storage location</i>.

Tip: The trim is the top edge of the lower surround. If fabric trim is selected, the upholstery will match the upholstery specified on the lower surround.

Options	Price	Required to Specify
Surface Materials Upholstery on lower surround <ul style="list-style-type: none"> • Fabric price group 1 • Fabric price group 2 • Fabric price group 3 • Fabric price group 4 • Fabric price group 5 • Fabric price group 6 • Fabric price group 7 • Fabric price group 8 • Fabric price group 9 • Fabric price group 10 • Customer's Own Material (COM) 	<ul style="list-style-type: none"> No cost +\$ 47 +\$ 88 +\$124 +\$156 +\$194 +\$221 +\$280 +\$344 +\$391 No cost 	<ul style="list-style-type: none"> Specify fabric color number. Specify fabric color number. Specify fabric color number. Specify fabric color number. Specify fabric color number. Specify fabric color number. Specify fabric color number. Specify fabric color number. Specify fabric color number. Specify fabric color number. Specify fabric color number. <p>▶ See <i>Surface Materials Reference Manual</i>.</p>
Trim <ul style="list-style-type: none"> • Plastic • Fabric to match lower surround 	<ul style="list-style-type: none"> No cost +\$256 	<ul style="list-style-type: none"> Specify with <i>plastic trim</i>. Specify with <i>fabric trim</i>.
Upholstery on trim <ul style="list-style-type: none"> • Fabric price group 1 • Fabric price group 2 • Fabric price group 3 • Fabric price group 4 • Fabric price group 5 • Fabric price group 6 • Fabric price group 7 • Fabric price group 8 • Fabric price group 9 • Fabric price group 10 • Customer's Own Material (COM) 	<ul style="list-style-type: none"> No cost +\$ 17 +\$ 32 +\$ 45 +\$ 56 +\$ 71 +\$ 81 +\$101 +\$125 +\$142 No cost 	<ul style="list-style-type: none"> Specify fabric color number. Specify fabric color number. Specify fabric color number. Specify fabric color number. Specify fabric color number. Specify fabric color number. Specify fabric color number. Specify fabric color number. Specify fabric color number. Specify fabric color number.

▶ Options, continued on next page

▶ Detailed dimensions, page 250

► Options, continued from previous page

Options	Price	Required to Specify
Surface Materials, continued		
Upholstery on seat		
• Fabric price group 1	No cost	Specify fabric color number.
• Fabric price group 2	+\$ 26	Specify fabric color number.
• Fabric price group 3	+\$ 48	Specify fabric color number.
• Fabric price group 4	+\$ 68	Specify fabric color number.
• Fabric price group 5	+\$ 85	Specify fabric color number.
• Fabric price group 6	+\$106	Specify fabric color number.
• Fabric price group 7	+\$121	Specify fabric color number.
• Fabric price group 8	+\$153	Specify fabric color number.
• Fabric price group 9	+\$188	Specify fabric color number.
• Fabric price group 10	+\$213	Specify fabric color number.
• Steelcase leather upholstery	+\$283	Specify leather color number.
• Select Surfaces leather price group 1	+\$283	► See <i>Surface Materials Reference Manual</i> .
• Steelcase vinyl	+\$ 26	Specify vinyl color number.
• Elmosoft leather upholstery	+\$337	Specify Elmosoft leather color number.
• Select Surfaces leather price group 2	+\$337	► See <i>Surface Materials Reference Manual</i> .
• Customer's Own Material (COM)	No cost	► See <i>Surface Materials Reference Manual</i> .
• Customer's Own Leather (COL)	+\$ 77	Specify leather color number.
Soil-retardant treatment	+\$ 25	Specify with soil-retardant treatment.
Personal Worksurface		
• Omit personal worksurface	-\$461	Specify with no worksurface.
Power		
• Omit power	-\$282	Specify with no power.
• Thread low profile plug	+\$ 26	Specify with Thread low profile plug.
• One USB 2.0 outlet and one NEMA three-prong outlet	+\$ 95	Specify with USB and standard NEMA three-prong outlet.
dash mini LED light		
• Paint price group 1	+\$431	Specify with light and indicate paint color number.
• Paint price group 3	+\$460	Specify with light and indicate paint color number.
		► See <i>Surface Materials Reference Manual</i> for accent paint options.
Related Products	• Footrest	► Page 274

Tip: The light option is only available if power has been specified.

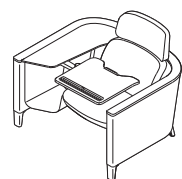

Specification Information

Style Number	Base Price
488WO	\$3049

Brody Privacy Lounge

SIN 711.16

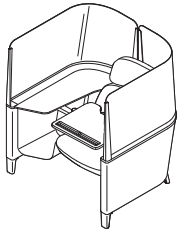

Tip: Illustration above shows right-hand privacy lounge.

Tip: For more information regarding color schemes, see page 247.

Tip: Handedness is determined by the side surface location. If specified as right-hand the side surface and storage will be on the user's right (as seated).

Tip: The trim is the top edge of the lower surround. If fabric trim is selected, the upholstery will match the upholstery specified on the lower surround.

Standard Includes		Required to Specify
<ul style="list-style-type: none"> ▶ Need help? Product details, page 244 	<ul style="list-style-type: none"> • Lower surround: fabric price group 1 • Screens: 6559 Satin Ice acrylic • Seat: fabric price group 1 • Side surface: laminate • Personal worksurface: plastic defaulted by color scheme • NEMA three prong power outlet: plastic defaulted by color scheme • Caddy: paint defaulted by color scheme 	<ol style="list-style-type: none"> 1 Style number 2 Color scheme (see below under Required Selections) 3 Left- or right-hand configuration (see below under Required Selections) 4 Fabric color number for upholstery on lower surround 5 Fabric color number for upholstery on seat 6 Laminate for side surface 7 Options, if selected (see below) <p>▶ See <i>Surface Materials</i>, page 432.</p>

Required Selections	Price	Required to Specify
Color Scheme Privacy lounge <ul style="list-style-type: none"> • Light • Medium • Dark • Matte copper • Matte brass • Burnished bronze • Night bronze • Obsidian 	<ul style="list-style-type: none"> No cost No cost No cost +\$315 +\$315 +\$315 +\$315 +\$315 	<ul style="list-style-type: none"> Specify with <i>light color scheme</i>. Specify with <i>medium color scheme</i>. Specify with <i>dark color scheme</i>. Specify with <i>matte copper color scheme</i>. Specify with <i>matte brass color scheme</i>. Specify with <i>burnished bronze color scheme</i>. Specify with <i>night bronze color scheme</i>. Specify with <i>obsidian color scheme</i>.

Handedness <ul style="list-style-type: none"> • Left • Right 	<ul style="list-style-type: none"> No cost No cost 	<ul style="list-style-type: none"> Specify with <i>left-hand side surface and storage location</i>. Specify with <i>right-hand side surface and storage location</i>.
---	--	---

Options	Price	Required to Specify
Surface Materials Upholstery on lower surround <ul style="list-style-type: none"> • Fabric price group 1 • Fabric price group 2 • Fabric price group 3 • Fabric price group 4 • Fabric price group 5 • Fabric price group 6 • Fabric price group 7 • Fabric price group 8 • Fabric price group 9 • Fabric price group 10 • Customer's Own Material (COM) 	<ul style="list-style-type: none"> No cost +\$ 47 +\$ 88 +\$124 +\$156 +\$194 +\$221 +\$280 +\$344 +\$391 No cost 	<ul style="list-style-type: none"> Specify fabric color number. Specify fabric color number. Specify fabric color number. Specify fabric color number. Specify fabric color number. Specify fabric color number. Specify fabric color number. Specify fabric color number. Specify fabric color number. Specify fabric color number. ▶ See <i>Surface Materials Reference Manual</i>.
Trim <ul style="list-style-type: none"> • Plastic • Fabric to match lower surround 	<ul style="list-style-type: none"> No cost +\$256 	<ul style="list-style-type: none"> Specify with <i>plastic trim</i>. Specify with <i>fabric trim</i>.
Upholstery on trim <ul style="list-style-type: none"> • Fabric price group 1 • Fabric price group 2 • Fabric price group 3 • Fabric price group 4 • Fabric price group 5 • Fabric price group 6 • Fabric price group 7 • Fabric price group 8 • Fabric price group 9 • Fabric price group 10 • Customer's Own Material (COM) 	<ul style="list-style-type: none"> No cost +\$ 17 +\$ 32 +\$ 45 +\$ 56 +\$ 71 +\$ 81 +\$101 +\$125 +\$142 No cost 	<ul style="list-style-type: none"> Specify fabric color number. Specify fabric color number. Specify fabric color number. Specify fabric color number. Specify fabric color number. Specify fabric color number. Specify fabric color number. Specify fabric color number. Specify fabric color number. Specify fabric color number.

▶ Options, continued on next page

▶ Detailed dimensions, page 250

► Options, continued from previous page

	Options	Price	Required to Specify
Surface Materials, continued	Upholstery on seat		
	• Fabric price group 1	No cost	Specify fabric color number.
	• Fabric price group 2	+\$ 26	Specify fabric color number.
	• Fabric price group 3	+\$ 48	Specify fabric color number.
	• Fabric price group 4	+\$ 68	Specify fabric color number.
	• Fabric price group 5	+\$ 85	Specify fabric color number.
	• Fabric price group 6	+\$106	Specify fabric color number.
	• Fabric price group 7	+\$121	Specify fabric color number.
	• Fabric price group 8	+\$153	Specify fabric color number.
	• Fabric price group 9	+\$188	Specify fabric color number.
	• Fabric price group 10	+\$213	Specify fabric color number.
	• Steelcase leather upholstery	+\$283	Specify leather color number.
	• Select Surfaces leather price group 1	+\$283	► See <i>Surface Materials Reference Manual</i> .
	• Steelcase vinyl	+\$ 26	Specify vinyl color number.
	• Elmosoft leather upholstery	+\$337	Specify Elmosoft leather color number.
• Select Surfaces leather price group 2	+\$337	► See <i>Surface Materials Reference Manual</i> .	
• Customer's Own Material (COM)	No cost	► See <i>Surface Materials Reference Manual</i> .	
• Customer's Own Leather (COL)	+\$ 77	Specify leather color number.	
	Soil-retardant treatment	+\$ 25	Specify with soil-retardant treatment.
	Screen type		
	• Acrylic	No cost	Specify with 6559 Satin Ice acrylic.
	• Fabric – 1 screen	+\$205	Specify with fabric screen.
	• Fabric – 2 screens	+\$410	Specify with fabric screens.
	Upholstery on screen		
	• Fabric price group 1	No cost	Specify fabric color number.
	• Fabric price group 2	+\$ 30	Specify fabric color number.
	• Fabric price group 3	+\$ 56	Specify fabric color number.
	• Fabric price group 4	+\$ 79	Specify fabric color number.
	• Fabric price group 5	+\$ 99	Specify fabric color number.
	• Fabric price group 6	+\$123	Specify fabric color number.
	• Fabric price group 7	+\$141	Specify fabric color number.
	• Fabric price group 8	+\$178	Specify fabric color number.
	• Fabric price group 9	+\$219	Specify fabric color number.
	• Fabric price group 10	+\$249	Specify fabric color number.
	• Customer's Own Material (COM)	No cost	► See <i>Surface Materials Reference Manual</i> .
	Omit Screen		
	• Omit right screen	–\$384	Specify with left screen location only.
	• Omit left screen	–\$384	Specify with right screen location only.
	Personal Worksurface		
	• Omit personal worksurface	–\$461	Specify with no worksurface.
	Power		
	• Omit power	–\$282	Specify with no power.
	• Thread low profile plug	+\$ 26	Specify with Thread low profile plug.
	• One USB 2.0 outlet and one NEMA three-prong outlet	+\$ 95	Specify with USB and standard NEMA three-prong outlet.
	dash mini LED light		
	• Paint price group 1	+\$431	Specify with light and indicate paint color number.
	• Paint price group 3	+\$460	Specify with light and indicate paint color number.
			► See <i>Surface Materials Reference Manual</i> for accent paint options.
	Related Products		► Page 274
	• Footrest		

► Specification Information, on next page

Tip: When omitting one fabric screen on a privacy lounge, the upholstery upcharge will be reduced by one half.

Tip: Buzz2 is the only Steelcase vertical upholstery group available on fabric screens.

Tip: COM selections are strictly limited, please reference the COM page at www.steelcase.com to make your selections.

Tip: When omitting a screen, only the screen opposite the side surface can be omitted.

Tip: The light option is only available if power has been specified.

Brody Privacy Lounge, continued

SIN 711.16

► Options, on previous page

Specification Information

• Style • Number	• Base • Price
488WP	\$3920

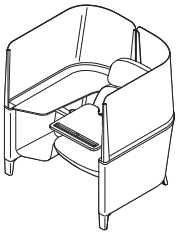

SIN 711.16

Brody Privacy Lounge with Extension

SIN 711.16

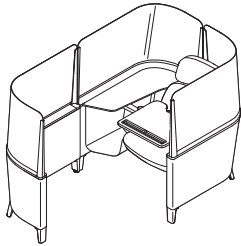

Tip: Illustration above shows right-hand privacy lounge with extension.

Tip: For more information regarding color schemes, see page 191.

Tip: Handedness is determined by the side surface location. If specified as right-hand the side surface and storage will be on the user's right (as seated).

Tip: The trim is the top edge of the lower surround. If fabric trim is selected, the upholstery will match the upholstery specified on the lower surround.

► Detailed dimensions, page 250

Standard Includes		Required to Specify
► Need help? Product details, page 244	<ul style="list-style-type: none"> Lower surround: fabric price group 1 Screens: 6559 Satin Ice acrylic Seat: fabric price group 1 Side surface: laminate Personal worksurface: plastic defaulted by color scheme NEMA three prong power outlet: plastic defaulted by color scheme Caddy: paint defaulted by color scheme 	<ol style="list-style-type: none"> Style number Color scheme (see below under Required Selections) Left- or right-hand configuration (see below under Required Selections) Fabric color number for upholstery on lower surround Fabric color number for upholstery on seat Laminate for side surface Options, if selected (see below) <p>► See <i>Surface Materials</i>, page 432.</p>

Required Selections	Price	Required to Specify
Color Scheme	Privacy lounge with extension	
<ul style="list-style-type: none"> Light Medium Dark Matte copper Matte brass Burnished bronze 	<ul style="list-style-type: none"> No cost No cost No cost +\$315 +\$315 +\$315 	<ul style="list-style-type: none"> Specify with <i>light color scheme</i>. Specify with <i>medium color scheme</i>. Specify with <i>dark color scheme</i>. Specify with <i>matte copper color scheme</i>. Specify with <i>matte brass color scheme</i>. Specify with <i>burnished bronze color scheme</i>.
	<ul style="list-style-type: none"> Night bronze Obsidian 	<ul style="list-style-type: none"> +\$315 +\$315 <ul style="list-style-type: none"> Specify with <i>night bronze color scheme</i>. Specify with <i>obsidian color scheme</i>.
Handedness	<ul style="list-style-type: none"> Left Right 	<ul style="list-style-type: none"> No cost No cost <ul style="list-style-type: none"> Specify with <i>left-hand side surface and storage location</i>. Specify with <i>right-hand side surface and storage location</i>.

Options	Price	Required to Specify
Surface Materials	Upholstery on lower surround	
<ul style="list-style-type: none"> Fabric price group 1 Fabric price group 2 Fabric price group 3 Fabric price group 4 Fabric price group 5 Fabric price group 6 Fabric price group 7 Fabric price group 8 Fabric price group 9 Fabric price group 10 Customer's Own Material (COM) 	<ul style="list-style-type: none"> No cost +\$ 77 +\$145 +\$203 +\$255 +\$317 +\$363 +\$458 +\$563 +\$640 No cost 	<ul style="list-style-type: none"> Specify fabric color number. Specify fabric color number. Specify fabric color number. Specify fabric color number. Specify fabric color number. Specify fabric color number. Specify fabric color number. Specify fabric color number. Specify fabric color number. Specify fabric color number. Specify fabric color number. <p>► See <i>Surface Materials Reference Manual</i></p>
	Trim	
<ul style="list-style-type: none"> Plastic Fabric to match lower surround 	<ul style="list-style-type: none"> No cost +\$384 	<ul style="list-style-type: none"> Specify with <i>plastic trim</i>. Specify with <i>fabric trim</i>.
	Upholstery on trim	
<ul style="list-style-type: none"> Fabric price group 1 Fabric price group 2 Fabric price group 3 Fabric price group 4 Fabric price group 5 Fabric price group 6 Fabric price group 7 Fabric price group 8 Fabric price group 9 Fabric price group 10 Customer's Own Material (COM) 	<ul style="list-style-type: none"> No cost +\$ 27 +\$ 48 +\$ 68 +\$ 85 +\$107 +\$122 +\$153 +\$188 +\$214 No cost 	<ul style="list-style-type: none"> Specify fabric color number. Specify fabric color number. Specify fabric color number. Specify fabric color number. Specify fabric color number. Specify fabric color number. Specify fabric color number. Specify fabric color number. Specify fabric color number. Specify fabric color number.

► Options, continued on next page

► Options, continued from previous page

	Options	Price	Required to Specify	
Surface Materials, continued	Upholstery on seat			
	• Fabric price group 1	No cost	Specify fabric color number.	
	• Fabric price group 2	+\$ 26	Specify fabric color number.	
	• Fabric price group 3	+\$ 48	Specify fabric color number.	
	• Fabric price group 4	+\$ 68	Specify fabric color number.	
	• Fabric price group 5	+\$ 85	Specify fabric color number.	
	• Fabric price group 6	+\$106	Specify fabric color number.	
	• Fabric price group 7	+\$121	Specify fabric color number.	
	• Fabric price group 8	+\$153	Specify fabric color number.	
	• Fabric price group 9	+\$188	Specify fabric color number.	
	• Fabric price group 10	+\$213	Specify fabric color number.	
	• Steelcase leather upholstery	+\$283	Specify leather color number.	
	• Select Surfaces leather price group 1	+\$283	► See <i>Surface Materials Reference Manual</i> .	
	• Elmosoft leather upholstery	+\$337	Specify Elmosoft leather color number.	
• Select Surfaces leather price group 2	+\$337	► See <i>Surface Materials Reference Manual</i> .		
• Steelcase vinyl	+\$ 26	Specify vinyl color number.		
• Customer's Own Material (COM)	No cost	► See <i>Surface Materials Reference Manual</i> .		
• Customer's Own Leather (COL)	+\$ 77	Specify leather color number.		
	Soil-retardant treatment	+\$ 25	Specify with soil-retardant treatment.	
	Screen type			
	• Acrylic	No cost	Specify with 6559 Satin Ice acrylic.	
	• Fabric – 2 screens	+\$410	Specify with fabric screens.	
	• Fabric – 3 screens	+\$615	Specify with fabric screens.	
	Upholstery on screen			
	• Fabric price group 1	No cost	Specify fabric color number.	
	• Fabric price group 2	+\$ 30	Specify fabric color number.	
	• Fabric price group 3	+\$ 56	Specify fabric color number.	
	• Fabric price group 4	+\$ 79	Specify fabric color number.	
	• Fabric price group 5	+\$ 99	Specify fabric color number.	
	• Fabric price group 6	+\$123	Specify fabric color number.	
	• Fabric price group 7	+\$141	Specify fabric color number.	
	• Fabric price group 8	+\$178	Specify fabric color number.	
	• Fabric price group 9	+\$219	Specify fabric color number.	
	• Fabric price group 10	+\$249	Specify fabric color number.	
	• Customer's Own Material (COM)	No cost	► See <i>Surface Materials Reference Manual</i> .	
	Omit Screen			
	• Omit right screen	–\$384	Specify with left screen location only.	
	• Omit left screen	–\$384	Specify with right screen location only.	
	Personal Worksurface	• Omit personal worksurface	–\$461	Specify with no worksurface.
	Power			
	• Omit power	–\$282	Specify with no power.	
	• Thread low profile plug	+\$ 26	Specify with Thread low profile plug.	
	• One USB 2.0 outlet and one NEMA three-prong outlet	+\$ 95	Specify with USB and standard NEMA three-prong outlet.	
	dash mini LED light			
	• Paint price group 1	+\$431	Specify with light and indicate paint color number.	
	• Paint price group 3	+\$460	Specify with light and indicate paint color number.	
			► See <i>Surface Materials Reference Manual</i> for accent paint options.	
	Related Products	• Footrest	► Page 274	

► Specification Information, on next page

Tip: When omitting one fabric screen on a privacy lounge with extension, the upholstery upcharge will be reduced by one third.

Tip: Buzz2 is the only Steelcase vertical upholstery group available on fabric screens.

Tip: COM selections are strictly limited, please reference the COM page at www.steelcase.com to make your selections.

Tip: When omitting a screen, only the screen opposite the side surface can be omitted.

Tip: The light option is only available if power has been specified.

Brody Privacy Lounge with Extension, continued

SIN 711.16

► Options, on previous page

Specification Information

• Style • Number	• Base • Price
488WE	\$5294
.	.

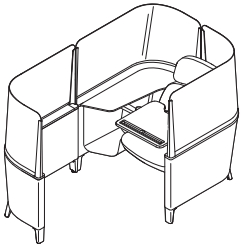

Seating

Brody Privacy
Lounge with Extension

SIN 711.16

Brody 488 Series

Brody Privacy Desk

SIN 711.16

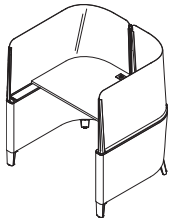

Tip: For more information regarding color schemes, see page 256.

For laminate price group 2 pricing, please refer to the electronic catalog or SmartTools.

Standard Includes	Required to Specify
<ul style="list-style-type: none"> ▶ Need help? Product details, page 254 • Lower surround: fabric price group 1 • Screens: 6559 Satin Ice acrylic • Worksurface: High-Pressure Laminate price group 1 • Edge: plastic • NEMA three prong power outlet: paint • Wire management clips 	<ol style="list-style-type: none"> 1 Style number 2 Color scheme (see below under Required Selections) 3 Fabric color number for upholstery on lower surround 4 High-Pressure Laminate color number for worksurface 5 Plastic color number for worksurface edge 6 Paint color number for power outlet 7 Options, if selected (see below) <p>▶ See <i>Surface Materials</i>, page 432.</p>

Required Selections	Price	Required to Specify
Color Scheme		
• Light	No cost	Specify with <i>light color scheme</i> .
• Medium	No cost	Specify with <i>medium color scheme</i> .
• Dark	No cost	Specify with <i>dark color scheme</i> .
• Matte copper	+\$315	Specify with <i>matte copper color scheme</i> .
• Matte brass	+\$315	Specify with <i>matte brass color scheme</i> .
• Burnished bronze	+\$315	Specify with <i>burnished bronze color scheme</i> .
• Night bronze	+\$315	Specify with <i>night bronze color scheme</i> .
• Obsidian	+\$315	Specify with <i>obsidian color scheme</i> .

Options	Price	Required to Specify
Surface Materials		
High-Pressure Laminate worksurface		
• High-Pressure Laminate price group 2	See information at left	Specify laminate color number.
• Open Line laminate	+\$ 69 plus cost of laminate	▶ See <i>Surface Materials Reference Manual</i> .
Wood veneer worksurface		
• Wood veneer	+\$750	Specify with <i>wood veneer</i> and indicate wood color number.
• Premium wood 2	+\$798	Specify Premium wood 2 finish number.
• Premium wood 3	+\$919	Specify Premium wood 3 finish number.
• Customiz stain	No cost	Specify with <i>Customiz stain</i> .
• Full-fill finish	+\$789	▶ See <i>Surface Materials Reference Manual</i> . Specify full-fill finish number.
Upholstery on lower surround		
• Fabric price group 1	No cost	Specify fabric color number.
• Fabric price group 2	+\$ 47	Specify fabric color number.
• Fabric price group 3	+\$ 88	Specify fabric color number.
• Fabric price group 4	+\$124	Specify fabric color number.
• Fabric price group 5	+\$156	Specify fabric color number.
• Fabric price group 6	+\$194	Specify fabric color number.
• Fabric price group 7	+\$221	Specify fabric color number.
• Fabric price group 8	+\$280	Specify fabric color number.
• Fabric price group 9	+\$344	Specify fabric color number.
• Fabric price group 10	+\$391	Specify fabric color number.
• Customer's Own Material (COM)	No cost	▶ See <i>Surface Materials Reference Manual</i> .

▶ Options, continued on next page

SIN 711.16

► Options, continued from previous page

Options	Price	Required to Specify
Surface Materials, continued		
Trim		
• Plastic	No cost	Specify with plastic trim.
• Fabric to match lower surround	+\$256	Specify with fabric trim.
Upholstery on trim		
• Fabric price group 1	No cost	Specify fabric color number.
• Fabric price group 2	+\$ 17	Specify fabric color number.
• Fabric price group 3	+\$ 32	Specify fabric color number.
• Fabric price group 4	+\$ 45	Specify fabric color number.
• Fabric price group 5	+\$ 56	Specify fabric color number.
• Fabric price group 6	+\$ 71	Specify fabric color number.
• Fabric price group 7	+\$ 81	Specify fabric color number.
• Fabric price group 8	+\$101	Specify fabric color number.
• Fabric price group 9	+\$125	Specify fabric color number.
• Fabric price group 10	+\$142	Specify fabric color number.
• Customer's Own Material (COM)	No cost	► See Surface Materials Reference Manual.
Screen type		
• Acrylic	No cost	Specify with 6559 Satin Ice acrylic.
• Fabric	+\$410	Specify with fabric screens.
Upholstery on screen		
• Fabric price group 1	No cost	Specify fabric color number.
• Fabric price group 2	+\$ 30	Specify fabric color number.
• Fabric price group 3	+\$ 56	Specify fabric color number.
• Fabric price group 4	+\$ 79	Specify fabric color number.
• Fabric price group 5	+\$ 99	Specify fabric color number.
• Fabric price group 6	+\$123	Specify fabric color number.
• Fabric price group 7	+\$141	Specify fabric color number.
• Fabric price group 8	+\$178	Specify fabric color number.
• Fabric price group 9	+\$219	Specify fabric color number.
• Fabric price group 10	+\$249	Specify fabric color number.
• Customer's Own Material (COM)	No cost	► See Surface Materials Reference Manual.
Power		
• Omit power	-\$282	Specify with no power.
• Thread low profile plug	+\$ 26	Specify with Thread low profile plug and indicate paint color number.
• One USB 2.0 outlet and one NEMA three-prong outlet	+\$ 95	Specify with USB and standard NEMA three-prong outlet and indicate paint color number.
dash mini LED light		
• Paint price group 1	+\$431	Specify with light and indicate paint color number.
• Paint price group 3	+\$460	Specify with light and indicate paint color number.
		► See Surface Materials Reference Manual.

Tip: The trim is the top edge of the lower surround. If fabric trim is selected, the upholstery will match the upholstery specified on the lower surround.

Tip: Buzz2 is the only Steelcase vertical upholstery group available on fabric screens.

Tip: COM selections are strictly limited, please reference the COM page at www.steelcase.com to make your selections.

Tip: The light option is only available if power has been specified.

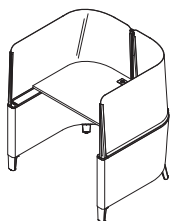

Specification Information

Style Number	Base Price
488BD	\$3648

Brody 488 Series

Brody Privacy Desk with Extension

SIN 711.16

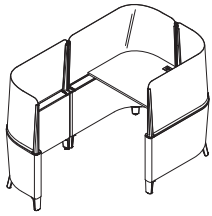

Tip: Illustration above shows privacy desk with extension, enter right.

Tip: For more information regarding color schemes, see page 256.

Tip: Extension opening is determined by where the user enters Brody desk unit.

For laminate price group 2 pricing, please refer to the electronic catalog or SmartTools.

Standard Includes	Required to Specify
<ul style="list-style-type: none"> ▶ Need help? Product details, page 254 • Lower surround: fabric price group 1 • Screens: 6559 Satin Ice acrylic • Worksurface: High-Pressure Laminate price group 1 • Edge: plastic • NEMA three prong power outlet: paint • Wire management clips 	<ol style="list-style-type: none"> 1 Style number 2 Color scheme (see below under Required Selections) 3 Extension opening (see below under Required Selections) 4 Fabric color number for upholstery on lower surround 5 High-Pressure Laminate color number for worksurface 6 Plastic color number for worksurface edge 7 Paint color number for power outlet 8 Options, if selected (see below) <p>▶ See <i>Surface Materials</i>, page 432.</p>

	Required Selections	Price	Required to Specify
Color Scheme	• Light	No cost	Specify with <i>light color scheme</i> .
	• Medium	No cost	Specify with <i>medium color scheme</i> .
Extension Opening	• Dark	No cost	Specify with <i>dark color scheme</i> .
	• Matte copper	+\$315	Specify with <i>matte copper color scheme</i> .
	• Matte brass	+\$315	Specify with <i>matte brass color scheme</i> .
	• Burnished bronze	+\$315	Specify with <i>burnished bronze color scheme</i> .
	• Night bronze	+\$315	Specify with <i>night bronze color scheme</i> .
	• Obsidian	+\$315	Specify with <i>obsidian color scheme</i> .
	• Enter left	No cost	Specify with <i>enter left</i> .
• Enter right	No cost	Specify with <i>enter right</i> .	

	Options	Price	Required to Specify
Surface Materials	High-Pressure Laminate worksurface		
	• High-Pressure Laminate price group 2	See information at left	Specify laminate color number.
	• Open Line laminate	+\$ 69 plus cost of laminate	▶ See <i>Surface Materials Reference Manual</i> .
	Wood veneer worksurface		
	• Wood veneer	+\$750	Specify with <i>wood veneer</i> and indicate wood color number.
	• Premium wood 2	+\$798	Specify Premium wood 2 finish number.
	• Premium wood 3	+\$919	Specify Premium wood 3 finish number.
	• Customiz stain	No cost	Specify with <i>Customiz stain</i> .
	• Full-fill finish	+\$789	▶ See <i>Surface Materials Reference Manual</i> . Specify full-fill finish number.
	Upholstery on lower surround		
	• Fabric price group 1	No cost	Specify fabric color number.
	• Fabric price group 2	+\$ 77	Specify fabric color number.
	• Fabric price group 3	+\$145	Specify fabric color number.
	• Fabric price group 4	+\$203	Specify fabric color number.
	• Fabric price group 5	+\$255	Specify fabric color number.
	• Fabric price group 6	+\$317	Specify fabric color number.
	• Fabric price group 7	+\$363	Specify fabric color number.
	• Fabric price group 8	+\$458	Specify fabric color number.
	• Fabric price group 9	+\$563	Specify fabric color number.
	• Fabric price group 10	+\$640	Specify fabric color number.
	• Customer's Own Material (COM)	No cost	▶ See <i>Surface Materials Reference Manual</i> .

▶ Options, continued on next page

► Options, continued from previous page

Options	Price	Required to Specify
Surface Materials, continued		
Trim		
• Plastic	No cost	Specify with <i>plastic trim</i> .
• Fabric to match lower surround	+\$384	Specify with <i>fabric trim</i> .
Upholstery on trim		
• Fabric price group 1	No cost	Specify fabric color number.
• Fabric price group 2	+\$ 27	Specify fabric color number.
• Fabric price group 3	+\$ 48	Specify fabric color number.
• Fabric price group 4	+\$ 68	Specify fabric color number.
• Fabric price group 5	+\$ 85	Specify fabric color number.
• Fabric price group 6	+\$107	Specify fabric color number.
• Fabric price group 7	+\$122	Specify fabric color number.
• Fabric price group 8	+\$153	Specify fabric color number.
• Fabric price group 9	+\$188	Specify fabric color number.
• Fabric price group 10	+\$214	Specify fabric color number.
• Customer's Own Material (COM)	No cost	► See <i>Surface Materials Reference Manual</i> .
Screen type		
• Acrylic	No cost	Specify with <i>6559 Satin Ice acrylic</i> .
• Fabric	+\$615	Specify with <i>fabric screens</i> .
Upholstery on screen		
• Fabric price group 1	No cost	Specify fabric color number.
• Fabric price group 2	+\$ 30	Specify fabric color number.
• Fabric price group 3	+\$ 56	Specify fabric color number.
• Fabric price group 4	+\$ 79	Specify fabric color number.
• Fabric price group 5	+\$ 99	Specify fabric color number.
• Fabric price group 6	+\$123	Specify fabric color number.
• Fabric price group 7	+\$141	Specify fabric color number.
• Fabric price group 8	+\$178	Specify fabric color number.
• Fabric price group 9	+\$219	Specify fabric color number.
• Fabric price group 10	+\$249	Specify fabric color number.
• Customer's Own Material (COM)	No cost	► See <i>Surface Materials Reference Manual</i> .
Power		
• Omit power	-\$282	Specify with <i>no power</i> .
• Thread low profile plug	+\$ 26	Specify with <i>Thread low profile plug</i> and indicate paint color number.
• One USB 2.0 outlet and one NEMA three-prong outlet	+\$ 95	Specify with <i>USB and standard NEMA three-prong outlet</i> and indicate paint color number.
dash mini LED light		
• Paint price group 1	+\$431	Specify with <i>light</i> and indicate paint color number.
• Paint price group 3	+\$460	Specify with <i>light</i> and indicate paint color number.
		► See <i>Surface Materials Reference Manual</i> .

Tip: The trim is the top edge of the lower surround. If fabric trim is selected, the upholstery will match the upholstery specified on the lower surround.

Tip: Buzz2 is the only Steelcase vertical upholstery group available on fabric screens.

Tip: COM selections are strictly limited, please reference the COM page at www.steelcase.com to make your selections.

Tip: The light option is only available if power has been specified.

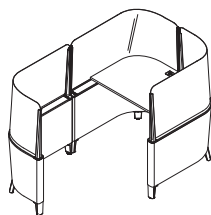

Specification Information

Style Number	Base Price
488BDE	\$5022

Brody Footrest

SIN 711.16



Standard Includes	Required to Specify
<ul style="list-style-type: none"> ▶ Need help? Product details, page 244 • Lower footrest: plastic • Upper footrest: fabric price group 1 	<ol style="list-style-type: none"> 1 Style number 2 Fabric color number for upper footrest 3 Plastic color number for lower footrest: 6053 Seagull, 6059 Sterling Dark 4 Options, if selected (see below) <ul style="list-style-type: none"> ▶ See <i>Surface Materials</i>, page 432.

Options	Price	Required to Specify
Surface Materials Upholstery on upper footrest <ul style="list-style-type: none"> • Fabric price group 1 • Fabric price group 2 • Fabric price group 3 • Fabric price group 4 • Fabric price group 5 • Fabric price group 6 • Fabric price group 7 • Fabric price group 8 • Fabric price group 9 • Fabric price group 10 • Steelcase leather upholstery • Select Surfaces leather price group 1 • Elmosoft leather upholstery • Select Surfaces leather price group 2 • Steelcase vinyl • Customer's Own Material (COM) • Customer's Own Leather (COL) 	<ul style="list-style-type: none"> No cost +\$ 17 +\$ 32 +\$ 45 +\$ 56 +\$ 71 +\$ 81 +\$101 +\$125 +\$142 +\$189 +\$189 +\$224 +\$224 +\$ 17 No cost +\$ 37 	<ul style="list-style-type: none"> Specify fabric color number. Specify fabric color number. Specify fabric color number. Specify fabric color number. Specify fabric color number. Specify fabric color number. Specify fabric color number. Specify fabric color number. Specify fabric color number. Specify fabric color number. Specify leather color number. ▶ See <i>Surface Materials Reference Manual</i>. Specify Elmosoft leather color number. ▶ See <i>Surface Materials Reference Manual</i>. Specify vinyl color number. ▶ See <i>Surface Materials Reference Manual</i>. Specify leather color number.
Soil-retardant treatment	+\$ 25	Specify with soil-retardant treatment.
Plastic on upper footrest <ul style="list-style-type: none"> • Plastic 	+\$ 65	Specify with 6527 Merle.
Related Products <ul style="list-style-type: none"> • Brody 		▶ Pages 260–266

Specification Information	
• Style Number	• Base Price
488FR	\$311
.	.
.	.

Umami

Umami, with its flexible, modular design, can be used to create spaces that are unique to organizations and individuals. Multiple materials are used to promote variation and encourage creativity and self-expression. Integrated power, tables, and screens support the ability to perform in an open environment or in solitude.

► Specifying, pages 288-316

Umami screens are available in two heights for different privacy needs.

Integrated tables are available in two shapes and can be optioned on lounges and platforms.

Lounge seating is upholstered and attaches to other seating or platforms. Different styles allow for a variety of configurations and applications.

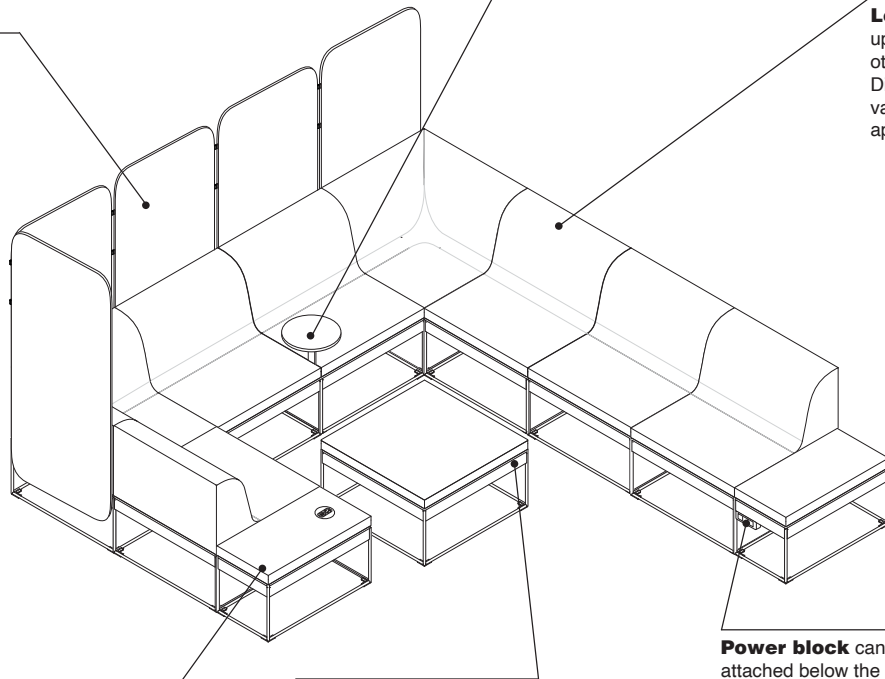

Platforms are available in different sizes with multiple materials available. They can be attached to lounge seating or other platforms to create tables or benches.

Fascia will match the top of the seat or platform unless the contrasting option is selected.

Power block can be attached below the frame anywhere along the lounge or platform. Power can also be integrated on single platforms with laminate or veneer tops (platform table power option).

Product Details

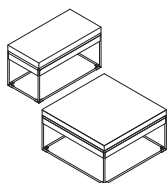

Single platforms come in 15"D x 30"W or 30"D x 30"W sizes. They are available in upholstery, laminate, or wood veneer.

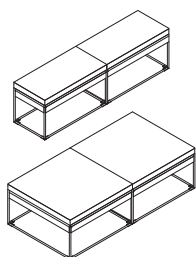

Double platforms come in 15"D x 60"W or 30"D x 60"W sizes. They are available in upholstery only.

Platforms can be ganged together or ganged to lounge seating.

When selecting contrasting option on platforms with depth of 15", the 15"D sides are the left and right sides. The front is either the 30"W side (if single platform), or 60"W side (if double platform).

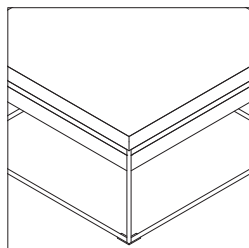

Glides come standard on the bottom of platform frame.

Lounges are available in five different shapes:

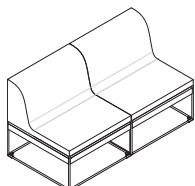
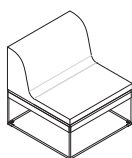

Straight lounge - single or double

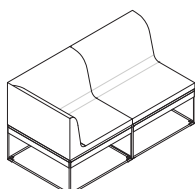
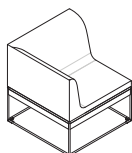

One arm lounge - single or double

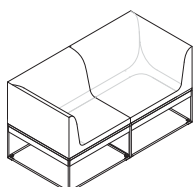

Two arm lounge - double

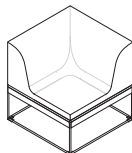

Corner lounge

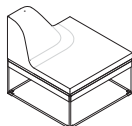

End cap lounge

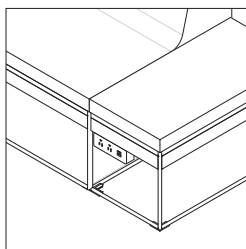

Lounge and platforms gang together with two bolts.



Screens are available at installed heights of 48" or 60".



Standard screens come in widths of 15" or 30".

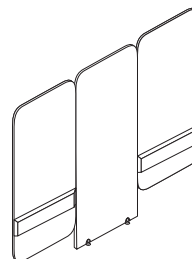

Spanner screens span across two lounge frames and an open space to create a cabin type application. They come in widths of 90" or 105". 90"W spanner screens come with (3) 30"W screens. 105"W spanner screens come with (2) 30"W screens and (1) 45"W center screen.

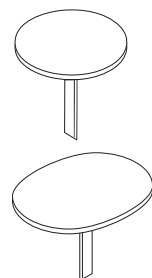

Round or pill tables can only be optioned on straight single, straight double, one arm double, and end cap lounge. Tables can be optioned on all upholstered top platforms except for 15"D x 30"W single platform and 15"D x 60"W double platform.

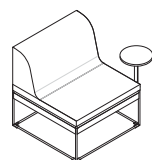

Tables are optioned as table left or table right (based on user sitting in lounge). Table right is shown above.

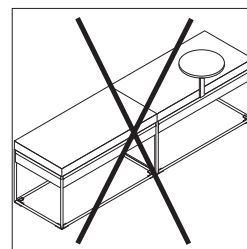

Tables may not be specified on 15"D x 30"W or 15"D x 60"W platforms.

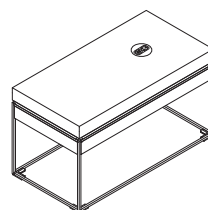

Platform table power can only be optioned on single platforms with laminate or veneer tops. It will be located at the center back of the platform top.

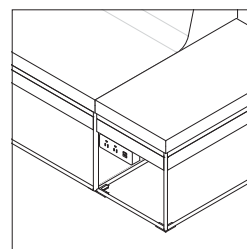

Power blocks can be installed anywhere along the bottom of the fascia on any platform or lounge.

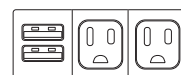

Power blocks and platform table power options come with three power or two power, one USB.

Umami, continued

Surface Materials

The fascia will match the top surface unless the contrasting option is specified.

If top of platform is fabric, the fascia cannot be a hard surface. It can only be upholstery.



Fascia grain direction will always match the sides of the platforms when selecting hard surfaces. On 15" D platforms, the grain is a waterfall on 15" sides.

When a platform has a hard surface and either laminate or veneer is selected, only monolithic and contrasting fascia options are available. Contrasting sides is not an option.

Only one contrasting surface option is available on each product. This includes fascia which is considered a contrasting surface. If more than one contrasting option is desired, please contact a specials representative.

When contrasting fascia is selected, the fascia will be contrasting from the tops.

Single platform

- Top and fascia
- Laminate
- Veneer
- Open Line laminate
- Customiz stain
- Fabric
- Vinyl
- Elmosoft leather
- COM

- Frame
- Paint
- Lux Coatings
- Accent paints
- PerfectMatch paint

Double platform

- Top and fascia
- Fabric
- Vinyl
- Elmosoft leather
- COM
- Frame
- Paint
- Lux Coatings
- Accent paints
- PerfectMatch paint

Lounge

- Top and fascia
- Fabric
- Vinyl
- Elmosoft leather
- COM
- Frame
- Paint
- Lux Coatings
- Accent paints
- PerfectMatch paint

Screen

- Fabric
- COM

Screen Clips

- 6053 Seagull
- 6527 Merle

Power block (option)

- Black

Platform table power (option)

- Silver

Round and pill table (option)

- Top
- Laminate

Support

- Paint

Solid, non-repeat fabrics are recommended for Umami lounge, platform, and screens. Steelcase will not pattern match fabrics which have a distinct repeating pattern (stripes, vertical repeats, etc). This includes pattern matching on the single unit but also pattern matching from one component to another. If pattern matching is of concern it is recommended to use one of the standard Steelcase fabrics, vinyls, or non-patterned COM.

Programs & Services

For more information on accent paints, Lux Coatings, PerfectMatch program, and Select Surfaces program, please refer to the *Surface Materials Reference Manual*.

The Customer's Own Material (COM) Program

offers the opportunity for customers to select fabrics that are not offered through the standard Steelcase surface materials program for use on Steelcase products. Through the COM program, Steelcase will test your materials for application on Steelcase products. Once approved, you can place your order. Steelcase will facilitate the entire ordering process and give you a production schedule. Steelcase will order the COM fabric directly from the textile manufacturer. For up-to-date information regarding fabric test results for all COM fabrics and details regarding yardage requirements for most Seating lines, visit the COM website. To locate the COM website:

- Visit www.steelcase.com

Contact your Steelcase Solutions Fulfillment Team Representative at 1.888.STEELCASE (1.888.783.3522) or send an email to lineone@steelcase.com.



Umami

Materiality

Umami screens can have contrasting fabrics on the inside and outside of the screen as long as they are in the same fabric family.

Spanner screens can have fabric applied vertically only.

Double platforms are available in upholstery only.

If the top of the platform is upholstered, the fascia must be upholstered.

Round or pill table tops are available in two laminates only (2HMG Merle and 2883 Seagull).

Integrated round or pill tables can only be optioned onto lounges or upholstered platforms.

If top of platform is a hard surface, the fascia may be upholstered, laminate, or veneer.

When optioning contrasting fascia, the fascia will be contrasting around the entire frame (all four sides).

Lounge seating fascia can only be ordered in upholstery. No hard surfaces on lounge or lounge fascia.

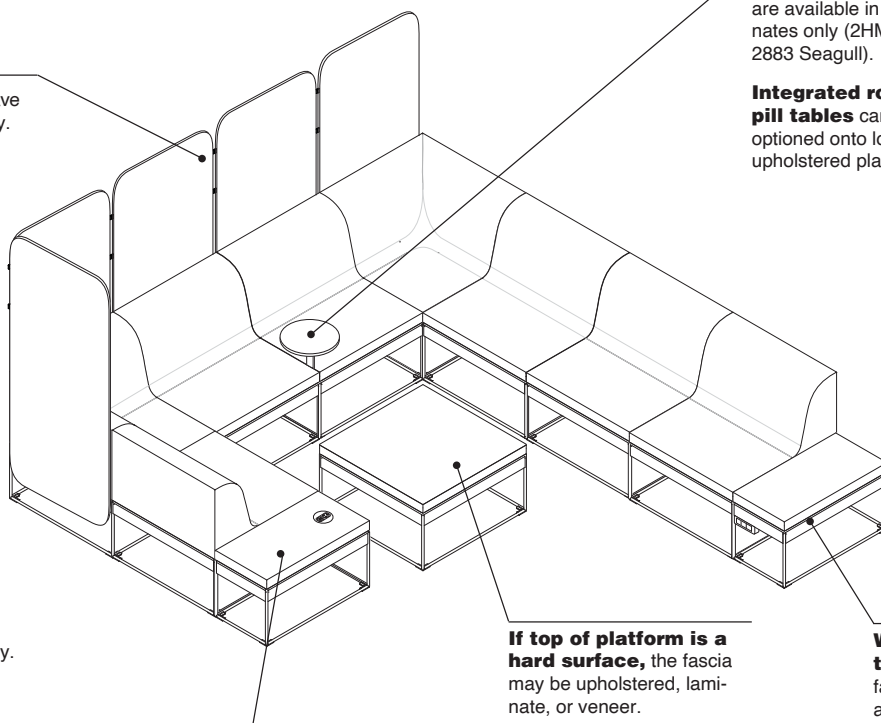

Contrasting Details

Single Platforms and Lounges

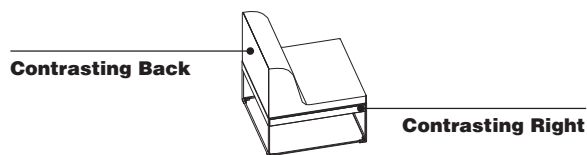
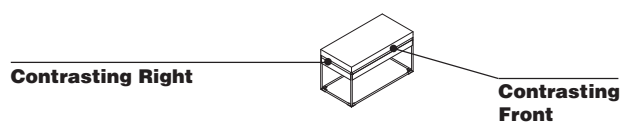

Single Platforms and Lounges

- Contrasting Front
- Contrasting Back
- Contrasting Front and Back
- Contrasting Left
- Contrasting Right
- Contrasting Left and Right

Only one contrasting selection can be made on each product. This includes contrasting fascia.

When a platform has a hard surface and either laminate or veneer is selected, only monolithic and contrasting fascia options are available. Contrasting sides is not an option.

Double Platforms and Lounges

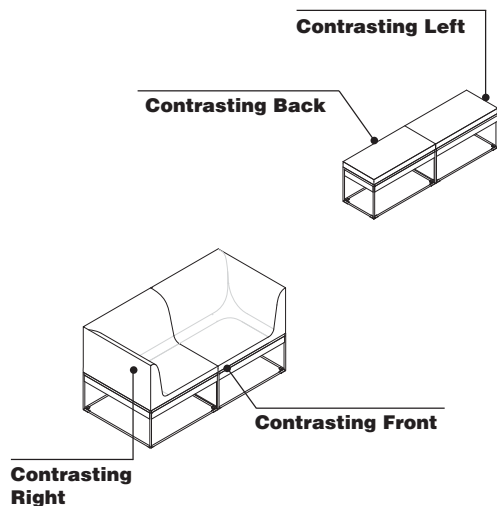

On 15"D platforms, the front is the 30"W or 60"W side. The left and right sides are 15"D.

Double Platforms and Lounges

- Contrasting Front
- Contrasting Back
- Contrasting Front and Back
- Contrasting Left
- Contrasting Right
- Contrasting Left and Right
- Contrasting Seam
- Contrasting Seam, Left and Right

Only one contrasting selection can be made on each product. This includes contrasting fascia.

Corner Lounge only

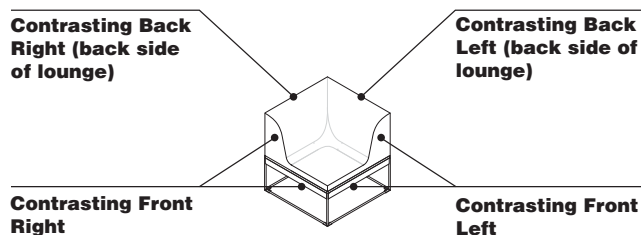

Corner Lounge only

- Contrasting Front Right and Front Left
- Contrasting Back Right and Back Left

Only one contrasting selection can be made on each product. This includes contrasting fascia.

Umami

Pill and Round Tables

Pill and round tables are options added as table left or table right (optioned based on user sitting in lounge).

Pill and round tables can be optioned on select platforms with upholstered top or on lounge products.

Round tables are 10" in diameter. Pill tables are 10" by 13 1/2".



The post (support) of the table is available in paint.



Table tops are available in 2883 Seagull and 2HMG Merle only.

Locations of round or pill tables are shown below.

Single Platforms

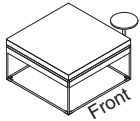

Left location

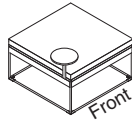

Right location

Round and pill tables cannot be attached to a 15"D x 30"W or 15"D x 60"W platform.

Double Platforms

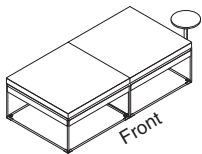

Left location

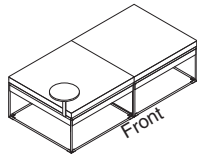

Right location

Round and pill tables cannot be attached to a 15"D x 60"W platform.

Straight Single Lounge

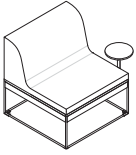

Left location

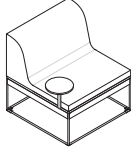

Right location

Round and pill tables cannot be attached to one arm single, two arm single, or corner lounge.

End Cap

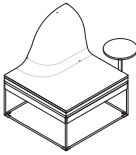

Left location

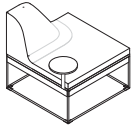

Right location

Straight Double Lounge

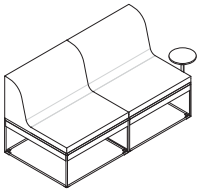

Left location

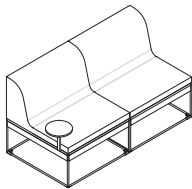

Right location

Round and pill tables cannot be attached to two arm double lounge.

One Arm Double Lounge

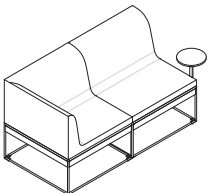

Left location

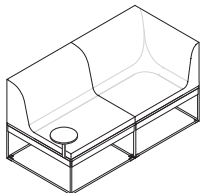

Right location

Umami

Screens

Standard screens are installed at 48" and 60" high.

Screens are available as standard fabric covered.

Each screen will come with one or two clips in merle or seagull that attach screens together.

Screen clips come in two types: straight or corner.

Standard come in 15" and 30" widths.

Fabrics on the screens can be ordered as contrasting. When ordering contrasting, fabrics must be in same fabric family.

Screens cannot be placed in between platforms and lounge seating.

Screens cannot be placed on the front of any platform or lounge seating.

30"W screen can only be put on a 15"D x 30"W platform if the platform is attached to another platform or lounge.

30"W screens can be placed on a 30"D platform/lounge or two 15"D platforms.

Spanner screens come in 90" and 105" widths and the center screen goes completely to the floor. They are not allowed to be attached to a platform or end cap lounge.

90"W spanner screens can only be attached to the side of two lounge chairs. They cannot be attached to an end cap lounge or platform.

15"W screens can go on an end of a lounge for partial privacy. In this case, an upholstered fascia must be added.

Two 15"W screens will not fit on a 30"D platform or lounge.

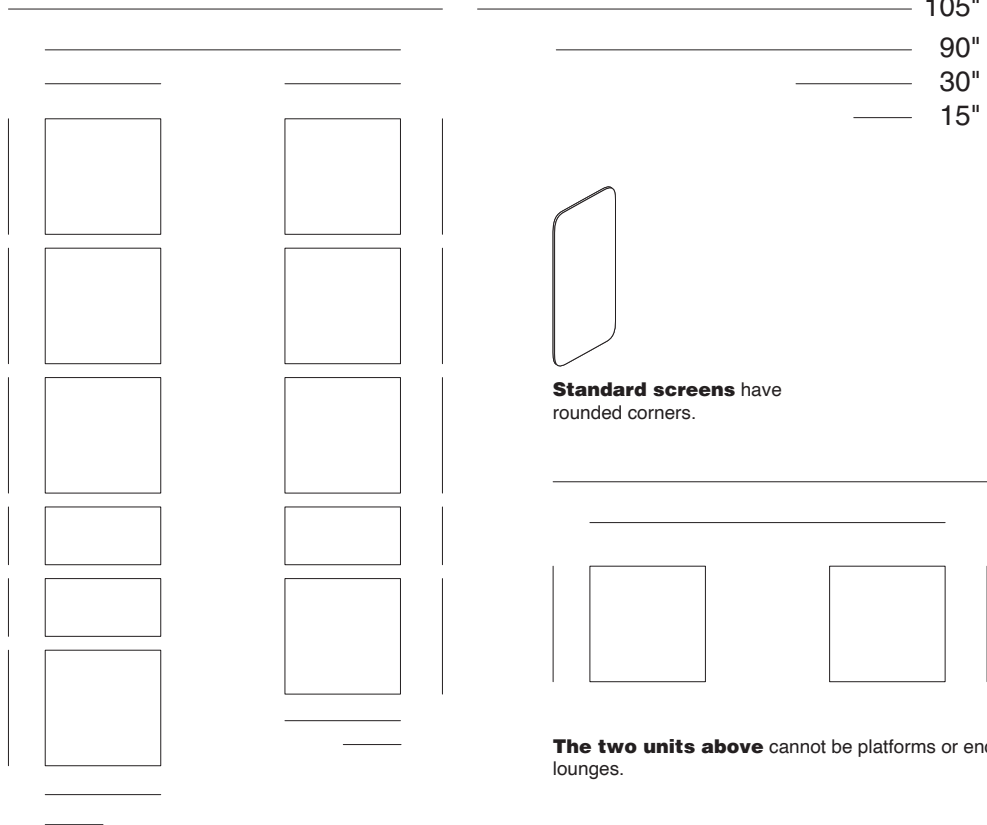

Standard screens have rounded corners.

The two units above cannot be platforms or end cap lounges.

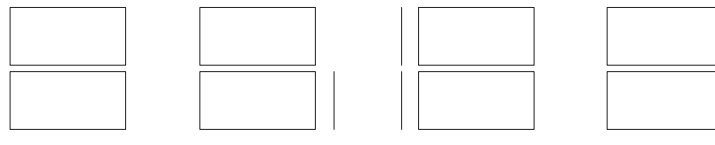
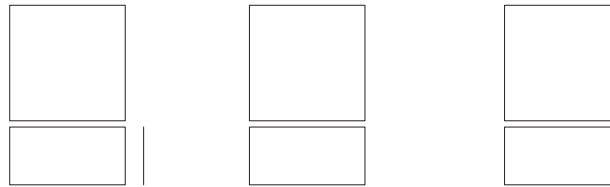

15"W and 30"W screens are only allowed on 15"D x 30"W frames in the shown above configurations.

Tip: When placing a 15"D screen on a 30"W frame, a fascia must be specified.

The following applications are not allowed:

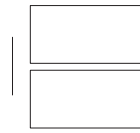
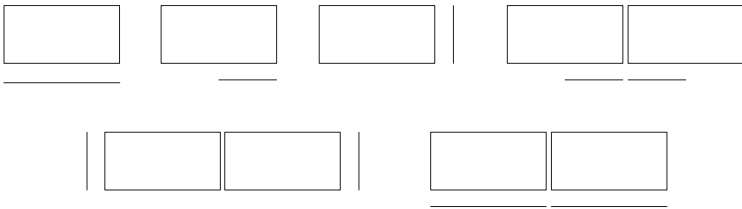

15"W screens cannot span two 15"D x 30"W units.

Specifications above are not allowed for stability reasons.

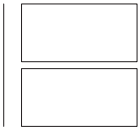

30"W screens cannot span two 15"D x 30"W units.



15"W screens cannot be mounted in the center of a 30"D x 30"W unit.

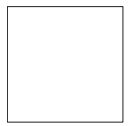

Two 15"W screens cannot be mounted to a 30"W unit.

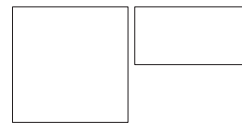

15"D units cannot be ganged to a 30"W frame on the 15"D side.

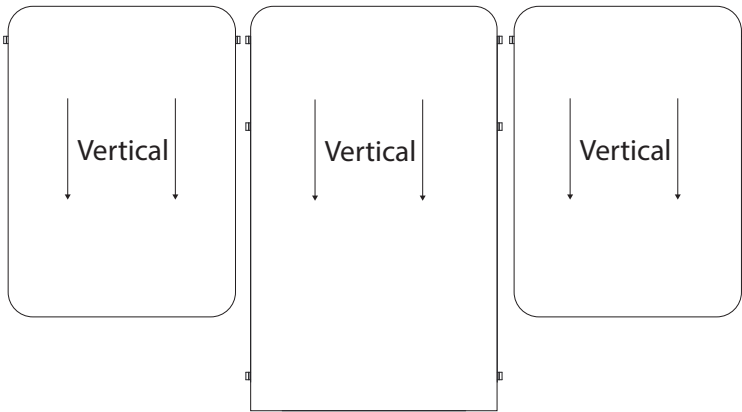

Fabrics can only be applied vertically on spanner screens. If you want other screens to match spanner screens, make sure to specify vertical application on standard screens.

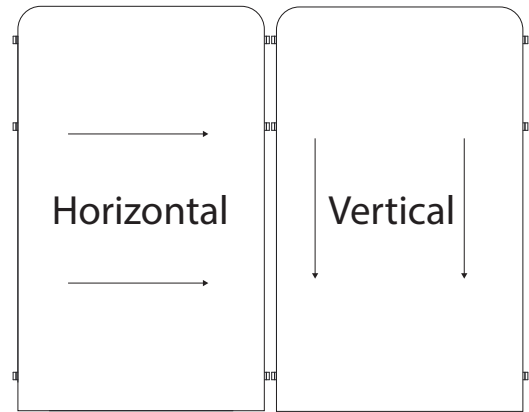

Fabrics can be applied either vertically or horizontally on standard screens.

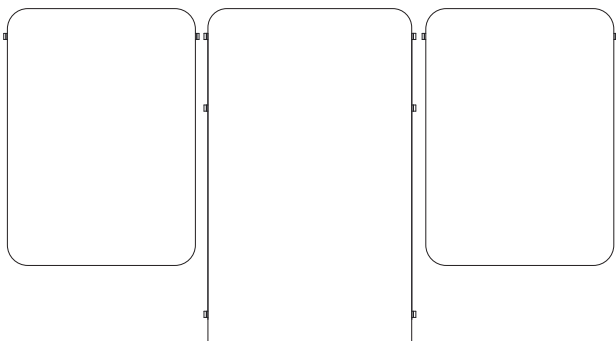

90"W spanner screens will come with three 30"W screens. The center screen will go completely to the floor.

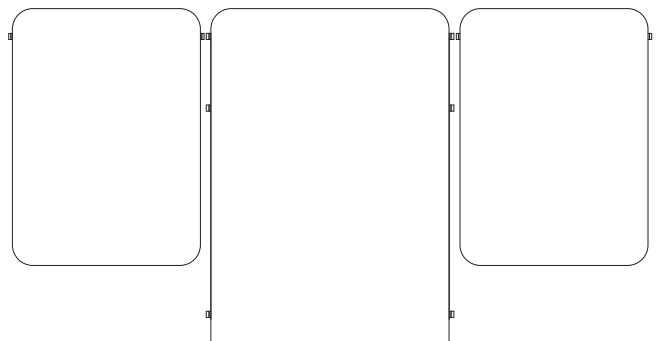

105"W spanner screens will come with two 30"W screens on the ends and a 45"W center screen. The center screen will go completely to the floor.

Dimensions

Umami

Features	Overall Depth	Width	Height	Seat Depth	Seat Height from Floor	Installed Screen Height
Umami						
Platform						
Small—Single	15"	30"	16½"	N.A.	N.A.	N.A.
Small—Double	15"	60"	16½"	N.A.	N.A.	N.A.
Large—Single	30"	30"	16½"	N.A.	N.A.	N.A.
Large—Double	30"	60"	16½"	N.A.	N.A.	N.A.
Lounge						
Lounge Seating, Single	30"	30"	31"	17¼"	16½"	N.A.
Lounge Seating, Double	30"	60"	31"	17¼"	16½"	N.A.
Screen						
Standard	⅝"	15"	36½"	N.A.	N.A.	48"
	⅝"	30"	36½"	N.A.	N.A.	48"
	⅝"	15"	48½"	N.A.	N.A.	60"
	⅝"	30"	48½"	N.A.	N.A.	60"
Standard Spanner	⅝"	90"	48"	N.A.	N.A.	48"
	⅝"	105"	48"	N.A.	N.A.	48"
	⅝"	90"	60"	N.A.	N.A.	60"
	⅝"	105"	60"	N.A.	N.A.	60"

Umami

Single Platform

SIN 711.16

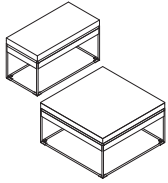

	Standard Includes	Required to Specify
▶ Need help? Product details, page 276	<ul style="list-style-type: none"> • Top: fabric price group 1 or laminate price group 1 • Fascia: monolithic, matches top • Frame: paint price group 1 • Glides • Ships fully assembled • Attachment package 	<ol style="list-style-type: none"> 1 Style number 2 Fabric or laminate color number for top 3 Paint color number for frame 4 Platform size (see below under Required Selections) 5 Material scheme (see below under Required Selections) 6 Options, if selected (see below) <p>▶ See <i>Surface Materials</i>, page 432</p>

	Required Selections	Price	Required to Specify
Platform Size	<ul style="list-style-type: none"> • 15"D x 30"W • 30"D x 30"W 	<p>Prices at right</p> <p>Prices at right</p>	<p>Specify <i>with 15"D</i>.</p> <p>Specify <i>with 30"D</i>.</p>
Material Scheme	<ul style="list-style-type: none"> • Monolithic • Contrasting fascia • Contrasting front • Contrasting back • Contrasting left • Contrasting right • Contrasting front and back • Contrasting left and right 	<p>No cost</p> <p>No cost</p> <p>No cost</p> <p>No cost</p> <p>No cost</p> <p>No cost</p> <p>No cost</p> <p>No cost</p>	<p>Specify <i>with monolithic</i>.</p> <p>Specify <i>with contrasting fascia</i>.</p> <p>Specify <i>with contrasting front</i>.</p> <p>Specify <i>with contrasting back</i>.</p> <p>Specify <i>with contrasting left</i>.</p> <p>Specify <i>with contrasting right</i>.</p> <p>Specify <i>with contrasting front and back</i>.</p> <p>Specify <i>with contrasting left and right</i>.</p>

	Options	Price	Required to Specify
Surface Materials	<p>Top finish for 15"D x 30"W</p> <ul style="list-style-type: none"> • Fabric price group 1 • Fabric price group 2 • Fabric price group 3 • Fabric price group 4 • Fabric price group 5 • Fabric price group 6 • Fabric price group 7 • Fabric price group 8 • Fabric price group 9 • Fabric price group 10 • Elmosoft leather upholstery • Steelcase vinyl • Customer's Own Material (COM) • Laminate price group 1 • Laminate price group 2 • Open Line laminate (OLL) • Wood group 1 • Wood group 2 • Wood group 3 • Customiz stain 	<p>No cost</p> <p>+\$ 19</p> <p>+\$ 28</p> <p>+\$ 39</p> <p>+\$ 49</p> <p>+\$ 60</p> <p>+\$ 69</p> <p>+\$ 88</p> <p>+\$108</p> <p>+\$122</p> <p>+\$258</p> <p>+\$ 18</p> <p>No cost</p> <p>No cost</p> <p>+\$ 5</p> <p>+\$ 69</p> <p>+\$312</p> <p>+\$355</p> <p>+\$456</p> <p>+\$312</p>	<p>Specify fabric color number.</p> <p>Specify fabric color number.</p> <p>Specify fabric color number.</p> <p>Specify fabric color number.</p> <p>Specify fabric color number.</p> <p>Specify fabric color number.</p> <p>Specify fabric color number.</p> <p>Specify fabric color number.</p> <p>Specify fabric color number.</p> <p>Specify fabric color number.</p> <p>Specify Elmosoft leather color number.</p> <p>Specify vinyl color number.</p> <p>▶ See <i>Surface Materials Reference Manual</i>.</p> <p>Specify laminate color number.</p> <p>Specify laminate color number.</p> <p>▶ See <i>Surface Materials Reference Manual</i>.</p> <p>Specify wood color number.</p> <p>Specify wood color number.</p> <p>Specify wood color number.</p> <p>Specify <i>with Customiz stain</i>.</p>

▶ Options, continued on next page

SIN 711.16

► Options, continued from previous page

Options	Price	Required to Specify
Surface Materials, continued	Top finish for 30"D x 30"W	
• Fabric price group 1	No cost	Specify fabric color number.
• Fabric price group 2	+\$ 25	Specify fabric color number.
• Fabric price group 3	+\$ 47	Specify fabric color number.
• Fabric price group 4	+\$ 66	Specify fabric color number.
• Fabric price group 5	+\$ 83	Specify fabric color number.
• Fabric price group 6	+\$102	Specify fabric color number.
• Fabric price group 7	+\$118	Specify fabric color number.
• Fabric price group 8	+\$149	Specify fabric color number.
• Fabric price group 9	+\$183	Specify fabric color number.
• Fabric price group 10	+\$208	Specify fabric color number.
• Elmosoft leather upholstery	+\$438	Specify Elmosoft leather color number.
• Steelcase vinyl	+\$ 25	Specify vinyl color number.
• Customer's Own Material (COM)	No cost	► See <i>Surface Materials Reference Manual</i> .
• Laminate price group 1	No cost	Specify laminate color number.
• Laminate price group 2	+\$ 9	Specify laminate color number.
• Open Line laminate (OLL)	+\$ 69	► See <i>Surface Materials Reference Manual</i> .
• Wood group 1	+\$534	Specify wood color number.
• Wood group 2	+\$603	Specify wood color number.
• Wood group 3	+\$776	Specify wood color number.
• Customiz stain	+\$534	Specify with <i>Customiz stain</i> .
	Frame finish	
• Paint price group 1	No cost	Specify paint color number.
• Paint price group 2	+\$ 50	Specify paint color number.
• Paint price group 3	+\$107	Specify paint color number.
Contrasting Material Scheme	Contrasting fascia finish, if contrasting fascia selected on platforms with upholstered tops	
• Fabric price group 1	No cost	Specify fabric color number.
• Fabric price group 2	+\$ 19	Specify fabric color number.
• Fabric price group 3	+\$ 28	Specify fabric color number.
• Fabric price group 4	+\$ 39	Specify fabric color number.
• Fabric price group 5	+\$ 49	Specify fabric color number.
• Fabric price group 6	+\$ 60	Specify fabric color number.
• Fabric price group 7	+\$ 69	Specify fabric color number.
• Fabric price group 8	+\$ 88	Specify fabric color number.
• Fabric price group 9	+\$108	Specify fabric color number.
• Fabric price group 10	+\$122	Specify fabric color number.
• Elmosoft leather upholstery	+\$258	Specify Elmosoft leather color number.
• Steelcase vinyl	+\$ 18	Specify vinyl color number.
• Customer's Own Material (COM)	No cost	► See <i>Surface Materials Reference Manual</i> .
	Contrasting fascia finish, if contrasting fascia selected on platforms with laminate or veneer tops	
• Laminate group 1 and 2	No cost	Specify laminate color number.
• Open Line laminate (OLL)	+\$ 69	► See <i>Surface Materials Reference Manual</i> .
• Wood group 1	+\$312	Specify wood color number
• Wood group 2	+\$355	Specify wood color number.
• Wood group 3	+\$456	Specify wood color number.
• Customiz stain	+\$312	Specify with <i>Customiz stain</i> .
	Contrasting sides, if contrasting side selected	
• Fabric price group 1	No cost	Specify fabric color number.
• Fabric price group 2	+\$ 10	Specify fabric color number.
• Fabric price group 3	+\$ 15	Specify fabric color number.
• Fabric price group 4	+\$ 20	Specify fabric color number.
• Fabric price group 5	+\$ 25	Specify fabric color number.
• Fabric price group 6	+\$ 29	Specify fabric color number.
• Fabric price group 7	+\$ 33	Specify fabric color number.
• Fabric price group 8	+\$ 38	Specify fabric color number.
• Fabric price group 9	+\$ 48	Specify fabric color number.
• Fabric price group 10	+\$ 55	Specify fabric color number.

Tip: Contrasting sides are only allowed on fabric platforms.

Tip: Contrasting sides include the following material schemes—contrasting front, contrasting back, contrasting left, contrasting right, contrasting front and back, and contrasting left and right.

► Options, continued on next page

Umami, Single Platform, continued

SIN 711.16

► Options, continued from previous page

Options	Price	Required to Specify
Contrasting Material Scheme, continued	Contrasting sides, if contrasting side selected, continued	
• Elmosoft leather upholstery	+\$119	Specify Elmosoft leather color number.
• Steelcase vinyl	+\$ 8	Specify vinyl color number.
• Customer's Own Material (COM)	No cost	► See <i>Surface Materials Reference Manual</i> .
Tables (on platform with upholstered top)	Table type (on 30"D x 30"W platform only)	
• No table	No cost	Specify <i>with no table</i> .
• Round table	+\$350	Specify <i>with round table</i> and select color number.
• Pill table	+\$350	Specify <i>with pill table</i> and select color number.
	Table location	
	• Table left	No cost Specify <i>with table left</i> .
	• Table right	No cost Specify <i>with table right</i> .
	Table support finish	
	• Paint group 1	No cost Specify paint color number.
	• Paint group 2	+\$ 15 Specify paint color number.
	• Paint group 3	+\$ 27 Specify paint color number.
Power Configuration	Power type	
	• No power	No cost Specify <i>with no power</i> .
	• Power block	+\$330 Specify <i>with power block</i> .
	Power configuration for power block	
	• Three power	No cost Specify <i>with 3 power</i> .
	• Two power, one USB	+\$117 Specify <i>with 2 power, 1 USB</i> .
	Power plug type	
	• Standard NEMA 5–15 3 prong	No cost Specify <i>with NEMA</i> .
	• Low profile plug	+\$ 26 Specify <i>with low profile plug</i> .
	Tamper resistant	
	• No tamper resistant	No cost Specify <i>with no tamper resistant</i> .
	• Tamper resistant	+\$ 20 Specify <i>with tamper resistant</i> .

Tip: Platform table power is located at the center back of platform top.

Tip: Power is provided by a 72" power cord.

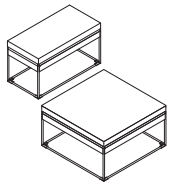

Specification Information				
Dimensions W H		Style Number	Base Prices	
			15"D	30"D
30"	16½"	STLPLTF1	\$1050	\$1365

Umami

Double Platform

SIN 711.16

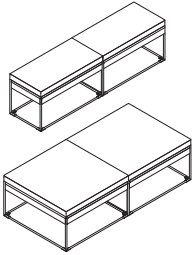

Tip: On 15"D platforms, the front is the 60"W side. When selecting contrasting left or right, the 15"D sides are the contrasting sides.

Tip: Only a single material scheme can be selected. For example, both contrasting fascia and contrasting front cannot be selected together. If more than one material scheme is desired, contact a specials representative.

Standard Includes		Required to Specify
<ul style="list-style-type: none"> ▶ Need help? Product details, page 276 	<ul style="list-style-type: none"> • Top: fabric price group 1 • Fascia: monolithic, matches top • Frame: paint price group 1 • Glides • Ships fully assembled • Attachment package 	<ol style="list-style-type: none"> 1 Style number 2 Fabric color number for top 3 Paint color number for frame 4 Platform size (see below under Required Selections) 5 Material scheme (see below under Required Selections) 6 Options, if selected (see below) <p>▶ See <i>Surface Materials</i>, page 432</p>

	Required Selections	Price	Required to Specify
Platform Size	<ul style="list-style-type: none"> • 15"D x 60"W • 30"D x 60"W 	<p>Prices at right</p> <p>Prices at right</p>	<p>Specify with 15"D.</p> <p>Specify with 30"D.</p>
Material Scheme	<ul style="list-style-type: none"> • Monolithic • Contrasting fascia • Contrasting front • Contrasting back • Contrasting left • Contrasting right • Contrasting front and back • Contrasting left and right • Contrasting seam • Contrasting seam, left and right 	<p>No cost</p> <p>No cost</p> <p>No cost</p> <p>No cost</p> <p>No cost</p> <p>No cost</p> <p>No cost</p> <p>No cost</p> <p>No cost</p> <p>No cost</p> <p>No cost</p>	<p>Specify with <i>monolithic</i>.</p> <p>Specify with <i>contrasting fascia</i>.</p> <p>Specify with <i>contrasting front</i>.</p> <p>Specify with <i>contrasting back</i>.</p> <p>Specify with <i>contrasting left</i>.</p> <p>Specify with <i>contrasting right</i>.</p> <p>Specify with <i>contrasting front and back</i>.</p> <p>Specify with <i>contrasting left and right</i>.</p> <p>Specify with <i>contrasting seam</i>.</p> <p>Specify with <i>contrasting seam, left and right</i>.</p>

	Options	Price	Required to Specify
Surface Materials	<p>Top finish for 15"D x 60"W</p> <ul style="list-style-type: none"> • Fabric price group 1 • Fabric price group 2 • Fabric price group 3 • Fabric price group 4 • Fabric price group 5 • Fabric price group 6 • Fabric price group 7 • Fabric price group 8 • Fabric price group 9 • Fabric price group 10 • Elmosoft leather upholstery • Steelcase vinyl • Customer's Own Material (COM) <p>Top finish for 30"D x 60"W</p> <ul style="list-style-type: none"> • Fabric price group 1 • Fabric price group 2 • Fabric price group 3 • Fabric price group 4 • Fabric price group 5 • Fabric price group 6 • Fabric price group 7 • Fabric price group 8 • Fabric price group 9 • Fabric price group 10 • Elmosoft leather upholstery • Steelcase vinyl • Customer's Own Material (COM) 	<p>No cost</p> <p>+\$ 34</p> <p>+\$ 50</p> <p>+\$ 70</p> <p>+\$ 88</p> <p>+\$108</p> <p>+\$124</p> <p>+\$158</p> <p>+\$194</p> <p>+\$220</p> <p>+\$464</p> <p>+\$ 32</p> <p>No cost</p> <p>No cost</p> <p>+\$ 48</p> <p>+\$ 89</p> <p>+\$125</p> <p>+\$158</p> <p>+\$194</p> <p>+\$224</p> <p>+\$283</p> <p>+\$348</p> <p>+\$395</p> <p>+\$831</p> <p>+\$ 45</p> <p>No cost</p>	<p>Specify fabric color number.</p> <p>Specify fabric color number.</p> <p>Specify fabric color number.</p> <p>Specify fabric color number.</p> <p>Specify fabric color number.</p> <p>Specify fabric color number.</p> <p>Specify fabric color number.</p> <p>Specify fabric color number.</p> <p>Specify fabric color number.</p> <p>Specify fabric color number.</p> <p>Specify Elmosoft leather color number.</p> <p>Specify vinyl color number.</p> <p>▶ See <i>Surface Materials Reference Manual</i>.</p> <p>Specify fabric color number.</p> <p>Specify fabric color number.</p> <p>Specify fabric color number.</p> <p>Specify fabric color number.</p> <p>Specify fabric color number.</p> <p>Specify fabric color number.</p> <p>Specify fabric color number.</p> <p>Specify fabric color number.</p> <p>Specify fabric color number.</p> <p>Specify Elmosoft leather color number.</p> <p>Specify vinyl color number.</p> <p>▶ See <i>Surface Materials Reference Manual</i>.</p>

▶ Options, continued on next page

SIN 711.16

► Options, continued from previous page

Options	Price	Required to Specify
Surface Materials, continued	Frame finish	
	• Paint price group 1	No cost
	• Paint price group 2	+\$ 85
	• Paint price group 3	+\$182
Contrasting Material Scheme	Contrasting fascia finish, if contrasting fascia selected	
	• Fabric price group 1	No cost
	• Fabric price group 2	+\$ 30
	• Fabric price group 3	+\$ 45
	• Fabric price group 4	+\$ 62
	• Fabric price group 5	+\$ 78
	• Fabric price group 6	+\$ 96
	• Fabric price group 7	+\$110
	• Fabric price group 8	+\$141
	• Fabric price group 9	+\$173
	• Fabric price group 10	+\$195
	• Elmosoft leather upholstery	+\$412
	• Steelcase vinyl	+\$ 29
	• Customer's Own Material (COM)	No cost
		Specify fabric color number.
		Specify fabric color number.
		Specify fabric color number.
		Specify fabric color number.
		Specify fabric color number.
		Specify fabric color number.
		Specify fabric color number.
		Specify Elmosoft leather color number.
		Specify vinyl color number.
		► See <i>Surface Materials Reference Manual</i> .
	Contrasting sides finish, if contrasting side selected	
	• Fabric price group 1	No cost
	• Fabric price group 2	+\$ 19
	• Fabric price group 3	+\$ 28
	• Fabric price group 4	+\$ 39
	• Fabric price group 5	+\$ 49
	• Fabric price group 6	+\$ 60
	• Fabric price group 7	+\$ 69
	• Fabric price group 8	+\$ 88
	• Fabric price group 9	+\$108
	• Fabric price group 10	+\$122
	• Elmosoft leather upholstery	+\$258
	• Steelcase vinyl	+\$ 18
	• Customer's Own Material (COM)	No cost
		Specify fabric color number.
		Specify fabric color number.
		Specify fabric color number.
		Specify fabric color number.
		Specify fabric color number.
		Specify fabric color number.
		Specify fabric color number.
		Specify Elmosoft leather color number.
		Specify color number.
		► See <i>Surface Materials Reference Manual</i> .
Tables	Table type (on 30"D x 60"W platform only)	
	• No table	No cost
	• Round table	+\$350
		Specify <i>with no table</i> .
		Specify <i>with round table</i> and select color number.
	• Pill table	+\$350
		Specify <i>with pill table</i> and select color number.
	Table location	
	• Table left	No cost
	• Table right	No cost
		Specify <i>with table left</i> .
		Specify <i>with table right</i> .
	Table support finish	
	• Paint group 1	No cost
	• Paint group 2	+\$ 15
	• Paint group 3	+\$ 27
		Specify paint color number.
		Specify paint color number.
		Specify paint color number.

► Options, continued on next page

Tip: Contrasting sides are only allowed on fabric platforms.

Tip: Contrasting sides include the following material schemes—contrasting front, contrasting back, contrasting left, contrasting right, contrasting front and back, and contrasting left and right.

Umami, Double Platform, continued

SIN 711.16

► Options, continued from previous page

Tip: Power is provided by a 72" power cord.

Options	Price	Required to Specify
Power Configuration	Power type	
	• No power	No cost
	• Power block	+\$330
	• Two power blocks	+\$660
	Outlet configuration	
	• Three power	No cost
	• Two power, one USB	+\$117
	Power plug type	
	• Standard NEMA 5-15 3 prong	No cost
	• Low profile plug	+\$ 26
	Tamper resistant	
	• No tamper resistant	No cost
	• Tamper resistant	+\$ 20

Specification Information

Dimensions W H	Style Number	Base Prices	
		15"D	30"D
60" 16 1/2"	STLPLTF2	\$1540	\$2002

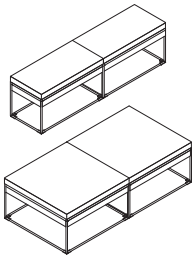

Umami Straight Lounge

Single

SIN 711.16

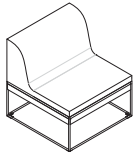

Tip: Only a single material scheme can be selected. For example, both contrasting fascia and contrasting front cannot be selected together. If more than one material scheme is desired, contact a specials representative.

Standard Includes		Required to Specify
<ul style="list-style-type: none"> ▶ Need help? Product details, page 276 	<ul style="list-style-type: none"> • Seat upholstery: fabric price group 1 • Fascia: monolithic, matches top • Frame: paint price group 1 • Ships fully assembled • Attachment package 	<ol style="list-style-type: none"> 1 Style number 2 Fabric color number for seat 3 Paint color number for frame 4 Material scheme (see below under Required Selections) 5 Options, if selected (see below) <ul style="list-style-type: none"> ▶ See <i>Surface Materials</i>, page 432

Material Scheme	Required Selections	Price	Required to Specify
Material Scheme	• Monolithic	No cost	Specify <i>with monolithic</i> .
	• Contrasting fascia	No cost	Specify <i>with contrasting fascia</i> .
	• Contrasting front	No cost	Specify <i>with contrasting front</i> .
	• Contrasting back	No cost	Specify <i>with contrasting back</i> .
	• Contrasting left	No cost	Specify <i>with contrasting left</i> .
	• Contrasting right	No cost	Specify <i>with contrasting right</i> .
	• Contrasting front and back	No cost	Specify <i>with contrasting front and back</i> .
	• Contrasting left and right	No cost	Specify <i>with contrasting left and right</i> .

Surface Materials	Options	Price	Required to Specify
Surface Materials	Seat finish		
	• Fabric price group 1	No cost	Specify fabric color number.
	• Fabric price group 2	+\$ 48	Specify fabric color number.
	• Fabric price group 3	+\$ 89	Specify fabric color number.
	• Fabric price group 4	+\$125	Specify fabric color number.
	• Fabric price group 5	+\$158	Specify fabric color number.
	• Fabric price group 6	+\$194	Specify fabric color number.
	• Fabric price group 7	+\$224	Specify fabric color number.
	• Fabric price group 8	+\$283	Specify fabric color number.
	• Fabric price group 9	+\$348	Specify fabric color number.
	• Fabric price group 10	+\$395	Specify fabric color number.
	• Elmosoft leather upholstery	+\$831	Specify Elmosoft leather color number.
	• Steelcase vinyl	+\$ 48	Specify vinyl color number.
	• Customer's Own Material (COM)	No cost	▶ See <i>Surface Materials Reference Manual</i> .
		Soil-retardant treatment	+\$ 25
	Frame finish		
	• Paint price group 1	No cost	Specify paint color number.
	• Paint price group 2	+\$ 50	Specify paint color number.
	• Paint price group 3	+\$107	Specify paint color number.

Contrasting Material Scheme	Contrasting fascia finish, if contrasting fascia selected	Price	Required to Specify
Contrasting Material Scheme	• Fabric price group 1	No cost	Specify fabric color number.
	• Fabric price group 2	+\$ 19	Specify fabric color number.
	• Fabric price group 3	+\$ 28	Specify fabric color number.
	• Fabric price group 4	+\$ 39	Specify fabric color number.
	• Fabric price group 5	+\$ 49	Specify fabric color number.
	• Fabric price group 6	+\$ 60	Specify fabric color number.
	• Fabric price group 7	+\$ 69	Specify fabric color number.
	• Fabric price group 8	+\$ 88	Specify fabric color number.
	• Fabric price group 9	+\$108	Specify fabric color number.
	• Fabric price group 10	+\$122	Specify fabric color number.
	• Elmosoft leather upholstery	+\$258	Specify Elmosoft leather color number.
	• Steelcase vinyl	+\$ 18	Specify vinyl color number.
	• Customer's Own Material (COM)	No cost	▶ See <i>Surface Materials Reference Manual</i> .

▶ Options, continued on next page

SIN 711.16

► Options, continued from previous page

Options	Price	Required to Specify
Contrasting Material Scheme, continued	Contrasting sides finish, if contrasting side selected	
• Fabric price group 1	No cost	Specify fabric color number.
• Fabric price group 2	+\$ 19	Specify fabric color number.
• Fabric price group 3	+\$ 28	Specify fabric color number.
• Fabric price group 4	+\$ 39	Specify fabric color number.
• Fabric price group 5	+\$ 49	Specify fabric color number.
• Fabric price group 6	+\$ 60	Specify fabric color number.
• Fabric price group 7	+\$ 69	Specify fabric color number.
• Fabric price group 8	+\$ 88	Specify fabric color number.
• Fabric price group 9	+\$108	Specify fabric color number.
• Fabric price group 10	+\$122	Specify fabric color number.
• Elmosoft leather upholstery	+\$258	Specify Elmosoft leather color number.
• Steelcase vinyl	+\$ 18	Specify vinyl color number.
• Customer's Own Material (COM)	No cost	► See <i>Surface Materials Reference Manual</i> .
Tables	Table type	
	• No table	No cost Specify <i>with no table</i> .
	• Round table	+\$350 Specify <i>with round table</i> and select color number.
	• Pill table	+\$350 Specify <i>with pill table</i> and select color number.
	Table location	
	• Table left	No cost Specify <i>with table left</i> .
	• Table right	No cost Specify <i>with table right</i> .
	Table support finish	
	• Paint price group 1	No cost Specify paint color number.
	• Paint price group 2	+\$ 15 Specify paint color number.
	• Paint price group 3	+\$ 27 Specify paint color number.
Power Configuration	Power type	
	• No power	No cost Specify <i>with no power</i> .
	• Power block	+\$330 Specify <i>with power block</i> .
	Outlet configuration	
	• Three power	No cost Specify <i>with 3 power</i> .
	• Two power, one USB	+\$117 Specify <i>with 2 power, 1 USB</i> .
	Power plug type	
	• Standard NEMA 5–15 3 prong	No cost Specify <i>with NEMA</i> .
	• Low profile plug	+\$ 26 Specify <i>with low profile plug</i> .
	Tamper resistant	
	• No tamper resistant	No cost Specify <i>with no tamper resistant</i> .
	• Tamper resistant	+\$ 20 Specify <i>with tamper resistant</i> .

Tip: Platform table power is located at the center back of platform top.

Tip: Power is provided by a 72" power cord.

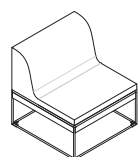

Specification Information

Dimensions			Style	Base
D	W	H	Number	Price
30"	30"	31"	STLLNGST1	\$1971

Umami Straight Lounge

Double

SIN 711.16

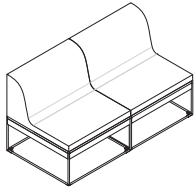

Tip: Only a single material scheme can be selected. For example, both contrasting fascia and contrasting front cannot be selected together. If more than one material scheme is desired, contact a specials representative.

Standard Includes		Required to Specify
<ul style="list-style-type: none"> ▶ Need help? Product details, page 276 	<ul style="list-style-type: none"> • Seat upholstery: fabric price group 1 • Fascia: monolithic, matches top • Frame: paint price group 1 • Ships ready to assemble • Attachment package 	<ol style="list-style-type: none"> 1 Style number 2 Fabric color number for seat 3 Paint color number for frame 4 Material scheme (see below under Required Selections) 5 Options, if selected (see below) <ul style="list-style-type: none"> ▶ See <i>Surface Materials</i>, page 432

Required Selections	Price	Required to Specify
Material Scheme <ul style="list-style-type: none"> • Monolithic • Contrasting fascia • Contrasting front • Contrasting back • Contrasting left • Contrasting right • Contrasting front and back • Contrasting left and right • Contrasting seam • Contrasting seam, left and right 	<ul style="list-style-type: none"> No cost No cost No cost No cost No cost No cost No cost No cost No cost No cost 	<ul style="list-style-type: none"> Specify <i>with monolithic</i>. Specify <i>with contrasting fascia</i>. Specify <i>with contrasting front</i>. Specify <i>with contrasting back</i>. Specify <i>with contrasting left</i>. Specify <i>with contrasting right</i>. Specify <i>with contrasting front and back</i>. Specify <i>with contrasting left and right</i>. Specify <i>with contrasting seam</i>. Specify <i>with contrasting seam, left and right</i>.

Options	Price	Required to Specify
Surface Materials		
Seat finish <ul style="list-style-type: none"> • Fabric price group 1 • Fabric price group 2 • Fabric price group 3 • Fabric price group 4 • Fabric price group 5 • Fabric price group 6 • Fabric price group 7 • Fabric price group 8 • Fabric price group 9 • Fabric price group 10 • Elmosoft leather upholstery • Steelcase vinyl • Customer's Own Material (COM) 	<ul style="list-style-type: none"> No cost +\$ 86 +\$ 160 +\$ 225 +\$ 284 +\$ 349 +\$ 403 +\$ 509 +\$ 626 +\$ 711 +\$1496 +\$ 86 No cost 	<ul style="list-style-type: none"> Specify fabric color number. Specify fabric color number. Specify fabric color number. Specify fabric color number. Specify fabric color number. Specify fabric color number. Specify fabric color number. Specify fabric color number. Specify fabric color number. Specify fabric color number. Specify Elmosoft leather color number. Specify vinyl color number. <ul style="list-style-type: none"> ▶ See <i>Surface Materials Reference Manual</i>.
Frame finish <ul style="list-style-type: none"> • Paint price group 1 • Paint price group 2 • Paint price group 3 	<ul style="list-style-type: none"> No cost +\$ 85 +\$ 182 	<ul style="list-style-type: none"> Specify paint color number. Specify paint color number. Specify paint color number.

Contrasting Material Scheme	Contrasting fascia finish, if contrasting fascia selected	Price	Required to Specify
<ul style="list-style-type: none"> • Fabric price group 1 • Fabric price group 2 • Fabric price group 3 • Fabric price group 4 • Fabric price group 5 • Fabric price group 6 • Fabric price group 7 • Fabric price group 8 • Fabric price group 9 • Fabric price group 10 • Elmosoft leather upholstery • Steelcase vinyl • Customer's Own Material (COM) 	<ul style="list-style-type: none"> • Fabric price group 1 • Fabric price group 2 • Fabric price group 3 • Fabric price group 4 • Fabric price group 5 • Fabric price group 6 • Fabric price group 7 • Fabric price group 8 • Fabric price group 9 • Fabric price group 10 • Elmosoft leather upholstery • Steelcase vinyl • Customer's Own Material (COM) 	<ul style="list-style-type: none"> No cost +\$ 30 +\$ 45 +\$ 62 +\$ 78 +\$ 96 +\$ 110 +\$ 141 +\$ 173 +\$ 195 +\$ 412 +\$ 29 No cost 	<ul style="list-style-type: none"> Specify fabric color number. Specify fabric color number. Specify fabric color number. Specify fabric color number. Specify fabric color number. Specify fabric color number. Specify fabric color number. Specify fabric color number. Specify fabric color number. Specify fabric color number. Specify Elmosoft leather color number. Specify vinyl color number. <ul style="list-style-type: none"> ▶ See <i>Surface Materials Reference Manual</i>.

▶ Options, continued on next page

SIN 711.16

► Options, continued from previous page

Options	Price	Required to Specify
Contrasting Material Scheme, continued	Contrasting sides finish, if contrasting side selected	
• Fabric price group 1	No cost	Specify fabric color number.
• Fabric price group 2	+\$ 25	Specify fabric color number.
• Fabric price group 3	+\$ 47	Specify fabric color number.
• Fabric price group 4	+\$ 66	Specify fabric color number.
• Fabric price group 5	+\$ 83	Specify fabric color number.
• Fabric price group 6	+\$102	Specify fabric color number.
• Fabric price group 7	+\$118	Specify fabric color number.
• Fabric price group 8	+\$149	Specify fabric color number.
• Fabric price group 9	+\$183	Specify fabric color number.
• Fabric price group 10	+\$208	Specify fabric color number.
• Elmosoft leather upholstery	+\$438	Specify Elmosoft leather color number.
• Steelcase vinyl	+\$ 25	Specify vinyl color number.
• Customer's Own Material (COM)	No cost	► See <i>Surface Materials Reference Manual</i> .
Tables	Table type	
	• No table	No cost Specify <i>with no table</i> .
	• Round table	+\$350 Specify <i>with round table</i> and select color number.
	• Pill table	+\$350 Specify <i>with pill table</i> and select color number.
	Table location	
	• Table left	No cost Specify <i>with table left</i> .
	• Table right	No cost Specify <i>with table right</i> .
	Table support finish	
	• Paint price group 1	No cost Specify paint color number.
	• Paint price group 2	+\$ 15 Specify paint color number.
	• Paint price group 3	+\$ 27 Specify paint color number.
Power Configuration	Power type	
	• No power	No cost Specify <i>with no power</i> .
	• Power block	+\$330 Specify <i>with power block</i> .
	• Two power blocks	+\$660 Specify <i>with two power blocks</i> .
	Outlet configuration	
	• Three power	No cost Specify <i>with 3 power</i> .
	• Two power, one USB	+\$117 Specify <i>with 2 power, 1 USB</i> .
	Power plug type	
	• Standard NEMA 5–15 3 prong	No cost Specify <i>with NEMA</i> .
	• Low profile plug	+\$ 26 Specify <i>with low profile plug</i> .
	Tamper resistant	
	• No tamper resistant	No cost Specify <i>with no tamper resistant</i> .
	• Tamper resistant	+\$ 20 Specify <i>with tamper resistant</i> .

Tip: Power is provided by a 72" power cord.

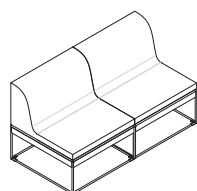

Specification Information

Dimensions			Style Number	Base Price
D	W	H		
30"	60"	31"	STLLNGST2	\$2850

Umami Lounge

One Arm, Single

SIN 711.16

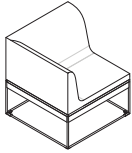

Tip: Only a single material scheme can be selected. For example, both contrasting fascia and contrasting front cannot be selected together. If more than one material scheme is desired, contact a specials representative.

Standard Includes	Required to Specify
<ul style="list-style-type: none"> ▶ Need help? Product details, page 276 • Seat upholstery: fabric price group 1 • Fascia: monolithic, matches top • Frame: paint price group 1 • Ships fully assembled • Attachment package 	<ol style="list-style-type: none"> 1 Style number 2 Fabric color number for seat 3 Paint color number for frame 4 Material scheme (see below under Required Selections) 5 Arm position (see below under Required Selections) 6 Options, if selected (see below) <ul style="list-style-type: none"> ▶ See <i>Surface Materials</i>, page 432.

	Required Selections	Price	Required to Specify
Material Scheme	<ul style="list-style-type: none"> • Monolithic • Contrasting fascia • Contrasting front • Contrasting back • Contrasting left • Contrasting right • Contrasting front and back • Contrasting left and right 	<ul style="list-style-type: none"> No cost No cost No cost No cost No cost No cost No cost No cost 	<ul style="list-style-type: none"> Specify <i>with monolithic</i>. Specify <i>with contrasting fascia</i>. Specify <i>with contrasting front</i>. Specify <i>with contrasting back</i>. Specify <i>with contrasting left</i>. Specify <i>with contrasting right</i>. Specify <i>with contrasting front and back</i>. Specify <i>with contrasting left and right</i>.
Arm Position	<ul style="list-style-type: none"> • Left arm • Right arm 	<ul style="list-style-type: none"> No cost No cost 	<ul style="list-style-type: none"> Specify <i>with left arm</i>. Specify <i>with right arm</i>.

	Options	Price	Required to Specify
Surface Materials	<p>Seat finish</p> <ul style="list-style-type: none"> • Fabric price group 1 • Fabric price group 2 • Fabric price group 3 • Fabric price group 4 • Fabric price group 5 • Fabric price group 6 • Fabric price group 7 • Fabric price group 8 • Fabric price group 9 • Fabric price group 10 • Elmosoft leather upholstery • Steelcase vinyl • Customer's Own Material (COM) <p>Frame finish</p> <ul style="list-style-type: none"> • Paint price group 1 • Paint price group 2 • Paint price group 3 	<ul style="list-style-type: none"> No cost +\$ 53 +\$ 98 +\$138 +\$174 +\$213 +\$246 +\$311 +\$383 +\$435 +\$831 +\$ 53 No cost No cost +\$ 50 +\$107 	<ul style="list-style-type: none"> Specify fabric color number. Specify fabric color number. Specify fabric color number. Specify fabric color number. Specify fabric color number. Specify fabric color number. Specify fabric color number. Specify fabric color number. Specify fabric color number. Specify fabric color number. Specify Elmosoft leather color number. Specify vinyl color number. ▶ See <i>Surface Materials Reference Manual</i>. Specify paint color number. Specify paint color number. Specify paint color number.

▶ Options, continued on next page

► Options, continued from previous page

Options	Price	Required to Specify
Contrasting Material Scheme		
Contrasting fascia finish, if contrasting fascia selected		
• Fabric price group 1	No cost	Specify fabric color number.
• Fabric price group 2	+\$ 19	Specify fabric color number.
• Fabric price group 3	+\$ 28	Specify fabric color number.
• Fabric price group 4	+\$ 39	Specify fabric color number.
• Fabric price group 5	+\$ 49	Specify fabric color number.
• Fabric price group 6	+\$ 60	Specify fabric color number.
• Fabric price group 7	+\$ 69	Specify fabric color number.
• Fabric price group 8	+\$ 88	Specify fabric color number.
• Fabric price group 9	+\$108	Specify fabric color number.
• Fabric price group 10	+\$122	Specify fabric color number.
• Elmosoft leather upholstery	+\$258	Specify Elmosoft leather color number.
• Steelcase vinyl	+\$ 18	Specify vinyl color number.
• Customer's Own Material (COM)	No cost	► See <i>Surface Materials Reference Manual</i> .
Contrasting sides finish, if contrasting side selected		
• Fabric price group 1	No cost	Specify fabric color number.
• Fabric price group 2	+\$ 19	Specify fabric color number.
• Fabric price group 3	+\$ 28	Specify fabric color number.
• Fabric price group 4	+\$ 39	Specify fabric color number.
• Fabric price group 5	+\$ 49	Specify fabric color number.
• Fabric price group 6	+\$ 60	Specify fabric color number.
• Fabric price group 7	+\$ 69	Specify fabric color number.
• Fabric price group 8	+\$ 88	Specify fabric color number.
• Fabric price group 9	+\$108	Specify fabric color number.
• Fabric price group 10	+\$122	Specify fabric color number.
• Elmosoft leather upholstery	+\$258	Specify Elmosoft leather color number.
• Steelcase vinyl	+\$ 18	Specify vinyl color number.
• Customer's Own Material (COM)	No cost	► See <i>Surface Materials Reference Manual</i> .
Power Configuration		
Power type		
• No power	No cost	Specify with no power.
• Power block	+\$330	Specify with power block.
Outlet configuration		
• Three power	No cost	Specify with 3 power.
• Two power, one USB	+\$117	Specify with 2 power, 1 USB.
Power plug type		
• Standard NEMA 5–15 3 prong	No cost	Specify with NEMA.
• Low profile plug	+\$ 26	Specify with low profile plug.
Tamper resistant		
• No tamper resistant	No cost	Specify with no tamper resistant.
• Tamper resistant	+\$ 20	Specify with tamper resistant.

Tip: Power is provided by a 72" power cord.



Specification Information				
Dimensions			Style	Base
D	W	H	Number	Price
30"	30"	31"	STLLNGAR1	\$2565

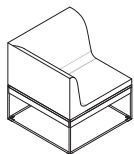

Umami Lounge

One Arm, Double

SIN 711.16

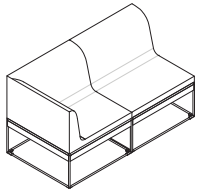

Standard Includes		Required to Specify
<ul style="list-style-type: none"> ▶ Need help? Product details, page 276 	<ul style="list-style-type: none"> • Seat upholstery: fabric price group 1 • Fascia: monolithic, matches top • Frame: paint price group 1 • Ships ready to assemble • Attachment package 	<ol style="list-style-type: none"> 1 Style number 2 Fabric color number for seat 3 Paint color number for frame 4 Material scheme (see below under Required Selections) 5 Arm position (see below under Required Selections) 6 Options, if selected (see below) <ul style="list-style-type: none"> ▶ See <i>Surface Materials</i>, page 432

Tip: Only a single material scheme can be selected. For example, both contrasting fascia and contrasting front cannot be selected together. If more than one material scheme is desired, contact a specials representative.

Required Selections	Price	Required to Specify
Material Scheme <ul style="list-style-type: none"> • Monolithic • Contrasting fascia • Contrasting front • Contrasting back • Contrasting left • Contrasting right • Contrasting front and back • Contrasting left and right • Contrasting seam • Contrasting seam, left and right 	<ul style="list-style-type: none"> No cost No cost No cost No cost No cost No cost No cost No cost No cost No cost 	<ul style="list-style-type: none"> Specify <i>with monolithic</i>. Specify <i>with contrasting fascia</i>. Specify <i>with contrasting front</i>. Specify <i>with contrasting back</i>. Specify <i>with contrasting left</i>. Specify <i>with contrasting right</i>. Specify <i>with contrasting front and back</i>. Specify <i>with contrasting left and right</i>. Specify <i>with contrasting seam</i>. Specify <i>with contrasting seam, left and right</i>.
Arm Position <ul style="list-style-type: none"> • Left arm • Right arm 	<ul style="list-style-type: none"> No cost No cost 	<ul style="list-style-type: none"> Specify <i>with left arm</i>. Specify <i>with right arm</i>.

Tip: Arm positions are determined based on user sitting in seat. For example, specify right arm if you want an arm on your right side while sitting.

Options	Price	Required to Specify
Surface Materials <ul style="list-style-type: none"> • Seat finish • Fabric price group 1 • Fabric price group 2 • Fabric price group 3 • Fabric price group 4 • Fabric price group 5 • Fabric price group 6 • Fabric price group 7 • Fabric price group 8 • Fabric price group 9 • Fabric price group 10 • Elmosoft leather upholstery • Steelcase vinyl • Customer's Own Material (COM) • Frame finish • Paint price group 1 • Paint price group 2 • Paint price group 3 	<ul style="list-style-type: none"> No cost +\$ 95 +\$ 176 +\$ 248 +\$ 313 +\$ 384 +\$ 444 +\$ 560 +\$ 689 +\$ 782 +\$1496 +\$ 95 No cost No cost +\$ 85 +\$ 182 	<ul style="list-style-type: none"> Specify fabric color number. Specify fabric color number. Specify fabric color number. Specify fabric color number. Specify fabric color number. Specify fabric color number. Specify fabric color number. Specify fabric color number. Specify fabric color number. Specify fabric color number. Specify Elmosoft leather color number. Specify vinyl color number. ▶ See <i>Surface Materials Reference Manual</i>. Specify paint color number. Specify paint color number. Specify paint color number.

Contrasting Material Scheme <ul style="list-style-type: none"> • Contrasting fascia finish, if contrasting fascia selected • Fabric price group 1 • Fabric price group 2 • Fabric price group 3 • Fabric price group 4 • Fabric price group 5 • Fabric price group 6 • Fabric price group 7 • Fabric price group 8 • Fabric price group 9 • Fabric price group 10 • Elmosoft leather upholstery • Steelcase vinyl • Customer's Own Material (COM) 	<ul style="list-style-type: none"> No cost +\$ 30 +\$ 45 +\$ 62 +\$ 78 +\$ 96 +\$ 110 +\$ 141 +\$ 173 +\$ 195 +\$ 412 +\$ 29 No cost 	<ul style="list-style-type: none"> Specify fabric color number. Specify fabric color number. Specify fabric color number. Specify fabric color number. Specify fabric color number. Specify fabric color number. Specify fabric color number. Specify fabric color number. Specify fabric color number. Specify fabric color number. Specify Elmosoft leather color number. Specify vinyl color number. ▶ See <i>Surface Materials Reference Manual</i>.
---	---	---

▶ Options, continued on next page

► Options, continued from previous page

Options	Price	Required to Specify
Contrasting Material Scheme, continued	Contrasting sides finish, if contrasting side selected	
• Fabric price group 1	No cost	Specify fabric color number.
• Fabric price group 2	+\$ 25	Specify fabric color number.
• Fabric price group 3	+\$ 47	Specify fabric color number.
• Fabric price group 4	+\$ 66	Specify fabric color number.
• Fabric price group 5	+\$ 83	Specify fabric color number.
• Fabric price group 6	+\$102	Specify fabric color number.
• Fabric price group 7	+\$118	Specify fabric color number.
• Fabric price group 8	+\$149	Specify fabric color number.
• Fabric price group 9	+\$183	Specify fabric color number.
• Fabric price group 10	+\$208	Specify fabric color number.
• Elmosoft leather upholstery	+\$438	Specify Elmosoft leather color number.
• Steelcase vinyl	+\$ 25	Specify vinyl color number.
• Customer's Own Material (COM)	No cost	► See <i>Surface Materials Reference Manual</i> .
Tables	Table type	
	• No table	No cost Specify <i>with no table</i> .
	• Round table	+\$350 Specify <i>with round table</i> and select color number.
	• Pill table	+\$350 Specify <i>with pill table</i> and select color number.
	Table location	
	• Table left	No cost Specify <i>with table left</i> .
	• Table right	No cost Specify <i>with table right</i> .
	Table support finish	
	• Paint group 1	No cost Specify paint color number.
	• Paint group 2	+\$ 15 Specify paint color number.
	• Paint group 3	+\$ 27 Specify paint color number.
Power Configuration	Power type	
	• No power	No cost Specify <i>with no power</i> .
	• Power block	+\$330 Specify <i>with power block</i> .
	• Two power blocks	+\$660 Specify <i>with power blocks</i> .
	Outlet configuration	
	• Three power	No cost Specify <i>with 3 power</i> .
	• Two power, one USB	+\$117 Specify <i>with 2 power, 1 USB</i> .
	Power plug type	
	• Standard NEMA 5–15 3 prong	No cost Specify <i>with NEMA</i> .
	• Low profile plug	+\$ 26 Specify <i>with low profile plug</i> .
	Tamper resistant	
	• No tamper resistant	No cost Specify <i>with no tamper resistant</i> .
	• Tamper resistant	+\$ 20 Specify <i>with tamper resistant</i> .

Tip: Power is provided by a 72" power cord.

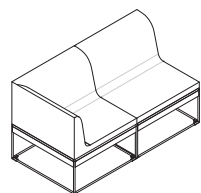

Specification Information				
Dimensions			Style Number	Base Price
D	W	H		
30"	60"	31"	STLLNGAR2	\$3444



Umami Lounge

Two Arms, Double

SIN 711.16

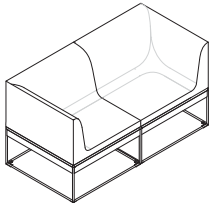

Tip: Only a single material scheme can be selected. For example, both contrasting fascia and contrasting front cannot be selected together. If more than one material scheme is desired, contact a specials representative.

Standard Includes		Required to Specify
<ul style="list-style-type: none"> ▶ Need help? Product details, page 276 	<ul style="list-style-type: none"> • Seat upholstery: fabric price group 1 • Fascia: monolithic, matches top • Frame: paint price group • Ships ready to assemble • Attachment package 	<ol style="list-style-type: none"> 1 Style number 2 Fabric color number for seat 3 Paint color number for frame 4 Material scheme (see below under Required Selections) 5 Options, if selected (see below) <ul style="list-style-type: none"> ▶ See <i>Surface Materials</i>, page 432

Required Selections	Price	Required to Specify
Material Scheme <ul style="list-style-type: none"> • Monolithic • Contrasting fascia • Contrasting front • Contrasting back • Contrasting left • Contrasting right • Contrasting front and back • Contrasting left and right • Contrasting seam • Contrasting seam, left and right 	<ul style="list-style-type: none"> No cost No cost No cost No cost No cost No cost No cost No cost No cost No cost 	<ul style="list-style-type: none"> Specify with <i>monolithic</i>. Specify with <i>contrasting fascia</i>. Specify with <i>contrasting front</i>. Specify with <i>contrasting back</i>. Specify with <i>contrasting left</i>. Specify with <i>contrasting right</i>. Specify with <i>contrasting front and back</i>. Specify with <i>contrasting left and right</i>. Specify with <i>contrasting seam</i>. Specify with <i>contrasting seam, left and right</i>.

Options	Price	Required to Specify	
Surface Materials	Seat finish <ul style="list-style-type: none"> • Fabric price group 1 • Fabric price group 2 • Fabric price group 3 • Fabric price group 4 • Fabric price group 5 • Fabric price group 6 • Fabric price group 7 • Fabric price group 8 • Fabric price group 9 • Fabric price group 10 • Elmosoft leather upholstery • Steelcase vinyl • Customer's Own Material (COM) 	<ul style="list-style-type: none"> No cost +\$ 104 +\$ 192 +\$ 270 +\$ 341 +\$ 419 +\$ 484 +\$ 611 +\$ 752 +\$ 853 +\$1496 +\$ 104 No cost 	<ul style="list-style-type: none"> Specify fabric color number. Specify fabric color number. Specify fabric color number. Specify fabric color number. Specify fabric color number. Specify fabric color number. Specify fabric color number. Specify fabric color number. Specify fabric color number. Specify fabric color number. Specify Elmosoft leather color number. Specify vinyl color number. <ul style="list-style-type: none"> ▶ See <i>Surface Materials Reference Manual</i>.
	Frame finish <ul style="list-style-type: none"> • Paint price group 1 • Paint price group 2 • Paint price group 3 	<ul style="list-style-type: none"> No cost +\$ 85 +\$ 182 	<ul style="list-style-type: none"> Specify paint color number. Specify paint color number. Specify paint color number.

▶ Options, continued on next page

► Options, continued from previous page

Options	Price	Required to Specify
Contrasting Material Scheme		
Contrasting fascia finish, if contrasting fascia selected		
• Fabric price group 1	No cost	Specify fabric color number.
• Fabric price group 2	+\$ 30	Specify fabric color number.
• Fabric price group 3	+\$ 45	Specify fabric color number.
• Fabric price group 4	+\$ 62	Specify fabric color number.
• Fabric price group 5	+\$ 78	Specify fabric color number.
• Fabric price group 6	+\$ 96	Specify fabric color number.
• Fabric price group 7	+\$110	Specify fabric color number.
• Fabric price group 8	+\$141	Specify fabric color number.
• Fabric price group 9	+\$173	Specify fabric color number.
• Fabric price group 10	+\$195	Specify fabric color number.
• Elmosoft leather upholstery	+\$412	Specify Elmosoft leather color number.
• Steelcase vinyl	+\$ 29	Specify vinyl color number.
• Customer's Own Material (COM)	No cost	► See <i>Surface Materials Reference Manual</i> .
Contrasting sides finish, if contrasting side selected		
• Fabric price group 1	No cost	Specify fabric color number.
• Fabric price group 2	+\$ 25	Specify fabric color number.
• Fabric price group 3	+\$ 47	Specify fabric color number.
• Fabric price group 4	+\$ 66	Specify fabric color number.
• Fabric price group 5	+\$ 83	Specify fabric color number.
• Fabric price group 6	+\$102	Specify fabric color number.
• Fabric price group 7	+\$118	Specify fabric color number.
• Fabric price group 8	+\$149	Specify fabric color number.
• Fabric price group 9	+\$183	Specify fabric color number.
• Fabric price group 10	+\$208	Specify fabric color number.
• Elmosoft leather upholstery	+\$438	Specify Elmosoft leather color number.
• Steelcase vinyl	+\$ 25	Specify vinyl color number.
• Customer's Own Material (COM)	No cost	► See <i>Surface Materials Reference Manual</i> .
Power Configuration		
Power type		
• No power	No cost	Specify <i>with no power</i> .
• Power block	+\$330	Specify <i>with power block</i> .
• Two power blocks	+\$660	Specify <i>with two power blocks</i> .
Outlet configuration		
• Three power	No cost	Specify <i>with 3 power</i> .
• Two power, one USB	+\$117	Specify <i>with 2 power, 1 USB</i> .
Power plug type		
• Standard NEMA 5–15 3 prong	No cost	Specify <i>with NEMA</i> .
• Low profile plug	+\$ 26	Specify <i>with low profile plug</i> .
Tamper resistant		
• No tamper resistant	No cost	Specify <i>with no tamper resistant</i> .
• Tamper resistant	+\$ 20	Specify <i>with tamper resistant</i> .

Tip: Power is provided by a 72" power cord.

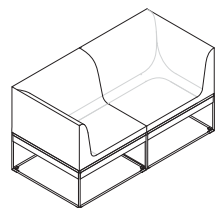

Specification Information				
Dimensions			Style Number	Base Price
D	W	H		
30"	60"	31"	STLLNG2AR2	\$4038



Umami Lounge

Corner, Single

SIN 711.16

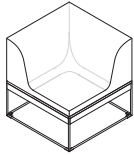

Tip: Only a single material scheme can be selected. For example, both contrasting fascia and contrasting front cannot be selected together. If more than one material scheme is desired, contact a specials representative.

Standard Includes	Required to Specify
<ul style="list-style-type: none"> ▶ Need help? Product details, page 276 • Seat upholstery: fabric price group 1 • Fascia: monolithic, matches top • Frame: paint price group 1 • Ships fully assembled • Attachment package 	<ol style="list-style-type: none"> 1 Style number 2 Fabric color number for seat 3 Paint color number for frame 4 Material scheme (see below under Required Selections) 5 Options, if selected (see below) <p>▶ See <i>Surface Materials</i>, page 432</p>

Material Scheme	Required Selections	Price	Required to Specify
	<ul style="list-style-type: none"> • Monolithic • Contrasting fascia • Contrasting front left • Contrasting front right • Contrasting back left • Contrasting back right • Contrasting front left and right • Contrasting back left and right 	<ul style="list-style-type: none"> No cost No cost No cost No cost No cost No cost No cost No cost 	<p>Specify <i>with monolithic</i>.</p> <p>Specify <i>with contrasting fascia</i>.</p> <p>Specify <i>with contrasting front left</i>.</p> <p>Specify <i>with contrasting front right</i>.</p> <p>Specify <i>with contrasting back left</i>.</p> <p>Specify <i>with contrasting back right</i>.</p> <p>Specify <i>with contrasting front left and right</i>.</p> <p>Specify <i>with contrasting back left and right</i>.</p>

Surface Materials	Options	Price	Required to Specify
	<p>Seat finish</p> <ul style="list-style-type: none"> • Fabric price group 1 • Fabric price group 2 • Fabric price group 3 • Fabric price group 4 • Fabric price group 5 • Fabric price group 6 • Fabric price group 7 • Fabric price group 8 • Fabric price group 9 • Fabric price group 10 • Elmosoft leather upholstery • Steelcase vinyl • Customer's Own Material (COM) 	<ul style="list-style-type: none"> No cost +\$ 53 +\$ 98 +\$138 +\$174 +\$213 +\$246 +\$311 +\$383 +\$435 +\$831 +\$ 53 No cost 	<p>Specify fabric color number.</p> <p>Specify fabric color number.</p> <p>Specify fabric color number.</p> <p>Specify fabric color number.</p> <p>Specify fabric color number.</p> <p>Specify fabric color number.</p> <p>Specify fabric color number.</p> <p>Specify fabric color number.</p> <p>Specify fabric color number.</p> <p>Specify fabric color number.</p> <p>Specify fabric color number.</p> <p>Specify Elmosoft leather color number.</p> <p>Specify vinyl color number.</p> <p>▶ See <i>Surface Materials Reference Manual</i>.</p>
	<p>Frame finish</p> <ul style="list-style-type: none"> • Paint price group 1 • Paint price group 2 • Paint price group 3 	<ul style="list-style-type: none"> No cost +\$ 50 +\$107 	<p>Specify paint color number.</p> <p>Specify paint color number.</p> <p>Specify paint color number.</p>

▶ Options, continued on next page

► Options, continued from previous page

Options	Price	Required to Specify
Contrasting Material Scheme		
Contrasting fascia finish, if contrasting fascia selected		
• Fabric price group 1	No cost	Specify fabric color number.
• Fabric price group 2	+\$ 19	Specify fabric color number.
• Fabric price group 3	+\$ 28	Specify fabric color number.
• Fabric price group 4	+\$ 39	Specify fabric color number.
• Fabric price group 5	+\$ 49	Specify fabric color number.
• Fabric price group 6	+\$ 60	Specify fabric color number.
• Fabric price group 7	+\$ 69	Specify fabric color number.
• Fabric price group 8	+\$ 88	Specify fabric color number.
• Fabric price group 9	+\$108	Specify fabric color number.
• Fabric price group 10	+\$122	Specify fabric color number.
• Elmosoft leather upholstery	+\$258	Specify Elmosoft leather color number.
• Steelcase vinyl	+\$ 18	Specify vinyl color number.
• Customer's Own Material (COM)	No cost	► See <i>Surface Materials Reference Manual</i> .
Contrasting sides finish, if contrasting side selected		
• Fabric price group 1	No cost	Specify fabric color number.
• Fabric price group 2	+\$ 19	Specify fabric color number.
• Fabric price group 3	+\$ 28	Specify fabric color number.
• Fabric price group 4	+\$ 39	Specify fabric color number.
• Fabric price group 5	+\$ 49	Specify fabric color number.
• Fabric price group 6	+\$ 60	Specify fabric color number.
• Fabric price group 7	+\$ 69	Specify fabric color number.
• Fabric price group 8	+\$ 88	Specify fabric color number.
• Fabric price group 9	+\$108	Specify fabric color number.
• Fabric price group 10	+\$122	Specify fabric color number.
• Elmosoft leather upholstery	+\$258	Specify Elmosoft leather color number.
• Steelcase vinyl	+\$ 18	Specify vinyl color number.
• Customer's Own Material (COM)	No cost	► See <i>Surface Materials Reference Manual</i> .
Power Configuration		
Power type		
• No power	No cost	Specify <i>with no power</i> .
• Power block	+\$330	Specify <i>with power block</i> .
Outlet configuration		
• Three power	No cost	Specify <i>with 3 power</i> .
• Two power, one USB	+\$117	Specify <i>with 2 power, 1 USB</i> .
Power plug type		
• Standard NEMA 5–15 3 prong	No cost	Specify <i>with NEMA</i> .
• Low profile plug	+\$ 26	Specify <i>with low profile plug</i> .
Tamper resistant		
• No tamper resistant	No cost	Specify <i>with no tamper resistant</i> .
• Tamper resistant	+\$ 20	Specify <i>with tamper resistant</i> .

Tip: Power is provided by a 72" power cord.



Specification Information				
Dimensions			Style	Base
D	W	H	Number	Price
30"	30"	31"	STLLNGCR1	\$2565

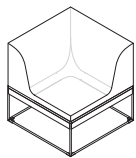

Umami Lounge

End Cap

SIN 711.16

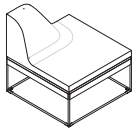

Tip: The end cap position is determined based on the end of a lounge run that you are ganging the end cap to. For example, if attaching to the right end of a lounge run, it would be a right position end cap.

Tip: Only a single material scheme can be selected. For example, both contrasting fascia and contrasting front cannot be selected together. If more than one material scheme is desired, contact a specials representative.

Standard Includes	Required to Specify
<ul style="list-style-type: none"> ▶ Need help? Product details, page 276 • Seat upholstery: fabric price group 1 • Fascia: monolithic, matches top • Frame: paint price group 1 • Ships fully assembled • Attachment package 	<ol style="list-style-type: none"> 1 Style number 2 Fabric color number for seat 3 Paint color number for frame 4 Material scheme (see below under Required Selections) 5 Arm position (see below under Required Selections) 6 Options, if selected (see below) <p>▶ See <i>Surface Materials</i>, page 432</p>

	Required Selections	Price	Required to Specify
Material Scheme	<ul style="list-style-type: none"> • Monolithic • Contrasting fascia • Contrasting front • Contrasting back • Contrasting left • Contrasting right • Contrasting front and back • Contrasting left and right 	<ul style="list-style-type: none"> No cost No cost No cost No cost No cost No cost No cost No cost 	<ul style="list-style-type: none"> Specify <i>with monolithic</i>. Specify <i>with contrasting fascia</i>. Specify <i>with contrasting front</i>. Specify <i>with contrasting back</i>. Specify <i>with contrasting left</i>. Specify <i>with contrasting right</i>. Specify <i>with contrasting front and back</i>. Specify <i>with contrasting left and right</i>.
Arm Position	<ul style="list-style-type: none"> • Left arm • Right arm 	<ul style="list-style-type: none"> No cost No cost 	<ul style="list-style-type: none"> Specify <i>with left arm</i>. Specify <i>with right arm</i>.

	Options	Price	Required to Specify
Surface Materials	<p>Seat finish</p> <ul style="list-style-type: none"> • Fabric price group 1 • Fabric price group 2 • Fabric price group 3 • Fabric price group 4 • Fabric price group 5 • Fabric price group 6 • Fabric price group 7 • Fabric price group 8 • Fabric price group 9 • Fabric price group 10 • Elmosoft leather upholstery • Steelcase vinyl • Customer's Own Material (COM) <p>Frame finish</p> <ul style="list-style-type: none"> • Paint price group 1 • Paint price group 2 • Paint price group 3 	<ul style="list-style-type: none"> No cost +\$ 53 +\$ 98 +\$138 +\$174 +\$213 +\$246 +\$311 +\$383 +\$435 +\$831 +\$ 53 No cost No cost +\$ 50 +\$107 	<ul style="list-style-type: none"> Specify fabric color number. Specify fabric color number. Specify fabric color number. Specify fabric color number. Specify fabric color number. Specify fabric color number. Specify fabric color number. Specify fabric color number. Specify fabric color number. Specify fabric color number. Specify Elmosoft leather color number. Specify vinyl color number. ▶ See <i>Surface Materials Reference Manual</i>. Specify paint color number. Specify paint color number. Specify paint color number.
Contrasting Material Scheme	<p>Contrasting fascia finish, if contrasting fascia selected</p> <ul style="list-style-type: none"> • Fabric price group 1 • Fabric price group 2 • Fabric price group 3 • Fabric price group 4 • Fabric price group 5 • Fabric price group 6 • Fabric price group 7 • Fabric price group 8 • Fabric price group 9 • Fabric price group 10 • Elmosoft leather upholstery • Steelcase vinyl • Customer's Own Material (COM) 	<ul style="list-style-type: none"> No cost +\$ 19 +\$ 28 +\$ 39 +\$ 49 +\$ 60 +\$ 69 +\$ 88 +\$108 +\$122 +\$258 +\$ 18 No cost 	<ul style="list-style-type: none"> Specify fabric color number. Specify fabric color number. Specify fabric color number. Specify fabric color number. Specify fabric color number. Specify fabric color number. Specify fabric color number. Specify fabric color number. Specify fabric color number. Specify fabric color number. Specify Elmosoft leather color number. Specify vinyl color number. ▶ See <i>Surface Materials Reference Manual</i>.

▶ Options, continued on next page

► Options, continued from previous page

Options	Price	Required to Specify
Contrasting Material Scheme, continued	Contrasting sides finish, if contrasting side selected	
• Fabric price group 1	No cost	Specify fabric color number.
• Fabric price group 2	+\$ 19	Specify fabric color number.
• Fabric price group 3	+\$ 28	Specify fabric color number.
• Fabric price group 4	+\$ 39	Specify fabric color number.
• Fabric price group 5	+\$ 49	Specify fabric color number.
• Fabric price group 6	+\$ 60	Specify fabric color number.
• Fabric price group 7	+\$ 69	Specify fabric color number.
• Fabric price group 8	+\$ 88	Specify fabric color number.
• Fabric price group 9	+\$108	Specify fabric color number.
• Fabric price group 10	+\$122	Specify fabric color number.
• Elmosoft leather upholstery	+\$258	Specify Elmosoft leather color number.
• Steelcase vinyl	+\$ 18	Specify vinyl color number.
• Customer's Own Material (COM)	No cost	► See <i>Surface Materials Reference Manual</i> .
Tables	Table type	
	• No table	Specify <i>with no table</i> .
	• Round table	Specify <i>with round table</i> and select color number.
	• Pill table	Specify <i>with pill table</i> and select color number.
	Table location	
	• Table left	Specify <i>with table left</i> .
	• Table right	Specify <i>with table right</i> .
	Table support finish	
	• Paint price group 1	Specify paint color number.
	• Paint price group 2	Specify paint color number.
	• Paint price group 3	Specify paint color number.
Power Configuration	Power type	
	• No power	Specify <i>with no power</i> .
	• Power block	Specify <i>with power block</i> .
	Outlet configuration	
	• Three power	Specify <i>with 3 power</i> .
	• Two power, one USB	Specify <i>with 2 power, 1 USB</i> .
	Power plug type	
	• Standard NEMA 5–15 3 prong	Specify <i>with NEMA</i> .
	• Low profile plug	Specify <i>with low profile plug</i> .
	Tamper resistant	
	• No tamper resistant	Specify <i>with no tamper resistant</i> .
	• Tamper resistant	Specify <i>with tamper resistant</i> .

Tip: Power is provided by a 72" power cord.

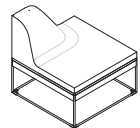

Specification Information				
Dimensions			Style Number	Base Price
D	W	H		
30"	30"	31"	STLLNGEC	\$2565



Umami Screens

Standard Screens

SIN 711.16



Tip: Specify straight clip if end of run and no additional clips required.

Tip: Fascia must be specified when 15"W screen is being placed on a 30" platform/lounge frame.

Tip: If user is seated on the lounge, the side that the 15"W screen will be applied on is the handedness of the fascia. If fascia needs to be applied to the left side of the lounge, then specify fascia left.

► See screen application rules for additional details, page 284.

Standard Includes	Required to Specify
<ul style="list-style-type: none"> ► Need help? Product details, page 276 • Screen: fabric price group 1 • Plastic clips for attachment to other screen (one clip for 48"H screens and two clips for 60"H screens) • Ships full assembled 	<ol style="list-style-type: none"> 1 Style number 2 Size of screen (see below under Required Selections) 3 Screen clips (see below under Required Selections) 4 Fascia (see below under Required Selections) 5 Fabric direction (see below under Required Selections) 6 Fabric color number for screen 7 Options, if selected (see below) <p>► See <i>Surface Materials</i>, page 432</p>

	Required Selections	Price	Required to Specify
Size of Screen	<ul style="list-style-type: none"> • 15"W x 48"H • 30"W x 48"H • 15"W x 60"H • 30"W x 60"H 	Prices at right Prices at right Prices at right Prices at right	Specify with 15"W x 48"H. Specify with 30"W x 48"H. Specify with 15"W x 60"H. Specify with 30"W x 60"H.
Screen Clips	<ul style="list-style-type: none"> • Straight • Corner 	No cost No cost	Specify with straight clip. Specify with corner clip.
Fascia (if 15"W screen selected)	<ul style="list-style-type: none"> • No fascia • Fascia left • Fascia right 	No cost +\$ 60 +\$ 60	Specify with no fascia. Specify with fascia left and select fabric color number for fascia. Specify with fascia right and select fabric color number for fascia.
Fabric Direction	<ul style="list-style-type: none"> • Horizontal • Vertical 	No cost No cost	Specify with horizontal direction. Specify with vertical direction.

	Options	Price	Required to Specify
Surface Materials 15"W x 48"H	Non-contrasting		
	<ul style="list-style-type: none"> • Fabric price group 1 • Fabric price group 2 • Fabric price group 3 • Fabric price group 4 • Fabric price group 5 • Fabric price group 6 • Fabric price group 7 • Fabric price group 8 • Fabric price group 9 • Fabric price group 10 • Customer's Own Material (COM) 	No cost +\$ 24 +\$ 44 +\$ 64 +\$ 76 +\$ 90 +\$106 +\$136 +\$166 +\$186 No cost	Specify fabric color number. Specify fabric color number. Specify fabric color number. Specify fabric color number. Specify fabric color number. Specify fabric color number. Specify fabric color number. Specify fabric color number. Specify fabric color number. Specify fabric color number. Specify fabric color number. Specify fabric color number. Specify fabric color number.
			► See <i>Surface Materials Reference Manual</i> .

► Options, continued on next page

SIN 711.16

► Options, continued from previous page

Tip: Fabrics must be in the same fabric family when specifying contrasting fabrics.

Options	Price	Required to Specify
Surface Materials 15"W x 48"H, continued		
Contrasting fabrics Inside of screen		
• Fabric price group 1	No cost	Specify <i>with contrasting</i> and select fabric color number for inside of screen.
• Fabric price group 2	+\$12	Specify <i>with contrasting</i> and select fabric color number for inside of screen.
• Fabric price group 3	+\$22	Specify <i>with contrasting</i> and select fabric color number for inside of screen.
• Fabric price group 4	+\$32	Specify <i>with contrasting</i> and select fabric color number for inside of screen.
• Fabric price group 5	+\$38	Specify <i>with contrasting</i> and select fabric color number for inside of screen.
• Fabric price group 6	+\$45	Specify <i>with contrasting</i> and select fabric color number for inside of screen.
• Fabric price group 7	+\$53	Specify <i>with contrasting</i> and select fabric color number for inside of screen.
• Fabric price group 8	+\$68	Specify <i>with contrasting</i> and select fabric color number for inside of screen.
• Fabric price group 9	+\$83	Specify <i>with contrasting</i> and select fabric color number for inside of screen.
• Fabric price group 10	+\$93	Specify <i>with contrasting</i> and select fabric color number for inside of screen.
• Customer's Own Material (COM)	No cost	► See <i>Surface Materials Reference Manual</i> .
Outside of screen		
• Fabric price group 1	No cost	Specify <i>with contrasting</i> and select fabric color number for outside of screen.
• Fabric price group 2	+\$12	Specify <i>with contrasting</i> and select fabric color number for outside of screen.
• Fabric price group 3	+\$22	Specify <i>with contrasting</i> and select fabric color number for outside of screen.
• Fabric price group 4	+\$32	Specify <i>with contrasting</i> and select fabric color number for outside of screen.
• Fabric price group 5	+\$38	Specify <i>with contrasting</i> and select fabric color number for outside of screen.
• Fabric price group 6	+\$45	Specify <i>with contrasting</i> and select fabric color number for outside of screen.
• Fabric price group 7	+\$53	Specify <i>with contrasting</i> and select fabric color number for outside of screen.
• Fabric price group 8	+\$68	Specify <i>with contrasting</i> and select fabric color number for outside of screen.
• Fabric price group 9	+\$83	Specify <i>with contrasting</i> and select fabric color number for outside of screen.
• Fabric price group 10	+\$93	Specify <i>with contrasting</i> and select fabric color number for outside of screen.
• Customer's Own Material (COM)	No cost	► See <i>Surface Materials Reference Manual</i> .

► Options, continued on next page

Umami Screens, Standard Screens, continued

SIN 711.16

► Options, continued from previous page

Options	Price	Required to Specify
Surface Materials, 30"W x 48"H		
Non-contrasting		
• Fabric price group 1	No cost	Specify fabric color number.
• Fabric price group 2	+\$ 46	Specify fabric color number.
• Fabric price group 3	+\$ 84	Specify fabric color number.
• Fabric price group 4	+\$122	Specify fabric color number.
• Fabric price group 5	+\$142	Specify fabric color number.
• Fabric price group 6	+\$172	Specify fabric color number.
• Fabric price group 7	+\$200	Specify fabric color number.
• Fabric price group 8	+\$256	Specify fabric color number.
• Fabric price group 9	+\$314	Specify fabric color number.
• Fabric price group 10	+\$352	Specify fabric color number.
• Customer's Own Material (COM)	No cost	► See <i>Surface Materials Reference Manual</i> .

Tip: Fabrics must be in the same fabric family when specifying contrasting fabrics.

Contrasting fabrics Inside of screen		
• Fabric price group 1	No cost	Specify <i>with contrasting</i> and select fabric color number for inside of screen.
• Fabric price group 2	+\$ 23	Specify <i>with contrasting</i> and select fabric color number for inside of screen.
• Fabric price group 3	+\$ 42	Specify <i>with contrasting</i> and select fabric color number for inside of screen.
• Fabric price group 4	+\$ 61	Specify <i>with contrasting</i> and select fabric color number for inside of screen.
• Fabric price group 5	+\$ 71	Specify <i>with contrasting</i> and select fabric color number for inside of screen.
• Fabric price group 6	+\$ 86	Specify <i>with contrasting</i> and select fabric color number for inside of screen.
• Fabric price group 7	+\$100	Specify <i>with contrasting</i> and select fabric color number for inside of screen.
• Fabric price group 8	+\$128	Specify <i>with contrasting</i> and select fabric color number for inside of screen.
• Fabric price group 9	+\$157	Specify <i>with contrasting</i> and select fabric color number for inside of screen.
• Fabric price group 10	+\$176	Specify <i>with contrasting</i> and select fabric color number for inside of screen.
• Customer's Own Material (COM)	No cost	► See <i>Surface Materials Reference Manual</i> .

Outside of screen		
• Fabric price group 1	No cost	Specify <i>with contrasting</i> and select fabric color number for inside of screen.
• Fabric price group 2	+\$ 23	Specify <i>with contrasting</i> and select fabric color number for outside of screen.
• Fabric price group 3	+\$ 42	Specify <i>with contrasting</i> and select fabric color number for outside of screen.
• Fabric price group 4	+\$ 61	Specify <i>with contrasting</i> and select fabric color number for outside of screen.
• Fabric price group 5	+\$ 71	Specify <i>with contrasting</i> and select fabric color number for outside of screen.
• Fabric price group 6	+\$ 86	Specify <i>with contrasting</i> and select fabric color number for outside of screen.
• Fabric price group 7	+\$100	Specify <i>with contrasting</i> and select fabric color number for outside of screen.
• Fabric price group 8	+\$128	Specify <i>with contrasting</i> and select fabric color number for outside of screen.
• Fabric price group 9	+\$157	Specify <i>with contrasting</i> and select fabric color number for outside of screen.
• Fabric price group 10	+\$176	Specify <i>with contrasting</i> and select fabric color number for outside of screen.
• Customer's Own Material (COM)	No cost	► See <i>Surface Materials Reference Manual</i> .

► Options, continued on next page

► Options, continued from previous page

	Options	Price	Required to Specify
Surface Materials, 15"W x 60"H	Non-contrasting		
	• Fabric price group 1	No cost	Specify fabric color number.
	• Fabric price group 2	+\$ 28	Specify fabric color number.
	• Fabric price group 3	+\$ 50	Specify fabric color number.
	• Fabric price group 4	+\$ 74	Specify fabric color number.
	• Fabric price group 5	+\$ 86	Specify fabric color number.
	• Fabric price group 6	+\$104	Specify fabric color number.
	• Fabric price group 7	+\$120	Specify fabric color number.
	• Fabric price group 8	+\$156	Specify fabric color number.
	• Fabric price group 9	+\$190	Specify fabric color number.
	• Fabric price group 10	+\$212	Specify fabric color number.
	• Customer's Own Material (COM)	No cost	► See <i>Surface Materials Reference Manual</i> .
	Contrasting fabrics Inside of screen		
	• Fabric price group 1	No cost	Specify <i>with contrasting</i> and select fabric color number for inside of screen.
	• Fabric price group 2	+\$ 14	Specify <i>with contrasting</i> and select fabric color number for inside of screen.
	• Fabric price group 3	+\$ 25	Specify <i>with contrasting</i> and select fabric color number for inside of screen.
	• Fabric price group 4	+\$ 37	Specify <i>with contrasting</i> and select fabric color number for inside of screen.
	• Fabric price group 5	+\$ 43	Specify <i>with contrasting</i> and select fabric color number for inside of screen.
	• Fabric price group 6	+\$ 52	Specify <i>with contrasting</i> and select fabric color number for inside of screen.
	• Fabric price group 7	+\$ 60	Specify <i>with contrasting</i> and select fabric color number for inside of screen.
	• Fabric price group 8	+\$ 78	Specify <i>with contrasting</i> and select fabric color number for inside of screen.
	• Fabric price group 9	+\$ 95	Specify <i>with contrasting</i> and select fabric color number for inside of screen.
	• Fabric price group 10	+\$106	Specify <i>with contrasting</i> and select fabric color number for inside of screen.
	• Customer's Own Material (COM)	No cost	► See <i>Surface Materials Reference Manual</i> .
	Outside of screen		
	• Fabric price group 1	No cost	Specify <i>with contrasting</i> and select fabric color number for outside of screen.
	• Fabric price group 2	+\$ 14	Specify <i>with contrasting</i> and select fabric color number for outside of screen.
	• Fabric price group 3	+\$ 25	Specify <i>with contrasting</i> and select fabric color number for outside of screen.
	• Fabric price group 4	+\$ 37	Specify <i>with contrasting</i> and select fabric color number for outside of screen.
	• Fabric price group 5	+\$ 43	Specify <i>with contrasting</i> and select fabric color number for outside of screen.
	• Fabric price group 6	+\$ 52	Specify <i>with contrasting</i> and select fabric color number for outside of screen.
	• Fabric price group 7	+\$ 60	Specify <i>with contrasting</i> and select fabric color number for outside of screen.
	• Fabric price group 8	+\$ 78	Specify <i>with contrasting</i> and select fabric color number for outside of screen.
	• Fabric price group 9	+\$ 95	Specify <i>with contrasting</i> and select fabric color number for outside of screen.
	• Fabric price group 10	+\$106	Specify <i>with contrasting</i> and select fabric color number for outside of screen.
	• Customer's Own Material (COM)	No cost	► See <i>Surface Materials Reference Manual</i> .

Tip: Fabrics must be in the same fabric family when specifying contrasting fabrics.

► Options, continued on next page

Umami Screens, Standard Screens, continued

SIN 711.16

► Options, continued from previous page

	Options	Price	Required to Specify
Surface Materials, 30"W x 60"H	Non-contrasting		
	• Fabric price group 1	No cost	Specify fabric color number.
	• Fabric price group 2	+\$ 52	Specify fabric color number.
	• Fabric price group 3	+\$ 96	Specify fabric color number.
	• Fabric price group 4	+\$140	Specify fabric color number.
	• Fabric price group 5	+\$164	Specify fabric color number.
	• Fabric price group 6	+\$196	Specify fabric color number.
	• Fabric price group 7	+\$230	Specify fabric color number.
	• Fabric price group 8	+\$294	Specify fabric color number.
	• Fabric price group 9	+\$360	Specify fabric color number.
	• Fabric price group 10	+\$404	Specify fabric color number.
	• Customer's Own Material (COM)	No cost	► See <i>Surface Materials Reference Manual</i> .
	Contrasting fabrics		
	Inside of screen		
	• Fabric price group 1	No cost	Specify <i>with contrasting</i> and select fabric color number for inside of screen.
	• Fabric price group 2	+\$ 26	Specify <i>with contrasting</i> and select fabric color number for inside of screen.
	• Fabric price group 3	+\$ 48	Specify <i>with contrasting</i> and select fabric color number for inside of screen.
	• Fabric price group 4	+\$ 70	Specify <i>with contrasting</i> and select fabric color number for inside of screen.
	• Fabric price group 5	+\$ 82	Specify <i>with contrasting</i> and select fabric color number for inside of screen.
	• Fabric price group 6	+\$ 98	Specify <i>with contrasting</i> and select fabric color number for inside of screen.
	• Fabric price group 7	+\$115	Specify <i>with contrasting</i> and select fabric color number for inside of screen.
	• Fabric price group 8	+\$147	Specify <i>with contrasting</i> and select fabric color number for inside of screen.
	• Fabric price group 9	+\$180	Specify <i>with contrasting</i> and select fabric color number for inside of screen.
	• Fabric price group 10	+\$202	Specify <i>with contrasting</i> and select fabric color number for inside of screen.
	• Customer's Own Material (COM)	No cost	► See <i>Surface Materials Reference Manual</i> .
	Outside of screen		
	• Fabric price group 1	No cost	Specify <i>with contrasting</i> and select fabric color number for outside of screen.
	• Fabric price group 2	+\$ 26	Specify <i>with contrasting</i> and select fabric color number for outside of screen.
	• Fabric price group 3	+\$ 48	Specify <i>with contrasting</i> and select fabric color number for outside of screen.
	• Fabric price group 4	+\$ 70	Specify <i>with contrasting</i> and select fabric color number for outside of screen.
	• Fabric price group 5	+\$ 82	Specify <i>with contrasting</i> and select fabric color number for outside of screen.
	• Fabric price group 6	+\$ 98	Specify <i>with contrasting</i> and select fabric color number for outside of screen.
	• Fabric price group 7	+\$115	Specify <i>with contrasting</i> and select fabric color number for outside of screen.
	• Fabric price group 8	+\$147	Specify <i>with contrasting</i> and select fabric color number for outside of screen.
	• Fabric price group 9	+\$180	Specify <i>with contrasting</i> and select fabric color number for outside of screen.
	• Fabric price group 10	+\$202	Specify <i>with contrasting</i> and select fabric color number for outside of screen.
	• Customer's Own Material (COM)	No cost	► See <i>Surface Materials Reference Manual</i> .

Tip: Fabrics must be in the same fabric family when specifying contrasting fabrics.

Specification Information

• Dimensions • Depth	• Style • Number	Base Prices			
		• 15"W x 48"H	• 30"W x 48"H	• 15"W x 60"H	• 30"W x 60"H
5/8"	STLSCRPL	\$383	\$450	\$536	\$630
.



Umami Screens

Spanner Screens

SIN 711.16

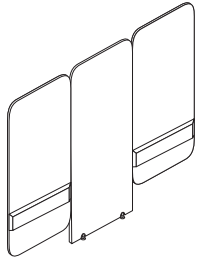

Tip: Spanner screens are not allowed to be attached to a platform or end cap lounge.

Tip: Specify straight clip if end of run and no additional clips required.

Tip: Fabrics will only be applied vertically on spanner screens.

Tip: If you want other screens to match spanner screens, make sure to specify vertical application on standard screens.

► See screen application rules for additional details, page 284.

Tip: Fabrics must be in the same fabric family when specifying contrasting fabrics.

Standard Includes		Required to Specify
► Need help? Product details, page 276	<ul style="list-style-type: none"> • Three 30"W screens, if 90"W selected: fabric price group 1 • Two 30"W screens and one 45"W center screen, if 105"W selected: fabric price group 1 • Plastic clips for attachment to other screen (one clip for 48"H screens and two clips for 60"H screens) • Ships full assembled 	<ol style="list-style-type: none"> 1 Style number 2 Size of screen (see below under Required Selections) 3 Screen clips (see below under Required Selections) 4 Fabric direction (see below under Required Selections) 5 Fabric color number for screen 6 Options, if selected (see below) <p>► See <i>Surface Materials</i>, page 432</p>

Required Selections	Price	Required to Specify
Size of Screen		
• 90"W x 48"H	Prices at right	Specify with 90"W x 48"H.
• 105"W x 48"H	Prices at right	Specify with 105"W x 48"H.
• 90"W x 60"H	Prices at right	Specify with 90"W x 60"H.
• 105"W x 60"H	Prices at right	Specify with 105"W x 60"H.

Required Selections	Price	Required to Specify
Screen Clips		
• Straight	No cost	Specify with straight clip.
• Corner	No cost	Specify with corner clip.

Options	Price	Required to Specify
Surface Materials		
90"W x 48"H		
Non-contrasting		
• Fabric price group 1	No cost	Specify fabric color number.
• Fabric price group 2	+\$ 72	Specify fabric color number.
• Fabric price group 3	+\$132	Specify fabric color number.
• Fabric price group 4	+\$192	Specify fabric color number.
• Fabric price group 5	+\$228	Specify fabric color number.
• Fabric price group 6	+\$270	Specify fabric color number.
• Fabric price group 7	+\$318	Specify fabric color number.
• Fabric price group 8	+\$408	Specify fabric color number.
• Fabric price group 9	+\$498	Specify fabric color number.
• Fabric price group 10	+\$558	Specify fabric color number.
• Customer's Own Material (COM)	No cost	► See <i>Surface Materials Reference Manual</i> .

Options	Price	Required to Specify
Contrasting fabrics		
Inside of screen		
• Fabric price group 1	No cost	Specify with contrasting and select fabric color number for inside of screen.
• Fabric price group 2	+\$ 36	Specify with contrasting and select fabric color number for inside of screen.
• Fabric price group 3	+\$ 66	Specify with contrasting and select fabric color number for inside of screen.
• Fabric price group 4	+\$ 96	Specify with contrasting and select fabric color number for inside of screen.
• Fabric price group 5	+\$114	Specify with contrasting and select fabric color number for inside of screen.
• Fabric price group 6	+\$135	Specify with contrasting and select fabric color number for inside of screen.
• Fabric price group 7	+\$159	Specify with contrasting and select fabric color number for inside of screen.
• Fabric price group 8	+\$204	Specify with contrasting and select fabric color number for inside of screen.
• Fabric price group 9	+\$249	Specify with contrasting and select fabric color number for inside of screen.
• Fabric price group 10	+\$279	Specify with contrasting and select fabric color number for inside of screen.
• Customer's Own Material (COM)	No cost	► See <i>Surface Materials Reference Manual</i> .

► Options, continued on next page

SIN 711.16

► Options, continued from previous page

	Options	Price	Required to Specify
Surface Materials 90"W x 48"H, continued	Outside of screen		
	• Fabric price group 1	No cost	Specify <i>with contrasting</i> and select fabric color number for outside of screen.
	• Fabric price group 2	+\$ 36	Specify <i>with contrasting</i> and select fabric color number for outside of screen.
	• Fabric price group 3	+\$ 66	Specify <i>with contrasting</i> and select fabric color number for outside of screen.
	• Fabric price group 4	+\$ 96	Specify <i>with contrasting</i> and select fabric color number for outside of screen.
	• Fabric price group 5	+\$ 114	Specify <i>with contrasting</i> and select fabric color number for outside of screen.
	• Fabric price group 6	+\$ 135	Specify <i>with contrasting</i> and select fabric color number for outside of screen.
	• Fabric price group 7	+\$ 159	Specify <i>with contrasting</i> and select fabric color number for outside of screen.
	• Fabric price group 8	+\$ 204	Specify <i>with contrasting</i> and select fabric color number for outside of screen.
	• Fabric price group 9	+\$ 249	Specify <i>with contrasting</i> and select fabric color number for outside of screen.
	• Fabric price group 10	+\$ 279	Specify <i>with contrasting</i> and select fabric color number for outside of screen.
	• Customer's Own Material (COM)	No cost	► See <i>Surface Materials Reference Manual</i> .
105"W x 48"H	Non-contrasting		
	• Fabric price group 1	No cost	Specify fabric color number.
	• Fabric price group 2	+\$ 138	Specify fabric color number.
	• Fabric price group 3	+\$ 252	Specify fabric color number.
	• Fabric price group 4	+\$ 366	Specify fabric color number.
	• Fabric price group 5	+\$ 426	Specify fabric color number.
	• Fabric price group 6	+\$ 516	Specify fabric color number.
	• Fabric price group 7	+\$ 600	Specify fabric color number.
	• Fabric price group 8	+\$ 768	Specify fabric color number.
	• Fabric price group 9	+\$ 942	Specify fabric color number.
	• Fabric price group 10	+\$1056	Specify fabric color number.
	• Customer's Own Material (COM)	No cost	► See <i>Surface Materials Reference Manual</i> .
	Contrasting fabrics		
	Inside of screen		
	• Fabric price group 1	No cost	Specify <i>with contrasting</i> and select fabric color number for inside of screen.
	• Fabric price group 2	+\$ 69	Specify <i>with contrasting</i> and select fabric color number for inside of screen.
	• Fabric price group 3	+\$ 126	Specify <i>with contrasting</i> and select fabric color number for inside of screen.
	• Fabric price group 4	+\$ 183	Specify <i>with contrasting</i> and select fabric color number for inside of screen.
	• Fabric price group 5	+\$ 213	Specify <i>with contrasting</i> and select fabric color number for inside of screen.
	• Fabric price group 6	+\$ 258	Specify <i>with contrasting</i> and select fabric color number for inside of screen.
	• Fabric price group 7	+\$ 300	Specify <i>with contrasting</i> and select fabric color number for inside of screen.
	• Fabric price group 8	+\$ 384	Specify <i>with contrasting</i> and select fabric color number for inside of screen.
	• Fabric price group 9	+\$ 471	Specify <i>with contrasting</i> and select fabric color number for inside of screen.
	• Fabric price group 10	+\$ 528	Specify <i>with contrasting</i> and select fabric color number for inside of screen.
	• Customer's Own Material (COM)	No cost	► See <i>Surface Materials Reference Manual</i> .

Tip: Fabrics must be in the same fabric family when specifying contrasting fabrics.

► Options, continued on next page

Umami Screens, Spanner Screens, continued

SIN 711.16

► Options, continued from previous page

	Options	Price	Required to Specify
Surface Materials, 105"W x 48"H continued	Outside of screen		
	• Fabric price group 1	No cost	Specify <i>with contrasting</i> and select fabric color number for outside of screen.
	• Fabric price group 2	+\$ 69	Specify <i>with contrasting</i> and select fabric color number for outside of screen.
	• Fabric price group 3	+\$126	Specify <i>with contrasting</i> and select fabric color number for outside of screen.
	• Fabric price group 4	+\$183	Specify <i>with contrasting</i> and select fabric color number for outside of screen.
	• Fabric price group 5	+\$213	Specify <i>with contrasting</i> and select fabric color number for outside of screen.
	• Fabric price group 6	+\$258	Specify <i>with contrasting</i> and select fabric color number for outside of screen.
	• Fabric price group 7	+\$300	Specify <i>with contrasting</i> and select fabric color number for outside of screen.
	• Fabric price group 8	+\$384	Specify <i>with contrasting</i> and select fabric color number for outside of screen.
	• Fabric price group 9	+\$471	Specify <i>with contrasting</i> and select fabric color number for outside of screen.
	• Fabric price group 10	+\$528	Specify <i>with contrasting</i> and select fabric color number for outside of screen.
	• Customer's Own Material (COM)	No cost	► See <i>Surface Materials Reference Manual</i> .
90"W x 60"H	Non-contrasting		
	• Fabric price group 1	No cost	Specify fabric color number.
	• Fabric price group 2	+\$ 84	Specify fabric color number.
	• Fabric price group 3	+\$150	Specify fabric color number.
	• Fabric price group 4	+\$222	Specify fabric color number.
	• Fabric price group 5	+\$258	Specify fabric color number.
	• Fabric price group 6	+\$312	Specify fabric color number.
	• Fabric price group 7	+\$360	Specify fabric color number.
	• Fabric price group 8	+\$468	Specify fabric color number.
	• Fabric price group 9	+\$570	Specify fabric color number.
	• Fabric price group 10	+\$636	Specify fabric color number.
	• Customer's Own Material (COM)	No cost	► See <i>Surface Materials Reference Manual</i> .
	Contrasting fabrics		
	Inside of screen		
	• Fabric price group 1	No cost	Specify <i>with contrasting</i> and select fabric color number for inside of screen.
	• Fabric price group 2	+\$ 42	Specify <i>with contrasting</i> and select fabric color number for inside of screen.
	• Fabric price group 3	+\$ 75	Specify <i>with contrasting</i> and select fabric color number for inside of screen.
	• Fabric price group 4	+\$111	Specify <i>with contrasting</i> and select fabric color number for inside of screen.
	• Fabric price group 5	+\$129	Specify <i>with contrasting</i> and select fabric color number for inside of screen.
	• Fabric price group 6	+\$156	Specify <i>with contrasting</i> and select fabric color number for inside of screen.
	• Fabric price group 7	+\$180	Specify <i>with contrasting</i> and select fabric color number for inside of screen.
	• Fabric price group 8	+\$234	Specify <i>with contrasting</i> and select fabric color number for inside of screen.
	• Fabric price group 9	+\$285	Specify <i>with contrasting</i> and select fabric color number for inside of screen.
	• Fabric price group 10	+\$318	Specify <i>with contrasting</i> and select fabric color number for inside of screen.
	• Customer's Own Material (COM)	No cost	► See <i>Surface Materials Reference Manual</i> .

Tip: Fabrics must be in the same fabric family when specifying contrasting fabrics.

► Options, continued on next page

► Options, continued from previous page

	Options	Price	Required to Specify
Surface Materials, 90"W x 60"H continued	Outside of screen		
	• Fabric price group 1	No cost	Specify <i>with contrasting</i> and select fabric color number for outside of screen.
	• Fabric price group 2	+\$ 42	Specify <i>with contrasting</i> and select fabric color number for outside of screen.
	• Fabric price group 3	+\$ 75	Specify <i>with contrasting</i> and select fabric color number for outside of screen.
	• Fabric price group 4	+\$ 111	Specify <i>with contrasting</i> and select fabric color number for outside of screen.
	• Fabric price group 5	+\$ 129	Specify <i>with contrasting</i> and select fabric color number for outside of screen.
	• Fabric price group 6	+\$ 156	Specify <i>with contrasting</i> and select fabric color number for outside of screen.
	• Fabric price group 7	+\$ 180	Specify <i>with contrasting</i> and select fabric color number for outside of screen.
	• Fabric price group 8	+\$ 234	Specify <i>with contrasting</i> and select fabric color number for outside of screen.
	• Fabric price group 9	+\$ 285	Specify <i>with contrasting</i> and select fabric color number for outside of screen.
	• Fabric price group 10	+\$ 318	Specify <i>with contrasting</i> and select fabric color number for outside of screen.
	• Customer's Own Material (COM)	No cost	► See <i>Surface Materials Reference Manual</i> .
105"W x 60"H	Non-contrasting		
	• Fabric price group 1	No cost	Specify fabric color number.
	• Fabric price group 2	+\$ 156	Specify fabric color number.
	• Fabric price group 3	+\$ 288	Specify fabric color number.
	• Fabric price group 4	+\$ 420	Specify fabric color number.
	• Fabric price group 5	+\$ 492	Specify fabric color number.
	• Fabric price group 6	+\$ 588	Specify fabric color number.
	• Fabric price group 7	+\$ 690	Specify fabric color number.
	• Fabric price group 8	+\$ 882	Specify fabric color number.
	• Fabric price group 9	+\$1080	Specify fabric color number.
	• Fabric price group 10	+\$1212	Specify fabric color number.
	• Customer's Own Material (COM)	No cost	► See <i>Surface Materials Reference Manual</i> .
	Contrasting fabrics		
	Inside of screen		
	• Fabric price group 1	No cost	Specify <i>with contrasting</i> and select fabric color number for inside of screen.
	• Fabric price group 2	+\$ 78	Specify <i>with contrasting</i> and select fabric color number for inside of screen.
	• Fabric price group 3	+\$ 144	Specify <i>with contrasting</i> and select fabric color number for inside of screen.
	• Fabric price group 4	+\$ 210	Specify <i>with contrasting</i> and select fabric color number for inside of screen.
	• Fabric price group 5	+\$ 246	Specify <i>with contrasting</i> and select fabric color number for inside of screen.
	• Fabric price group 6	+\$ 294	Specify <i>with contrasting</i> and select fabric color number for inside of screen.
	• Fabric price group 7	+\$ 345	Specify <i>with contrasting</i> and select fabric color number for inside of screen.
	• Fabric price group 8	+\$ 441	Specify <i>with contrasting</i> and select fabric color number for inside of screen.
	• Fabric price group 9	+\$ 540	Specify <i>with contrasting</i> and select fabric color number for inside of screen.
	• Fabric price group 10	+\$ 606	Specify <i>with contrasting</i> and select fabric color number for inside of screen.
	• Customer's Own Material (COM)	No cost	► See <i>Surface Materials Reference Manual</i> .

Tip: Fabrics must be in the same fabric family when specifying contrasting fabrics.

► Options, continued on next page

Umami Screens, Spanner Screens, continued

SIN 711.16

► Options, continued from previous page

Options	Price	Required to Specify
Surface Materials 105"W x 60"H, continued		
• Outside of screen		
• Fabric price group 1	No cost	Specify <i>with contrasting</i> and select fabric color number for outside of screen.
• Fabric price group 2	+\$ 78	Specify <i>with contrasting</i> and select fabric color number for outside of screen.
• Fabric price group 3	+\$144	Specify <i>with contrasting</i> and select fabric color number for outside of screen.
• Fabric price group 4	+\$210	Specify <i>with contrasting</i> and select fabric color number for outside of screen.
• Fabric price group 5	+\$246	Specify <i>with contrasting</i> and select fabric color number for outside of screen.
• Fabric price group 6	+\$294	Specify <i>with contrasting</i> and select fabric color number for outside of screen.
• Fabric price group 7	+\$345	Specify <i>with contrasting</i> and select fabric color number for outside of screen.
• Fabric price group 8	+\$441	Specify <i>with contrasting</i> and select fabric color number for outside of screen.
• Fabric price group 9	+\$540	Specify <i>with contrasting</i> and select fabric color number for outside of screen.
• Fabric price group 10	+\$606	Specify <i>with contrasting</i> and select fabric color number for outside of screen.
• Customer's Own Material (COM)	No cost	► See <i>Surface Materials Reference Manual</i> .

Specification Information

Dimensions Depth	Style Number	Base Prices			
		90"W x 48"H	105"W x 48"H	90"W x 60"H	105"W x 60"H
5/8"	STLSCRPLS	\$1350	\$1550	\$1890	\$2250

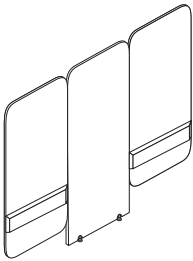

B-Free

B-Free leverages ancillary spaces to create informal and convenient workspaces where teams can collaborate. A variety of casual seating and table options allows workers to quickly connect, while subtle screens promote concentration. Its modular and flexible design allows for spaces that support both individual and group work.

B-Free screens are made of knit material and are available in several colors. Screens come in small and large sizes with left or right applications. Magnets allow screens to connect to one another and/or connect to the large cube.

Occasional tables are available in coffee and corner configurations. They can be placed in between cubes, in front of cubes, on the side of cubes as an end table, or act as a corner piece with a screen configuration.

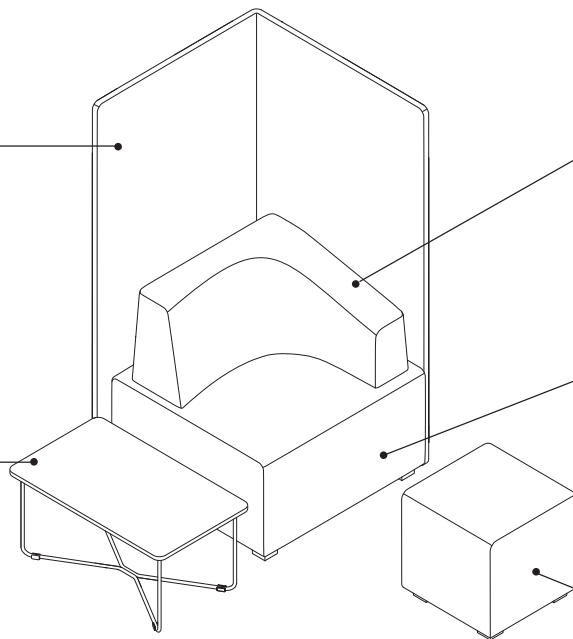

Top block is available on large cube with either a straight application or a corner left or right application. Shown is a corner left application. Top block is contoured and sculpted to provide comfort for multiple postures.

Large cubes can be standalone units or ganged together with other large cube units.

Small cube can be used as a seat or an ottoman. It can be specified with glides or casters.

Actual Dimensions

	Depth	Width	Height	Seat Depth
Large cube	29½"	31"	17⅛"	N.A.
Large cube with top block	29½"	31"	31½"	19"
Small cube	16¾"	16¾"	17⅛"	N.A.
Screen (small)	30½"	32"	59"	N.A.
Screen (large)	30½"	40⅞"	59"	N.A.
Coffee table	29½"	17¾"	15⅛"	N.A.
Corner table	29½"	29½"	15⅛"	N.A.

Product Details

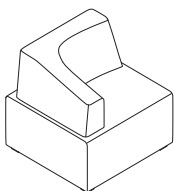

Corner left and right options on large cube integrate as armrests. The backrest is shaped to “wrap” around the user, providing greater lumbar support.



Ganging brackets are discreet and allow cubes to be well aligned when attached together.

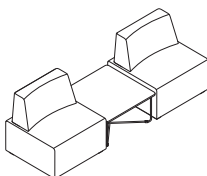

The corner occasional table can be used as a corner piece and/or to bridge together two large cubes. It also fits perfectly next to the cube and inside of the privacy screen, or works well out front.

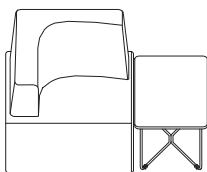

The coffee occasional table fits perfectly next to the cube and works well out in front of the cube.

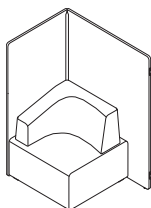

Left and right screens are decided based on the perspective of the user sitting on a cube in front of a large screen. The small side of the screen is on the arm side of the cube. The large side of the screen goes behind the cube. Shown above is a large, right screen application.

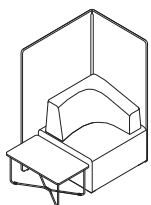

The large screen surrounds the cube and part of a coffee table.

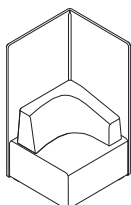

The small screen fits perfectly around the cube.

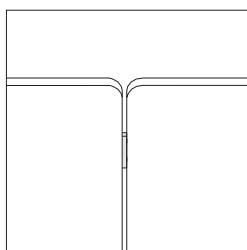

Screen to screen magnets come in a pair and attach two screens together.

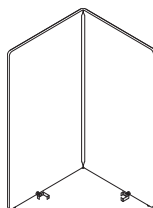

Screen to large cube magnets come in a pair and attach to the bottom of the screen and to the bottom of the large cube.

Surface Materials

Cube and top block

- Fabric
- Vinyl
- Leather
- Elmosoft leather
- Select Surfaces leather
- COL
- COM

Occasional tables

- Top
- Laminate
- Veneer

- Base
- Paint

Screen

- B-Free Knit:

Steelcase Surfaces

5Y58	Light Grey
5Y99	Dark Grey

Select Surfaces

0096	White
1274	Sky
1280	Ice
1288	Teal Blue
2111	Tangerine
2121	Paprika
5306	Leaf
5313	Chartreuse
5314	Lime
7273	Silver
8172	Currant
8179	Red Mittens
8180	Hot Pink

Tip: Warranty and availability of these colors vary and are at the discretion of the supplier.

For more information on Select Surfaces, please refer to the *Surface Materials Reference Manual*.

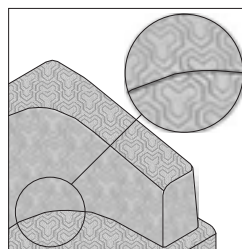

Solid, non-repeat fabrics are recommended for B-Free lounge settings because of the unique geometric shapes. Steelcase will not pattern match fabrics which have a distinct repeating pattern. It is recommended to use one of the standard fabrics, vinyls, leathers, or non-patterned COM/COL.

Programs & Services

▶ See the *Surface Materials Reference Manual* for further detail about programs and services offered for seating.

The Customer's Own Material (COM) Program

offers the opportunity for customers to select fabrics that are not offered through the standard Steelcase surface materials program for use on Steelcase products. Through the COM program, Steelcase will test your materials for application on Steelcase products. Once approved, you can place your order. Steelcase will facilitate the entire ordering process and give you a production schedule. Steelcase will order the COM fabric directly from the textile manufacturer. For up-to-date information regarding fabric test results for all COM fabrics and details regarding yardage requirements for most Seating lines, visit the COM website. To locate the COM website:

- Visit www.steelcase.com

Soil retardants are treatments that provide long-term soil and stain resistance to a fabric without affecting the shade or the integrity of the fabric. The following Steelcase Textiles are available pre-treated with soil retardant. (You do not need to select the soil-retardant option for these fabrics and incur the upcharge.)

- Jacks
- Link
- Spyder

For information on soil retardant fabrics on Select Surfaces, please refer to the *Surface Materials Reference Manual*.

Soil-retardant treatment is available on all other seating fabrics at an additional upcharge per seating unit. To order this option, please select “Soil-Retardant Treatment” under “Optional Accessories.”

For soil-retardant treatment on COMs, please select “Soil-Retardant Treatment” under “Optional Accessories.” Minimums or additional yardage may be required. Please contact the vendor directly for specific information. Extended lead times may be necessary for this service.

Contact your Steelcase Solutions Fulfillment Team Representative at 1.888.STEELCASE (1.888.783.3522) or send an email to lineone@steelcase.com.

B-Free Rectangle and Pint Tables

B-Free offers rectangle and pint tables for standing and high-sit applications making it easy to leverage space across the entire floor plan and create effective workspaces for individual concentration and collaborations with others.

Rectangle tops have square corners.

Tables are 39 1/2"H.

Top is 1" thick with High-Pressure Laminate or veneer and black backer. Laminate tops have 3 mm edge band on all sides. Edge band color is selectable for laminate tops. Veneer tops have 3 mm wood edge that matches the veneer top finish selection.

Pint tops have square corners on the wide end of the table and 2" (50 mm) radius edges on the short end of the table. The pint table has standard dimensions of 32"D (short end: leg width 23 1/4"), 44"D (wide end: leg width 31") x 80"W.

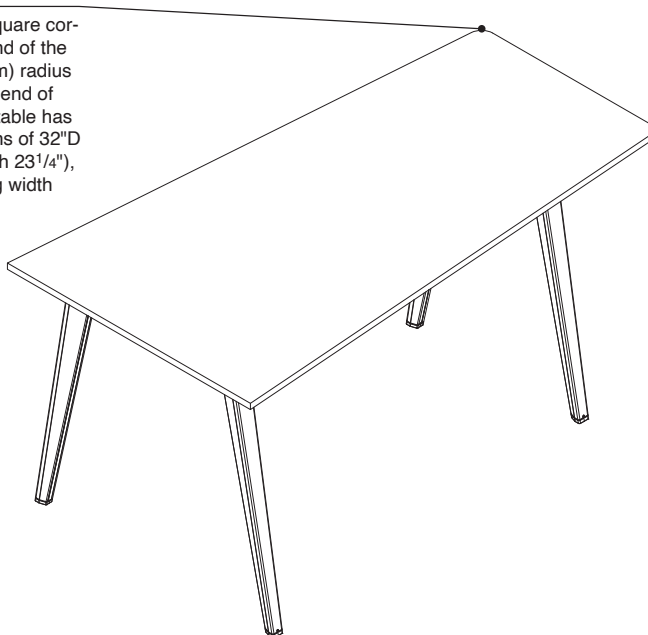
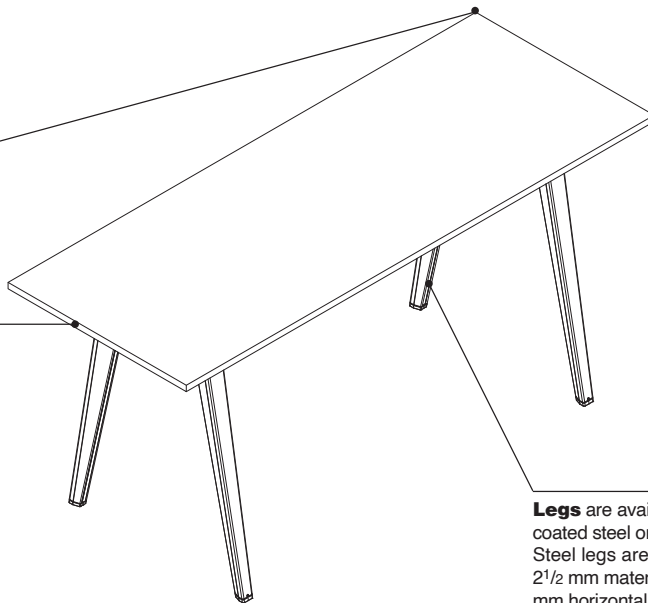

Legs are available in powder coated steel or stained wood. Steel legs are constructed of 2 1/2 mm material bent steel, 3 mm horizontal steel tube, and 3 mm thick powder coated epoxy resin paint. Wood legs are European beech wood.

Legs ship standard with four glides.

- Steel leg table: 5/8" glide adjustment range
- Wood leg table: 7/8" glide adjustment range

Product Details

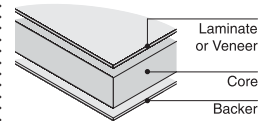

Solid core tops with 1" nominal edge thickness have a particle board core (45 lb cu ft density) with High-Pressure Laminate or wood veneer on the top and a backer applied to the opposite side for a balanced construction. High-Pressure Laminate, wood veneer, and backer are bonded to the core with a PVA adhesive.

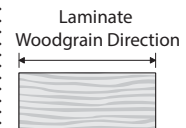

Woodgrain laminates are always oriented with the grain direction running parallel with the length of the table top. You cannot specify woodgrain laminates with end- or side-matched grain directions.



Woodgrain runs parallel to the length on rectangle and pint tops.

Wiring and Cabling

Wood leg profile

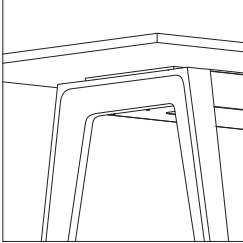

Steel leg profile

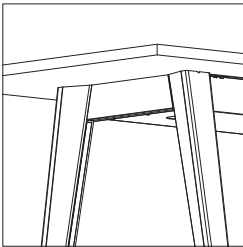

Steel leg tables include integrated wire manager and merle cover in the leg. Tables with wood legs require cable riser for wire management.

Horizontal steel beam, located in the middle of the legs, is constructed of 1 1/4 mm bent steel and powder coated epoxy resin paint.

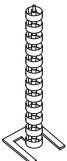

Cable riser is available as an additional accessory for wood legs. This product is sold separately.

▶ Page 337

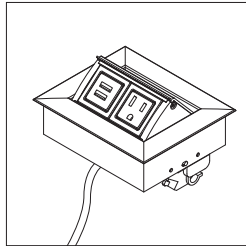
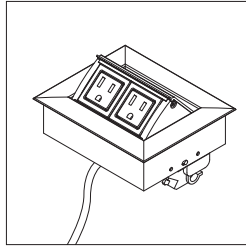

MhoB is a 4" x 5" flip-top power module that mounts at the top surface of the table and can be configured in different power/USB configurations:

- Two receptacles for power
- One power/one dual USB

Single/dual power and USB solutions come standard with a 15-amp, one-circuit power solution with a 10' cord.

▶ See *Power Matrix* on page 326 for available options and power module locations.

MhoB, one power module, is located 10" from the short end of the table; on the centerline of the width/depth specified.

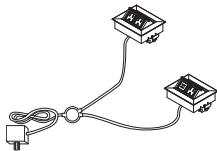

MhoB, two power modules (center or both ends), are connected by a corded system with just one infeed.

Surface Materials

Top

- High-Pressure Laminate (standard)
- Open Line laminate (option)
- Wood veneer (option)
- Customiz stain (option)

Edge

- Plastic on laminate top
- Wood veneer to match veneer top

Steel legs

- Paint

Wood legs

- 3860 Espresso
- 3861 Natural Beech

Power modules

- Paint

B-Free Power Matrix

Power Configuration		48"W	60"W	66"W	72"W	84"W
No Power	24"D 25"D 26"D					
One Power Module	24"D 25"D 26"D					
Two Power Modules	24"D 25"D 26"D					
No Power	32"D 33"D 34"D					
One Power Module	32"D 33"D 34"D					
Two Power Modules	32"D 33"D 34"D					
Two Power Modules	32"D 33"D 34"D					

Tip: Center power position is only available on tables that are at least 32"D x 66"W.

Tip: Power on both ends is only available on tables that are at least 70"W.

Tip: Center and two end power position options will default to two power modules, one with two receptacles for power and one with one receptacle for power/one dual USB port.

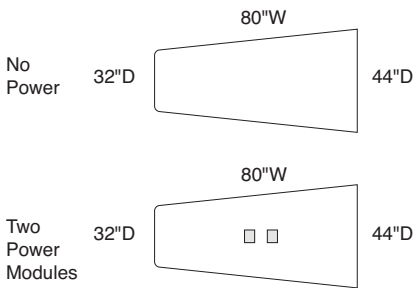

Key

- One Power Module
1 Power/1 USB or 2 Power
- Two Power Modules
Kit includes 2 modules: 1 Power/1 USB,
1 Power/1 USB and 2 Power

No parametric options available on pint tables.

Standard MhoB Power Module Locations

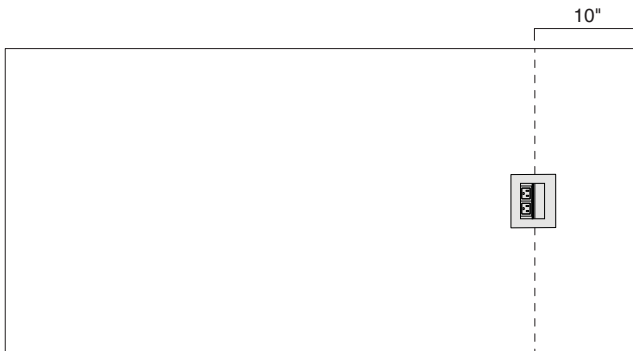

For the power option with one end only, the centerline of the power module is located 10" from the short edge of the table. Power module flips toward the center of the top.

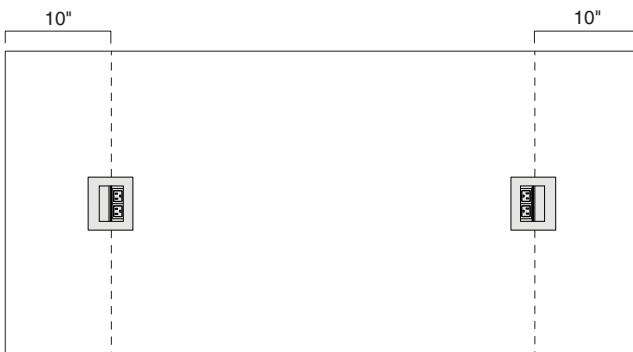

For the power option with both ends, the centerline of each power module is located 10" from the short edge of the table. Power module flips toward the center of the top.

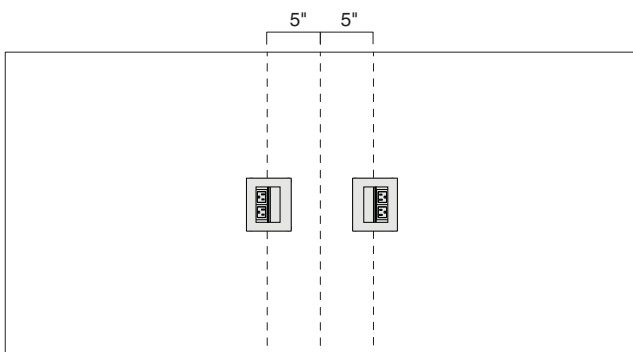

For the center power option, the centerline of each power module is located 5" from the centerline of the table. Power module flips toward the short edge of the top.

B-Free Large Cube

SIN 711.16

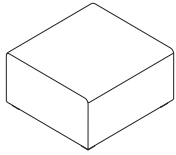

Tip: Large cube with top block has a height of 31 1/2".

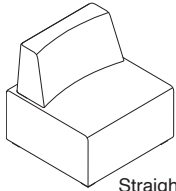

Straight

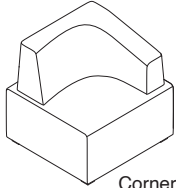

Corner left

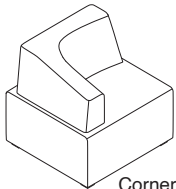

Corner right

Tip: Cubes do not ship with ganging brackets. Ganging brackets, N3LGA, need to be ordered separately.
▶ See page 330

Standard Includes		Required to Specify	
▶ Need help? Product details, page 322	<ul style="list-style-type: none"> • Large cube: fabric • Plastic, hard glides • Shipped fully assembled 	1 Style number	2 Fabric color number for cube
		3 Top block, see below under Required Selections	4 Options, if selected (see below)
		▶ See <i>Surface Materials</i> , page 432.	

Required Selections	Price	Required to Specify
Top Block		
• No top block	No cost	Specify with <i>no top block</i> .
• Straight	+\$500	Specify with <i>straight top block</i> .
• Corner left	+\$550	Specify with <i>corner left top block</i> .
• Corner right	+\$550	Specify with <i>corner right top block</i> .

Options	Price	Required to Specify
Surface Materials		
Cube		
• Fabric price group 1	No cost	Specify fabric color number.
• Fabric price group 2	+\$ 46	Specify fabric color number.
• Fabric price group 3	+\$ 86	Specify fabric color number.
• Fabric price group 4	+\$121	Specify fabric color number.
• Fabric price group 5	+\$152	Specify fabric color number.
• Fabric price group 6	+\$189	Specify fabric color number.
• Fabric price group 7	+\$216	Specify fabric color number.
• Fabric price group 8	+\$273	Specify fabric color number.
• Fabric price group 9	+\$336	Specify fabric color number.
• Fabric price group 10	+\$381	Specify fabric color number.
• Steelcase vinyl	+\$ 40	Specify vinyl color number.
• Steelcase leather upholstery	+\$620	Specify leather color number.
• Select Surfaces leather price group 1	+\$620	▶ See <i>Surface Materials Reference Manual</i> .
• Elmosoft leather upholstery	+\$806	Specify Elmosoft leather color number.
• Select Surfaces leather price group 2	+\$806	▶ See <i>Surface Materials Reference Manual</i> .
• Customer's Own Material (COM)	No cost	▶ See <i>Surface Materials Reference Manual</i> .
• Customer's Own Leather (COL)	+\$ 75	▶ See <i>Surface Materials Reference Manual</i> .
Top Block		
• Fabric price group 1	No cost	Specify fabric color number.
• Fabric price group 2	+\$ 25	Specify fabric color number.
• Fabric price group 3	+\$ 47	Specify fabric color number.
• Fabric price group 4	+\$ 66	Specify fabric color number.
• Fabric price group 5	+\$ 83	Specify fabric color number.
• Fabric price group 6	+\$102	Specify fabric color number.
• Fabric price group 7	+\$118	Specify fabric color number.
• Fabric price group 8	+\$149	Specify fabric color number.
• Fabric price group 9	+\$183	Specify fabric color number.
• Fabric price group 10	+\$208	Specify fabric color number.
• Steelcase vinyl	+\$ 25	Specify vinyl color number.
• Steelcase leather upholstery	+\$350	Specify leather color number.
• Select Surfaces leather price group 1	+\$350	▶ See <i>Surface Materials Reference Manual</i> .
• Elmosoft leather upholstery	+\$455	Specify Elmosoft leather color number.
• Select Surfaces leather price group 2	+\$455	▶ See <i>Surface Materials Reference Manual</i> .
• Customer's Own Material (COM)	No cost	▶ See <i>Surface Materials Reference Manual</i> .
• Customer's Own Leather (COL)	+\$ 75	▶ See <i>Surface Materials Reference Manual</i> .
Soil-retardant treatment	+\$ 25	Specify with <i>soil-retardant treatment</i> .
Glide		
• Soft glide	+\$ 6	Specify with <i>soft glides</i> .

Specification Information

Dimensions			Style	Base
D	W	H	Number	Price
29 1/2"	31"	17 1/8"	N3LCUBEL	\$1000

B-Free Small Cube

SIN 711.16

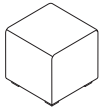

Standard Includes	Required to Specify
<ul style="list-style-type: none"> ▶ Need help? Product details, page 322 • Small cube: fabric • Plastic, hard glides 	<ul style="list-style-type: none"> 1 Style number 2 Fabric color number for cube 3 Options, if selected (see below) ▶ See <i>Surface Materials</i>, page 432

Options	Price	Required to Specify
Surface Materials		
Cube		
• Fabric price group 1	No cost	Specify fabric color number.
• Fabric price group 2	+\$ 25	Specify fabric color number.
• Fabric price group 3	+\$ 47	Specify fabric color number.
• Fabric price group 4	+\$ 66	Specify fabric color number.
• Fabric price group 5	+\$ 83	Specify fabric color number.
• Fabric price group 6	+\$102	Specify fabric color number.
• Fabric price group 7	+\$118	Specify fabric color number.
• Fabric price group 8	+\$149	Specify fabric color number.
• Fabric price group 9	+\$183	Specify fabric color number.
• Fabric price group 10	+\$208	Specify fabric color number.
• Steelcase vinyl	+\$ 25	Specify vinyl color number.
• Steelcase leather upholstery	+\$350	Specify leather color number.
• Select Surfaces leather price group 1	+\$350	▶ See <i>Surface Materials Reference Manual</i> .
• Elmosoft leather upholstery	+\$455	Specify Elmosoft leather color number.
• Select Surfaces leather price group 2	+\$455	▶ See <i>Surface Materials Reference Manual</i> .
• Customer's Own Material (COM)	No cost	▶ See <i>Surface Materials Reference Manual</i> .
• Customer's Own Leather (COL)	+\$ 75	▶ See <i>Surface Materials Reference Manual</i> .
Soil-retardant treatment		
	+\$ 25	Specify with soil-retardant treatment.
Casters/Glides		
• Soft glides	+\$ 6	Specify with soft glides.
• Soft casters	+\$ 24	Specify with soft casters.
• Hard casters	+\$ 50	Specify with hard casters.

Specification Information				
• Dimensions			• Style	• Base
D	W	H	Number	Price
16¾"	16¾"	17½"	N3LCUBES	\$510

B-Free

B-Free Ganging Brackets

SIN 711.16



Standard Includes	Required to Specify
<ul style="list-style-type: none"> ▶ Need help? Product details, page 323 • 10 ganging brackets 	<ul style="list-style-type: none"> Style number

Related Products
<ul style="list-style-type: none"> • B-Free large cube ▶ Page 328 • B-Free small cube ▶ Page 329

Specification Information	
• Style Number	• Price
N3LGA	\$20
•	•
•	•

B-Free Screens

SIN 711.16

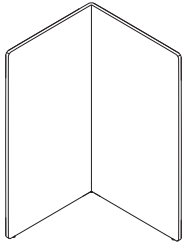

Tip: Small, right application screen is pictured above.

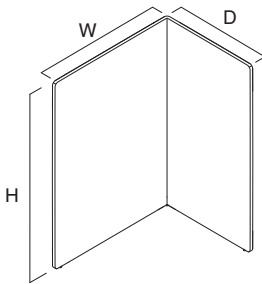

Tip: Large, left application screen is pictured above.

Standard Includes	Required to Specify
-------------------	---------------------

- | | | |
|--|--|--|
| <ul style="list-style-type: none"> ▶ Need help? Product details, page 322 | <ul style="list-style-type: none"> • Screen: steel tubular frame with a polyester cover: knit • Plastic, adjustable glides | <ul style="list-style-type: none"> 1 Style number 2 Knit color number for screen 3 Options, if selected (see below) |
|--|--|--|

Options	Price	Required to Specify
---------	-------	---------------------

Screen Width	<ul style="list-style-type: none"> • Small (32"W) • Large (40⁷/₈"W) 	Prices below Prices below	Specify with <i>small screen</i> . Specify with <i>large screen</i> .
Application	<ul style="list-style-type: none"> • Left application • Right application 	No cost No cost	Specify with <i>left application</i> . Specify with <i>right application</i> .
Connecting Magnets	<ul style="list-style-type: none"> • No connecting magnets • Connecting magnets, screen • Connecting magnets, cube • Connecting magnets, screen and cube 	No cost +\$25 +\$50 +\$75	Specify with <i>no magnets</i> . Specify with <i>screen magnets</i> . Specify with <i>cube magnets</i> . Specify with <i>screen and cube magnets</i> .

Specification Information				
• Dimensions		• Style Number	• Base Prices	
D	H		Small 32"W	Large 40 ⁷ / ₈ "W

30 ¹ / ₂ "	59"	N3LSCREEN	\$950	\$1000
.

B-Free Screen Magnets

SIN 711.16

Standard Includes	Required to Specify
<ul style="list-style-type: none"> ▶ Need help? Product details, page 322 • Pair of magnets 	<ul style="list-style-type: none"> • Style number

Specification Information	
• Style Number	• Price
:	:
:	:

Screen to Screen

N3LMAGSS \$25

:

:

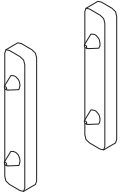

Screen to Large Cube

N3LMAGSC \$50

:

:

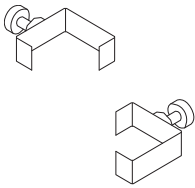

B-Free Occasional Tables

SIN 711.11

Standard Includes	Required to Specify
<ul style="list-style-type: none"> ▶ Need help? Product details, page 322 • Table: High-Pressure Laminate price group 1 surface with plastic edge profile • 12 mm steel wire and 1½ mm thick steel tube base: paint • Fitted with four merle plastic glides clipped onto the framework • Shipped ready to assemble 	<ol style="list-style-type: none"> 1 Style number 2 Laminate color number for table 3 Paint color number for base 4 Options, if selected (see below) <ul style="list-style-type: none"> ▶ See <i>Surface Materials</i>, page 432.

For laminate price group 2 pricing, please refer to the electronic catalog or SmartTools.

Options	Price	Required to Specify
Surface Materials		
High-Pressure Laminate Surface		
• Laminate price group 2	See information at left	Specify laminate color number.
• Open Line laminate	+\$ 69	▶ See <i>Surface Materials Reference Manual</i> .
Wood Veneer Surface		
• Wood veneer	+\$534	Specify wood veneer finish number.
• Premium wood 2	+\$603	Specify Premium wood 2 finish number.
• Premium wood 3	+\$776	Specify Premium wood 3 finish number.
• Customiz stain	+\$534	Specify <i>with Customiz stain</i> .
• Full-fill finish	+\$603	Specify full-fill finish number.
Base		
• Paint price group 1	No cost	Specify paint color number.
• Paint price group 2	+\$ 51	Specify paint color number.
• Paint price group 3	+\$100	Specify paint color number.

Specification Information				
Dimensions			Style	Base
D	W	H	Number	Price

Coffee Table

29½"	17¾"	15⅛"	N3LTABLECF	\$500
:	:	:	:	:

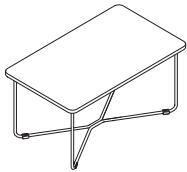

Corner Table

29½"	29½"	15⅛"	N3LTABLECR	\$600
:	:	:	:	:

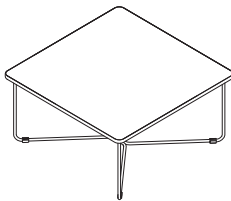

B-Free

B-Free Rectangle Tables

SIN 711.11



Tip: Modular size options are only available for 24"D and 32"D tables.

For laminate price group 2 pricing, please refer to the electronic catalog or SmartTools.

Tip: Premium wood upcharges are in addition to wood veneer upcharge.

Standard Includes	Required to Specify
<ul style="list-style-type: none"> ▶ Need help? Product details, page 324 • Table: 39½"H table with 1" thick particle board core, High-Pressure Laminate price group 1 top • Edge: 3 mm radius profile: plastic • Steel legs: powder coat paint price group 1 	<ol style="list-style-type: none"> 1 Style number 2 Size option (see below under Required Selections) 3 Depth (see below under Required Selections) 4 Width (see below under Required Selections) 5 High-Pressure Laminate color number for top 6 Plastic color number for edge 7 Paint color number for legs 8 Options, if selected (see below) <p>▶ See <i>Surface Materials</i>, page 432</p>

Require Selections	Price	Required to Specify
Size Option		
• Modular	No cost	Specify with modular.
• Parametric	No cost	Specify with parametric.
Depth		
• 24"D	Prices at right	Specify with 24"D.
• 25"D	Prices at right	Specify with 25"D.
• 26"D	Prices at right	Specify with 26"D.
• 32"D	Prices at right	Specify with 32"D.
• 33"D	Prices at right	Specify with 33"D.
• 34"D	Prices at right	Specify with 34"D.
Width		
Modular (24"D and 32"D tables only)		
• 48"W	Prices at right	Specify with 48"W.
• 60"W	Prices at right	Specify with 60"W.
• 66"W	Prices at right	Specify with 66"W.
• 72"W	Prices at right	Specify with 72"W.
• 84"W	Prices at right	Specify with 84"W.
Parametric		
• 48⅞"W-60"W	Prices at right	Specify with 48⅞"W-60"W.
• 60⅞"W-66"W	Prices at right	Specify with 60⅞"W-66"W.
• 66⅞"W-72"W	Prices at right	Specify with 66⅞"W-72"W.
• 72⅞"W-84"W	Prices at right	Specify with 72⅞"W-84"W.

Options	Price	Required to Specify
Surface Materials		
High-Pressure Laminate top		
• Laminate price group 2	See information at left	Specify laminate color number.
• Open Line laminate	+\$ 69 plus cost of laminate	▶ See <i>Surface Materials Reference Manual</i> .
Wood Veneer top		
• Wood veneer	Prices at right	Specify wood veneer finish number.
• Premium wood 2	+\$ 69	Specify Premium wood 2 finish number.
• Premium wood 3	+\$242	Specify Premium wood 3 finish number.
• Customiz stain	No cost	Specify with <i>Customiz stain</i> .
Legs		
Steel legs		
• Paint price group 1	No cost	Specify paint color number.
• Paint price group 2	+\$ 52	Specify paint color number.
• Paint price group 3	+\$110	Specify paint color number.
Wood legs		
• Beech (24"D-26"D)	+\$600	Specify wood finish number.
• Beech (32"D-34"D)	+\$700	Specify wood finish number.

▶ Options, continued on next page

SIN 711.11

► Options, continued from previous page

Options	Price	Required to Specify
Power	• No power • With power	No cost No cost
► Power Matrix, page 326		Specify <i>with no power</i> . Specify <i>with power</i> .
Power position/configuration		
• One end with two power	+\$275	Specify <i>with end and with two power</i> and select paint color number.
• One end with one power/ one dual USB	+\$350	Specify <i>with end and with one power/one USB</i> and select paint color number.
• Center (two receptacles for power and one receptacle for power/one dual USB)	+\$675	Specify <i>with center</i> and select paint color number.
• Both ends (two receptacles for power and one receptacle for power/one dual USB)	+\$675	Specify <i>with two ends</i> and select paint color number.

Related Products

- Cable riser

► Page 337

Tip: Center power position is only available on tables that are at least 32"D x 66"W.

Tip: Power on both ends is only available on tables that are at least 70"W.

Tip: Center and two end power position options will default to two power modules, one with two receptacles for power and one with one receptacle for power/one dual USB port.

Tip: Steel leg tables include integrated wire manager and cover in the leg. Tables with wood legs require cable riser for wire management.

**Specification Information**

• Style Number	• Dimensions D	• Modular Width • Parametric Width	• Base Prices				
			48"W	60"W	66"W	72"W	84"W
			N.A.	48½"W-60"W	60½"W-66"W	66½"W-72"W	72½"W-84"W

High-Pressure Laminate

N3LRECT	24"D, 25"D, or 26"D	\$1800	\$1900	\$2000	\$2100	N.A.
	32"D, 33"D, or 34"D	\$1850	\$1950	\$2050	\$2150	\$2250

Wood Group 1

N3LRECT	24"D, 25"D, or 26"D	\$2350	\$2470	\$2580	\$2685	N.A.
	32"D, 33"D, or 34"D	\$2440	\$2550	\$2655	\$2760	\$2870

B-Free Pint Tables

SIN 711.11



For laminate price group 2 pricing, please refer to the electronic catalog or SmartTools.

Tip: Premium wood upcharges are in addition to wood veneer upcharge.

Tip: Center power position is the only power option available on the pint table.

Tip: Steel leg tables include integrated wire manager and cover in the leg. Tables with wood legs require cable riser for wire management.

Tip: N3LPINT has standard dimensions of 32"D (short end: leg width 23¼"), 44"D (wide end: leg width 31") x 80"W.

Standard Includes	Required to Specify
<ul style="list-style-type: none"> ▶ Need help? Product details, page 324 • Table: 39½"H table with 1" thick particle board core, High-Pressure Laminate price group 1 top • Edge: 3 mm radius profile: plastic • Steel legs: powder coat paint price group 1 	<ol style="list-style-type: none"> 1 Style number 2 High-Pressure Laminate color number for top 3 Plastic color number for edge 4 Paint color number for legs 5 Options, if selected (see below) <ul style="list-style-type: none"> ▶ See <i>Surface Materials</i>, page 432

Options	Price	Required to Specify
Surface Materials <ul style="list-style-type: none"> • High-Pressure Laminate top <ul style="list-style-type: none"> • Laminate price group 2 • Open Line laminate • Wood veneer top <ul style="list-style-type: none"> • Wood veneer • Premium wood 2 • Premium wood 3 • Customiz stain 	<ul style="list-style-type: none"> • See information at left • +\$ 69 plus cost of laminate • Price below • +\$ 69 • +\$242 • No cost 	<ul style="list-style-type: none"> • Specify laminate color number. ▶ See <i>Surface Materials Reference Manual</i>. • Specify wood veneer finish number. • Specify Premium wood 2 finish number. • Specify Premium wood 3 finish number. • Specify <i>with Customiz stain</i>.
Legs <ul style="list-style-type: none"> • Steel legs <ul style="list-style-type: none"> • Paint price group 1 • Paint price group 2 • Paint price group 3 • Wood legs <ul style="list-style-type: none"> • Beech 	<ul style="list-style-type: none"> • No cost • +\$ 52 • +\$110 • +\$700 	<ul style="list-style-type: none"> • Specify paint color number. • Specify paint color number. • Specify paint color number. • Specify wood finish number.
Power <ul style="list-style-type: none"> ▶ Power Matrix, page 326 • No power • With power: center position (two receptacles for power and one receptacle for power/one USB) 	<ul style="list-style-type: none"> • No cost • +\$675 	<ul style="list-style-type: none"> • Specify <i>with no power</i>. • Specify <i>with power</i> and select paint color number.
Related Products <ul style="list-style-type: none"> • Cable riser 		<ul style="list-style-type: none"> ▶ Page 337

Specification Information

Style Number	Base Price

High-Pressure Laminate

N3LPINT	\$2500
---------	--------

Wood Group 1

N3LPINT	\$3300
---------	--------

B-Free Cable Riser

SIN 711.11

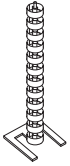

Tip: Cable riser is for use with wood leg tables and attaches to the underside of the tray.

Standard Includes	Required to Specify
-------------------	---------------------

- | | | |
|--|--|---------------------|
| <ul style="list-style-type: none"> ▶ Need help? Product details, page 325 | <ul style="list-style-type: none"> • Cable riser spring 47¼"H: merle only | <p>Style number</p> |
|--|--|---------------------|

Specification Information	
---------------------------	--

• Style Number	• Price
N3LCABLE	\$125
.	.



i2i 416 Series

i2i is collaborative lounge seating that helps people move freely, change postures, and stay energized and comfortable.

Upholstery specified is applied to seat and arms.

Flexing fingers form the back and offer support while moving and conforming to your body.

Dual-swivel mechanism allows the back and seat to swivel independently as well as together.

Four-arm base is standard in polished aluminum.

Glides are standard with the static base.

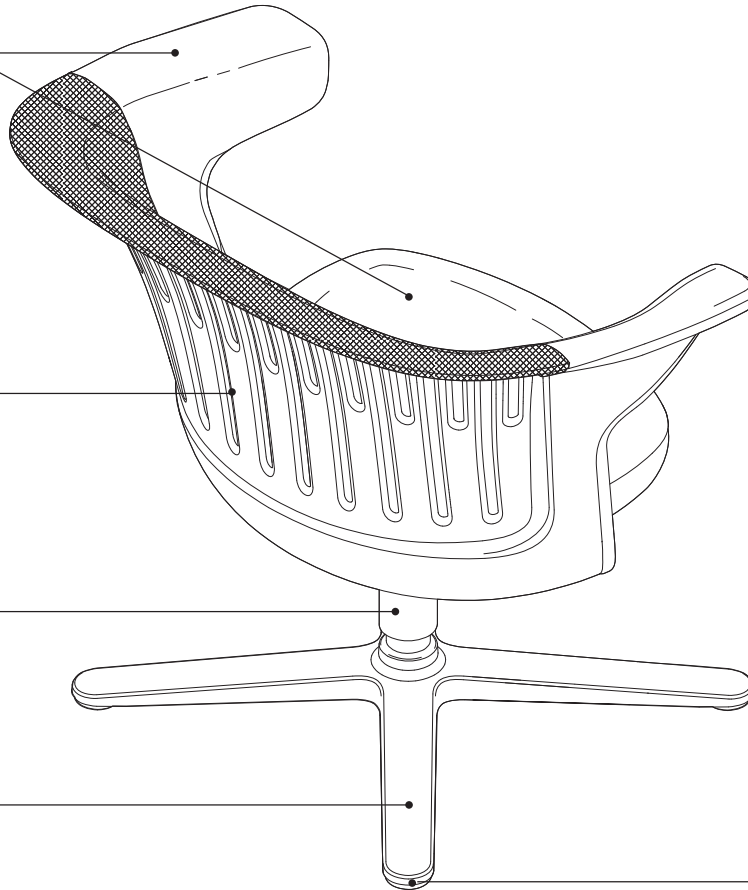

Product Details

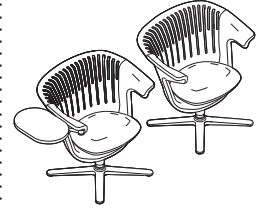

Chairs are available with or without tablet arm.

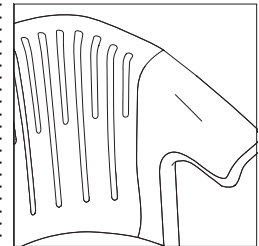

Flexing fingers in the back promote movement and provide support in a variety of postures.

Dual-swivel mechanism allows the back and seat to swivel independently as well as together.

Tablet arm attaches on the right side of the chair with a dual pivot function providing a range of motion that allows the tablet area to accommodate both left and right handed users. It provides a worksurface 12¹/₄"D x 18"W. The tablet ships separately and requires field assembly and installation.

Adjustment Features

Swivel-return cylinder option has a built in memory and will return to the fixed position when the user leaves the chair.

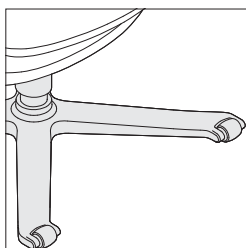

Mobile base includes two rollers on the front arms of the base that allow the chair to be moved easily.

Surface Materials

▶ See surface materials on page 432 for specific availability or refer to the *Surface Materials Reference Manual* for further information.

Back Upholstery

- 3D Knit (back only)

Seat and Arm Upholstery

- Cogent: Connect (seat and arm only)
- Fabric
- Fabric with soil-retardant treatment (option)
- Leather
- Elmosoft leather
- Select Surfaces leather
- Vinyl
- COM
- COL

Cogent: Connect maximizes quality and comfort on i2i. The selected upholstery will be applied to the seat and arms. It is standard with a sewn application.

Frame

- 6009 Arctic White
- 6249 Platinum
- 6295 Near Black

Tablet Arm

- Laminate
- Veneer

The laminate surface is available with a black edge only. The veneer surface has a self edge. The tablet ships separately and requires field assembly and installation.

Glides

- Black plastic

Rollers

- Optional rollers on mobile base are available in dark fusion only.

All Steelcase seating with standard upholstery fabrics

complies with requirements of the State of California Technical Bulletin 117-2013. All standard seating is labeled to be in compliance with California 117-2013.

Programs & Services

▶ See the *Surface Materials Reference Manual* for further detail about programs and services offered for seating.

The Customer's Own Material (COM) Program

offers the opportunity for customers to select fabrics that are not offered through the standard Steelcase surface materials program for use on Steelcase products. Through the COM program, Steelcase will test your materials for application on Steelcase products. Once approved, you can place your order. Steelcase will facilitate the entire ordering process and give you a production schedule. Steelcase will order the COM fabric directly from the textile manufacturer. For up-to-date information regarding fabric test results for all COM fabrics and details regarding yardage requirements for most Seating lines, visit the COM website. To locate the COM website:

- Visit www.steelcase.com

Soil retardants are treatments that provide long-term soil and stain resistance to a fabric without affecting the shade or the integrity of the fabric. The following Steelcase Textiles are available pre-treated with soil retardant. (You do not need to select the soil-retardant option for these fabrics and incur the upcharge.)

- Jacks
- Link
- Spyder

For information on soil retardant fabrics on Select Surfaces, please refer to the *Surface Materials Reference Manual*.

Soil-retardant treatment is available on all other seating fabrics at an additional upcharge per seating unit. To order this option, please select "Soil-Retardant Treatment" under "Optional Accessories."

For soil-retardant treatment on COMs, please select "Soil-Retardant Treatment" under "Optional Accessories." Minimums or additional yardage may be required. Please contact the vendor directly for specific information.

Extended lead times may be necessary for this service.

Contact your Steelcase Solutions Fulfillment Team Representative at 1.888.STEELCASE (1.888.783.3522) or send an email to lineone@steelcase.com.

Dimensions

▶ Page 340

Resources

Printed Materials

▶ i2i Brochure (08-0001013)

Online Resources

▶ Come Together (PDF) available on www.steelcase.com

▶ Collaborative Seating Video available on www.steelcase.com

▶ Environmental profiles available on www.steelcase.com/sustainability

Dimensions

i2i 416 Series

Features	Overall Depth	Width	Height	Seat Depth	Functional Seat Depth	Seat Width	Seat Height from Floor	Back Height from Seat	Back Lumbar Height
i2i 416 Series									
Collaborative Lounge Chairs									
	25"	32½"	31⅛"	17½"	17¼"	19"	17½"	17¼"	9¼"

Dimensions were measured with BIFMA CMD (chair-measuring device).

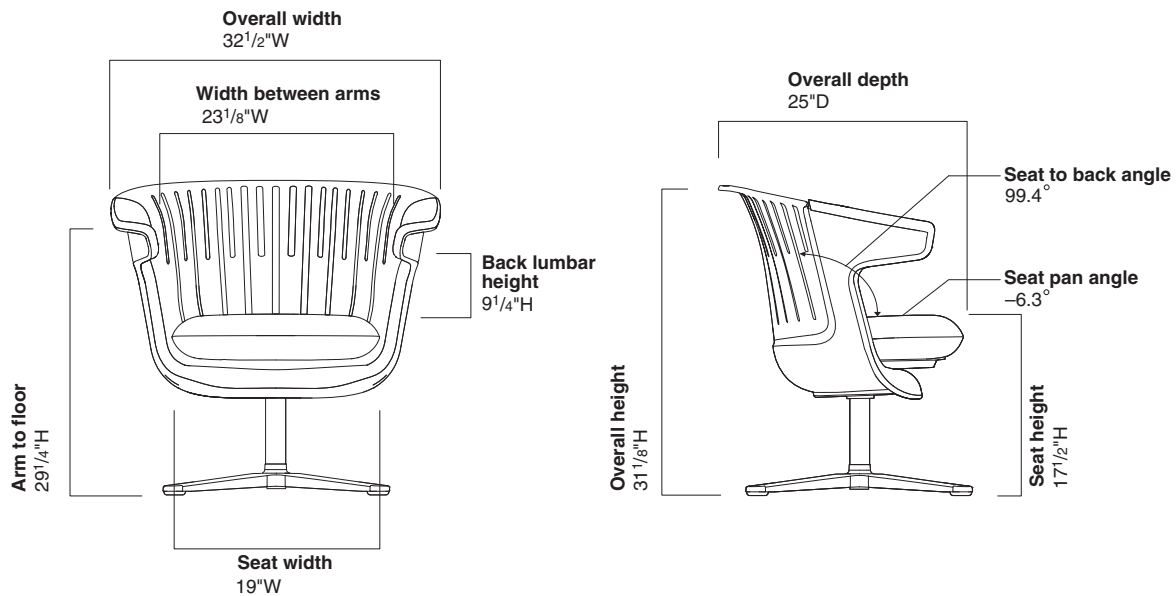

• Width • Between • Arms	• Arm • to • Floor	• Seat • Pan • Angle	• Angle • Between • Seat and • Back
--------------------------------	--------------------------	----------------------------	--

Collaborative Lounge Chairs

23 1/8"	29 1/4"	-6.3°	99.4°
.	.	.	.

i2i 416 Series Collaborative Lounge Chairs

SIN 711.18

Standard Includes		Required to Specify
<ul style="list-style-type: none"> ▶ Need help? Product details, page 338 	<ul style="list-style-type: none"> • Back: near black • Static base with dual-swivel mechanism: polished aluminum • Back upholstery: 3D Knit • Seat and arms: sewn upholstery • Tablet arm, if selected: laminate • Glides: black plastic 	<ol style="list-style-type: none"> 1 Style number 2 Plastic color number for frame 3 3D Knit color number for back 4 Fabric color number for upholstery on seat and arms 5 Laminate color number for tablet arm, if selected 6 Options, if selected (see below) <p>▶ See <i>Surface Materials</i>, page 432.</p>

Tip: Cogent: Connect maximizes quality and comfort on the seat and arms on i2i.

Options	Price	Required to Specify	
Surface Materials	Upholstery		
• Fabric price group 1	No cost	Specify fabric color number.	
• Fabric price group 2	No cost	Specify fabric color number.	
• Fabric price group 3	+\$ 48	Specify fabric color number.	
• Fabric price group 4	+\$ 68	Specify fabric color number.	
• Fabric price group 5	+\$ 85	Specify fabric color number.	
• Fabric price group 6	+\$106	Specify fabric color number.	
• Fabric price group 7	+\$121	Specify fabric color number.	
• Fabric price group 8	+\$153	Specify fabric color number.	
• Fabric price group 9	+\$188	Specify fabric color number.	
• Fabric price group 10	+\$213	Specify fabric color number.	
• Customer's Own Material/ Vinyl (COM-sewn)	+\$ 41	See <i>Surface Materials Reference Manual</i> to specify.	
• Steelcase leather upholstery	+\$353	Specify leather color number.	
• Select Surfaces leather price group 1	+\$353	▶ See <i>Surface Materials Reference Manual</i> .	
• Elmosoft leather	+\$408	Specify Elmosoft leather color number.	
• Select Surfaces leather price group 2	+\$408	▶ See <i>Surface Materials Reference Manual</i> .	
• Steelcase vinyl	No cost	Specify vinyl color number.	
• Customer's Own Leather (COL)	+\$ 41	See <i>Surface Materials Reference Manual</i> to specify.	
Soil-retardant treatment	+\$ 25	Specify with soil-retardant treatment.	
Back shell			
• Arctic white	+\$ 86	Specify with 6009 Arctic White.	
• Platinum	+\$ 86	Specify with 6249 Platinum.	
Base	• Mobile base	+\$ 57	Specify with mobile base.
Cylinder	• Swivel with return	+\$ 57	Specify with swivel return.
Tablet Arm	• Wood veneer group 1	+\$229	Specify wood color number.

Tip: For list of wood veneer options available on tablet arm, please see list on page 432.

Specification Information

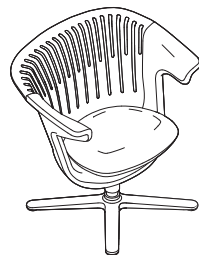

• **Style Number**
416911

• **Base Price**
\$2103

With tablet arm

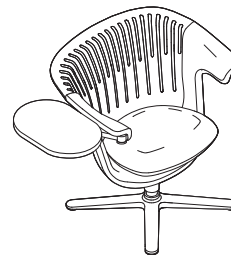

• **Style Number**
416911T

• **Base Price**
\$2337

▶ Detailed dimensions, page 340

Collaborative Lounge Table

SIN 711.11

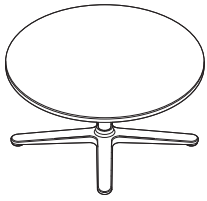

For laminate price group 2 pricing, please refer to the electronic catalog or SmartTools.

Standard Includes	Required to Specify
<ul style="list-style-type: none"> ▶ Need help? See <i>c:scape Specification Guide</i> for details. Table: High-Pressure Laminate price group 1 surface with 3 mm plastic edge profile Base: polished aluminum 	<ol style="list-style-type: none"> 1 Style number 2 Laminate color number for table 3 Plastic color number for edge on laminate surface 4 Options, if selected (see below) <p>▶ See <i>c:scape Specification Guide</i>.</p>

Options	Price	Required to Specify
Surface Materials		
High-Pressure Laminate surface		
<ul style="list-style-type: none"> High-Pressure Laminate price group 2 Open Line laminate 	See information at left +\$ 69 plus cost of laminate	Specify laminate color number. ▶ See <i>Surface Materials Reference Manual</i> .
Wood veneer surface		
<ul style="list-style-type: none"> Wood group 1 with matching 3 mm edge profile Wood group 2 Wood group 3 Customiz stain 	+\$405 +\$433 +\$499 No cost	Specify wood color number. Specify wood color number. Specify wood color number. Specify <i>with Customiz stain</i> . ▶ See <i>Surface Materials Reference Manual</i> . Specify full-fill finish number.
<ul style="list-style-type: none"> Full-fill finish on wood group 1 	+\$ 28	

Specification Information			
Dimensions		Style Number	Base Price
Diameter	Height		
32"	16"	CQCT1632	\$1318

I2i 416 Series

Product on this page is *c:scape*, not seating. It is included here to simplify your planning. Remember that systems has different pricing terms than seating products.

Kart Series

Kart seating collection

offers solutions for classrooms, cafeterias, training rooms, and multipurpose rooms.

Seat height adjusts within a 5" range with a pneumatic adjustment mechanism.

Casters have hard, dual wheels that roll smoothly on carpets. Soft, dual-wheel casters are available as an option for use on hard floors or chair mats.

Tip: Do not roll the chair across asphalt during installation as this may damage the casters.

Arms, glides, and back-seat connection will always be black.

Leg base models are available with arms only.



Flip the seat on the nesting chairs and eight Kart chairs can nest in the space of two and a half.

Tilt tension adjustment allows you to control the amount of resistance needed for reclining.

Four-arm base is standard on nesting chairs.

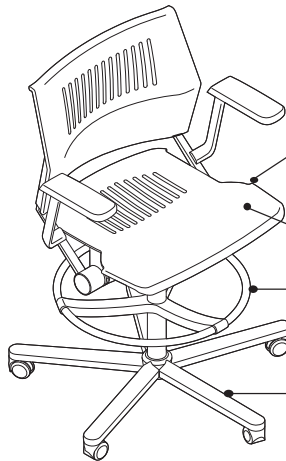

Back lock mechanism allow users to lock the back in an upright position.

Stools do not nest.

Adjustable 19" diameter chrome foot ring

The stool has a five-arm base.

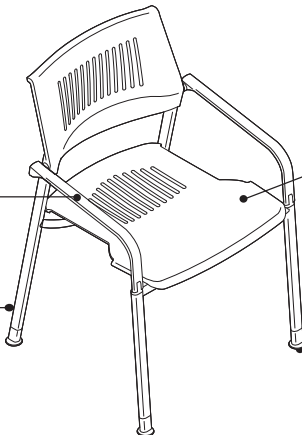

Kart stacking chair stacks six high on the floor.

Glides are standard on stacking chair with the option of hard dual-wheel casters for use on carpets.

Product Details



Nesting chairs and stools with casters are available with or without arms.

Kart is available non-upholstered, upholstered seat only, or upholstered seat and back.

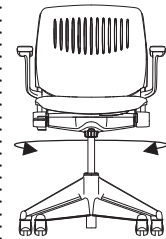

360° swivel motion is locked when in nesting mode (seat up and engaged with base).

Stackability for leg-base models is six high on the floor. Leg-base models with casters are not recommended to stack as damage to arms may occur.

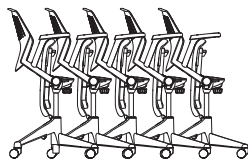

Nesting chairs have the ability to nest eight chairs in the space of two and a half.

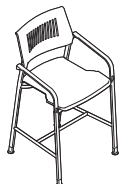

Kart café stools do not stack.

Jury base models are standard with memory return and 180° swivel in black only.

Kart chairs and stools come standard uncartoned. There is an option to have Kart cartoned. Jury base models are available to ship cartoned only.

Adjustment Features

Adjustability instructions are included with every swivel-base chair. Instructions can also be found at www.steelcase.com.

Seat Adjustments

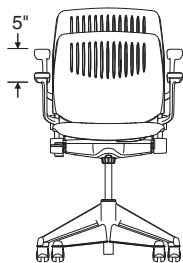

Seat height adjusts pneumatically. To lower, hold handle up while seated. To raise, hold handle up and keep your weight off the chair. Range of adjustability is 5".

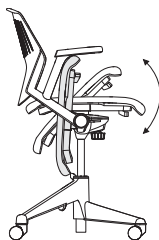

Seat flips on nesting chairs and jury base chairs. Pull the lever under the seat toward the front of the chair and tip the seat up. As the seat releases, the pneumatic lift activates and pushes the chair to its full height position. To lock, spin the chair until the seat engages with the base tooth.



Tilt Tension. To loosen, turn control knob counter-clockwise. To tighten, turn control knob clockwise.

Back Adjustments

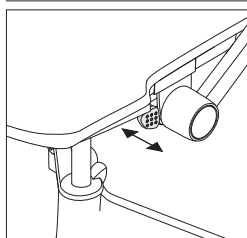

Forward back lock on nesting and stool with casters. Lean forward, pull triangular knob out until it stops.

Foot Ring Adjustments

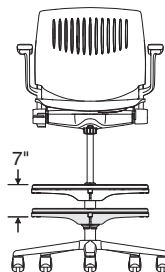

19" chrome foot ring adjusts 8 1/2"H to 15 1/2"H by rotating it left or right.

Other Features

Hard dual-wheel casters for use on soft floors come standard on nesting chairs as well as stools with casters.

Soft dual-wheel casters for hard floors on nesting or five-arm base stools are available for specific applications.

Surface Materials

▶ See surface materials on page 432 for specific availability or refer to the *Surface Materials Reference Manual* for further information.

Fabric and leathers will appear loose with comfort wrinkles when upholstered.

Back frame and seat shell are plastic on all Kart models.

Upholstery

- Fabric
- Leather
- Elmosoft Leather

Hard Components

(Base, back supports, and arm support bar)

- Aluminum with paint

(Rub strips, yoke strips, non-upholstered seat, and back)

- Plastic

(Café stool steel frame)

- Paint

Arm Caps

- Black plastic

Foot Ring

- Chrome

Casters

- Black only

Glides

- Standard on café stool and optional on nesting and stools with casters.

Jury Base

- Black

Extra Foam

- Available on nesting and stools with casters.

Programs & Services

▶ See the *Surface Materials Reference Manual* for further detail about programs and services offered for seating.

The Customer's Own Material (COM) Program

offers the opportunity for customers to select fabrics that are not offered through the standard Steelcase surface materials program for use on Steelcase products. Through the COM program, Steelcase will test your materials for application on Steelcase products.

Once approved, you can place your order. Steelcase will facilitate the entire ordering process and give you a production schedule. Steelcase will order the COM fabric directly from the textile manufacturer. For up-to-date information regarding fabric test results for all COM fabrics and details regarding yardage requirements for most Seating lines, visit the COM website. To locate the COM website:

- Visit www.steelcase.com

Dimensions

▶ Page 346

Resources

Printed Materials

▶ Kart Brochure (16-00000129)

Online Resources

▶ Environmental profiles available on www.steelcase.com/sustainability

Dimensions

Features	Overall Depth	Width	Height	Seat Depth	Seat Width	Seat Height from Floor	Ring Height from Floor	Back Width
----------	---------------	-------	--------	------------	------------	------------------------	------------------------	------------

Kart

Nesting Chairs

With arms	22½"	24½"	38"	17¾"	19"	16" to 21"	N.A.	18"
Without arms	22½"	24½"	38"	17¾"	19"	16" to 21"	N.A.	18"

Stools with Casters

With arms	22½"	24½"	44"	17¾"	19"	21" to 28½"	8½" to 15½"	18"
Without arms	22½"	24½"	44"	17¾"	19"	21" to 28½"	8½" to 15½"	18"

Café Leg-Base Stools

With arms	25"	22¼"	46"	18¼"	19¾"	30"	8½" to 15½"	18"
-----------	-----	------	-----	------	------	-----	-------------	-----

Stacking Leg-Base Chairs

With arms	22¾"	22¼"	32⅞"	18¼"	19¾"	17⅞"	N.A.	18"
-----------	------	------	------	------	------	------	------	-----

Jury Base Chairs

With arms	22½"	24½"	36"	17¾"	19"	16½" to 20½"	N.A.	18"
Without arms	22½"	24½"	36"	17¾"	19"	16½" to 20½"	N.A.	18"
With arms—tall range	22½"	24½"	38"	17¾"	19"	19¼" to 23¼"	N.A.	18"
Without arms—tall range	22½"	24½"	38"	17¾"	19"	19¼" to 23¼"	N.A.	18"

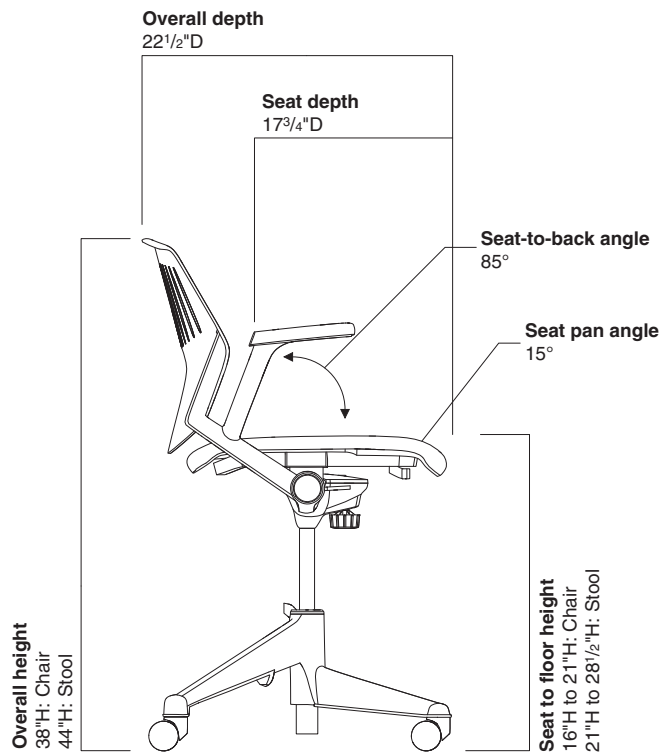
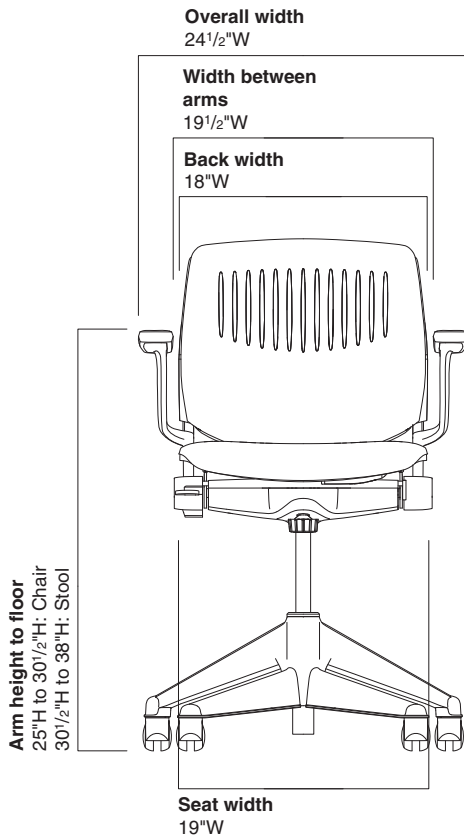

• **Width Between Arms**
 • **Arm Height to Floor**
 • **Angle Between Seat and Back**
 • **Seat Pan Angle**

Nesting Chairs			
19½"	25 to 30½"	85°	15°
N.A.	N.A.	85°	15°
Stools with Casters			
19½"	30½" to 38"	85°	15°
N.A.	N.A.	85°	15°
Café Leg-Base Stools			
19½"	38"	85°	15°
Stacking Leg-Base Chairs			
19½"	26"	85°	15°
Jury Base Chairs			
19½"	25" to 30½"	85°	15°
N.A.	N.A.	85°	15°
19½"	25" to 30½"	85°	15°
N.A.	N.A.	85°	15°

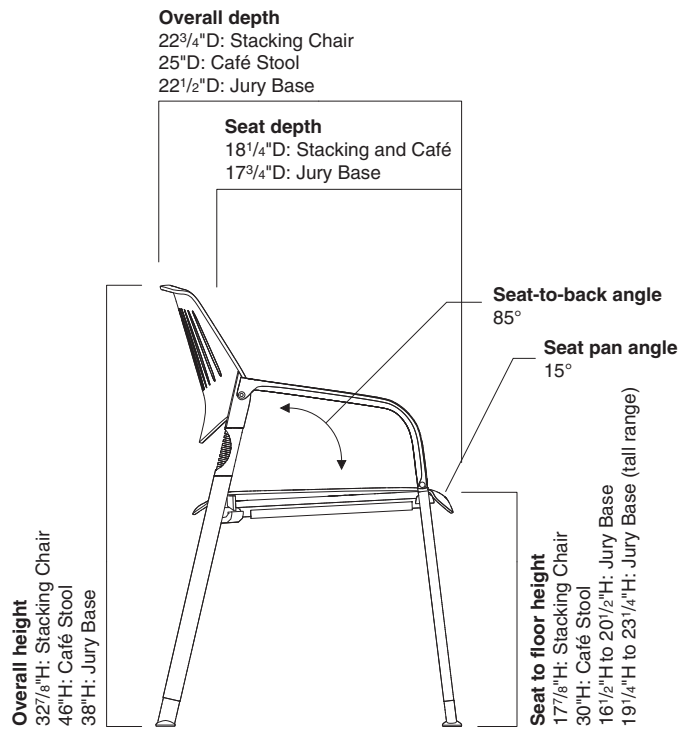
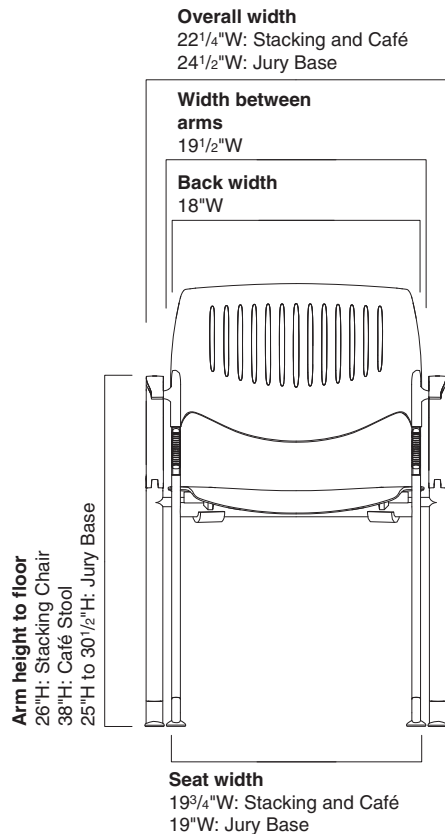

Kart Nesting Chairs

SIN 711.18



Tip: Fabrics and leathers will appear loose with comfort wrinkles when upholstered.

Tip: For Customer's Own Material or Leather, see necessary requirements, important processing instructions, and ordering information.

▶ See *Surface Materials Reference Manual*.

▶ Detailed dimensions, page 346

Standard Includes		Required to Specify
▶ Need help? Product details, page 344	<ul style="list-style-type: none"> • Four-prong Kart nesting base with nylon base tooth: die-cast aluminum with powder coat • Rub strips: injection-molded black polypropylene • Yoke strips: injection-molded black polypropylene • Hard, dual-wheel casters for use on carpet: black plastic • Seat and back: black or gray textured contoured, injection-molded glass-filled Polyurethane • Upholstered seat or upholstered seat and back, if selected: molded urethane foam over injection-molded polypropylene inner shell(s) • Folding seat with self-aligning features • Back supports: one-piece die-cast aluminum • Arms, if selected: die-cast aluminum support bar with black, molded, self-skinning polyurethane arm cap • Pneumatic height adjustment • Tilt tension adjustment • Zero front rise • Forward back lock 	<ol style="list-style-type: none"> 1 Style number 2 Powder coat color number for base 3 Color number for seat and back: <ul style="list-style-type: none"> – 6052 Milk – 6248 Midnight Brown – 6400 Black – 6427 Grey 4 Fabric or leather color number for upholstery, if selected 5 Options, if selected (see below) <ul style="list-style-type: none"> ▶ See <i>Surface Materials</i>, page 432.

Options	Price	Required to Specify
Surface Materials		
Non-upholstered chair		
• Plastic	No cost	Specify plastic color number.
Upholstery on seat and back		
• Fabric price group 1	No cost	Specify fabric color number.
• Fabric price group 2	+\$ 21	Specify fabric color number.
• Fabric price group 3	+\$ 49	Specify fabric color number.
• Fabric price group 4	+\$ 70	Specify fabric color number.
• Fabric price group 5	+\$ 84	Specify fabric color number.
• Fabric price group 6	+\$103	Specify fabric color number.
• Fabric price group 7	+\$123	Specify fabric color number.
• Fabric price group 8	+\$154	Specify fabric color number.
• Fabric price group 9	+\$180	Specify fabric color number.
• Fabric price group 10	+\$217	Specify fabric color number.
• Steelcase leather upholstery	+\$103	Specify leather color number.
• Elmosoft leather upholstery	+\$205	Specify Elmosoft leather color number.
• Customer's Own Material (COM)	+\$ 41	▶ See <i>Surface Materials Reference Manual</i> to specify.
• Customer's Own Leather (COL)	No cost	▶ See <i>Surface Materials Reference Manual</i> to specify.
Contrasting upholstery on seat and back		
• Contrasting fabrics	+\$ 31	Add suffix K to the style number and specify fabric color numbers.
Contrasting upholstery on seat		
• Fabric price group 1	No cost	Specify fabric color number.
• Fabric price group 2	+\$ 10	Specify fabric color number.
• Fabric price group 3	+\$ 24	Specify fabric color number.
• Fabric price group 4	+\$ 35	Specify fabric color number.
• Fabric price group 5	+\$ 42	Specify fabric color number.
• Fabric price group 6	+\$ 51	Specify fabric color number.
• Fabric price group 7	+\$ 61	Specify fabric color number.
• Fabric price group 8	+\$ 77	Specify fabric color number.
• Fabric price group 9	+\$ 90	Specify fabric color number.
• Fabric price group 10	+\$108	Specify fabric color number.
• Steelcase leather upholstery	+\$ 51	Specify leather color number.
• Elmosoft leather upholstery	+\$102	Specify leather color number.
• Customer's Own Material/ Vinyl (COM)	+\$ 20	▶ See <i>Surface Materials Reference Manual</i> to specify.
• Customer's Own Leather (COL)	No cost	▶ See <i>Surface Materials Reference Manual</i> to specify.

▶ Options, continued on next page

SIN 711.18

► Options, continued from previous page

Options	Price	Required to Specify
Surface Materials, continued	Contrasting upholstery on back	
	• Fabric price group 1	No cost
	• Fabric price group 2	+\$ 11
	• Fabric price group 3	+\$ 25
	• Fabric price group 4	+\$ 35
	• Fabric price group 5	+\$ 42
	• Fabric price group 6	+\$ 52
	• Fabric price group 7	+\$ 62
	• Fabric price group 8	+\$ 77
	• Fabric price group 9	+\$ 90
	• Fabric price group 10	+\$109
	• Steelcase leather upholstery	+\$ 52
	• Elmosoft leather upholstery	+\$103
	• Customer's Own Material/ Vinyl (COM)	+\$ 21
	• Customer's Own Leather (COL)	No cost
		Specify fabric color number. Specify fabric color number. Specify fabric color number. Specify fabric color number. Specify fabric color number. Specify fabric color number. Specify fabric color number. Specify fabric color number. Specify fabric color number. Specify fabric color number. Specify leather color number. Specify leather color number. See <i>Surface Materials Reference Manual</i> to specify. See <i>Surface Materials Reference Manual</i> to specify.
Casters	• Soft, dark grey treaded, dual-wheel roll-control casters for use on hard floors	+\$ 41
		Specify with soft roll-control casters.
Extra Foam	• Extra foam	+\$ 70
		Specify with extra foam.
Glide	• Glide	+\$ 35
		Specify with glides.
Related Products	• Jury base • Pouch and leash	
		► Page 360 ► Page 350

Specification Information

Style Number	Base Price
.....

Non-Upholstered with Arms

126A101 \$ 857

Non-Upholstered without Arms

126A100 \$ 782

Upholstered Seat with Arms

126A201S \$1034

Upholstered Seat without Arms

126A200S \$ 959

► Specification Information, continued on next page



Kart Nesting Chairs, continued

SIN 711.18

► Specification Information, continued from previous page

Specification Information

• Style Number	• Base Price
----------------	--------------

Upholstered Seat and Back with Arms

126A201	\$1088
---------	--------

Upholstered Seat and Back without Arms

126A200	\$1013
---------	--------



Pouch and Leash for Use on Kart Nesting Chairs

Standard Includes

- Leash to retain up to 10 nested chairs
- Pouch to store leash
- Pouch attaches to bottom of seat

Required to Specify

Style number

Specification Information

• Style Number	• Price
----------------	---------

126900	\$70
--------	------

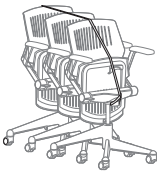

Kart Stools

with Casters

SIN 711.18



Tip: Stools do not nest.

Tip: Fabrics and leathers will appear loose with comfort wrinkles when upholstered.

Tip: For Customer's Own Material or Leather, see necessary requirements, important processing instructions, and ordering information.

► See *Surface Materials Reference Manual*.

► Detailed dimensions, page 346

Standard Includes		Required to Specify
► Need help? Product details, page 344	<ul style="list-style-type: none"> • Five-prong base with 25" span: one-piece die-cast aluminum with powder coat color • Telescoping hub cover: black plastic • Adjustable 19" diameter chrome foot ring • Hard, dual-wheel casters for use on carpet: black • Seat and back: black or gray textured contoured, injection-molded glass-filled polypropylene • Upholstered seat or upholstered seat and back, if selected: molded urethane foam over injection-molded polypropylene inner shell(s) • Back supports: one-piece die-cast aluminum • Arms, if selected: die-cast aluminum support bar with black, molded, self-skinning polyurethane arm cap • Pneumatic height adjustment • Tilt tension adjustment • Zero front rise • Forward back lock 	<ol style="list-style-type: none"> 1 Style number 2 Powder coat color number for base 3 Color number for seat and back: <ul style="list-style-type: none"> – 6052 Milk – 6248 Midnight Brown – 6400 Black – 6427 Grey 4 Fabric or leather color number for upholstery, if selected 5 Options, if selected (see below) <ul style="list-style-type: none"> ► See <i>Surface Materials</i>, page 432.

Options	Price	Required to Specify
Surface Materials		
Non-upholstered chair		
• Plastic	No cost	Specify plastic color number.
Upholstery on seat and back		
• Fabric price group 1	No cost	Specify fabric color number.
• Fabric price group 2	+\$ 21	Specify fabric color number.
• Fabric price group 3	+\$ 49	Specify fabric color number.
• Fabric price group 4	+\$ 70	Specify fabric color number.
• Fabric price group 5	+\$ 84	Specify fabric color number.
• Fabric price group 6	+\$103	Specify fabric color number.
• Fabric price group 7	+\$123	Specify fabric color number.
• Fabric price group 8	+\$154	Specify fabric color number.
• Fabric price group 9	+\$180	Specify fabric color number.
• Fabric price group 10	+\$217	Specify fabric color number.
• Steelcase leather upholstery	+\$103	Specify leather color number.
• Elmosoft leather upholstery	+\$205	Specify Elmosoft leather color number.
• Customer's Own Material (COM)	+\$ 41	► See <i>Surface Materials Reference Manual</i> to specify.
• Customer's Own Leather (COL)	No cost	► See <i>Surface Materials Reference Manual</i> to specify.
Contrasting upholstery on seat and back		
• Contrasting fabrics	+\$ 31	Add suffix K to the style number and specify fabric color numbers.
Contrasting upholstery on seat		
• Fabric price group 1	No cost	Specify fabric color number.
• Fabric price group 2	+\$ 10	Specify fabric color number.
• Fabric price group 3	+\$ 24	Specify fabric color number.
• Fabric price group 4	+\$ 35	Specify fabric color number.
• Fabric price group 5	+\$ 42	Specify fabric color number.
• Fabric price group 6	+\$ 51	Specify fabric color number.
• Fabric price group 7	+\$ 61	Specify fabric color number.
• Fabric price group 8	+\$ 77	Specify fabric color number.
• Fabric price group 9	+\$ 90	Specify fabric color number.
• Fabric price group 10	+\$108	Specify fabric color number.
• Steelcase leather upholstery	+\$ 51	Specify leather color number.
• Elmosoft leather upholstery	+\$102	Specify leather color number.
• Customer's Own Material/ Vinyl (COM)	+\$ 20	► See <i>Surface Materials Reference Manual</i> to specify.
• Customer's Own Leather (COL)	No cost	► See <i>Surface Materials Reference Manual</i> to specify.

► Options, continued on next page

SIN 711.18

► Options, continued from previous page

Options	Price	Required to Specify
Surface Materials, continued	Contrasting upholstery on back	
	• Fabric price group 1	No cost
	• Fabric price group 2	+\$ 11
	• Fabric price group 3	+\$ 25
	• Fabric price group 4	+\$ 35
	• Fabric price group 5	+\$ 42
	• Fabric price group 6	+\$ 52
	• Fabric price group 7	+\$ 62
	• Fabric price group 8	+\$ 77
	• Fabric price group 9	+\$ 90
	• Fabric price group 10	+\$109
	• Steelcase leather upholstery	+\$ 52
	• Elmosoft leather upholstery	+\$103
	• Customer's Own Material/ Vinyl (COM)	+\$ 21
	• Customer's Own Leather (COL)	No cost
		Specify fabric color number. Specify fabric color number. Specify fabric color number. Specify fabric color number. Specify fabric color number. Specify fabric color number. Specify fabric color number. Specify fabric color number. Specify fabric color number. Specify fabric color number. Specify leather color number. See <i>Surface Materials Reference Manual</i> to specify. See <i>Surface Materials Reference Manual</i> to specify.
Casters	• Soft, dark grey treaded, dual-wheel roll-control casters for use on hard floors	+\$ 41
		Specify with soft roll-control casters.
Extra Foam	• Extra foam	+\$ 70
		Specify with extra foam.
Glide	• Glide	+\$ 35
		Specify with glides.

Specification Information

Style Number	Base Price

Non-Upholstered with Arms

126B101ST	\$1011

Non-Upholstered without Arms

126B100ST	\$ 936

Upholstered Seat with Arms

126B201SST	\$1188

► Specification Information, continued on next page



Kart Stools, with Casters, continued

SIN 711.18

► Specification Information, continued from previous page

Specification Information

• Style Number	• Base Price
-------------------	-----------------

Upholstered Seat without Arms

126B200SST	\$1113
-------------------	--------



Upholstered Seat and Back with Arms

126B201ST	\$1242
------------------	--------



Upholstered Seat and Back without Arms

126B200ST	\$1167
------------------	--------



Kart Café Leg-Base Stools

With Arms

SIN 711.18



Tip: Stools do not stack.

Tip: Fabrics and leathers will appear loose with comfort wrinkles when upholstered.

Tip: For Customer's Own Material or Leather, see necessary requirements, important processing instructions, and ordering information.

▶ See *Surface Materials Reference Manual*.

Tip: Arms, glides, and back-seat connection will always be black.

Standard Includes	Required to Specify
<ul style="list-style-type: none"> ▶ Need help? Product details, page 344 • Frame: 16-gauge tubular steel with powder coat color • Flex bars: two black resilient polypropylene flexible connectors in the back frame allow the back to tilt back approximately eight degrees for added comfort • Glides: non-marring, black polypropylene • Seat and back: black textured contoured, injection-molded glass-filled, high-impact polypropylene • Upholstered seat or upholstered seat and back, if selected: resilient, flame-retardant, molded urethane foam over injection-molded polypropylene inner shell(s) 	<ol style="list-style-type: none"> 1 Style number 2 Powder coat color number for base 3 Color number for seat and back: <ul style="list-style-type: none"> – 6052 Milk – 6248 Midnight Brown – 6400 Black 4 Fabric or leather color number for upholstery, if selected 5 Options, if selected (see below) <p>▶ See <i>Surface Materials</i>, page 432.</p>

Surface Materials	Options	Price	Required to Specify
	Non-upholstered chair		
	• Plastic	No cost	Specify plastic color number.
	Upholstery on seat and back		
	• Fabric price group 1	No cost	Specify fabric color number.
	• Fabric price group 2	+\$ 21	Specify fabric color number.
	• Fabric price group 3	+\$ 49	Specify fabric color number.
	• Fabric price group 4	+\$ 70	Specify fabric color number.
	• Fabric price group 5	+\$ 84	Specify fabric color number.
	• Fabric price group 6	+\$103	Specify fabric color number.
	• Fabric price group 7	+\$123	Specify fabric color number.
• Fabric price group 8	+\$154	Specify fabric color number.	
• Fabric price group 9	+\$180	Specify fabric color number.	
• Fabric price group 10	+\$217	Specify fabric color number.	
• Steelcase leather upholstery	+\$103	Specify leather color number.	
• Elmosoft leather upholstery	+\$205	Specify Elmosoft leather color number.	
• Customer's Own Material (COM)	+\$ 41	▶ See <i>Surface Materials Reference Manual</i> to specify.	
• Customer's Own Leather (COL)	No cost	▶ See <i>Surface Materials Reference Manual</i> to specify.	
Contrasting upholstery on seat and back			
• Contrasting fabrics	+\$ 31		Add suffix K to the style number and specify fabric color numbers.
Contrasting upholstery on seat			
• Fabric price group 1	No cost		Specify fabric color number.
• Fabric price group 2	+\$ 10		Specify fabric color number.
• Fabric price group 3	+\$ 24		Specify fabric color number.
• Fabric price group 4	+\$ 35		Specify fabric color number.
• Fabric price group 5	+\$ 42		Specify fabric color number.
• Fabric price group 6	+\$ 51		Specify fabric color number.
• Fabric price group 7	+\$ 61		Specify fabric color number.
• Fabric price group 8	+\$ 77		Specify fabric color number.
• Fabric price group 9	+\$ 90		Specify fabric color number.
• Fabric price group 10	+\$108		Specify fabric color number.
• Steelcase leather upholstery	+\$ 51		Specify leather color number.
• Elmosoft leather upholstery	+\$102		Specify leather color number.
• Customer's Own Material/ Vinyl (COM)	+\$ 20		▶ See <i>Surface Materials Reference Manual</i> to specify.
• Customer's Own Leather (COL)	No cost		▶ See <i>Surface Materials Reference Manual</i> to specify.

▶ Options, continued on next page

▶ Detailed dimensions, page 346

SIN 711.18

► Options, continued from previous page

Options	Price	Required to Specify
Surface Materials, continued	Contrasting upholstery on back	
	• Fabric price group 1	No cost
	• Fabric price group 2	+\$ 11
	• Fabric price group 3	+\$ 25
	• Fabric price group 4	+\$ 35
	• Fabric price group 5	+\$ 42
	• Fabric price group 6	+\$ 52
	• Fabric price group 7	+\$ 62
	• Fabric price group 8	+\$ 77
	• Fabric price group 9	+\$ 90
	• Fabric price group 10	+\$109
	• Steelcase leather upholstery	+\$ 52
	• Elmosoft leather upholstery	+\$103
	• Customer's Own Material/ Vinyl (COM)	+\$ 21
	• Customer's Own Leather (COL)	No cost
		Specify fabric color number.
		Specify fabric color number.
		Specify fabric color number.
		Specify fabric color number.
		Specify fabric color number.
		Specify fabric color number.
		Specify fabric color number.
		Specify fabric color number.
		Specify leather color number.
		Specify leather color number.
		See <i>Surface Materials Reference Manual</i> to specify.
		See <i>Surface Materials Reference Manual</i> to specify.

Specification Information

Style Number	Base Price

Non-Upholstered

126B111ST \$637



Upholstered Seat

126B211SST \$799



Upholstered Seat and Back

126B211ST \$888



Kart Leg-Base Stacking Chairs

With Arms

SIN 711.18



Tip: Chairs stack six high on the floor.

Tip: Fabrics and leathers will appear loose with comfort wrinkles when upholstered.

Tip: For Customer's Own Material or Leather, see necessary requirements, important processing instructions, and ordering information.

▶ See *Surface Materials Reference Manual*.

Tip: Arms, glides, and back-seat connection will always be black.

Standard Includes	Required to Specify
<ul style="list-style-type: none"> ▶ Need help? Product details, page 344 • Frame: 16-gauge tubular steel with powder coat color • Flex bars: two black resilient polypropylene flexible connectors in the back frame allow the back to tilt back approximately eight degrees for added comfort • Glides: non-marring, black polypropylene • Seat and back: black textured contoured, injection-molded glass-filled, high-impact polypropylene • Upholstered seat or upholstered seat and back, if selected: resilient, flame-retardant, molded urethane foam over injection-molded polypropylene inner shell(s) 	<ol style="list-style-type: none"> 1 Style number 2 Powder coat color number for base 3 Color number for seat and back: <ul style="list-style-type: none"> – 6052 Milk – 6248 Midnight Brown – 6400 Black 4 Fabric or leather color number for upholstery, if selected. 5 Options, if selected (see below) <p>▶ See <i>Surface Materials</i>, page 432.</p>

Surface Materials	Options	Price	Required to Specify
	Non-upholstered chair		
	• Plastic	No cost	Specify plastic color number.
	Upholstery on seat and back		
	• Fabric price group 1	No cost	Specify fabric color number.
	• Fabric price group 2	+\$ 21	Specify fabric color number.
	• Fabric price group 3	+\$ 49	Specify fabric color number.
	• Fabric price group 4	+\$ 70	Specify fabric color number.
	• Fabric price group 5	+\$ 84	Specify fabric color number.
	• Fabric price group 6	+\$103	Specify fabric color number.
	• Fabric price group 7	+\$123	Specify fabric color number.
• Fabric price group 8	+\$154	Specify fabric color number.	
• Fabric price group 9	+\$180	Specify fabric color number.	
• Fabric price group 10	+\$217	Specify fabric color number.	
• Steelcase leather upholstery	+\$103	Specify leather color number.	
• Elmosoft leather upholstery	+\$205	Specify Elmosoft leather color number.	
• Customer's Own Material (COM)	+\$ 41	▶ See <i>Surface Materials Reference Manual</i> to specify.	
• Customer's Own Leather (COL)	No cost	▶ See <i>Surface Materials Reference Manual</i> to specify.	
Contrasting upholstery on seat and back			
• Contrasting fabrics	+\$ 31		Add suffix K to the style number and specify fabric color numbers.
Contrasting upholstery on seat			
• Fabric price group 1	No cost		Specify fabric color number.
• Fabric price group 2	+\$ 10		Specify fabric color number.
• Fabric price group 3	+\$ 24		Specify fabric color number.
• Fabric price group 4	+\$ 35		Specify fabric color number.
• Fabric price group 5	+\$ 42		Specify fabric color number.
• Fabric price group 6	+\$ 51		Specify fabric color number.
• Fabric price group 7	+\$ 61		Specify fabric color number.
• Fabric price group 8	+\$ 77		Specify fabric color number.
• Fabric price group 9	+\$ 90		Specify fabric color number.
• Fabric price group 10	+\$108		Specify fabric color number.
• Steelcase leather upholstery	+\$ 51		Specify leather color number.
• Elmosoft leather upholstery	+\$102		Specify leather color number.
• Customer's Own Material/ Vinyl (COM)	+\$ 20		▶ See <i>Surface Materials Reference Manual</i> to specify.
• Customer's Own Leather (COL)	No cost		▶ See <i>Surface Materials Reference Manual</i> to specify.

▶ Options, continued on next page

▶ Detailed dimensions, page 346

► Options, continued from previous page

Options	Price	Required to Specify
Surface Materials, continued	Contrasting upholstery on back	
• Fabric price group 1	No cost	Specify fabric color number.
• Fabric price group 2	+\$ 11	Specify fabric color number.
• Fabric price group 3	+\$ 25	Specify fabric color number.
• Fabric price group 4	+\$ 35	Specify fabric color number.
• Fabric price group 5	+\$ 42	Specify fabric color number.
• Fabric price group 6	+\$ 52	Specify fabric color number.
• Fabric price group 7	+\$ 62	Specify fabric color number.
• Fabric price group 8	+\$ 77	Specify fabric color number.
• Fabric price group 9	+\$ 90	Specify fabric color number.
• Fabric price group 10	+\$109	Specify fabric color number.
• Steelcase leather upholstery	+\$ 52	Specify leather color number.
• Elmosoft leather upholstery	+\$103	Specify leather color number.
• Customer's Own Material/ Vinyl (COM)	+\$ 21	See <i>Surface Materials Reference Manual</i> to specify.
• Customer's Own Leather (COL)	No cost	See <i>Surface Materials Reference Manual</i> to specify.
Casters	• Hard, dual-wheel casters for use on carpet	No cost Add suffix C to the style number.

Specification Information

Style Number	Base Price
.....

Non-Upholstered Seat and Back

126A111	\$445
.....



Upholstered Seat

126A211S	\$688
.....



Upholstered Seat and Back

126A211	\$782
.....



Kart Jury Base Chairs

SIN 711.18



Tip: Standard seat height range: 16½"H–20½"H.

Tip: Tall seat height range: 19¼"H–23¼"H.

Tip: Kart seat folds up.

Tip: Fabrics and leathers will appear loose with comfort wrinkles when upholstered.

Tip: For Customer's Own Material or Leather, see necessary requirements, important processing instructions, and ordering information.

► See *Surface Materials Reference Manual*.

Tip: Jury bases are standard with pneumatic swivel-tilt return mechanism.

► Detailed dimensions, page 346

Standard Includes	Required to Specify
<ul style="list-style-type: none"> ► Need help? Product details, page 344 Jury base with memory return and 180 degree swivel Standard jury base, if selected, is made up of 2½"-diameter column and 8" base plate: 4134 black only Tall jury base, if selected, is made up of 2½"-diameter column and 8" base plate: 4134 black only Seat and back: black textured contoured, injection molded glass-filled, high-impact polypropylene Upholstered seat or upholstered seat and back, if selected: resilient, flame-retardant, molded urethane foam over injection-molded polypropylene inner shell(s) Folding seat with self-aligning features Arms, if selected; die-cast aluminum support bar with black, molded, self-skinning polyurethane arm cap Pneumatic height adjustment Hardware for floor attachment, not included 	<ol style="list-style-type: none"> Style number Powder coat color number for base Color number for seat and back: <ul style="list-style-type: none"> – 6052 Milk – 6248 Midnight Brown – 6400 Black – 6427 Grey Fabric or leather color number for upholstery, if selected Options, if selected (see below) <ul style="list-style-type: none"> ► See <i>Surface Materials</i>, page 432.

Surface Materials	Options	Price	Required to Specify
	Non-upholstered chair		
	• Plastic	No cost	Specify plastic color number.
	Upholstery on seat and back		
	• Fabric price group 1	No cost	Specify fabric color number.
	• Fabric price group 2	+\$ 21	Specify fabric color number.
	• Fabric price group 3	+\$ 49	Specify fabric color number.
	• Fabric price group 4	+\$ 70	Specify fabric color number.
	• Fabric price group 5	+\$ 84	Specify fabric color number.
	• Fabric price group 6	+\$103	Specify fabric color number.
	• Fabric price group 7	+\$123	Specify fabric color number.
• Fabric price group 8	+\$154	Specify fabric color number.	
• Fabric price group 9	+\$180	Specify fabric color number.	
• Fabric price group 10	+\$217	Specify fabric color number.	
• Steelcase leather upholstery	+\$103	Specify leather color number.	
• Elmosoft leather upholstery	+\$205	Specify Elmosoft leather color number.	
• Customer's Own Material (COM)	+\$ 41	► See <i>Surface Materials Reference Manual</i> to specify.	
• Customer's Own Leather (COL)	No cost	► See <i>Surface Materials Reference Manual</i> to specify.	
Contrasting upholstery on seat and back			
• Contrasting fabrics	+\$ 31		Add suffix K to the style number and specify fabric color numbers.
Contrasting upholstery on seat			
• Fabric price group 1	No cost		Specify fabric color number.
• Fabric price group 2	+\$ 10		Specify fabric color number.
• Fabric price group 3	+\$ 24		Specify fabric color number.
• Fabric price group 4	+\$ 35		Specify fabric color number.
• Fabric price group 5	+\$ 42		Specify fabric color number.
• Fabric price group 6	+\$ 51		Specify fabric color number.
• Fabric price group 7	+\$ 61		Specify fabric color number.
• Fabric price group 8	+\$ 77		Specify fabric color number.
• Fabric price group 9	+\$ 90		Specify fabric color number.
• Fabric price group 10	+\$108		Specify fabric color number.
• Steelcase leather upholstery	+\$ 51		Specify leather color number.
• Elmosoft leather upholstery	+\$102		Specify leather color number.
• Customer's Own Material/ Vinyl (COM)	+\$ 20		► See <i>Surface Materials Reference Manual</i> to specify.
• Customer's Own Leather (COL)	No cost		► See <i>Surface Materials Reference Manual</i> to specify.

► Options, continued on next page

SIN 711.18

► Options, continued from previous page

Options	Price	Required to Specify
Surface Materials, continued	Contrasting upholstery on back	
• Fabric price group 1	No cost	Specify fabric color number.
• Fabric price group 2	+\$ 11	Specify fabric color number.
• Fabric price group 3	+\$ 25	Specify fabric color number.
• Fabric price group 4	+\$ 35	Specify fabric color number.
• Fabric price group 5	+\$ 42	Specify fabric color number.
• Fabric price group 6	+\$ 52	Specify fabric color number.
• Fabric price group 7	+\$ 62	Specify fabric color number.
• Fabric price group 8	+\$ 77	Specify fabric color number.
• Fabric price group 9	+\$ 90	Specify fabric color number.
• Fabric price group 10	+\$109	Specify fabric color number.
• Steelcase leather upholstery	+\$ 52	Specify leather color number.
• Elmosoft leather upholstery	+\$103	Specify leather color number.
• Customer's Own Material/ Vinyl (COM)	+\$ 21	See <i>Surface Materials Reference Manual</i> to specify.
• Customer's Own Leather (COL)	No cost	See <i>Surface Materials Reference Manual</i> to specify.
Extra Foam	• Extra foam	+\$ 70
		Specify with extra foam.

Specification Information

Style Number	Base Price

Non-Upholstered with Arms

127C101J	\$1106
----------	--------



Non-Upholstered without Arms

127C100J	\$1031
----------	--------



Upholstered Seat with Arms

127C201SJ	\$1283
-----------	--------



► Specification Information, continued on next page

SIN 711.18

► Specification Information, continued from previous page

Specification Information

• Style Number	• Base Price
----------------	--------------

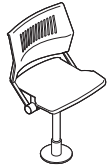

Upholstered Seat without Arms

127C200SJ	\$1208
-----------	--------



Upholstered Seat and Back with Arms

127C201J	\$1337
----------	--------

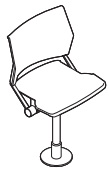

Upholstered Seat and Back without Arms

127C200J	\$1262
----------	--------



Non-Upholstered with Arms – Tall

128C101J	\$1106
----------	--------



Non-Upholstered without Arms – Tall

128C100J	\$1031
----------	--------



Upholstered Seat with Arms – Tall

128C201SJ	\$1283
-----------	--------

► Specification Information, continued on next page

SIN 711.18

► Specification Information, continued from previous page

Specification Information

• Style Number	• Base Price
----------------	--------------

Upholstered Seat without Arms – Tall

128C200SJ	\$1208
------------------	--------

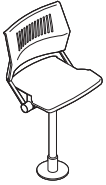

Upholstered Seat and Back with Arms – Tall

128C201J	\$1337
-----------------	--------



Upholstered Seat and Back without Arms – Tall

128C200J	\$1262
-----------------	--------

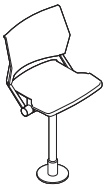

Player 475 Series

Player chairs are guest chairs that also stack. Strength features in the back, arms, and back legs make Player a logical choice for high-traffic areas, and its simple, classic design complements a broad range of work settings.

Back and seat, including outer back, are fully upholstered. High-back and thick-seat options are available.

Arms slope downward and will easily clear the front edge of a worksurface or table. Arms are available in smooth or textured finish.

Steel frame is monochromatic.

Plastic glides with a stainless steel insert are standard.

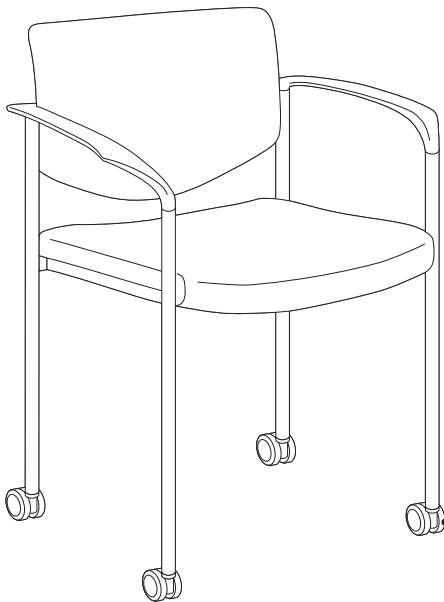
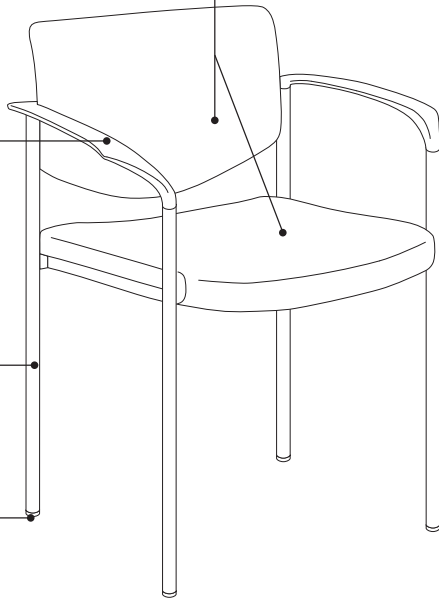

Casters have hard, dual wheels that roll smoothly on carpets. They are 2" in diameter for increased mobility. Soft, dual-wheel casters are available for use on hard floor or chair mats. Casters available in black only.
Tip: Do not roll the chair across asphalt during installation as this may damage the casters.

Product Details

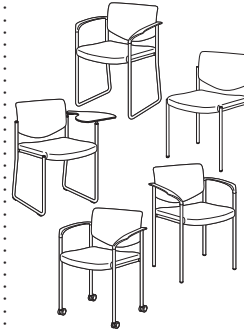

Chair models are available with a leg-base or a sled-base. Stools are available with a leg-base. The leg base arms are available with casters. Chairs and stools are available with several features such as arms, tablet arms, high back, and thick seat.

Stackability for leg-base models is six high on the floor and eight high on the transport and storage dolly. Leg-base models with casters are not recommended to stack as damage to arms may occur. Sled-base models, stools, and chairs with tablet arms will not stack.

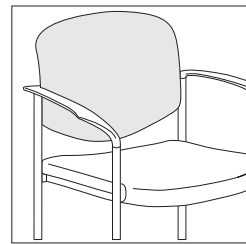

High-back option, available on all Player chairs and stools, adds 2 1/2" to back height. Top edge is slightly rounded. Stackability is not affected.

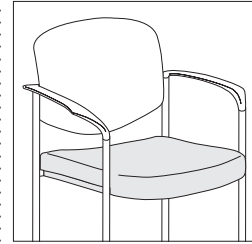

Thick-seat option, available on all Player chairs and stools, increases the thickness of the seat cushion by approximately 1/2". Stackability is not affected.

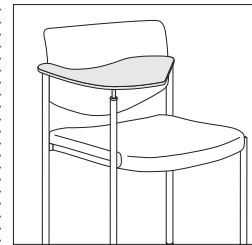

Tablet arm is available right hand and left hand and is shipped knocked down (K.D.). Tablet arm tilts for easy entrance and exit from chair. Tablet arm measures 25 1/2" x 13 1/2". Tablet arm is not available to order separately for installation on existing chairs.

Plastic glides, with stainless steel inserts on leg-base Player chairs, are recommended for carpeted surfaces only.

Soft felt glides are available on Player chairs for non-carpeted surfaces.

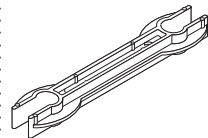

Alignment device is available to temporarily link chairs together for evenly spaced rows. Chairs can be unlinked easily. Spacing between chairs linked with alignment device is 5 7/8".

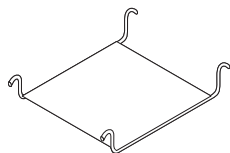

Ganging device is available to link chairs on a more permanent basis. It attaches to the chair's side frame. Spacing between chairs linked with the ganging device is approximately 9".

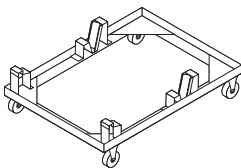

Transport and storage dolly is available to stack, move, and store up to eight chairs with or without arms. Without the dolly, chairs will stack up to six high. Sled-base models, stools, and chairs with tablet arms will not stack.

Fully loaded transport dolly measures 32 $\frac{3}{4}$ "D x 21"W x 55 $\frac{3}{4}$ "H.

Surface Materials

► See surface materials on page 432 for specific availability or refer to the *Surface Materials Reference Manual* for further information.

Upholstery

- Fabric
- Fabric with soil-retardant treatment (option)
- Vinyl

Hard components (arms, frames, and sled base)

- Monochromatic color from list of seating plastic color numbers can be applied to all hard components.

Arms

- Smooth plastic
- Textured plastic

Tablet arms

- Laminate

Casters

- Black only

Glides

- Plastic with stainless steel inserts

All Steelcase seating with standard upholstery fabrics

complies with requirements of the State of California Technical Bulletin 117-2013. All standard seating is labeled to be in compliance with California 117-2013.

Programs & Services

► See the *Surface Materials Reference Manual* for further detail about programs and services offered for seating.

The Customer's Own Material (COM) Program

offers the opportunity for customers to select fabrics that are not offered through the standard Steelcase surface materials program for use on Steelcase products. Through the COM program, Steelcase will test your materials for application on Steelcase products. Once approved, you can place your order. Steelcase will facilitate the entire ordering process and give you a production schedule. Steelcase will order the COM fabric directly from the textile manufacturer. For up-to-date information regarding fabric test results for all COM fabrics and details regarding yardage requirements for most Seating lines, visit the COM website. To locate the COM website:

- Visit www.steelcase.com

Soil retardants are treatments that provide long-term soil and stain resistance to a fabric without affecting the shade or the integrity of the fabric. The following Steelcase Textiles are available pre-treated with soil retardant. (You do not need to select the soil-retardant option for these fabrics and incur the upcharge.)

- Jacks
- Link
- Spyder

For information on soil retardant fabrics on Select Surfaces, please refer to the *Surface Materials Reference Manual*.

Soil-retardant treatment is available on all other seating fabrics at an additional upcharge. To order this option, please select "Soil-Retardant Treatment" under "Optional Accessories."

For soil-retardant treatment on COMs, please select "Soil-Retardant Treatment" under "Optional Accessories." Minimums or additional yardage may be required. Please contact the vendor directly for specific information.

Extended lead times may be necessary for this service.

Contact your Steelcase Solutions Fulfillment Team Representative or contact Line 1 at 1.888.STEELCASE (1.888.783.3522) or send an email to lineone@steelcase.com.

Dimensions

► Page 366

Resources

Printed Materials

► Player Brochure (08-0001468)

Online Resources

► Environmental Profile available at www.steelcase.com/sustainability

Dimensions

Player 475 Series

Features	Overall Depth	Width	Height	Seat Depth	Functional Seat Depth	Seat Width	Seat Height from Floor	Back Width	Back Height from Seat
Player 475 Series									
Leg-Base Chair with Arms									
	21 ¹ / ₄ "	23 ⁷ / ₈ "	30 ¹ / ₄ "	19 ³ / ₄ "	17 ¹ / ₂ "	18 ¹ / ₄ "	18 ¹ / ₄ "	18 ¹ / ₂ "	13 ³ / ₄ "
Leg-Base Chair without Arms									
	21 ¹ / ₄ "	20"	30 ¹ / ₄ "	19 ³ / ₄ "	17 ¹ / ₂ "	18 ¹ / ₄ "	18 ¹ / ₄ "	18 ¹ / ₂ "	13 ³ / ₄ "
Sled-Base Chair with Arms									
	21 ¹ / ₄ "	23 ⁷ / ₈ "	30 ¹ / ₄ "	19 ³ / ₄ "	17 ¹ / ₂ "	18 ¹ / ₄ "	18"	18 ¹ / ₂ "	13 ³ / ₄ "
Sled-Base Chair without Arms									
	21 ¹ / ₄ "	20"	30 ¹ / ₄ "	19 ³ / ₄ "	17 ¹ / ₂ "	18 ¹ / ₄ "	18"	18 ¹ / ₂ "	13 ³ / ₄ "
Leg-Base Stool with Arms									
	21 ¹ / ₄ "	23 ⁷ / ₈ "	42"	19 ³ / ₄ "	17 ¹ / ₂ "	18 ¹ / ₄ "	29 ¹ / ₂ "	18 ¹ / ₂ "	13 ³ / ₄ "
Leg-Base Stool without Arms									
	21 ¹ / ₄ "	20"	42"	19 ³ / ₄ "	17 ¹ / ₂ "	18 ¹ / ₄ "	29 ¹ / ₂ "	18 ¹ / ₂ "	13 ³ / ₄ "

• Back • Lumbar • Height	• Width • Between • Arms	• Arm • to • Floor	• Arm • Height • from • Seat	• Seat • Pan • Angle	• Angle • Between • Seat and • Back
--------------------------------	--------------------------------	--------------------------	---------------------------------------	----------------------------	--

Leg-Base Chair with Arms

7¼"	20½"	25¼"	8¾"	4°	95°
-----	------	------	-----	----	-----

Leg-Base Chair without Arms

7¼"	N.A.	N.A.	N.A.	4°	95°
-----	------	------	------	----	-----

Sled-Base Chair with Arms

7¼"	20½"	25¼"	8¾"	4°	95°
-----	------	------	-----	----	-----

Sled-Base Chair without Arms

7¼"	N.A.	N.A.	N.A.	4°	95°
-----	------	------	------	----	-----

Leg-Base Stool with Arms

7¼"	20½"	36½"	8¾"	4°	95°
-----	------	------	-----	----	-----

Leg-Base Stool without Arms

7¼"	N.A.	N.A.	N.A.	4°	95°
-----	------	------	------	----	-----

Player 475 Series Leg-Base Multi-Use Chairs

With Open Arms or without Arms

SIN 711.18



Tip: Color choices are limited for chairs with textured plastic arms.

▶ Page 432

Standard Includes		Required to Specify	
▶ Need help? Product details, page 364	<ul style="list-style-type: none"> • Frame: monochromatic color • Arms, if selected: plastic color to match frame color • Upholstery: fabric price group 1 • Glides, if selected: plastic with stainless steel inserts • Hard composition, dual-wheel casters, if selected: black 	<ol style="list-style-type: none"> 1 Style number 2 Monochromatic color number from seating plastic colors for frame 3 Fabric color number for upholstery 4 Options, if selected (see below) 	▶ See <i>Surface Materials</i> , page 432.

Options	Price	Required to Specify	
Surface Materials			
Upholstery on seat			
• Fabric price group 1	No cost	Specify fabric color number.	
• Fabric price group 2	+\$ 13	Specify fabric color number.	
• Fabric price group 3	+\$ 24	Specify fabric color number.	
• Fabric price group 4	+\$ 34	Specify fabric color number.	
• Fabric price group 5	+\$ 42	Specify fabric color number.	
• Fabric price group 6	+\$ 60	Specify fabric color number.	
• Fabric price group 7	+\$ 85	Specify fabric color number.	
• Fabric price group 8	+\$113	Specify fabric color number.	
• Fabric price group 9	+\$134	Specify fabric color number.	
• Fabric price group 10	+\$156	Specify fabric color number.	
• Customer's Own Material/ Vinyl (COM)	+\$ 18	▶ See <i>Surface Materials Reference Manual</i> to specify.	
Upholstery on back			
• Fabric price group 1	No cost	Specify fabric color number.	
• Fabric price group 2	+\$ 13	Specify fabric color number.	
• Fabric price group 3	+\$ 24	Specify fabric color number.	
• Fabric price group 4	+\$ 34	Specify fabric color number.	
• Fabric price group 5	+\$ 43	Specify fabric color number.	
• Fabric price group 6	+\$ 61	Specify fabric color number.	
• Fabric price group 7	+\$ 86	Specify fabric color number.	
• Fabric price group 8	+\$113	Specify fabric color number.	
• Fabric price group 9	+\$134	Specify fabric color number.	
• Fabric price group 10	+\$156	Specify fabric color number.	
• Customer's Own Material/ Vinyl (COM)	+\$ 19	▶ See <i>Surface Materials Reference Manual</i> to specify.	
Soil-retardant treatment	+\$ 25	Specify <i>with soil-retardant treatment</i> .	
Platinum			
• Platinum frame	+\$ 57	Specify <i>with 6249 Platinum</i> .	
Back and Seat			
• High back	+\$ 38	Specify <i>with high back</i> .	
• Thick seat	+\$ 38	Specify <i>with thick seat</i> .	
• High back and thick seat	+\$ 76	Specify <i>with high back and thick seat</i> .	
Glides			
• Soft felt glides for use on non-carpeted floors	+\$ 6	Specify <i>with soft glides</i> .	
Casters			
• Soft, dual-wheel casters for use on hard floors	+\$ 25	Specify <i>with soft casters</i> .	

▶ Detailed dimensions, page 366

Specification Information

Style Number	Base Price
--------------	------------

Smooth Plastic Arms

With Glides

475412M	\$401
---------	-------



With Casters

475412MC	\$453
----------	-------



Textured Plastic Arms

With Glides

475415M	\$401
---------	-------



With Casters

475415MC	\$453
----------	-------



Without Arms

With Glides

475410M	\$366
---------	-------



Player 475 Series Leg-Base Multi-Use Chairs

With Tablet Arm

SIN 711.19



Standard Includes		Required to Specify
<ul style="list-style-type: none"> ▶ Need help? Product details, page 364 	<ul style="list-style-type: none"> • Frame: monochromatic color • Tablet arm: laminate • Upholstery: fabric price group 1 • Glides: plastic with stainless steel inserts 	<ol style="list-style-type: none"> 1 Style number 2 Monochromatic color number from seating plastic colors for frame 3 Fabric color number for upholstery 4 Laminate color number for tablet arm 5 Options, if selected (see below) <ul style="list-style-type: none"> ▶ See <i>Surface Materials</i>, page 432.

Options	Price	Required to Specify
Surface Materials		
Upholstery on seat		
• Fabric price group 1	No cost	Specify fabric color number.
• Fabric price group 2	+\$ 13	Specify fabric color number.
• Fabric price group 3	+\$ 24	Specify fabric color number.
• Fabric price group 4	+\$ 34	Specify fabric color number.
• Fabric price group 5	+\$ 42	Specify fabric color number.
• Fabric price group 6	+\$ 60	Specify fabric color number.
• Fabric price group 7	+\$ 85	Specify fabric color number.
• Fabric price group 8	+\$113	Specify fabric color number.
• Fabric price group 9	+\$134	Specify fabric color number.
• Fabric price group 10	+\$156	Specify fabric color number.
• Customer's Own Material/ Vinyl (COM)	+\$ 18	▶ See <i>Surface Materials Reference Manual</i> to specify.
Upholstery on back		
• Fabric price group 1	No cost	Specify fabric color number.
• Fabric price group 2	+\$ 13	Specify fabric color number.
• Fabric price group 3	+\$ 24	Specify fabric color number.
• Fabric price group 4	+\$ 34	Specify fabric color number.
• Fabric price group 5	+\$ 43	Specify fabric color number.
• Fabric price group 6	+\$ 61	Specify fabric color number.
• Fabric price group 7	+\$ 86	Specify fabric color number.
• Fabric price group 8	+\$113	Specify fabric color number.
• Fabric price group 9	+\$134	Specify fabric color number.
• Fabric price group 10	+\$156	Specify fabric color number.
• Customer's Own Material/ Vinyl (COM)	+\$ 19	▶ See <i>Surface Materials Reference Manual</i> to specify.
Soil-retardant treatment	+\$ 25	Specify with soil-retardant treatment.
Platinum		
• Platinum frame	+\$ 57	Specify with 6249 Platinum.
Back and Seat		
• High back	+\$ 38	Specify with high back.
• Thick seat	+\$ 38	Specify with thick seat.
• High back and thick seat	+\$ 76	Specify with high back and thick seat.
Glides		
• Soft felt glides for use on non-carpeted floors	+\$ 6	Specify with soft glides.

▶ Detailed dimensions, page 366

Specification Information

• Style • Number	• Base • Price
---------------------	-------------------

Right-Hand Tablet Arm

475410MTR	\$570
-----------	-------

Left-Hand Tablet Arm

475410MTL	\$570
-----------	-------



Player 475 Series Sled-Base Multi-Use Chairs

With Open Arms or without Arms

SIN 711.18



Tip: Color choices are limited for chairs with textured plastic arms.
▶ Page 365

Standard Includes		Required to Specify
▶ Need help? Product details, page 364	<ul style="list-style-type: none"> • Frame: monochromatic color • Arms, if selected: plastic color to match frame color • Upholstery: fabric price group 1 • Glides: plastic with stainless steel inserts 	<ol style="list-style-type: none"> 1 Style number 2 Monochromatic color number from seating plastic colors for frame 3 Fabric color number for upholstery 4 Options, if selected (see below) <p>▶ See <i>Surface Materials</i>, page 432.</p>

Options	Price	Required to Specify
Surface Materials		
Upholstery on seat		
• Fabric price group 1	No cost	Specify fabric color number.
• Fabric price group 2	+\$ 13	Specify fabric color number.
• Fabric price group 3	+\$ 24	Specify fabric color number.
• Fabric price group 4	+\$ 34	Specify fabric color number.
• Fabric price group 5	+\$ 42	Specify fabric color number.
• Fabric price group 6	+\$ 60	Specify fabric color number.
• Fabric price group 7	+\$ 85	Specify fabric color number.
• Fabric price group 8	+\$113	Specify fabric color number.
• Fabric price group 9	+\$134	Specify fabric color number.
• Fabric price group 10	+\$156	Specify fabric color number.
• Customer's Own Material/ Vinyl (COM)	+\$ 18	▶ See <i>Surface Materials Reference Manual</i> to specify.
Upholstery on back		
• Fabric price group 1	No cost	Specify fabric color number.
• Fabric price group 2	+\$ 13	Specify fabric color number.
• Fabric price group 3	+\$ 24	Specify fabric color number.
• Fabric price group 4	+\$ 34	Specify fabric color number.
• Fabric price group 5	+\$ 43	Specify fabric color number.
• Fabric price group 6	+\$ 61	Specify fabric color number.
• Fabric price group 7	+\$ 86	Specify fabric color number.
• Fabric price group 8	+\$113	Specify fabric color number.
• Fabric price group 9	+\$134	Specify fabric color number.
• Fabric price group 10	+\$156	Specify fabric color number.
• Customer's Own Material/ Vinyl (COM)	+\$ 19	▶ See <i>Surface Materials Reference Manual</i> to specify.
Soil-retardant treatment	+\$ 25	Specify <i>with soil-retardant treatment</i> .
Platinum		
• Platinum frame	+\$ 57	Specify <i>with 6249 Platinum</i> .
Back and Seat		
• High back	+\$ 38	Specify <i>with high back</i> .
• Thick seat	+\$ 38	Specify <i>with thick seat</i> .
• High back and thick seat	+\$ 76	Specify <i>with high back and thick seat</i> .
Glides		
• Soft felt glides for use on non-carpeted floors	+\$ 6	Specify <i>with soft glides</i> .

▶ Detailed dimensions, page 366

Specification Information

• Style • Number	• Base • Price
---------------------	-------------------



Smooth Plastic Arms

475482M	\$516
---------	-------



Textured Plastic Arms

475485M	\$516
---------	-------



Without Arms

475480M	\$481
---------	-------

SIN 711.19

Specification Information

• Style • Number	• Base • Price
---------------------	-------------------



Right-Hand Tablet Arm

475480MTR	\$685
-----------	-------



Left-Hand Tablet Arm

475480MTL	\$685
-----------	-------

Player 475 Series Leg-Base Stools

SIN 711.18



Tip: Color choices are limited for chairs with textured plastic arms.

▶ Page 365

Standard Includes		Required to Specify
▶ Need help? Product details, page 364	<ul style="list-style-type: none"> • Frame: monochromatic color • Arms, if selected: plastic color to match frame color • Upholstery: fabric price group 1 • Glides: plastic with stainless steel inserts 	1 Style number 2 Monochromatic color number from seating plastic colors for frame 3 Fabric color number for upholstery 4 Options, if selected (see below) ▶ See <i>Surface Materials</i> , page 432.

Options	Price	Required to Specify
Surface Materials		
Upholstery on seat		
• Fabric price group 1	No cost	Specify fabric color number.
• Fabric price group 2	+\$ 13	Specify fabric color number.
• Fabric price group 3	+\$ 24	Specify fabric color number.
• Fabric price group 4	+\$ 34	Specify fabric color number.
• Fabric price group 5	+\$ 42	Specify fabric color number.
• Fabric price group 6	+\$ 60	Specify fabric color number.
• Fabric price group 7	+\$ 85	Specify fabric color number.
• Fabric price group 8	+\$113	Specify fabric color number.
• Fabric price group 9	+\$134	Specify fabric color number.
• Fabric price group 10	+\$156	Specify fabric color number.
• Customer's Own Material/ Vinyl (COM)	+\$ 18	▶ See <i>Surface Materials Reference Manual</i> to specify.
Upholstery on back		
• Fabric price group 1	No cost	Specify fabric color number.
• Fabric price group 2	+\$ 13	Specify fabric color number.
• Fabric price group 3	+\$ 24	Specify fabric color number.
• Fabric price group 4	+\$ 34	Specify fabric color number.
• Fabric price group 5	+\$ 43	Specify fabric color number.
• Fabric price group 6	+\$ 61	Specify fabric color number.
• Fabric price group 7	+\$ 86	Specify fabric color number.
• Fabric price group 8	+\$113	Specify fabric color number.
• Fabric price group 9	+\$134	Specify fabric color number.
• Fabric price group 10	+\$156	Specify fabric color number.
• Customer's Own Material/ Vinyl (COM)	+\$ 19	▶ See <i>Surface Materials Reference Manual</i> to specify.
Soil-retardant treatment	+\$ 25	Specify <i>with soil-retardant treatment</i> .
Platinum		
• Platinum frame	+\$ 57	Specify <i>with 6249 Platinum</i> .
Back and Seat		
• High back	+\$ 38	Specify <i>with high back</i> .
• Thick seat	+\$ 38	Specify <i>with thick seat</i> .
• High back and thick seat	+\$ 76	Specify <i>with high back and thick seat</i> .
Glides		
• Soft felt glides for use on non-carpeted floors	+\$ 6	Specify <i>with soft glides</i> .

▶ Detailed dimensions,
page 366

Specification Information

Style Number	Base Price
--------------	------------

Smooth Plastic Arms

475712M	\$688
---------	-------



Textured Plastic Arms

475715M	\$688
---------	-------



Without Arms

475710M	\$653
---------	-------



Player 475 Series Accessories

SIN 711.18

Alignment Device

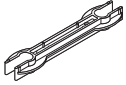

Tip: One pair is required to align two chairs.

Standard Includes	Required to Specify
<ul style="list-style-type: none"> ▶ Need help? Product details, page 364 • Alignment device: black paint only • Package of 5 pairs 	Style number

Specification Information	
• Style Number	• Price
475A	\$77

Ganging Device

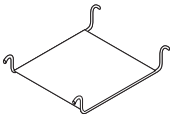

Tip: Use one ganging device for every two chairs.

Standard Includes	Required to Specify
<ul style="list-style-type: none"> ▶ Need help? Product details, page 364 • Ganging device: black paint only • Package of 2 	Style number

Specification Information	
• Style Number	• Price
475G	\$96

Transport and Storage Dolly

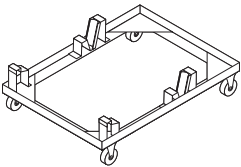

Standard Includes	Required to Specify
<ul style="list-style-type: none"> ▶ Need help? Product details, page 364 • Transport and storage dolly: black paint only 	Style number

Specification Information	
• Style Number	• Price
475D	\$320

Move 490 Series

Move chairs are guest chairs that also stack. Live dynamic seat, open cantilever arm design, light weight, and strength make Move a logical choice for multipurpose areas. Move's simple design complements a broad range of work settings.

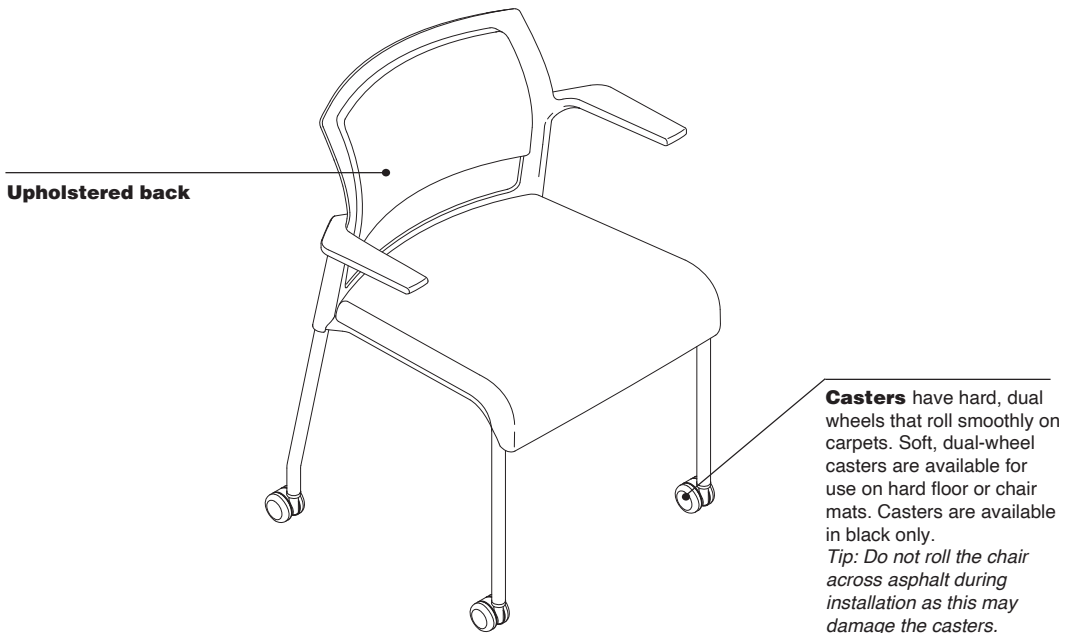
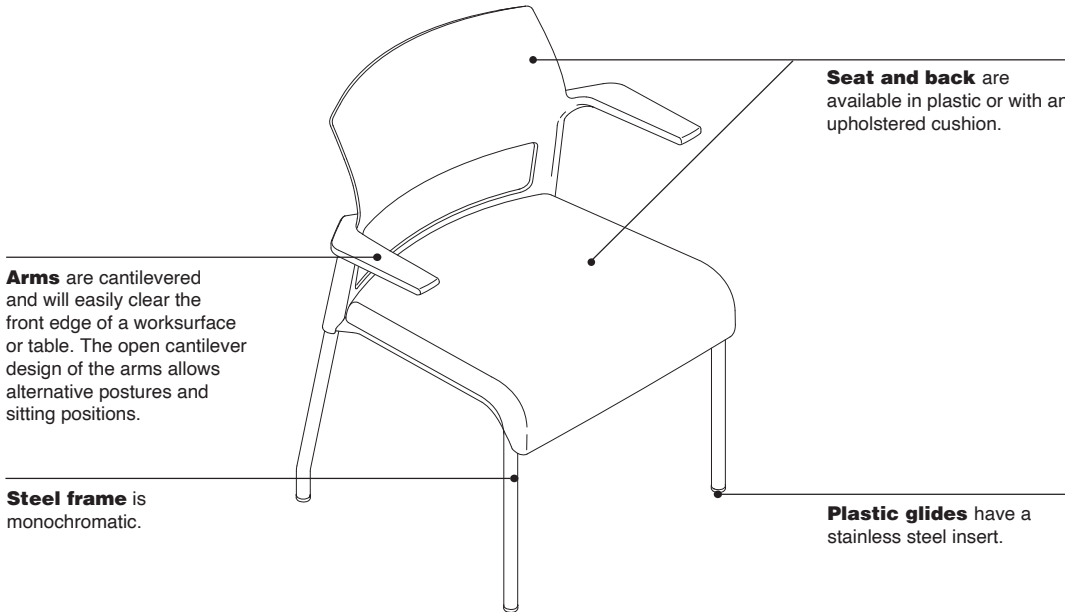

Product Details

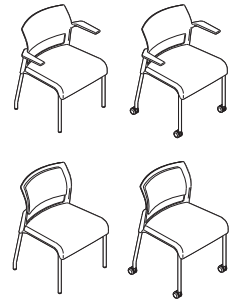

Chairs and stools have a leg-base and are available with glides or casters, and with or without arms.

Stackability for leg base models is five high on the floor. Stools do not stack.

Plastic glides with stainless steel inserts are recommended for carpeted surfaces.

Soft felt glides for use on non-carpeted surfaces are available as an option.

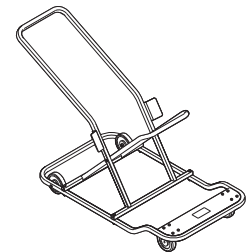

Transport and storage dolly is available to stack, move, and store up to 10 chairs.

Unloaded transport dolly measures 58½"D x 25½"W x 37½"H.

Fully loaded transport dolly measures 58½"D x 25½"W x 58½"H.



Move wall saver is available to prevent the back of the chair from making contact with the wall.

Surface Materials

▶ See surface materials on page 432 for specific availability or refer to the *Surface Materials Reference Manual* for further information.

Frame

- 0835 Black
- 4799 Platinum Metallic
- 7239 Midnight
- 4B20 Obsidian
- 4B22 Matte Brass
- 4B23 Burnished Bronze
- 4B24 Night Bronze
- 4B25 Matte Copper
- 4B26 Smoked Mica
- 4B27 Blue Steel
- 4B28 Silver Lilac
- 4B29 Cast Iron
- 4B30 Bright Gold

Seat

- Plastic
- Upholstery

Price Group 1

- Plastics
- 6009 Arctic White
 - 6059 Sterling Dark Solid
 - 6205 Black
 - 6249 Platinum Solid
 - 6259 Midnight
 - 6332 Citron
 - 6333 Picasso
 - 6334 Flash
 - 6335 Wasabi
 - 6336 Jazz
 - 6337 Element
 - 6338 Chili
 - 6BD8 Snow
 - 6BD9 Carbon Flat
 - 6BE1 Ore

Price Group 2

- Signature Plastics
- 6BC2 Purple
 - 6BC5 Blue
 - 6BC8 Gold
 - 6BD1 Aubergine
 - 6BD2 Peacock
 - 6BD3 Jungle
 - 6BD4 Merlot
 - 6BD5 Honey
 - 6BD6 Lagoon
 - 6BD7 Saffron

Upholstery

- Fabric
- Fabric with soil retardant treatment (option)
- Leather
- Elmosoft leather
- Vinyl
- Select Surfaces leather

Castors

- Black only

Glides

- Plastic with stainless steel inserts

Wall saver

- 6644 Fusion Dark only

All Steelcase seating with standard upholstery fabrics complies with requirements of the State of California Technical Bulletin 117-2013. All standard seating is labeled to be in compliance with California 117-2013.

Programs & Services

▶ See the *Surface Materials Reference Manual* for further detail about programs and services offered for seating.

Select Surfaces

For information on products within Select Surfaces, including accent paints, Signature plastics, and fabrics from Designtex, Gabriel, Kvadrat, and Pollack, please refer to the *Surface Materials Reference Manual* or visit www.steelcase.com/selectsurfaces.

Custom Surfaces

The Customer's Own Material (COM) Program offers the opportunity for customers to select fabrics that are not offered through the standard Steelcase surface materials program for use on Steelcase products. Through the COM program, Steelcase will test your materials for application on Steelcase products. Once approved, you can place your order. Steelcase will facilitate the entire ordering process and give you a production schedule. Steelcase will order the COM fabric directly from the textile manufacturer. For up-to-date information regarding fabric test results for all COM fabrics and details regarding yardage requirements for most Seating lines, visit the COM website. To locate the COM website:

- Visit www.steelcase.com

Soil retardants are treatments that provide long-term soil and stain resistance to a fabric without affecting the shade or the integrity of the fabric. The following Steelcase Textiles are available pre-treated with soil retardant. (You do not need to select the soil-retardant option for these fabrics and incur the upcharge.)

- Jacks
- Link
- Spyder

For information on soil retardant fabrics on Select Surfaces, please refer to the *Surface Materials Reference Manual*.

Soil-retardant treatment is available on all other seating fabrics at an additional upcharge per seating unit. To order this option, please select "Soil-Retardant Treatment" under "Optional Accessories."

For soil-retardant treatment on COMs, please select "Soil-Retardant Treatment" under "Optional Accessories." Minimums or additional yardage may be required. Please contact the vendor directly for specific information.

Extended lead times may be necessary for this service.

Contact your Steelcase Solutions Fulfillment Team Representative at 1.888.STEELCASE (1.888.783.3522) or send an email to lineone@steelcase.com.

Fire Codes

▶ See pages 462 for upholstery fabrics available for use with FCS modification.

Steelcase offers Fire Code Seating modification (FCS) on some seating models. The most rigorous fire codes in the nation have been developed in California, and the Steelcase FCS modification is designed to meet those codes. Fire Code Seating (FCS) indicates that a product is constructed to meet the strict fire code requirements of high public occupancy areas such as theaters, meeting rooms, and lobbies. The FCS standards will meet the State of California Bureau of Electronic and Appliance Repair, Home Furnishings, and Thermal Insulation Technical Bulletin 133 (Cal TB 133). Boston adopted the California Bureau of Electronic and Appliance Repair, Home Furnishings, and Thermal Insulation Technical Bulletin TB 133 test standard in 1992.

Local codes may have special requirements for upholstery.

Dimensions

▶ Page 382

Resources

Printed Materials

▶ Move Brochure (10-0002807)

Online Resources

▶ Environmental profiles available on www.steelcase.com/sustainability

Dimensions

Move 490 Series

Features	Overall Depth	Width	Height	Seat Depth	Functional Seat Depth	Seat Width	Seat Height from Floor	Back Width	Back Height from Seat
Move 490 Series									
Chair with Arms									
	20 ¹ / ₄ "	25 ³ / ₄ "	31 ¹ / ₂ "	18 ¹ / ₂ "	16 ⁷ / ₈ "	19"	18 ¹ / ₂ "	19"	15 ¹ / ₄ "
Plastic Chair with Arms									
	20 ¹ / ₄ "	25 ³ / ₄ "	31 ¹ / ₂ "	18 ¹ / ₂ "	16 ⁷ / ₈ "	18 ¹ / ₄ "	18"	19"	15 ¹ / ₂ "
Chair without Arms									
	20 ¹ / ₄ "	21"	31 ¹ / ₂ "	18 ¹ / ₂ "	16 ⁷ / ₈ "	19"	18 ¹ / ₂ "	19"	15 ¹ / ₄ "
Plastic Chair without Arms									
	20 ¹ / ₄ "	21"	31 ¹ / ₂ "	18 ¹ / ₂ "	16 ⁷ / ₈ "	18 ¹ / ₄ "	18"	19"	15 ¹ / ₂ "
Stool with Arms									
	20 ¹ / ₄ "	25 ³ / ₄ "	42 ¹ / ₂ "	18 ¹ / ₂ "	16 ⁷ / ₈ "	19"	29 ¹ / ₂ "	19"	15 ¹ / ₄ "
Plastic Stool with Arms									
	20 ¹ / ₄ "	25 ³ / ₄ "	42 ¹ / ₂ "	18 ¹ / ₂ "	16 ⁷ / ₈ "	18 ¹ / ₄ "	29"	19"	15 ¹ / ₂ "
Stool without Arms									
	20 ¹ / ₄ "	21"	42 ¹ / ₂ "	18 ¹ / ₂ "	16 ⁷ / ₈ "	19"	29 ¹ / ₂ "	19"	15 ¹ / ₄ "
Plastic Stool without Arms									
	20 ¹ / ₄ "	21"	42 ¹ / ₂ "	18 ¹ / ₂ "	16 ⁷ / ₈ "	18 ¹ / ₄ "	29"	19"	15 ¹ / ₂ "
Perching Stool with Arms									
	20 ¹ / ₄ "	25 ³ / ₄ "	40"	18 ¹ / ₂ "	16 ⁷ / ₈ "	19"	27"	19"	15 ¹ / ₄ "
Plastic Perching Stool with Arms									
	20 ¹ / ₄ "	25 ³ / ₄ "	40"	18 ¹ / ₂ "	16 ⁷ / ₈ "	18 ¹ / ₄ "	26 ¹ / ₂ "	19"	15 ¹ / ₂ "
Perching Stool without Arms									
	20 ¹ / ₄ "	21"	40"	18 ¹ / ₂ "	16 ⁷ / ₈ "	19"	27"	19"	15 ¹ / ₄ "
Plastic Perching Stool without Arms									
	20 ¹ / ₄ "	21"	40"	18 ¹ / ₂ "	16 ⁷ / ₈ "	18 ¹ / ₄ "	26 ¹ / ₂ "	19"	15 ¹ / ₂ "

Back Lumbar Height	Width Between Arms	Arm to Floor	Arm Height from Seat	Seat Pan Angle	Angle Between Seat and Back
--------------------	--------------------	--------------	----------------------	----------------	-----------------------------

Chair with Arms

10"	20½"	25¾"	8¾"	5°	95°
-----	------	------	-----	----	-----

Plastic Chair with Arms

10"	20½"	25¾"	8¾"	4°	96°
-----	------	------	-----	----	-----

Chair without Arms

10"	N.A.	N.A.	N.A.	5°	95°
-----	------	------	------	----	-----

Plastic Chair without Arms

10"	N.A.	N.A.	N.A.	4°	96°
-----	------	------	------	----	-----

Stool with Arms

10"	20½"	36¾"	8¾"	5°	95°
-----	------	------	-----	----	-----

Plastic Stool with Arms

10"	20½"	25¾"	8¾"	4°	96°
-----	------	------	-----	----	-----

Stool without Arms

10"	N.A.	N.A.	N.A.	5°	95°
-----	------	------	------	----	-----

Plastic Stool without Arms

10"	N.A.	N.A.	N.A.	4°	96°
-----	------	------	------	----	-----

Perching Stool with Arms

10"	20½"	34¼"	8¾"	5°	95°
-----	------	------	-----	----	-----

Plastic Perching Stool with Arms

10"	20½"	34¼"	8¾"	4°	96°
-----	------	------	-----	----	-----

Perching Stool without Arms

10"	N.A.	N.A.	N.A.	5°	95°
-----	------	------	------	----	-----

Plastic Perching Stool without Arms

10"	N.A.	N.A.	N.A.	4°	96°
-----	------	------	------	----	-----

:	:	:	:	:	:
---	---	---	---	---	---

Move 490 Series Value Package Multi-Use Chairs and Stools

Buzz2 Fabric on Seat with Black on Frame and Back Shell

SIN 711.18/711.19

Tip: Value package chairs allow you to obtain pre-selected features at a lower price than if specifying as a standard model number.

Tip: Options or substitutions are not available on this value package.

Standard Includes	Required to Specify
<ul style="list-style-type: none"> ▶ Need help? Product details, page 380 • Frame: 0835 Black paint • Back shell: 6205 Black plastic • Seat: Buzz2 fabric • Arms, if selected: 6205 Black plastic • Glides, if selected: plastic with stainless steel inserts • Hard, dual-wheel casters, if selected: black 	<ul style="list-style-type: none"> 1 Style number 2 Buzz2 fabric color number for seat 3 Options, if selected (see below) ▶ See <i>Surface Materials</i>, page 432.

Options	Price	Required to Specify
Surface Materials Upholstery <ul style="list-style-type: none"> • Fire Code Seating (FCS) 	+\$77	Add suffix F to the style number.

Specification Information	
Style Number	Base Price

Chairs without Arms

With Glides

490410V \$280

With Casters

490410VC \$330

Chairs with Arms

With Glides

490412V \$339

With Casters

490412VC \$389

▶ **Specification Information, continued on next page**



▶ Detailed dimensions, page 382

► **Specification Information, continued from previous page**

Specification Information

Style Number	Base Price
--------------	------------

Stools without Arms

With Glides

490710V	\$511
----------------	-------

With Casters

490710VC	\$561
-----------------	-------

Stools with Arms

With Glides

490712V	\$570
----------------	-------

With Casters

490712VC	\$620
-----------------	-------

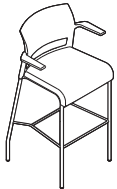
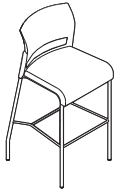

Move 490 Series Multi-Use Chairs

SIN 711.18/711.19



Standard Includes	Required to Specify
<ul style="list-style-type: none"> ▶ Need help? Product details, page 380 • Frame: 0835 Black paint • Back shell: plastic • Upholstery, if selected: fabric price group 1 • Arms, if selected: plastic to match back shell • Glides, if selected: plastic with stainless steel inserts • Hard, dual-wheel casters, if selected: black 	<ol style="list-style-type: none"> 1 Style number 2 Paint color number for frame 3 Plastic color number for back shell 4 Plastic color number for seat shell, if selected 5 Fabric color number for upholstery on seat and back, or seat, if selected 6 Options, if selected (see below) <p>▶ See <i>Surface Materials</i>, page 432.</p>

Options	Price	Required to Specify
Surface Materials		
Plastic on seat shell		
• Plastic price group 1	No cost	Specify color number. ▶ See <i>Surface Materials</i> , page 432.
• Plastic price group 2	+\$ 22	Specify color number. ▶ See <i>Surface Materials</i> , page 432.
Plastic on back shell		
• Plastic price group 1	No cost	Specify color number. ▶ See <i>Surface Materials</i> , page 432.
• Plastic price group 2	+\$ 22	Specify color number. ▶ See <i>Surface Materials</i> , page 432.
Upholstery on seat and back		
• Fabric price group 1	No cost	Specify fabric color number.
• Fabric price group 2	+\$ 26	Specify fabric color number.
• Fabric price group 3	+\$ 48	Specify fabric color number.
• Fabric price group 4	+\$ 68	Specify fabric color number.
• Fabric price group 5	+\$ 85	Specify fabric color number.
• Fabric price group 6	+\$121	Specify fabric color number.
• Fabric price group 7	+\$171	Specify fabric color number.
• Fabric price group 8	+\$226	Specify fabric color number.
• Fabric price group 9	+\$268	Specify fabric color number.
• Fabric price group 10	+\$312	Specify fabric color number.
• Steelcase leather upholstery	+\$177	Specify leather color number.
• Select Surfaces leather price group 1	+\$177	▶ See <i>Surface Materials Reference Manual</i> .
• Elmosoft leather upholstery	+\$205	Specify Elmosoft leather color number.
• Select Surfaces leather price group 2	+\$205	▶ See <i>Surface Materials Reference Manual</i> .
• Customer's Own Material/Vinyl (COM)	No cost	▶ See <i>Surface Materials Reference Manual</i> to specify.
• Customer's Own Leather (COL)	No cost	Specify leather color number.
Contrasting upholstery on seat and back		
• Contrasting fabrics	+\$ 31	Add suffix K to the style number and specify fabric color numbers.
Contrasting upholstery on seat		
• Fabric price group 1	No cost	Specify fabric color number.
• Fabric price group 2	+\$ 10	Specify fabric color number.
• Fabric price group 3	+\$ 26	Specify fabric color number.
• Fabric price group 4	+\$ 35	Specify fabric color number.
• Fabric price group 5	+\$ 42	Specify fabric color number.
• Fabric price group 6	+\$ 60	Specify fabric color number.
• Fabric price group 7	+\$ 85	Specify fabric color number.
• Fabric price group 8	+\$113	Specify fabric color number.
• Fabric price group 9	+\$134	Specify fabric color number.
• Fabric price group 10	+\$156	Specify fabric color number.
• Steelcase leather upholstery	+\$ 88	Specify leather color number.
• Select Surfaces leather price group 1	+\$ 88	▶ See <i>Surface Materials Reference Manual</i> .
• Elmosoft leather upholstery	+\$102	Specify Elmosoft leather color number.
• Select Surfaces leather price group 2	+\$102	▶ See <i>Surface Materials Reference Manual</i> .
• Customer's Own Material/Vinyl (COM)	No cost	▶ See <i>Surface Materials Reference Manual</i> .
• Customer's Own Leather (COL)	No cost	Specify leather color number.

Tip: Suffixes other than K for contrasting fabric, will be added in alphabetical order when specifying options. The contrasting fabric suffix, K, will always be at the end of the style number.

▶ Options, continued on next page

▶ Detailed dimensions, page 382

► Options, continued from previous page

Options	Price	Required to Specify
Surface Materials, continued	Contrasting upholstery on back	
• Fabric price group 1	No cost	Specify fabric color number.
• Fabric price group 2	+\$ 16	Specify fabric color number.
• Fabric price group 3	+\$ 22	Specify fabric color number.
• Fabric price group 4	+\$ 33	Specify fabric color number.
• Fabric price group 5	+\$ 43	Specify fabric color number.
• Fabric price group 6	+\$ 61	Specify fabric color number.
• Fabric price group 7	+\$ 86	Specify fabric color number.
• Fabric price group 8	+\$113	Specify fabric color number.
• Fabric price group 9	+\$134	Specify fabric color number.
• Fabric price group 10	+\$156	Specify fabric color number.
• Steelcase leather upholstery	+\$ 88	Specify leather color number.
• Select Surfaces leather price group 1	+\$ 89	► See <i>Surface Materials Reference Manual</i> .
• Elmosoft leather upholstery	+\$103	Specify Elmosoft leather color number.
• Select Surfaces leather price group 2	+\$103	► See <i>Surface Materials Reference Manual</i> .
• Customer's Own Material/Vinyl (COM)	No cost	► See <i>Surface Materials Reference Manual</i> .
• Customer's Own Leather (COL)	No cost	Specify leather color number.
	Fire Code Seating (FCS)	+\$ 77
	Soil-retardant treatment	+\$ 25
	Frame	
• 7239 Midnight	No cost	Specify with 7239 Midnight.
• 4799 Platinum Metallic	+\$ 57	Specify with 4799 Platinum Metallic.
• Lux Coatings	+\$ 84	Specify Lux Coatings color number.
Glides	• Soft felt glides for use on non-carpeted floors	+\$ 6
		Specify with soft glides.
Casters	• Soft, dual-wheel casters for use on hard floors	+\$ 25
		Specify with soft casters.

Tip: Fire Code Seating (FCS) option is available only on models with 6205 Black or 6249 Platinum Solid plastic components.
► Pages 462 for upholstery fabric choices.

Specification Information

Style Number	Base Price
.	.
.	.

Upholstered Seat without Arms

With Glides

490410	\$295
---------------	-------

With Casters

490410C	\$345
----------------	-------

► Specification Information, continued on next page

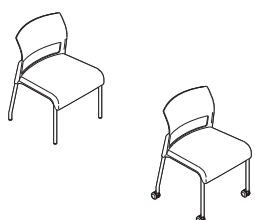

Move 490 Series Multi-Use Chairs, continued

SIN 711.18/711.19

► Specification Information, continued from previous page

Specification Information

Style Number	Base Price
--------------	------------

Upholstered Back and Seat without Arms

With Glides

490410U	\$354
----------------	-------

With Casters

490410UC	\$404
-----------------	-------

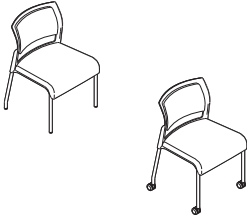

Plastic Back and Seat without Arms

With Glides

490410P	\$232
----------------	-------

With Casters

490410CP	\$282
-----------------	-------

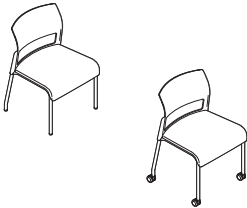

Upholstered Seat with Arms

With Glides

490412	\$354
---------------	-------

With Casters

490412C	\$404
----------------	-------

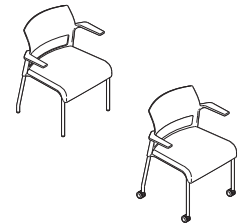

Upholstered Back and Seat with Arms

With Glides

490412U	\$413
----------------	-------

With Casters

490412UC	\$463
-----------------	-------

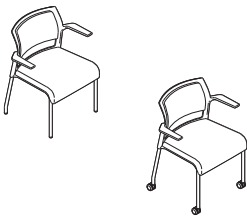

Plastic Back and Seat with Arms

With Glides

490412P	\$291
----------------	-------

With Casters

490412CP	\$341
-----------------	-------

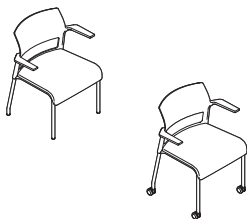

Tip: Plastic finish number must be specified for both seat and back on plastic styles.

Move 490 Series Multi-Use Stools

SIN 711.18

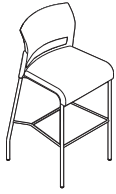

Standard Includes	Required to Specify
<ul style="list-style-type: none"> ▶ Need help? Product details, page 380 • Frame: 0835 Black paint • Back shell: plastic • Upholstery, if selected: fabric price group 1 • Arms, if selected: plastic to match back shell • Glides, if selected: plastic with stainless steel inserts • Hard, dual-wheel casters, if selected: black 	<ol style="list-style-type: none"> 1 Style number 2 Paint color number for frame 3 Plastic color number for back shell 4 Plastic color number for seat shell, if selected 5 Fabric color number for upholstery on seat and back, or seat, if selected 6 Options, if selected (see below) <p>▶ See <i>Surface Materials</i>, page 432.</p>

Surface Materials	Options	Price	Required to Specify
	Plastic on seat shell		
	• Plastic price group 1	No cost	Specify color number. ▶ See <i>Surface Materials</i> , page 432.
	• Plastic price group 2	+\$ 22	Specify color number. ▶ See <i>Surface Materials</i> , page 432.
	Plastic on back shell		
	• Plastic price group 1	No cost	Specify color number. ▶ See <i>Surface Materials</i> , page 432.
	• Plastic price group 2	+\$ 22	Specify color number. ▶ See <i>Surface Materials</i> , page 432.
	Upholstery on seat and back		
	• Fabric price group 1	No cost	Specify fabric color number.
	• Fabric price group 2	+\$ 26	Specify fabric color number.
	• Fabric price group 3	+\$ 48	Specify fabric color number.
	• Fabric price group 4	+\$ 68	Specify fabric color number.
	• Fabric price group 5	+\$ 85	Specify fabric color number.
	• Fabric price group 6	+\$121	Specify fabric color number.
	• Fabric price group 7	+\$171	Specify fabric color number.
	• Fabric price group 8	+\$226	Specify fabric color number.
	• Fabric price group 9	+\$268	Specify fabric color number.
	• Fabric price group 10	+\$312	Specify fabric color number.
	• Steelcase leather upholstery	+\$177	Specify leather color number.
	• Select Surfaces leather price group 1	+\$177	▶ See <i>Surface Materials Reference Manual</i> .
	• Elmosoft leather upholstery	+\$205	Specify Elmosoft leather color number.
	• Select Surfaces leather price group 2	+\$205	▶ See <i>Surface Materials Reference Manual</i> .
	• Customer's Own Material/Vinyl (COM)	No cost	▶ See <i>Surface Materials Reference Manual</i> to specify.
	• Customer's Own Leather (COL)	No cost	Specify leather color number.
	Contrasting upholstery on seat and back		
	• Contrasting fabrics	+\$ 31	Add suffix K to the style number and specify fabric color numbers.
	Contrasting upholstery on seat		
	• Fabric price group 1	No cost	Specify fabric color number.
	• Fabric price group 2	+\$ 10	Specify fabric color number.
	• Fabric price group 3	+\$ 26	Specify fabric color number.
	• Fabric price group 4	+\$ 35	Specify fabric color number.
	• Fabric price group 5	+\$ 42	Specify fabric color number.
	• Fabric price group 6	+\$ 60	Specify fabric color number.
	• Fabric price group 7	+\$ 85	Specify fabric color number.
	• Fabric price group 8	+\$113	Specify fabric color number.
	• Fabric price group 9	+\$134	Specify fabric color number.
	• Fabric price group 10	+\$156	Specify fabric color number.
	• Steelcase leather upholstery	+\$ 88	Specify leather color number.
	• Select Surfaces leather price group 1	+\$ 88	▶ See <i>Surface Materials Reference Manual</i> .
	• Elmosoft leather upholstery	+\$102	Specify Elmosoft leather color number.
	• Select Surfaces leather price group 2	+\$102	▶ See <i>Surface Materials Reference Manual</i> .
	• Customer's Own Material/Vinyl (COM)	No cost	▶ See <i>Surface Materials Reference Manual</i> .
	• Customer's Own Leather (COL)	No cost	Specify leather color number.

▶ Options, continued on next page

Tip: Suffixes other than K for contrasting fabric, will be added in alphabetical order when specifying options. The contrasting fabric suffix, K, will always be at the end of the style number.

▶ Detailed dimensions, page 382

► Options, continued from previous page

Options	Price	Required to Specify	
Surface Materials, continued			
Contrasting upholstery on back			
• Fabric price group 1	No cost	Specify fabric color number.	
• Fabric price group 2	+\$ 16	Specify fabric color number.	
• Fabric price group 3	+\$ 22	Specify fabric color number.	
• Fabric price group 4	+\$ 33	Specify fabric color number.	
• Fabric price group 5	+\$ 43	Specify fabric color number.	
• Fabric price group 6	+\$ 61	Specify fabric color number.	
• Fabric price group 7	+\$ 86	Specify fabric color number.	
• Fabric price group 8	+\$113	Specify fabric color number.	
• Fabric price group 9	+\$134	Specify fabric color number.	
• Fabric price group 10	+\$156	Specify fabric color number.	
• Steelcase leather upholstery	+\$ 89	Specify leather color number.	
• Select Surfaces leather price group 1	+\$ 89	► See <i>Surface Materials Reference Manual</i> .	
• Elmosoft leather upholstery	+\$103	Specify Elmosoft leather color number.	
• Select Surfaces leather price group 2	+\$103	► See <i>Surface Materials Reference Manual</i> .	
• Customer's Own Material/Vinyl (COM)	No cost	► See <i>Surface Materials Reference Manual</i> .	
• Customer's Own Leather (COL)	No cost	Specify leather color number.	
Fire Code Seating (FCS)	+\$ 77	Add suffix F to the style number.	
Soil-retardant treatment	+\$ 25	Specify with soil-retardant treatment.	
Frame			
• 7239 Midnight	No cost	Specify with 7239 Midnight.	
• 4799 Platinum Metallic	+\$ 57	Specify with 4799 Platinum Metallic.	
• Lux Coatings	+\$ 84	Specify Lux Coatings color number.	
Glides	• Soft felt glides for use on non-carpeted floors	+\$ 6	Specify with soft glides.
Casters	• Soft, dual-wheel casters for use on hard floors	+\$ 25	Specify with soft casters.

Tip: Fire Code Seating (FCS) option is available only on models with 6205 Black or 6249 Platinum Solid plastic components.
► Pages 462 for upholstery fabric choices.

Specification Information

Style Number	Base Price
:	:
:	:

Upholstered Seat without Arms

With Glides

490710 \$526

With Casters

490710C \$576

Upholstered Back and Seat without Arms

With Glides

490710U \$585

With Casters

490710UC \$635

► Specification Information, continued on next page

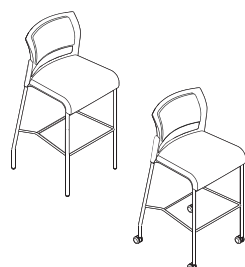

Move 490 Series Multi-Use Stools, continued

SIN 711.18

► Specification Information, continued from previous page

Specification Information

Style Number	Base Price
--------------	------------

Plastic Back and Seat without Arms

With Glides

490710P	\$456
---------	-------

With Casters

490710CP	\$506
----------	-------



Tip: Plastic finish number must be specified for both seat and back on plastic styles.

Upholstered Seat with Arms

With Glides

490712	\$585
--------	-------

With Casters

490712C	\$635
---------	-------



Upholstered Back and Seat with Arms

With Glides

490712U	\$644
---------	-------

With Casters

490712UC	\$694
----------	-------



Plastic Back and Seat with Arms

With Glides

490712P	\$515
---------	-------

With Casters

490712CP	\$565
----------	-------



Tip: Plastic finish number must be specified for both seat and back on plastic styles.

Seating

Move 490 Series
Multi-Use Stools

SIN 711.18

Move 490 Series

Move 490 Series Perching Stools

SIN 711.18

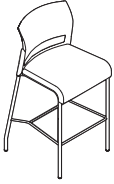

Tip: Move 490 series stools do not stack.

Standard Includes	Required to Specify
<ul style="list-style-type: none"> ▶ Need help? Product details, page 380 • Frame: 0835 Black paint • Back shell: plastic • Upholstery, if selected: fabric price group 1 • Arms, if selected: plastic to match back shell • Glides, if selected: plastic with hard plastic inserts 	<ol style="list-style-type: none"> 1 Style number 2 Paint color number for frame 3 Plastic color number for back shell 4 Plastic color number for seat shell, if selected 5 Fabric color number for upholstery on seat, if selected 6 Options, if selected (see below) <p>▶ See <i>Surface Materials</i>, page 432.</p>

Options	Price	Required to Specify
Surface Materials Plastic on seat shell <ul style="list-style-type: none"> • Plastic price group 1 • Plastic price group 2 	No cost +\$ 22	Specify color number. ▶ See <i>Surface Materials</i> , page 432. Specify color number. ▶ See <i>Surface Materials</i> , page 432.
Plastic on back shell <ul style="list-style-type: none"> • Plastic price group 1 • Plastic price group 2 	No cost +\$ 22	Specify color number. ▶ See <i>Surface Materials</i> , page 432. Specify color number. ▶ See <i>Surface Materials</i> , page 432.
Upholstery on seat and back <ul style="list-style-type: none"> • Fabric price group 1 • Fabric price group 2 • Fabric price group 3 • Fabric price group 4 • Fabric price group 5 • Fabric price group 6 • Fabric price group 7 • Fabric price group 8 • Fabric price group 9 • Fabric price group 10 • Steelcase leather upholstery • Select Surfaces leather price group 1 • Elmosoft leather upholstery • Select Surfaces leather price group 2 • Customer's Own Material/Vinyl (COM) • Customer's Own Leather (COL) 	No cost +\$ 26 +\$ 48 +\$ 68 +\$ 85 +\$121 +\$171 +\$226 +\$268 +\$312 +\$177 +\$177 +\$205 +\$205 No cost No cost	Specify fabric color number. Specify fabric color number. Specify fabric color number. Specify fabric color number. Specify fabric color number. Specify fabric color number. Specify fabric color number. Specify fabric color number. Specify fabric color number. Specify fabric color number. Specify fabric color number. Specify leather color number. ▶ See <i>Surface Materials Reference Manual</i> . Specify Elmosoft leather color number. ▶ See <i>Surface Materials Reference Manual</i> . ▶ See <i>Surface Materials Reference Manual</i> to specify. Specify leather color number.
Contrasting upholstery on seat and back <ul style="list-style-type: none"> • Contrasting fabrics 	+\$ 31	Add suffix K to the style number and specify fabric color numbers.
Contrasting upholstery on seat <ul style="list-style-type: none"> • Fabric price group 1 • Fabric price group 2 • Fabric price group 3 • Fabric price group 4 • Fabric price group 5 • Fabric price group 6 • Fabric price group 7 • Fabric price group 8 • Fabric price group 9 • Fabric price group 10 • Steelcase leather upholstery • Select Surfaces leather price group 1 • Elmosoft leather upholstery • Select Surfaces leather price group 2 • Customer's Own Material/Vinyl (COM) • Customer's Own Leather (COL) 	No cost +\$ 10 +\$ 26 +\$ 35 +\$ 42 +\$ 60 +\$ 85 +\$113 +\$134 +\$156 +\$ 88 +\$ 88 +\$102 +\$102 No cost No cost	Specify fabric color number. Specify fabric color number. Specify fabric color number. Specify fabric color number. Specify fabric color number. Specify fabric color number. Specify fabric color number. Specify fabric color number. Specify fabric color number. Specify fabric color number. Specify leather color number. ▶ See <i>Surface Materials Reference Manual</i> . Specify Elmosoft leather color number. ▶ See <i>Surface Materials Reference Manual</i> . ▶ See <i>Surface Materials Reference Manual</i> . Specify leather color number.

▶ Detailed dimensions, page 382

▶ Options, continued on next page

► Options, continued from previous page

Options	Price	Required to Specify
Surface Materials, continued	Contrasting upholstery on back	
• Fabric price group 1	No cost	Specify fabric color number.
• Fabric price group 2	+\$ 16	Specify fabric color number.
• Fabric price group 3	+\$ 22	Specify fabric color number.
• Fabric price group 4	+\$ 33	Specify fabric color number.
• Fabric price group 5	+\$ 43	Specify fabric color number.
• Fabric price group 6	+\$ 61	Specify fabric color number.
• Fabric price group 7	+\$ 86	Specify fabric color number.
• Fabric price group 8	+\$113	Specify fabric color number.
• Fabric price group 9	+\$134	Specify fabric color number.
• Fabric price group 10	+\$156	Specify fabric color number.
• Steelcase leather upholstery	+\$ 89	Specify leather color number.
• Select Surfaces leather price group 1	+\$ 89	► See <i>Surface Materials Reference Manual</i> .
• Elmosoft leather upholstery	+\$103	Specify Elmosoft leather color number.
• Select Surfaces leather price group 2	+\$103	► See <i>Surface Materials Reference Manual</i> .
• Customer's Own Material/Vinyl (COM)	No cost	► See <i>Surface Materials Reference Manual</i> .
• Customer's Own Leather (COL)	No cost	Specify leather color number.
	Fire Code Seating (FCS)	+\$ 77
	Soil-retardant treatment	+\$ 25
	Frame	
• 7239 Midnight	No cost	Specify with 7239 Midnight.
• 4799 Platinum Metallic	+\$ 57	Specify with 4799 Platinum Metallic.
• Lux Coatings	+\$ 84	Specify Lux Coatings color number.
Glides	• Soft felt glides for use on non-carpeted floors	+\$ 6
		Specify with soft glides.
Casters	• Soft, dual-wheel casters for use on hard floors	+\$ 25
		Specify with soft casters.

Tip: Fire Code Seating (FCS) option is available only on models with 6205 Black or 6249 Platinum Solid plastic components.
► Pages 462 for upholstery fabric choices.

Specification Information

Style Number	Base Price
:	:
:	:

Upholstered Seat without Arms

490510	\$526
:	:
:	:

Upholstered Back and Seat without Arms

490510U	\$585
:	:
:	:

► Specification Information, continued on next page

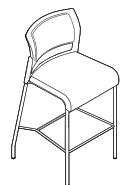
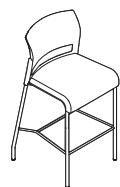

Seating

Move 490 Series Perching Stools, continued

SIN 711.18

► Specification Information, continued from previous page

Specification Information

Style Number	Base Price
--------------	------------

Plastic Back and Seat without Arms

490510P	\$456
---------	-------

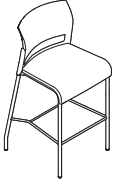

Tip: Plastic finish number must be specified for both seat and back on plastic styles.

Upholstered Seat with Arms

490512	\$585
--------	-------

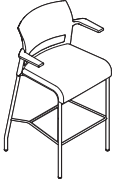

Upholstered Back and Seat with Arms

490512U	\$644
---------	-------

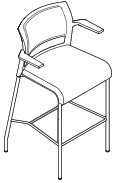

Plastic Back and Seat with Arms

490512P	\$515
---------	-------



Tip: Plastic finish number must be specified for both seat and back on plastic styles.

Move 490 Series Accessories

SIN 711.19

Transport and Storage Dolly

Standard Includes		Required to Specify
<ul style="list-style-type: none"> ▶ Need help? Product details, page 380 	<ul style="list-style-type: none"> • Transport and storage dolly: black paint only 	Style number

Specification Information	
Style Number	Price
490D	\$744
:	:
:	:



Move 490 Series

Wall Saver

Standard Includes		Required to Specify
<ul style="list-style-type: none"> ▶ Need help? Product details, page 380 	<ul style="list-style-type: none"> • Package of four • Plastic: 6644 Fusion Dark only 	Style number

Specification Information		
Style Number	Width	Price
490WS	4"	\$50
:	:	:
:	:	:



Tip: Wall saver package is for use on Move chair styles only.

Tip: One pair is required for each chair.

Snodgrass 474 Series

Snodgrass, designed by Warren Snodgrass, offers guest and occasional seating of classic simplicity. With a choice of metal or wood frames, Snodgrass has enduring design that is always in style.

Frame is available in monochromatic colors or wood veneer.

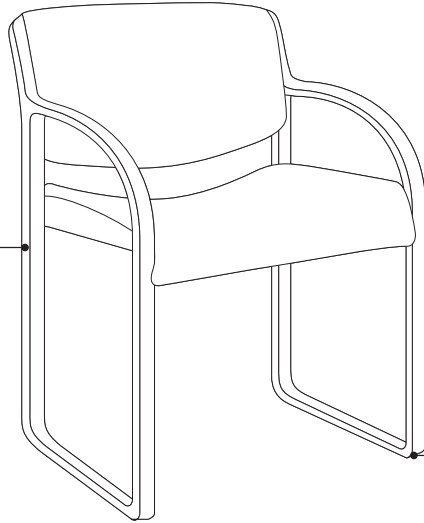

Glides are clear plastic.

Product Details

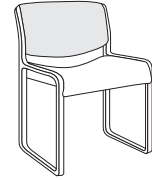

Armless chairs are available monochromatic only.

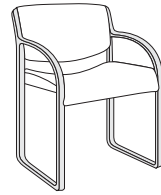

Open arms are available on monochromatic and wood models.

Surface Materials

► See surface materials on page 432 for specific availability or refer to the *Surface Materials Reference Manual* for further information.

Upholstery

- Fabric
- Fabric with soil retardant treatment (option)
- Leather
- Elmosoft leather
- Select Surfaces leather
- Vinyl

Frame

- Monochromatic color from list of seating plastic color numbers can be applied to the frame.
- Wood

Tip: Frames are constructed of solid maple. Finishes applied to maple will match the color of stains applied to oak, walnut, or cherry, but will not show the same natural grain.

Glides

- Clear plastic

All Steelcase seating with standard upholstery fabrics complies with requirements of the State of California Technical Bulletin 117-2013. All standard seating is labeled to be in compliance with California 117-2013.

Programs & Services

► See the *Surface Materials Reference Manual* for further detail about programs and services offered for seating.

The Customer's Own Material (COM) Program

offers the opportunity for customers to select fabrics that are not offered through the standard Steelcase surface materials program for use on Steelcase products. Through the COM program, Steelcase will test your materials for application on Steelcase products. Once approved, you can place your order. Steelcase will facilitate the entire ordering process and give you a production schedule. Steelcase will order the COM fabric directly from the textile manufacturer. For up-to-date information regarding fabric test results for all COM fabrics and details regarding yardage requirements for most Seating lines, visit the COM website. To locate the COM website:

- Visit www.steelcase.com

Soil retardants are treatments that provide long-term soil and stain resistance to a fabric without affecting the shade or the integrity of the fabric. The following Steelcase Textiles are available pre-treated with soil retardant. (You do not need to select the soil-retardant option for these fabrics and incur the upcharge.)

- Jacks
- Link
- Spyder

For information on soil retardant fabrics on Select Surfaces, please refer to the *Surface Materials Reference Manual*.

Soil-retardant treatment is available on all other seating fabrics at an additional upcharge. To order this option, please select "Soil-Retardant Treatment" under "Optional Accessories."

For soil-retardant treatment on COMs, please select "Soil-Retardant Treatment" under "Optional Accessories." Minimums or additional yardage may be required. Please contact the vendor directly for specific information.

Extended lead times may be necessary for this service.

Contact your Steelcase Solutions Fulfillment Team Representative at 1.888.STEELCASE (1.888.783.3522) or send an email to lineone@steelcase.com.

Dimensions

► Page 400

Resources

Printed Materials

- Snodgrass Brochure (11-0002246)
- Wood Solutions Overview Brochure (09-0000206)

Online Resources

- Environmental profiles available on www.steelcase.com/sustainability

Dimensions

Snodgrass 474 Series

Features	Overall Depth	Width	Height	Seat Depth	Functional Seat Depth	Seat Width	Seat Height from Floor	Back Width	Back Height from Seat
Snodgrass 474 Series									
Chair with Open Loop Arms									
	23½"	22¾"	31½"	21"	17½"	20"	18¼"	20"	14¼"
Chair without Arms									
	23½"	22¾"	31½"	21"	17½"	20"	18¼"	20"	14¼"

• Back Lumbar Height	• Width Between Arms	• Arm to Floor	• Arm Height from Seat	• Seat Pan Angle	• Angle Between Seat and Back
----------------------	----------------------	----------------	------------------------	------------------	-------------------------------

Chair with Open Loop Arms

7"	20"	25¼"	7"	5°	103°
----	-----	------	----	----	------

Chair without Arms

7"	20"	25¼"	7"	5°	103°
----	-----	------	----	----	------

Snodgrass 474 Series Multi-Use Chairs

SIN 711.18



Standard Includes	Required to Specify
<ul style="list-style-type: none"> ▶ Need help? Product details, page 398 • Frame and arms, if selected: monochromatic color or wood group 1 veneer • Upholstery: fabric price group 1 • Glides: clear plastic 	<ol style="list-style-type: none"> 1 Style number 2 Fabric color number for upholstery 3 Monochromatic color number from seating plastic colors for frame, if applicable. 4 Wood veneer color number for frame, if applicable 5 Options, if selected (see below) <p>▶ See <i>Surface Materials</i>, page 432.</p>

Options	Price	Required to Specify
Surface Materials Upholstery on seat and back <ul style="list-style-type: none"> • Fabric price group 1 • Fabric price group 2 • Fabric price group 3 • Fabric price group 4 • Fabric price group 5 • Fabric price group 6 • Fabric price group 7 • Fabric price group 8 • Fabric price group 9 • Fabric price group 10 • Leather price group • Select Surfaces leather price group 1 • Elmosoft leather upholstery • Select Surfaces leather price group 2 • Customer's Own Material (COM) or Customer's Own Leather (COL) 	No cost +\$ 26 +\$ 48 +\$ 68 +\$ 85 +\$106 +\$121 +\$153 +\$188 +\$213 +\$548 +\$548 +\$633 +\$633 +\$ 37	Specify fabric color number. Specify fabric color number. Specify fabric color number. Specify fabric color number. Specify fabric color number. Specify fabric color number. Specify fabric color number. Specify fabric color number. Specify fabric color number. Specify fabric color number. Specify fabric color number. Specify leather color number. ▶ See <i>Surface Materials Reference Manual</i> . Specify Elmosoft leather color number. ▶ See <i>Surface Materials Reference Manual</i> . ▶ See <i>Surface Materials Reference Manual</i> .
Contrasting upholstery on seat and back <ul style="list-style-type: none"> • Contrasting fabrics 	+\$ 31	Add suffix K to the style number and specify fabric color numbers.
Contrasting upholstery on seat <ul style="list-style-type: none"> • Fabric price group 1 • Fabric price group 2 • Fabric price group 3 • Fabric price group 4 • Fabric price group 5 • Fabric price group 6 • Fabric price group 7 • Fabric price group 8 • Fabric price group 9 • Fabric price group 10 • Steelcase leather upholstery • Select Surfaces leather price group 1 • Elmosoft leather upholstery • Select Surfaces leather price group 2 • Customer's Own Material (COM) • Customer's Own Leather (COL) 	No cost +\$ 13 +\$ 24 +\$ 34 +\$ 42 +\$ 53 +\$ 60 +\$ 76 +\$ 94 +\$106 +\$274 +\$274 +\$316 +\$316 +\$ 18 +\$ 18	Specify fabric color number. Specify fabric color number. Specify fabric color number. Specify fabric color number. Specify fabric color number. Specify fabric color number. Specify fabric color number. Specify fabric color number. Specify fabric color number. Specify fabric color number. Specify leather color number. ▶ See <i>Surface Materials Reference Manual</i> to specify. Specify Elmosoft leather color number. ▶ See <i>Surface Materials Reference Manual</i> to specify. ▶ See <i>Surface Materials Reference Manual</i> to specify. ▶ See <i>Surface Materials Reference Manual</i> to specify.

▶ Options, continued on next page

▶ Detailed dimensions, page 400

► Options, continued from previous page

Options	Price	Required to Specify
Surface Materials, continued		
Contrasting upholstery on back		
• Fabric price group 1	No cost	Specify fabric color number.
• Fabric price group 2	+\$ 13	Specify fabric color number.
• Fabric price group 3	+\$ 24	Specify fabric color number.
• Fabric price group 4	+\$ 34	Specify fabric color number.
• Fabric price group 5	+\$ 43	Specify fabric color number.
• Fabric price group 6	+\$ 53	Specify fabric color number.
• Fabric price group 7	+\$ 61	Specify fabric color number.
• Fabric price group 8	+\$ 77	Specify fabric color number.
• Fabric price group 9	+\$ 94	Specify fabric color number.
• Fabric price group 10	+\$107	Specify fabric color number.
• Steelcase leather upholstery	+\$274	Specify leather color number.
• Select Surfaces leather price group 1	+\$274	► See <i>Surface Materials Reference Manual</i> to specify.
• Elmosoft leather upholstery	+\$317	Specify Elmosoft leather color number.
• Select Surfaces leather price group 2	+\$317	► See <i>Surface Materials Reference Manual</i> to specify.
• Customer's Own Material (COM)	+\$ 19	► See <i>Surface Materials Reference Manual</i> to specify.
• Customer's Own Leather (COL)	+\$ 19	► See <i>Surface Materials Reference Manual</i> to specify.
Soil-retardant treatment	+\$ 25	Specify with soil-retardant treatment.
Frame		
• Customiz stain on wood	No cost	Specify with Customiz stain. ► See <i>Surface Materials Reference Manual</i> .

Snodgrass 474 Series

Specification Information

Open Loop Arms with Open Back



• Style Number	• Base Price

Armless with Open Back



• Style Number	• Base Price

Monochromatic

474419M	\$ 874	474410M	\$831
----------------	--------	----------------	-------

Wood

474419W	\$1164
----------------	--------

Collaboration

Collaboration guest chairs, designed by Dennie Pimental and John Duffy, have a classic design that is ideal for conference room, reception area, and dining room seating, or as guest seating in a workstation. Several arm inserts are available to create different visual details.

Inserts can match or contrast with frame color.

Back and seat are fully upholstered.

Upholstered seat features a webbed panel construction.

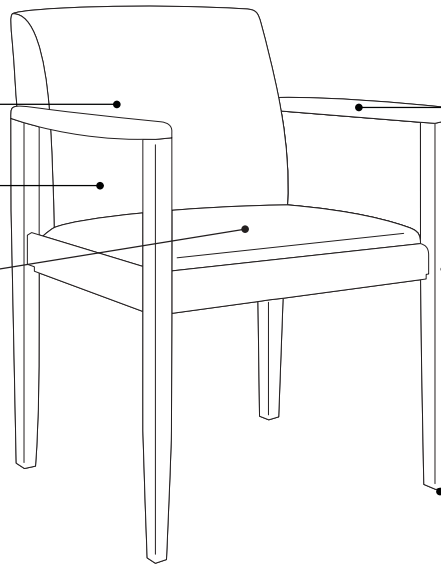

Arms may be enclosed with upholstery or European Beech inserts, or left open.

Frame is European Beech.

Glides are 1/2" diameter.

Actual Dimensions

Overall depth	24 1/4"
Overall width	22 1/2"
Overall height	31 1/2"
Seat depth	17"
Seat width	18 3/4"
Back width	18 3/4"
Back height	13 3/4"
Width between arms	18 3/4"
Seat to floor height	18"
Arm height from floor	25 1/2"

Product Details

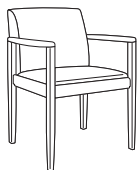

Open-arm chair is the simplest variation in the Collaboration family.

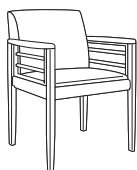

Ladder chair inserts establish a strong horizontal direction.

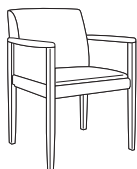

Upholstered inserts enclose the arms with fabric-covered panels.

All inserts are factory-installed.

All chairs are available with plain hardwood arms.

Surface Materials

Upholstery

- Fabric
- Fabric with soil-retardant treatment (option)
- Leather
- COM
- COL

Frame

- European Beech
- Tip: Wood finishes applied to European Beech will match the color of stains applied to oak, walnut, or cherry but will not show the same natural grain.*
- Customiz stain (option)

Inserts

- Upholstery
- European Beech
- Customiz stain (option)

Glides

- Stainless steel only

All Steelcase seating with standard upholstery fabrics

complies with requirements of the State of California Technical Bulletin 117-2013. All standard seating is labeled to be in compliance with California 117-2013.

Programs & Services

▶ See the *Surface Materials Reference Manual* for further detail about programs and services offered for seating.

The Customer's Own Material (COM & COL)

Program offers the opportunity for customers to select fabrics and leather that are not offered through the standard Steelcase surface materials program for use on Steelcase products. Avoid pattern fabrics and heavily grained leathers. Through the COM & COL program, Steelcase will test your materials for application on Steelcase products. Once approved, you can place your order. Steelcase will facilitate the entire ordering process and give you a production schedule. Steelcase will order the COM & COL fabric and leather directly from the textile manufacturer. For up-to-date information regarding fabric test results for all COM & COL fabrics and details regarding yardage requirements for most Seating lines, visit the COM website. To locate the COM website:

- Visit www.steelcase.com

Soil retardants are treatments that provide long-term soil and stain resistance to a fabric without affecting the shade or the integrity of the fabric. The following Steelcase Textiles are available pre-treated with soil retardant. (You do not need to select the soil-retardant option for these fabrics and incur the upcharge.)

- Jacks
- Link
- Spyder

For information on soil retardant fabrics on Select Surfaces, please refer to the *Surface Materials Reference Manual*.

Soil-retardant treatment is available on all other seating fabrics at an additional upcharge per seating unit. To order this option, please select "Soil-Retardant Treatment" under "Optional Accessories."

For soil-retardant treatment on COMs, please select "Soil-Retardant Treatment" under "Optional Accessories." Minimums or additional yardage may be required. Please contact the vendor directly for specific information.

Extended lead times may be necessary for this service.

Contact your Steelcase Solutions Fulfillment Team Representative at 1.888.STEELCASE (1.888.783.3522) or send an e-mail to lineone@steelcase.com.

Resources

Collaboration Brochure
Form number S11078

Chairs for People at Work
Form number S11347

Quick Ship Guide

Collaboration Guest Chairs

SIN 711.18



Tip: Wood finishes applied to beech will match the color of stains applied to oak, walnut, or cherry but will not have the same natural grain.

Standard Includes	Required to Specify
<ul style="list-style-type: none"> ▶ Need help? Product details, page 404 • Frame: European Beech • Upholstery on seat and back: fabric price group 1 • Inserts, if selected: upholstery or European Beech • Glides: stainless steel only 	<ol style="list-style-type: none"> 1 Style number 2 Fabric color number for upholstery 3 Wood color number for frame 4 Wood color number for inserts, if selected 5 Options, if selected (see below) <ul style="list-style-type: none"> ▶ See <i>Surface Materials</i>, page 432.

Options	Price	Required to Specify
Surface Materials		
Upholstery on seat and back		
• Fabric price group 1	No cost	Specify fabric color number.
• Fabric price group 2	+\$ 26	Specify fabric color number.
• Fabric price group 3	+\$ 54	Specify fabric color number.
• Fabric price group 4	+\$ 85	Specify fabric color number.
• Fabric price group 5	+\$121	Specify fabric color number.
• Fabric price group 6	+\$175	Specify fabric color number.
• Fabric price group 7	+\$207	Specify fabric color number.
• Fabric price group 8	+\$304	Specify fabric color number.
• Fabric price group 9	+\$390	Specify fabric color number.
• Fabric price group 10	+\$476	Specify fabric color number.
• Leather price group	+\$456	Specify leather color number.
• Customer's Own Material (COM)	+\$ 33	▶ See <i>Surface Materials Reference Manual</i> .
• Customer's Own Leather (COL)	+\$ 33	▶ See <i>Surface Materials Reference Manual</i> .

Contrasting upholstery on seat and back

• Contrasting fabrics	+\$ 31	Add suffix K to the style number and specify fabric color numbers.
-----------------------	--------	---

Contrasting upholstery on seat

• Fabric price group 1	No cost	Specify fabric color number.
• Fabric price group 2	+\$ 13	Specify fabric color number.
• Fabric price group 3	+\$ 27	Specify fabric color number.
• Fabric price group 4	+\$ 42	Specify fabric color number.
• Fabric price group 5	+\$ 60	Specify fabric color number.
• Fabric price group 6	+\$ 87	Specify fabric color number.
• Fabric price group 7	+\$103	Specify fabric color number.
• Fabric price group 8	+\$152	Specify fabric color number.
• Fabric price group 9	+\$195	Specify fabric color number.
• Fabric price group 10	+\$238	Specify fabric color number.
• Leather price group	+\$243	Specify leather color number.
• Customer's Own Material (COM)	+\$ 16	▶ See <i>Surface Materials Reference Manual</i> .
• Customer's Own Leather (COL)	+\$ 16	▶ See <i>Surface Materials Reference Manual</i> .

Contrasting upholstery on back

• Fabric price group 1	No cost	Specify fabric color number.
• Fabric price group 2	+\$ 12	Specify fabric color number.
• Fabric price group 3	+\$ 27	Specify fabric color number.
• Fabric price group 4	+\$ 43	Specify fabric color number.
• Fabric price group 5	+\$ 61	Specify fabric color number.
• Fabric price group 6	+\$ 88	Specify fabric color number.
• Fabric price group 7	+\$104	Specify fabric color number.
• Fabric price group 8	+\$152	Specify fabric color number.
• Fabric price group 9	+\$195	Specify fabric color number.
• Fabric price group 10	+\$238	Specify fabric color number.
• Leather price group	+\$244	Specify leather color number.
• Customer's Own Material (COM)	+\$ 17	▶ See <i>Surface Materials Reference Manual</i> .
• Customer's Own Leather (COL)	+\$ 17	▶ See <i>Surface Materials Reference Manual</i> .

Soil-retardant treatment

	+\$ 25	Specify with soil-retardant treatment.
--	--------	--

Frame

• Customiz stain on wood	No cost	Specify with Customiz stain. ▶ See <i>Surface Materials Reference Manual</i> .
--------------------------	---------	---

Specification Information

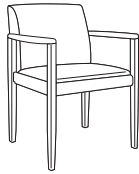

Open



Description	Style Number	Base Price
Wood arms	120	\$ 925

Arcade Insert



Description	Style Number	Base Price
Wood arms	120D	\$1025

Ladder Insert



Description	Style Number	Base Price
Wood arms	120L	\$1025

Upholstered Insert



Description	Style Number	Base Price
Wood arms	120U	\$1025



Mingle

Mingle guest chairs, designed by Bill Schacht and Lynda Chesser, have a tailored appearance that is sophisticated and pure in design, yet simple in scale. Mingle's design addresses a broad set of applications from an open plan systems environment to a closed office setting.

Exposed maple plywood back panel provides enhanced lumbar support to achieve a high level of comfort.

Upholstered seat features a webbed-panel construction.

Back legs and seat frame are metal for additional strength and durability. Legs are standard in black. Nickel powder-coat is available as an option.

Foot cap is standard with nickel finish.

Arms taper to flow into front legs.

Glides are 1/2" diameter on front legs and 1" diameter on back legs.

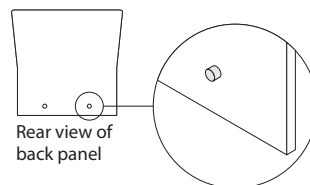
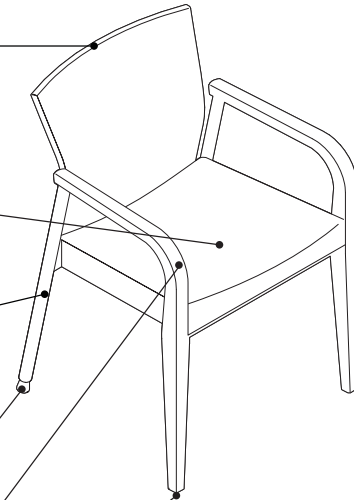

Rear view of back panel

Metal button fasteners located at bottom of back panel secure seat and back attachment while providing an additional element of design.

Surface Materials

Seat

- Fabric
- Fabric with soil-retardant treatment (option)
- Leather
- COM
- COL

Back legs

- Black
- Nickel (option)

Back, arms, and front legs

- Maple plywood
- Customiz stain (option)

Metal button fasteners

- Nickel color only

Foot caps on back legs

- Nickel color only

Glides

- Stainless steel on front legs
- Nylon on back legs

All Steelcase seating with standard upholstery fabrics

complies with requirements of the State of California Technical Bulletin 117-2013. All standard seating is labeled to be in compliance with California 117-2013.

Actual Dimensions

Overall depth	22 ¹ / ₈ "
Overall width	22 ¹ / ₄ "
Overall height	32"
Seat depth	17 ¹ / ₂ "
Seat width	17 ⁷ / ₈ "
Back width	17 ¹ / ₄ "
Back height	14"
Width between arms	19"
Seat to floor height	17 ¹ / ₂ "
Arm height from floor	25 ¹ / ₂ "

Programs & Services

► See the *Surface Materials Reference Manual* for further detail about programs and services offered for seating.

The Customer's Own Material (COM & COL)

Program offers the opportunity for customers to select fabrics and leather that are not offered through the standard Steelcase surface materials program for use on Steelcase products. Avoid pattern fabrics and heavily grained leathers. Through the COM & COL program, Steelcase will test your materials for application on Steelcase products. Once approved, you can place your order. Steelcase will facilitate the entire ordering process and give you a production schedule. Steelcase will order the COM & COL fabric and leather directly from the textile manufacturer. For up-to-date information regarding fabric test results for all COM & COL fabrics and details regarding yardage requirements for most Seating lines, visit the COM website. To locate the COM website:

- Visit www.steelcase.com

Soil retardants are treatments that provide long-term soil and stain resistance to a fabric without affecting the shade or the integrity of the fabric. The following Steelcase Textiles are available pre-treated with soil retardant. (You do not need to select the soil-retardant option for these fabrics and incur the upcharge.)

- Jacks
- Link
- Spyder

For information on soil retardant fabrics on Select Surfaces, please refer to the *Surface Materials Reference Manual*.

Soil-retardant treatment is available on all other seating fabrics at an additional upcharge per seating unit. To order this option, please select "Soil-Retardant Treatment" under "Optional Accessories."

For soil-retardant treatment on COMs, please select "Soil-Retardant Treatment" under "Optional Accessories." Minimums or additional yardage may be required. Please contact the vendor directly for specific information.

Extended lead times may be necessary for this service.

Contact your Steelcase Solutions Fulfillment Team Representative at 1.888.STEELCASE (1.888.783.3522) or send an e-mail to lineone@steelcase.com.

Resources

Mingle Brochure
Form number S10880

Mingle Guest Chair

SIN 711.18



Standard Includes	Required to Specify
<ul style="list-style-type: none"> ▶ Need help? Product details, page 408 • Back, arms, and front legs: maple • Back legs: black • Upholstery: fabric price group 1 • Glides: stainless steel on front legs, nylon on back legs 	<ol style="list-style-type: none"> 1 Style number 2 Wood color number for frame 3 Fabric color number for upholstery 4 Options, if selected (see below) <p>▶ See <i>Surface Materials</i>, page 432.</p>

Options	Price	Required to Specify
<p>Surface Materials</p> <p>Upholstery</p> <ul style="list-style-type: none"> • Fabric price group 1 • Fabric price group 2 • Fabric price group 3 • Fabric price group 4 • Fabric price group 5 • Fabric price group 6 • Fabric price group 7 • Fabric price group 8 • Fabric price group 9 • Fabric price group 10 • Leather price group • Customer's Own Material (COM) • Customer's Own Leather (COL) 	<ul style="list-style-type: none"> No cost +\$ 26 +\$ 54 +\$ 85 +\$106 +\$121 +\$153 +\$196 +\$243 +\$318 +\$243 +\$ 16 +\$ 16 	<ul style="list-style-type: none"> Specify fabric color number. Specify fabric color number. Specify fabric color number. Specify fabric color number. Specify fabric color number. Specify fabric color number. Specify fabric color number. Specify fabric color number. Specify fabric color number. Specify fabric color number. Specify leather color number. <p>▶ See <i>Surface Materials Reference Manual</i>.</p> <p>▶ See <i>Surface Materials Reference Manual</i>.</p>
<p>Soil-retardant treatment</p>	<p>+\$ 25</p>	<p>Specify <i>with soil-retardant treatment</i>.</p>
<p>Frame</p> <ul style="list-style-type: none"> • Customiz stain on wood 	<p>No cost</p>	<p>Specify <i>with Customiz stain</i>.</p> <p>▶ See <i>Surface Materials Reference Manual</i>.</p>
<p>Legs</p> <ul style="list-style-type: none"> • Nickel 	<p>+\$ 30</p>	<p>Specify <i>with 7026 Nickel</i>.</p>

Specification Information	
Style Number	Base Price
MNGLB	\$1059

SIN 711.18

Nooi by Weisner Hager

The Nooi collection, designed by Wiesner Hager, is multi-use chairs and stools that can also stack. Nooi's sophisticated design and versatile statement of line provides choice and control in a broad range of spaces.

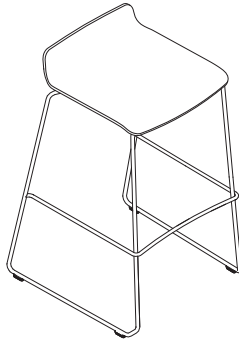

Arms are available on select styles.

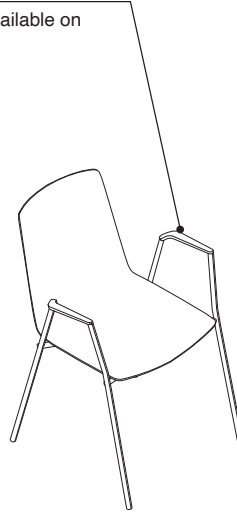

Seat and back are one integrated plastic shell. The interior shell is textured, while the exterior shell is high gloss, enhancing the product design. Available with a plastic seat and back, upholstery on seat and plastic back, or upholstery on seat and back on select styles.

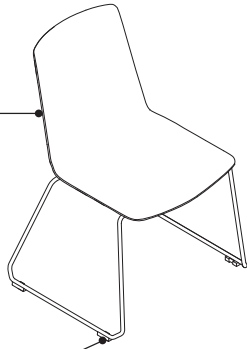

Glides are available in hard and soft options.

Ganging device integrated into select frame styles creates an ingenious interlocking frame system that supports simplistic reconfigurability.

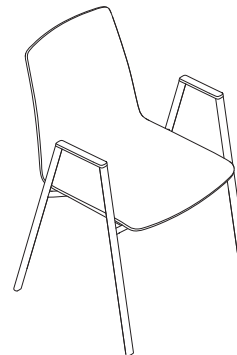
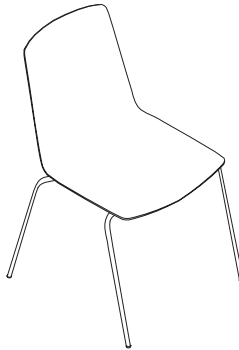

Product Details

Stackability varies by style number. See specific style number product page for details.

Hard glides are required for carpeted surfaces and soft glides are required for non-carpeted surfaces.

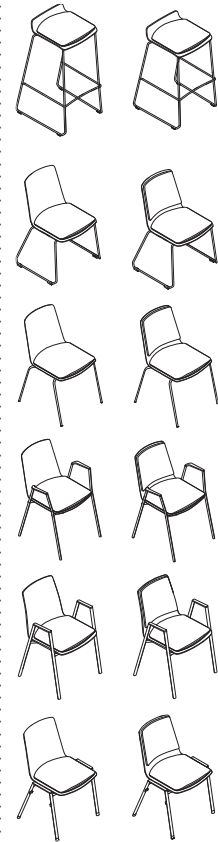

Nooi is available with a plastic seat and back, upholstery on seat and plastic back, or upholstery on seat and back on select styles.

Surface Materials

▶ See *Surface Materials Reference Manual* for specific availability

Frame

- 0835 Black
- 4242 Milk
- 4799 Platinum Metallic
- 4H04 Chrome

Arm pad cover

- WH95 Black
- WH96 White

Frame cover

- WH95 Black
- WH96 White

Shell

- WH69 White/Light Green
- WH71 White/Mocca Anthracite
- WH72 Black/Black
- WH73 White/White
- WH74 Mocca Anthracite/Mocca Anthracite
- WH75 White/Light Blue
- WH76 White/Yellow
- WH77 White/Terra
- WH78 White/Warm Grey
- WH79 White/Black

Tip: The first color listed for each finish number represents the interior textured shell color. The color listed after the backslash for each finish number represents the exterior high-gloss shell color.

Upholstery

- Fabric
- Fabric with soil retardant treatment (option)
- Leather
- Elmosoft leather
- Select Surfaces leather
- Vinyl

Glides

- Hard glides are required for carpeted surfaces and soft glides are required for non-carpeted surfaces.

All Steelcase seating with standard upholstery fabrics complies with requirements of the State of California Technical Bulletin 117-2013. All standard seating is labeled to be in compliance with California 117-2013.

Programs & Services

▶ See the *Surface Materials Reference Manual* for further detail about programs and services offered for seating.

Select Surfaces

For information on products within Select Surfaces

including accent paints, Signature plastics, and fabrics from Designtex, Gabriel, Kvadrat, and Pollack, please refer to the *Surface Materials Reference Manual* or visit www.steelcase.com/selectsurfaces.

Custom Surfaces

The Customer's Own Material (COM)

Program offers the opportunity for customers to select fabrics that are not offered through the standard Steelcase surface materials program for use on Steelcase products. Through the COM program, Steelcase will test your materials for application on Steelcase products. Once approved, you can place your order. Steelcase will facilitate the entire ordering process and give you a production schedule. Steelcase will order the COM fabric directly from the textile manufacturer. For up-to-date information regarding fabric test results for all COM fabrics and details regarding yardage requirements for most Seating lines, visit the COM website. To locate the COM website:

- Visit www.steelcase.com

Soil retardants are treatments that provide long-term soil and stain resistance to a fabric without affecting the shade or the integrity of the fabric. The following Steelcase Textiles are available pre-treated with soil retardant. (You do not need to select the soil-retardant option for these fabrics and incur the upcharge.)

- Jacks
- Link
- Spyder

For information on soil retardant fabrics on Select Surfaces, please refer to the *Surface Materials Reference Manual*.

Soil-retardant treatment is available on all other seating fabrics at an additional upcharge per seating unit. To order this option, please select "Soil-Retardant Treatment" under "Optional Accessories."

For soil-retardant treatment on COMs, please select "Soil-Retardant Treatment" under "Optional Accessories." Minimums or additional yardage may be required. Please contact the vendor directly for specific information.

Extended lead times may be necessary for this service.

Contact your Steelcase Solutions Fulfillment Team Representative at 1.888.STEELCASE (1.888.783.3522) or send an email to lineone@steelcase.com.

Local codes may have special requirements for upholstery.

Dimensions

▶ Page 414

Resources

Printed Materials

▶ Nooi Brochure (18-0006442)

Online Resources

▶ Environmental profiles available on www.steelcase.com/sustainability.

Dimensions

Nooi by Wiesner Hager

• Features	• Overall Depth	• Width	• Height	• Stacking Height	• Footrest Height	• Seat Depth	• Functional Seat Depth	• Seat Width
Nooi by Wiesner Hager								
Frame Linking Chair, Armless	22 ¹ / ₂ "	21"	33 ¹ / ₂ "	67 ⁷ / ₁₀ "	N.A.	17 ³ / ₁₀ "	17 ³ / ₁₀ "	18"
Frame Linking Chair with Arms	22 ¹ / ₂ "	21"	33 ¹ / ₂ "	75 ⁹ / ₁₀ "	N.A.	17 ³ / ₁₀ "	17 ³ / ₁₀ "	18"
Sled-Base Chair	22 ⁴ / ₅ "	22 ⁹ / ₁₀ "	33"	43 ¹ / ₁₀ "	N.A.	17 ³ / ₁₀ "	17 ³ / ₁₀ "	18 ¹ / ₁₀ "
Cafeteria Chair, Armless	22 ⁴ / ₅ "	22 ⁹ / ₁₀ "	33"	46 ⁴ / ₅ "	N.A.	17 ³ / ₁₀ "	17 ³ / ₁₀ "	18 ¹ / ₁₀ "
Cafeteria Chair with Arms	22 ⁴ / ₅ "	22 ⁹ / ₁₀ "	33"	46 ⁴ / ₅ "	N.A.	17 ³ / ₁₀ "	17 ³ / ₁₀ "	18 ¹ / ₁₀ "
Bar-Height Stool	21 ¹ / ₂ "	20 ¹ / ₂ "	33 ³ / ₁₀ "	40 ² / ₅ "	12 ⁴ / ₅ "	17 ³ / ₁₀ "	17 ³ / ₁₀ "	17 ¹ / ₁₀ "
Café-Height Stool	20 ³ / ₁₀ "	20 ³ / ₁₀ "	29"	36 ⁹ / ₁₀ "	8 ⁷ / ₁₀ "	17 ³ / ₁₀ "	17 ³ / ₁₀ "	17 ¹ / ₁₀ "
:	:	:	:	:	:	:	:	:

• Seat Height • from Floor	• Back • Width	• Back Height • from Seat	• Width • Between • Arms	• Arm to Floor	• Arm Height • from Seat	• Seat • Pan Angle	• Angle Between • Seat and Back
17 ¹ / ₂ "	15 ¹ / ₁₀ "	17 ³ / ₅ "	N.A.	N.A.	N.A.	27 ¹ / ₁₀ °	103 ² / ₅ °
17 ¹ / ₂ "	15 ¹ / ₁₀ "	17 ³ / ₅ "	18 ⁹ / ₁₀ "	26 ³ / ₅ "	8 ² / ₅ "	24 ⁴ / ₅ °	103 ¹ / ₂ °
17 ¹ / ₂ "	15 ¹ / ₁₀ "	17 ³ / ₅ "	N.A.	N.A.	N.A.	-1 ⁵ / ₅ °	102 ¹ / ₁₀ °
17 ¹ / ₂ "	15 ¹ / ₁₀ "	17 ³ / ₅ "	N.A.	N.A.	N.A.	3 ² / ₅ °	102 ¹ / ₂ °
17 ¹ / ₂ "	15 ¹ / ₁₀ "	17 ³ / ₅ "	18 ¹ / ₂ "	26 ⁴ / ₅ "	8 ⁹ / ₁₀ "	37 ¹ / ₁₀ °	103°
29 ⁴ / ₅ "	15 ² / ₅ "	3 ³ / ₅ "	N.A.	N.A.	N.A.	19 ¹ / ₁₀ °	100 ⁹ / ₁₀ °
25 ³ / ₅ "	15 ² / ₅ "	3 ³ / ₅ "	N.A.	N.A.	N.A.	19 ¹ / ₁₀ °	100 ⁹ / ₁₀ °
:	:	:	:	:	:	:	:

Nooi Frame Linking Chairs by Wiesner Hager

SIN 711.18



Tip: The first color indicates the interior, textured shell color. The color after the backslash indicates the exterior, high-gloss shell color.

Standard Includes	Required to Specify
<ul style="list-style-type: none"> ▶ Need help? Product details, page 412 • Shell: plastic price group 1 • Seat and back: plastic to match shell • Frame color: paint price group 1 • Frame cover, if armless chair is selected: plastic price group 1 • Arm pad cover, if chair with arms is selected: plastic price group 1 	<ol style="list-style-type: none"> 1 Style number 2 Plastic color number for shell 3 Paint color number for frame 4 Plastic color number for frame cover, if selected 5 Plastic color number for arm pad cover, if selected 6 Options, if selected (see below) <p>▶ See <i>Surface Materials</i>, page 432.</p>

Surface Materials	Options	Price	Required to Specify
	Upholstery version		
	<ul style="list-style-type: none"> • Upholstered seat and plastic back +\$130 • Upholstered seat and back +\$260 		<p>Specify with <i>upholstered seat and plastic back</i>.</p> <p>Specify with <i>upholstered seat and back</i>.</p>
	Shell		
	<ul style="list-style-type: none"> • WH69 White/Light Green No cost • WH71 White/Mocca Anthracite No cost • WH72 Black/Black No cost • WH73 White/White No cost • WH74 Mocca Anthracite/Mocca Anthracite No cost • WH75 White/Light Blue No cost • WH76 White/Yellow No cost • WH77 White/Terra No cost • WH78 White/Warm Grey No cost • WH79 White/Black No cost 		<p>Specify with <i>WH69 White/Light Green</i>.</p> <p>Specify with <i>WG71 White/Mocca Anthracite</i>.</p> <p>Specify with <i>WH72 Black/Black</i>.</p> <p>Specify with <i>WH73 White/White</i>.</p> <p>Specify with <i>WH74 Mocca Anthracite/Mocca Anthracite</i>.</p> <p>Specify with <i>WH75 White/Light Blue</i>.</p> <p>Specify with <i>WH76 White/Yellow</i>.</p> <p>Specify with <i>WH77 White/Terra</i>.</p> <p>Specify with <i>WH78 White/Warm Grey</i>.</p> <p>Specify with <i>WH79 White/Black</i>.</p>
	Upholstery on seat		
	<ul style="list-style-type: none"> • Fabric price group 1 No cost • Fabric price group 2 +\$ 14 • Fabric price group 3 +\$ 25 • Fabric price group 4 +\$ 36 • Fabric price group 5 +\$ 45 • Fabric price group 6 +\$ 64 • Fabric price group 7 +\$ 90 • Fabric price group 8 +\$119 • Fabric price group 9 +\$141 • Fabric price group 10 +\$164 • Steelcase leather upholstery +\$ 93 • Select Surfaces leather price group 1 +\$ 93 • Elmosoft leather upholstery +\$108 • Select Surfaces leather price group 2 +\$108 • Customer's Own Material/Vinyl (COM) No cost • Customer's Own Leather (COL) No cost 		<p>Specify fabric color number.</p> <p>Specify fabric color number.</p> <p>Specify fabric color number.</p> <p>Specify fabric color number.</p> <p>Specify fabric color number.</p> <p>Specify fabric color number.</p> <p>Specify fabric color number.</p> <p>Specify fabric color number.</p> <p>Specify fabric color number.</p> <p>Specify fabric color number.</p> <p>Specify fabric color number.</p> <p>Specify leather color number.</p> <p>▶ See <i>Surface Materials Reference Manual</i>.</p> <p>Specify Elmosoft leather color number.</p> <p>▶ See <i>Surface Materials Reference Manual</i>.</p> <p>▶ See <i>Surface Materials Reference Manual</i>.</p> <p>Specify leather color number.</p>

▶ Options, continued on next page

SIN 711.18

► Options, continued from previous page

Options	Price	Required to Specify
Surface Materials, continued		
Upholstery on back		
• Fabric price group 1	No cost	Specify fabric color number.
• Fabric price group 2	+\$ 14	Specify fabric color number.
• Fabric price group 3	+\$ 25	Specify fabric color number.
• Fabric price group 4	+\$ 36	Specify fabric color number.
• Fabric price group 5	+\$ 45	Specify fabric color number.
• Fabric price group 6	+\$ 64	Specify fabric color number.
• Fabric price group 7	+\$ 90	Specify fabric color number.
• Fabric price group 8	+\$119	Specify fabric color number.
• Fabric price group 9	+\$141	Specify fabric color number.
• Fabric price group 10	+\$164	Specify fabric color number.
• Steelcase leather upholstery	+\$ 93	Specify leather color number.
• Select Surfaces leather price group 1	+\$ 93	► See <i>Surface Materials Reference Manual</i> .
• Elmosoft leather upholstery	+\$108	Specify Elmosoft leather color number.
• Select Surfaces leather price group 2	+\$108	► See <i>Surface Materials Reference Manual</i> .
• Customer's Own Material/Vinyl (COM)	No cost	► See <i>Surface Materials Reference Manual</i> .
• Customer's Own Leather (COL)	No cost	Specify leather color number.
Contrasting upholstery on seat and back		
• Contrasting fabrics	+\$ 31	Specify with <i>contrasting</i> .
Soil-retardant treatment	+\$ 28	Specify with <i>soil-retardant treatment</i> .
Frame color on WHG6600		
• 4242 Milk	No cost	Specify with <i>4242 Milk</i> .
• 0835 Black	+\$ 15	Specify with <i>0835 Black</i> .
• 4799 Platinum Metallic	+\$ 15	Specify with <i>4799 Platinum Metallic</i> .
• WH04 Chrome	+\$ 50	Specify with <i>WH04 Chrome</i> .
Frame color on WHG6602		
• 4242 Milk	No cost	Specify with <i>4242 Milk</i> .
• 0835 Black	+\$ 15	Specify with <i>0835 Black</i> .
• 4799 Platinum Metallic	+\$ 15	Specify with <i>4799 Platinum Metallic</i> .
• WH04 Chrome	+\$ 75	Specify with <i>WH04 Chrome</i> .
Frame cover on WHG6600		
• WH95 Black	No cost	Specify with <i>WH95 Black</i> .
• WH96 White	No cost	Specify with <i>WH96 White</i> .
Arm pad cover on WHG6602		
• WH95 Black	No cost	Specify with <i>WH95 Black</i> .
• WH96 white	No cost	Specify with <i>WH96 White</i> .
Glides		
• Hard	No cost	Specify with <i>hard glides</i> .
• Soft	No cost	Specify with <i>soft glides</i> .

Tip: Hard glides are required for carpeted surfaces and soft glides are required for non-carpeted surfaces.



Specification Information

Style Number	Base Price
--------------	------------

Frame Linking Chair, Armless

WHG6600	\$500
---------	-------

Frame Linking Chair with Arms

WHG6602	\$550
---------	-------

Nooi Sled-Base Chair by Wiesner Hager

SIN 711.18



Tip: The first color indicates the interior, textured shell color. The color after the backslash indicates the exterior, high-gloss shell color.

Standard Includes		Required to Specify	
<ul style="list-style-type: none"> ▶ Need help? Product details, page 412 	<ul style="list-style-type: none"> • Shell: plastic price group 1 • Seat and back: plastic to match shell • Frame color: paint price group 1 	<ol style="list-style-type: none"> 1 Style number 2 Plastic color number for shell 3 Paint color number for frame 4 Options, if selected (see below) <ul style="list-style-type: none"> ▶ See <i>Surface Materials</i>, page 432. 	
Surface Materials	Options	Price	Required to Specify
	Upholstery version		
	<ul style="list-style-type: none"> • Upholstered seat and plastic back • Upholstered seat and back 	<ul style="list-style-type: none"> + \$130 + \$260 	<ul style="list-style-type: none"> Specify with <i>upholstered seat and plastic back</i>. Specify with <i>upholstered seat and back</i>.
	Shell		
	<ul style="list-style-type: none"> • WH69 White/Light Green • WH71 White/Mocca Anthracite • WH72 Black/Black • WH73 White/White • WH74 Mocca Anthracite/Mocca Anthracite • WH75 White/Light Blue • WH76 White/Yellow • WH77 White/Terra • WH78 White/Warm Grey • WH79 White/Black 	<ul style="list-style-type: none"> No cost No cost No cost No cost No cost No cost No cost No cost No cost No cost 	<ul style="list-style-type: none"> Specify with <i>WH69 White/Light Green</i>. Specify with <i>WG71 White/Mocca Anthracite</i>. Specify with <i>WH72 Black/Black</i>. Specify with <i>WH73 White/White</i>. Specify with <i>WH74 Mocca Anthracite/Mocca Anthracite</i>. Specify with <i>WH75 White/Light Blue</i>. Specify with <i>WH76 White/Yellow</i>. Specify with <i>WH77 White/Terra</i>. Specify with <i>WH78 White/Warm Grey</i>. Specify with <i>WH79 White/Black</i>.
	Upholstery on seat		
	<ul style="list-style-type: none"> • Fabric price group 1 • Fabric price group 2 • Fabric price group 3 • Fabric price group 4 • Fabric price group 5 • Fabric price group 6 • Fabric price group 7 • Fabric price group 8 • Fabric price group 9 • Fabric price group 10 • Steelcase leather upholstery • Select Surfaces leather price group 1 • Elmosoft leather upholstery • Select Surfaces leather price group 2 • Customer's Own Material/Vinyl (COM) • Customer's Own Leather (COL) 	<ul style="list-style-type: none"> No cost + \$ 14 + \$ 25 + \$ 36 + \$ 45 + \$ 64 + \$ 90 + \$119 + \$141 + \$164 + \$ 93 + \$ 93 + \$108 + \$108 No cost No cost 	<ul style="list-style-type: none"> Specify fabric color number. Specify fabric color number. Specify fabric color number. Specify fabric color number. Specify fabric color number. Specify fabric color number. Specify fabric color number. Specify fabric color number. Specify fabric color number. Specify fabric color number. Specify leather color number. ▶ See <i>Surface Materials Reference Manual</i>. Specify Elmosoft leather color number. ▶ See <i>Surface Materials Reference Manual</i>. ▶ See <i>Surface Materials Reference Manual</i>. Specify leather color number.
	Upholstery on back		
	<ul style="list-style-type: none"> • Fabric price group 1 • Fabric price group 2 • Fabric price group 3 • Fabric price group 4 • Fabric price group 5 • Fabric price group 6 • Fabric price group 7 • Fabric price group 8 • Fabric price group 9 • Fabric price group 10 • Steelcase leather upholstery • Select Surfaces leather price group 1 • Elmosoft leather upholstery • Select Surfaces leather price group 2 • Customer's Own Material/Vinyl (COM) • Customer's Own Leather (COL) 	<ul style="list-style-type: none"> No cost + \$ 14 + \$ 25 + \$ 36 + \$ 45 + \$ 64 + \$ 90 + \$119 + \$141 + \$164 + \$ 93 + \$ 93 + \$108 + \$108 No cost No cost 	<ul style="list-style-type: none"> Specify fabric color number. Specify fabric color number. Specify fabric color number. Specify fabric color number. Specify fabric color number. Specify fabric color number. Specify fabric color number. Specify fabric color number. Specify fabric color number. Specify fabric color number. Specify leather color number. ▶ See <i>Surface Materials Reference Manual</i>. Specify Elmosoft leather color number. ▶ See <i>Surface Materials Reference Manual</i>. ▶ See <i>Surface Materials Reference Manual</i>. Specify leather color number.

▶ Options, continued on next page

SIN 711.18

► Options, continued from previous page

Options	Price	Required to Specify
Surface Materials, continued	Contrasting upholstery on seat and back	
• Contrasting fabrics	+\$31	Specify with <i>contrasting</i> .
	Soil-retardant treatment	Specify with <i>soil-retardant treatment</i> .
	Frame color	
• 4242 Milk	No cost	Specify with <i>4242 Milk</i> .
• 0835 Black	+\$15	Specify with <i>0835 Black</i> .
• 4799 Platinum Metallic	+\$15	Specify with <i>4799 Platinum Metallic</i> .
• WH04 Chrome	+\$50	Specify with <i>WH04 Chrome</i> .
Glides	• Hard	No cost
	• Soft	No cost
		Specify with <i>hard glides</i> .
		Specify with <i>soft glides</i> .

Tip: Hard glides are required for carpeted surfaces and soft glides are required for non-carpeted surfaces.



Specification Information

Style Number	Base Price
WHG6604	\$450

Nooi Cafeteria Chairs by Wiesner Hager

SIN 711.18



Tip: The first color indicates the interior, textured shell color. The color after the backslash indicates the exterior, high-gloss shell color.

Standard Includes	Required to Specify
<ul style="list-style-type: none"> ▶ Need help? Product details, page 412 • Shell: plastic price group 1 • Seat and back: plastic to match shell • Frame color: paint price group 1 • Arm pad cover, if chair with arms is selected: plastic price group 1 	<ol style="list-style-type: none"> 1 Style number 2 Plastic color number for shell 3 Paint color number for frame 4 Plastic color number for arm pad cover, if selected 5 Options, if selected (see below) <p>▶ See <i>Surface Materials</i>, page 432.</p>

Surface Materials	Options	Price	Required to Specify
	<p>Upholstery version</p> <ul style="list-style-type: none"> • Upholstered seat and plastic back +\$130 • Upholstered seat and back +\$260 		<p>Specify with <i>upholstered seat and plastic back</i>.</p> <p>Specify with <i>upholstered seat and back</i>.</p>
	<p>Shell</p> <ul style="list-style-type: none"> • WH69 White/Light Green No cost • WH71 White/Mocca Anthracite No cost • WH72 Black/Black No cost • WH73 White/White No cost • WH74 Mocca Anthracite/Mocca Anthracite No cost • WH75 White/Light Blue No cost • WH76 White/Yellow No cost • WH77 White/Terra No cost • WH78 White/Warm Grey No cost • WH79 White/Black No cost 		<p>Specify with <i>WH69 White/Light Green</i>.</p> <p>Specify with <i>WG71 White/Mocca Anthracite</i>.</p> <p>Specify with <i>WH72 Black/Black</i>.</p> <p>Specify with <i>WH73 White/White</i>.</p> <p>Specify with <i>WH74 Mocca Anthracite/Mocca Anthracite</i>.</p> <p>Specify with <i>WH75 White/Light Blue</i>.</p> <p>Specify with <i>WH76 White/Yellow</i>.</p> <p>Specify with <i>WH77 White/Terra</i>.</p> <p>Specify with <i>WH78 White/Warm Grey</i>.</p> <p>Specify with <i>WH79 White/Black</i>.</p>
	<p>Upholstery on seat</p> <ul style="list-style-type: none"> • Fabric price group 1 No cost • Fabric price group 2 +\$ 14 • Fabric price group 3 +\$ 25 • Fabric price group 4 +\$ 36 • Fabric price group 5 +\$ 45 • Fabric price group 6 +\$ 64 • Fabric price group 7 +\$ 90 • Fabric price group 8 +\$119 • Fabric price group 9 +\$141 • Fabric price group 10 +\$164 • Steelcase leather upholstery +\$ 93 • Select Surfaces leather price group 1 +\$ 93 • Elmosoft leather upholstery +\$108 • Select Surfaces leather price group 2 +\$108 • Customer's Own Material/Vinyl (COM) No cost • Customer's Own Leather (COL) No cost 		<p>Specify fabric color number.</p> <p>Specify fabric color number.</p> <p>Specify fabric color number.</p> <p>Specify fabric color number.</p> <p>Specify fabric color number.</p> <p>Specify fabric color number.</p> <p>Specify fabric color number.</p> <p>Specify fabric color number.</p> <p>Specify fabric color number.</p> <p>Specify fabric color number.</p> <p>Specify leather color number.</p> <p>▶ See <i>Surface Materials Reference Manual</i>. Specify Elmosoft leather color number.</p> <p>▶ See <i>Surface Materials Reference Manual</i>.</p> <p>▶ See <i>Surface Materials Reference Manual</i>. Specify leather color number.</p>
	<p>Upholstery on back</p> <ul style="list-style-type: none"> • Fabric price group 1 No cost • Fabric price group 2 +\$ 14 • Fabric price group 3 +\$ 25 • Fabric price group 4 +\$ 36 • Fabric price group 5 +\$ 45 • Fabric price group 6 +\$ 64 • Fabric price group 7 +\$ 90 • Fabric price group 8 +\$119 • Fabric price group 9 +\$141 • Fabric price group 10 +\$164 • Steelcase leather upholstery +\$ 93 • Select Surfaces leather price group 1 +\$ 93 • Elmosoft leather upholstery +\$108 • Select Surfaces leather price group 2 +\$108 • Customer's Own Material/Vinyl (COM) No cost • Customer's Own Leather (COL) No cost 		<p>Specify fabric color number.</p> <p>Specify fabric color number.</p> <p>Specify fabric color number.</p> <p>Specify fabric color number.</p> <p>Specify fabric color number.</p> <p>Specify fabric color number.</p> <p>Specify fabric color number.</p> <p>Specify fabric color number.</p> <p>Specify fabric color number.</p> <p>Specify fabric color number.</p> <p>Specify leather color number.</p> <p>▶ See <i>Surface Materials Reference Manual</i>. Specify Elmosoft leather color number.</p> <p>▶ See <i>Surface Materials Reference Manual</i>.</p> <p>▶ See <i>Surface Materials Reference Manual</i>. Specify leather color number.</p>

▶ Options, continued on next page

SIN 711.18

► Options, continued from previous page

Options	Price	Required to Specify
Surface Materials, continued	Contrasting upholstery on seat and back	
• Contrasting fabrics	+\$31	Specify with <i>contrasting</i> .
	Soil-retardant treatment	Specify with <i>soil-retardant treatment</i> .
	Frame color	
• 4242 Milk	No cost	Specify with <i>4242 Milk</i> .
• 0835 Black	+\$15	Specify with <i>0835 Black</i> .
• 4799 Platinum Metallic	+\$15	Specify with <i>4799 Platinum Metallic</i> .
• WH04 Chrome	+\$50	Specify with <i>WH04 Chrome</i> .
	Arm pad cover on WHG6608	
• WH95 Black	No cost	Specify with <i>WH95 Black</i> .
• WH96 White	No cost	Specify with <i>WH96 White</i> .
Glides	• Hard	No cost
	• Soft	No cost
		Specify with <i>hard glides</i> .
		Specify with <i>soft glides</i> .

Tip: Hard glides are required for carpeted surfaces and soft glides are required for non-carpeted surfaces.

Specification Information

Style Number	Base Price
--------------	------------

Cafeteria Chair, Armless

WHG6606 \$400



Cafeteria Chair with Arms

WHG6608 \$450



Nooi Stools by Wiesner Hager

SIN 711.18

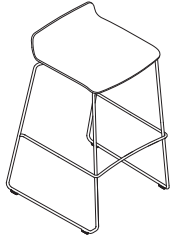

Tip: The first color indicates the interior, textured shell color. The color after the backslash indicates the exterior, high-gloss shell color.

Tip: Hard glides are required for carpeted surfaces and soft glides are required for non-carpeted surfaces.

Standard Includes	Required to Specify
-------------------	---------------------

- | | | |
|--|--|--|
| <ul style="list-style-type: none"> ▶ Need help? Product details, page 412 | <ul style="list-style-type: none"> • Shell: plastic price group 1 • Frame color: paint price group 1 | <ol style="list-style-type: none"> 1 Style number 2 Upholstery version (see below under Required Selections) 3 Plastic color number for shell 4 Paint color number for frame 5 Options, if selected (see below) <ul style="list-style-type: none"> ▶ See <i>Surface Materials</i>, page 432. |
|--|--|--|

Required Selections	Price	Required to Specify
---------------------	-------	---------------------

- | | | |
|---------------------------|--|--|
| Upholstery Version | <ul style="list-style-type: none"> • Plastic seat • Upholstered seat | <p>No cost</p> <p>+\$130</p> <p>Specify with <i>plastic seat</i>.</p> <p>Specify with <i>upholstered seat</i>.</p> |
|---------------------------|--|--|

Options	Price	Required to Specify
---------	-------	---------------------

- | | | | |
|--------------------------|---|--|---|
| Surface Materials | Shell | | |
| | <ul style="list-style-type: none"> • WH69 White/Light Green • WH71 White/Mocca Anthracite • WH72 Black/Black • WH73 White/White • WH74 Mocca Anthracite/Mocca Anthracite • WH75 White/Light Blue • WH76 White/Yellow • WH77 White/Terra • WH78 White/Warm Grey • WH79 White/Black | <p>No cost</p> <p>No cost</p> <p>No cost</p> <p>No cost</p> <p>No cost</p> <p>No cost</p> <p>No cost</p> <p>No cost</p> <p>No cost</p> <p>No cost</p> | <p>Specify with <i>WH69 White/Light Green</i>.</p> <p>Specify with <i>WG71 White/Mocca Anthracite</i>.</p> <p>Specify with <i>WH72 Black/Black</i>.</p> <p>Specify with <i>WH73 White/White</i>.</p> <p>Specify with <i>WH74 Mocca Anthracite/Mocca Anthracite</i>.</p> <p>Specify with <i>WH75 White/Light Blue</i>.</p> <p>Specify with <i>WH76 White/Yellow</i>.</p> <p>Specify with <i>WH77 White/Terra</i>.</p> <p>Specify with <i>WH78 White/Warm Grey</i>.</p> <p>Specify with <i>WH79 White/Black</i>.</p> |
| | Upholstery on seat | | |
| | <ul style="list-style-type: none"> • Fabric price group 1 • Fabric price group 2 • Fabric price group 3 • Fabric price group 4 • Fabric price group 5 • Fabric price group 6 • Fabric price group 7 • Fabric price group 8 • Fabric price group 9 • Fabric price group 10 • Steelcase leather upholstery • Select Surfaces leather price group 1 • Elmosoft leather upholstery • Select Surfaces leather price group 2 • Customer's Own Material/Vinyl (COM) • Customer's Own Leather (COL) | <p>No cost</p> <p>+\$ 14</p> <p>+\$ 25</p> <p>+\$ 36</p> <p>+\$ 45</p> <p>+\$ 64</p> <p>+\$ 90</p> <p>+\$119</p> <p>+\$141</p> <p>+\$164</p> <p>+\$ 93</p> <p>+\$ 93</p> <p>+\$108</p> <p>+\$108</p> <p>No cost</p> <p>No cost</p> | <p>Specify fabric color number.</p> <p>Specify fabric color number.</p> <p>Specify fabric color number.</p> <p>Specify fabric color number.</p> <p>Specify fabric color number.</p> <p>Specify fabric color number.</p> <p>Specify fabric color number.</p> <p>Specify fabric color number.</p> <p>Specify fabric color number.</p> <p>Specify fabric color number.</p> <p>Specify leather color number.</p> <p>▶ See <i>Surface Materials Reference Manual</i>. Specify Elmosoft leather color number.</p> <p>▶ See <i>Surface Materials Reference Manual</i>.</p> <p>▶ See <i>Surface Materials Reference Manual</i>. Specify leather color number.</p> |
| | Soil-retardant treatment | +\$ 28 | Specify with <i>soil-retardant treatment</i> . |
| | Frame color | | |
| | <ul style="list-style-type: none"> • 4242 Milk • 0835 Black • 4799 Platinum Metallic • WH04 Chrome | <p>No cost</p> <p>+\$ 15</p> <p>+\$ 15</p> <p>+\$ 75</p> | <p>Specify with <i>4242 Milk</i>.</p> <p>Specify with <i>0835 Black</i>.</p> <p>Specify with <i>4799 Platinum Metallic</i>.</p> <p>Specify with <i>WH04 Chrome</i>.</p> |

- | | | | |
|---------------|--|-------------------------------|---|
| Glides | <ul style="list-style-type: none"> • Hard • Soft | <p>No cost</p> <p>No cost</p> | <p>Specify with <i>hard glides</i>.</p> <p>Specify with <i>soft glides</i>.</p> |
|---------------|--|-------------------------------|---|

Specification Information

• Style • Number	• Base • Price
---------------------	-------------------

Bar-Height Stool

WHG6625	\$625
---------	-------

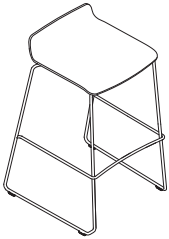

Café-Height Stool

WHG6626	\$600
---------	-------

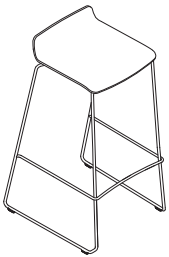

Max-Stacker III 477 Series

Max-Stacker III is a stacking chair perfect for high traffic areas. With a new texture and an updated finish offering, it fits into any environment.

Tablet arms and bookracks are available factory or field installed.

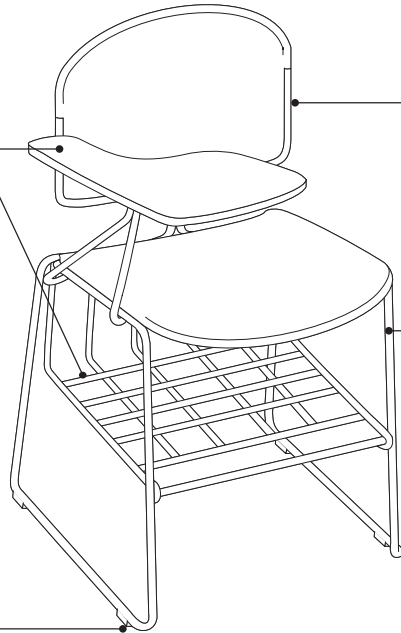

Plastic glides are standard. Soft felt glides, optional, are recommended for use on non-carpeted floors.

Back and seat are available in flexible, contoured plastic.

Two-piece wire-rod frame is 7/16" diameter carbon steel for strength and durability.

Product Details

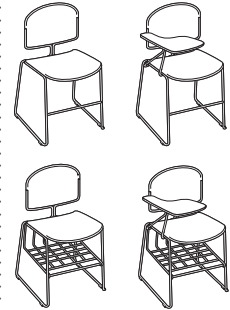

Four configurations are available—chairs without arms, chairs with bookracks, chairs with tablet arms, and chairs with a combination of bookrack and tablet arm.

Max-Stacker III can stack up to 12 chairs high when stacked on the floor.

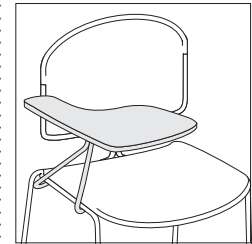

Tablet arms provide a writing surface that is 12½"D x 11⅜"W. They are available in left- or right-hand models.

Clearance between tablet arm and seat is 7¼"H. Tablet arm tilts for easy entrance and exit from chair.

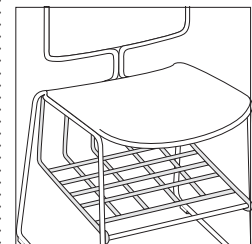

Bookrack is available factory or field installed for convenient storage of notebooks and purses.

Product Details

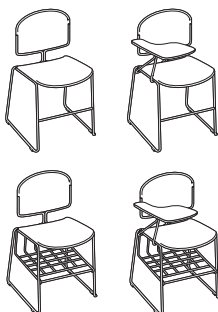

Four configurations are available—chairs without arms, chairs with bookracks, chairs with tablet arms, and chairs with a combination of bookrack and tablet arm.

Max-Stacker III can stack up to 12 chairs high when stacked on the floor.

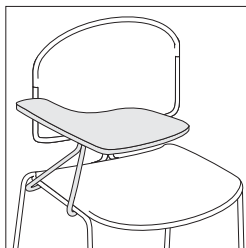

Tablet arms provide a writing surface that is 12½"D x 11⅞"W. They are available in left- or right-hand models.

Clearance between tablet arm and seat is 7¼"H. Tablet arm tilts for easy entrance and exit from chair.

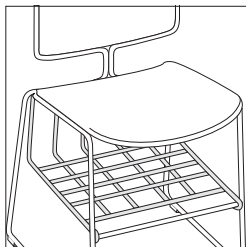

Bookrack is available factory or field installed for convenient storage of notebooks and purses.

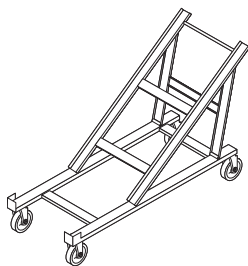

Transport and storage dolly is available to stack, move, and store up to 45 chairs. Chairs with bookracks and tablet arms cannot be stacked.

Unloaded transport dolly measures 55"D x 22"W x 37½"H.

Fully loaded transport dolly measures 57"D x 22"W x 68½"H.

Without transport dolly stack can be up to 12 chairs high.

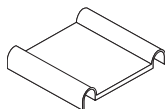

Alignment device is available to temporarily link chairs together in the field for evenly spaced rows. Chairs can be unlinked easily. Spacing between chairs linked with alignment device is 2¼".

Surface Materials

Hard components (frame)

- 4799 Platinum Metallic
- 7000 Black
- 7239 Midnight
- 9201 Polished Chrome

Lux Coatings

- 4B20 Obsidian
- 4B22 Matte Brass
- 4B23 Burnished Bronze
- 4B24 Night Bronze
- 4B25 Matte Copper
- 4B26 Smoked Mica
- 4B27 Blue Steel
- 4B28 Silver Lilac
- 4B29 Cast Iron
- 4B30 Bright Gold

Shell

Price Group 1

Plastics

- 6009 Arctic White
- 6059 Sterling Dark Solid
- 6205 Black
- 6249 Platinum Solid
- 6259 Midnight
- 6332 Citron
- 6333 Picasso
- 6334 Flash
- 6335 Wasabi
- 6336 Jazz
- 6337 Element
- 6338 Chili Red
- 6BD8 Snow
- 6BD9 Carbon Flat
- 6BE1 Ore

Price Group 2

Signature Plastics

- 6BC2 Purple
- 6BC5 Blue
- 6BC8 Gold
- 6BD1 Aubergine
- 6BD2 Peacock
- 6BD3 Jungle
- 6BD4 Merlot
- 6BD5 Honey
- 6BD6 Lagoon
- 6BD7 Saffron

Bookrack

- Coated to match the frame color on seating coated models
- 9201 Polished Chrome on Polished Chrome models
- 4B20 Obsidian
- 4B22 Matte Brass
- 4B23 Burnished Bronze
- 4B24 Night Bronze
- 4B25 Matte Copper

Tablet arms

- Laminate

Glides

- Clear plastic
- Soft

Programs & Services

▶ See the *Surface Materials Reference Manual* for further detail about programs and services offered for seating.

Dimensions

▶ Page 426

Resources

Printed Materials

▶ Max-Stacker Brochure (11-0002245)

Online Resources

▶ Environmental profiles available on www.steelcase.com/sustainability

Dimensions

Max-Stacker III 477 Series

• Features	• Overall • Depth	Width	Height	• Seat • Depth	• Functional • Seat • Depth	• Seat • Width	• Seat • Height • from • Floor	• Back • Width	• Back • Height • from • Seat	• Back • Lumbar • Height
Max-Stacker III 477 Series										
	21½"	20"	30¼"	17¾"	16¾"	18¼"	17½"	18¼"	14¾"	9½"

• Width • Between • Arms	• Arm • to • Floor	• Arm • Height • from • Seat	• Seat • Pan • Angle	• Angle • Between • Seat and • Back
--------------------------------	--------------------------	---------------------------------------	----------------------------	--

N.A.	N.A.	N.A.	8°	93°
------	------	------	----	-----

Max-Stacker III 477 Series Stackable Chair

SIN 711.19



Standard Includes	Required to Specify
<ul style="list-style-type: none"> ▶ Need help? Product details, page 424 • Frame: 7000 Black paint • Shell: plastic • Tablet arm, if selected: laminate • Bookrack, if selected: high-wear coating or 9201 Polished Chrome • Glides: plastic 	<ol style="list-style-type: none"> 1 Style number 2 Seating coating color number for frame 3 Plastic color number for shell 4 Laminate color number for tablet arm, if selected (see below under Required Selections) 5 High-wear coating or 9201 Polished Chrome for bookrack, if selected (see below under Required Selections) 6 Options, if selected (see below) <p>▶ See <i>Surface Materials</i>, page 432.</p>

Required Selections	Price	Required to Specify
Tablet <ul style="list-style-type: none"> • No tablet • Tablet left • Tablet right 	<ul style="list-style-type: none"> No cost +\$155 +\$155 	<ul style="list-style-type: none"> Specify <i>with no tablet</i>. Specify <i>with tablet arm left</i> and select laminate color number. Specify <i>with tablet arm right</i> and select laminate color number.
Bookrack <ul style="list-style-type: none"> • No bookrack • Bookrack 	<ul style="list-style-type: none"> No cost +\$ 93 	<ul style="list-style-type: none"> Specify <i>with no bookrack</i>. Specify <i>with bookrack</i> and select color number.

Options	Price	Required to Specify
Surface Materials <ul style="list-style-type: none"> • 7239 Midnight • 4799 Platinum Metallic • 9201 Polished Chrome • Lux Coatings 	<ul style="list-style-type: none"> No cost +\$ 31 +\$ 31 +\$ 59 	<ul style="list-style-type: none"> Specify <i>with 7239 Midnight</i>. Specify <i>with 4799 Platinum Metallic</i>. Specify <i>with 9201 Polished Chrome</i>. Specify Lux Coatings color number. <p>▶ See <i>Select Surfaces</i>, under <i>Surface Materials</i>, page 432.</p>
Seat shell <ul style="list-style-type: none"> • Plastic price group 1 • Plastic price group 2 	<ul style="list-style-type: none"> No cost +\$ 27 	<ul style="list-style-type: none"> Specify color number. ▶ See <i>Surface Materials</i>, page 432. Specify color number. ▶ See <i>Surface Materials</i>, page 432.
Glides <ul style="list-style-type: none"> • Soft glides for use on non-carpeted floors 	<ul style="list-style-type: none"> +\$ 6 	<ul style="list-style-type: none"> Specify <i>with soft glides</i>.

Specification Information	
Style Number	Base Price
477100	\$209

▶ Detailed dimensions, page 426

Max-Stacker III 477 Series Accessories

SIN 711.19

Tablet Arm Assembly

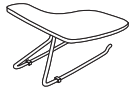

Standard Includes	Required to Specify
-------------------	---------------------

- Tablet arm frame: paint price group 1
- Tablet arm worksurface: laminate

- 1 Style number
 - 2 Laminate color number
 - 3 Paint color number for tablet arm frame
 - 4 Options, if selected (see below)
- ▶ *Surface Materials*, page 432

Surface Materials	Options	Price	Required to Specify
-------------------	---------	-------	---------------------

Surface Materials

- | Frame | Price |
|--------------------------|---------|
| • Paint price group 1 | No cost |
| • 4799 Platinum Metallic | +\$31 |
| • 9201 Polished Chrome | +\$31 |
| • Lux Coatings | +\$59 |

- Specify paint color number.
Specify *with 4799 Platinum Metallic*.
Specify *with 9201 Polished Chrome*.
Specify Lux Coatings color number.
▶ See *Select Surfaces*, under *Surface Materials*, page 432.

Specification Information	
---------------------------	--

Style Number	Base Price
--------------	------------

Right-Hand

472TAR	\$161
---------------	-------

Left-Hand

472TAL	\$161
---------------	-------

Bookrack Assembly



Standard Includes	Required to Specify
-------------------	---------------------

- Bookrack assembly: paint price group 1

- 1 Style number
 - 2 Paint color number for bookrack
 - 3 Options, if selected (see below)
- ▶ *Surface Materials*, page 432

Surface Materials	Options	Price	Required to Specify
-------------------	---------	-------	---------------------

Surface Materials

- | Frame | Price |
|--------------------------|---------|
| • Paint price group 1 | No cost |
| • 4799 Platinum Metallic | +\$31 |
| • 9201 Polished Chrome | +\$31 |
| • Lux Coatings | +\$59 |

- Specify paint color number.
Specify *with 4799 Platinum Metallic*.
Specify *with 9201 Polished Chrome*.
Specify Lux Coatings color number.
▶ See *Select Surfaces*, under *Surface Materials*, page 432.

Specification Information	
---------------------------	--

Style Number	Base Price
--------------	------------

472BR	\$97
--------------	------

Seating

Max-Stacker III 477 Series Accessories, continued

SIN 711.19

Alignment Device

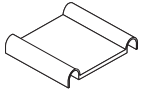

Standard Includes		Required to Specify
• Carton of 12 alignment devices: black plastic only		Style number

Specification Information	
• Style Number	• Price
472G	\$37

Transport and Storage Dolly

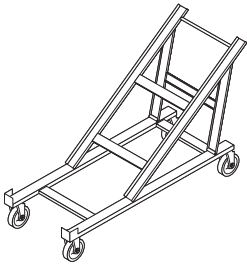

Standard Includes		Required to Specify
• Transport and storage dolly: black paint only		Style number

Specification Information	
• Style Number	• Price
473D	\$533

Surface Materials

This listing includes all the surface material choices that are available for the products in this specification guide.

Resources

For more information about surface materials, refer to the following resources:

Additional surface materials specification tools are available to assist you in the specification process—the Surface Materials Binders.

Surface Materials Binders

- Surface Materials Reference Manual
- A complete set of swatch cards for hard surfaces, vertical surface fabrics, and seating upholstery

Plastic

Steelcase Surfaces

Not every plastic color is available on every plastic component.

► Refer to the *Steel Color Availability Matrix* on pages 438–439 before specifying.

Price Group 1

Plastics

- 6009 Arctic White
- 6053 Seagull
- 6059 Sterling Dark Solid
- 6205 Black
- 6249 Platinum Solid
- 6250 Coffee
- 6256 Graphite
- 6259 Midnight
- 6296 Sterling
- 6302 Baltic
- 6332 Citron
- 6333 Picasso
- 6334 Flash
- 6335 Wasabi
- 6336 Jazz
- 6337 Element
- 6338 Chili Red
- 6421 Ash
- 6527 Merle
- 6654 Sand

- Applies to:
- Umami screen clips
- 6053 Seagull
 - 6527 Merle

Select Surfaces

Price Group 1

Plastics

- 5U22 Royal Blue
- 5U23 Blue Jay
- 5U24 Scarlet
- 5U25 Malt
- 5U26 Wasabi Too
- 5U27 Concord
- 5U28 Canary

Price Group 2

Signature Plastics

- 6BD1 Aubergine
- 6BD2 Peacock
- 6BD3 Jungle
- 6BD4 Merlot
- 6BD5 Honey
- 6BD6 Lagoon
- 6BD7 Saffron

Steelcase Surfaces

- Applies to:
- Max-Stacker III 477 Series
 - Move 490 Series
 - Node 480 Series

Price Group 1

Plastics

- 6009 Arctic White
- 6059 Sterling Dark Solid
- 6205 Black
- 6249 Platinum Solid
- 6259 Midnight
- 6332 Citron
- 6333 Picasso
- 6334 Flash
- 6335 Wasabi
- 6336 Jazz
- 6337 Element
- 6338 Chili Red
- 6BD8 Snow
- 6BD9 Carbon Flat
- 6BE1 Ore

Select Surfaces

Price Group 2

Signature Plastics

- 6BC2 Purple
- 6BC5 Blue
- 6BC8 Gold
- 6BD1 Aubergine
- 6BD2 Peacock
- 6BD3 Jungle
- 6BD4 Merlot
- 6BD5 Honey
- 6BD6 Lagoon
- 6BD7 Saffron

Seating Coating

Steelcase Surfaces

- Applies to:
- Max-Stacker III 477 Series
- 7000 Black

Paint

Steelcase Surfaces

- Available on:
- Jersey Series work chairs
- 4799 Platinum Metallic

- Available on:
- Jersey Series guest chairs
- 4799 Platinum Metallic
 - 7207 Black

- Applies to:
- Siento chairs
 - Move 490 Series chair frames
- 0835 Black
 - 4799 Platinum Metallic
 - 7239 Midnight

- Applies to:
- cobii 434 Series chairs
- 0835 Black
 - 4799 Platinum Metallic
 - 4803 Near Black Metallic

- Applies to:
- Node 480 Series chairs
- 0835 Black
 - 4750 Champagne Metallic
 - 4799 Platinum Metallic

- Applies to:
- Gesture 442 Series chairs
- 7250 Sterling Dark Solid

- Applies to:
- Think 465 Series chairs
- 4799 Platinum Metallic
 - 7243 Seagull

- Applies to:
- Brody 488 Series
- 4799 Platinum Metallic
 - 7243 Seagull
 - 7250 Sterling Dark
 - 7360 Merle

- Applies to:
- Kart
- 4138 Graphite Metallic
 - 4140 Arctic White Gloss
 - 4141 Platinum Matte
 - 4142 Platinum Gloss
 - 4144 Black Gloss
 - 4145 Milk Gloss
 - 4146 Champagne Matte
 - 4147 Champagne Gloss
 - 4148 Midnight Brown Gloss
 - 7196 Midnight Brown Texture
 - 7197 Anthracite Texture

Applies to:

- Umami
- 4144 Black Gloss
 - 4242 Milk
 - 4728 Nickel
 - 4750 Champagne Metallic
 - 4798 Sterling Metallic
 - 4799 Platinum Metallic
 - 4803 Near Black Metallic
 - 7207 Black
 - 7246 Midnight Metallic
 - 7360 Merle

Applies to:

- Brody 488 Series dash mini LED light
- 4231 Arctic White
 - 4710 Low Gloss Black
 - 4799 Platinum Metallic

Select Surfaces

Price Group 3

- Brody 488 Series dash mini LED light
- Umami

Accent paint

Accent paints allow you to choose from a pre-matched color palette of trend driven colors. Refer to the *Surface Materials Reference Manual* for more information.

Applies to:

- B-Free occasional tables
- Brody 488 Series
- Max-Stacker III 477 Series
- Move 490 Series
- QiVi 428 Series chairs (Sled base only)
- Umami

Lux Coatings

- 4B20 Obsidian
- 4B22 Matte Brass
- 4B23 Burnished Bronze
- 4B24 Night Bronze
- 4B25 Matte Copper
- 4B26 Smoked Mica
- 4B27 Blue Steel
- 4B28 Silver Lilac
- 4B29 Cast Iron
- 4B30 Bright Gold

Accessory Paint

Steelcase Surfaces

- Applies to:
- cobii 434 Series chairs
- 4140 Arctic White Gloss

Steelcase Surfaces

- Available on:
- Steel seating
- Tip: Metal colors may not be available on all seating components.*

► See *Steel Color Availability Matrix* on pages 438–439 for specification information.

- 8046 Polished Aluminum
- 9201 Polished Chrome

Available on:

- Wood seating
- 4798 Sterling
 - 7026 Nickel
 - 7207 Black
 - 9201 Polished Chrome

Laminate

Steelcase Surfaces

High-Pressure Laminate

Not every laminate color is available on every chair.

► See *Steel Color Availability Matrix* on pages 438–439 for specification information.

- 2406 Clear Cherry
- 2409 Clear Maple
- 2410 Graphite Walnut
- 2412 Natural Cherry
- 2422 Medium Cherry
- 2511 Winter on Maple
- 2538 Clear Walnut
- 2539 Warm Oak
- 2714 Natural Walnut
- 2722 Cream
- 2730 Arctic White
- 2746 Black
- 2759 Warm White
- 2772 Medium Mahogany on Walnut
- 2811 Mist
- 2883 Seagull
- 2884 Milk
- 2885 Dune
- 2HAT Acacia

Tip: Some wood veneer finishes and woodgrain laminates share the same name. Because of the difference in materials, veneers and laminates of the same name are not an exact match but do coordinate with each other.

Applies to:

- Umami round and pill table tops
- 2883 Seagull
- 2HMG Merle

Applies to:

- Brody 488 Series desks
- Umami platform
- 2406 Clear Cherry
- 2409 Clear Maple
- 2410 Graphite Walnut
- 2412 Natural Cherry
- 2422 Medium Cherry
- 2511 Winter on Maple
- 2535 Virginia Walnut
- 2536 Blackwood
- 2538 Clear Walnut
- 2539 Warm Oak
- 2592 Blonde on Maple
- 2612 Marbled Maple
- 2614 Chocolate Walnut
- 2615 Marbled Cherry V2
- 2714 Natural Walnut
- 2772 Medium Mahogany on Walnut
- 2HAK Clear Oak
- 2HAN Ash Noce
- 2HAT Acacia
- 2HAW Ash Wenge
- 2HBN Bisque Noce
- 2HBW Bisque Wenge
- 2HCN Clay Noce
- 2HCW Clay Wenge
- 2HSN Storm Noce
- 2HSW Storm Wenge

Select Surfaces

High-Pressure Laminate

Applies to:

- Brody 488 Series desks
- i2i tablet arms
- Umami platform

Textured Woodgrain Laminate

- 2TH2 Fawn Cypress
- 2TH3 Weathered Char
- 2TH4 Saddle Oak
- 2TH5 Veranda Teak
- 2TH6 Persian Cherry
- 2TH7 Walnut Heights

Textured Industrial Laminate

- 2UH1 Reclaimed Aggregate
- 2UH2 Reclaimed Gravel
- 2UH4 Cement
- 2UH6 Sheetrock

Custom Surfaces

Open Line Laminate (OLL)

Applies to:

- Brody 488 Series desks
- Umami platform

This service allows you to order non-standard laminate at an additional processing fee of \$69 per unit, plus the cost of the laminate.

High-Pressure Laminate pricing does not include premium or digitally printed patterns from any suppliers. Laminate cost may also vary for basic or standard laminates from other suppliers. Please contact the OLL consultant at 616.475.2426 for pricing. The cost of the laminate will be added to your invoice as a separate line on the acknowledgement.

When processing orders for Open Line Laminate, specify 2900 in the laminate finish field and enter the OLL manufacturer information. Enter the required edge finish as you would a standard laminate.

Laminate Approval and Material Requirements

To confirm whether a particular laminate has already been tested for use on a specific Steelcase product or to determine material square foot requirements:

- Visit www.steelcase.com

For additional information, refer to the *Steelcase Surface Materials Reference Manual*.

Wood

Applies to:

- Collaborative lounge table
- i2i tablet arm
- Snodgrass 474 Series chair frames

Steelcase Surfaces

▶ See *Wood Color Availability Matrix* on page 446 for color availability by product line.

Tip: The wood used in the construction of chairs is either maple of European beech. Wood finishes applied to maple or beech will match the color of stains applied to oak, walnut, or cherry, but will not have the same natural grain.

Open-pore finish choices

Wood Group 1

- 3062 Graphite Walnut
- 3402 Clear Cherry (Aged)
- 3412 Natural Cherry
- 3422 Medium Cherry
- 3522 Clear Maple*
- 3572 Amber on Maple
- 3592 Blonde on Maple
- 3602 Desert Oak
- 3612 Warm Oak
- 3692 Espresso Oak
- 3702 Clear Walnut
- 3712 Natural Walnut
- 3722 Dark Mahogany on Walnut
- 3752 Medium Walnut
- 3762 Dark Walnut
- 3772 Medium Mahogany on Walnut

**To ensure an understanding of the color ranges and characteristic variations of natural veneer, a sign-off sheet is required prior to orders being accepted for this clear-coat finish. The sign-off sheet is available through Steelcase advertising stock. Form number 05-0001370.*

Applies to:

- Brody 488 Series desks
- i2i tablet arms
- Umami platform

Flat-cut open-pore finish choices

Wood Group 1

- 3062 FC/OP Graphite Walnut
- 3402 FC/OP Clear Cherry (Aged)
- 3412 FC/OP Natural Cherry **E**
- 3422 FC/OP Medium Cherry
- 3522 FC/OP Clear Maple*
- 3572 FC/OP Amber on Maple **E**
- 3582 FC/OP Winter on Maple
- 3592 FC/OP Blonde on Maple
- 3702 FC/OP Clear Walnut
- 3712 FC/OP Natural Walnut
- 3722 FC/OP Dark Mahogany on Walnut
- 3752 FC/OP Medium Walnut
- 3762 FC/OP Dark Walnut
- 3772 FC/OP Medium Mahogany on Walnut

Quarter-cut open-pore finish choices

Wood Group 1

- 3042 QC/OP Ash
- 3222 QC/OP Clear Maple
- 3272 QC/OP Amber on Maple **E**
- 3292 QC/OP Blonde on Maple
- 3302 QC/OP Clear Walnut
- 3312 QC/OP Natural Walnut
- 3322 QC/OP Dark Mahogany on Walnut
- 3352 QC/OP Medium Walnut
- 3362 QC/OP Dark Walnut
- 3372 QC/OP Medium Mahogany on Walnut
- 3382 QC/OP Graphite Walnut

Rift-cut open-pore finish choices

Wood Group 1

- 3602 RC/OP Desert Oak
- 3612 RC/OP Warm Oak
- 3692 RC/OP Espresso Oak

Surface Materials, continued

Select Surfaces

Applies to:

- Brody 488 Series desks
- Umami platform
- Snodgrass 474 Series chair frames

Composite Veneer

Composite veneers are an engineered wood intended to create specific grain patterns and characteristics. They are pre-stained and finished with Steelcase's Clarity water-borne UV topcoat, which protects the environment while providing durability and clarity. Only open-pore finishes are available on composite wood. Composite veneer and matching edge bands are available on most Steelcase brand products. Composites, for use as a solid nosing substitute, are not available. Steelcase does not recommend mixing composite veneers with natural solid nosings because composite and natural wood grain and color matching are rarely compatible. Composite veneers are Graded-In as Wood Group 1 pricing.

Tip: Known for their color consistency, composite veneers feature a clear coat finish. Because the veneers are sourced in large lots, overall color within a specific purchase order should have minimal color inconsistency. However, composite customers should know that colors may vary slightly from dye lot to dye lot. This inconsistency may be noticed when replacement pieces are ordered that may be from different dye lots, or when a new project phase is installed. Also note that composite veneers tend to fade and lighten over time, especially with sun exposure.

Flat-cut open-pore finish choices**Wood Group 1**

- 3JDX FC/OP Oak Composite
- 3JFX FC/OP Maple Composite
- 3JHX FC/OP Cherry Composite
- 3JJX FC/OP Walnut Composite

Applies to:

- Brody 488 Series desks
- Umami platform

Quarter-cut open-pore finish choices**Wood Group 1**

- 3F8X QC/OP European Walnut Composite
- 3GAX QC/OP Gold Teak Composite
- 3GFX QC/OP Rosewood Composite
- 3GGX QC/OP Zebano Composite
- 3HGX QC/OP Oak Composite
- 3HVX QC/OP Walnut Composite
- 3JEX QC/OP Maple Composite
- 3JGX QC/OP Cherry Composite
- 3ZNX QC/OP Night Cerused Oak Composite

Tip: Composite veneers are not available on tapered edge worksurfaces on Impact style numbers.

Tip: Be conscious if mixing the flat cut and the quarter cut in composites, as there may be large variation in color.

Applies to:

- Brody 488 Series desks
- Collaborative lounge table
- i2i tablet arm
- Snodgrass 474 Series chair frames
- Umami platform

Tip: Only open-pore finishes are available on Umami platform.

Natural Veneer

Natural veneer is available in the Select Surfaces offering. Natural veneer may have extended leadtimes. Place your order as you normally would for any other finish, calling out the appropriate finish code.

The following finishes are available through the natural veneer offering:

Flat-cut open-pore finish choices**Wood Group 1**

- 3342 FC/OP Black Walnut
- 35A2 FC/OP Blanch Maple
- 37A2 FC/OP Thunder Walnut

Wood Group 3

- 3082 FC/OP Washed Walnut

Flat-cut full-fill finish choices**Wood Group 1**

- 3734 FC/FF Black Walnut

Wood Group 3

- 3084 FC/FF Washed Walnut

Quarter-cut open-pore finish choices**Wood Group 1**

- 32A2 QC/OP Blanch Maple
- 33A2 QC/OP Thunder Walnut
- 3392 QC/OP Black Walnut

Quarter-cut full-fill finish choices**Wood Group 1**

- 3394 QC/FF Black Walnut

Rift-cut open-pore finish choices**Wood Group 1**

- 36A2 RC/OP Volcanic Oak

Premium Veneers

A selection of Premium veneers in this collection are available on most Steelcase brand products. The collection will be available as close to standard leadtimes as possible. However, because adequate supplies of veneer and solids must be secured, all orders will be scheduled individually. Leadtimes will vary based on Premium veneer and Premium solids availability at the time the order is placed. The collection is Graded-In as Wood Group 2 and Wood Group 3, and supported like standard veneers to make ordering easy. Please see the Steelcase surface materials section on village.steelcase.com for sample information and product line availability. All premium veneers are in clear-coat.

Applies to:

- Brody 488 Series desks
- i2i tablet arms
- Snodgrass
- Collaborative lounge table
- Umami platform

Quarter-cut open-pore finish choices**Wood Group 2**

- 3032 QC/OP Dark Thin Line Bamboo
- 3052 QC/OP Ribbon Sapele

Wood Group 3

- 3832 QC/OP Figured Anegre
- 3842 QC/OP Figured Makore

Tip: Full-fill finish is not available on premium veneers as a standard.

*To ensure an understanding of the color ranges and characteristic variations of natural veneer, a sign-off sheet is required prior to orders being accepted for this clear-coat finish. The sign-off sheet is available through Steelcase advertising stock. Please use form number 09-0000755 for 3032, form number 09-0000757 for 3052, form number 09-0000758 for 3832, and form number 09-0000759 for 3842.

*To ensure an understanding of the color ranges and characteristic variations of natural veneer, a sign-off sheet is required prior to orders being accepted for this clear-coat finish. The sign-off sheet is available through Steelcase advertising stock. Form number 05-0001370.

Applies to:

- Brody 488 Series desks
- Collaborative lounge table
- i2i tablet arm
- Snodgrass 474 Series chair frames
- Umami platform

Planked Veneer

Planked veneer is available in the Select Surfaces offering. Planked veneer may have extended leadtimes. Place your order as you normally would for any other finish, calling out the appropriate finish code.

The following finishes are available through the planked veneer offering:

Wood Group 1

3P41 OP Planked Cherry
3P51 OP Planked Maple
3P61 OP Planked Oak
3P71 OP Planked Walnut

Tip: Known for its uniqueness, planked veneer has intentional and natural variations that include, but are not limited to: character marks, grain pattern, color, and natural color aging.

Custom Surface

Customiz stain is a service that allows you to create your own stain colors and finishes on standard veneer. Customiz stain color is available on all product lines that offer wood veneer.

A \$500 stain-matching fee applies on CUSTOMIZ requests (Exception: The \$500 fee does not apply on matches to Coalesse standard finishes, for a low-gloss finish request on a standard color, or for composite stain matching to Steelcase wood seating. The \$500 fee covers the cost of formulating the Customiz color finish and applies regardless of whether or not an order for product is placed.

Tip: Due to natural variation of woodgrain color and texture, the match between composite veneers and composite stain color finishes will be a commercially acceptable match, rather than an exact match.

In addition, an approval form must be signed to indicate customer acceptance of Customiz match. A \$1,500 initiation fee will be charged prior to first order entry. This initiation fee activates the finish for unlimited use on any Steelcase product for an 18 month time period. After the 18 month time period has lapsed, the Customiz finish may be reactivated for another 18 months for a \$1,000 fee at any point within five years after the \$1,500 initiation fee was paid. If the finish is not reactivated within five years after the \$1,500 initiation fee was paid, the finish will be culled and the customer will need to pay the \$1,500 initiation fee again. All style number related Customiz charges products are no cost as of April 2014, with the exception of Umami platform. The matching and initiation fees are not discountable.

Customiz stain takes 10 days to formulate. Consult the *Surface Materials Reference Manual* for more information. Custom veneers are also available and must be quoted by Steelcase specials group. Customiz stain on custom veneers takes 2 to 4 weeks to formulate.

Requirements and information on ordering a Customiz stain color are found in the *Surface Materials Reference Manual*.

► See *c:scape Specification Guide* for the complete surface materials list for the i2i collaborative lounge table.

Screen

Applies to:

- Umami screen

Steelcase Surfaces

Price Group 1

Buzz2
Jacks
Link
Playground
New Black: Bruce
New Black: Henry

Price Group 2

Chainmail
Cogent: Connect
Cogent: Trails
Spyder
New Black: Harley
New Black: Jack
New Black: James

Price Group 3

Billiard Multi-Use by Designtex
Redeem
Retrieve

Elmosoft Leather

L110 Maritime Blue
L111 Midnight Blue
L112 Ebony
L113 Gunmetal
L114 Mica
L115 Dove Grey
L116 Plum Pleasure
L122 Truffle
L128 Red Birch
L132 Violet
L133 Espresso
L134 Ruby
L135 Scarlet
L136 Claret
L137 Cabernet
L138 Bourbon
L139 Cinder
L140 Garnet
L143 Pecan
L144 Chamois
L146 Russet
L147 Saddle
L151 White
L709 Sugar
L711 Parchment
L712 Buff
L716 Khaki
L717 Cameo
L721 Rock
L722 Desert
L723 Storm
L724 Mist
L725 Teal
L727 Egyptian Blue
L728 Bright Blue
L730 Hunter
L736 Lemon
L737 Sunshine
L738 Drama
L740 Dazzle
L743 Forest Green
L744 Turtle
L745 Grass
L746 Envy
L747 Cigar
L748 Light Chocolate
L749 Beaver
L750 Bluffstone
L751 Sienna
L752 Oxblood
L753 Dough
L754 Acorn
L755 Peanut Butter
L756 Quinoa
L757 Dark Sand
L758 Mustard
L759 Amber Orange
L760 Bengal
L761 Periwinkle
L762 Canvas
L763 Macadamia
L764 True Blue
L765 Storm Blue
L766 Powder Blue
L767 Blush
L768 Tropical
L769 Mauve
L770 Cadet
L771 Powder Mint
L772 Timberwolf
L773 Chalice
L774 Oil
L775 Coyote

Mesh

Steelcase Surfaces

Applies to:

- Jersey Series

Jersey Mesh

T084 Black
T085 Grey
T086 White
T087 Yellow
T088 Orange
T089 Red
T090 Green
T091 Blue
T094 Cardinal

Applies to

- Reply Series

Reply Air Mesh

AR01 Grey
AR02 Black
AR03 White
AR04 Red
AR05 Royal Blue
AR06 Apple Green
AR07 Orange
AR08 Bright Purple
AR09 Sable
AR13 Aubergine
AR14 Peacock
AR15 Jungle
AR16 Merlot
AR17 Honey
AR18 Lagoon
AR19 Saffron

3D Knit

Steelcase Surfaces

Applies to:

- i2i 416 Series
- Leap 462 Series
- Think 465 Series
- Amia 482 Series

5054 Canary
5059 Sailor
5064 Licorice
5065 Coconut
5066 Malt
5067 Root Beer
5089 Royal Blue
5090 Wasabi
5091 Maya Blue
5092 Graphite
5093 Nickel
5094 Tangerine
5095 Scarlet
5096 Turmeric/Honey
5097 Concord
5098 Blue Jay
5560 Aubergine
5561 Peacock
5562 Jungle
5563 Merlot
5564 Lagoon
5565 Saffron

Surface Materials, continued

Connect 3D**Steelcase Surfaces**

Applies to:

- cobi 434 Series
- 5014 Royal Blue
- 5015 Coconut
- 5016 Turmeric/Honey
- 5017 Tangerine
- 5018 Scarlet
- 5019 Concord
- 5020 Maya Blue
- 5021 Blue Jay
- 5023 Wasabi
- 5024 Nickel
- 5025 Graphite
- 5026 Licorice
- 5027 Malt
- 5028 Root Beer
- 5030 Sailor
- 5036 Canary
- 5532 Aubergine
- 5533 Peacock
- 5534 Jungle
- 5535 Merlot
- 5536 Lagoon
- 5537 Saffron

Seating Upholstery

Not every upholstery is available on every chair.

- ▶ Refer to the *Steelcase Upholstery Matrix* on page 450 before specifying.

Steelcase Surfaces**Price Group 1**

- Buzz2
- Era
- Jacks
- Link
- Playground

Price Group 2

- Chainmail
- Cogent: Connect
- Cogent: Trails
- Nitelights
- Seating Vinyl
- Spyder
- Stand In

Price Group 3

- Billiard Multi-Use by Designtex
- Gaja — Cradle to Cradle Certified™ Silver
- Imperma
- Redeem
- Retrieve
- Texel

Price Group 5

- Bo Peep
- Remix
- Silk

Price Group 6

- Brisa

Price Group 7

- Steelcut Trio

Leather Price Group

- Steelcase Leather

Elmosoft Leather Price Group

- Elmosoft Leather

Select Surfaces

For information on products within Select Surfaces, including accent paints, Signature plastics, and fabrics from Designtex, Gabriel, Kvadrat, and Pollack, please refer to the *Surface Materials Reference Manual* or visit www.steelcase.com/surface-materials under the Select Surfaces section.

Custom Surfaces**Price Group COM/ COL (Customer's Own Material/Leather)****Fabric Approval and Yardage**

To confirm whether a particular COM material has already been tested for use on a specific Steelcase product or to determine actual yardage requirements:

- Visit www.steelcase.com

For additional information regarding Customer's Own Material, contact Line 1 at 1.888.STEELCASE (1.888.783.3522) or send an email to lineone@steelcase.com.

Vertical Surface Fabric

Applies to:

- Brody screen fabric

Vertical upholstery is not available on all upholstered surfaces.

- ▶ See the Vertical Surface Fabric Matrix in *Surface Materials Reference Manual*.

Custom Surfaces**Price Group COM (Customer's Own Material)****Fabric Approval and Yardage**

To confirm whether a particular COM material has already been tested for use on a specific Steelcase product or to determine actual yardage requirements:

- Visit www.steelcase.com

Steel Color Availability Matrix, continued

Legend

- = Not available
- = Available
- = Available with exceptions
- ▶ See specification pages for details.

		Lux Coatings— Select Surfaces										Laminate									
		4B20	4B22	4B23	4B24	4B25	4B26	4B27	4B28	4B29	4B30	2406	2409	2410	2412	2422	2511	2535	2536	2538	2539
		Obsidian	Matte Brass	Burnished Bronze	Night Bronze	Matte Copper	Smoked Mica	Blue Steel	Silver Lilac	Cast Iron	Bright Gold	Clear Cherry	Clear Maple	Graphite Walnut	Natural Cherry	Medium Cherry	Winter on Maple	Virginia Walnut	Blackwood	Clear Walnut	Warm Oak
Amia 482 Series	Base and frame	•	•	•	•	•	•	•	•	•	•	•	•	•	•	•	•	•	•	•	•
	Outer seat and back	•	•	•	•	•	•	•	•	•	•	•	•	•	•	•	•	•	•	•	•
	Air back	•	•	•	•	•	•	•	•	•	•	•	•	•	•	•	•	•	•	•	•
	Arms	•	•	•	•	•	•	•	•	•	•	•	•	•	•	•	•	•	•	•	•
	Stool base and frame	•	•	•	•	•	•	•	•	•	•	•	•	•	•	•	•	•	•	•	•
	Stool foot ring	•	•	•	•	•	•	•	•	•	•	•	•	•	•	•	•	•	•	•	•
B-Free Tables	Top	•	•	•	•	•	•	•	•	•	•	■	■	■	■	■	■	■	■	■	■
	Base	■	■	■	■	■	■	■	■	■	■	•	•	•	•	•	•	•	•	•	•
Brody 488 WorkLounge	Foot and screen brackets	■	■	■	■	■	■	■	■	■	■	•	•	•	•	•	•	•	•	•	•
	Frame, power, and caddy	•	•	•	•	•	•	•	•	•	•	•	•	•	•	•	•	•	•	•	•
	Back of caddy	•	•	•	•	•	•	•	•	•	•	•	•	•	•	•	•	•	•	•	•
	Lower surround trim	•	•	•	•	•	•	•	•	•	•	•	•	•	•	•	•	•	•	•	•
	Seat shell	•	•	•	•	•	•	•	•	•	•	•	•	•	•	•	•	•	•	•	•
	Personal worksurface	•	•	•	•	•	•	•	•	•	•	•	•	•	•	•	•	•	•	•	•
	Personal worksurface arm	■	■	■	■	■	■	■	■	■	■	•	•	•	•	•	•	•	•	•	•
	Side surface	•	•	•	•	•	•	•	•	•	•	•	•	■	•	•	■	■	•	•	•
Brody 488 Desk	Foot and screen brackets	■	■	■	■	■	■	■	■	■	■	•	•	•	•	•	•	•	•	•	•
	Frame	•	•	•	•	•	•	•	•	•	•	•	•	•	•	•	•	•	•	•	•
	Lower surround trim	•	•	•	•	•	•	•	•	•	•	•	•	•	•	•	•	•	•	•	•
	Power	•	•	•	•	•	•	•	•	•	•	•	•	•	•	•	•	•	•	•	•
Cachet 487 Series	Swivel and 4-leg frame	•	•	•	•	•	•	•	•	•	•	•	•	•	•	•	•	•	•	•	•
	Stool frame	•	•	•	•	•	•	•	•	•	•	•	•	•	•	•	•	•	•	•	•
cobi 434 Series	Base and back frame	•	•	•	•	•	•	•	•	•	•	•	•	•	•	•	•	•	•	•	•
	Arm caps, top edge, and casters	•	•	•	•	•	•	•	•	•	•	•	•	•	•	•	•	•	•	•	•
	Outer back	•	•	•	•	•	•	•	•	•	•	•	•	•	•	•	•	•	•	•	•
	Foot ring	•	•	•	•	•	•	•	•	•	•	•	•	•	•	•	•	•	•	•	•
Criterion 453 Series	Base, arms, outer seat, and back	•	•	•	•	•	•	•	•	•	•	•	•	•	•	•	•	•	•	•	•
	Foot ring	•	•	•	•	•	•	•	•	•	•	•	•	•	•	•	•	•	•	•	•
Gesture 442 Series	Base	•	•	•	•	•	•	•	•	•	•	•	•	•	•	•	•	•	•	•	•
	Arms	•	•	•	•	•	•	•	•	•	•	•	•	•	•	•	•	•	•	•	•
	Seat perimeter, back shell, and headrest	•	•	•	•	•	•	•	•	•	•	•	•	•	•	•	•	•	•	•	•
	Back frame	•	•	•	•	•	•	•	•	•	•	•	•	•	•	•	•	•	•	•	•
i2i 416 Series	Outer back	•	•	•	•	•	•	•	•	•	•	•	•	•	•	•	•	•	•	•	•
	Base and cylinder	•	•	•	•	•	•	•	•	•	•	•	•	•	•	•	•	•	•	•	•
	Tablet arm	•	•	•	•	•	•	•	•	•	•	•	•	•	•	•	■	•	•	•	•
Jersey Series	Work chair	•	•	•	•	•	•	•	•	•	•	•	•	•	•	•	•	•	•	•	•
	Guest chair	•	•	•	•	•	•	•	•	•	•	•	•	•	•	•	•	•	•	•	•
Kart	Base, back supports, and arm support bar	•	•	•	•	•	•	•	•	•	•	•	•	•	•	•	•	•	•	•	•
	Back frame and seat shell	•	•	•	•	•	•	•	•	•	•	•	•	•	•	•	•	•	•	•	•
	Arm caps and casters	•	•	•	•	•	•	•	•	•	•	•	•	•	•	•	•	•	•	•	•
	Stool foot ring	•	•	•	•	•	•	•	•	•	•	•	•	•	•	•	•	•	•	•	•
Leap 462 Series	Base and ribbon frame	•	•	•	•	•	•	•	•	•	•	•	•	•	•	•	•	•	•	•	•
	Outer seat and back	•	•	•	•	•	•	•	•	•	•	•	•	•	•	•	•	•	•	•	•
	Arms	•	•	•	•	•	•	•	•	•	•	•	•	•	•	•	•	•	•	•	•
	Stool base and ribbon frame	•	•	•	•	•	•	•	•	•	•	•	•	•	•	•	•	•	•	•	•
	Stool foot ring	•	•	•	•	•	•	•	•	•	•	•	•	•	•	•	•	•	•	•	•

Steel Color Availability Matrix, continued

Legend

- = Not available
- = Available
- = Available with exceptions
- ▶ See specification pages for details.

		Plastic																									
		6009	6052	6053	6059	6205	6248	6249	6250	6256	6259	6295	6296	6302	6332	6333	6334	6335	6336	6337	6338	6421	6527	6654	6BD8	6BD9	6BE1
		Arctic White	Milk	Seagull	Sterling Dark Solid	Black	Midnight Brown	Platinum Solid	Coffee	Graphite	Midnight	Near Black	Sterling	Baltic	Citron	Picasso	Flash	Wasabi	Jazz	Element	Chili Red	Ash	Merle	Sand	Snow	Carbon Flat	Ore
Max-Stacker 477 Series	Frame and bookrack	•	•	•	•	•	•	•	•	•	•	•	•	•	•	•	•	•	•	•	•	•	•	•	•	•	•
	Seat and back	■	•	•	■	■	•	■	•	•	■	•	•	•	■	■	■	■	■	■	■	•	•	•	■	■	■
	Tablet arm	•	•	•	•	•	•	•	•	•	•	•	•	•	•	•	•	•	•	•	•	•	•	•	•	•	•
Move 490 Series	Frame	•	•	•	•	•	•	•	•	•	•	•	•	•	•	•	•	•	•	•	•	•	•	•	•	•	•
	Back shell and arms	■	•	•	■	■	•	■	•	•	■	•	•	•	■	■	■	■	■	■	■	•	•	•	■	■	■
Node 480 Series	Shell	■	•	•	■	■	•	■	•	•	■	•	•	•	■	■	■	■	■	■	■	•	•	•	■	■	■
	Personal worksurface	•	•	■	•	•	•	■	•	•	•	■	•	•	•	•	•	•	•	■	•	•	•	■	•	•	•
	Tripod base	•	•	•	•	•	•	■	•	•	•	■	•	•	•	•	•	•	•	■	•	•	•	•	•	•	•
	Stool base	•	•	•	•	■	•	■	•	•	•	•	•	•	•	•	•	•	•	■	•	•	•	•	•	•	•
Player 475 Series	Frame on chairs with smooth arms	•	•	•	•	■	•	■	■	•	•	•	•	•	•	•	•	•	•	•	•	•	•	•	•	•	•
	Smooth arms	•	•	•	•	■	•	■	■	•	•	•	•	•	•	•	•	•	•	•	•	•	•	•	•	•	•
	Frame on chairs with textured arms	•	•	•	•	■	•	■	•	•	•	•	•	•	•	•	•	•	•	•	•	•	•	•	•	•	•
	Textured arms	•	•	•	•	■	•	■	•	•	•	•	•	•	•	•	•	•	•	•	•	•	•	•	•	•	•
Protégé 433 Series	Tablet arm	•	•	•	•	•	•	•	•	•	•	•	•	•	•	•	•	•	•	•	•	•	•	•	•	•	•
	Base, arms, and sled base	•	•	•	•	■	•	■	■	•	•	•	•	•	•	•	•	•	•	•	•	•	•	•	•	•	•
	Arm caps and outer back shell	•	•	•	•	■	•	•	■	•	•	•	•	•	•	•	•	•	•	•	•	•	•	•	•	•	•
	Casters	•	•	•	•	■	•	•	•	•	•	•	•	•	•	•	•	•	•	•	•	•	•	•	•	•	•
QiVi 428 Series	Back frame, seat shell, and arm caps	■	•	•	•	■	•	■	•	•	•	•	•	•	•	•	•	•	•	•	•	•	•	•	•	•	•
	Base	■	•	•	•	■	•	■	•	•	•	•	•	•	•	•	•	•	•	•	•	•	•	•	•	•	•
	Frame	■	•	•	•	■	•	■	•	•	•	•	•	•	•	•	•	•	•	•	•	•	•	•	•	•	•
	Stool foot ring	•	•	•	•	■	•	■	•	•	•	•	•	•	•	•	•	•	•	•	•	•	•	•	•	•	•
Reply 466 Series	Stool base	•	•	•	•	■	•	•	•	•	•	•	•	•	•	•	•	•	•	•	•	•	•	•	•	•	•
	Base and arm support	•	•	•	•	■	•	■	•	•	•	•	•	•	•	•	•	•	•	•	•	•	•	•	•	•	•
	Frame, outer back, arm caps, arm tube, and casters	•	•	□	•	■	•	•	•	•	•	•	•	•	•	•	•	•	•	•	•	•	•	•	•	•	•
	Base and arm supports	•	•	•	•	•	•	•	•	•	•	•	•	•	•	•	•	•	•	•	•	•	•	•	•	•	•
Siento 499 Serie	Base and arm supports	•	•	•	•	•	•	•	•	•	•	•	•	•	•	•	•	•	•	•	•	•	•	•	•	•	•
Snodgrass 474 Series	Frame	•	•	•	•	■	•	■	•	•	•	•	•	•	•	•	•	•	•	•	•	•	•	•	•	•	•
Think 465 Series	Base	•	•	•	•	■	•	•	•	•	•	•	•	•	•	•	•	•	•	•	•	•	•	•	•	•	•
	Frame and arm supports	•	•	■	•	■	•	•	•	•	•	•	•	•	•	•	•	•	•	•	•	•	•	•	•	•	•
	Stool frame and arm supports	•	•	•	•	■	•	•	•	•	•	•	•	•	•	•	•	•	•	•	•	•	•	•	•	•	•
	Stool foot ring	•	•	•	•	■	•	•	•	•	•	•	•	•	•	•	•	•	•	•	•	•	•	•	•	•	•
Stool base	•	•	•	•	■	•	•	•	•	•	•	•	•	•	•	•	•	•	•	•	•	•	•	•	•	•	

FCS models for Amia, Leap, and Think meet fire code requirements only when specified with fully adjustable arms or armless.
 FCS models for Criterion are available with 6205 Black plastic only.
 FCS models for Gesture are available with black/black color scheme only.
 FCS models for Move are available with 6205 Black or 6249 Platinum Solid plastic only.
 FCS models for i2i are available with 6249 Platinum Solid or 6295 Near Black plastic only.
 FCS models for Node are available with 6205 Black, 6259 Midnight, 6335 Wasabi, or 6336 Jazz only.
 FCS models for Reply, Seagull available on mesh version only.

Signature Plastics— Select Surfaces	
6BC2 Purple	•
6BC5 Blue	•
6BC8 Gold	•
6BD1 Aubergine	•
6BD2 Peacock	•
6BD3 Jungle	•
6BD4 Merlot	•
6BD5 Honey	•
6BD6 Lagoon	•
6BD7 Saffron	•
Metal	
8046 Polished Aluminum	•
9201 Polished Chrome	■
Accessory Paint	
4140 Arctic White Gloss	•
Paint	
0835 Black	•
4146 Champagne Matte	•
4750 Champagne Metallic	•
4799 Platinum Metallic	■
4803 Near Black Metallic	•
7207 Black	•

Seating

Steel Color Availability Matrix, continued

Legend

- = Not available
- = Available
- = Available with exceptions
- ▶ See specification pages for details.

		Paint, cont.				Lux Coatings—Select Surfaces										Seating Coating			Laminate									
		7239	7241	7243	7250	4B20	4B22	4B23	4B24	4B25	4B26	4B27	4B28	4B29	4B30	7000	2406	2409	2410	2412	2422	2511	2538	2539				
		Midnight	Arctic White	Seagull	Sterling Dark	Obsidian	Matte Brass	Burnished Bronze	Night Bronze	Matte Copper	Smoked Mica	Blue Steel	Silver Lilac	Cast Iron	Bright Gold	Black	Clear Cherry	Clear Maple	Graphite Walnut	Natural Cherry	Medium Cherry	Winter on Maple	Clear Walnut	Warm Oak				
Max-Stacker 477 Series	Frame and bookrack	■	•	•	•	■	■	■	■	■	■	■	■	■	■	■	•	•	•	•	•	•	•	•				
	Seat and back	•	•	•	•	•	•	•	•	•	•	•	•	•	•	•	•	•	•	•	•	•	•	•				
	Tablet arm	•	•	•	•	•	•	•	•	•	•	•	•	•	•	•	■	■	■	■	■	■	■	■				
Move 490 Series	Frame	•	•	•	•	■	■	■	■	■	■	■	■	■	■	•	•	•	•	•	•	•	•	•				
	Back shell and arms	•	•	•	•	•	•	•	•	•	•	•	•	•	•	•	•	•	•	•	•	•	•	•				
Node 480 Series	Shell	•	•	•	•	•	•	•	•	•	•	•	•	•	•	•	•	•	•	•	•	•	•	•				
	Personal worksurface	•	•	•	•	•	•	•	•	•	•	•	•	•	•	•	•	•	•	•	•	•	•	•				
	Tripod base	•	•	•	•	•	•	•	•	•	•	•	•	•	•	•	•	•	•	•	•	•	•	•				
Player 475 Series	Stool base	•	•	•	•	•	•	•	•	•	•	•	•	•	•	•	•	•	•	•	•	•	•	•				
	Frame on chairs with smooth arms	•	•	•	•	•	•	•	•	•	•	•	•	•	•	•	•	•	•	•	•	•	•	•				
	Smooth arms	•	•	•	•	•	•	•	•	•	•	•	•	•	•	•	•	•	•	•	•	•	•	•				
	Frame on chairs with textured arms	•	•	•	•	•	•	•	•	•	•	•	•	•	•	•	•	•	•	•	•	•	•	•				
Protégé 433 Series	Textured arms	•	•	•	•	•	•	•	•	•	•	•	•	•	•	•	•	•	•	•	•	•	•	•				
	Tablet arm	•	•	•	•	•	•	•	•	•	•	•	•	•	•	•	•	•	•	•	•	•	•	•				
	Base, arms, and sled base	•	•	•	•	•	•	•	•	•	•	•	•	•	•	•	•	•	•	•	•	•	•	•				
	Arm caps and outer back shell	•	•	•	•	•	•	•	•	•	•	•	•	•	•	•	•	•	•	•	•	•	•	•				
QiVi 428 Series	Casters	•	•	•	•	•	•	•	•	•	•	•	•	•	•	•	•	•	•	•	•	•	•	•				
	Back frame, seat shell, and arm caps	•	•	•	•	□	□	□	□	□	□	□	□	□	□	•	•	•	•	•	•	•	•	•				
	Base	•	•	•	•	•	•	•	•	•	•	•	•	•	•	•	•	•	•	•	•	•	•	•				
	Frame	•	•	•	•	•	•	•	•	•	•	•	•	•	•	•	•	•	•	•	•	•	•	•				
	Stool foot ring	•	•	■	•	•	•	•	•	•	•	•	•	•	•	•	•	•	•	•	•	•	•	•				
Reply 466 Series	Stool base	•	■	•	•	•	•	•	•	•	•	•	•	•	•	•	•	•	•	•	•	•	•	•				
	Base and arm support	•	•	•	•	•	•	•	•	•	•	•	•	•	•	•	•	•	•	•	•	•	•	•				
Siento 499 Serie	Frame, outer back, arm caps, arm tube, and casters	•	•	•	•	•	•	•	•	•	•	•	•	•	•	•	•	•	•	•	•	•	•	•				
	Base and arm supports	•	•	•	•	•	•	•	•	•	•	•	•	•	•	•	•	•	•	•	•	•	•	•				
Snodgrass 474 Series	Frame	•	•	•	•	•	•	•	•	•	•	•	•	•	•	•	•	•	•	•	•	•	•	•				
Think 465 Series	Base	•	•	■	•	•	•	•	•	•	•	•	•	•	•	•	•	•	•	•	•	•	•	•				
	Frame and arm supports	•	•	■	•	•	•	•	•	•	•	•	•	•	•	•	•	•	•	•	•	•	•	•				
	Stool frame and arm supports	•	•	■	•	•	•	•	•	•	•	•	•	•	•	•	•	•	•	•	•	•	•	•				
	Stool foot ring	•	•	•	•	•	•	•	•	•	•	•	•	•	•	•	•	•	•	•	•	•	•	•				
	Stool base	•	•	■	•	•	•	•	•	•	•	•	•	•	•	•	•	•	•	•	•	•	•	•				

Wood Color Availability Matrix

Not every wood color is available on every seating component. This matrix gives an overview of which wood colors can be specified for each seating component.

Legend

- = Not available
- = Available
- = Available with exceptions
- ▶ See specification pages for details.

	B-Free Tables	B-Free Beam	Collaboration	Mingle	Node	Sawyer	Snodgrass
3062 Graphite Walnut	•	•	■	■	•	■	■
3402 Clear Cherry (Aged)	•	•	■	■	•	■	■
3412 Natural Cherry	•	•	■	■	•	■	■
3422 Medium Cherry	•	•	■	■	•	■	■
3522 Clear Maple**	•	•	■	■	•	■	■
3572 Amber on Maple	•	•	■	■	•	■	■
3592 Blonde on Maple	•	•	■	■	•	■	■
3602 Desert Oak	•	•	■	■	•	■	■
3612 Warm Oak	•	•	■	■	•	■	■
3692 Espresso Oak	•	•	■	■	•	■	■
3702 Clear Walnut	•	•	■	■	•	■	■
3712 Natural Walnut	•	•	■	■	•	■	■
3722 Dark Mahogany on Walnut	•	•	■	■	•	■	■
3752 Medium Walnut	•	•	■	■	•	■	■
3762 Dark Walnut	•	•	■	■	•	■	■
3772 Medium Mahogany on Walnut	•	•	■	■	•	■	■
3860 Espresso	■	■	•	•	•	•	•
3861 Natural	■	■	•	•	•	•	•
Flat Cut, Low Sheen*							
V1AC Natural Cherrywood	•	•	•	•	■	•	•
V1AM Clear Maplewood	•	•	•	•	■	•	•
V1CC Medium Amber Cherrywood	•	•	•	•	■	•	•
V1EW Dark Walnut	•	•	•	•	■	•	•

Tip: The wood used in the construction of chairs is either maple or European beech. Wood finishes applied to maple or beech will match the color of stains applied to oak, walnut, or cherry, but will not have the same natural grain. Composite color finishes will match the color of composites on veneered surfaces, but will not have the same grain pattern.

**See Coalesse Surface Materials Reference Guide for more information on this finish.*

***To ensure an understanding of the color ranges and characteristic variations of natural veneer, a sign-off is required prior to orders being accepted for this clear-coat finish. The sign-off sheet is available through Steelcase advertising stock. Form number 05-0001370*

Tip: Wood color 3522 is a clear coat. Therefore, the natural variations in wood (maple or European beech) will be visible.

Tip: Due to natural variations in wood, finish products may vary in color, texture and grain.

Not every wood color is available on every seating component. This matrix gives an overview of which wood colors can be specified for each seating component.

Legend

- = Not available
- = Available
- = Available with exceptions
- ▶ See specification guide for details.

	Collaboration	Mingle	Sawyer	Snodgrass
Composite Veneers				
Wood Group 1				
3F8X European Walnut Composite	•	•	•	•
3GAX Gold Teak Composite	•	•	•	•
3GFX Rosewood Composite	•	•	•	•
3GGX Zebrano Composite	•	•	•	•
3HGX Oak Composite	•	•	•	•
3HVX Walnut Composite	•	•	•	•
3JGX Cherry Composite	•	•	•	•
Natural Veneers				
Wood Group 1				
3342 Black Walnut	■	■	■	■
3392 Black Walnut	■	■	■	■
32A2 Blanch Maple	•	•	•	•
33A2 Thunder Walnut	•	•	•	•
35A2 Blanch Maple	■	■	■	■
36A2 Volcanic Oak	•	•	•	•
37A2 Thunder Walnut	■	■	■	■
Planked Veneers				
3P41 Planked Cherry	•	•	•	•
3P51 Planked Maple	•	•	•	•
3P61 Planked Maple	•	•	•	•
3P71 Planked Walnut	•	•	•	•

Tip: Composite color finishes will match the color of composites on veneered surfaces, but will not have the same grain pattern. Select composite color finishes will be available through the Customiz Stain process for no additional fee.

Tip: The wood used in the construction of chairs is either maple or European beech. Wood finishes applied to maple or beech will match the color of stains applied to oak, walnut, or cherry, but will not have the same natural grain.

Tip: Due to natural variations in wood, finish products may vary in color, texture and grain.

Wood Color Availability Matrix, continued

Not every wood color is available on every seating component. This matrix gives an overview of which wood colors can be specified for each seating component.

Legend

- = Not available
- = Available
- = Available with exceptions
- ▶ See specification pages for details.

	B-Free Tables	B-Free Beam	Collaboration	Mingle	Node	Sawyer	Snodgrass
Premium Veneers							
3032 Dark Thin Line Bamboo	•	•	•	•	•	•	•
3052 Ribbon Sapele	•	•	•	•	•	•	•
3832 Figured Anegre	•	•	•	•	•	•	•
3842 Figured Makore	•	•	•	•	•	•	•
Corian							
2801 Glacier White	•	•	•	•	•	•	•
2873 Linen	•	•	•	•	•	•	•
2875 Bisque	•	•	•	•	•	•	•
2972 Antarctica	•	•	•	•	•	•	•
2974 Canvas	•	•	•	•	•	•	•

Tip: The wood used in the construction of chairs is either maple or European beech. Wood finishes applied to maple or beech will match the color of stains applied to oak, walnut, or cherry, but will not have the same natural grain. Composite color finishes will match the color of composites on veneered surfaces, but will not have the same grain pattern.

**See Coalesse Surface Materials Reference Guide for more information on this finish.*

***To ensure an understanding of the color ranges and characteristic variations of natural veneer, a sign-off is required prior to orders being accepted for this clear-coat finish. The sign-off sheet is available through Steelcase advertising stock. Form number 05-0001370*

Tip: Wood color 3522 is a clear coat. Therefore, the natural variations in wood (maple or European beech) will be visible.

Tip: Due to natural variations in wood, finish products may vary in color, texture and grain.

Steel Seating Upholstery Matrix

Not every fabric is available on every chair. This matrix gives an overview of the upholstery fabrics that can be specified on each seating product line.

*Gaja — Cradle to Cradle Certified™ Silver

Legend

- = Not available
- = Available
- = Available with exceptions
- ▶ See specification pages for details.

	Price Group	Amia 482 Series - 3D Knit - Standard	Amia 482 Series - Standard	Amia 482 Series - 3D Knit - Sewn	Amia 482 Series - Sewn	Amia Air 482 - Sewn	Amia Air 482 Standard	B-Free Lounge	Basic Cushion	Brody 488 Series Worklounge - Seat	Brody 488 Series Worklounge - Lower Surround and Trim	Brody 488 Series Privacy Lounge - Seat	Brody 488 Series Privacy Lounge - Lower Surround and Trim	Brody 488 Series Privacy Lounge - Screen	Brody 488 Series Privacy Lounge with Extension - Seat	Brody 488 Series Privacy Lounge with Extension - Lower Surround and Trim	Brody 488 Series Privacy Lounge with Extension - Screen
3D Knit	NA	■	•	•	•	•	•	•	•	•	•	•	•	•	•	•	•
3D Microknit	NA	•	•	•	•	□	□	•	•	•	•	•	•	•	•	•	•
Billiard Multi-Use by DesignTex	3	■	■	■	■	■	■	■	■	■	■	■	■	■	■	■	■
Bo Peep	5	■	■	•	•	•	■	■	■	■	■	■	■	■	■	■	•
Brisa	6	■	■	■	■	■	■	■	•	■	■	■	■	■	■	■	•
Buzz2	1	■	■	■	■	■	■	■	■	■	■	■	■	■	■	■	■
Chainmail	2	■	■	•	•	•	■	■	■	■	■	■	■	■	■	■	•
Cogent: Connect	2	■	■	•	•	•	■	■	■	■	•	■	■	■	■	•	•
Cogent: Geode Vertical	2	■	■	•	•	•	■	■	•	■	■	■	■	■	■	■	•
Cogent: Trails	2	■	■	•	•	•	■	■	■	■	■	■	■	■	■	■	•
Connect 3D	NA	•	•	•	•	•	•	•	•	•	•	•	•	•	•	•	•
Elmosoft Leather	EL	•	•	■	■	■	•	■	•	■	•	■	•	■	■	•	•
Era	1	■	■	■	■	■	■	■	■	■	■	■	■	■	■	■	•
Gaja*	3	■	■	■	■	■	■	■	■	■	•	■	•	■	•	•	•
Imperma	3	■	■	•	•	•	■	■	■	■	•	■	•	■	•	•	•
Jacks	1	■	■	■	■	■	■	■	■	■	■	■	■	■	■	■	•
Jersey Black	NA	•	•	•	•	•	•	•	•	•	•	•	•	•	•	•	•
Steelcase Leather	L	•	•	■	■	■	•	■	•	■	•	■	•	■	•	•	•
Link	1	■	■	■	■	■	■	■	■	■	■	■	■	■	■	■	•

Amia 482 Series sewn version models with leather or vinyl require an "S" suffix which features an additional stitch detail across the lumbar region of the back cushion. Vinyl is not available on models with upholstered back.

Brody 488 Series vertical fabrics can be found in the *Vertical Surface Fabric Matrix* in the *Surface Materials Reference Manual*.

Legend

- = Not available
- = Available
- = Available with exceptions
- ▶ See specification pages for details.
- *Gaja — Cradle to Cradle Certified™ Silver

	Price Group	Brody 488 Series Footrest	Brody Desk	Cachet 487 Series - Standard	cobi 434 Series - Connect 3D - Standard	cobi 434 Series - Connect 3D - Sewn	Criterion 453 Series - Standard, Molded	Criterion 453 Series - Standard, Plus	Criterion 453 Series - Sewn	Criterion 453 Series - Sewn Back, Non-Sewn Seat	c:scape Screens	c:scape Cushion Tops	Divisio Side Screen	FrameOne	Gesture 442 Series - Non-Sewn	Gesture 442 Series - Sewn	Gesture 442 Series - 3D Knit - Non-Sewn	i2i 416 Series - 3D Knit - Sewn	Jersey 383 Series - Standard	Jersey 383 Series - Sewn
3D Knit	NA	•	•	•	•	•	•	•	•	•	•	•	•	•	•	■	■	■	•	•
3D Microknit	NA	•	•	•	•	•	•	•	•	•	•	•	•	•	•	•	•	•	•	•
Billiard Multi-Use by Designtex	3	■	■	■	•	■	■	■	•	•	■	■	■	■	•	■	■	■	■	•
Bo Peep	5	■	■	■	•	■	■	■	•	•	■	■	■	■	•	■	■	■	■	•
Brisa	6	■	■	•	•	■	■	■	■	•	■	■	■	■	•	■	■	■	■	•
Buzz2	1	■	■	■	•	■	•	■	•	•	■	■	■	■	•	■	■	■	■	•
Chainmail	2	■	■	■	•	■	■	■	•	•	■	■	■	■	•	■	■	■	■	•
Cogent: Connect	2	■	•	■	■	•	■	■	•	•	■	■	■	■	■	■	■	■	■	•
Cogent: Geode Vertical	2	■	■	■	•	■	■	■	•	•	■	■	■	■	•	■	■	■	■	•
Cogent: Trails	2	■	■	■	•	■	■	■	•	•	■	■	■	■	•	■	■	■	■	•
Connect 3D	NA	•	•	•	■	■	•	•	•	•	•	•	•	•	•	•	•	•	•	•
Elmosoft Leather	EL	■	•	■	•	■	•	■	•	•	■	■	■	■	•	■	■	■	■	•
Era	1	■	■	■	•	■	•	■	•	•	■	■	■	■	•	■	■	■	■	•
Gaja*	3	■	•	■	•	■	■	■	•	•	■	■	■	■	•	■	■	■	■	•
Imperma	3	■	•	■	•	■	■	■	•	•	■	■	■	■	•	■	■	■	■	•
Jacks	1	■	■	■	•	■	■	■	•	•	■	■	■	■	•	■	■	■	■	•
Jersey Black	NA	•	•	•	•	•	•	•	•	•	•	•	•	•	•	•	•	•	■	■
Steelcase Leather	L	■	•	■	•	■	•	■	•	•	■	■	■	■	•	■	■	■	■	•
Link	1	■	■	■	•	■	■	■	•	•	■	■	■	■	•	■	■	■	■	•

Steel Seating Upholstery Matrix, continued

Legend

- = Not available
- = Available
- = Available with exceptions
- ▶ See specification guide for details.

Leap 462 Series sewn version models with leather or vinyl require an "S" suffix which features an additional stitch detail across the lumbar region of the back cushion.

3D Knit upholstery is available only on models with 3D Knit Back. *Gaja — Cradle to Cradle Certified™ Silver

	Price Group	Kart	Leap 462 Series - 3D Knit - Standard	Leap 462 Series - Standard	Leap Plus 462 Series - 3D Knit - Standard	Leap Plus 462 Series - Standard	Leap 462 Series - 3D Knit - Sewn	Leap 462 Series - Sewn	Leap Plus 462 Series - 3D Knit - Sewn	Leap Plus 462 Series - Sewn	Leap 464 WorkLounge and Ottoman Series - Standard	Max-Stacker III 477 Series	media:scape kiosk	media:scape Lounge	Mobile Ped Cushion Tops - Avenir	Move 490 Series - Standard	Node 480 Series	Nooi	Player 475 Series - Standard	
3D Knit	NA	•	■	•	•	•	■	•	■	■	•	•	•	•	•	•	•	•	•	□
3D Microknit	NA	•	•	•	•	•	•	•	•	•	•	•	•	•	•	•	•	•	•	•
Billiard Multi-Use by DesignTex	3	■	■	■	■	■	•	•	•	•	•	•	•	■	■	■	■	■	■	■
Bo Peep	5	■	■	■	■	■	•	•	•	•	■	•	•	■	■	■	■	■	■	■
Brisa	6	■	■	■	•	•	•	■	■	■	•	•	•	■	■	■	■	■	■	■
Buzz2	1	■	■	■	■	■	•	•	•	•	•	•	•	■	■	■	■	■	■	■
Chainmail	2	■	■	■	■	■	•	•	•	•	•	•	•	■	■	■	■	■	■	■
Cogent: Connect	2	■	■	■	■	■	•	•	•	•	•	•	•	■	■	■	■	■	■	■
Cogent: Trails	2	■	■	■	■	■	•	•	•	•	•	•	•	■	■	■	■	■	■	■
Connect 3D	NA	•	•	•	•	•	•	•	•	•	•	•	•	•	•	•	•	•	•	•
Elmosoft Leather	EL	■	■	•	•	•	•	■	■	■	•	•	•	■	■	■	■	■	■	•
Era	1	■	■	■	■	■	•	•	•	•	•	•	•	■	■	■	■	■	■	■
Gaja*	3	■	■	■	■	■	•	•	•	•	•	•	•	■	■	■	■	■	■	■
Imperma	3	■	■	■	■	■	•	•	•	•	•	•	•	■	■	■	■	■	■	■
Jacks	1	■	■	■	■	■	•	•	•	•	•	•	•	■	■	■	■	■	■	■
Jersey Black	NA	•	•	•	•	•	•	•	•	•	•	•	•	•	•	•	•	•	•	•
Steelcase Leather	L	■	■	•	•	•	•	■	■	■	•	•	•	■	■	■	■	■	■	•
Link	1	■	■	■	■	■	•	•	•	•	•	•	•	■	■	■	■	■	■	■

Legend

- = Not available
- = Available
- = Available with exceptions
- ▶ See specification pages for details.
- *Gaja — Cradle to Cradle Certified™ Silver

	Price Group	Protégé 433 Series - Standard	Protégé 433 Series - Sewn	QiVi 428 Series - QiVi Net - Standard	QiVi 428 Series - QiVi Net - Sewn	Reply 466 Series Work Chair; Uph Seat-Mesh Back	Reply 466 Series Multi-Use Side Chair; Uph Seat-Mesh Back	Reply 466 Series Work chair; Uph Seat-Uph Back	Reply 466 Series Multi-Use Side Chair; Uph Seat-Uph Back	Reply 466 Series Work Chair - Sewn Seat-Mesh Back	Reply 466 Series Multi-Use Side Chair; Sewn Seat-Mesh Back	Reply 466 Series Work Chair; Sewn Seat-Sewn Back	Reply 466 Series Multi-Use Side Chair; Sewn Seat-Sewn Back	Siento 499 Series - Sewn	SILQ 418 Series - Standard	SILQ 418 Series - Sewn
3D Knit	NA	•	•	•	•	•	•	•	•	•	•	•	•	•	•	•
3D Microknit	NA	•	•	•	•	•	•	•	•	•	•	•	•	•	•	•
Billiard Multi-Use by Designtex	3	■	•	■	■	■	■	■	■	•	•	•	•	■	•	■
Bo Peep	5	■	■	■	■	■	■	■	■	•	•	•	•	■	■	•
Brisa	6	•	•	■	■	■	•	•	•	•	■	■	■	■	■	■
Buzz2	1	■	•	■	■	■	■	■	■	•	•	•	•	■	■	•
Chainmail	2	■	•	■	•	■	■	■	■	•	•	•	•	■	■	•
Cogent: Connect	2	■	•	■	■	■	■	■	■	•	•	•	•	■	■	•
Cogent: Geode Vertical	2	•	•	■	•	■	•	■	•	•	•	•	•	■	•	•
Cogent: Trails	2	•	•	■	•	■	•	•	•	•	•	•	•	■	•	•
Connect 3D	NA	•	•	•	•	•	•	•	•	•	•	•	•	•	•	•
Elmosoft Leather	EL	•	•	■	■	■	•	•	•	■	■	■	■	■	•	■
Era	1	■	•	■	■	■	■	■	■	•	•	•	•	■	•	•
Gaja*	3	■	•	■	■	■	■	■	■	•	•	•	•	■	■	•
Imperma	3	■	•	■	•	■	•	•	•	•	•	•	•	■	•	■
Jacks	1	■	•	■	•	■	■	■	■	•	•	•	•	■	•	•
Jersey Black	NA	•	•	•	•	•	•	•	•	•	•	•	•	•	•	•
Steelcase Leather	L	•	•	■	■	■	•	•	•	■	■	■	■	■	•	■
Link	1	■	•	■	•	■	■	■	■	•	•	•	•	■	■	•

Tip: SILQ 418 Series will only take warped vertical fabrics. This includes all standard Steelcase fabrics, Select Surfaces, and COMs.

Steel Seating Upholstery Matrix, continued

Legend

- = Not available
- = Available
- = Available with exceptions
- ▶ See specification guide for details.

Think 465 Series sewn version is available in leather and vinyl only on models with 3D Knit Back.

*Gaja — Cradle to Cradle Certified™ Silver

	Price Group	Snodgrass 474 Series - Standard	Steelcase Series 1	Think 465 Series - 3D Knit Back, Sewn Seat	Think 465 Series - Uph Back, Sewn Seat	Think 465 Series - Sewn Back, Sewn Seat	Umami	Universal Ped Cushion Tops - Standard, RPM and RPX	Universal Lateral Cushion Tops - RPDC, 2 Seam	Universal Lateral Cushion Tops - RPDC, 4 Seam	Universal Privacy Modesty Screen
3D Knit	NA	•	•	•	■	•	•	•	•	•	•
3D Microknit	NA	•	■	•	•	•	•	•	•	•	•
Billiard Multi-Use by DesignTex	3	■	■	■	■	•	•	•	•	■	•
Bo Peep	5	■	■	■	■	•	■	■	■	•	•
Brisa	6	■	■	■	•	•	•	•	•	■	•
Buzz2	1	■	■	■	■	•	■	■	•	■	•
Chainmail	2	■	■	■	■	•	•	■	■	•	•
Cogent: Connect	2	■	■	■	■	•	■	■	•	■	■
Cogent: Geode Vertical	2	■	■	■	■	•	•	■	■	•	•
Cogent: Trails	2	■	■	■	■	•	•	■	■	•	•
Connect 3D	NA	•	•	•	•	•	•	•	•	•	•
Elmosoft Leather	EL	■	■	■	•	•	•	•	•	■	•
Era	1	■	■	■	■	•	•	■	•	■	•
Gaja*	3	■	•	■	■	•	■	•	•	■	•
Imperma	3	■	■	■	■	•	•	■	■	•	•
Jacks	1	■	■	■	■	•	■	■	■	•	•
Jersey Black	NA	•	•	•	•	•	•	•	•	•	•
Steelcase Leather	L	■	■	■	•	•	•	•	•	■	•
Link	1	■	■	■	■	•	•	■	■	•	•

Legend

- = Not available
- = Available
- = Available with exceptions
- ▶ See specification pages for details.

	Price Group	Amia 482 Series - 3D Knit - Standard	Amia 482 Series - Standard	Amia 482 Series - 3D Knit - Sewn	Amia 482 Series - Sewn	Amia Air 482 - Sewn	Amia Air 482 Standard	B-Free Lounge	Basic Cushion	Brody 488 Series Worklounge - Seat	Brody 488 Series Worklounge - Lower Surround & Trim	Brody 488 Series Privacy Lounge - Seat	Brody 488 Series Privacy Lounge - Lower Surround & Trim	Brody 488 Series Privacy Lounge - Screen	Brody 488 Series Privacy Lounge with Extension - Seat	Brody 488 Series Privacy Lounge with Extension - Lower Surround & Trim	Brody 488 Series Privacy Lounge with Extension - Screen
New Black: Bruce	1	■	■	■	■	■	■	■	■	■	■	■	■	■	■	■	■
New Black: Harley	2	■	■	■	■	■	■	■	■	■	■	■	■	■	■	■	■
New Black: Henry	1	■	■	■	■	■	■	■	■	■	■	■	■	■	■	■	■
New Black: Jack	2	■	■	■	■	■	■	■	■	■	■	■	■	■	■	■	■
New Black: James	2	■	■	■	■	■	■	■	■	■	■	■	■	■	■	■	■
Nitelights	2	■	■	•	•	•	■	■	■	■	■	■	■	■	■	■	•
Playground	1	■	■	•	•	•	■	■	■	■	■	■	■	■	■	■	•
Redeem	3	■	■	■	■	■	■	■	■	■	•	■	•	•	■	•	•
Remix	5	■	■	■	■	■	■	■	■	■	■	■	■	■	■	■	•
Reply Air Mesh	NA	•	•	•	•	•	•	•	•	•	•	•	•	•	•	•	•
Retrieve	3	■	■	■	■	■	■	■	■	■	•	■	•	•	■	•	•
Seating Vinyl	2	•	•	■	□	□	•	■	•	■	■	■	■	■	■	•	•
Silk	5	■	■	■	■	■	■	■	■	■	■	■	■	■	■	■	•
Spyder	2	■	■	•	•	•	■	■	■	■	•	■	•	•	■	•	•
Stand In	2	•	•	■	■	■	•	■	•	■	•	■	•	•	■	•	•
Steelcut Trio	7	■	■	■	■	■	■	■	•	■	■	■	■	■	■	■	•
Texel	3	■	■	•	•	•	■	■	■	■	•	■	•	■	■	•	•

Seating

Steel Seating Upholstery Matrix, continued

Legend

- = Not available
- = Available
- = Available with exceptions
- ▶ See specification guide for details.

	Price Group	Brody 488 Series Footrest	Brody Desk	Cachet 487 Series - Standard	cobi 434 Series - Connect 3D - Standard	cobi 434 Series - Connect 3D - Sewn	Criterion 453 Series - Standard, Molded	Criterion 453 Series - Standard, Plus	Criterion 453 Series - Sewn	Criterion 453 Series - Sewn Back, Non-Sewn Seat	c:scape Screens	c:scape Cushion Tops	Divisio Side Screen	FrameOne	Gesture 442 Series - Non-Sewn	Gesture 442 Series - Sewn	Gesture 442 Series - 3D Knit - Non-Sewn	i2i 416 Series - 3D Knit - Sewn	Jersey 383 Series - Standard	Jersey 383 Series - Sewn
New Black: Bruce	1	■	■	•	•	■	■	■	•	•	•	•	•	•	■	■	■	■	■	•
New Black: Harley	2	■	■	•	•	■	■	■	•	•	•	■	•	•	■	■	■	■	■	•
New Black: Henry	1	■	■	•	•	■	■	■	•	•	•	■	•	•	■	■	■	■	■	•
New Black: Jack	2	■	■	•	•	■	■	■	•	•	•	■	•	•	■	■	■	■	■	•
New Black: James	2	■	■	•	•	■	■	■	•	•	■	■	•	•	■	■	■	■	■	•
Nitelights	2	■	•	■	•	■	■	■	•	•	•	■	•	•	■	■	■	■	■	•
Playground	1	■	■	■	•	■	■	■	•	•	•	■	•	•	■	■	■	■	■	•
Redeem	3	■	•	•	•	■	■	■	•	•	•	■	•	•	■	■	■	■	■	•
Remix	5	■	■	■	•	■	■	■	•	•	•	■	•	•	■	■	■	■	■	•
Reply Air Mesh	NA	•	•	■	•	•	•	•	•	•	•	■	•	•	•	•	•	•	■	•
Retrieve	3	■	•	•	•	■	■	■	•	•	•	■	•	•	■	■	■	■	■	•
Seating Vinyl	2	■	•	■	•	■	•	■	•	•	•	■	•	•	■	■	■	■	■	•
Silk	5	■	■	•	•	■	■	■	•	•	•	■	•	•	■	■	■	■	■	•
Spyder	2	■	•	■	•	■	■	■	•	•	•	■	•	•	■	■	■	■	■	•
Stand In	2	■	•	■	•	■	•	■	•	•	•	■	•	•	■	■	■	■	■	•
Steelcut Trio	7	■	■	■	•	■	•	■	•	•	•	■	•	•	■	■	■	■	■	•
Texel	3	■	•	■	•	■	■	■	•	•	•	■	•	•	■	■	■	■	■	•

Legend

- = Not available
- = Available
- = Available with exceptions
- ▶ See specification pages for details.

Leap 462 Series sewn version models with leather or vinyl require an "S" suffix which features an additional stitch detail across the lumbar region of the back cushion.

	Price Group	Kart	Leap 462 Series - 3D Knit - Standard	Leap 462 Series - Standard	Leap Plus 462 Series - 3D Knit - Standard	Leap Plus 462 Series - Standard	Leap 462 Series - 3D Knit - Sewn	Leap 462 Series - Sewn	Leap Plus 462 Series - 3D Knit - Sewn	Leap Plus 462 Series - Sewn	Leap 464 WorkLouge and Ottoman Series - Standard	Max-Stacker III 477 Series	media:scape kiosk	media:scape Lounge	Mobile Ped Cushion Tops - Avenir	Move 490 Series - Standard	Node 480 Series	Nooi	Player 475 Series - Standard	
New Black: Bruce	1	■	■	■	■	■	•	•	•	•	•	■	•	■	■	■	■	■	■	■
New Black: Harley	2	■	■	■	■	■	•	•	•	•	•	■	•	■	■	■	■	■	■	■
New Black: Henry	1	■	■	■	■	■	•	•	•	•	•	■	•	■	■	■	■	■	■	■
New Black: Jack	2	■	■	■	■	■	•	•	•	•	•	■	•	■	■	■	■	■	■	■
New Black: James	2	■	■	■	■	■	•	•	•	•	•	■	•	■	■	■	■	■	■	■
Nitelights	2	■	■	■	■	■	•	•	•	•	•	•	•	•	■	■	■	■	■	■
Playground	1	■	■	■	■	■	•	•	•	•	•	•	•	■	■	■	■	■	■	■
Redeem	3	■	■	■	■	■	•	•	•	•	•	•	•	■	■	■	■	■	■	■
Remix	5	■	■	■	■	■	•	•	•	•	•	•	•	■	■	■	■	■	■	■
Reply Air Mesh	NA	•	•	•	•	•	•	•	•	•	•	•	•	•	■	■	■	■	■	■
Retrieve	3	■	■	■	■	■	•	•	•	•	•	•	•	■	■	■	■	■	■	■
Seating Vinyl	2	■	■	•	•	•	•	■	■	■	•	•	•	■	■	■	■	■	■	■
Silk	5	■	■	■	■	■	•	•	•	•	•	•	•	■	■	■	■	•	■	■
Spyder	2	■	■	■	■	■	•	•	•	•	•	•	•	■	■	■	■	■	■	■
Stand In	2	■	■	•	•	•	•	■	■	■	•	•	•	■	■	■	■	•	■	■
Steelcut Trio	7	■	■	■	■	■	•	•	•	•	•	•	•	■	■	■	■	■	■	■
Texel	3	■	■	■	■	■	•	•	•	•	•	•	•	■	■	■	■	■	■	■

Steel Seating Upholstery Matrix, continued

Legend

- = Not available
- = Available
- = Available with exceptions
- ▶ See specification guide for details.

	Price Group	Protégé 433 Series - Standard	Protégé 433 Series - Sewn	QiVi 428 Series - QiVi Net - Standard	QiVi 428 Series - QiVi Net - Sewn	Reply 466 Series Work Chair; Uph Seat-Mesh Back	Reply 466 Series Multi-Use Side Chair; Uph Seat-Mesh Back	Reply 466 Series Work chair; Uph Seat-Uph Back	Reply 466 Series Multi-Use Side Chair; Uph Seat-Uph Back	Reply 466 Series Work Chair - Sewn Seat-Mesh Back	Reply 466 Series Multi-Use Side Chair; Sewn Seat-Mesh Back	Reply 466 Series Work Chair; Sewn Seat-Sewn Back	Reply 466 Series Multi-Use Side Chair; Sewn Seat-Sewn Back	Siento 499 Series - Sewn	SILQ 418 Series - Standard	SILQ 418 Series - Sewn
New Black: Bruce	1	■	•	■	•	■	■	■	■	•	•	•	•	■	•	■
New Black: Harley	2	■	•	■	•	■	■	■	■	•	•	•	•	■	■	•
New Black: Henry	1	■	•	■	•	■	■	■	■	•	•	•	•	■	■	•
New Black: Jack	2	■	•	■	•	■	■	■	■	•	•	•	•	■	■	•
New Black: James	2	■	•	■	•	■	■	■	■	•	•	•	•	■	■	•
Nitelights	2	■	•	■	•	■	■	■	■	•	•	•	•	■	■	•
Playground	1	■	•	■	•	■	■	■	■	•	•	•	•	■	■	•
Redeem	3	■	•	■	•	■	■	■	■	•	•	•	•	■	■	•
Remix	5	■	•	■	•	■	■	■	■	•	•	•	•	■	■	•
Reply Air Mesh	NA	•	•	■	•	■	■	■	■	■	■	■	■	•	•	•
Retrieve	3	■	•	■	•	■	■	■	■	•	•	•	•	■	■	•
Seating Vinyl	2	•	•	■	■	■	•	•	•	■	■	■	■	■	•	■
Silk	5	■	•	■	•	■	■	■	■	•	•	•	•	■	■	•
Spyder	2	■	•	■	•	■	■	■	■	•	•	•	•	■	■	•
Stand In	2	•	•	■	■	■	•	•	•	■	■	■	■	■	•	■
Steelcut Trio	7	■	•	■	■	■	■	■	■	•	•	•	•	■	■	•
Texel	3	■	•	■	•	■	■	■	■	•	•	•	•	■	■	•

Tip: SILQ 418 Series will only take warped vertical fabrics. This includes all standard Steelcase fabrics, Select Surfaces, and COMs.

Legend

- = Not available
- = Available
- = Available with exceptions
- ▶ See specification pages for details.

Think 465 Series sewn version is available in leather and vinyl only on models with 3D Knit Back.

	Price Group	Snodgrass 474 Series - Standard	Steelcase Series 1	Think 465 Series - 3D Knit Back, Sewn Seat	Think 465 Series - Uph Back, Sewn Seat	Think 465 Series - Sewn Back, Sewn Seat	Umami	Universal Ped Cushion Tops - Standard, RPM and RPX	Universal Lateral Cushion Tops - RPDC, 2 Seam	Universal Lateral Cushion Tops - RPDC, 4 Seam	Universal Privacy Modesty Screen
New Black: Bruce	1	■	■	■	■	■	•	■	•	■	•
New Black: Harley	2	■	■	■	■	■	•	■	•	■	•
New Black: Henry	1	■	■	■	■	■	■	■	•	■	•
New Black: Jack	2	■	■	■	■	■	■	■	•	■	•
New Black: James	2	■	■	■	■	■	■	■	•	■	•
Nitelights	2	■	■	■	■	■	■	■	■	•	•
Playground	1	■	■	■	■	■	■	■	■	•	•
Redeem	3	■	■	■	■	■	■	■	■	•	•
Remix	5	■	■	■	■	■	■	■	■	•	•
Reply Air Mesh	NA	■	•	•	•	•	•	■	■	•	•
Retrieve	3	■	■	■	■	■	■	■	■	•	•
Seating Vinyl	2	■	■	■	•	•	■	•	•	■	•
Silk	5	■	■	■	■	■	■	■	■	■	•
Spyder	2	■	■	■	■	■	■	■	■	•	•
Stand In	2	■	■	■	•	•	•	•	•	■	•
Steelcut Trio	7	■	■	■	■	■	■	■	■	•	•
Texel	3	■	■	■	■	■	■	■	■	•	•

Wood Seating Upholstery Matrix

Legend

- = Not available
- = Available
- = Available with exceptions
- ▶ See specification pages for details.
- *Gaja — Cradle to Cradle Certified™ Silver

Not every fabric is available on every chair. This matrix gives an overview of the upholstery fabrics that can be specified on each seating product line.

	Price Group	Collaboration	Mingle	Sawyer	Snodgrass
Billiard Multi-Use by Designtex	3	■	■	■	■
Bo Peep	5	■	■	■	■
Brisa	6	■	■	■	■
Buzz2	1	■	■	■	■
Chainmail	2	■	■	■	■
Cogent: Connect	2	■	■	■	■
Cogent: Geode Vertical	2	■	■	■	■
Cogent: Trails	2	■	■	■	■
Elmosoft Leather	EL	•	•	•	■
Era	1	■	■	■	■
Gaja*	3	■	■	■	■
Imperma	3	■	■	■	■
Jacks	1	■	■	■	■
Steelcase Leather	L	■	■	■	■
Link	1	■	■	■	■

Tip: Certain fabrics and leathers appear loose with comfort wrinkles when upholstered.

Legend

- = Not available
- = Available
- = Available with exceptions
- ▶ See specification pages for details.
- *Gaja — Cradle to Cradle Certified™ Silver

Not every fabric is available on every chair. This matrix gives an overview of the upholstery fabrics that can be specified on each seating product line.

	Price Group	Collaboration	Mingle	Sawyer	Snodgrass
New Black: Bruce	1	■	■	■	■
New Black: Harley	2	■	■	■	■
New Black: Henry	1	■	■	■	■
New Black: Jack	2	■	■	■	■
New Black: James	2	■	■	■	■
Nitelights	2	■	■	■	■
Playground	1	■	■	■	■
Redeem	3	■	■	■	■
Remix	5	■	■	■	■
Reply Air Mesh	NA	■	•	•	•
Retrieve	3	■	■	■	■
Seating Vinyl	2	•	•	■	■
Silk	5	■	■	■	■
Spyder	2	■	■	■	■
Stand In	2	•	•	■	■
Steelcut Trio	7	■	■	■	■
Texel	3	■	■	■	■

Fire Code Steel Seating Upholstery Matrix

Fire Code Seating (FCS) indicates that a product is constructed to meet the strict fire code requirements of high public occupancy areas. For further detail regarding exceptions, see the specific chapter within the *Seating Specification Guide* or the *Surface Materials Reference Manual*.

Legend

- = Not available
- = Available
- = Available with exceptions
- ◻ = Untested
- ▶ See specification pages for details.

	Amia 482 Series - FCS, 3D Knit, Standard	Amia 482 Series - FCS, Standard	Amia 482 Series - FCS, 3D Knit, Sewn	Amia 482 Series - FCS, Sewn	cobi 434 Series - FCS, Connect 3D, Standard	cobi 434 Series - FCS, Connect 3D, Sewn	Gesture 442 Series - FCS, Non-Sewn	Gesture 442 Series - FCS, Sewn	Gesture 442 Series - FCS, 3D Knit, Non-Sewn	Jersey 383 Series - FCS, Standard	Jersey 383 Series - FCS, Sewn	Leap 462 Series - FCS, 3D Knit, Standard	Leap 462 Series - FCS, Standard
Bo Peep	■	■	•	•	•	■	•	•	◻	•	•	■	■
Brisa	□	■	•	•	•	■	•	•	◻	•	•	■	◻
Buzz2	■	■	•	•	•	■	•	•	◻	•	•	■	■
Chainmail	■	◻	•	•	•	■	•	•	◻	•	•	■	■
Cogent: Connect	■	■	•	•	■	•	•	•	◻	•	•	■	■
Cogent: Geode Vertical	■	■	•	•	•	■	•	•	◻	•	•	■	■
Cogent: Trails	■	■	•	•	•	■	•	•	◻	•	•	■	■
Connect 3D	•	•	•	•	•	•	•	•	•	•	•	•	•
Elmosoft Leather	•	•	•	■	•	■	•	•	◻	•	•	■	•
Gaja - Cradle to Cradle Certified™	■	■	•	•	•	■	•	•	◻	•	•	■	■
Imperma	□	•	•	•	•	■	•	•	◻	•	•	■	◻
Jacks	■	■	•	•	•	■	•	•	◻	•	•	■	■
Steelcase Leather	•	•	•	■	•	■	•	•	◻	•	•	■	•
Link	■	■	•	•	•	■	•	•	◻	•	•	■	■

Amia 482 models meet fire code requirements only when specified with fully adjustable arms or armless.
cobi 434 Series fire code models are available in the following Connect 3D colors only: 5021 Blue Jay, 5023 Wasabi, 5025 Graphite, 5026 Licorice, 5027 Malt, and 5028 Root Beer.
Leap 462 models meet fire code requirements only when specified with fully adjustable arms or armless.

Fire Code Seating (FCS) indicates that a product is constructed to meet the strict fire code requirements of high public occupancy areas. For further detail regarding exceptions, see the specific chapter within the *Seating Specification Guide* or the *Surface Materials Reference Manual*.

Legend

- = Not available
- = Available
- = Available with exceptions
- ▣ = Untested
- ▶ See specification pages for details.

	Leap Plus 462 Series - FCS, 3D Knit, Standard	Leap Plus 462 Series - FCS, Standard	Leap 462 Series - FCS, 3D Knit, Sewn	Leap 462 Series - FCS, Sewn	Leap Plus 462 Series - 3D Knit - Sewn	Leap Plus 462 Series - Sewn	Leap 464 WorkLounge and Ottoman Series - FCS	Move 490 Series - FCS	QIVI 428 Series - FCS, QIVI Net, Standard	QIVI 428 Series - FCS, QIVI Net, Sewn	Think 465 Series - 3D Knit Back, Sewn Seat	Think 465 Series - Uph Back, Sewn Seat	Think 465 Series - Sewn Back, Sewn Seat
Bo Peep	■	■	•	•	•	•	▣	■	■	■	■	■	•
Brisa	•	•	•	■	▣	▣	•	■	■	■	■	■	•
Buzz2	■	■	•	•	•	•	•	■	■	■	■	■	•
Chainmail	■	■	•	•	•	•	•	■	■	•	■	■	•
Cogent: Connect	■	■	•	•	•	•	•	■	■	■	■	■	•
Cogent: Geode Vertical	■	■	•	•	•	•	•	■	■	•	■	■	•
Cogent: Trails	■	■	•	•	•	•	•	■	■	•	■	■	•
Connect 3D	•	•	•	•	•	•	•	•	•	•	•	•	•
Elmosoft Leather	•	•	•	■	■	■	•	■	■	■	■	■	■
Gaja - Cradle to Cradle Certified™	■	■	•	•	•	•	•	■	■	■	■	■	•
Imperma	▣	▣	•	•	•	•	•	■	■	•	■	■	•
Jacks	■	■	•	•	•	•	•	■	■	•	■	■	•
Steelcase Leather	•	•	•	■	■	■	•	■	■	■	■	■	■
Link	■	■	•	•	•	•	•	■	■	•	■	■	•

Move models meet fire code requirements only when specified with 6205 Black or 6249 Platinum Solid plastic.
Leap 462 models meet fire code requirements only when specified with fully adjustable arms or armless.
Think 465 models meet fire code requirements only when specified with fully adjustable arms or armless.
 Models specified with vinyl meet firecode requirements only when specified armless.

Fire Code Steel Seating Upholstery Matrix, continued

Fire Code Seating (FCS) indicates that a product is constructed to meet the strict fire code requirements of high public occupancy areas. For further detail regarding exceptions, see the specific chapter within the *Seating Specification Guide* or the *Surface Materials Reference Manual*.

Legend

- = Not available
- = Available
- = Available with exceptions
- ◻ = Untested
- ▶ See specification pages for details.

	Amia 482 Series - FCS, 3D Knit, Standard	Amia 482 Series - FCS, Standard	Amia 482 Series - FCS, 3D Knit, Sewn	Amia 482 Series - FCS, Sewn	cobi 434 Series - FCS, Connect 3D, Standard	cobi 434 Series - FCS, Connect 3D, Sewn	Gesture 442 Series - FCS, Non-Sewn	Gesture 442 Series - FCS, Sewn	Gesture 442 Series - FCS, 3D Knit, Non-Sewn	Jersey 383 Series - FCS, Standard	Jersey 383 Series - FCS, Sewn	Leap 462 Series - FCS, 3D Knit, Standard	Leap 462 Series - FCS, Standard
Nitelights	◻	■	•	•	•	■	•	•	◻	•	•	■	■
Playground	■	■	•	•	•	■	•	•	◻	•	•	■	■
Redeem	■	■	•	•	•	■	•	•	◻	•	•	■	■
Remix	◻	■	•	•	•	■	•	•	◻	•	•	■	■
Reply Air Mesh	•	•	•	•	•	•	•	•	•	•	•	•	•
Retrieve	■	■	•	•	•	■	•	•	◻	•	•	■	■
Seating Vinyl	•	•	•	•	•	■	•	•	◻	•	•	■	•
Silk	◻	•	•	•	•	■	■	■	■	■	•	■	■
Spyder	■	■	•	•	•	■	•	•	◻	•	•	■	■
Stand In	•	•	•	•	•	•	•	•	•	•	•	•	•
Steelcut Trio	◻	■	•	•	•	■	•	•	◻	•	•	■	■
Texel	◻	•	•	•	•	■	•	•	◻	•	•	■	◻

Amia 482 models meet fire code requirements only when specified with fully adjustable arms or armless.
cobi 434 Series fire code models are available in the following Connect 3D colors only: 5021 Blue Jay, 5023 Wasabi, 5025 Graphite, 5026 Licorice, 5027 Malt, and 5028 Root Beer.
Leap 462 models meet fire code requirements only when specified with fully adjustable arms or armless.

Fire Code Seating (FCS) indicates that a product is constructed to meet the strict fire code requirements of high public occupancy areas. For further detail regarding exceptions, see the specific chapter within the *Seating Specification Guide* or the *Surface Materials Reference Manual*.

Legend

- = Not available
- = Available
- = Available with exceptions
- ◻ = Untested
- ▶ See specification pages for details.

	Leap Plus 462 Series - FCS, 3D Knit, Standard	Leap Plus 462 Series - FCS, Standard	Leap 462 Series - FCS, 3D Knit, Sewn	Leap 462 Series - FCS, Sewn	Leap Plus 462 Series - 3D Knit - Sewn	Leap Plus 462 Series - Sewn	Leap 464 WorkLounge and Ottoman Series - FCS	Move 490 Series - FCS	QiVi 428 Series - FCS, QiVi Net, Standard	QiVi 428 Series - FCS, QiVi Net, Sewn	Think 465 Series - 3D Knit Back, Sewn Seat	Think 465 Series - Uph Back, Sewn Seat	Think 465 Series - Sewn Back, Sewn Seat
Nitelights	■	■	•	•	•	•	•	■	■	•	■	■	•
Playground	■	■	•	•	•	•	•	■	■	•	■	■	•
Redeem	■	■	•	•	•	•	•	■	■	•	■	■	•
Remix	■	■	•	•	•	•	•	■	■	■	■	■	•
Reply Air Mesh	•	•	•	•	•	•	•	•	•	•	•	•	•
Retrieve	■	■	•	•	•	•	•	■	■	•	■	■	•
Seating Vinyl	•	•	•	■	■	■	•	■	■	■	□	•	□
Silk	■	■	•	•	•	•	•	■	■	•	■	■	■
Spyder	■	■	•	•	•	•	•	■	■	•	■	■	•
Stand In	•	•	•	•	•	•	•	•	•	•	•	•	•
Steelcut Trio	■	■	•	•	•	•	•	■	■	■	■	■	•
Texel	◻	◻	•	•	•	•	•	■	■	•	■	■	•

Move models meet fire code requirements only when specified with 6205 Black or 6249 Platinum Solid plastic.
Leap 462 models meet fire code requirements only when specified with fully adjustable arms or armless.
Think 465 models meet fire code requirements only when specified with fully adjustable arms or armless.
 Models specified with vinyl meet firecode requirements only when specified armless.

Fire Code Seating with COM

The Fire Code Seating option is available on certain chairs with COM. Fire code approval is based on chair model and specific textile combinations.

To find out if a specific COM is FCS approved on a Steelcase seating product, check the COM website at www.steelcase.com.

Due to the many different combinations of fabric contents and changes that could be made by Steelcase to seating models, fabrics that have been previously approved for fire code may need to be re-tested for qualification.

For complete information about specifying COM on FCS modified chairs, call your Steelcase COM consultant at 616.475.2426 or fax inquiries to: 616.698.4700. Please provide the following information about your COM when making an inquiry:

- Supplier and fabric name
- Flammability testing
- Topical treatments
- Fabric weight
- Fiber content of the fabric
- Seating model number intended for application

FCS Testing

Please submit a COM Application Testing Request form for FCS evaluation prior to sending any fabric. A COM consultant will contact you with more information.

Yardage requirements will vary per chair test. If your material requires FCS testing, submit a completed COM application Testing Request form and material to:

Steelcase Inc.
Attn: COM Testing
Door 305
4060 Eastern Avenue
Grand Rapids, MI 49508

Flame Retardance of COM Fabrics

Steelcase assumes no liability for COM fabrics with a flame-retardant finish and recommends that samples of the fabrics in question be submitted to the proper authority for certification.

If a flame-retardant finish is required, please advise your Steelcase Sales Services representative or regional office of the following information:

- Flammability code that must be passed
- Application of the fabric to be finished (i.e., upholstery, wall, panel, etc.)
- Weight of the fabric
- Need to apply other chemicals to the fabric (i.e., soil repellents)
- Type of backing
- Yardage requirements

With this information, Steelcase can contact the appropriate outside finisher and generate a quote. Treatment prices vary with quantity and fabric selection.

Special Features

This chart provides general guidelines about some of the types of special features that are available.

Legend

- = Not available
- = Available
- S = Standard offering
- ▶ See specification pages for details.

	Different fabric on seat and back	Headrest	Sewn seam using vinyl or leather	Thicker seat cushion	Special seat height *	Special seat height base assemblies for field installation	Stool base	Jury base	Swivel return cylinder	Glides	Soft roll-control casters (specified with chair/stool)	Field-installed roll-control casters	Braking or reverse braking casters	High-performance arm	Oversized tablet arm	Corporate logo
Amia 482 Series	■	•	S	■	■	•	S	■	•	S	•	•	■	S	•	•
Cachet 487 Series	■	•	•	■	■	•	S	■	•	■	S	S	■	•	•	•
cobi 434 Series	■	•	S	•	•	•	S	■	•	S	•	•	■	•	•	•
Criterion 453 Series	■	•	S	■	■	■	S	•	•	S	•	•	■	S	•	•
Gesture 442 Series	■	•	•	•	•	•	•	•	■	•	•	•	•	•	•	•
i2i 416 Series	■	•	•	•	•	•	•	•	■	S	•	•	•	•	•	•
Jersey Series	S	•	•	•	■	■	•	■	•	S	•	•	•	S	•	•
Leap 462 Series	■	S	S	■	■	■	S	■	•	S	•	•	■	S	•	■
Move 490 Series	■	•	•	•	•	•	S	•	•	S	•	•	•	•	•	•
Player 475 Series	■	•	S	•	•	•	•	•	•	S	•	•	•	•	•	•
Protégé 433 Series	•	•	•	■	■	■	■	•	•	■	■	•	■	•	•	•
Reply 466 Series	■	•	•	•	•	■	•	•	•	S	■	•	•	•	•	•
Siento	■	■	S	•	■	•	•	•	•	■	•	•	•	■	•	•
Snodgrass 474 Series	■	•	•	•	•	•	•	•	•	S	•	•	•	•	•	•
Think 465 Series	■	•	S	•	■	•	S	■	•	•	S	S	■	S	•	■

For individual quote information, or special requests not listed above, please submit an RFQ request form. The form may be accessed at the following: <https://village.steelcase.com>, search specialsrfq

*Maximum seat height is 33".
Minimum seat height is 14½" with 3" travel.

Guidelines for Directional Fabrics

What is the issue?

Some textiles are plain and look the same regardless of which direction the fabric is applied to the product. But many customers prefer fabrics that have patterns that give a clear direction to the textile. Because there are limits to how directional fabrics can be applied to panels and chairs, it is important to understand directional fabrics to avoid being disappointed.

Talking about direction

Fabrics come on rolls. The long threads that run parallel to the length of the roll are called the warp. The perpendicular threads that run parallel to the width of the roll are called the filling.

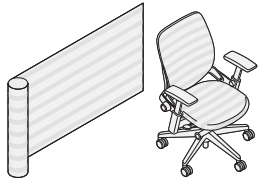

Railroaded means the height dimension of the product is perpendicular to the warp of the fabric; *warp horizontal* and *across roll* are other terms for running the fabric in this direction. All Steelcase standard fabrics are railroaded. The yardage requirements for railroaded cutting are calculated using the width of the fabric, quantity ordered, style of chair(s), and pattern repeat.



Woven way means the height dimension of the product is parallel to the warp of the fabric; *warp vertical* and *down roll* are other terms for running the fabric in this direction. The yardage requirements for woven way cutting are calculated using the width of the fabric, quantity ordered, and style of chair(s).

What determines fabric direction?

The width of the roll of fabric and the techniques that are used to apply it to the product can both determine the direction. Standard default direction for seating products with Steelcase standard fabrics is railroaded. No exceptions are possible. COM fabrics are standard woven way. You may specify a COM fabric to be cut in a specific direction if the product allows it to be applied. The purchase order must clearly state the cutting direction if it is other than standard.

Tip: If you are changing the cutting direction of fabric, yardage requirements may increase, resulting in an additional upcharge. This upcharge will be applied to the purchase order.

▶ See *Yardage Requirements* in the *Surface Materials Reference Manual* for specific information.

If you have any questions regarding cutting direction guidelines, please call the Steelcase Solutions Resource Team at 1.888.STEELCASE or 1.888.783.3522 or send an email to lineone@steelcase.com. You can also find this information on our website:

- Visit www.steelcase.com

COM pattern exceptions

Sometimes COM fabrics have patterns that look awkward or inappropriate if they are applied in the standard direction (woven way). Those cases are addressed with these two pattern exception rules.

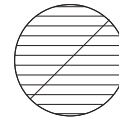

Incorrect

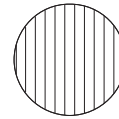

Correct

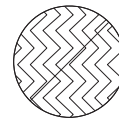

Incorrect

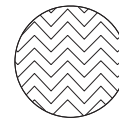

Correct

1

Fabrics with stripes or flame stitch will be applied so that the patterns are vertical.



Incorrect



Correct



Incorrect



Correct

2

Fabrics with patterns of people, vines, or flower arrangements will be applied so that the pattern is vertical.

Approved Fabrics that Meet DFAR 252.225-7012 Preference for Certain Domestic Commodities Used for Navy BPA

Legend

- = Not available
- = Available
- ▶ See specification pages for details.

Price Group		Steelcase Seating	Amia 482 Series Standard Upholstered Seat and Back	Amia 482 Series - Sewn	Brody 488	Cachet 487 Series - Standard	cobi 434 Series - Connect 3D - Standard	cobi 434 Series - Connect 3D - Sewn	Criterion 453 Series - Standard, Molded	Criterion 453 Series - Standard, Plus	Criterion 453 Series - Sewn	Criterion 453 Series - Sewn Back, Sewn Seat	c:scape Cushion Tops	Gesture 442 Series - Non Sewn	i2i 416 Series - 3D Knit - Sewn	Jersey Series - Jersey Mesh - Standard	Jersey Series - Sewn	Kart	Leap 462 Series - 3D Knit Standard	Leap 462 Series Standard	Leap Plus 462 Series - 3D Knit Standard	Leap Plus 462 Series - Standard	Leap 462 Series - 3D Knit - Sewn	Leap 462 Series - Sewn	Leap Plus 462 Series - 3D Knit - Sewn	Leap Plus 462 Series - Sewn	media:scape Lounge	Move 490 Series - Standard	
Steelcase Standard Fabrics																													
Brisa	6		•	■	■	•	•	•	•	■	•	■	■	■	•	■	■	■	■	■	■	•	•	■	■	■	■	■	•
Buzz2	1		■	■	■	■	■	■	■	■	■	■	■	■	■	■	■	■	■	■	■	■	■	■	■	■	■	■	■
Cogent: Connect	2		■	•	■	■	■	■	■	■	■	■	■	■	■	■	■	■	■	■	■	■	■	■	■	■	■	■	■
Cogent: Trails	2		■	•	■	■	■	■	■	■	■	■	■	■	■	■	■	■	■	■	■	■	■	■	■	■	■	■	■
Imperma	3		■	•	■	■	■	■	■	■	■	■	■	■	■	■	■	■	■	■	■	■	■	■	■	■	■	■	■
Jacks	1		■	■	■	■	■	■	■	■	■	■	■	■	■	■	■	■	■	■	■	■	■	■	■	■	■	■	■
Jersey Mesh	Specific to Jersey		•	•	•	•	•	•	•	■	•	•	•	•	•	•	■	•	•	•	•	•	•	•	•	•	•	•	•
Steelcase Leather	Leather Price Group		•	■	■	■	■	■	■	■	■	■	■	■	■	■	■	■	■	■	■	■	■	■	■	■	■	■	■
Link	1		■	■	■	■	■	■	■	■	■	■	■	■	■	■	■	■	■	■	■	■	■	■	■	■	■	■	■
Nitelights	2		■	•	■	■	■	■	■	■	■	■	■	■	■	■	■	■	■	■	■	■	■	■	■	■	■	■	■
Steelcase Vinyl	2		•	■	■	■	■	■	■	■	■	■	■	■	■	■	■	■	■	■	■	■	■	■	■	■	■	■	■
Spyder	2		■	•	•	■	■	■	■	■	■	■	■	■	■	■	■	■	■	■	■	■	■	■	■	■	■	■	■
Texel	3		■	•	■	■	■	■	■	■	■	■	■	■	■	■	■	■	■	■	■	■	■	■	■	■	■	■	■

Tip: 3D knit model numbers 4821418 and 4827418 not available.

For information regarding DesignTex fabrics, please see steelcase.com/customsurfaces.

Approved Fabrics that
Meet DFAR 252.225-7012
Preference for Certain
Domestic Commodities
Used for Navy BPA

Legend

- = Not available
- = Available
- ▶ See specification pages for details.

	Price Group	Steelcase Seating, continued										Steelcase Wood Seating			turnstone Seating				
		Player 475 Series - Standard	Protégé 433 Series - Standard	Protégé 433 Series - Sewn	Reply 466 Series - Guest Sewn	Reply 466 Series - Guest Standard	Reply 466 Series - Sewn (task)	Reply 466 Series - Standard (task)	Siento	Think 465 Series - 3D Knit Back, Sewn Seat	Think 465 Series - Upholstered Back, Sewn Seat	Collaboration	Mingle	Snodgrass	Crew Task	Crew Guest	Jack	Uno	Scoop
Steelcase Standard Fabrics																			
Brisa	6	■	•	■	■	•	■	•	•	■	■	•	•	■	•	■	■	■	■
Buzz2	1	■	■	•	•	•	•	•	■	■	■	■	■	■	■	■	■	■	•
Cogent: Connect	2	■	■	•	•	•	•	•	■	■	■	■	■	■	■	■	■	■	•
Cogent: Trails	2	■	•	•	•	•	•	•	■	■	■	■	■	■	■	■	■	■	•
Imperma	3	■	■	•	•	•	•	•	■	■	■	■	■	■	■	■	■	■	•
Jacks	1	■	■	•	•	•	•	•	■	■	■	■	■	■	■	■	■	■	•
Jersey Mesh	Specific to Jersey	•	•	•	•	•	•	•	•	•	•	•	•	•	•	•	•	•	•
Steelcase Leather	Leather Price Group	•	•	■	■	■	■	■	■	■	■	■	■	■	■	■	■	■	•
Link	1	■	■	•	•	•	•	•	■	■	■	■	■	■	■	■	■	■	•
Nitelights	2	■	■	•	•	•	•	•	■	■	■	■	■	■	■	■	■	■	•
Steelcase Vinyl	2	•	•	■	■	■	■	■	•	■	•	•	■	■	■	•	■	■	•
Spyder	2	■	■	•	•	•	•	•	■	■	■	■	■	■	■	•	■	■	•
Texel	3	■	■	•	•	•	•	•	■	■	■	■	■	■	■	■	■	■	•

*For Think 465 Series with 3D knit back, sewn seat is only available in 3D Knit Black fabric. Must be ordered as a Select Solutions chair using general quote number CH016176 for 3D knit back in Black.

For information regarding DesignTex fabrics, please see steelcase.com/customsurfaces.

Seating

Approved Fabrics that Meet DFAR 252.225-7012 Preference for Certain Domestic Commodities Used for Navy BPA, continued

Legend		Price Group	Steelcase Health	Aspekt	Cura	Leela	Mitra	Jarrah	Regard	Sieste	Sorrel	Tava Guest	Tava Lounge	Empath Recliner	Mineral Recliner	Mitra Recliner	Sieste Sleeper	X-tenz Sleeper	
• = Not available	■ = Available			▶ See specification pages for details.															
Steelcase Standard Fabrics																			
Brisa	6			•	•	•	•	•	■	•	•	■	■	•	•	•	•	•	•
Buzz2	1			■	■	■	■	■	■	■	■	■	■	■	■	■	■	■	■
Cogent: Connect	2			■	■	■	■	■	■	■	■	■	■	■	■	■	■	■	■
Cogent: Trails	2			■	■	■	■	■	■	■	■	■	■	■	■	■	■	■	■
Imperma	3			■	■	■	■	■	■	■	■	■	■	■	■	■	■	■	■
Jacks	1			■	■	■	■	■	■	■	■	■	■	■	■	■	■	■	■
Jersey Mesh	Specific to Jersey			•	•	•	•	•	•	•	•	•	•	•	•	•	•	•	•
Steelcase Leather	Leather Price Group			•	•	•	•	•	•	•	•	•	•	•	•	•	•	•	•
Link	1			■	■	■	■	■	■	■	■	■	■	■	■	■	■	■	■
Nitelights	2			■	■	■	■	■	■	■	■	■	■	■	■	■	■	■	■
Steelcase Vinyl	2			■	■	■	■	■	■	■	■	■	■	■	■	■	■	■	■
Spyder	2			■	■	■	■	■	■	■	■	■	■	■	■	■	■	■	■
Texel	3			■	■	■	■	■	■	■	■	■	■	■	■	■	■	■	■

For information regarding DesignTex fabrics, please see steelcase.com/customsurfaces.

Seating

Approved Fabrics that Meet DFAR 252.225-7012 Preference for Certain Domestic Commodities Used for Navy BPA, continued

Legend

- = Not available
- = Available
- ▶ See specification pages for details.

	Steelcase Seating, continued										Steelcase Wood Seating			turnstone Seating				
	Player 475 Series - Standard	Protégé 433 Series - Standard	Protégé 433 Series - Sewn	Reply 466 Series - Guest Sewn	Reply 466 Series - Guest Standard	Reply 466 Series - Sewn (task)	Reply 466 Series - Standard (task)	Siento	Think 465 Series - 3D Knit Back, Sewn Seat	Think 465 Series - Upholstered Back, Sewn Seat	Collaboration	Mingle	Snodgrass	Crew Task	Crew Guest	Jack	Uno	Scoop
DesignTex Fabrics																		
Acacia	•	•	•	•	■	•	•	•	•	■	■	■	•	•	■	■	■	■
Aksel	■	•	•	•	■	•	■	•	•	■	■	■	■	■	■	■	■	■
Alchemy	■	■	•	•	•	■	•	•	■	■	•	•	■	•	■	•	■	■
Alistair	■	•	•	•	■	•	■	•	■	■	■	■	■	■	■	■	■	■
Alpine	■	•	•	•	■	•	■	■	■	■	■	■	■	■	■	■	■	■
Appleseed	■	■	•	■	■	•	■	■	■	■	■	■	■	■	■	■	■	■
Astrid	■	■	•	•	■	•	■	■	■	■	■	■	■	•	•	•	■	■
Banda	■	•	•	•	■	•	•	•	•	•	■	•	■	•	■	•	•	•
Birch Bark Plaid	■	•	•	•	■	•	■	•	■	■	■	■	■	■	■	■	■	■
Bunta	■	•	•	•	■	•	•	•	•	•	■	•	■	•	■	•	•	•
Cassava	■	•	•	•	■	•	■	•	■	■	■	■	■	•	■	■	•	■
Catalyst	■	•	■	■	•	■	•	•	•	■	•	•	■	•	■	•	■	■
Circa	■	•	•	•	■	•	■	■	■	■	■	■	■	■	■	■	■	■
Circumference	■	•	•	•	■	■	■	•	•	•	■	•	■	•	■	•	•	•
Coco	•	•	•	•	•	•	•	•	•	•	•	•	•	•	•	•	•	•
Coco Plaid	■	•	•	•	■	•	■	■	•	■	■	■	■	■	■	■	■	■
Coco Stripe	■	•	•	•	■	•	•	•	•	•	■	•	■	•	■	•	•	•
Concept	■	■	•	•	■	•	■	•	■	■	■	■	■	■	■	■	•	■
Course	■	•	•	•	■	•	■	•	•	■	■	■	•	■	■	■	■	■
Cross Court	■	•	•	•	■	•	■	•	■	■	■	■	■	■	■	■	•	■
Crossweave	■	•	•	•	■	•	■	■	■	■	■	■	■	■	■	■	■	■
Cut & Paste	■	•	•	•	■	•	■	•	■	■	■	■	■	■	■	■	•	■

*For Think 465 Series with 3D knit back, sewn seat is only available in 3D Knit Black fabric. Must be ordered as a Select Solutions chair using general quote number CH016176 for 3D knit back in Black.

For information regarding DesignTex fabrics, please see steelcase.com/customsurfaces.

Approved Fabrics that Meet DFAR 252.225-7012 Preference for Certain Domestic Commodities Used for Navy BPA

Legend

- = Not available
- = Available
- ▶ See specification pages for details.

	Steelcase Health														
	Aspekt	Cura	Leela	Mitra	Jarrah	Regard	Sieste	Sorrel	Tava Guest	Tava Lounge	Empath Recliner	Mineral Recliner	Mitra Recliner	Sieste Sleeper	X-tenz Sleeper
DesignTex Fabrics															
Acacia	■	■	■	■	■	■	■	■	■	■	■	■	■	■	■
Aksel	■	■	■	■	■	■	■	■	■	■	■	■	■	■	■
Alchemy	■	■	■	■	■	■	■	■	■	■	■	■	■	■	■
Alistair	■	■	■	■	■	■	■	■	■	■	■	■	■	■	■
Alpine	■	■	■	■	■	■	■	■	■	■	■	■	■	■	■
Appleseed	■	■	■	■	■	■	■	■	■	■	■	■	■	■	■
Astrid	■	■	■	■	■	■	■	■	■	■	■	■	■	■	■
Banda	■	•	•	•	•	•	•	■	•	•	•	•	•	•	•
Birch Bark Plaid	■	■	■	■	■	■	■	■	■	■	■	■	■	■	■
Bunta	■	•	•	•	•	•	•	■	•	•	•	•	•	•	•
Cassava	■	■	■	■	■	■	■	■	■	■	■	■	■	■	■
Catalyst	■	■	■	■	■	■	■	■	■	■	■	■	■	■	■
Circa	■	■	■	■	■	■	■	■	■	■	■	■	■	■	■
Circumference	■	•	•	•	•	•	•	■	•	•	•	•	•	•	•
Coco	•	•	•	•	•	•	•	•	•	•	•	•	•	•	•
Coco Plaid	■	■	■	■	■	■	■	■	■	■	■	■	■	■	■
Coco Stripe	■	•	•	•	•	•	•	■	•	•	•	•	•	•	•
Concept	■	■	■	■	■	■	■	■	■	■	■	■	■	■	■
Course	■	■	■	■	■	•	■	■	■	■	■	■	■	■	■
Cross Court	■	■	■	■	■	■	■	■	■	■	■	■	■	■	■
Crossweave	■	■	■	■	■	■	■	■	■	■	■	■	■	■	■
Cut & Paste	■	■	■	■	■	■	■	■	■	■	■	■	■	■	■

For information regarding DesignTex fabrics, please see steelcase.com/customsurfaces.

Approved Fabrics that Meet DFAR 252.225-7012 Preference for Certain Domestic Commodities Used for Navy BPA

Legend

- = Not available
- = Available
- ▶ See specification pages for details.

	Steelcase Seating, continued										Steelcase Wood Seating			turnstone Seating				
	Player 475 Series - Standard	Protégé 433 Series - Standard	Protégé 433 Series - Sewn	Reply 466 Series - Guest Sewn	Reply 466 Series - Guest Standard	Reply 466 Series - Sewn (task)	Reply 466 Series - Standard (task)	Siento	Think 465 Series - 3D Knit Back, Sewn Seat	Think 465 Series - Upholstered Back, Sewn Seat	Collaboration	Mingle	Snodgrass	Crew Task	Crew Guest	Jack	Uno	Scoop
DesignTex Fabrics																		
Dart	■	•	•	•	■	•	■	•	■	■	■	■	■	■	■	■	•	■
Divide	■	•	•	•	■	•	•	•	•	•	■	•	•	•	■	•	•	•
Draft	■	•	•	•	■	•	■	•	•	■	■	■	■	■	■	■	•	■
Eon	■	•	■	■	•	■	•	•	■	■	•	•	■	•	■	•	•	■
Flux	■	•	•	•	■	•	■	•	■	■	■	■	■	■	■	■	•	■
Gamut	•	•	•	•	•	•	•	■	•	•	■	■	•	■	■	■	■	■
Glaze	•	•	•	•	•	•	•	•	•	•	•	•	•	•	•	•	•	•
Gleam	■	•	•	•	■	•	•	•	•	•	■	•	■	•	■	•	•	•
Gradate	■	•	•	•	■	•	•	•	•	•	■	•	■	•	■	•	•	•
Hatchmark	•	•	•	•	•	•	•	•	•	•	•	•	•	•	•	•	•	•
Hexstripe	■	•	•	•	■	•	■	•	■	■	■	■	■	■	■	■	•	■
Honor Plus	■	•	•	•	■	•	■	■	■	■	■	■	■	•	■	•	■	■
Inertia	■	•	•	•	■	•	■	•	■	■	■	■	■	■	■	■	•	■
Inertia Loomstate	•	•	•	•	•	•	•	•	•	•	•	•	•	•	•	•	•	•
Inkling	■	•	•	•	■	•	■	•	■	■	■	■	•	■	■	■	•	■
Jaunt	■	•	•	•	■	•	■	•	■	■	■	■	■	■	■	■	•	■
Journey	■	•	■	■	•	■	•	•	■	■	•	•	■	•	■	•	■	■
Klange	■	■	•	•	■	•	■	■	■	■	■	■	■	■	■	■	•	■
Latitude	■	•	•	■	•	•	•	•	•	•	■	•	■	•	■	•	•	•
Lattice	■	•	•	•	■	•	■	•	■	■	■	■	■	■	■	■	•	■
Leaf Dot	■	•	•	•	■	•	•	•	•	•	■	•	■	•	■	•	•	•
Leland	■	■	•	•	■	•	■	•	■	■	■	■	■	■	■	■	■	■
Little Plaid	■	•	•	•	■	•	•	•	•	•	■	•	■	•	■	•	•	•
Lofty	■	•	•	•	■	•	■	■	■	■	■	■	■	■	■	■	■	■

*For Think 465 Series with 3D knit back, sewn seat is only available in 3D Knit Black fabric. Must be ordered as a Select Solutions chair using general quote number CH016176 for 3D knit back in Black.

For information regarding DesignTex fabrics, please see steelcase.com/customsurfaces.

Seating

Approved Fabrics that Meet DFAR 252.225-7012 Preference for Certain Domestic Commodities Used for Navy BPA, continued

Legend

- = Not available
- = Available
- ▶ See specification pages for details.

	Steelcase Health														
	Aspekt	Cura	Leela	Mitra	Jarrah	Regard	Sieste	Sorrel	Tava Guest	Tava Lounge	Empath Recliner	Mineral Recliner	Mitra Recliner	Sieste Sleeper	X-tenz Sleeper
DesignTex Fabrics															
Dart	■	■	■	■	■	■	■	■	■	■	■	■	■	■	■
Divide	■	•	•	•	•	•	•	■	•	•	•	•	•	•	•
Draft	■	■	■	■	■	■	■	■	■	■	■	■	■	■	■
Eon	■	■	■	■	■	■	■	■	■	■	■	■	■	■	■
Flux	■	■	■	■	■	■	■	■	■	■	■	■	■	■	■
Gamut	■	■	■	■	■	■	■	■	■	■	■	■	■	■	■
Glaze	•	•	•	•	•	•	•	•	•	•	•	•	■	•	•
Gleam	■	•	•	•	•	•	•	■	•	•	•	•	•	•	•
Gradate	■	•	•	•	•	•	•	■	•	•	•	•	•	•	•
Hatchmark	•	•	•	•	■	•	■	•	•	•	■	•	•	■	•
Hexstripe	■	■	■	■	■	■	■	■	■	■	■	■	■	■	■
Honor Plus	■	■	■	■	■	■	■	■	■	■	■	■	■	■	■
Inertia	■	■	■	■	■	■	■	■	■	■	■	■	■	■	■
Inertia Loomstate	•	•	•	•	•	•	•	•	•	•	•	•	•	•	•
Inkling	■	■	■	■	■	■	■	■	■	■	■	■	■	■	■
Jaunt	■	■	■	■	■	■	■	■	■	■	■	■	■	■	■
Journey	■	■	■	■	■	■	■	■	■	■	■	■	■	■	■
Klange	■	■	■	■	■	■	■	■	■	■	■	■	■	■	■
Latitude	•	•	•	•	•	•	•	•	•	•	•	•	•	•	•
Lattice	■	■	■	■	■	■	■	■	■	■	■	■	■	■	■
Leaf Dot	■	•	•	•	•	•	•	■	•	•	•	•	•	•	•
Leland	■	■	■	■	■	■	■	■	■	■	■	■	■	■	■
Little Plaid	■	•	•	•	•	•	•	■	■	•	•	•	•	•	•
Lofty	■	■	■	■	■	■	■	■	■	■	■	■	■	■	■

For information regarding DesignTex fabrics, please see steelcase.com/customsurfaces.

Approved Fabrics that Meet DFAR 252.225-7012 Preference for Certain Domestic Commodities Used for Navy BPA

Legend

- = Not available
- = Available
- ▶ See specification pages for details.

	Steelcase Seating																										
	Amia 482 Series Standard Upholstered Seat and Back	Amia 482 Series - Sewn	Brody 488	Cachet 487 Series - Standard	cobi 434 Series - Connect 3D - Standard	cobi 434 Series - Connect 3D - Sewn	Criterion 453 Series - Standard, Molded	Criterion 453 Series - Standard, Plus	Criterion 453 Series - Sewn	Criterion 453 Series - Sewn Back, Sewn Seat	c:scape Cushion Tops	Gesture 442 Series - Non Sewn	i2i 416 Series - 3D Knit - Sewn	Jersey Series - Jersey Mesh - Standard	Jersey Series - Sewn	Kart	Leap 462 Series - 3D Knit Standard	Leap 462 Series Standard	Leap Plus 462 Series - 3D Knit Standard	Leap Plus 462 Series - Standard	Leap 462 Series - 3D Knit - Sewn	Leap 462 Series - Sewn	Leap Plus 462 Series - 3D Knit - Sewn	Leap Plus 462 Series - Sewn	media:scape Lounge	Move 490 Series - Standard	
DesignTex Fabrics																											
Mandala	■	■	•	■	•	■	■	■	•	■	■	■	■	■	•	■	■	■	■	■	■	■	■	■	■	■	■
Majolica with backing	■	■	■	•	•	■	■	■	•	■	■	■	■	■	•	■	■	■	■	■	■	■	■	■	■	■	■
Metamorphosis	•	•	•	•	•	•	•	•	•	•	■	•	•	•	•	•	•	•	•	•	•	•	•	■	■	•	•
Metamorphosis with backing	•	■	■	■	•	■	•	■	•	■	■	■	■	■	•	■	■	■	■	■	■	■	■	■	■	■	■
Migration	•	•	•	•	•	•	•	•	•	•	■	•	•	•	•	•	•	•	•	•	•	•	•	■	■	•	•
Migration with backing	•	■	■	■	•	■	•	■	•	■	■	■	■	■	•	■	■	■	■	■	■	■	■	■	■	■	■
Mod	■	■	•	•	•	■	•	■	•	■	■	■	■	■	•	■	■	■	■	■	■	■	■	■	■	■	■
Motif	■	■	•	•	•	■	■	■	•	■	■	■	■	■	•	■	■	■	■	■	■	■	■	■	■	■	■
Nexus	■	■	■	•	•	■	■	■	•	■	■	■	■	■	•	■	■	■	■	■	■	■	■	■	■	■	■
Nonchalant	■	•	•	■	•	•	■	•	■	•	■	•	•	■	•	■	■	■	■	■	■	■	■	■	■	■	■
Notion	■	■	■	■	•	■	■	■	•	■	■	■	■	■	•	■	■	■	■	■	■	■	■	■	■	■	■
Omar	■	■	■	■	•	■	■	■	•	■	■	■	■	■	•	■	■	■	■	■	■	■	■	■	■	■	■
Oscillate	■	■	■	•	•	■	■	■	•	■	■	■	■	■	•	■	■	■	■	■	■	■	■	■	■	■	■
Oscillate Loomstate	•	•	•	•	•	•	•	•	•	•	•	•	•	•	•	•	•	•	•	•	•	•	•	•	•	•	•
Phase	•	■	•	■	•	■	•	■	•	■	■	■	■	■	•	■	■	■	■	■	■	■	■	■	■	■	■
Pinball	■	■	•	•	•	■	•	■	•	■	■	■	■	■	•	■	■	■	■	■	■	■	■	■	■	■	■
Pinpoint	■	■	•	•	•	■	■	■	•	■	■	■	■	■	•	■	■	■	■	■	■	■	■	■	■	■	■
Pleat	•	■	■	•	•	■	•	■	•	■	■	■	■	■	•	■	■	■	■	■	■	■	■	■	■	■	■
Pop Art	■	■	•	•	•	■	■	■	•	■	■	■	■	■	•	■	■	■	■	■	■	■	■	■	■	■	■
Posey	•	■	•	•	•	■	•	■	•	■	■	■	■	■	•	■	■	■	■	■	■	■	■	■	■	■	■
Prompt	■	•	•	•	•	■	•	■	•	■	■	■	■	■	•	■	■	■	■	■	■	■	■	■	■	■	■
Quintessence	•	■	■	•	•	■	•	■	•	■	■	■	■	■	•	■	■	■	■	■	■	■	■	■	■	■	■
Rail	■	•	•	•	•	■	•	■	•	■	■	■	■	■	•	■	■	■	■	■	■	■	■	■	■	■	■
Rice	•	■	■	•	•	■	•	■	•	■	■	■	■	■	•	■	■	■	■	■	■	■	■	■	■	■	■

Tip: 3D knit model numbers 4821418 and 4827418 not available.

For information regarding DesignTex fabrics, please see steelcase.com/customsurfaces.

Seating

Approved Fabrics that Meet DFAR 252.225-7012 Preference for Certain Domestic Commodities Used for Navy BPA, continued

Legend

- = Not available
- = Available
- ▶ See specification pages for details.

	Steelcase Seating, continued										Steelcase Wood Seating			turnstone Seating				
	Player 475 Series - Standard	Protégé 433 Series - Standard	Protégé 433 Series - Sewn	Reply 466 Series - Guest Sewn	Reply 466 Series - Guest Standard	Reply 466 Series - Sewn (task)	Reply 466 Series - Standard (task)	Siento	Think 465 Series - 3D Knit Back, Sewn Seat	Think 465 Series - Upholstered Back, Sewn Seat	Collaboration	Mingle	Snodgrass	Crew Task	Crew Guest	Jack	Uno	Scoop
DesignTex Fabrics																		
Mandala	■	•	•	•	■	•	■	•	■	■	■	■	■	■	■	■	■	■
Majolica with backing	■	•	•	•	•	•	•	•	■	■	■	■	■	■	■	■	•	■
Metamorphosis	•	•	•	•	•	•	•	•	•	•	•	•	•	•	•	•	•	•
Metamorphosis with backing	■	•	■	■	•	■	•	•	■	■	•	•	■	•	■	•	■	■
Migration	•	•	•	•	•	•	•	•	•	•	•	•	•	•	•	•	•	•
Migration with backing	■	•	■	■	•	■	•	•	■	■	•	•	■	•	■	•	■	■
Mod	■	•	•	•	■	•	■	•	■	■	■	■	■	■	■	■	•	■
Motif	■	•	•	•	■	•	■	•	■	■	■	■	■	■	■	■	•	■
Nexus	■	•	•	•	■	•	■	•	■	■	■	■	■	■	■	■	•	■
Nonchalant	■	■	•	•	■	•	•	•	•	•	■	•	■	•	•	•	•	•
Notion	■	•	•	•	■	•	■	■	■	■	■	■	■	■	■	■	■	■
Omar	•	•	•	•	■	•	■	•	■	■	■	■	■	■	■	■	■	■
Oscillate	■	•	•	•	■	•	■	■	■	■	■	■	■	■	■	■	•	■
Oscillate Loomstate	•	•	•	•	•	•	•	•	•	•	•	•	•	•	•	•	•	•
Phase	■	•	■	■	•	■	•	•	■	■	•	•	■	•	■	•	■	■
Pinball	■	•	•	•	■	•	■	•	■	■	■	■	■	■	■	■	•	■
Pinpoint	■	•	•	•	■	•	■	•	■	■	■	■	■	■	■	■	•	■
Pleat	■	•	•	•	■	•	■	■	■	■	■	■	■	■	■	■	■	■
Pop Art	■	•	•	•	■	•	■	•	■	■	■	■	■	■	■	■	•	■
Posey	■	•	•	•	■	•	■	•	■	■	■	■	■	•	■	■	•	■
Prompt	■	•	•	•	■	•	■	•	•	•	■	•	•	•	■	•	•	•
Quintessence	■	•	•	•	■	•	■	■	■	■	■	■	■	•	■	■	■	■
Rail	■	•	•	•	■	•	•	•	•	•	■	•	■	•	■	•	•	•
Rice	■	•	•	•	■	•	•	■	■	■	■	■	■	•	■	■	•	■

*For Think 465 Series with 3D knit back, sewn seat is only available in 3D Knit Black fabric. Must be ordered as a Select Solutions chair using general quote number CH016176 for 3D knit back in Black.

For information regarding DesignTex fabrics, please see steelcase.com/customsurfaces.

Approved Fabrics that
Meet DFAR 252.225-7012
Preference for Certain
Domestic Commodities
Used for Navy BPA

Legend

- = Not available
- = Available
- ▶ See specification pages for details.

	Steelcase Health														
	Aspekt	Cura	Leela	Mitra	Jarrah	Regard	Sieste	Sorrel	Tava Guest	Tava Lounge	Empath Recliner	Mineral Recliner	Mitra Recliner	Sieste Sleeper	X-tenz Sleeper
DesignTex Fabrics															
Mandala	■	■	■	■	■	■	■	■	■	■	■	■	■	■	■
Majolica with backing	■	■	■	■	■	■	■	■	■	■	■	■	■	■	■
Metamorphosis	•	•	•	•	•	•	•	•	•	•	•	•	•	•	•
Metamorphosis with backing	■	■	■	■	■	■	■	■	■	■	■	■	■	■	■
Migration	•	•	•	•	•	•	•	•	•	•	•	•	•	•	•
Migration with backing	■	■	■	■	■	■	■	■	■	■	■	■	■	■	■
Mod	■	■	■	■	■	■	■	■	■	■	■	■	■	■	■
Motif	■	■	■	■	■	■	■	■	■	■	■	■	■	■	■
Nexus	■	■	■	■	■	■	■	■	■	■	■	■	■	■	■
Nonchalant	■	•	•	•	•	•	•	■	•	•	•	•	•	•	•
Notion	■	■	■	■	■	■	■	■	■	■	■	■	■	■	■
Omar	■	■	■	■	■	■	■	■	■	■	■	■	■	■	■
Oscillate	■	■	■	■	■	■	■	■	■	■	■	■	■	■	■
Oscillate Loomstate	•	•	•	•	•	•	•	•	•	•	•	•	•	•	•
Phase	■	■	■	■	■	■	■	■	■	■	■	■	■	■	■
Pinball	■	■	■	■	■	•	■	•	■	■	■	■	■	■	■
Pinpoint	■	■	■	■	■	•	■	■	■	■	■	■	■	■	■
Pleat	■	■	■	■	■	■	■	■	■	■	■	■	■	■	■
Pop Art	■	■	■	■	■	■	■	■	■	■	■	■	■	■	■
Posey	■	■	■	■	■	■	■	■	■	■	■	■	■	■	■
Prompt	■	•	•	•	•	•	•	■	•	•	•	•	•	•	•
Quintessence	■	■	■	■	■	■	■	■	■	■	■	■	■	■	■
Rail	■	•	•	•	•	•	•	■	•	•	•	•	•	•	•
Rice	■	■	■	■	■	■	■	■	■	■	■	■	•	■	■

For information regarding DesignTex fabrics, please see steelcase.com/customsurfaces.

Seating

Approved Fabrics that Meet DFAR 252.225-7012 Preference for Certain Domestic Commodities Used for Navy BPA, continued

Legend

- = Not available
- = Available
- ▶ See specification pages for details.

	Steelcase Seating																										
	Amia 482 Series Standard Upholstered Seat and Back	Amia 482 Series - Sewn	Brody 488	Cachet 487 Series - Standard	cobi 434 Series - Connect 3D - Standard	cobi 434 Series - Connect 3D - Sewn	Criterion 453 Series - Standard, Molded	Criterion 453 Series - Standard, Plus	Criterion 453 Series - Sewn	Criterion 453 Series - Sewn Back, Sewn Seat	c:scape Cushion Tops	Gesture 442 Series - Non Sewn	i2i 416 Series - 3D Knit - Sewn	Jersey Series - Jersey Mesh - Standard	Jersey Series - Sewn	Kart	Leap 462 Series - 3D Knit Standard	Leap 462 Series Standard	Leap Plus 462 Series - 3D Knit Standard	Leap Plus 462 Series - Standard	Leap 462 Series - 3D Knit - Sewn	Leap 462 Series - Sewn	Leap Plus 462 Series - 3D Knit - Sewn	Leap Plus 462 Series - Sewn	media:scape Lounge	Move 490 Series - Standard	
DesignTex Fabrics																											
Rocket	■	•	■	■	•	■	■	■	•	■	■	■	■	■	•	■	■	■	■	■	■	■	■	■	■	■	■
Rotary	■	■	•	•	•	■	■	■	■	■	■	■	■	■	■	■	■	■	■	■	■	■	■	■	■	■	■
Rothesay	■	•	•	■	•	■	■	■	■	■	■	■	■	■	■	■	■	■	■	■	■	■	■	■	■	■	■
Rothesay with backing	■	■	■	■	•	■	■	■	■	■	■	■	■	■	■	■	■	■	■	■	■	■	■	■	■	■	■
Round Leaves	■	■	■	•	•	■	■	■	■	■	■	■	■	■	■	■	■	■	■	■	■	■	■	■	■	■	■
See Saw	•	■	•	•	•	■	•	■	•	■	■	■	■	■	■	■	■	■	■	■	■	■	■	■	■	■	■
Seed	•	■	•	•	•	■	•	■	•	■	■	■	■	■	■	■	■	■	■	■	■	■	■	■	■	■	■
Shibori Stripe	■	■	■	■	•	■	■	■	■	■	■	■	■	■	■	■	■	■	■	■	■	■	■	■	■	■	■
Shimmering Tide with knit backing	■	■	■	•	■	■	■	■	■	■	■	■	■	■	■	■	■	■	■	■	■	■	■	■	■	■	■
Signal	•	■	•	•	•	■	•	■	•	■	■	■	■	■	■	■	■	■	■	■	■	■	■	■	■	■	■
Strand	•	■	•	■	•	■	•	■	•	■	■	■	■	■	■	■	■	■	■	■	■	■	■	■	■	■	■
Striae	•	■	■	■	•	■	•	■	•	■	■	■	■	■	■	■	■	■	■	■	■	■	■	■	■	■	■
Sugar Shoots	•	•	•	•	•	■	•	■	•	■	■	■	■	■	■	■	■	■	■	■	■	■	■	■	■	■	■
Swing	■	•	•	•	•	■	•	■	•	■	■	■	■	■	■	■	■	■	■	■	■	■	■	■	■	■	■
Tangle	•	•	•	•	•	•	•	•	•	•	•	•	•	•	•	•	•	•	•	•	•	•	•	•	•	•	•
Tetris	■	■	•	•	•	■	■	■	■	■	■	■	■	■	■	■	■	■	■	■	■	■	■	■	■	■	■
The Last Aphid	■	■	•	•	•	■	■	■	■	■	■	■	■	■	■	■	■	■	■	■	■	■	■	■	■	■	■
Tramway	■	•	•	•	•	■	•	■	•	■	■	■	■	■	■	■	■	■	■	■	■	■	■	■	■	■	■
Transport	■	■	•	•	•	■	■	■	■	■	■	■	■	■	■	■	■	■	■	■	■	■	■	■	■	■	■
Tumble Stones	•	■	■	■	•	■	•	■	•	■	■	■	■	■	■	■	■	■	■	■	■	■	■	■	■	■	■
Tumble Stones with backing	•	■	■	■	•	■	•	■	•	■	■	■	■	■	■	■	■	■	■	■	■	■	■	■	■	■	■
Tumbleweed	•	■	■	•	•	■	•	■	•	■	■	■	■	■	■	■	■	■	■	■	■	■	■	■	■	■	■
Turn	•	■	•	•	•	■	■	■	■	■	■	■	■	■	■	■	■	■	■	■	■	■	■	■	■	■	■
Vivid	■	■	■	■	•	■	■	■	■	■	■	■	■	■	■	■	■	■	■	■	■	■	■	■	■	■	■
Whim	■	■	■	■	•	■	•	■	•	■	■	■	■	■	■	■	■	■	■	■	■	■	■	■	■	■	■
Windowpane	•	•	•	•	•	•	•	•	•	•	■	•	•	■	•	•	•	•	•	•	•	•	•	•	•	•	■
Woodcut	■	■	■	•	•	■	■	■	■	■	■	■	■	■	■	■	■	■	■	■	■	■	■	■	■	■	■
Yucca	■	•	•	•	•	■	■	■	■	■	■	■	■	■	■	■	■	■	■	■	■	■	■	■	■	■	■

Tip: 3D knit model numbers 4821418 and 4827418 not available

For information regarding DesignTex fabrics, please see steelcase.com/customsurfaces.

Approved Fabrics that Meet DFAR 252.225-7012 Preference for Certain Domestic Commodities Used for Navy BPA

Legend

- = Not available
- = Available
- ▶ See specification pages for details.

	Steelcase Seating										Steelcase Wood Seating			turnstone Seating				
	Player 475 Series - Standard	Protégé 433 Series - Standard	Protégé 433 Series - Sewn	Reply 466 Series - Guest Sewn	Reply 466 Series - Guest Standard	Reply 466 Series - Sewn (task)	Reply 466 Series - Standard (task)	Siento	Think 465 Series - 3D Knit Back, Sewn Seat	Think 465 Series - Upholstered Back, Sewn Seat	Collaboration	Mingle	Snodgrass	Crew Task	Crew Guest	Jack	Uno	Scoop
DesignTex Fabrics																		
Rocket	■	•	•	•	■	•	■	■	■	■	■	■	■	■	■	■	■	■
Rotary	■	•	•	•	■	•	■	■	■	■	■	■	■	■	■	■	■	■
Rothesay	■	■	•	•	■	•	■	■	■	■	■	■	■	■	■	■	■	■
Rothesay with backing	■	■	•	•	■	•	■	■	■	■	■	■	■	■	■	■	■	■
Round Leaves	■	•	•	•	■	•	■	■	■	■	■	■	■	■	■	■	■	■
See Saw	■	•	•	•	■	•	■	■	■	■	■	■	■	■	■	■	■	■
Seed	■	•	•	•	■	•	■	■	■	■	■	■	■	■	■	■	■	■
Shibori Stripe	■	•	•	•	■	•	■	■	■	■	■	■	■	■	■	■	■	■
Shimmering Tide with knit backing	■	•	•	•	■	•	■	■	■	■	■	■	■	■	■	■	■	■
Signal	■	•	•	•	■	•	■	■	■	■	■	■	■	■	■	■	■	■
Strand	■	•	■	■	•	■	•	■	■	■	■	■	■	■	■	■	■	■
Striae	■	•	•	•	■	•	■	■	■	■	■	■	■	■	■	■	■	■
Sugar Shoots	■	•	•	•	■	•	■	■	■	■	■	■	■	■	■	■	■	■
Swing	•	•	•	•	■	•	■	■	■	■	■	■	■	■	■	■	■	■
Tangle	•	•	•	•	■	•	■	■	■	■	■	■	■	■	■	■	■	■
Tetris	■	•	•	•	■	•	■	■	■	■	■	■	■	■	■	■	■	■
The Last Aphid	■	•	•	•	■	•	■	■	■	■	■	■	■	■	■	■	■	■
Tramway	■	•	•	•	■	•	■	■	■	■	■	■	■	■	■	■	■	■
Transport	■	•	•	•	■	•	■	■	■	■	■	■	■	■	■	■	■	■
Tumble Stones	■	•	■	■	•	■	•	■	■	■	■	■	■	■	■	■	■	■
Tumble Stones with backing	■	•	■	■	•	■	•	■	■	■	■	■	■	■	■	■	■	■
Tumbleweed	■	•	•	•	■	•	■	■	■	■	■	■	■	■	■	■	■	■
Turn	■	•	•	•	■	•	■	■	■	■	■	■	■	■	■	■	■	■
Vivid	■	•	•	•	■	•	■	■	■	■	■	■	■	■	■	■	■	■
Whim	■	■	•	•	■	•	■	■	■	■	■	■	■	■	■	■	■	■
Windowpane	■	•	•	•	■	•	■	■	■	■	■	■	■	■	■	■	■	■
Woodcut	■	•	•	•	■	•	■	■	■	■	■	■	■	■	■	■	■	■
Yucca	■	•	•	•	■	•	■	■	■	■	■	■	■	■	■	■	■	■

*For Think 465 Series with 3D knit back, sewn seat is only available in 3D Knit Black fabric. Must be ordered as a Select Solutions chair using general quote number CH016176 for 3D knit back in Black.

For information regarding DesignTex fabrics, please see steelcase.com/customsurfaces.

Seating

Approved Fabrics that Meet DFAR 252.225-7012 Preference for Certain Domestic Commodities Used for Navy BPA, continued

Legend

- = Not available
- = Available
- ▶ See specification pages for details.

	Steelcase Health														
	Aspekt	Cura	Leela	Mitra	Jarrah	Regard	Sieste	Sorrel	Tava Guest	Tava Lounge	Empath Recliner	Mineral Recliner	Mitra Recliner	Sieste Sleeper	X-tenz Sleeper
Designtex Fabrics															
Rocket	■	■	■	■	■	■	■	■	■	■	■	■	■	■	■
Rotary	■	■	■	■	■	■	■	■	■	■	■	■	■	■	■
Rothesay	■	•	•	•	•	•	•	•	•	•	•	•	•	•	•
Rothesay with backing	■	■	■	■	■	■	■	■	■	■	■	■	■	■	■
Round Leaves	■	■	■	■	■	■	■	■	■	■	■	■	■	■	■
See Saw	■	■	■	■	■	■	■	■	■	■	■	■	■	■	■
Seed	■	■	■	■	■	■	■	■	■	■	■	■	■	■	■
Shibori Stripe	■	■	■	■	■	■	■	■	■	■	■	■	■	■	■
Shimmering Tide with knit backing	•	■	■	■	■	■	■	■	■	■	■	■	■	•	■
Signal	■	■	■	■	■	■	■	■	■	■	■	■	■	■	■
Strand	■	■	■	■	■	•	■	■	■	■	■	■	■	■	■
Striae	■	■	■	■	■	■	■	■	■	■	■	■	■	■	■
Sugar Shoots	■	•	•	•	•	•	•	■	•	•	•	•	•	•	•
Swing	■	•	•	•	•	•	•	■	•	•	•	•	•	•	•
Tangle	•	•	•	•	•	•	•	•	•	•	•	•	•	•	•
Tetris	■	■	■	■	■	■	■	■	■	■	■	■	■	■	■
The Last Aphid	■	■	■	■	■	■	■	■	■	■	■	■	■	■	■
Tramway	■	•	•	•	•	•	•	■	•	•	•	•	•	•	•
Transport	■	■	■	■	■	■	■	■	■	■	■	■	■	■	■
Tumble Stones	■	■	■	■	■	■	■	■	■	■	■	■	■	■	■
Tumble Stones with backing	■	■	■	■	■	■	■	■	■	■	■	■	■	■	■
Tumbleweed	■	■	■	■	■	■	■	■	■	■	■	■	■	■	■
Turn	■	■	■	■	■	■	■	■	■	■	■	■	■	■	■
Vivid	■	■	■	■	■	■	■	■	■	■	■	■	■	■	■
Whim	■	■	■	■	■	■	■	■	■	■	■	■	■	■	■
Windowpane	■	•	•	•	•	•	•	■	•	•	•	•	•	•	•
Woodcut	■	■	■	■	■	■	■	■	■	■	■	■	■	■	■
Yucca	■	•	•	•	•	•	•	■	•	•	•	•	•	•	•

For information regarding DesignTex fabrics, please see steelcase.com/customsurfaces.

Vertical Surfaces Fabric Applications

Legend

- = Not available
- = Available
- ▶ See specification pages for details.

	Price Group	Roll Width	Answer	Avenir	Brody Lounge Seating – Lower Surround	Brody Lounge Seating – Seat	Brody Lounge Seating – Screen	Brody Lounge Seating – Footrest	Divisio Side Screen	Flex Screens	FlexFrame	FrameOne	Groupwork Screens	Kick Panels	Montage	Ology Universal Screen	Privacy Wall	Sarto Screens	Umami Screens	Universal Privacy/Modesty Screens
Steelcase Fabrics																				
Alloy	1	66"	■	■	■	■	■	■	■	■	■	■	■	■	■	•	•	■	•	•
Bouquet	2	66"	■	■	■	■	■	■	■	■	■	•	■	■	■	•	■	■	•	•
Buzz2	1	54"	■	■	■	■	■	■	■	■	■	■	■	■	■	■	■	■	■	■
Code	2	66½"	■	■	•	•	•	•	■	■	■	■	■	■	■	■	■	■	■	■
Flip: Orbit	2	66"	■	■	■	■	■	■	■	■	■	•	■	•	■	•	■	■	•	•
Flip: TexHex	2	66"	■	■	■	■	■	■	■	■	•	■	•	■	•	■	■	•	•	•
Fresco	2	66"	■	■	■	■	■	■	■	■	■	•	■	■	■	•	■	■	•	•
Lapel	1	66"	■	■	■	■	■	■	■	■	■	•	■	■	■	•	•	■	•	•
Latch	2	66"	■	■	•	•	•	•	■	■	■	■	■	■	■	■	■	■	■	■
Milano	2	66"	■	■	■	■	■	■	■	■	■	•	■	■	■	•	■	■	•	•
Optic	1	66"	■	■	■	■	■	■	■	■	■	•	■	■	■	•	■	■	•	•
Rhythm	1	66"	■	■	■	■	■	■	■	■	■	•	■	■	■	•	■	■	•	•
Sprite	A	66"	■	•	■	■	■	■	•	■	•	•	■	■	•	•	■	■	•	•
DesignTex Fabrics																				
Appleseed Unfinished	-	-	•	•	•	•	•	•	•	•	■	•	•	•	•	•	•	•	■	•
Cesta	-	-	■	■	•	•	•	•	■	■	■	■	■	■	■	•	■	■	•	•
Clew	-	-	■	■	•	•	•	•	■	■	■	■	■	■	■	•	•	■	•	•
Decibel	-	-	■	■	•	•	•	•	■	■	■	■	■	■	■	■	■	■	■	■
Gamut Unfinished	-	-	■	■	•	•	•	•	■	■	■	■	■	■	■	■	■	■	■	•
Gravity	-	-	■	■	•	•	•	•	■	■	■	■	•	■	■	•	■	■	•	•
New Brunswick	-	-	■	■	•	■	•	■	•	■	■	■	■	■	■	•	•	■	•	•
Plateau	-	-	■	■	•	•	•	•	■	■	■	■	■	■	■	•	■	■	•	•
Rocket without Nanotex	-	-	■	•	•	•	•	•	■	•	■	■	■	■	■	•	•	•	■	•
Singing In The Rain	-	-	■	■	•	•	•	•	■	■	■	■	■	■	■	•	•	■	•	•
Vivid Unfinished	-	-	■	■	•	•	•	•	■	■	■	■	■	■	■	•	■	■	•	•

turnstone 1.0 Seating



Statement of Line **488**



Specifying

Crew (SIN 711.18) **490**

Uno (SIN 711.18) **496**



Surface Materials **498**

Statement of Line

turnstone 1.0 Seating

Crew



Task Chair
with Arms
▶ Page 490



Task Chair
without Arms
▶ Page 490



Stool
with Arms
▶ Page 490

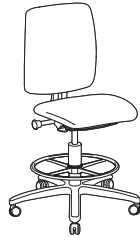

Stool
without Arms
▶ Page 490

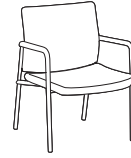

Guest Chair
with Arms
▶ Page 493



Guest Chair
without Arms
▶ Page 493

Uno



Multi-Purpose
High-Back Chair
▶ Page 496

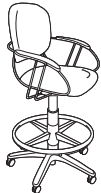

Multi-Purpose
High-Back Stool
▶ Page 496



Multi-Purpose
Mid-Back Chair
▶ Page 496

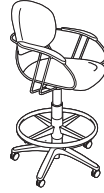

Multi-Purpose
Mid-Back Stool
▶ Page 496

Crew

SIN 711.18

Task Chairs and Stools with Foot Rings



Tip: Hard dual-wheel casters are for use on carpet. Use on hard surfaces, including floor mats, will affect chair stability and may result in personal injury.

Tip: Leather (L suffix) uses a sewn upholstery process on the seat which produces a stitched detail.

Tip: Vinyl specified with a V suffix uses a sewn upholstery process on the seat which produces a stitched detail. Vinyl specified without a suffix is a non-sewn, seamless upholstery process and is available at no additional cost.

Tip: Arms, if specified, will match base.

Tip: Suffixes other than K for contrasting fabric, will be added in alphabetical order when specifying options. The contrasting fabric suffix, K, will always be at the end of the style number.

Standard Includes	Required to Specify
<ul style="list-style-type: none"> • Synchro-tilt mechanism • Pneumatic seat height • Upright back lock • Tilt tension • Back height adjustment • Upholstered seat and inner back: fabric price group 1 • Outer back: black plastic • Five-arm base: black plastic • Width-adjustable arms, if arms selected: 0835 Black • Adjustable foot ring on stools only: 9201 Polished Chrome • Hard dual-wheel casters: black • Shipped ready to assemble with no tools required 	<ol style="list-style-type: none"> 1 Style number 2 Fabric color number for upholstery 3 Options, if selected (see below) <p>▶ See <i>Surface Materials</i>, page 498.</p>

Surface Materials	Options	Price	Required to Specify
	Upholstery on seat and back		
	<ul style="list-style-type: none"> • Fabric price group 1 • Fabric price group 2 • Fabric price group 3 • Fabric price group 4 • Fabric price group 5 • Fabric price group 6 • Fabric price group 7 • Fabric price group 8 • Fabric price group 9 • Fabric price group 10 • Leather price group 	<ul style="list-style-type: none"> No cost +\$ 26 +\$ 48 +\$ 68 +\$ 85 +\$106 +\$121 +\$153 +\$188 +\$213 +\$476 	<ul style="list-style-type: none"> Specify fabric color number. Specify fabric color number. Specify fabric color number. Specify fabric color number. Specify fabric color number. Specify fabric color number. Specify fabric color number. Specify fabric color number. Specify fabric color number. Specify fabric color number. Specify fabric color number. Add suffix L to style number and specify leather color number. Add suffix V to style number and specify vinyl color number.
	<ul style="list-style-type: none"> • Sewn Vinyl 	<ul style="list-style-type: none"> +\$ 77 	<ul style="list-style-type: none"> ▶ See <i>Surface Materials Reference Manual</i>.
	<ul style="list-style-type: none"> • Customer's Own Material/Vinyl (COM) • Customer's Own Leather (COL) 	<ul style="list-style-type: none"> +\$ 37 +\$ 77 	<ul style="list-style-type: none"> Add suffix L to style number and specify leather color number.
	Outer back		
	<ul style="list-style-type: none"> • Upholstered outer back 	<ul style="list-style-type: none"> +\$101 	<ul style="list-style-type: none"> Add suffix U to the style number.
	Base on task chairs		
	<ul style="list-style-type: none"> • Aluminum base: 4799 Platinum 	<ul style="list-style-type: none"> +\$ 60 	<ul style="list-style-type: none"> Specify <i>with 4799 Platinum</i>.
	Contrasting upholstery on seat and back		
	<ul style="list-style-type: none"> • Contrasting fabrics 	<ul style="list-style-type: none"> +\$ 31 	<ul style="list-style-type: none"> Add suffix K to the style number and specify fabric color numbers.
	Contrasting upholstery on seat		
	<ul style="list-style-type: none"> • Fabric price group 1 • Fabric price group 2 • Fabric price group 3 • Fabric price group 4 • Fabric price group 5 • Fabric price group 6 • Fabric price group 7 • Fabric price group 8 • Fabric price group 9 • Fabric price group 10 • Leather price group 	<ul style="list-style-type: none"> No cost +\$ 13 +\$ 24 +\$ 34 +\$ 42 +\$ 53 +\$ 60 +\$ 76 +\$ 94 +\$106 +\$238 	<ul style="list-style-type: none"> Specify fabric color number. Specify fabric color number. Specify fabric color number. Specify fabric color number. Specify fabric color number. Specify fabric color number. Specify fabric color number. Specify fabric color number. Specify fabric color number. Specify fabric color number. Specify fabric color number. Add suffix L to style number and specify leather color number.
	<ul style="list-style-type: none"> • Customer's Own Material/Vinyl (COM) • Customer's Own Leather (COL) 	<ul style="list-style-type: none"> +\$ 18 No cost 	<ul style="list-style-type: none"> ▶ See <i>Surface Materials Reference Manual</i>. Add suffix L to style number and specify leather color number.

▶ Options, continued on next page

► Options, continued from previous page

Options	Price	Required to Specify
Surface Materials, continued	Contrasting upholstery on back	
• Fabric price group 1	No cost	Specify fabric color number.
• Fabric price group 2	+\$ 13	Specify fabric color number.
• Fabric price group 3	+\$ 24	Specify fabric color number.
• Fabric price group 4	+\$ 34	Specify fabric color number.
• Fabric price group 5	+\$ 43	Specify fabric color number.
• Fabric price group 6	+\$ 53	Specify fabric color number.
• Fabric price group 7	+\$ 61	Specify fabric color number.
• Fabric price group 8	+\$ 77	Specify fabric color number.
• Fabric price group 9	+\$ 94	Specify fabric color number.
• Fabric price group 10	+\$107	Specify fabric color number.
• Leather price group	+\$238	Add suffix L to style number and specify leather color number.
• Own Material/Vinyl (COM)	+\$ 19	► See <i>Surface Materials Reference Manual</i> .
• Customer's Own Leather (COL)	No cost	Add suffix L to style number and specify leather color number.
Casters	• Soft dual-wheel casters for use on hard floors	No cost
		Specify <i>with soft casters</i> .
Glides	• Non-marring plastic glides	+\$ 31
		Specify <i>with glides</i> .

Specification Information

Style Number	Base Price
--------------	------------

Full-Back Task Chairs

Armless

TS30801 \$624

With Fixed-Height T-Arms

TS30811 \$715

With Height- and Width-Adjustable T-Arms

TS30821 \$752

With Height-, Width-, and Pivot-Adjustable Arms

TS30831 \$818



Tip: Arms, if specified, will match base.

Full-Back Task Chairs with Seat Depth

Armless

TS30802 \$693

With Fixed-Height T-Arms

TS30812 \$784

With Height- and Width-Adjustable T-Arms

TS30822 \$821

With Height-, Width-, and Pivot-Adjustable Arms

TS30832 \$887



Tip: Arms, if specified, will match base.

► Specification Information, continued on next page

SIN 711.18

► Specification Information, continued from previous page

Specification Information

• Style	• Base
• Number	• Price
:	:
:	:

Full-Back Task Stools

Armless

TS30803 \$785

With Fixed-Height T-Arms

TS30813 \$876

With Height- and Width-Adjustable T-Arms

TS30823 \$913

With Height-, Width-, and Pivot-Adjustable Arms

TS30833 \$979

:



Tip: Arms and base available in black only.

Guest Chairs



Tip: Hard dual-wheel casters are for use on carpet. Use on hard surfaces, including floor mats, will affect chair stability and may result in personal injury.

*Tip: When specifying wood back and leather seat, specify suffix **W** before suffix **L**.
Example: TS30805WL.*

*Tip: When specifying wood back and vinyl seat, specify suffix **W** before suffix **V**.
Example: TS30806WV.*

Standard Includes	Required to Specify
<ul style="list-style-type: none"> ▶ Need help? See <i>Seating Specification Guide</i> for product details. • Upholstered seat and back: fabric price group 1 • Steel four-leg frame: 7207 Black • Hard dual-wheel casters or glides: black • Shipped fully assembled • Stacks four high 	<ul style="list-style-type: none"> 1 Style number 2 Fabric color number for upholstery 3 Options, if selected (see below) ▶ See <i>Surface Materials</i>, page 498.

Options	Price	Required to Specify
Surface Materials		
Single upholstery fabric		
• Fabric price group 1	No cost	Specify fabric color number.
• Fabric price group 2	+\$ 26	Specify fabric color number.
• Fabric price group 3	+\$ 48	Specify fabric color number.
• Fabric price group 4	+\$ 68	Specify fabric color number.
• Fabric price group 5	+\$ 85	Specify fabric color number.
• Fabric price group 6	+\$106	Specify fabric color number.
• Fabric price group 7	+\$121	Specify fabric color number.
• Fabric price group 8	+\$153	Specify fabric color number.
• Fabric price group 9	+\$188	Specify fabric color number.
• Fabric price group 10	+\$213	Specify fabric color number.
• Leather price group	+\$452	Specify fabric color number.
• Vinyl	No cost	Add suffix L to style number and specify leather color number.
• Customer's Own Material/ Vinyl (COM)	+\$ 37	Add suffix V to style number and specify vinyl color number. ▶ See <i>Surface Materials Reference Manual</i> .
Upholstery on chair with wood back		
• Fabric price group 1	No cost	Specify fabric color number.
• Fabric price group 2	+\$ 10	Specify fabric color number.
• Fabric price group 3	+\$ 26	Specify fabric color number.
• Fabric price group 4	+\$ 35	Specify fabric color number.
• Fabric price group 5	+\$ 42	Specify fabric color number.
• Fabric price group 6	+\$ 51	Specify fabric color number.
• Fabric price group 7	+\$ 62	Specify fabric color number.
• Fabric price group 8	+\$ 77	Specify fabric color number.
• Fabric price group 9	+\$ 94	Specify fabric color number.
• Fabric price group 10	+\$109	Specify fabric color number.
• Leather price group	+\$161	Specify fabric color number.
• Vinyl	No cost	Add suffix L to style number and specify leather color number.
• Customer's Own Material/ Vinyl (COM)	+\$ 37	Add suffix V to style number and specify vinyl color number. ▶ See <i>Surface Materials Reference Manual</i> .
Multiple upholstery fabric		
• Different fabric on seat and back	+\$ 65	Add suffix M to chair style number and select fabric color number for:
▶ See below and at right.		<ol style="list-style-type: none"> 1 Seat 2 Back <i>Example: TS30805M with T015 on seat and T016 on back.</i>
1 Fabric on seat		
• Fabric price group 1	No cost	Specify fabric color number.
• Fabric price group 2	+\$ 10	Specify fabric color number.
• Fabric price group 3	+\$ 26	Specify fabric color number.
• Fabric price group 4	+\$ 35	Specify fabric color number.
• Fabric price group 5	+\$ 42	Specify fabric color number.
• Fabric price group 6	+\$ 51	Specify fabric color number.
• Fabric price group 7	+\$ 62	Specify fabric color number.
• Fabric price group 8	+\$ 77	Specify fabric color number.
• Fabric price group 9	+\$ 94	Specify fabric color number.
• Fabric price group 10	+\$109	Specify fabric color number.
• Customer's Own Material (COM)	+\$ 37	Specify fabric color number. ▶ See <i>Surface Materials Reference Manual</i> .

▶ **Options, continued on next page**

Uno

SIN 711.18

Multi-Purpose Chairs



Tip: Frame is available in black only.

Tip: Hard dual-wheel casters are for use on carpet. Use on hard surfaces, including floor mats, will affect chair stability and may result in personal injury.

Tip: When specifying multiple COM fabrics, indicate all surfaces where COM applies. Example: TS31101M with Designtex 1234 on seat and Designtex 5678 on back.

Standard Includes	Required to Specify
<ul style="list-style-type: none"> ▶ Need help? See <i>Seating Specification Guide</i> for product details. • Hammock-style support • Swivel mechanism • Pneumatic height adjustment • Upholstered seat and back: fabric price group 1 • Outer back: black plastic • Five-arm base: reinforced black plastic • Hard dual-wheel casters: black • Stool ring, if selected: black paint • Shipped ready to assemble with no tools required 	<ul style="list-style-type: none"> 1 Style number 2 Fabric color number for upholstery 3 Options, if selected (see below) ▶ See <i>Surface Materials</i>, page 498.

Options	Price	Required to Specify
Surface Materials <ul style="list-style-type: none"> • Single upholstery fabric • Fabric price group 1 No cost • Fabric price group 2 +\$ 26 • Fabric price group 3 +\$ 48 • Fabric price group 4 +\$ 68 • Fabric price group 5 +\$ 85 • Fabric price group 6 +\$106 • Fabric price group 7 +\$121 • Fabric price group 8 +\$153 • Fabric price group 9 +\$188 • Fabric price group 10 +\$213 • Leather price group +\$275 • Customer's Own Material (COM) +\$ 37 • Customer's Own Leather (COL) +\$ 62 • Multiple upholstery fabric • Different fabric on seat and back +\$ 65 ▶ See below and at right. ① Fabric on seat • Fabric price group 1 No cost • Fabric price group 2 +\$ 10 • Fabric price group 3 +\$ 26 • Fabric price group 4 +\$ 35 • Fabric price group 5 +\$ 42 • Fabric price group 6 +\$ 51 • Fabric price group 7 +\$ 62 • Fabric price group 8 +\$ 77 • Fabric price group 9 +\$ 94 • Fabric price group 10 +\$109 • Leather price group +\$138 • Customer's Own Material (COM) +\$ 16 • Customer's Own Leather (COL) +\$ 32 		<ul style="list-style-type: none"> Specify fabric color number. Specify fabric color number. Specify fabric color number. Specify fabric color number. Specify fabric color number. Specify fabric color number. Specify fabric color number. Specify fabric color number. Specify fabric color number. Specify fabric color number. Specify leather color number. ▶ See <i>Surface Materials Reference Manual</i>. Specify leather color number. Add suffix M to chair style number and select fabric color number for: <ul style="list-style-type: none"> ① Seat ② Back Example: TS31101M with T015 on seat and T016 on back. Specify fabric color number. Specify fabric color number. Specify fabric color number. Specify fabric color number. Specify fabric color number. Specify fabric color number. Specify fabric color number. Specify fabric color number. Specify fabric color number. Specify leather color number. ▶ See <i>Surface Materials Reference Manual</i>. Specify leather color number.
▶ Options, continued on next page		

► Options, continued from previous page

Options	Price	Required to Specify
Surface Materials, continued ② Fabric on back <ul style="list-style-type: none"> Fabric price group 1 Fabric price group 2 Fabric price group 3 Fabric price group 4 Fabric price group 5 Fabric price group 6 Fabric price group 7 Fabric price group 8 Fabric price group 9 Fabric price group 10 Leather price group Customer's Own Material (COM) Customer's Own Leather (COL) 	<ul style="list-style-type: none"> No cost +\$ 10 +\$ 26 +\$ 35 +\$ 42 +\$ 51 +\$ 62 +\$ 77 +\$ 94 +\$109 +\$138 +\$ 16 +\$ 32 	<ul style="list-style-type: none"> Specify fabric color number. Specify fabric color number. Specify fabric color number. Specify fabric color number. Specify fabric color number. Specify fabric color number. Specify fabric color number. Specify fabric color number. Specify fabric color number. Specify fabric color number. Specify leather color number. ► See <i>Surface Materials Reference Manual</i>. Specify leather color number.
Stool Kit <ul style="list-style-type: none"> Stool kit with swivel mechanism 	<ul style="list-style-type: none"> +\$197 	<ul style="list-style-type: none"> Specify <i>with stool kit</i>.
Casters <ul style="list-style-type: none"> Soft dual-wheel casters for use on hard floors 	<ul style="list-style-type: none"> No cost 	<ul style="list-style-type: none"> Specify <i>with soft casters</i>.
Glides <ul style="list-style-type: none"> Non-marring plastic glides 	<ul style="list-style-type: none"> +\$ 31 	<ul style="list-style-type: none"> Specify <i>with glides</i>.

Specification Information

Style Number	Base Price
--------------	------------

Mid-Back Multi-Purpose Chair

TS31101 \$549



High-Back Multi-Purpose Chair

TS31102 \$638



Surface Materials

Paint

Steelcase Surfaces

Applies to:

- Crew guest chair

7207 Black

Applies to:

- Crew arms

0835 Black

Applies to:

- Crew base, arms, and frame

4799 Platinum Metallic

Plastic

Steelcase Surfaces

Applies to:

- Crew task chair outer back and base

6205 Black

Wood

Steelcase Surfaces

Applies to:

- Crew guest wood back

3412 Natural Cherry
3522 Clear Maple
3762 Dark Walnut

Tip: Due to natural variations in wood, finished products may vary in color, texture, and grain.

Upholstery

Steelcase Surfaces

Not every upholstery is available on every chair. Please refer to the upholstery matrix on page 499 before specifying.

Price Group 1

Buzz2
Era
Jacks
Link
Playground

Price Group 2

Chainmail
Cogent: Connect
Cogent: Trails
Nitelights
Seating Vinyl
Spyder
Stand In

Price Group 3

Billiard Multi-Use by Designtex
Gaja — Cradle to Cradle Certified™ Silver
Imperma
Redeem
Retrieve
Texel

Price Group 5

Bo Peep
Remix
Silk

Price Group 6

Brisa

Leather

Steelcase Surfaces

Applies to:

- Crew

L107 Black
L202 Dusk
L207 Mahogany
L220 Soapstone
L221 Rocky
L507 Vineyard

Select Surfaces

For information on products within Select Surfaces, including accent paints and fabrics from Designtex, Gabriel, Kvadrat, and Pollack, please refer to the *Surface Materials Reference Manual* or visit www.steelcase.com/surface-materials under the Select Surfaces section.

Custom Surfaces

Customer's Own Material (COM) Program

The Customer's Own Material (COM) program offers the opportunity for customers to select fabrics that are not offered through the standard Steelcase surface materials program for use on Steelcase products. Once approved, you can place your order. Steelcase will facilitate the entire ordering process and give you a production schedule. Steelcase will order the COM fabric directly from the textile manufacturer. For up-to-date information regarding fabric test results for all COM fabrics and details regarding yardage requirements for most seating lines, visit the COM website on www.steelcase.com. COMs are not covered under the Steelcase warranty.

Soil Retardants

Soil retardants are treatments that provide long-term soil and stain resistance to a fabric without affecting the shade or the integrity of the fabric. The following Steelcase Textiles and turnstone Collection by Designtex fabrics are available pre-treated with soil retardant:

- Jacks
- Link
- Spyder

For information on soil retardant fabrics on select surfaces, please refer to the *Surface Materials Reference Manual*.

Seating Upholstery Matrix

turnstone 1.0

Legend

- = Not available
- = Available
- = Available with exceptions
- ▣ = COM approved
- ▶ See *Surface Materials* and Specifying pages.
- *Gaja — Cradle to Cradle Certified™ Silver

	Price Group	á la carte - Standard, Task	á la carte - Standard, Guest	Crew - Standard, Task, Plastic Back	Crew - Standard, Task, Upholstered Back	Crew - Standard, Guest, Upholstered Back	Crew - Standard, Guest, Wood Back	Pedestal Seat Cushion - Standard	Uno - Standard	Uno - Standard, High Back
Billiard Multi-Use by DesignTex	3	■	■	■	■	■	■	■	■	■
Bo Peep	5	■	■	■	■	■	■	■	■	■
Brisa	6	■	■	■	•	■	■	■	■	■
Buzz2	1	■	■	■	■	■	■	■	■	■
Chainmail	2	■	■	■	■	■	■	■	■	■
Cogent: Connect	2	■	■	■	■	■	■	■	■	■
Cogent: Geode Vertical	2	•	•	■	■	•	•	■	■	■
Cogent: Trails	1	■	■	■	■	■	■	■	■	■
Era	1	■	■	■	■	■	■	■	■	■
Gaja*	3	■	■	■	■	■	■	■	■	■
Imperma	3	■	■	■	■	■	■	■	■	■
Jacks	1	■	■	■	■	■	■	■	■	■
turnstone Leather	NA	•	•	•	•	•	•	•	•	•
Steelcase Leather	L	▣	▣	■	■	■	■	▣	■	■
Link	1	■	■	■	■	■	■	■	■	■

Surface Materials

Seating Upholstery Matrix, turnstone 1.0, continued

SIN 711.18

Legend

- = Not available
- = Available
- = Available with exceptions
- (grey) = COM approved
- ▶ See *Surface Materials* and *Specifying* pages.

	Price Group	á la carte - Standard, Task	á la carte - Standard, Guest	Crew - Standard, Task, Plastic Back	Crew - Standard, Task, Upholstered Back	Crew - Standard, Guest, Upholstered Back	Crew - Standard, Guest, Wood Back	Pedestal Seat Cushion - Standard	Uno - Standard	Uno - Standard, High Back
New Black: Bruce	1	■	■	■	■	■	■	■	■	■
New Black: Harley	2	■	■	■	■	■	■	■	■	■
New Black: Henry	1	■	■	■	■	■	■	■	■	■
New Black: Jack	2	■	■	■	■	■	■	■	■	■
New Black: James	2	■	■	■	■	■	■	■	■	■
Nitelights	2	■	■	■	■	■	■	■	■	■
Playground	1	■	■	■	■	■	■	■	■	■
Redeem	3	■	■	■	■	■	■	■	■	■
Remix	5	■	■	■	■	■	■	■	■	■
Reply Air Mesh	NA	■	■	■	■	■	■	■	•	•
Retrieve	3	■	■	■	■	■	■	■	■	■
Seating Vinyl	2	■	■	■	•	■	•	■	■	■
Silk	5	■	■	■	■	■	■	■	■	■
Spyder	2	■	■	■	■	■	■	■	■	■
Stand In	2	■	■	■	■	■	■	■	■	■
Steelcut Trio	7	■	■	■	■	■	■	■	■	■
Texel	3	■	■	■	■	■	■	■	■	■

Resources

Style Number Index

502

Resources

Style Number Index

Style Number	Page	Description
120	407	Collaboration Guest Chair
120D	407	Collaboration Guest Chair
120L	407	Collaboration Guest Chair
120U	407	Collaboration Guest Chair
126900	350	Kart Accessory
126A100	349	Kart Nesting Chair
126A101	349	Kart Nesting Chair
126A111	359	Kart Leg-Base Stacking Chair
126A200	350	Kart Nesting Chair
126A200S	349	Kart Nesting Chair
126A201	350	Kart Nesting Chair
126A201S	349	Kart Nesting Chair
126A211	359	Kart Leg-Base Stacking Chair
126A211S	359	Kart Leg-Base Stacking Chair
126B100ST	353	Kart Stool
126B101ST	353	Kart Stool
126B111ST	357	Kart Café Leg-Base Stool
126B200SST	354	Kart Stool
126B200ST	354	Kart Stool
126B201SST	353	Kart Stool
126B201ST	354	Kart Stool
126B211SST	357	Kart Café Leg-Base Stool
126B211ST	357	Kart Café Leg-Base Stool
127C100J	361	Kart Jury Base Chair
127C101J	361	Kart Jury Base Chair
127C200J	362	Kart Jury Base Chair
127C200SJ	362	Kart Jury Base Chair
127C201J	362	Kart Jury Base Chair
127C201SJ	361	Kart Jury Base Chair
128C100J	362	Kart Jury Base Chair
128C101J	362	Kart Jury Base Chair
128C200J	363	Kart Jury Base Chair
128C200SJ	363	Kart Jury Base Chair
128C201J	363	Kart Jury Base Chair
128C201SJ	362	Kart Jury Base Chair
416911	342	i2i 416 Work Chair
416911T	342	i2i 416 Work Chair/Tab
428310	219	Qivi 428 Sled-Base Multi-Use Chair
428510	216	Qivi 428 Collab Chair
428710	217	Qivi 428 Collab Stool
428910	219	Qivi 428 Sled-Base Multi-Use Chair
4331203	189	Protégé 433 Work Chair
4331223	189	Protégé 433 Work Chair
4331403	189	Protégé 433 Work Chair
4331423	189	Protégé 433 Work Chair
4333003	191	Protégé 433 Guest Chair
4333023	191	Protégé 433 Guest Chair
4335023	192	Protégé 433 Sled-Base Guest Chair
434110	225	cobi 434 Work Chair
434111	225	cobi 434 Work Chair/Arm
434710	227	cobi 434 Work Stool
434711	227	cobi 434 Work Stool/Arm
435A00	120	Steelcase Series 1 Work Chair
435B00	121	Steelcase Series 1 Stool
435COATHANGER	122	Steelcase Series 1 Hanger

Style Number	Page	Description
435HEADREST	122	Steelcase Series 1 Headrest
442A30	39	Gesture 442 Shell Bck Chair
442A40	39	Gesture 442 Wrapped Bck Chair
442A50	41	Gesture 442 Series Wrk Chr w/Headrest
442B30	43	Gesture 442 Shell Bck Stool
442B40	43	Gesture 442 Wrapped Bck Stool
4535300	88	Criterion 453 MidBk Work Chair
4535300D	88	Criterion 453 MidBk Work Chair
4535301	84	Criterion 453 HiBk Work Chair
4535301D	84	Criterion 453 HiBk Work Chair
4535330	88	Criterion 453 MidBk Work Chair
4535330D	88	Criterion 453 MidBk Work Chair
4535330DP	88	Criterion 453 MidBk Work Chair
4535330DW	88	Criterion 453 MidBk Work Chair
4535330P	88	Criterion 453 MidBk Work Chair
4535330W	88	Criterion 453 MidBk Work Chair
4535331	84	Criterion 453 HiBk Work Chair
4535331D	84	Criterion 453 HiBk Work Chair
4535331DP	84	Criterion 453 HiBk Work Chair
4535331DW	84	Criterion 453 HiBk Work Chair
4535331P	84	Criterion 453 HiBk Work Chair
4535331W	84	Criterion 453 HiBk Work Chair
4537300	96	Criterion 453 MidBk Stool
4537300D	96	Criterion 453 MidBk Stool
4537301	92	Criterion 453 HiBk Stool
4537301D	92	Criterion 453 HiBk Stool
4537330	96	Criterion 453 MidBk Stool
4537330D	96	Criterion 453 MidBk Stool
4537330DP	96	Criterion 453 MidBk Stool
4537330DW	96	Criterion 453 MidBk Stool
4537330P	96	Criterion 453 MidBk Stool
4537330W	96	Criterion 453 MidBk Stool
4537331	92	Criterion 453 HiBk Stool
4537331D	92	Criterion 453 HiBk Stool
4537331DP	92	Criterion 453 HiBk Stool
4537331DW	92	Criterion 453 HiBk Stool
4537331P	92	Criterion 453 HiBk Stool
4537331W	92	Criterion 453 HiBk Stool
4539301B	99	Criterion Plus 453 HiBk Work Chair
4539331B	99	Criterion Plus 453 HiBk Work Chair
4539331BW	99	Criterion Plus 453 HiBk Work Chair
46216179	52	Leap 462 Work Chair
46216189	55	Leap 462 Work Chair
46267179	58	Leap 462 Stool
46267189	61	Leap 462 Stool
46296179	64	Leap Plus 462 Work Chair
46296189	67	Leap Plus 462 Work Chair
465A000	109	Think 465 Series Work Chair
465A300	107	Think 465 Series Work Chair
465B000	113	Think 465 Series Stool
465B300	110	Think 465 Series Stool
466160MP	161	Reply 466 Series Work Chair
466160MT	159	Reply 466 Series Work Chair
466450MH	165	Reply 466 Series Leg-Base Multi-Use Chair
466450MT	163	Reply 466 Series Leg-Base Multi-Use Chair

Style Number	Page	Description	Style Number	Page	Description
466452MH	165	Reply 466 Series Leg-Base Multi-Use Chair	4827418	147	Amia 482 Series Stool
466452MT	163	Reply 466 Series Leg-Base Multi-Use Chair	4871110	199	Cachet 487 Swivel-Base
466480MH	169	Reply 466 Series Sled-Base Multi-Use Chair	4871210	199	Cachet 487 Swivel-Base
466480MT	166	Reply 466 Series Sled-Base Multi-Use Chair	4871211	199	Cachet 487 Swivel-Base
466482MH	169	Reply 466 Series Sled-Base Multi-Use Chair	4877110	203	Cachet 487 Stool
466482MT	166	Reply 466 Series Sled-Base Multi-Use Chair	4877210	203	Cachet 487 Stool
472BR	429	Max-Stkr 472 Bkrack Assy	4877211	203	Cachet 487 Stool
472G	430	Max-Stkr 472 Alignment Device	4878100	201	Cachet 487 Leg-Base
472TAL	429	Max-Stkr 472 Tablet Arm Assy	4878110	201	Cachet 487 Leg-Base
472TAR	429	Max-Stkr 472 Tablet Arm Assy	4878200	201	Cachet 487 Leg-Base
473D	430	Max-Stkr Trans/Strg Dolly	4878201	201	Cachet 487 Leg-Base
474410M	403	Snodgrass 474 Series Chair	4878210	201	Cachet 487 Leg-Base
474419M	403	Snodgrass 474 Series Chair	4878211	201	Cachet 487 Leg-Base
474419W	403	Snodgrass 474 Guest Chair	487BK	206	Cachet 487 Cushion Upholstery Pkg
475410M	369	Player 475 Leg-Base Multi-Purp Chair	487D	208	Cachet 487 Transport/Strg Dolly
475410MTL	371	Player 475 Leg-Base Multi-Purp Chair	487G	208	Cachet 487 Ganging/Alignment Device
475410MTR	371	Player 475 Leg-Base Multi-Purp Chair	487ST	207	Cachet 487 Cushion Upholstery Pkg
475412M	369	Player 475 Leg-Base Multi-Purp Chair	487STBK	205	Cachet 487 Cushion Upholstery Pkg
475412MC	369	Player 475 Leg-Base Multi-Purp Chair	488BD	271	Brody Privacy Desk
475415M	369	Player 475 Leg-Base Multi-Purp Chair	488BDE	273	Brody Privacy Desk with Extension
475415MC	369	Player 475 Leg-Base	488FR	274	Brody Footrest
475480M	373	Player 475 Sled-Base	488WE	268	Brody Privacy Lounge with Extension
475480MTL	375	Player 475 Sled-Base	488WO	261	Brody WorkLounge
475480MTR	375	Player 475 Sled-Base	488WP	264	Brody Privacy Lounge
475482M	373	Player 475 Sled-Base	490410	387	Move 490
475485M	373	Player 475 Sled-Base	490410C	387	Move 490
475710M	377	Player 475 Leg-Base Stool	490410CP	388	Move 490
475712M	377	Player 475 Leg-Base Stool	490410P	388	Move 490
475715M	377	Player 475 Leg-Base Stool	490410U	388	Move 490
475A	378	Player 475 Alignment Device	490410UC	388	Move 490
475D	378	Player 475 Transport/Strg Dolly	490410V	384	Move 490
475G	378	Player 475 Ganging Device	490410VC	384	Move 490
477100	428	Max-Stacker III 477 Series Stackable Chair	490412	388	Move 490
480110	235	Node 480 Series Work Chair	490412C	388	Move 490
480120	235	Node 480 Series Work Chair	490412CP	388	Move 490
480130	237	Node 480 Series Collaborative Chair	490412P	388	Move 490
480140	242	Node 480 Series Collaborative Stool	490412U	388	Move 490
480150	237	Node 480 Series Collaborative Chair	490412UC	388	Move 490
480170	235	Node 480 Series Collaborative Chair	490412V	384	Move 490
480180	237	Node 480 Series Collaborative Chair	490412VC	384	Move 490
480210	239	Node 480 Series MidBk Collab Chair	490510	395	Move 490 Perching Stool
480220	239	Node 480 Series MidBk Collab Chair	490510P	396	Move 490 Perching Stool
480230	241	Node 480 Series MidBk Collab Chair	490510U	395	Move 490 Perching Stool
480240	243	Node 480 Series MidBk Collab Stool	490512	396	Move 490 Perching Stool
480250	241	Node 480 Series MidBk Collab Chair	490512P	396	Move 490 Perching Stool
480270	239	Node 480 Series MidBk Collab Chair	490512U	396	Move 490 Perching Stool
480280	241	Node 480 Series MidBk Collab Chair	490710	391	Move 490
4821410	134	Amia 482 Series Work Chair	490710C	391	Move 490
4821410LS	130	Amia 482 Series Work Chair	490710CP	392	Move 490
4821412	139	Amia 482 Series Air Back Work Chair	490710P	392	Move 490
4821414	141	Amia 482 Series Air Back Work Chair	490710U	391	Move 490
4821418	137	Amia 482 Series Chair	490710UC	391	Move 490
4827410	144	Amia 482 Series Stool	490710V	385	Move 490 Value Pkg
4827412	149	Amia 482 Series Air Back Stool	490710VC	385	Move 490 Value Pkg
4827414	151	Amia 482 Series Air Back Stool	490712	392	Move 490

Style Number Index, continued

Style Number	Page	Description
490712C	392	Move 490
490712CP	392	Move 490
490712P	392	Move 490
490712U	392	Move 490
490712UC	392	Move 490
490712V	385	Move 490 Value Pkg
490712VC	385	Move 490 Value Pkg
490D	397	Move Transport/Storage Dolly
490WS	397	Wall Saver
499111	74	Siento Mid-Back Desk Chair
499112	74	Siento Mid-Back Desk Chair
499113	74	Siento Mid-Back Desk Chair
499121	74	Siento Mid-Back Desk Chair
499122	74	Siento Mid-Back Desk Chair
499123	74	Siento Mid-Back Desk Chair
499211	74	Siento High-Back Desk Chair
499212	74	Siento High-Back Desk Chair
499213	74	Siento High-Back Desk Chair
499221	74	Siento High-Back Desk Chair
499222	74	Siento High-Back Desk Chair
499223	74	Siento High-Back Desk Chair
499SIENTO	70	Siento Design Pkg High-Back Chair
CQCT1632	343	Collaborative Lounge Table
JERSEYV	174	Jersey Series Value Work Chair
MNGLB	410	Mingle Guest Chair
N3LCABLE	337	B-Free Cable Riser
N3LCUBEL	328	B-Free Large Cube
N3LCUBES	329	B-Free Small Cube
N3LGA	330	B-Free Ganging Brackets
N3LMAGSC	332	B-Free Screen to Cube Magnets
N3LMAGSS	332	B-Free Screen to Screen Magnets
N3LPINT	336	Pint Tables
N3LRECT	335	Rectangle Tables
N3LSCREEN	331	B-Free Screen
N3LTABLECF	333	B-Free Occasional Coffee Table
N3LTABLECR	333	B-Free Occasional Corner Table
PROTEGEV	186	Protégé 433 Value Work Chair
STLLNG2AR2	305	Umami Lounge, Two Arms, Double
STLLNGAR1	301	Umami Lounge, One Arm, Single
STLLNGAR2	303	Umami Lounge, One Arm, Double
STLLNGCR1	307	Umami Lounge, Corner, Single
STLLNGEC	309	Umami Lounge, End Cap
STLLNGST1	297	Umami Straight Lounge, Single
STLLNGST2	299	Umami Straight Lounge, Double
STLPLTF1	290	Umami Single Platform
STLPLTF2	294	Umami Double Platform
STLSCRPL	315	Umami Screens, Standard
STLSCRPLS	320	Umami Screens, Spanner Screens
TS30801	491	Crew Chair
TS30802	491	Crew Chair
TS30803	492	Crew Stool
TS30805	494	Crew Chair
TS30806	494	Crew Chair
TS30807	494	Crew Chair
TS30808	494	Crew Chair

Style Number	Page	Description
TS30811	491	Crew Chair
TS30812	491	Crew Chair
TS30813	492	Crew Stool
TS30821	491	Crew Chair
TS30822	491	Crew Chair
TS30823	492	Crew Stool
TS30831	491	Crew Chair
TS30832	491	Crew Chair
TS30833	492	Crew Stool
TS31101	497	Uno Chair
TS31102	497	Uno Chair
TS38301	177	Jersey Chair
TS38304	179	Jersey Chair
TS38305	179	Jersey Chair
TS38308	181	Jersey Chair
TS38309	181	Jersey Chair
WHG6600	417	Nooi Linking Chair, Armless
WHG6602	417	Nooi Linking Chair, Arms
WHG6604	419	Nooi Sled-Based Chair
WHG6606	421	Nooi Cafeteria Chair, Armless
WHG6608	421	Nooi Cafeteria Chair, Arms
WHG6625	423	Nooi Bar-Height Stool
WHG6626	423	Nooi Cafe-Height Stool

Trademark List

- The following are registered trademarks for products of Steelcase Inc. or one of its related corporate entities: 4 o'clock, 900 Series, à la carte, Airtouch, Ally, Amia, Answer, Archipelago, Avenir, Ballet, Bix, Brayton International, Cachet, Canopy, Canto, Chancellor, Coalesse, Confidante, Context, Convene, CopyCam, Criterion, Crushed Can, Currency, dash, Designtex, Details, Detour, Drive, Elective Elements, Ellipse, Ember Chrome, Emerge, E-Table 2, FYI, Garland, Gentry, Ginkgo Biloba, Groupwork, Ideo, Jacket, Jenny, Jersey, Kart, Kick, LaCosta, Leap, Let's B, LiveBack, Max-Stacker, media:scape, Metro, Migrations, Mitra, Montage, Nurture, Oriana, Parade, Pathways, PCT, Permiso, Player, Portal, Power Pincher, Progeny, Protégé, R2, Rally, Relevant, Reply, Rizzi Arc, Sensor, Series 9000, Siento, Sieste, Sine, Softcare, Springboard, Steelcase, Steelcase Design Partnership, Stella, Stow Davis, Swathmore, Sylvi, TeamWork, Technique, Texpress, Think, Thunder, Topo, Train, turnstone, Underline, Unison, Vecta, Viridian, Walden, Wernld, and X-Stack.
- The following registered trademarks are under license from AWI Licensing Company, Dover, DE: SoundScapes, DuraBrite, BioBlock, and Armstrong.
- The following registered trademarks are under license from Byrne Electrical, Rockford, MI: Interport, Mini-Port, Axil Z, and Ellora.
- The following is a registered trademark of DuPont, Wilmington, DE: Corian.
- The following is a registered trademark of Genlyte Thomas Company, Louisville, KY: Lightolier.
- The following is a registered trademark of Hilti Corporation, FL-9494 Schaan, Principality of Liechtenstein: Hilti.
- The following is a registered trademark of Leviton Manufacturing Company, Little Neck, NY: Decora.
- The following is a registered trademark of Mechanical Plastics Corp, Elmsford, NY: Toggler.
- The following is a registered trademark of Microsoft Corporation, Redmond, WA: Microsoft.
- The following is a registered trademark of Panduit Corporation, Lockport, IL: Panduit.
- The following is a registered trademark of Trav (Press), Cuneo, Italy: Assisa.
- The following is a registered trademark of Virtual Ink, Boston, MA: mimioActive.
- The following registered trademarks are under license from Wilkhahn Furniture Products: Avera, Senzo, Versal, and Wilkhahn FS.

- The following is a registered trademark of Wilsonart International, Temple, TX: Chemsurf.
- The following is a registered trademark of Wiremold, West Hartford, CT: Wiremold.
- The following is a registered trademark of EMU Group S.P.A., Perugia, Italy: Emu.
- The following is a registered trademark of Security People, Inc.: Digilock.
- The following are trademarks for products of Steelcase Inc. or one of its related corporate entities: Access, Active/Passive Shelf, Ainsley, Akira, Alcove, Alerion, Alight, Amaris, American Elect, American Tradition, ap40, Arbor, Arriva, Asana, Ascot, Aspekt, Astor, Await, Bassline, B-Free, Bira, Bivi, Bixby, Bottomline, Brody, Brook, Buoy, Burton, c:scape, Calla, Calm, Camber, Campfire, Capa, Cappuccino, Cesar, Chester, Chord, Circa, Clarendon, Classic Rectangular, Clipper, cobì, Collaboration, Community, Company, Convey, Cortex, Coupe, Crea, Crew, Cura, Cypress, Davenport, Dearborn, Deck, Déjà, Denizen, Denska, Derby, Divisio, Donovan, Dune, Duo, Echo, Edge, Elsna, Empath, Empress, Enea, ēno, EnSync, Enviro, Escapade, Exchange, Exponents, Field, Flat Top, FlexFrame, Flip Top, Flute, Folio, FrameOne, FreeFlow, Frontier, Galliei, Gesture, Ginger, Ginkgo, Go Wall, Grip, Groove, Hatchback, Hawthorne, Hitch, Host Collection, Hosu, Huddleboard, i2i, Impact, Indy, InfoLink, IOS, I-Solve, Jack, Jarrah, Jetty, Juice, Kami, Kast, Kathryn, Lagunitas, Lark, L'Attitude, LearnLab, Leela, LessThanFive, Lincoln, Linden, LiveSeat, Loria, Lyric, Malibu, Malibu Too, Mansfield, Marathon, Martini, Mason, Masque, Migration, Millbrae, Mineral, Mingle, Mystic, Mystic Metal, Mystic Wood, Montara650, Montreal, Move, Nadia, Neighbor, nesso, Nickel, Nikko, Nod, Node, Norfolk, Ology, Ontrak, Oom, Opus, Orchid, Outlook Collection, Ovation, Paloma, Paperflo, Parliament, Pasio, Passerelle, Patriarch, Payback, Peek, Pile File, Pisa, Pool, Potrero415, PUCK, QiVi, Quba, Rave, Reed, Regard, Relay, Reunion, Ripple, Riser, Roam, Rocco, Rocky, RoomWizard, Runner, Satellite, Sawyer, ScapeSeries, Senti, Sentinel, Senza, Sequoia, Session, ShareLink, Shield, Shortcut, Sidewalk, SILQ, Skylar, Slumber, Smoke, Snug, Soft Leaf, Sonata, Sorrel, SOTO, Southside, Stationkits, Steelcase Series, Stiletto, Surprise!, Surround, Switch, Symphony, Sync, TagWizard, Tava, TeamStudio, TeamTheater, Tenaro, Terrazzo, Theorem, Thread, Topaz, Touchdown, Tour, Tower Too, Trees, Trillium, Trolley, tX2, U-Free, Umami, Underscore, Uno, V.I.A., Verb, Verge, Verlay, Victor2, Visalia, Waldorf, Woodruff, Workspring, and X-tenz.
- The following is a trademark of Microsoft Corporation, Redmond, WA: Windows.
- The following is a trademark of Rodman Industries, Inc., Oconomowoc, WI: ResinCore1.
- The following is a trademark of Ultrafabrics, LLC, Elmsford, NY: Ultraleather.

- The following trademarks are under license from Wilkhahn Furniture products: Cana, Linus, Logon, Picto, Range, Stitz, Thema, Timetable, and Tubis.
 - The following trademark is used under license from Cradle to Cradle Products Innovation Institute, Oakland, CA: Cradle to Cradle Certified.
 - The following trademarks are under license from Walter Knoll: Andoo, Bob, Lazlo, Lox, Ribbon, and Together.
 - The following trademarks are under license from PP Möbler: Bar and Flag Halyard.
 - The following trademarks are under license from Viccarbe: Davos, Holy Day, Last Minute, RS, Sistema, and Wrapp.
 - The following trademarks are under license from Carl Hansen: Elbow, Paddle, Shell, Wing, and Wishbone.
 - The following trademarks are under license from Cambridge Sound Management, LLC, Cambridge, MA: QtPro Soundmasking, Qt Quiet Technology, and Sonet Qt.
 - The following is a trademark of Electri-Cable Assemblies, Shelton, CT: Interact.
 - The following is a trademark of Clestra Hauserman: IRYS.
 - The following is a trademark of Wiesner-Hager Möbel GmbH: Nooi.
 - The following are trademarks of PolyVision: a³, e³, Flow, Motif, PolyVision, Sans, and Serif.
 - The following is a trademark of Bostock Company, Inc: SnapCab.
 - The following is a trademark of Williams-Sonoma, Inc: West Elm.
 - The following is a trademark of Elena Marquina Testor: nanimarquina.
 - The following is a trademark of Forbo International SA: Forbo.
- Trademarks used here in are the property of Steelcase, Inc. or of their respective owners.*