

Steelcase

CF Series Flat Panel Monitor Arm

CFSHA and CFSDA

User Guide

CF Series Flat Panel Monitor Arm

CFSHA and CFSDA

For single or dual monitors—displayed side by side or stacked—the CF Series Flat Panel Monitor Arm secures screens in the optimal position to meet a wide range of employees' needs. Easily bring monitors closer for detailed work or move them farther away with the touch of a hand.

CFSHA supports displays up to 27" and up to 25 lbs.

CFSDA supports displays up to 24" and up to 25 lbs per monitor. Use of 24" monitors will reduce available focal depth adjustment.

It is not advisable to install dual arms on 24" or less deep worksurfaces due to lack of focal depth adjustment.

CFSHA Single-Arm Pole Mount

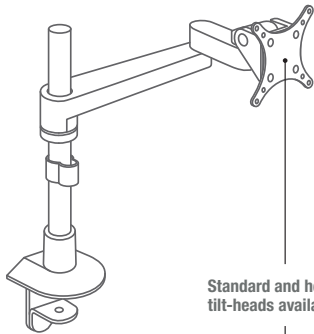

Standard and heavy-duty
tilt-heads available

CFSDA Double-Arm Pole Mount

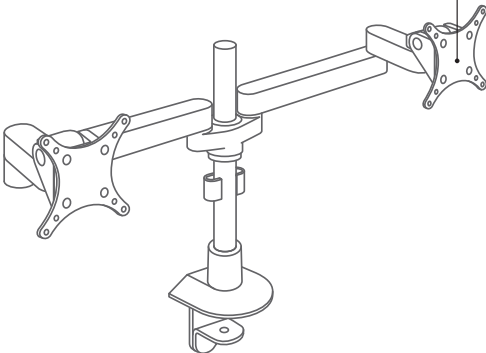

CF Series Flat Panel Monitor Arm Controls

CFSHA and CFSDA

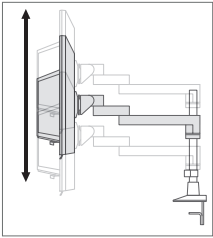

HEIGHT ADJUSTMENT

CF Single Pole and Double Pole Series arms can be adjusted vertically 10" for the CF14 or 24" for the CF28. CF28 supports displays up to 15 lbs per monitor.

To reposition the arm on the post:

- Slide the arm upward
- Move the outer retention ring up
- Place the inner retention ring into the appropriate height location hole
- Slide the outer retention ring back over the inner retention ring and slide the arm downward into position

(See assembly drawings: steelcase.com/content/uploads/2016/01/CF-Series-Pole-Mount-Flat-Panel-Monitor-Arm-Assembly-Directions.pdf)

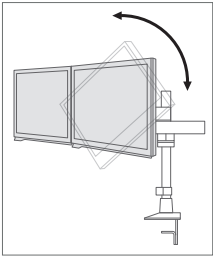

VIEWING ANGLE ADJUSTMENT

The viewing angle of the monitor can easily be adjusted by simply rotating the monitor to suit your viewing needs. The spring-assisted tilt-head is easy to maneuver and allows the monitor to be positioned for either portrait or landscape orientation.

The arm has a forward and backward tilt of 200°.

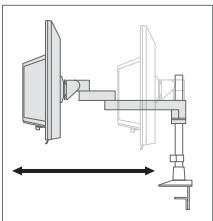

FOCAL LENGTH ADJUSTMENT

For user comfort, easily bring monitors closer for detailed work or move them farther away with the touch of a hand, without altering the height or angle of the screens. Functional focal length is 14". For dual displays, functional focal length adjustment is dependent on monitor size.

Basics of Monitor Arm Positioning

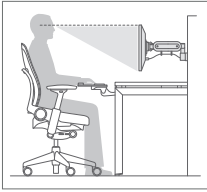

HEIGHT

Top of the display should be positioned at or slightly below eye level.

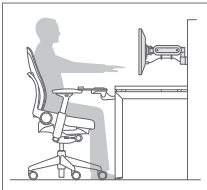

DISTANCE

Display should be 20" to 30" from the eyes or approximately an arm's length away.

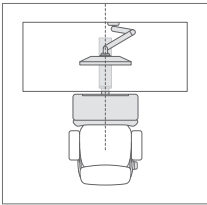

ALIGNMENT

Proper alignment is the key to preventing strain. Computer display, keyboard and mouse should be centered to allow user to see the display without looking downward or to either side. Mouse should be accessible without twisting or reaching. Reference documents should never be flat on the desk and should be at the same height as or aligned with the display or above the keyboard and below the display.

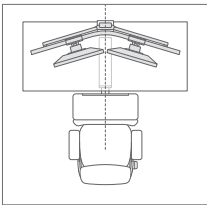

DUAL DISPLAY ALIGNMENT

If using two displays, position the display used more often closer. If equally used, center displays directly in front and angle them in a slight inward "V" shape.

Steelcase®

Visit steelcase.com

4/16 © 2016 All rights reserved. All specifications subject to change without notice. Printed in U.S.A.