

---

# turnstone



## Specification Guide

### Availability

**Electronic price list updated** with release 182.B (U.S.) and 147.B (Canada), dated June 15, 2015.

Spec News is available on [village.steelcase.com](http://village.steelcase.com). Search AdStock and download the current release's Spec News.

View or download Steelcase Specification Guides at <http://www.steelcase.com/en/resources/design/spec-guides/pages/specguides.aspx>.

Transitional products in this specification guide are **maintained for existing customers only** and are likely to be phased out over time. These products are indicated with a . Products that are scheduled to be culled are indicated with an , followed by the last order entry date.

<b>Terms and Conditions</b>	<b>2</b>
<b>Additional Resources</b>	<b>3</b>

<b>Bivi</b>	<b>5</b>
<b>Tour Workspace</b>	<b>65</b>
<b>Campfire</b>	<b>129</b>
<b>Seating</b>	<b>161</b>
<b>Tables</b>	<b>251</b>
<b>Details Ergonomic Worktools</b>	<b>265</b>

<b>Surface Materials</b>	<b>305</b>
<b>Resources</b>	<b>327</b>

**This specification guide contains multiple Steelcase and turnstone product lines** which are designed into one specification guide for your convenience. Note that each product may be subject to different pricing terms and conditions.

► For a list of all trademarks, refer to the last page of this specification guide.  
© 2015 Steelcase Inc.



### For Canadian Pricing

Canadian factor can be found at [steelcase.com/CADpricing](http://steelcase.com/CADpricing).

Calculate in the following order to avoid rounding errors:

- Multiply the base price and each option by the Canadian factor.
- Round each to the nearest dollar.
- Add base and options for total list price.

# Terms and Conditions

## Terms

**Payment terms** for turnstone are the same as current Steelcase terms, providing you the opportunity for additional cash discounts for prompt payments.

**Payment for turnstone brand products** can be remitted with payments for Steelcase brand products. You can even use the same check!

**Past due amounts** are subject to 1.5% service charge per month on the unpaid balance.

## Returns

If product you have received must be returned because of turnstone error or quality issues, your SFT representative can help. All returns must be authorized; products that are not authorized for return will not be accepted.

## Claims

**For freight claim information**, go to [village.steelcase.com](http://village.steelcase.com), then Order Management, then Service and Warranty, then Freight Claims.

## Order Changes

**All orders** delivered within standard lead times are considered final and cannot be changed.

**Any charges** for changes or cancellations are the responsibility of the dealer.

**Special order products** cannot be changed or canceled.

## Freight Costs

**All shipments to points in the 48 contiguous states** will be shipped factory freight prepaid (FOB).

**All shipments outside** the 48 contiguous states will be shipped FOB and allowed to point of embarkation. All charges beyond the point of embarkation are collect.

**Call 1.800.TURNSTONE, option #2** for quotes on Expedited shipments, UPS delivery, or deliveries outside the continental U.S.

**turnstone reserves the right** to select the most appropriate mode of shipment from the manufacturing point and point of embarkation.

**Special shipping methods, handling, or setup** will be subject to an additional charge.

## Delivery/Lead Times

**Most products** will be shipped in 5-7 business days after receipt of a clean order. Products are typically delivered 10-12 business days.

**Leadtimes** are subject to available capacity. High-Pressure Laminate on the Campfire Slim Table and Campfire Skate Table will be shipped in 20 business days after receipt of a clean order. Products are typically delivered in 25 business days.

**For up-to-date lead times**, consult the scheduling/delivery schedules bulletin board on [village.steelcase.com](http://village.steelcase.com), then Order Management.

**Please call 1.800.TURNSTONE** and ask for your Solutions Fulfillment Team Representative for orders in excess of 50 units.

## Surface Materials

**Only fabric price groups 1-3** will ship in 5-7 business days. Standard turnstone laminates and paints will ship in 5-7 business days. Established and transitional finishes and fabric price groups 4 and higher will deliver in 15 business days or more. COM, PerfectMatch, Open Line laminate and Specials orders are scheduled based on material availability. Please see the Surface Materials chapter for exceptions and additional details.

## Assembly

**Due to construction, design of the product, or delivery conditions**, it is necessary to ship most turnstone products cartoned. turnstone products that are shipped unassembled are shipped RTA (ready to assemble) and are easy to assemble.

**turnstone products** are supported with an array of informational materials, tools, and software to help you plan and install efficiently.

**Product brochures and planning tools** can be ordered through your Steelcase area office by calling 1.800.784.0358 or through the AdStock web site at [village.steelcase.com](http://village.steelcase.com).

## Product Brochures

### Seating Product Overview Sheets

Jenny  
Form Number 09-0000373

Lincoln  
Form Number 08-0000220

align  
Form Number 08-0000216

Scoop  
Form Number 08-0000241

### Desking Product Overview Sheets

Tour  
Form Number 09-0000862

Campfire  
Form Number 10-0002592

## Surface Materials

### turnstone Surface Materials Swatches

Individual swatches, larger memo samples, and family group swatch cards are available by contacting Ad Stock at 1.800.784.0358 or by ordering electronically at [village.steelcase.com](http://village.steelcase.com).

## Printed Materials

### Surface Materials Reference Manual

This publication provides:

- An explanation of the surface materials program
- “Available on” matrices
- Vertical surface fabric and seating upholstery selection listing
- Technical data for surface materials
- Surface material care and cleaning instructions

## Computer Tools

### On the Web [www.turnstonefurniture.com](http://www.turnstonefurniture.com)

Visit turnstone’s Web site for a complete product listing, photos, case studies, where to find a turnstone dealer, and much more.

### Bird’s Nest

turnstone’s dealer Web site includes pricing and terms, user guides, case studies, spec guides, lead times, printable brochures, photos, and more. Dealers access Bird’s Nest through [www.turnstonefurniture.com](http://www.turnstonefurniture.com), using their [village.steelcase.com](http://village.steelcase.com) password.

Furniture symbol graphic data are available for download on [www.steelcase.com](http://www.steelcase.com).

## Electronic Catalog

Accurate sales quotations and purchase orders for turnstone products are created with specification software that uses turnstone Electronic Catalog data. Use the data to specify and price style numbers and options for every turnstone product. The data is updated bimonthly by Steelcase and provided to software programs like the Hedberg Business System, 20-20 CAP Studio.

### Furniture Symbol Graphic Data

Steelcase creates 2D and 3D furniture symbols (with attributes) for planning and initially specifying Steelcase products. This data is incorporated into several add-on software packages that work in either a Microstation or an AutoCAD drafting environment.

For more information about these and other software tools to help you plan effective work environments, please email [fsl@steelcase.com](mailto:fsl@steelcase.com)



### Digital Publications

If your device has a bar code reader App, scan this QR code for a direct link to the online digital publications. Utilizing this QR code allows you to search across multiple specification guides, share across social media, or print out pages. You can also access these digital publications at [www.steelcase.com](http://www.steelcase.com) or [village.steelcase.com](http://village.steelcase.com).

## Support

### Steelcase Capabilities

Steelcase products are distributed, installed, and serviced through a network of more than 600 dealers worldwide. Steelcase is also represented with offices and corporate showrooms in 26 U.S. cities, 4 Canadian cities, and in France, Germany, Great Britain, and Japan. Every Steelcase product meets our exceptionally high standards of quality and durability and comes with the Steelcase assurance of excellence in service.

**For assistance**, please call your local dealer, the Steelcase Solutions Resource Team, or the Steelcase Solutions Fulfillment Team at 1.800.TURNSTONE (1.800.887.6786).

Call the Steelcase Solutions Fulfillment Team if you have submitted an order to Steelcase and you need to speak to your Solutions Fulfillment Team Representative about the order. Also call if you have any post-shipment quality or warranty concerns or service parts questions.

Outside the U.S.A., Canada, Mexico, Puerto Rico, and the U.S. Virgin Islands, call 1.616.247.2500.





**Statement of Line** **6**



**Product Details**

Application Guidelines	<b>12</b>
Building with Bivi	<b>13</b>
Tables	<b>14</b>
Grain Direction	<b>16</b>
Cable Trough	<b>18</b>
Electrical Components	<b>20</b>
Storage	<b>26</b>
Arches and Accessories	<b>28</b>
Rumble Seat and Hoodie	<b>32</b>
Components and Accessories	<b>34</b>



**Specifying**

Tables	<b>37</b>
Electrical Components	<b>46</b>
Storage	<b>50</b>
Arch and Arch Accessories	<b>51</b>
Rumble Seat and Hoodie	<b>55</b>
Components and Accessories	<b>57</b>
Eyesite	<b>62</b>



**Surface Materials** **64**

# Statement of Line

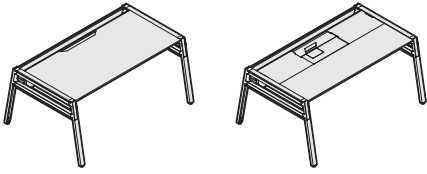

Understanding  
 ▶ Pages 14-15  
 Specifying  
 ▶ Pages 37-39

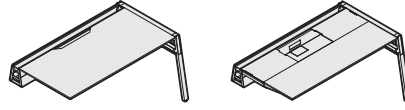

Understanding  
 ▶ Pages 14-15  
 Specifying  
 ▶ Pages 37-39

## Table for One

	D	W
Table	42 <sup>1</sup> / <sub>4</sub> "	50" or 62"
Table with Back Pocket	42 <sup>1</sup> / <sub>4</sub> "	62"

## Table Plus One

	D	W
Table Plus One	42 <sup>1</sup> / <sub>4</sub> "	48" or 60"
Table Plus One with Back Pocket	42 <sup>1</sup> / <sub>4</sub> "	60"

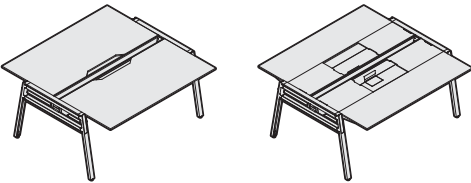

Understanding  
 ▶ Pages 14-15  
 Specifying  
 ▶ Pages 42-43

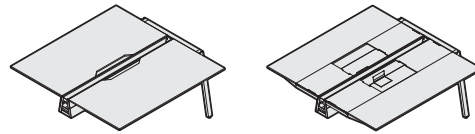

Understanding  
 ▶ Pages 14-15  
 Specifying  
 ▶ Pages 42-43

## Table for Two

	D	W
Table for Two	60"	50" or 62"
Table for Two with Back Pockets	60"	62"

## Table Plus Two

	D	W
Table Plus Two	60"	48" or 60"
Table Plus Two with Back Pockets	60"	60"

## Electrical Components

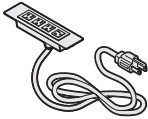

### Plug and Play Power Kit - Package of One

Understanding  
▶ Pages 20-24  
Specifying  
▶ Page 46

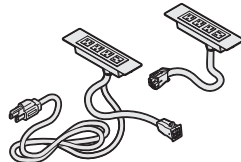

### Plug and Play Power Kit - Package of Two

Understanding  
▶ Pages 20-24  
Specifying  
▶ Page 46

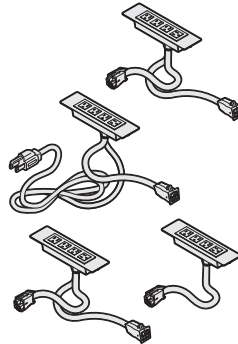

### Plug and Play Power Kit - Package of Four

Understanding  
▶ Pages 20-24  
Specifying  
▶ Page 46

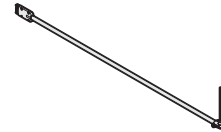

### Hardwired Base Power-In

Understanding  
▶ Pages 20-24  
Specifying  
▶ Page 47

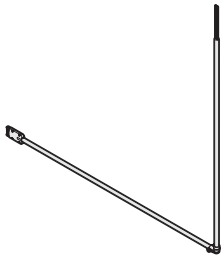

### Hardwired Base Power-In, San Francisco

Understanding  
▶ Pages 20-24  
Specifying  
▶ Page 47

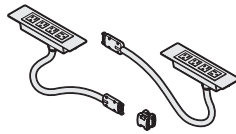

### Hardwired Powerways

Understanding  
▶ Pages 20-24  
Specifying  
▶ Page 48

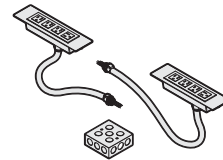

### Chicago Accessory Powerway

Understanding  
▶ Pages 20-24  
Specifying  
▶ Page 48

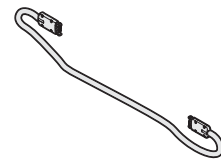

### Table-to-Table Power Connector

Understanding  
▶ Pages 20-24  
Specifying  
▶ Page 49

Statement of Line, continued

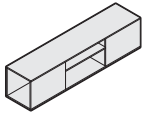

Understanding  
 ▶ Pages 26-27  
 Specifying  
 ▶ Page 50

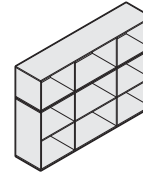
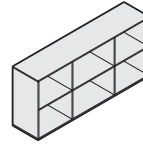
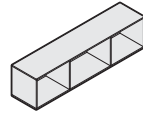

Understanding  
 ▶ Pages 26-27  
 Specifying  
 ▶ Page 50

**Trunk**

	16"W
14"D	●

**Depot**

	15"H	28 1/2"H	42"H
13 7/8"D	●	●	●

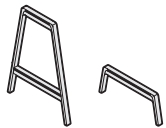

Understanding  
 ▶ Page 28  
 Specifying  
 ▶ Page 51

**Arch**

	D	W	H
Tall Arch	2"	32 3/8"	44"
Short Arch	2"	32 3/8"	13"

**Arch Accessories**

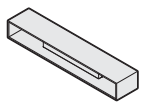

**Side Storage**  
 Understanding  
 ▶ Page 28  
 Specifying  
 ▶ Page 52



**Monitor Mount**  
 Understanding  
 ▶ Page 28  
 Specifying  
 ▶ Page 52



**Bike Hook**  
 Understanding  
 ▶ Page 28  
 Specifying  
 ▶ Page 53



**Markerboards**  
 Understanding  
 ▶ Page 28  
 Specifying  
 ▶ Page 53



**Canopy**  
 Understanding  
 ▶ Page 28  
 Specifying  
 ▶ Page 54



**Board Rack**  
 Understanding  
 ▶ Page 28  
 Specifying  
 ▶ Page 54



**Holder**  
 Understanding  
 ▶ Page 28  
 Specifying  
 ▶ Page 54



**Planter**  
 Understanding  
 ▶ Page 28  
 Specifying  
 ▶ Page 54

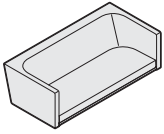

Understanding  
 ▶ Pages 32–33  
 Specifying  
 ▶ Page 55

**Rumble Seat (with or without exposed bracket)**

D	W	H
28"	58"	16"



Understanding  
 ▶ Pages 32–33  
 Specifying  
 ▶ Page 55

**Rumble Seat Supports**

	D	W	H
Freestanding Legs	28"	58"	12"
Table Frame Attachment Brackets	5 1/2"	17"	16 5/8"

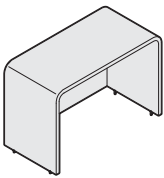

Understanding  
 ▶ Pages 32–33  
 Specifying  
 ▶ Page 56

**Hoodie**

D	W	H
28"	58"	38 1/8"

**Components and Accessories**



**Half Round Table Top**

Understanding  
 ▶ Page 34  
 Specifying  
 ▶ Page 57

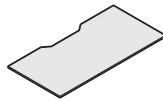

**Table Top**

Understanding  
 ▶ Page 34  
 Specifying  
 ▶ Page 57

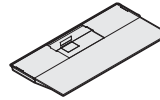

**Table Top with Back Pocket**

Understanding  
 ▶ Page 34  
 Specifying  
 ▶ Page 57



**Pocket Cover**

Understanding  
 ▶ Page 34  
 Specifying  
 ▶ Page 58

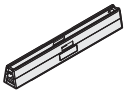

**Cable Trough**

Understanding  
 ▶ Page 18  
 Specifying  
 ▶ Page 58



**Leg**

Understanding  
 ▶ Page 34  
 Specifying  
 ▶ Page 58



**Top Shelf**

Understanding  
 ▶ Page 34  
 Specifying  
 ▶ Page 59



**Bottom Shelf**

Understanding  
 ▶ Page 34  
 Specifying  
 ▶ Page 59



**Hook**

Understanding  
 ▶ Page 34  
 Specifying  
 ▶ Page 59

---

## Components and Accessories, continued



**Screen**  
Understanding  
▶ Page 28  
Specifying  
▶ Page 60



**Organizer**  
Understanding  
▶ Page 28  
Specifying  
▶ Page 60



**Trough End Cover**  
Specifying  
▶ Page 61



**Trough Floor Cover**  
Specifying  
▶ Page 61



**Leg Cover**  
Specifying  
▶ Page 61

---

## Eyesite



**Eyesite Single Display Support**  
Specifying  
▶ Page 62

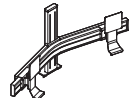

**Eyesite Dual Display Support**  
Specifying  
▶ Page 62



**Eyesite Single Laptop Support**  
Specifying  
▶ Page 62

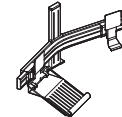

**Eyesite Dual Laptop Support**  
Specifying  
▶ Page 63



**Bivi Bracket**  
Specifying  
▶ Page 63



# Application Guidelines

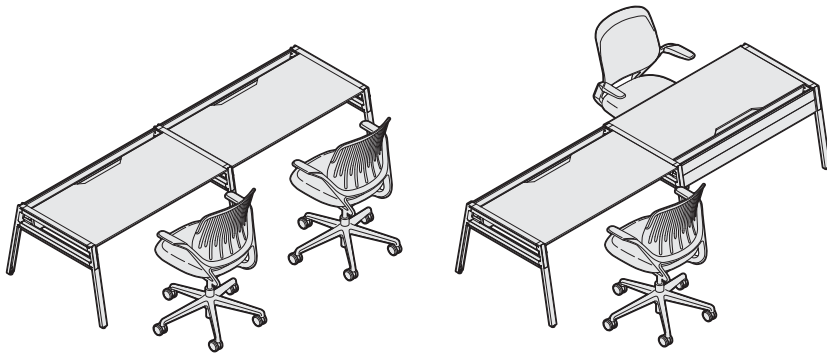

**Bivi Table for One** and a Table Plus One can be attached with users sitting next to or across from each other.

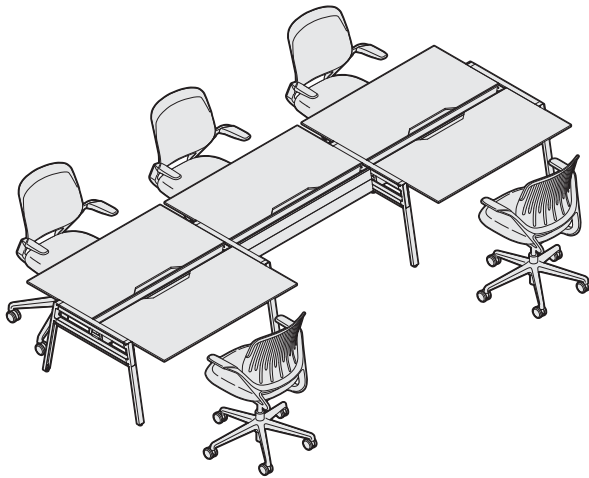

**When an architectural obstruction** such as a column occurs, one table top can be left off.

Bivi Table for Two and Half-Round Table Tops create a conference table for six.

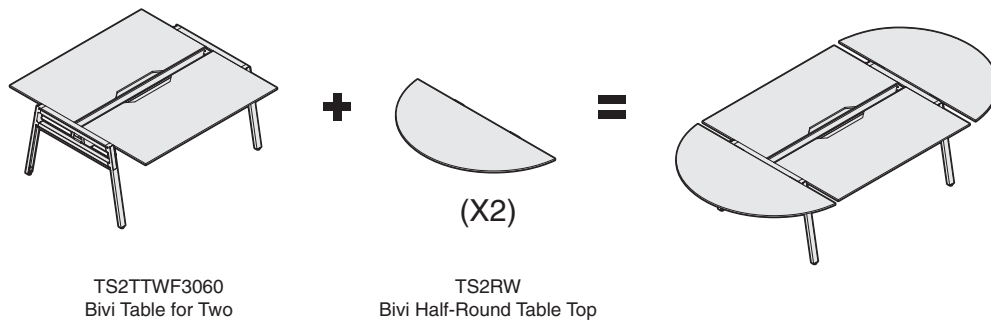

Bivi Table for One and Table Plus One connect to make a team space. If reconfiguration is desired, one option would be to order an additional Bivi Leg and separate into individual tables.

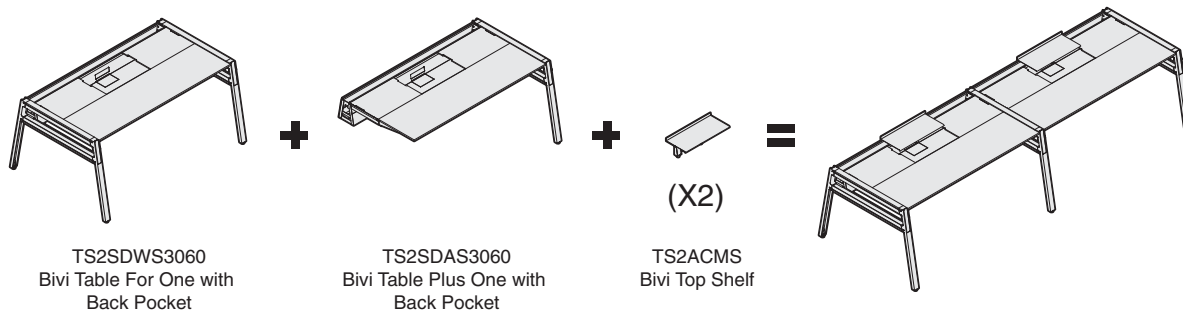

Bivi Table for Two and Table Plus Two come with either two Table Tops or two Table Tops with Back Pockets. In order to create a combination shown below, use a Bivi Table Plus One and an extra Table Top.

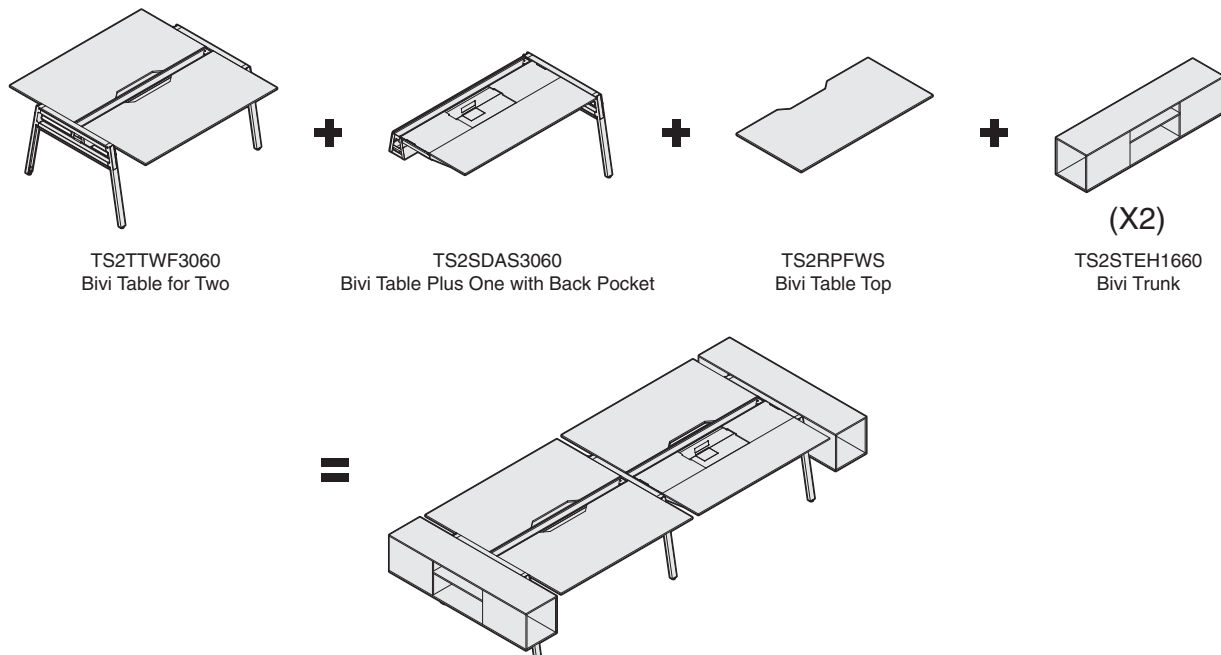

# Tables

## Table for One, Table Plus One, Table for Two, and Table Plus Two Overview

### Bivi Table for One

comes standard with a cable trough, two legs, and a full table top or a table top with a back pocket. Bivi Table Plus One comes standard with a cable trough, one leg and a full table top or a table top with a back pocket.

► Specifying, page 37

### Bivi Table for Two

comes standard with a cable trough, two legs, and two full table tops or table tops with a back pocket. Bivi Table Plus Two comes standard with a cable trough, one leg, and two full table tops or table tops with a back pocket.

► Specifying, page 41

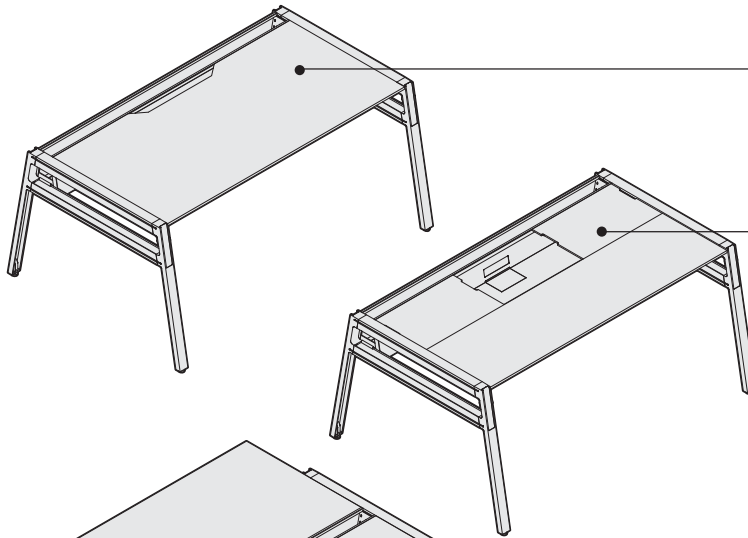

**Table top** is 1/2" thick with edge to laminate color.

**Two pocket covers** match the laminate table top and conceal two-thirds of the back pocket allowing the pocket covers to slide side-to-side to access stored items.

**Width of worksurface** is available in either 48"W or 60"W. Width of worksurface with back pocket is only available in 60"W.

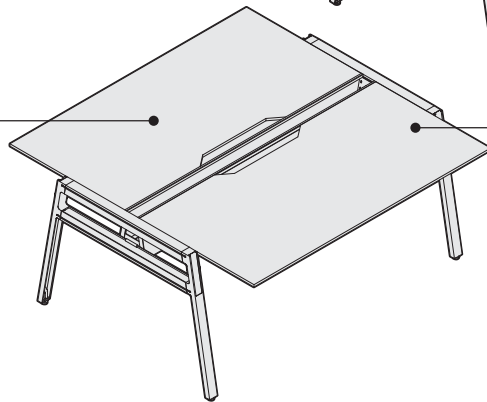

**Height of worksurface to floor** is 28 1/2".

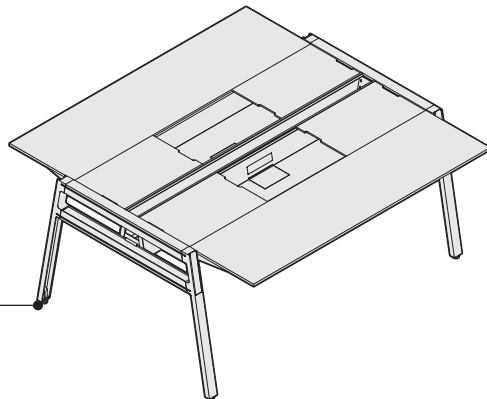

**Leveling glides** have 1 1/2" adjustability range to install tables on uneven floors.

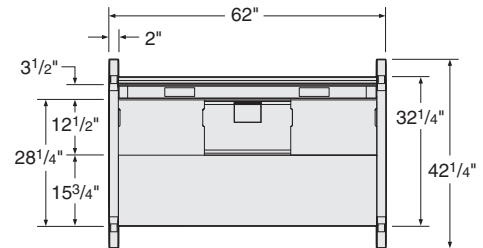

Table for One

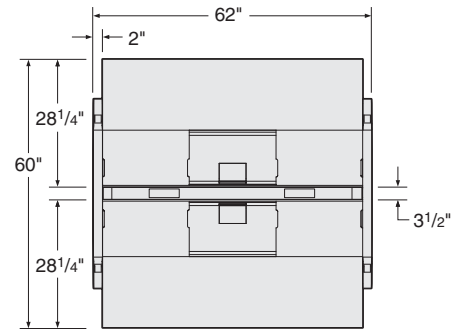

Table for Two

*Tip: Table for One and Table for Two without back pockets are available in 50"W.*

### Actual Dimensions

	Table for One	Table Plus One	Table for Two	Table Plus Two
Depth	42 1/4"	42 1/4"	60"	60"
Width	50", 62"	48", 60"	50", 62"	48", 60"
Height	28 1/2"	28 1/2"	28 1/2"	28 1/2"
Worksurface Thickness	1/2"	1/2"	1/2"	1/2"

### Product Details

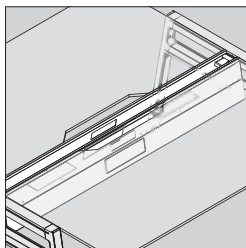

**Cable troughs** are used to hold power, wires, and blocks. Each cable trough has four areas for power. Two areas are in the center of the trough and one on each side. The power locations on the side of the cable trough have knockouts that can be removed if power in these locations is desired.

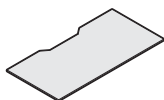

**Bivi table top** has a full depth top. The table top is available in two different widths, 48"W or 60"W. The Bivi table top can be ordered as a separate component.

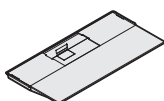

**Bivi table top with back pocket** has a half depth top and a back pocket area for storage. Table top with back pocket comes with two pocket covers. The Bivi table top with back pocket can be ordered as a separate component.

### Connections

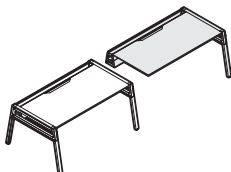
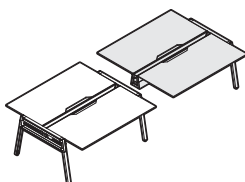

**Plus tables** come with one leg and adjustable glides with a 1 1/2" range. Tables can be connected to an existing table in order to create a benching application. Two tables share one leg.

### Electrical

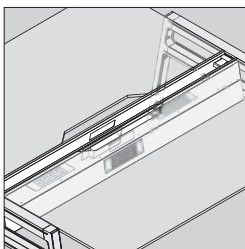

**Access for power** is located in four areas of the cable trough. Two in the center of the trough and one on each side of the trough.

**Accessory powerways**, TS2P260, can have a maximum of six powerways connected per one hardwired base power-in, TS2PBT2 or TS2PBT2SF for a maximum of 48 plugs.

### Weight Capacities

**Table for One:** 200 pounds.

**Table for One with back pocket, split table top:** 200 pounds and back pocket: 40 pounds.

**Table for Two:** 400 pounds.

### Surface Materials

**Table tops**

- Laminate

**Pocket covers**

- Laminate

**Legs, cable trough, and back pocket**

- Paint

# Grain Direction

The appearance of laminate may change slightly depending on the angle from which it is viewed. This natural phenomenon is called polarization, and it can be seen on natural veneer, and to a lesser extent on composite veneer. Polarization is often noticed on worksurfaces installed at a 90° angle with each other. Please refer to the following illustration for an understanding of grain direction on your installation.

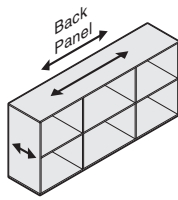

Depot, Big Depot, and Bigger Depot

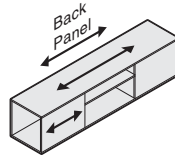

Trunk

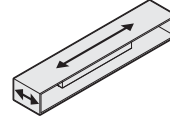

Side Storage

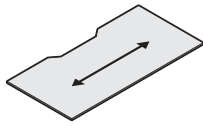
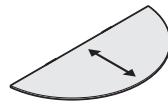

Table Tops



Half Round Table Top



# Cable Trough

**Data ports** can also be set in the bottom half or the top half of the trough and accessed through the various cable routing openings.

**The top half of the cable trough** holds power strips and manages personal cords such as a phone charger, iPod, or laptop cord.

**The openings on the side of the cable trough and the end of each trough** are for routing cables in and out.

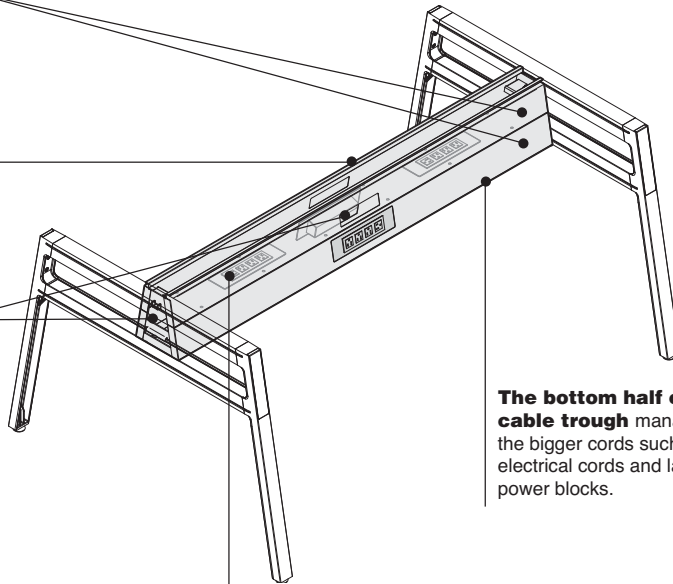

**The bottom half of the cable trough** manages the bigger cords such as electrical cords and laptop power blocks.

**The cable trough** has two openings for power in the center of the trough. There are trough cover plates (TS2CTFC, package of two) available if you do not choose to use both or either of these locations.

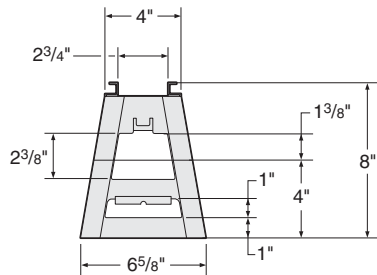

## Product Details

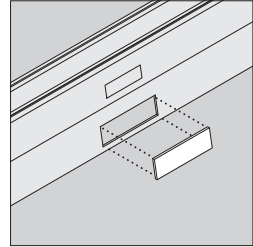

**A perforated metal rectangle** located at both sides of the cable trough can be knocked out to gain access to power if power is installed at the side of the trough. Once removed, the opening is permanent. There are no fillers available for this location.

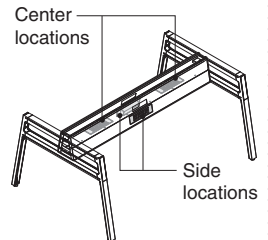

**If both locations in the center and both locations in the side of the cable trough** are used for power, there is a total of four power strips available in one trough. A package of four (TS2PS4PK), ordered separately, would allow a total of 16 plugs.

*Tip: 48"W Bivi tables do not allow for four-pack hardwire power options.*

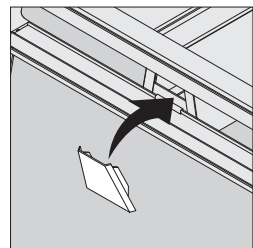

**A trough end cover (TS2CTEC, package of two)** is available if closed end is preferred.

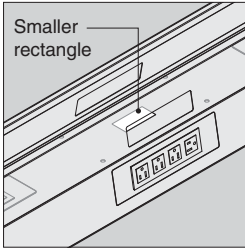

**The smaller perforated metal rectangle** is a standard size that fits most data faceplates. Once removed, the opening is permanent. There are no fillers for this location.

**Surface Materials**

- Paint

# Electrical Components

**Bivi electrical components** are simple and easy to install. Power kits and hardwired powerways can be installed in the cable trough, which provides easy access.

▶ Specifying, page 46

**Bivi power kits and hardwired powerways** have spill-proof technology to prevent electrical shorts.

**Knockouts** are located on each side of the cable trough. Knockouts can be removed and power strips installed for access to power from the side of the trough.

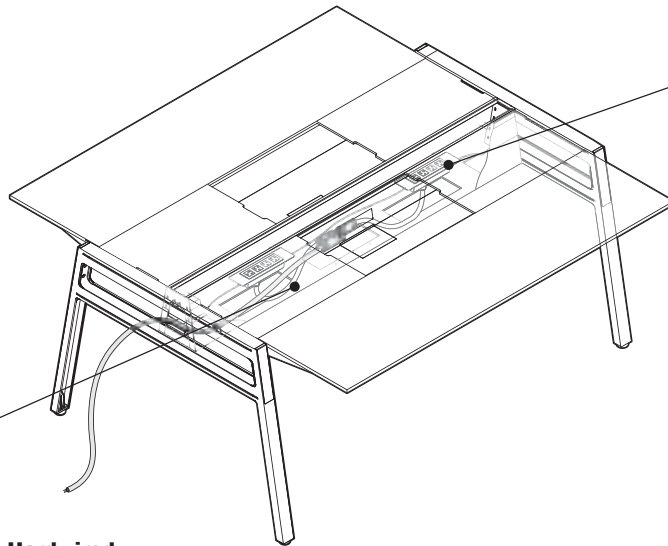

**Hardwired**

**Hardwired powerways**, TS2P260 and TS2P2CHI, have two sections with four receptacles each for a total of eight receptacles.

**48"W Bivi tables** only allow for one modular hard-wire power, TS2P260, or for one Chicago hardwire powerway. Each powerway comes with two strips for a total of eight plugs.

**Steelcase products** are designed and tested for code and standard compliance when installed and used as an integrated product solution in accordance with Steelcase application guidelines and installation instructions. However, the building owner or designated agent is responsible for verifying that the installation is in compliance with local codes and regulations.

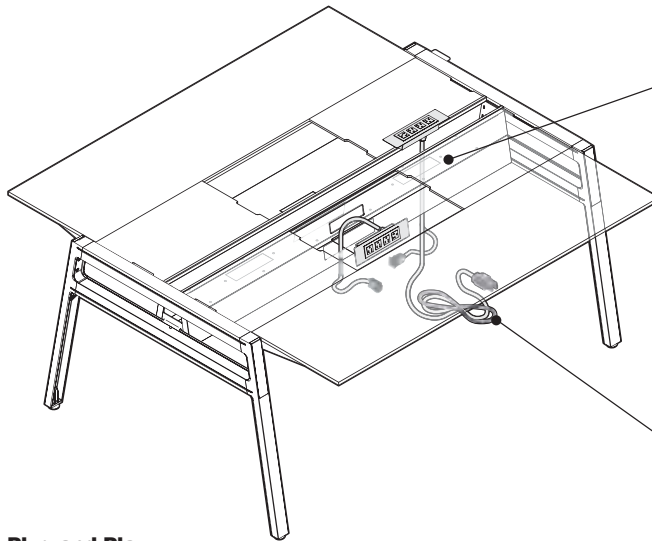

**Plug and Play**

**Plug and play power kit package of two**, TS2PS2PK, has two sections with four receptacles each for a total of eight receptacles.

**Plug and play power kit package of four**, TS2PS4PK, has four sections with four receptacles each for a total of 16 receptacles.

**48"W Bivi tables** allow for four-pack plug and play.

**Plug and play power kits** have a 15-amp 10' cord that plugs into a building receptacle.

**Product Details**

**Two-pack and four-pack power strips** do not connect together as this would cause a potential power failure and hazard. Power strips must plug into an individual power source.

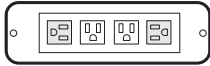

**Power strips** have the first and last receptacle rotated out to accommodate larger power units.

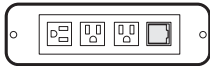

**Power strips** have four simplex plugs. The fourth position can have either one open data port or two USB ports optioned in place of the simplex plug.

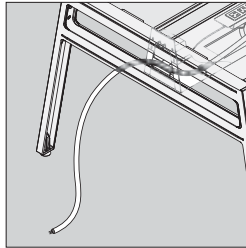
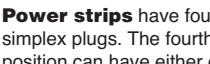
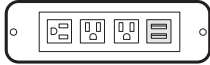

**Power Specifications**

- Single circuit power
- 12-amp system rating
- 15-amp power cord with 15-amp over-current protection
- UL recognized Powered Table System component per UL962

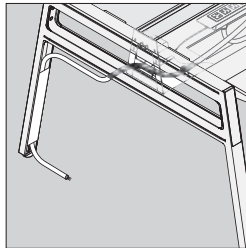

**Surface Materials**

- Power strips**
- Paint

**For the standard Bivi modular hardwire base power**, there is 22" of conduit with 6" of wire length once the power hits the floor for the electrician to work with and connect to the building power source. There is 9" of conduit if the leg cover is used to route the power down the Bivi leg.

**Bivi San Francisco hardwired modular power** can be used outside of San Francisco. If more conduit length is desired, it has 72" length of conduit from the point of coming straight out of the table and 59" if using the leg cover wire management solution.

**The San Francisco hardwired base power** can be used in other areas of the country where local codes allow liquid tight conduit if additional conduit length is desired. Check with local electrical inspectors.

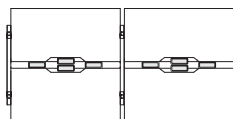

**Table-to-table connectors** are used when connecting power between two Bivi tables or when two hardwired powerways are used in one Bivi table.

**Bivi Plug and Play Understanding**

**Plug and play power** have 5' of conduit between receptacle strips, that gives room to share power between multiple tables in some applications. Plug and play power kits are color coded and connect into each other.

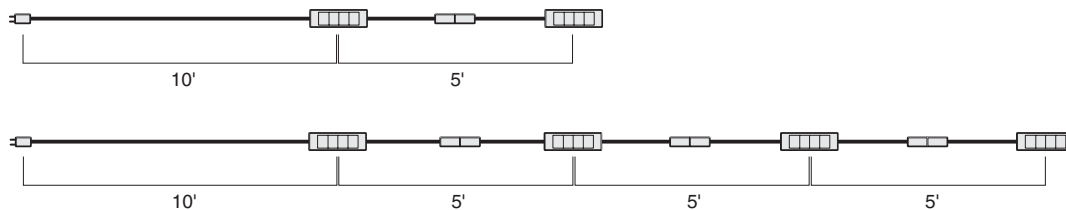

**2-Pack plug and play power kits** have maximum of one connection point. 4-pack plug and play power kits have maximum of three connection points. Chicago has a unique powerway, see specifying page 48. San Francisco has a unique hardwire base power-in, see specifying page 47.

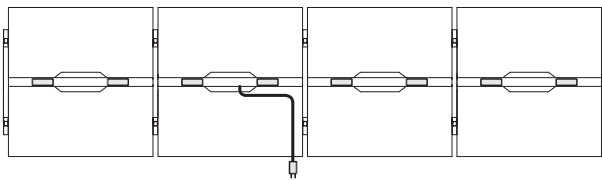

**Bivi tables** do not have maximum table limit. An unlimited amount of tables can be connected together. Plug and play power will need to be plugged into a building outlet in the middle of runs when multiple tables are connected and power is used.

**Openings** can be skipped to stretch out the power to more users. There is 5' of cord length between power strips which allows this.

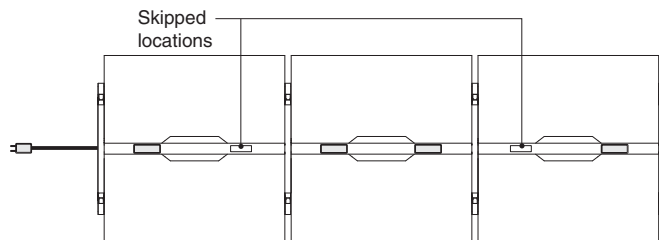

**Six Person Example**

Provides two (2) plugs per person at the table for two at each end and four (4) plugs per person at the table for two in the middle of the setting. Requires quantity of one (1) package of four (TS2PS4PK) and one (1) building outlet to power up table.

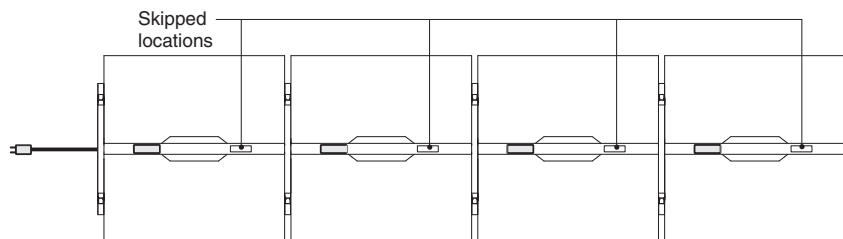

**Eight Person Example**

Provides two (2) plugs per person. Requires quantity of one (1) package of four (TS2PS4PK) and one (1) building outlet to power up table.

### Bivi Plug and Play Power Understanding

Modular hardwire powerways, TS2P260, have two power strips for a total of eight simplex receptacles (power plugs).

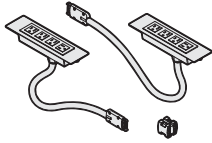

60" Bivi tables can fit a maximum of two (2) powerways per trough, one located at the top of the trough and one located on each side of the trough. Most often one (1) powerway is specified per trough, located at the top of the trough.

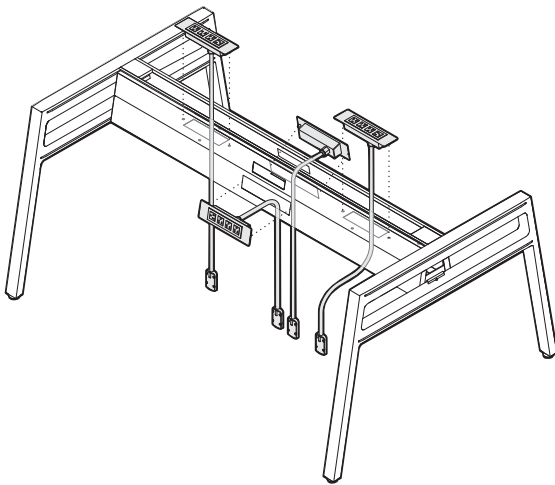

When additional Bivi Plus One or Plus Two tables are added a table-to-table connector will be required, TS2PT2T.

**Bivi Plug and Play Power Understanding, Continued**

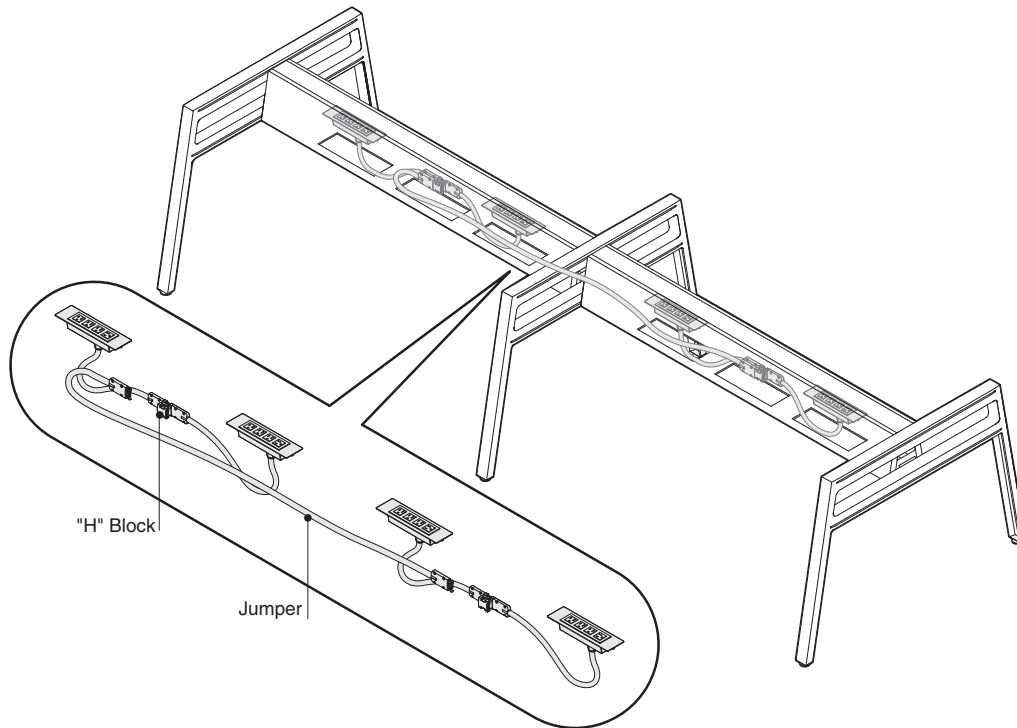

When specifying two (2) powerways to be assembled into one trough an additional table-to-table connector will be required, TS2PT2T.

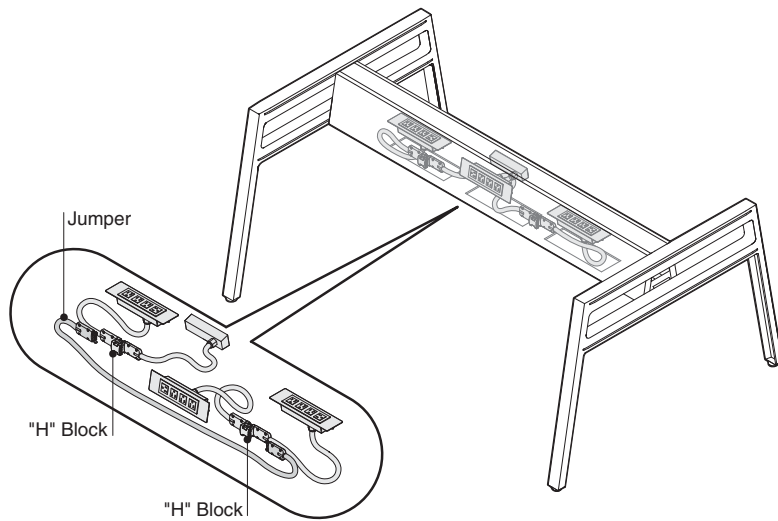

Modular hardwire power can support a maximum of six (6) powerways, TS2P260, per base power-in, TS2PBT2. After six (6) powerways a new base power-in will be required.

**Bivi Plug and Play and Modular Hardwire Power Routing Guide**

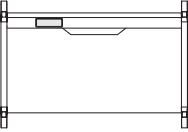
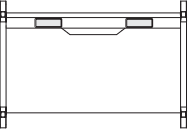
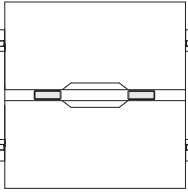
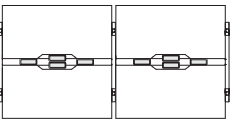
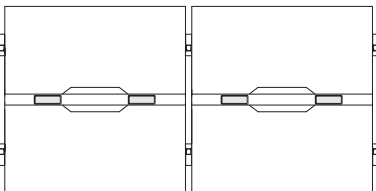
<b>Bivi Power Routing Guide</b>	<b>Plugs Per Person</b>	<b>Plug and Play Power Examples</b>	<b>Hardwired Power Examples (require authorized electrician)</b>
	(1) Table for One 4 plugs per person	(1) Package of one, TS2PS1PK	N.A.
	(1) Table for One 8 plugs per person	(1) Package of two, TS2PS2PK	(1) Powerway, Two Circuit, TS2P260 (1) Base Power-In, Hardwired, 2-circuit, TS2PBT2
	(1) Table for Two 4 plugs per person	(1) Package of two, TS2PS2PK	(1) Powerway, Two Circuit, TS2P260 (1) Base Power-In, Hardwired, 2-circuit, TS2PBT2
	(1) Table for Two 8 plugs per person	(1) Package of four, TS2PS4PK	(4) Powerway, Two Circuit, TS2P260 (3) Table-to-Table Connector, TS2PT2T (1) Base Power-In, Hardwired, 2-circuit, TS2PBT2 <i>*This configuration is not available for the 48" Bivi Tables.</i>
	(1) Table for Two (1) Table Plus Two 4 plugs per person	(1) Package of four, TS2PS4PK	(2) Powerway, Two Circuit, TS2P260 (1) Table-to-Table Connector, TS2PT2T (1) Base Power-In, Hardwired, 2-circuit, TS2PBT2

Note: In order to share hardwired powerways between two (2) tables in a stairstep application connectors are required.

Note: 48"W Bivi tables do not allow for four-pack hardwire power options.

# Storage

**Trunk storage** attaches to the end of a Bivi Table for Two. It has storage on each end as well as additional storage in the middle. Trunk is not approved to be used in a freestanding application or in a wall mount application.  
 ▶ Specifying, page 50

**Depot storage** is freestanding and comes in one-high, two-high, or three-high. Depot is not approved to be stacked on top of each other and cannot be wall mounted.

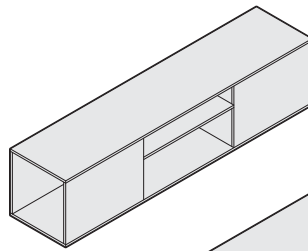

**Trunk**

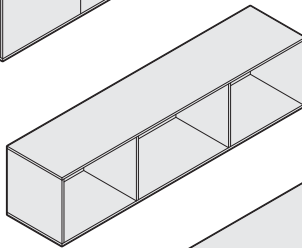

**Depot**

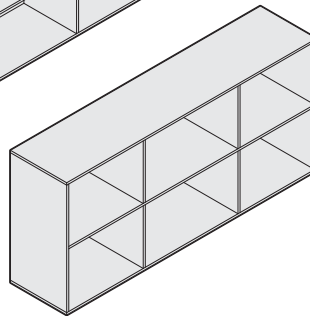

**Big Depot**

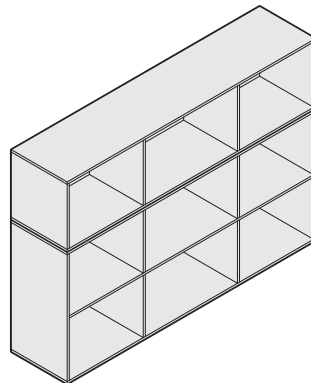

**Bigger Depot**

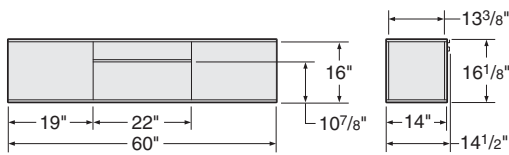

**Trunk**

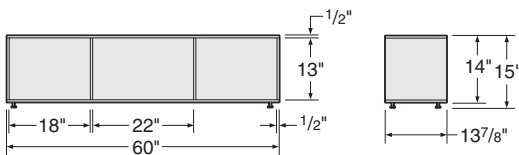

**Depot**

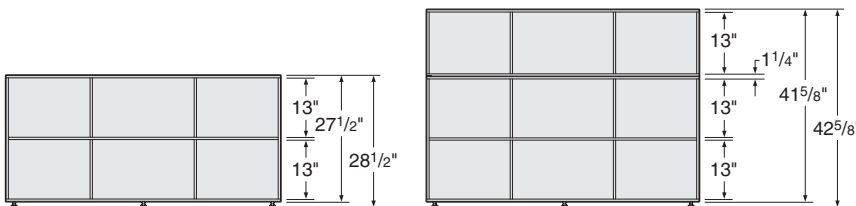

**Big Depot**

**Bigger Depot**

**Product Details**

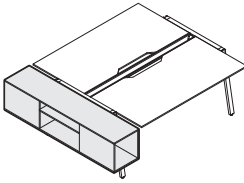

**Trunk storage** attaches to the end of a Bivi Table for Two. It has storage on each end as well as additional storage in the middle.

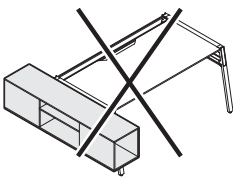

**Trunk** cannot be used on a Bivi Table for One.

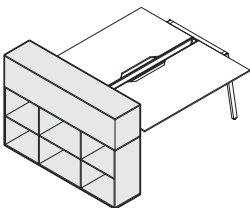
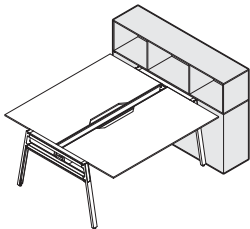

**Bigger Depot** has the ability to turn the top section around so it faces the table top when placed against the end of the Bivi table.

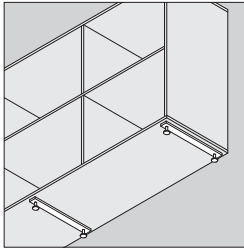

**Depot storage** comes with feet and adjustable glides on each end. Big Depot and Bigger Depot also come with an additional foot with adjustable glides in the center as well.

**Weight Capacities**

**Trunk:** 200 pounds on top, 50 pounds per cubby, and 25 pounds per shelf.

**Depots:** 200 pounds on top (all sizes) and 50 pounds per cubby (all sizes).

**Surface Materials**

**Trunk and Depot storage**

- Laminate

**Trunk shelves**

- Paint

# Arches and Accessories

Arches, Screens, Markerboards, Monitor Mount, Side Storage, Organizer, Bike Hook, Canopy, Board Rack, Holder, and Planter

**Arches** come in two sizes; Tall Arch and Short Arch. Arches have t-slots that run along the front and back of the Arches that are used to connect Bivi accessories. The Tall Arch has two levels to connect accessories.

**Holder** can be attached to the Tall Arch, Short Arch, a wall, or stand alone.  
 ▶ Specifying, page 54

**Board Rack** can be attached to the Tall Arch, Short Arch, or a wall. It can support maximum of 50 pounds.  
 ▶ Specifying, page 54

**Monitor Mounts** hold one monitor each up to 37" with a maximum of 50 pounds.  
 ▶ Specifying, page 52

**Arches** can be located on either end of a Bivi Table or in the middle of multiple Bivi Tables.  
 ▶ Specifying, page 54

**Bike Hooks** can be installed onto a Tall Arch or mounted onto a wall.  
 ▶ Specifying, page 53

**Screens** are shared between two users when installed on a Bivi Table for Two. Screens can accept magnetic accessories on both sides. Screens can be installed anywhere along the span of the cable trough.  
 ▶ Specifying, page 60

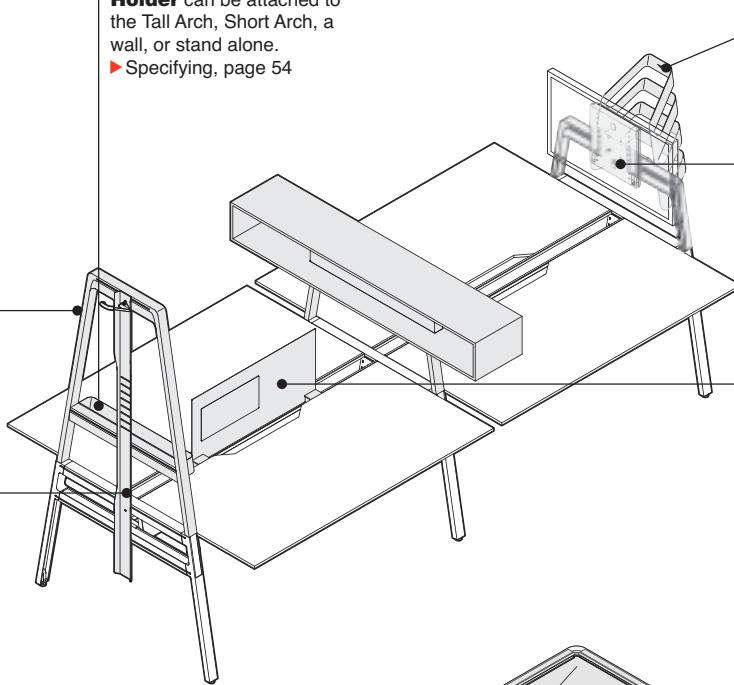

**Canopy** is standard with attachment hardware to connect to a Tall Arch.  
 ▶ Specifying, page 54

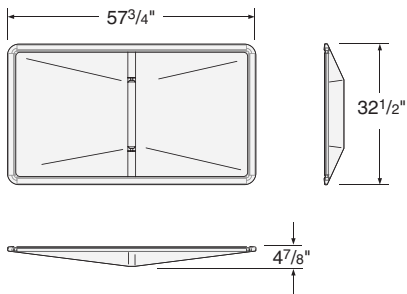
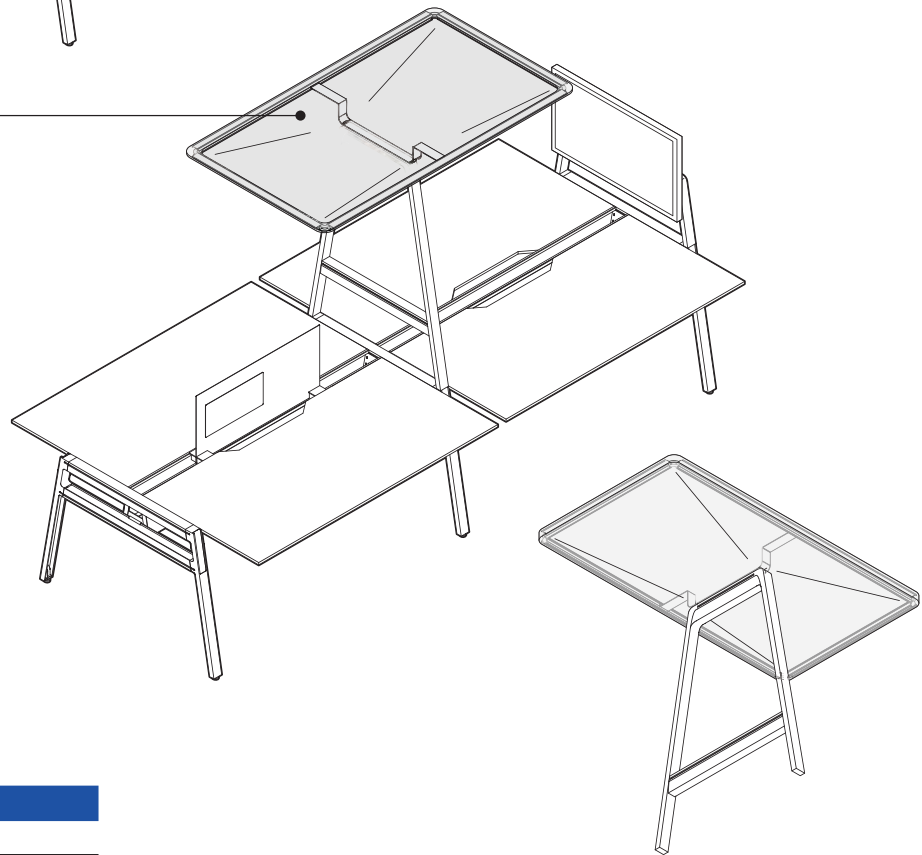

## Actual Dimensions

### Canopy

Height	4 7/8"
Depth	32 1/2"
Width	57 3/4"

**Product Details**

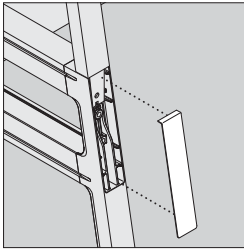

**Arches** ship standard with screw covers. They are a modified version of the screw covers that ship with Bivi Legs. When installing Arches, the Arch screw covers replace the leg screw covers.

*Tip: Save leg screw covers for future configurations. Both leg screw covers and Arch leg screw covers are supported as service parts.*

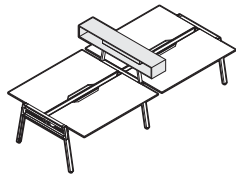

**Side Storage** installs onto a Short Arch and is shared between adjacent users. Each end of the Side Storage has open cubbys that can be left open or filled in with Bivi Organizers.

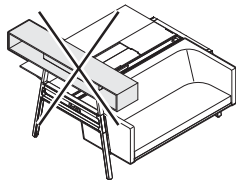

**Side Storage** should not be installed next to a Rumble Seat because it overhangs into the user sitting area.

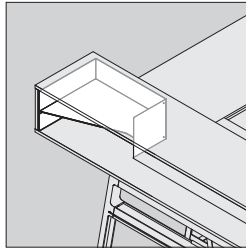

**Organizers** can be installed into each end of the Side Storage or used free-standing on a Table Top.

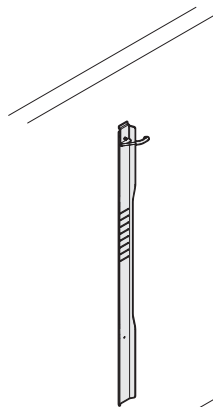

**Bike Hooks** can be mounted onto a wall.

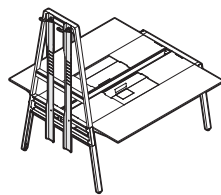

**Two Bike Hooks** can be installed on one Tall Arch as long as the two bikes do not exceed 100 pound maximum limit and the front tire and rear tire are alternated to avoid both sets of pedals in the same location.

*Tip: When ordering Bike Hooks there are separate style numbers depending on the desired application: TS2ARCHBH for arch mounted, TS2WALLBH for wall mounted.*

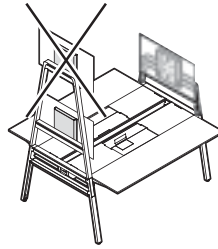

**Monitor Mounts** can be located at the top or bottom location of a Tall Arch and on a Short Arch. Only one monitor is allowed per side.

**Monitor Mounts** hold one monitor each up to 37" with a maximum of 50 pounds.

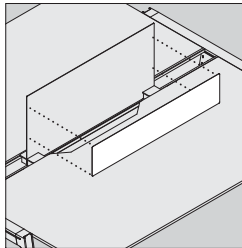

**Markerboards** are available in two sizes and have magnetic backs that work with steel surfaces such as the Bivi Screens and the center of the Bivi Side Storage.

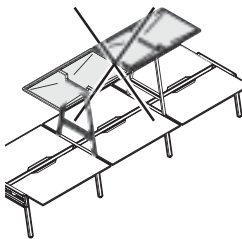

**Two canopies** cannot be used side-by-side on the 48"W Bivi tables.

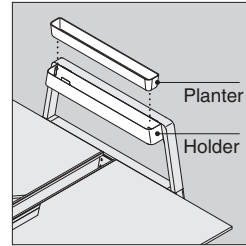

**Planter** is a waterproof insert that fits inside Holder to hold live plants.

**Holder or Holder with Planter** can be attached opposite of other Bivi accessories.

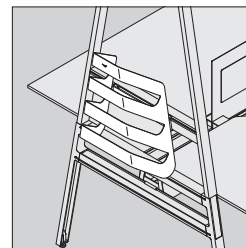

**Board Racks** can be attached at the bottom location of Tall Arch or a Short Arch.

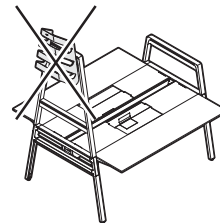

**Board Rack** can not be attached at the top location of a Tall Arch.

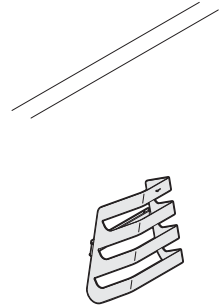

**Board Rack** can be attached to a wall.

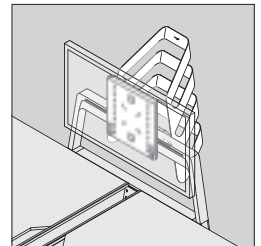

**Board Rack** can be attached opposite of a Monitor Mount.

**Connections**

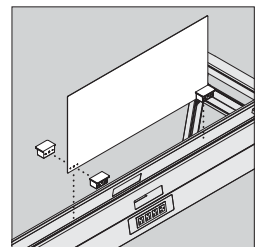

**Screens** ship with PUCKS that assemble by screwing two halves together and snapping into the Bivi Cable Trough.

Arches and Accessories, continued

**Connections**

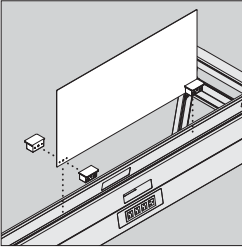

**Screens** ship with PUCKs that assemble by screwing two halves together and snapping into the Bivi Cable Trough.

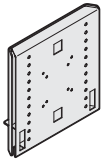

**Monitor Mounts** will support the following VESA\* patterns:

- 75 mm x 75 mm
- 100 mm x 100 mm
- 200 mm x 200 mm
- 200 mm x 100 mm

Screws for mounting the monitor to the Bivi monitor mount are not included. They should be included with the TV or monitor.

*\*VESA mount, is a family of standards defined by the Video Electronics Standards Association for mounting flat panel monitors, TVs, and other displays to stands or wall mounts.*

**Weight Capacities**

**Short Arch:** 100 pounds per side maximum.

**Tall Arch:** 100 pounds per side maximum.

**Monitor mount:** 50 pounds maximum.

**Side Storage:** 50 pounds bottom shelf/100 pounds top.

**Bike Hook:** 50 pounds maximum.

**Board Rack:** 50 pounds maximum.

**Holder:** 25 pounds maximum.

**Surface Materials**

**Arches, Monitor Mounts, screens, organizers, and Bike Hooks**

- Paint

**Screen PUCKs**

- Plastic

**Side Storage**

- Laminate and paint



# Rumble Seat and Hoodie

**Rumble Seat** comes with an option for either table frame attachment brackets or freestanding legs. Available in single fabric option for back and seat and Cal TB 133 Fire Code Seating.  
 ▶ Specifying, page 55

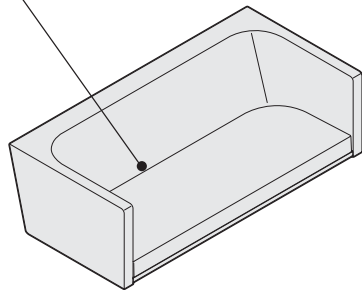

**Hoodie** is standard with attachment hardware to connect to a Rumble Seat. Available in a single fabric option for the top and sides and a default mesh on the back panel.  
 ▶ Specifying, page 56

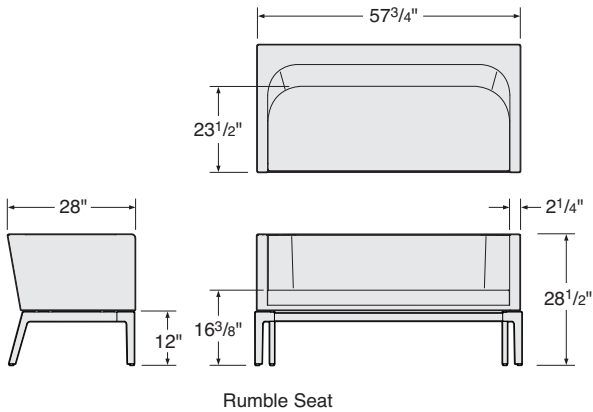
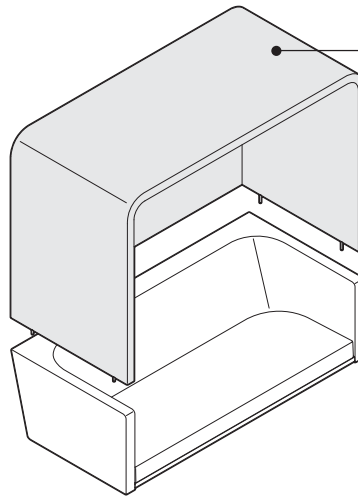

Rumble Seat

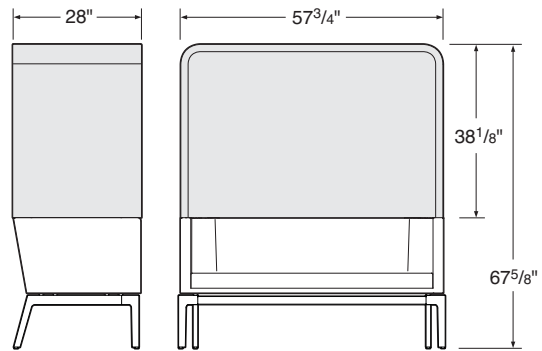

Hoodie

## Actual Dimensions

	Rumble Seat with freestanding legs or table frame attachment brackets	Freestanding Legs	Hoodie	Rumble Seat with Hoodie
Height	28 <sup>1</sup> / <sub>2</sub> "	12"	38 <sup>1</sup> / <sub>8</sub> "	67 <sup>5</sup> / <sub>8</sub> "
Seat Height	16 <sup>3</sup> / <sub>8</sub> "	N.A.	N.A.	N.A.
Depth	28"	28"	28"	28"
Seat Depth	23 <sup>1</sup> / <sub>2</sub> "	N.A.	N.A.	N.A.
Width	57 <sup>3</sup> / <sub>4</sub> "	58"	57 <sup>3</sup> / <sub>4</sub> "	58"

**Product Details**

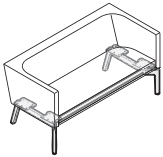

**Freestanding legs** connect to the bottom of the Rumble Seat.

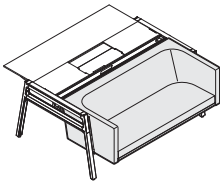

**Rumble Seats** can be installed on one or both sides of a Bivi Table for Two. To create this setting, order a Bivi Table for One and move the cable trough to the center. Install the table top on one side and the Rumble Seat on the other side.

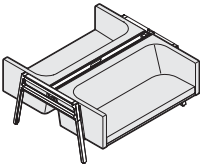

**Rumble Seats** can connect to a Bivi Table for Two on both sides. To create this setting, order a Rumble Seat with table frame attachment brackets (TS3RS), two Bivi legs (TS2RPBSL), and one Bivi cable trough (TS2RPCT).

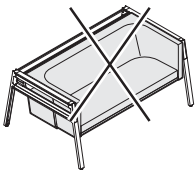

**Rumble Seats** cannot be installed in place of a work surface on a Bivi Table for One.  
*Tip: Rumble seat cannot be installed on 48"W Bivi Table for One or 48"W Bivi Table for Two.*

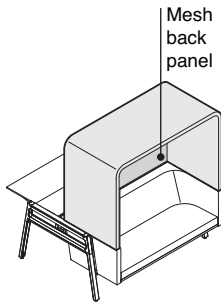

**Hoodie** is only intended to be used attached to a Rumble Seat.

**Hoodie** comes with two fabric options for the sides and top.

**Back panel on Hoodie** is defaulted in mesh. Mesh material used on the Hoodie back panel offers semi-transparency.

**Connections**

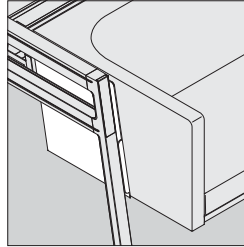

**Table frame attachment brackets** connect the Rumble Seat to the table frame in place of a table top on a Bivi Table for Two.

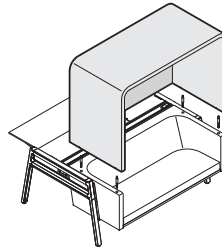

**Rumble Seats** have connectors that come standard to attach the Hoodie. These connectors need to be located and cut to expose them in order to attach the Hoodie. If you know ahead of time that a Hoodie will be installed, there is a style number that supports the Rumble Seat with the connectors exposed from the factory, TS3RSBKT.

**Surface Materials**

**Rumble Seats**

- Fabric

**Freestanding legs**

- Paint

**Table frame attachment brackets**

- Paint

**Hoodie**

- Fabric
- Mesh: T615 Sultry Smoke

# Components and Accessories

**Half-round table top** attaches to the end of a Bivi table.  
 ▶ Specifying, page 57

**Pocket covers** are laminate and can be ordered separately in order to enclose a back pocket. Each back pocket comes with two pocket covers that cover two thirds of the back pocket leaving one third of the opening to allow the pocket covers to slide side-to-side for easy access to stored items. Adding a third cover makes the appearance of a full table top.  
 ▶ Specifying, page 58

**Bottom shelf** attaches to the leg of a Bivi table. The bottom shelf can hold a CPU, backpack, computer bag, and other small items.  
 ▶ Specifying, page 59

**Hooks** attach to the leg of a Bivi table either under the desk or on the outside. Hooks also attach to a Bivi Arch. Hooks come in two-packs or four-packs.  
 ▶ Specifying, page 59

**Bivi leg** is available to order separately for reconfiguration purposes. In an existing benching application, you can take apart the table and add a leg to create two freestanding tables.  
 ▶ Specifying, page 58

**Adding** a half-round table top at the ends of a Bivi Table for Two creates a conference table.

**Top shelf** attaches to the cable trough. Three top shelves can span across a Bivi Table for One; up to six top shelves can be used on a Bivi Table for Two.  
 ▶ Specifying, page 59

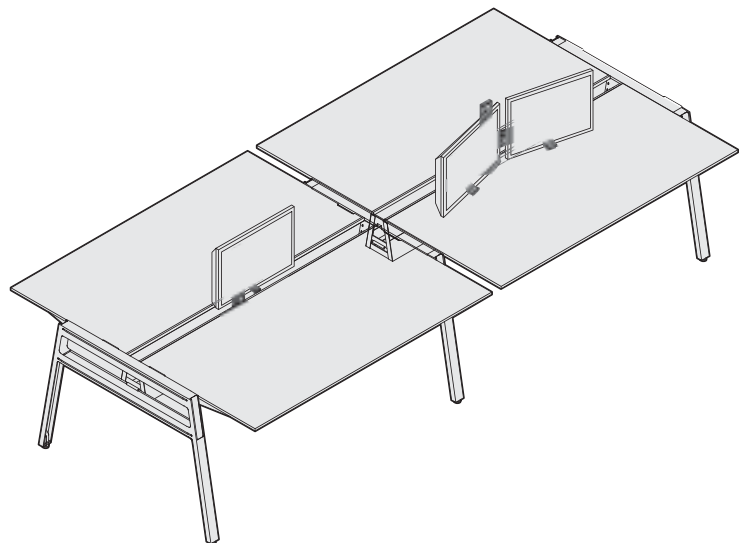
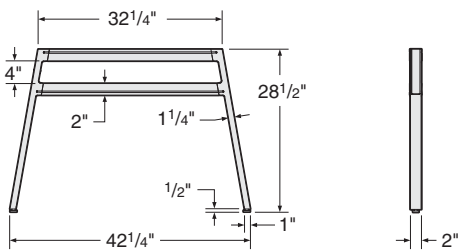
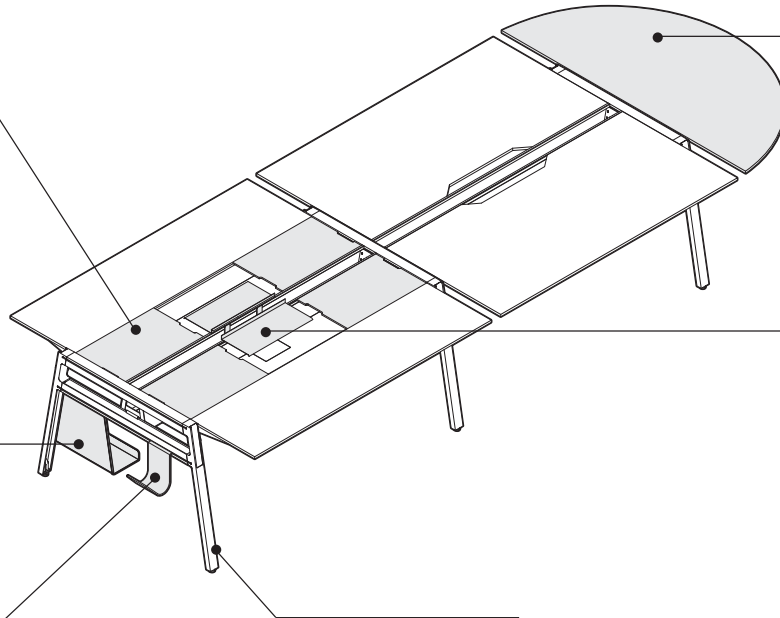

## Weight Capacities

Half Round Table Top	200 pounds
Hook	25 pounds
Top Shelf	30 pounds
Bottom Shelf	30 pounds

**Product Details**

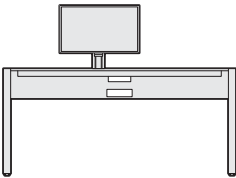
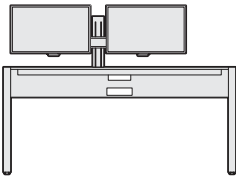
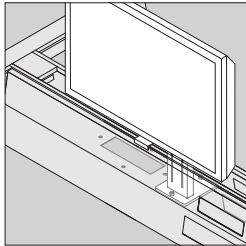

**Single and dual eyesite monitor arms** are available with a Bivi bracket that assembles in the Bivi trough.



**Half-round table top** will not work with a stand alone 48"W Bivi Table for Two.

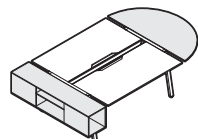
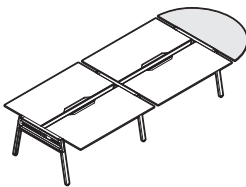

**Half-round table top** will work with 48" Bivi with additional product added to the other end. For example, add a Bivi Table or Trunk to a 48" Bivi Table for Two.

**Bivi Trough Accessory Install Guide**

**48" Bivi Tables**

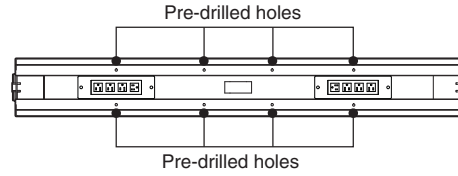

48" Bivi table trough has eight (8) predrilled hole patterns in the trough floor to accept accessories.

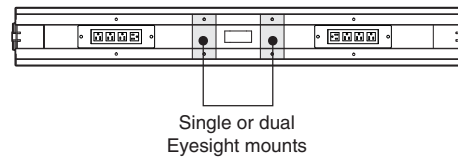

*Tip: End locations are not recommended for Eyesite dual monitors in the 48" or 60" Bivi tables.*  
*Tip: End locations are not recommended for Eyesite single monitor arms if power is installed.*

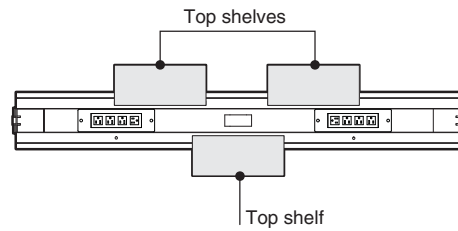

Possible top shelf locations.

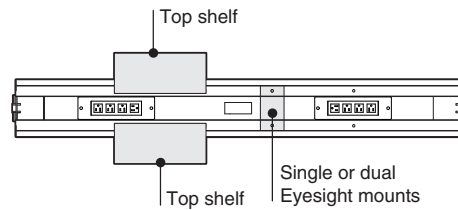

Example of mixing Eyesite monitor arms and top shelf accessories.

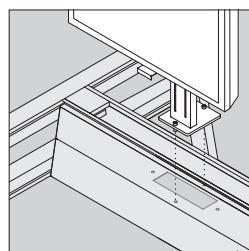

Eyesite single or dual monitor arms with a Bivi bracket take up two (2) of the holes across from each other.

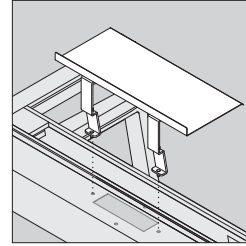

Shelves take up two (2) of the holes side by side.

**60" Bivi Tables**

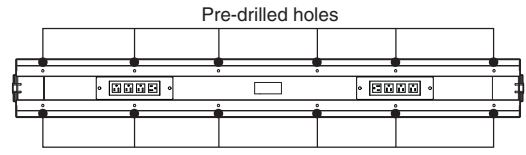

60" Bivi table trough has twelve (12) predrilled hole patterns in the trough floor to accept accessories.

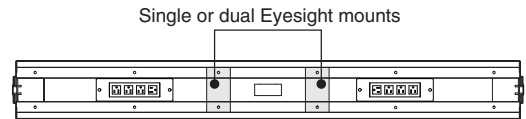

*Tip: End locations are not recommended for Eyesite dual monitors in the 48" or 60" Bivi tables.*  
*Tip: End locations are not recommended for Eyesite single monitor arms if power is installed.*

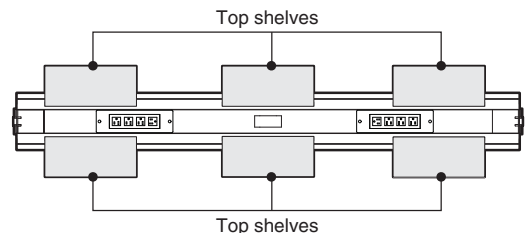

Possible top shelf locations. Up to six (6) shelves can be installed in one 60" Bivi trough.

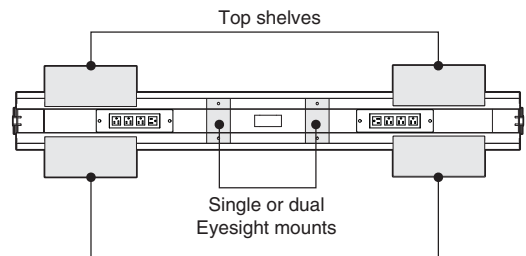

Example of mixing Eyesite monitor arms and top shelf accessories.

Components and Accessories, continued

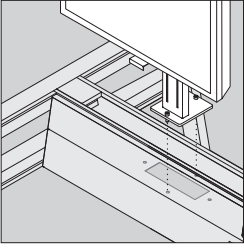

Eyesite single or dual monitor arms with a Bivi bracket take up two (2) of the holes across from each other.

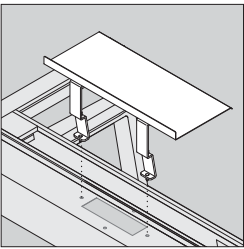

Shelves take up two (2) of the holes side by side.

# Tables

## Table for One

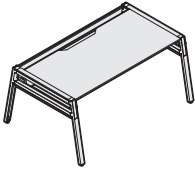

Tip: Bivi tables require assembly.

Tip: The plug and play power strips with data or USB option provide both three power with one data and three power with one port used for two USB plugs.

Tip: The USB and data option are always located in the fourth port location.

Standard Includes	Required to Specify
-------------------	---------------------

<ul style="list-style-type: none"> <li>▶ Need help? Product details, page 14</li> <li>• 1/2"-thick table top: Low-Pressure Laminate</li> <li>• Edge band: default color to match laminate</li> <li>• Two legs: paint</li> <li>• Cable trough: paint</li> </ul>	<ol style="list-style-type: none"> <li>1 Style number</li> <li>2 Low-Pressure Laminate color number for table top</li> <li>3 Paint color number for legs and cable trough</li> <li>4 Options, if selected (see below)</li> </ol> <p>▶ See <i>Surface Materials</i>, page 64.</p>
--	--

Power Kits	Options	U.S. Price	Required to Specify
------------	---------	------------	---------------------

<b>Package of two plug and play power kits</b>	• 2 pack: 8 power	+\$ 438	Specify with 2 pack: 8 power and select paint color number. Specify with 2 pack: 6 power, 2 data and select paint color number. Specify with 2 pack: 6 power, 1 USB, 1 data and select paint color number.
	• 2 pack: 6 power and 2 data	+\$ 438	
<b>Package of four plug and play power kits</b>	• 2 pack: 6 power, 1 USB, and 1 data	+\$ 494	Specify with 2 pack: 6 power, 2 USB and select paint color number. Specify with 4 pack: 16 power and select paint color number. Specify with 4 pack: 12 power, 4 data and select paint color number. Specify with 4 pack: 12 power, 2 USB, 2 data and select paint color number. Specify with 4 pack: 12 power, 4 USB and select paint color number.
	• 2 pack: 6 power and 2 USB	+\$ 550	
	• 4 pack: 16 power	+\$ 807	
	• 4 pack: 12 power and 4 data	+\$ 807	
	• 4 pack: 12 power, 2 USB, and 2 data	+\$ 919	
	• 4 pack: 12 power and 4 USB	+\$1031	

Specification Information				
Dimensions			Style	U.S.
D	W	H	Number	Base Price

42 1/4"	50"	28 1/2"	<b>TS2SDWF3048</b>	\$1499
42 1/4"	62"	28 1/2"	<b>TS2SDWF3060</b>	\$1524



**For Canadian Pricing**

Multiply U.S. Price by the Canadian price factor.

▶ See page 1 for details.

**Table Plus One**

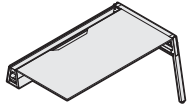

*Tip: Bivi tables require assembly.*

*Tip: Table Plus One must attach to another Bivi table for stability.*

*Tip: The plug and play power strips with data or USB option provide both three power with one data and three power with one port used for two USB plugs.*

*Tip: The USB and data option are always located in the fourth port location.*

Standard Includes	Required to Specify
-------------------	---------------------

<ul style="list-style-type: none"> <li>▶ Need help? Product details, page 14</li> <li>• 1/2"-thick table top: Low-Pressure Laminate</li> <li>• Edge band: default color to match laminate</li> <li>• One leg: paint</li> <li>• Cable trough: paint</li> </ul>	<ol style="list-style-type: none"> <li>1 Style number</li> <li>2 Low-Pressure Laminate color number for table top</li> <li>3 Paint color number for leg and cable trough</li> <li>4 Options, if selected (see below)</li> </ol> <p>▶ See <i>Surface Materials</i>, page 64.</p>
---	---

Power Kits	Options	U.S. Price	Required to Specify
------------	---------	------------	---------------------

<b>Power Kits</b>	<b>Package of two plug and play power kits</b>		
	<ul style="list-style-type: none"> <li>• 2 pack: 8 power +\$ 438</li> <li>• 2 pack: 6 power and 2 data +\$ 438</li> <li>• 2 pack: 6 power, 1 USB, and 1 data +\$ 494</li> <li>• 2 pack: 6 power and 2 USB +\$ 550</li> </ul>		<p>Specify with 2 pack: 8 power and select paint color number.</p> <p>Specify with 2 pack: 6 power, 2 data and select paint color number.</p> <p>Specify with 2 pack: 6 power, 1 USB, 1 data and select paint color number.</p> <p>Specify with 2 pack: 6 power, 2 USB and select paint color number.</p>
	<b>Package of four plug and play power kits</b>		
	<ul style="list-style-type: none"> <li>• 4 pack: 16 power +\$ 807</li> <li>• 4 pack: 12 power and 4 data +\$ 807</li> <li>• 4 pack: 12 power, 2 USB, and 2 data +\$ 919</li> <li>• 4 pack: 12 power and 4 USB +\$1031</li> </ul>		<p>Specify with 4 pack: 16 power and select paint color number.</p> <p>Specify with 4 pack: 12 power, 4 data and select paint color number.</p> <p>Specify with 4 pack: 12 power, 2 USB, 2 data and select paint color number.</p> <p>Specify with 4 pack: 12 power, 4 USB and select paint color number.</p>

Specification Information				
Dimensions			Style Number	U.S. Base Price
D	W	H		

42 1/4"	48"	28 1/2"	TS2SDAF3048	\$1171
42 1/4"	60"	28 1/2"	TS2SDAF3060	\$1194



**For Canadian Pricing**

Multiply U.S. Price by the Canadian price factor.

▶ See page 1 for details.

## Table for One with Back Pocket

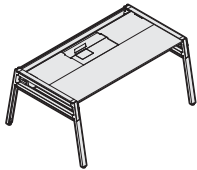

Tip: Bivi tables require assembly.

Tip: The plug and play power strips with data or USB option provide both three power with one data and three power with one port used for two USB plugs.

Tip: The USB and data option are always located in the fourth port location.

Standard Includes		Required to Specify
▶ Need help? Product details, page 14	<ul style="list-style-type: none"> <li>• 1/2"-thick table top: Low-Pressure Laminate</li> <li>• Edge band: default color to match laminate</li> <li>• Two legs: paint</li> <li>• Cable trough: paint</li> <li>• Back pocket: paint</li> <li>• Two pocket covers: Low-Pressure Laminate</li> </ul>	<ol style="list-style-type: none"> <li>1 Style number</li> <li>2 Low-Pressure Laminate color number for table top and pocket covers</li> <li>3 Paint color number for legs, back pocket, and cable trough</li> <li>4 Options, if selected (see below)</li> </ol> <p>▶ See <i>Surface Materials</i>, page 64.</p>

Options	U.S. Price	Required to Specify
<b>Power Kits</b>	<b>Package of two plug and play power kits</b>	
• 2 pack: 8 power	+\$ 438	Specify with 2 pack: 8 power and select paint color number.
• 2 pack: 6 power and 2 data	+\$ 438	Specify with 2 pack: 6 power, 2 data and select paint color number.
• 2 pack: 6 power, 1 USB, and 1 data	+\$ 494	Specify with 2 pack: 6 power, 1 USB, 1 data and select paint color number.
• 2 pack: 6 power and 2 USB	+\$ 550	Specify with 2 pack: 6 power, 2 USB and select paint color number.
	<b>Package of four plug and play power kits</b>	
• 4 pack: 16 power	+\$ 807	Specify with 4 pack: 16 power and select paint color number.
• 4 pack: 12 power and 4 data	+\$ 807	Specify with 4 pack: 12 power, 4 data and select paint color number.
• 4 pack: 12 power, 2 USB, and 2 data	+\$ 919	Specify with 4 pack: 12 power, 2 USB, 2 data and select paint color number.
• 4 pack: 12 power and 4 USB	+\$1031	Specify with 4 pack: 12 power, 4 USB and select paint color number.

Specification Information				
Dimensions			Style Number	U.S. Base Price
D	W	H		
42 1/4"	62"	28 1/2"	<b>TS2SDWS3060</b>	\$1784



### For Canadian Pricing

Multiply U.S. Price by the Canadian price factor.

▶ See page 1 for details.

**Table Plus One with Back Pocket**

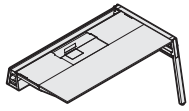

*Tip: Bivi tables require assembly.*

*Tip: The plug and play power strips with data or USB option provide both three power with one data and three power with one port used for two USB plugs.*

*Tip: The USB and data option are always located in the fourth port location.*

Standard Includes	Required to Specify
-------------------	---------------------

► Need help? Product details, page 14

- 1/2"-thick table top: Low-Pressure Laminate
- Edge band: default color to match laminate
- One leg: paint
- Cable trough: paint
- Back pocket: paint
- Two pocket covers: Low-Pressure Laminate

- 1 Style number
  - 2 Low-Pressure Laminate color number for table top and pocket covers
  - 3 Paint color number for leg, back pocket, and cable trough
  - 4 Options, if selected (see below)
- See *Surface Materials*, page 64.

Power Kits	Options	U.S. Price	Required to Specify
------------	---------	------------	---------------------

**Package of two plug and play power kits**

- 2 pack: 8 power +\$ 438
- 2 pack: 6 power and 2 data +\$ 438
- 2 pack: 6 power, 1 USB, and 1 data +\$ 494
- 2 pack: 6 power and 2 USB +\$ 550

Specify with 2 pack: 8 power and select paint color number.  
Specify with 2 pack: 6 power, 2 data and select paint color number.  
Specify with 2 pack: 6 power, 1 USB, 1 data and select paint color number.  
Specify with 2 pack: 6 power, 2 USB and select paint color number.

**Package of four plug and play power kits**

- 4 pack: 16 power +\$ 807
- 4 pack: 12 power and 4 data +\$ 807
- 4 pack: 12 power, 2 USB, and 2 data +\$ 919
- 4 pack: 12 power and 4 USB +\$1031

Specify with 4 pack: 16 power and select paint color number.  
Specify with 4 pack: 12 power, 4 data and select paint color number.  
Specify with 4 pack: 12 power, 2 USB, 2 data and select paint color number.  
Specify with 4 pack: 12 power, 4 USB and select paint color number.

Specification Information				
• Dimensions			• Style	• U.S.
D	W	H	Number	Base Price

42¼"	60"	28½"	<b>TS2SDAS3060</b>	\$1454
------	-----	------	--------------------	--------



**For Canadian Pricing**

Multiply U.S. Price by the Canadian price factor.

► See page 1 for details.

## Table for Two

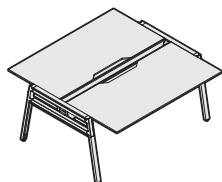

Tip: Bivi tables require assembly.

Tip: The plug and play power strips with data or USB option provide both three power with one data and three power with one port used for two USB plugs.

Tip: The USB and data option are always located in the fourth port location.

Standard Includes	Required to Specify
<ul style="list-style-type: none"> <li>▶ Need help? Product details, page 14</li> <li>• Two, 1/2"-thick table tops: Low-Pressure Laminate</li> <li>• Edge band: default color to match laminate</li> <li>• Two legs: paint</li> <li>• Cable trough: paint</li> </ul>	<ol style="list-style-type: none"> <li>1 Style number</li> <li>2 Low-Pressure Laminate color number for table tops</li> <li>3 Paint color number for legs and cable trough</li> <li>4 Options, if selected (see below)</li> </ol> <p>▶ See <i>Surface Materials</i>, page 64.</p>

Options	U.S. Price	Required to Specify
<b>Power Kits</b>		
<b>Package of two plug and play power kits</b>		
• 2 pack: 8 power	+\$ 438	Specify with 2 pack: 8 power and select paint color number.
• 2 pack: 6 power and 2 data	+\$ 438	Specify with 2 pack: 6 power, 2 data and select paint color number.
• 2 pack: 6 power, 1 USB, and 1 data	+\$ 494	Specify with 2 pack: 6 power, 1 USB, 1 data and select paint color number.
• 2 pack: 6 power and 2 USB	+\$ 550	Specify with 2 pack: 6 power, 2 USB and select paint color number.
<b>Package of four plug and play power kits</b>		
• 4 pack: 16 power	+\$ 807	Specify with 4 pack: 16 power and select paint color number.
• 4 pack: 12 power and 4 data	+\$ 807	Specify with 4 pack: 12 power, 4 data and select paint color number.
• 4 pack: 12 power, 2 USB, and 2 data	+\$ 919	Specify with 4 pack: 12 power, 2 USB, 2 data and select paint color number.
• 4 pack: 12 power and 4 USB	+\$1031	Specify with 4 pack: 12 power, 4 USB and select paint color number.

Specification Information				
Dimensions			Style Number	U.S. Base Price
D	W	H		
60"	50"	28½"	<b>TS2TTWF3048</b>	\$1874
60"	62"	28½"	<b>TS2TTWF3060</b>	\$1896

 **For Canadian Pricing**  
 Multiply U.S. Price by the Canadian price factor.  
 ▶ See page 1 for details.

**Table Plus Two**

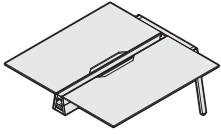

Tip: Bivi tables require assembly.

Tip: Table Plus Two must attach to another Bivi table for stability.

Tip: The plug and play power strips with data or USB option provide both three power with one data and three power with one port used for two USB plugs.

Tip: The USB and data option are always located in the fourth port location.

Standard Includes	Required to Specify
-------------------	---------------------

<ul style="list-style-type: none"> <li>▶ Need help? Product details, page 14</li> <li>• Two, 1/2"-thick table tops: Low-Pressure Laminate</li> <li>• Edge band: default color to match laminate</li> <li>• One leg: paint</li> <li>• Cable trough: paint</li> </ul>	<ol style="list-style-type: none"> <li>1 Style number</li> <li>2 Low-Pressure Laminate color number for table top</li> <li>3 Paint color number for leg and cable trough</li> <li>4 Options, if selected (see below)</li> </ol> <p>▶ See <i>Surface Materials</i>, page 64.</p>
---	---

Power Kits	Options	U.S. Price	Required to Specify
------------	---------	------------	---------------------

<b>Power Kits</b>	<b>Package of two plug and play power kits</b>		
	<ul style="list-style-type: none"> <li>• 2 pack: 8 power +\$ 438</li> <li>• 2 pack: 6 power and 2 data +\$ 438</li> <li>• 2 pack: 6 power, 1 USB, and 1 data +\$ 494</li> <li>• 2 pack: 6 power and 2 USB +\$ 550</li> </ul>		<p>Specify with 2 pack: 8 power and select paint color number.</p> <p>Specify with 2 pack: 6 power, 2 data and select paint color number.</p> <p>Specify with 2 pack: 6 power, 1 USB, 1 data and select paint color number.</p> <p>Specify with 2 pack: 6 power, 2 USB and select paint color number.</p>
	<b>Package of four plug and play power kits</b>		
	<ul style="list-style-type: none"> <li>• 4 pack: 16 power +\$ 807</li> <li>• 4 pack: 12 power and 4 data +\$ 807</li> <li>• 4 pack: 12 power, 2 USB, and 2 data +\$ 919</li> <li>• 4 pack: 12 power and 4 USB +\$1031</li> </ul>		<p>Specify with 4 pack: 16 power and select paint color number.</p> <p>Specify with 4 pack: 12 power, 4 data and select paint color number.</p> <p>Specify with 4 pack: 12 power, 2 USB, 2 data and select paint color number.</p> <p>Specify with 4 pack: 12 power, 4 USB and select paint color number.</p>

Specification Information				
• Dimensions			• Style	• U.S.
D	W	H	Number	Base Price

60"	48"	28½"	<b>TS2TTAF3048</b>	\$1538
60"	60"	28½"	<b>TS2TTAF3060</b>	\$1558



**For Canadian Pricing**  
 Multiply U.S. Price by the Canadian price factor.  
 ▶ See page 1 for details.

## Table for Two with Back Pockets

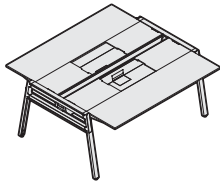

Tip: Bivi tables require assembly.

Tip: The plug and play power strips with data or USB option provide both three power with one data and three power with one port used for two USB plugs.

Tip: The USB and data option are always located in the fourth port location.

Standard Includes	Required to Specify
-------------------	---------------------

- |  |  |
|--|--|
| <ul style="list-style-type: none"> <li>▶ Need help? Product details, page 14</li> <li>• Two, 1/2"-thick table tops: Low-Pressure Laminate</li> <li>• Edge band: default color to match laminate</li> <li>• Two legs: paint</li> <li>• Cable trough: paint</li> <li>• Two back pockets: paint</li> <li>• Four pocket covers: Low-Pressure Laminate</li> </ul> | <ul style="list-style-type: none"> <li>1 Style number</li> <li>2 Low-Pressure Laminate color number for table tops and pocket covers</li> <li>3 Paint color number for legs, back pockets, and cable trough</li> <li>4 Options, if selected (see below)</li> <li>▶ See <i>Surface Materials</i>, page 64.</li> </ul> |
|--|--|

Power Kits	Options	U.S. Price	Required to Specify
------------	---------	------------	---------------------

- |  |  |  |  |
|--|--|--|--|
|  | <b>Package of two plug and play power kits</b>   |  |  |
|  | <ul style="list-style-type: none"> <li>• 2 pack: 8 power +\$ 438</li> <li>• 2 pack: 6 power and 2 data +\$ 438</li> <li>• 2 pack: 6 power, 1 USB, and 1 data +\$ 494</li> <li>• 2 pack: 6 power and 2 USB +\$ 550</li> </ul>     |  | Specify with 2 pack: 8 power and select paint color number.<br>Specify with 2 pack: 6 power, 2 data and select paint color number.<br>Specify with 2 pack: 6 power, 1 USB, 1 data and select paint color number.<br>Specify with 2 pack: 6 power, 2 USB and select paint color number.     |
|  | <b>Package of four plug and play power kits</b>  |  |  |
|  | <ul style="list-style-type: none"> <li>• 4 pack: 16 power +\$ 807</li> <li>• 4 pack: 12 power and 4 data +\$ 807</li> <li>• 4 pack: 12 power, 2 USB, and 2 data +\$ 919</li> <li>• 4 pack: 12 power and 4 USB +\$1031</li> </ul> |  | Specify with 4 pack: 16 power and select paint color number.<br>Specify with 4 pack: 12 power, 4 data and select paint color number.<br>Specify with 4 pack: 12 power, 2 USB, 2 data and select paint color number.<br>Specify with 4 pack: 12 power, 4 USB and select paint color number. |

Specification Information				
Dimensions			Style	U.S.
D	W	H	Number	Base Price

60"	62"	28 1/2"	<b>TS2TTWS3060</b>	\$2286
-----	-----	---------	--------------------	--------



**For Canadian Pricing**  
 Multiply U.S. Price by the Canadian price factor.  
 ▶ See page 1 for details.

**Table Plus Two with Back Pockets**

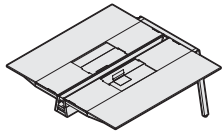

Tip: Bivi tables require assembly.

Tip: Bivi Table Plus Two with Back Pockets must attach to another Bivi table for stability.

Tip: The plug and play power strips with data or USB option provide both three power with one data and three power with one port used for two USB plugs.

Tip: The USB and data option are always located in the fourth port location.

Standard Includes	Required to Specify
<ul style="list-style-type: none"> <li>▶ Need help? Product details, page 14</li> <li>• Two, 1/2"-thick table tops: Low-Pressure Laminate</li> <li>• Edge band: default color to match laminate</li> <li>• One leg: paint</li> <li>• Cable trough: paint</li> <li>• Two back pockets: paint</li> <li>• Four pocket covers: Low-Pressure Laminate</li> </ul>	<ul style="list-style-type: none"> <li>1 Style number</li> <li>2 Low-Pressure Laminate color number for table tops and pocket covers</li> <li>3 Paint color number for leg, back pocket, and cable trough</li> <li>4 Options, if selected (see below)</li> <li>▶ See <i>Surface Materials</i>, page 64.</li> </ul>

Options	U.S. Price	Required to Specify
<b>Power Kits</b>		
<b>Package of two plug and play power kits</b>		
• 2 pack: 8 power	+\$ 438	Specify with 2 pack: 8 power and select paint color number.
• 2 pack: 6 power and 2 data	+\$ 438	Specify with 2 pack: 6 power, 2 data and select paint color number.
• 2 pack: 6 power, 1 USB, and 1 data	+\$ 494	Specify with 2 pack: 6 power, 1 USB, 1 data and select paint color number.
• 2 pack: 6 power and 2 USB	+\$ 550	Specify with 2 pack: 6 power, 2 USB and select paint color number.
<b>Package of four plug and play power kits</b>		
• 4 pack: 16 power	+\$ 807	Specify with 4 pack: 16 power and select paint color number.
• 4 pack: 12 power and 4 data	+\$ 807	Specify with 4 pack: 12 power, 4 data and select paint color number.
• 4 pack: 12 power, 2 USB, and 2 data	+\$ 919	Specify with 4 pack: 12 power, 2 USB, 2 data and select paint color number.
• 4 pack: 12 power and 4 USB	+\$1031	Specify with 4 pack: 12 power, 4 USB and select paint color number.

Specification Information				
• Dimensions			• Style	• U.S.
D	W	H	Number	Base Price
60"	60"	28 1/2"	<b>TS2TTAS3060</b>	\$1912



**For Canadian Pricing**  
 Multiply U.S. Price by the Canadian price factor.  
 ▶ See page 1 for details.



# Electrical Components

## Plug and Play Power Kits

*Tip: The plug and play power strips with data or USB option provide both three power with one data and three power with one port used for two USB plugs.*

*Tip: The USB and data option are always located in the fourth port location.*

Standard Includes	Required to Specify
<ul style="list-style-type: none"> <li>▶ Need help? Product details, page 20</li> <li>• Power kit: paint</li> <li>• 12-amp system rating</li> <li>• 15-amp power cord with 15-amp over-current protection</li> <li>• 10' long cord with wall plug</li> <li>• 5' cord length between power strips</li> <li>• UL recognized Powered Table System Component per UL962</li> </ul>	<ul style="list-style-type: none"> <li>1 Style number</li> <li>2 Paint color number for power kit</li> <li>3 Options, if selected (see below)</li> <li>▶ See <i>Surface Materials</i>, page 64.</li> </ul>

Power Kits	Options	U.S. Price	Required to Specify
	<b>Package of one plug and play power kit</b>		
	• 1 pack: 4 power	No cost	Specify with 1 pack: 4 power and select paint color number.
	• 1 pack: 3 power and 1 data	No cost	Specify with 1 pack: 3 power, 1 data and select paint color number.
	• 1 pack: 3 power and 1 USB	+\$ 56	Specify with 1 pack: 3 power, 1 USB and select paint color number.
	<b>Package of two plug and play power kits</b>		
	• 2 pack: 8 power	No cost	Specify with 2 pack: 8 power and select paint color number.
	• 2 pack: 6 power and 2 data	No cost	Specify with 2 pack: 6 power, 2 data and select paint color number.
	• 2 pack: 6 power, 1 USB, and 1 data	+\$ 56	Specify with 2 pack: 6 power, 1 USB, 1 data and select paint color number.
	• 2 pack: 6 power and 2 USB	+\$112	Specify with 2 pack: 6 power, 2 USB and select paint color number.
	<b>Package of four plug and play power kits</b>		
	• 4 pack: 16 power	No cost	Specify with 4 pack: 16 power and select paint color number.
	• 4 pack: 12 power and 4 data	No cost	Specify with 4 pack: 12 power, 4 data and select paint color number.
	• 4 pack: 12 power, 2 USB, and 2 data	+\$112	Specify with 4 pack: 12 power, 2 USB, 2 data and select paint color number.
	• 4 pack: 12 power and 4 USB	+\$224	Specify with 4 pack: 12 power, 4 USB and select paint color number.

### Specification Information

• Total Receptacles	• Style Number	• U.S. Base Price

### Package of One

4	TS2PS1PK	\$227

### Package of Two

8	TS2PS2PK	\$438

▶ **Specification Information, continued on next page**

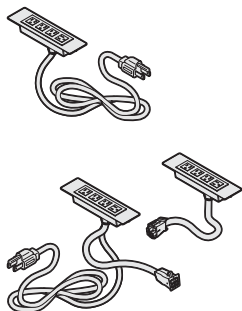

**For Canadian Pricing**  
 Multiply U.S. Price by the Canadian price factor.  
 ▶ See page 1 for details.

► **Specification Information, continued from previous page**

**Specification Information**

Total Receptacles	Style Number	U.S. Price
-------------------	--------------	------------

**Package of Four**

16	<b>TS2PS4PK</b>	\$807
----	-----------------	-------

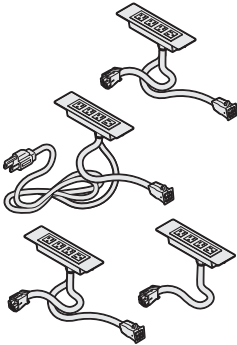

Bivi

**Accessory Base Power-Ins**

	Standard Includes	Required to Specify
► Need help? Product details, page 20	<ul style="list-style-type: none"> <li>2-circuit hardwired base power-in, 3/8" diameter flexible galvanized steel conduit, liquid tight conduit outside of cable trough</li> <li>Modular connection for 2-circuit powerways</li> <li>In-line connector to allow connection at middle of run</li> <li>San Francisco hardwired base power-in, 3/8" diameter flexible galvanized steel conduit, liquid tight conduit outside of cable trough</li> </ul>	Style number

**Specification Information**

Style Number	U.S. Price
--------------	------------

**Accessory Base Power-In, Hardwired, Two Circuit, Line 1 and Line 2**

<b>TS2PBT2</b>	\$128
----------------	-------

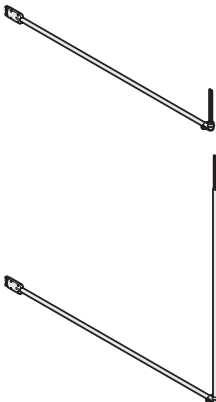

**Accessory Base Power-In, Hardwired, San Francisco, Two Circuit, Line 1 and Line 2**

<b>TS2PBT2SF</b>	\$161
------------------	-------



**For Canadian Pricing**  
 Multiply U.S. Price by the Canadian price factor.  
 ► See page 1 for details.

## Hardwired Powerways

*Tip: The plug and play power strips with data or USB option provide both three power with one data and three power with one port used for two USB plugs.*

*Tip: The USB and data option are always located in the fourth port location.*

Standard Includes	Required to Specify
<ul style="list-style-type: none"> <li>▶ Need help? Product details, page 20</li> <li>• 60" powerway with 8 total receptacles: paint</li> <li>• 2-circuit powerways</li> <li>• 60" powerway for 2-circuit with (1) line 1 and (1) line 2 receptacles</li> <li>• Chicago hardwired junction boxes with 8 total receptacles: 6000 Black plastic default</li> <li>• Shipped ready to install</li> </ul>	<ul style="list-style-type: none"> <li>1 Style number</li> <li>2 Paint color number for powerway</li> <li>3 Options, if selected (see below)</li> <li>▶ See <i>Surface Materials</i>, page 64.</li> </ul>

Power Kits	Options	U.S. Price	Required to Specify
	<b>Package of two plug and play power kits</b>		
	• 2 pack: 8 power	No cost	Specify with 2 pack: 8 power and select paint color number.
	• 2 pack: 6 power and 2 data	No cost	Specify with 2 pack: 6 power, 2 data and select paint color number.
	• 2 pack: 6 power, 1 USB, and 1 data	+\$ 56	Specify with 2 pack: 6 power, 1 USB, 1 data and select paint color number.
	• 2 pack: 6 power and 2 USB	+\$112	Specify with 2 pack: 6 power, 2 USB and select paint color number.

Specification Information	
Style Number	U.S. Base Price

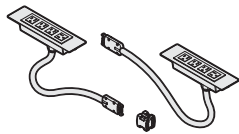

### Hardwired Powerway, Two Circuit - Line 1 and Line 2

<b>TS2P260</b>	\$509
----------------	-------

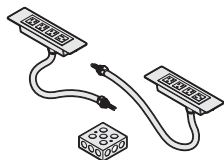

### Hardwired Powerway, Chicago, Two Circuit - Line 1 and Line 2

<b>TS2P2CHI</b>	\$509
-----------------	-------

*Tip: 48"W Bivi tables only allow for one modular hard-wire powerway, TS2P260, or for one Chicago hardwire powerway. Each powerway comes with two strips for a total of eight plugs.*



#### For Canadian Pricing

Multiply U.S. Price by the Canadian price factor.

▶ See page 1 for details.

### Table-to-Table Power Connector, 1-Circuit and 2-Circuit

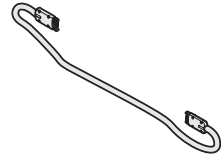

Standard Includes	Required to Specify
<ul style="list-style-type: none"> <li>Need help? Product details, page 20</li> <li>Modular table-to-table power connector</li> </ul>	Style number

#### Specification Information

Style Number	U.S. Price
TS2PT2T	\$76

 **For Canadian Pricing**  
 Multiply U.S. Price by the Canadian price factor.  
 ▶ See page 1 for details.

# Storage

## Trunk

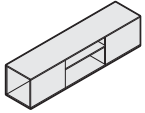

Tip: Trunks come fully assembled.

Tip: Trunk cannot be used on a Bivi Table for One.

Standard Includes		Required to Specify
▶ Need help? Product details, page 26	<ul style="list-style-type: none"> <li>• Trunk: Low-Pressure Laminate</li> <li>• Shelves: paint</li> <li>• Attachment hardware</li> </ul>	1 Style number 2 Low-Pressure Laminate color number for Trunk 3 Paint color number for shelves ▶ See <i>Surface Materials</i> , page 64.

Related Products	
• Bivi Table for Two	▶ Page 41

Specification Information				
Dimensions			Style Number	U.S. Price
D	W	H		
14"	60"	16"	<b>TS2STEH1660</b>	\$1093

## Depot

Tip: Depot storage requires assembly.

Standard Includes		Required to Specify
▶ Need help? Product details, page 26	<ul style="list-style-type: none"> <li>• Depot: laminate</li> <li>• Feet with adjustable glides</li> <li>• Attachment hardware</li> </ul>	1 Style number 2 Laminate color number for Depot ▶ See <i>Surface Materials</i> , page 64.

Specification Information				
Dimensions			Style Number	U.S. Price
D	W	H		

Depot				
13 <sup>7</sup> / <sub>8</sub> "	60"	15"	<b>TS2ST1H1460</b>	\$ 748

Big Depot				
13 <sup>7</sup> / <sub>8</sub> "	60"	28 <sup>1</sup> / <sub>2</sub> "	<b>TS2ST2H2860</b>	\$1176

Bigger Depot				
13 <sup>7</sup> / <sub>8</sub> "	60"	42"	<b>TS2ST2H4260</b>	\$1819

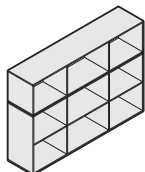
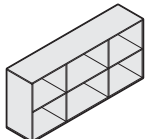
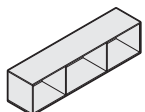

**For Canadian Pricing**  
 Multiply U.S. Price by the Canadian price factor.  
 ▶ See page 1 for details.

Tip: Arch requires assembly.

Standard Includes	Required to Specify
<ul style="list-style-type: none"> <li>▶ Need help? Product details, page 28</li> <li>• Arch: paint</li> <li>• Attachment hardware</li> <li>• Ships ready to assemble</li> </ul>	<ul style="list-style-type: none"> <li>1 Style number</li> <li>2 Paint color number for Arch</li> <li>▶ See <i>Surface Materials</i>, page 64.</li> </ul>

Related Products	
<ul style="list-style-type: none"> <li>• Side Storage</li> <li>• Monitor Mount</li> <li>• Bike Hook</li> </ul>	<ul style="list-style-type: none"> <li>▶ Page 52</li> <li>▶ Page 52</li> <li>▶ Page 53</li> </ul>

### Specification Information

Dimensions			Style	U.S.
D	W	H	Number	Price

#### Short Arch

2"	32 <sup>3</sup> / <sub>8</sub> "	13"	<b>TS2ARCHL</b>	\$414
----	----------------------------------	-----	-----------------	-------

#### Tall Arch

2"	32 <sup>3</sup> / <sub>8</sub> "	44"	<b>TS2ARCHT</b>	\$580
----	----------------------------------	-----	-----------------	-------



 **For Canadian Pricing**  
 Multiply U.S. Price by the Canadian price factor.  
 ▶ See page 1 for details.

# Arch Accessories

## Side Storage

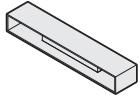

*Tip: Side storage is used only on Bivi Short Arch. It is not designed to work freestanding.*

Standard Includes	Required to Specify
-------------------	---------------------

- |   |   |   |
|---|---|---|
| ▶ Need help?<br>Product details,<br>page 28 | <ul style="list-style-type: none"> <li>• Side Storage: Low-Pressure Laminate</li> <li>• Center steel: paint</li> <li>• Attachment hardware</li> </ul> | <ul style="list-style-type: none"> <li>1 Style number</li> <li>2 Low-Pressure Laminate for Side Storage</li> <li>3 Paint color number for center steel</li> <li>▶ See <i>Surface Materials</i>, page 64.</li> </ul> |
|---|---|---|

Related Products
------------------

- |  |  |
|--|--|
| <ul style="list-style-type: none"> <li>• Magnetic Markerboards</li> <li>• Organizer</li> </ul> | <ul style="list-style-type: none"> <li>▶ Page 53</li> <li>▶ Page 60</li> </ul> |
|--|--|

Specification Information				
• Dimensions			• Style	• U.S.
D	W	H	Number	Price

11 1/2"	60"	8"	<b>TS2ARCHSIDE</b>	\$622
:	:	:	:	:

## Monitor Mount



*Tip: Monitor Mount requires assembly.*

Standard Includes	Required to Specify
-------------------	---------------------

- |   |  |  |
|---|--|--|
| ▶ Need help?<br>Product details,<br>page 28 | <ul style="list-style-type: none"> <li>• Monitor Mount: black paint</li> </ul> | <ul style="list-style-type: none"> <li>Style number</li> </ul> |
|---|--|--|

Specification Information				
• Dimensions			• Style	• U.S.
D	W	H	Number	Price

2 1/2"	12"	12 1/8"	<b>TS2ARCHMM</b>	\$414
:	:	:	:	:



**For Canadian Pricing**  
Multiply U.S. Price by the Canadian price factor.  
▶ See page 1 for details.

## Bike Hook

Standard Includes		Required to Specify
<ul style="list-style-type: none"> <li>▶ Need help? Product details, page 28</li> </ul>	<ul style="list-style-type: none"> <li>• Bike Hook: paint</li> <li>• Attachment hardware for wall or arch mount</li> <li>• Ships ready to assemble</li> </ul>	<ul style="list-style-type: none"> <li>1 Style number</li> <li>2 Paint color number for Bike Hook</li> <li>▶ See <i>Surface Materials</i>, page 64.</li> </ul>

Specification Information				
Dimensions			Style	U.S.
D	W	H	Number	Price

### Bike Hook-Arch Mount

51/8"	4"	60"	<b>TS2ARCHBH</b>	\$268
:	:	:	:	:

### Bike Hook-Wall Mount

51/8"	4"	60"	<b>TS2WALLBH</b>	\$268
:	:	:	:	:



Tip: A wall mount cannot be changed to an Arch mount.

## Markerboards

Standard Includes		Required to Specify
<ul style="list-style-type: none"> <li>▶ Need help? Product details, page 28</li> </ul>	<ul style="list-style-type: none"> <li>• Magnetic markerboard: 6650 Sodium</li> </ul>	<ul style="list-style-type: none"> <li>Style number</li> </ul>

Related Products	
<ul style="list-style-type: none"> <li>• Side Storage</li> <li>• Screen</li> </ul>	<ul style="list-style-type: none"> <li>▶ Page 52</li> <li>▶ Page 60</li> </ul>

Specification Information				
Dimensions		Style	U.S.	
W	H	Number	Price	
14"	67/8"	<b>TS2MB14</b>	\$102	
30"	6"	<b>TS2MB30</b>	\$123	
:	:	:	:	



Tip: Markerboards require assembly.

 **For Canadian Pricing**  
 Multiply U.S. Price by the Canadian price factor.  
 ▶ See page 1 for details.

### Canopy



Tip: Canopy requires a Tall Arch.

Tip: Two canopies cannot be used side-by-side on the 48"W Bivi tables.

Standard Includes		Required to Specify
▶ Need help? Product details, page 28	<ul style="list-style-type: none"> <li>Aluminum frame and mounting hardware</li> <li>White fabric: 5VD0 Bivi Canopy Fabric</li> </ul>	Style number

Specification Information				
Dimensions			Style Number	U.S. Price
D	W	H		
32 <sup>1</sup> / <sub>2</sub> "	57 <sup>3</sup> / <sub>4</sub> "	47 <sup>1</sup> / <sub>8</sub> "	<b>TS2ARCHC</b>	\$456

### Board Rack



Standard Includes		Required to Specify
▶ Need help? Product details, page 28	<ul style="list-style-type: none"> <li>Board Rack: paint</li> <li>Attachment hardware for wall or arch mount</li> </ul>	1 Style number 2 Paint color number for Board Rack ▶ See <i>Surface Materials</i> , page 64.

Specification Information				
Dimensions			Style Number	U.S. Price
D	W	H		
8"	17 <sup>1</sup> / <sub>2</sub> "	23 <sup>1</sup> / <sub>4</sub> "	<b>TS2ARCHBR</b>	\$456

### Holder



Standard Includes		Required to Specify
▶ Need help? Product details, page 28	<ul style="list-style-type: none"> <li>Holder: paint</li> <li>Attachment hardware for wall or arch mount</li> </ul>	1 Style number 2 Paint color number for Holder ▶ See <i>Surface Materials</i> , page 64.

Specification Information				
Dimensions			Style Number	U.S. Price
D	W	H		
3"	26 <sup>7</sup> / <sub>8</sub> "	3"	<b>TS2HOLDER</b>	\$185

### Planter



Standard Includes		Required to Specify
▶ Need help? Product details, page 28	<ul style="list-style-type: none"> <li>Planter: black</li> </ul>	Style number

  

Specification Information				
Dimensions			Style Number	U.S. Price
D	W	H		
27 <sup>1</sup> / <sub>8</sub> "	26 <sup>3</sup> / <sub>4</sub> "	27 <sup>1</sup> / <sub>8</sub> "	<b>TS2PLANTER</b>	\$83

 **For Canadian Pricing**  
 Multiply U.S. Price by the Canadian price factor.  
 ▶ See page 1 for details.

# Rumble Seat and Hoodie

## Rumble Seat

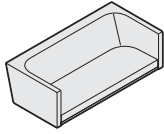

Tip: Order Rumble Seat with exposed bracket when you plan to install a Hoodie.

Standard Includes	Required to Specify
<ul style="list-style-type: none"> <li>Need help? Product details, page 32</li> <li>Fully upholstered lounge: Connect fabric</li> <li>Lounge shipped fully assembled</li> </ul>	<ul style="list-style-type: none"> <li>1 Style number</li> <li>2 Connect fabric color number for upholstery</li> <li>3 Options, if selected (see below)</li> <li>▶ See <i>Surface Materials</i>, page 64.</li> </ul>

Options	U.S. Price	Required to Specify
<b>Surface Materials</b> <ul style="list-style-type: none"> <li>Upholstery</li> <li>Fabric price group 1</li> </ul>	No cost	Specify fabric color number.
<b>Supports</b> <ul style="list-style-type: none"> <li>Table frame attachment bracket</li> <li>Freestanding legs</li> </ul>	+\$300 +\$843	Specify paint color number. Specify paint color number.

Specification Information				
Dimensions			Style Number	U.S. Base Price
D	W	H		
28"	58"	16"	TS3RS	\$2410

Tip: Rumble Seat fits with 60"W Bivi Table or Table for Two. Rumble Seat does not fit with 48"W Bivi Table or Bivi Table for Two.

Rumble Seat				
28"	58"	16"	TS3RS	\$2410

Rumble Seat with Exposed Bracket				
28"	58"	16"	TS3RSBKT	\$2410

## Rumble Seat Supports

Standard Includes	Required to Specify
<ul style="list-style-type: none"> <li>Need help? Product details, page 32</li> <li>Freestanding legs: painted steel</li> <li>Table frame attachment brackets: painted steel</li> <li>Leveling glides</li> <li>Attachment hardware</li> <li>Shipped ready to assemble</li> </ul>	<ul style="list-style-type: none"> <li>1 Style number</li> <li>2 Color number for support</li> <li>▶ See <i>Surface Materials</i>, page 64.</li> </ul>

Specification Information				
Dimensions			Style Number	U.S. Price
D	W	H		
28"	58"	12"	TS3RSL2	\$847

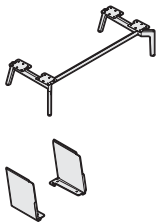

Freestanding Legs				
28"	58"	12"	TS3RSL2	\$847

Table Frame Attachment Brackets				
5 1/2"	17"	16 5/8"	TS3RSTA	\$300

**Hoodie**

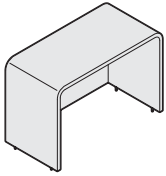

Standard Includes	Required to Specify
-------------------	---------------------

- |   |  |   |
|---|--|---|
| <ul style="list-style-type: none"> <li>▶ Need help? Product details, page 32</li> </ul> | <ul style="list-style-type: none"> <li>• Fully upholstered top and sides</li> <li>• Mesh back panel: T615 Sultry Smoke</li> <li>• Shipped ready to assemble</li> </ul> | <ul style="list-style-type: none"> <li>1 Style number</li> <li>2 Connect fabric color number for top and sides</li> <li>▶ See <i>Surface Materials</i>, page 64.</li> </ul> |
|---|--|---|

Specification Information				
• Dimensions			• Style	• U.S.
D	W	H	Number	Price

28"	58"	38 <sup>1</sup> / <sub>8</sub> "	<b>TS3RSH</b>	\$1393
:	:	:	:	:

**Hoodie**

28"	58"	38 <sup>1</sup> / <sub>8</sub> "	<b>TS3RSH</b>	\$1393
:	:	:	:	:



**For Canadian Pricing**

Multiply U.S. Price by the Canadian price factor.

▶ See page 1 for details.

## Half-Round Table Top



Tip: Half-round table tops require assembly.

Tip: Half-round table tops will not work with a stand alone 48"W Bivi Table for Two.

Standard Includes		Required to Specify
<ul style="list-style-type: none"> <li>▶ Need help? Product details, page 34</li> </ul>	<ul style="list-style-type: none"> <li>• 1/2"-thick table top: Low-Pressure Laminate</li> <li>• Edge band: default color to match laminate</li> <li>• Attachment brackets: paint</li> </ul>	<ol style="list-style-type: none"> <li>1 Style number</li> <li>2 Low-Pressure Laminate color number for table top</li> <li>3 Paint color number for attachment brackets</li> </ol> <ul style="list-style-type: none"> <li>▶ See <i>Surface Materials</i>, page 64.</li> </ul>

Specification Information				
Dimensions			Style Number	U.S. Price
D	W	H		
27"	60"		<b>TS2RW</b>	\$476

## Table Top

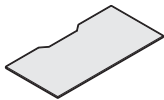

Standard Includes		Required to Specify
<ul style="list-style-type: none"> <li>▶ Need help? Product details, page 34</li> </ul>	<ul style="list-style-type: none"> <li>• 1/2"-thick table top: Low-Pressure Laminate</li> <li>• Edge band: default color to match laminate</li> <li>• Attachment brackets: paint</li> </ul>	<ol style="list-style-type: none"> <li>1 Style number</li> <li>2 Low-Pressure Laminate color number for table top</li> <li>3 Paint color number for attachment brackets</li> </ol> <ul style="list-style-type: none"> <li>▶ See <i>Surface Materials</i>, page 64.</li> </ul>

Specification Information				
Dimensions			Style Number	U.S. Price
D	W	H		
28 1/2"	46 1/2"	2"	<b>TS2RPFWS48</b>	\$375
28 1/2"	58 1/2"	2"	<b>TS2RPFWS</b>	\$389

## Table Top with Back Pocket

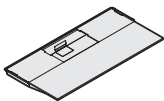

Standard Includes		Required to Specify
<ul style="list-style-type: none"> <li>▶ Need help? Product details, page 34</li> </ul>	<ul style="list-style-type: none"> <li>• 1/2"-thick table top: Low-Pressure Laminate</li> <li>• Edge band: default color to match laminate</li> <li>• Back pocket: paint</li> <li>• Two pocket covers: Low-Pressure Laminate</li> <li>• Attachment brackets: paint</li> </ul>	<ol style="list-style-type: none"> <li>1 Style number</li> <li>2 Low-Pressure Laminate color number for table top and pocket covers</li> <li>3 Paint color number for attachment brackets and back pocket</li> </ol> <ul style="list-style-type: none"> <li>▶ See <i>Surface Materials</i>, page 64.</li> </ul>

Specification Information				
Dimensions			Style Number	U.S. Price
D	W	H		
28 1/2"	58 1/2"	4 1/2"	<b>TS2RPSWS</b>	\$498



**For Canadian Pricing**  
 Multiply U.S. Price by the Canadian price factor.  
 ▶ See page 1 for details.

### Pocket Cover



Standard Includes		Required to Specify
<ul style="list-style-type: none"> <li>▶ Need help? Product details, page 34</li> </ul>	<ul style="list-style-type: none"> <li>• 1/4"-thick Pocket Cover: Low-Pressure Laminate</li> <li>• Edge band: default color to match laminate</li> </ul>	<ul style="list-style-type: none"> <li>1 Style number</li> <li>2 Laminate color number for Pocket Cover</li> <li>▶ See <i>Surface Materials</i>, page 64.</li> </ul>

Specification Information				
Dimensions			Style Number	U.S. Price
D	W	H		
123/4"	191/4"	1/2"	<b>TS2RPTC</b>	\$94

### Cable Trough

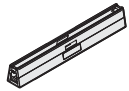

Standard Includes		Required to Specify
<ul style="list-style-type: none"> <li>▶ Need help? Product details, page 18</li> </ul>	<ul style="list-style-type: none"> <li>• Cable trough: painted steel</li> <li>• Hardware to install to Bivi Legs</li> </ul>	<ul style="list-style-type: none"> <li>1 Style number</li> <li>2 Paint color number for cable trough</li> <li>▶ See <i>Surface Materials</i>, page 64.</li> </ul>

Related Products	
<ul style="list-style-type: none"> <li>• Rumble Seat</li> <li>• Bivi Tables</li> </ul>	<ul style="list-style-type: none"> <li>▶ Page 55</li> <li>▶ Page 37</li> </ul>

Specification Information					
Dimensions				Style Number	U.S. Price
D at top	D at bottom	W	H		
4"	65/8"	46"	8"	<b>TS2RPCT48</b>	\$519
4"	65/8"	58"	8"	<b>TS2RPCT</b>	\$574

### Leg



Tip: Leg requires assembly.

Standard Includes		Required to Specify
<ul style="list-style-type: none"> <li>▶ Need help? Product details, page 34</li> </ul>	<ul style="list-style-type: none"> <li>• Leg: paint</li> </ul>	<ul style="list-style-type: none"> <li>1 Style number</li> <li>2 Paint color number for leg</li> <li>▶ See <i>Surface Materials</i>, page 64.</li> </ul>

Specification Information				
Dimensions			Style Number	U.S. Price
D	W	H		
2"	421/4"	281/2"	<b>TS2RPBSL</b>	\$421

 **For Canadian Pricing**  
 Multiply U.S. Price by the Canadian price factor.  
 ▶ See page 1 for details.

## Top Shelf



Tip: Three shelves can fit across one Bivi table.

Standard Includes	Required to Specify
<ul style="list-style-type: none"> <li>▶ Need help? Product details, page 34</li> <li>• Top shelf: paint</li> </ul>	<ul style="list-style-type: none"> <li>1 Style number</li> <li>2 Paint color number for top shelf</li> <li>▶ See <i>Surface Materials</i>, page 64.</li> </ul>

Specification Information				
• Dimensions			• Style	• U.S.
D	W	H	Number	Price
8 1/2"	19"	8"	<b>TS2ACMS</b>	\$206

## Bottom Shelf



Tip: Bottom shelf hooks into Bivi leg.

Standard Includes	Required to Specify
<ul style="list-style-type: none"> <li>▶ Need help? Product details, page 34</li> <li>• Bottom Shelf: paint</li> </ul>	<ul style="list-style-type: none"> <li>1 Style number</li> <li>2 Paint color number for Bottom Shelf</li> <li>▶ See <i>Surface Materials</i>, page 64.</li> </ul>

Specification Information				
• Dimensions			• Style	• U.S.
D	W	H	Number	Price
8 1/2"	18 1/2"	17"	<b>TS2ACTH</b>	\$198

## Hook



Tip: Hook attaches to a Bivi leg and an Arch.

Standard Includes	Required to Specify
<ul style="list-style-type: none"> <li>▶ Need help? Product details, page 34</li> <li>• Hook: paint</li> </ul>	<ul style="list-style-type: none"> <li>1 Style number</li> <li>2 Paint color number for Hook</li> <li>▶ See <i>Surface Materials</i>, page 64.</li> </ul>

Specification Information				
• Dimensions			• Style	• U.S.
D	W	H	Number	Price
1 3/4"	2"	1"	<b>TS2ACMH2</b>	\$52

### Package of Two

1 3/4"	2"	1"	<b>TS2ACMH2</b>	\$52
--------	----	----	-----------------	------

### Package of Four

1 3/4"	2"	1"	<b>TS2ACMH4</b>	\$83
--------	----	----	-----------------	------



**For Canadian Pricing**  
 Multiply U.S. Price by the Canadian price factor.  
 ▶ See page 1 for details.

## Screen



*Tip: Screens are not a markerboard. Writing will not erase from the painted surface.*

Standard Includes	Required to Specify
<ul style="list-style-type: none"> <li>▶ Need help? Product details, page 28</li> <li>• Steel screen: paint</li> <li>• Trough PUCKs: plastic</li> <li>• Ships ready to assemble</li> </ul>	<ul style="list-style-type: none"> <li>1 Style number</li> <li>2 Paint color number for steel screen</li> <li>3 Plastic color number for trough PUCKs</li> <li>▶ See <i>Surface Materials</i>, page 64.</li> </ul>

Related Products
<ul style="list-style-type: none"> <li>• Bivi Tables <span style="float: right;">▶ Page 37</span></li> </ul>

Specification Information				
• Dimensions			• Style	• U.S.
D	W	H	Number	Price
3 1/2"	30"	14 1/4"	TS2SCREEN	\$206

## Organizer



Standard Includes	Required to Specify
<ul style="list-style-type: none"> <li>▶ Need help? Product details, page 28</li> <li>• Organizer: painted steel</li> </ul>	<ul style="list-style-type: none"> <li>1 Style number</li> <li>2 Paint color number for Organizer</li> <li>▶ See <i>Surface Materials</i>, page 64.</li> </ul>

Related Products
<ul style="list-style-type: none"> <li>• Side Storage <span style="float: right;">▶ Page 52</span></li> </ul>

Specification Information				
• Dimensions			• Style	• U.S.
D	W	H	Number	Price
11 1/2"	14 1/8"	7"	TS2ORGANIZE	\$164



**For Canadian Pricing**  
 Multiply U.S. Price by the Canadian price factor.  
 ▶ See page 1 for details.

### Trough End Cover



Standard Includes	Required to Specify
-------------------	---------------------

- Trough end cover set of two: paint

- 1 Style number
- 2 Paint color number for trough end cover
- ▶ See *Surface Materials*, page 64.

Specification Information				
• Dimensions			• Style	• U.S.
D	W	H	Number	Price

7/8"	4"	45/8"	<b>TS2CTEC</b>	\$48
------	----	-------	----------------	------

### Trough Floor Cover



Standard Includes	Required to Specify
-------------------	---------------------

- Trough floor cover set of two: paint
- Attachment hardware

- 1 Style number
- 2 Paint color number for trough floor cover
- ▶ See *Surface Materials*, page 64.

Specification Information				
• Dimensions			• Style	• U.S.
D	W	H	Number	Price

2 1/2"	8"		<b>TS2CTFC</b>	\$55
--------	----	--	----------------	------

### Leg Cover



Standard Includes	Required to Specify
-------------------	---------------------

- Trough leg cover set of two: paint

- 1 Style number
- 2 Paint color number for trough leg cover
- ▶ See *Surface Materials*, page 64.

Specification Information				
• Dimensions			• Style	• U.S.
D	W	H	Number	Price

7/8"	4"	45/8"	<b>TS2LEGCVR</b>	\$115
------	----	-------	------------------	-------



**For Canadian Pricing**  
 Multiply U.S. Price by the Canadian price factor.  
 ▶ See page 1 for details.

# Eyesite

## Eyesite Single Display Support with Extended Crank Adjustment Column



Tip: Eyesite monitor arms with Bivi brackets can be installed at six different locations on the cable trough.

Tip: Supports displays up to 21 lb and has a functional focal length of 16".

Standard Includes				Required to Specify
<ul style="list-style-type: none"> <li>Monitor arm: 4799 Platinum</li> <li>Extended crank adjustment column with 12<sup>1</sup>/<sub>2</sub>" vertical height adjustment</li> </ul>				Style number
Specification Information				
Dimensions			Style Number	U.S. Price
D	W	H		
6 <sup>5</sup> / <sub>8</sub> "	11 <sup>5</sup> / <sub>8</sub> "	20"	<b>FPAEC1BIVI</b>	\$486

## Eyesite Dual Display Supports with Extended Crank Adjustment Column

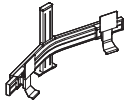

Tip: Supports two displays up to 24" or 25 lb each and has a functional focal length of 13".

Standard Includes				Required to Specify
<ul style="list-style-type: none"> <li>Monitor arm: 4799 Platinum</li> <li>Extended crank adjustment column with 12<sup>1</sup>/<sub>2</sub>" vertical height adjustment</li> </ul>				Style number
Specification Information				
Dimensions			Style Number	U.S. Price
D	W	H		
8 <sup>1</sup> / <sub>2</sub> "	31"	20"	<b>FPAEC2BIVI</b>	\$763

## Eyesite Flat Panel Monitor Arm with Single Laptop Support and Extended Crank Adjustment Column

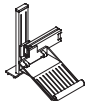

Tip: Eyesite monitor arms with Bivi brackets can be installed at six different locations on the cable trough.

Tip: Functional focal length is 16".

Tip: Not recommended for use with docking stations.

Standard Includes				Required to Specify
<ul style="list-style-type: none"> <li>Laptop support arm: 4799 Platinum</li> <li>Extended crank adjustment column with 12<sup>1</sup>/<sub>2</sub>" vertical height adjustment</li> </ul>				Style number
Specification Information				
Dimensions			Style Number	U.S. Price
D	W	H		
16"	11 <sup>5</sup> / <sub>8</sub> "	19 <sup>7</sup> / <sub>8</sub> "	<b>FPAELC1BIVI</b>	\$513

## Eyesite Flat Panel Monitor Arm with Dual Laptop Supports and Extended Crank Adjustment Column

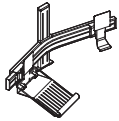

Tip: Eyesite dual laptop support is for use with monitor up to 24" screen and 25 lb.

Tip: Eyesite flat panel monitor arms with laptop supports are not recommended for use with docking station.

Tip: Monitor cables can connect to the rear of the monitor near the VESA plate will not fit properly on Eyesite monitor arm.

Tip: Bivi bracket to be used with Eyesite single support, dual display support, and dual laptop support with extended crank adjustment columns only.

Standard Includes	Required to Specify
<ul style="list-style-type: none"> <li>Laptop support monitor arm: 4799 Platinum</li> <li>Extended crank adjustment column with 12<sup>1</sup>/<sub>2</sub>" vertical height adjustment</li> </ul>	1 Style number 2 Options, if selected (see below)

Options	U.S. Price	Required to Specify
<b>Bracket</b>		
<ul style="list-style-type: none"> <li>Without pivot</li> <li>With pivot</li> </ul>	No cost +\$18	Specify <i>without pivot</i> . Specify <i>with pivot</i> .

Specification Information				
Dimensions			Style Number	U.S. Base Price
D	W	H		
17"	31"	19 <sup>7</sup> / <sub>8</sub> "	<b>FPAELC2BIVI</b>	\$813

## Bivi Bracket



Tip: If you have any existing Eyesite monitor arms, you can order a Bivi bracket to modify it to work with Bivi Tables.

Standard Includes	Required to Specify
<ul style="list-style-type: none"> <li>Bivi mounting bracket: 4799 Platinum</li> </ul>	Style number

Specification Information				
Dimensions			Style Number	U.S. Price
D	W	H		
3"	4"	1/4"	<b>FPCBIVI</b>	\$124



**For Canadian Pricing**  
 Multiply U.S. Price by the Canadian price factor.  
 ▶ See page 1 for details.

# Surface Materials

► For Surface Materials matrices for all product lines, see page 305.

## Paint

### Steelcase Surfaces

Applies to:

- Cable trough
- Bivi legs
- Trunk shelves
- Back pocket
- Power kit
- Attachment bracket
- Top shelf
- Bottom shelf
- Arch
- Table frame attachment brackets
- Trough end cover
- Trough floor cover
- Leg cover
- 4799 Platinum Metallic
- 7241 Arctic White
- 7246 Midnight Metallic

Applies to:

- Bike hook
- Board rack
- Holder
- Hook
- Screen
- Organizer
- Side storage
- Freestanding legs
- 4140 Arctic White
- 4799 Platinum Metallic
- 7246 Midnight Metallic

Applies to:

- Eyesight monitor arms
- 4799 Platinum Metallic

Applies to:

- Bivi bracket
- 4799 Platinum Metallic

## Laminate

### Steelcase Surfaces

#### Low-Pressure Laminate

Applies to:

- Bivi table tops
- Depot
- Trunk
- Pocket covers
- 25L5 Virginia Walnut LPL
- 25L6 Blackwood LPL
- 25L8 Clear Walnut LPL
- 25L9 Warm Oak LPL **E**
- 2L30 Arctic White LPL

*Tip: Established finishes are available for delivery in 15 business days.*

**E** = Established

## Plastic

Applies to:

- Screen PUCKs
- 6009 Arctic White
- 6249 Platinum Solid
- 6695 Midnight

## Upholstery

### Steelcase Surfaces

Applies to:

- Rumble Seat
- Cogent: Connect

Applies to:

- Hoodie top and sides
- 5S25 Cogent: Connect Graphite
- 5S26 Cogent: Connect Licorice

Applies to:

- Canopy
- 5VD0 Bivi Canopy Fabric

## Mesh

Applies to:

- Hoodie back
- T615 Sultry Smoke

# Tour Workspace

Tip: Established finishes are available for delivery in 15 business days.

**E** = Established

## Statement of Line **66**

### Product Details

Counter and Countertop Facts	<b>67</b>
Electrical Facts	<b>68</b>
Worksurface-Height Power and Communication Accessories Facts	<b>76</b>
Bench Component Facts	<b>78</b>
Worksurface and Shelf Facts	<b>79</b>
Worksurface Supports Facts	<b>80</b>
Screen and Screen Connector Facts	<b>82</b>
Freestanding Screen Stability Rules	<b>85</b>
HV Cabinet Facts	<b>86</b>
Bookcase Facts	<b>87</b>
My File Facts	<b>88</b>
Pile File Facts	<b>89</b>

### Specifying

Counters and Countertops	<b>90</b>
Electrical Components	<b>92</b>
Worksurface-Height Power and Communication Accessories	<b>100</b>
Bench Components	<b>105</b>
SOTO Tour Rails	<b>106</b>
Worksurfaces	<b>107</b>
Worksurface Supports	<b>112</b>
Shelves	<b>115</b>
Modesty Panels	<b>116</b>
Screens and Screen Connectors	<b>117</b>
HV Cabinets	<b>119</b>
Bookcases	<b>121</b>
My File	<b>122</b>
Pile File	<b>124</b>
Magnetic Markerboards and Tackboards	<b>125</b>
Task Lights	<b>126</b>
SOTO	<b>127</b>

## Surface Materials **128**

# Statement of Line

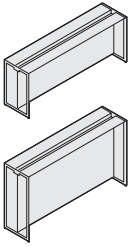

**Counters**  
▶ Page 90

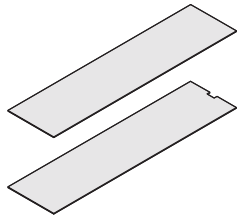

**Countertops**  
▶ Page 91

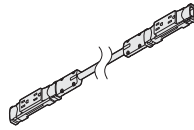

**Electrical Components**  
▶ Pages 92–99

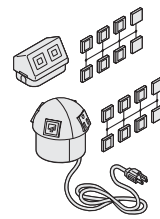

**Power and Communication Accessories**  
▶ Pages 100–104

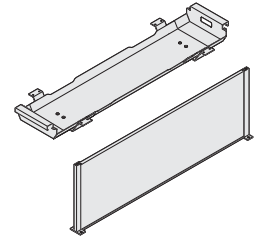

**Bench Trough and Screen**  
▶ Page 105

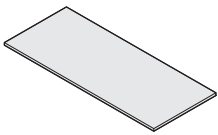

**Straight Worksurfaces**  
▶ Page 107

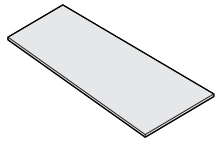

**Tapered Worksurfaces**  
▶ Page 108

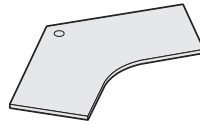

**120° Corner Worksurfaces**  
▶ Page 109

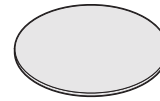

**Round Worksurfaces**  
▶ Page 110

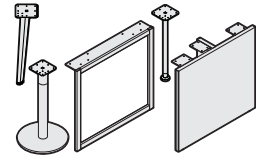

**Worksurface Supports**  
▶ Pages 112–114

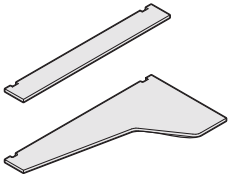

**Shelves**  
▶ Page 115

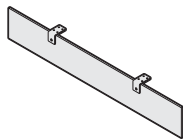

**Modesty Panels**  
▶ Page 116

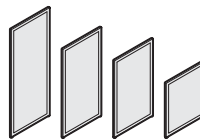

**Screens and Screen Connectors**  
▶ Pages 117–118

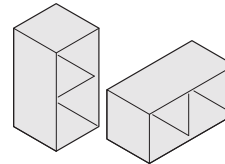

**HV Cabinet**  
▶ Pages 119–120

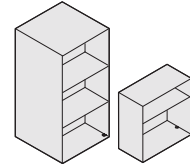

**Bookcases**  
▶ Page 121

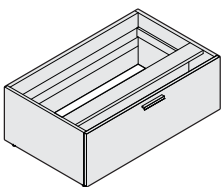

**My File**  
▶ Pages 122–123

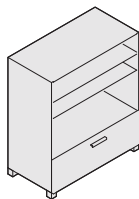

**Pile File**  
▶ Page 124

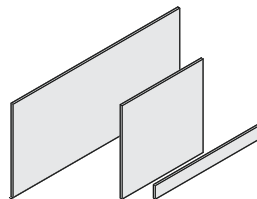

**Magnetic Markerboards and Tackboards**  
▶ Page 125



**Details Worktools**  
▶ Page 265

# Counter and Countertop Facts

**Counters** are constructed with a painted steel horizontal component and clear anodized aluminum end supports. Counters are 30"H or 42"H x 18"D x 72"W. A laminate infill on the counter centerline provides stability and can be optioned in painted steel. Counters ship knocked down in five pieces.

► Specifying, pages 90–91

**Directional laminate**

runs horizontal on the counter center infill, and runs vertical on the optional frame support infills.

**Laminate countertops** provide a finished appearance to the top of the counter. Countertops are not necessary where a HV cabinet is used. Countertops are available in four sizes, 18"D x 18"W, 36"W, 54"W, or 72"W. Countertops are also available with a notch that facilitates access to data components.

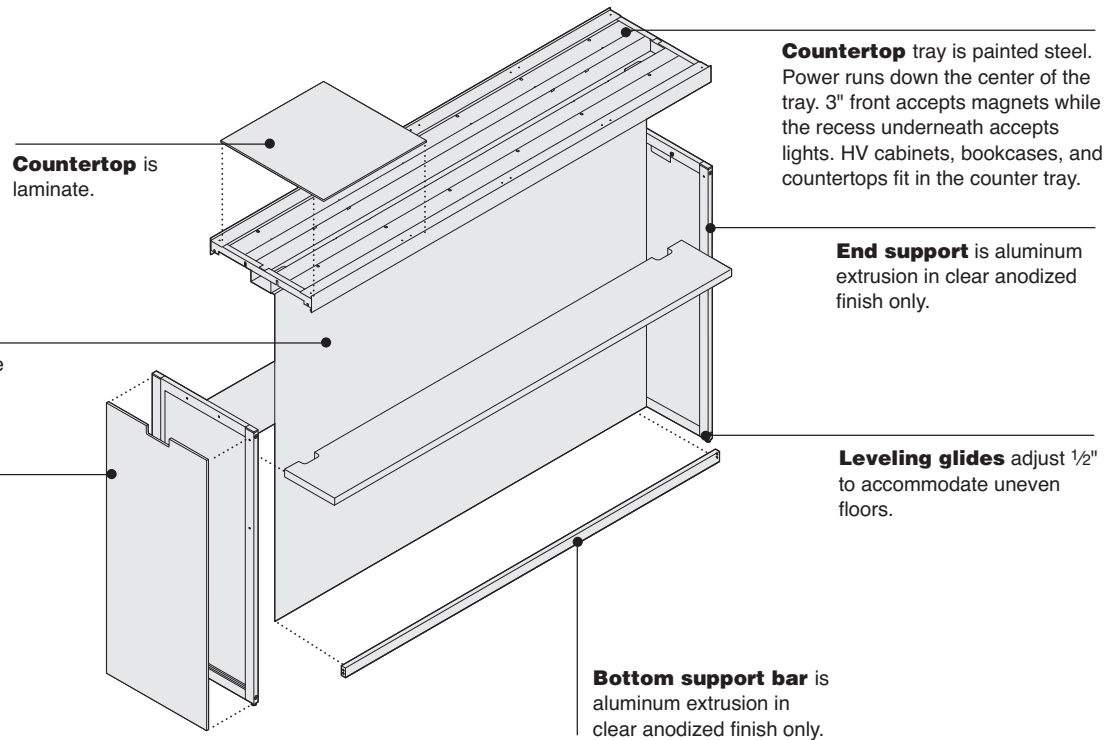

**Counters** attach to each other when oriented in a straight line and are the same height. Counter-to-counter attachment hardware is included.

**Recess underneath the counter** can accommodate an under-shelf task light.

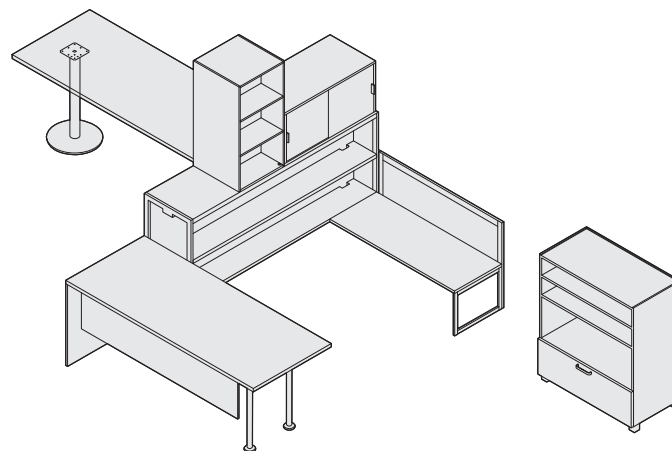

# Electrical Facts

## Powerways

**Factory-installed powerway** is a one-circuit system. Multiple circuits can be utilized depending on which building circuit is accessed.

**A one-, two-, or four-circuit** powerway is available for field installation.

**Optional powerway** has four duplex receptacles (two on each end) that are accessible from underneath top of counter.

**All powerways and base power-ins** are PVC-free.

**Base power-in** can connect to either end of any powerway, including a counter in the middle of a run of connected counters.

► Specifying, page 92

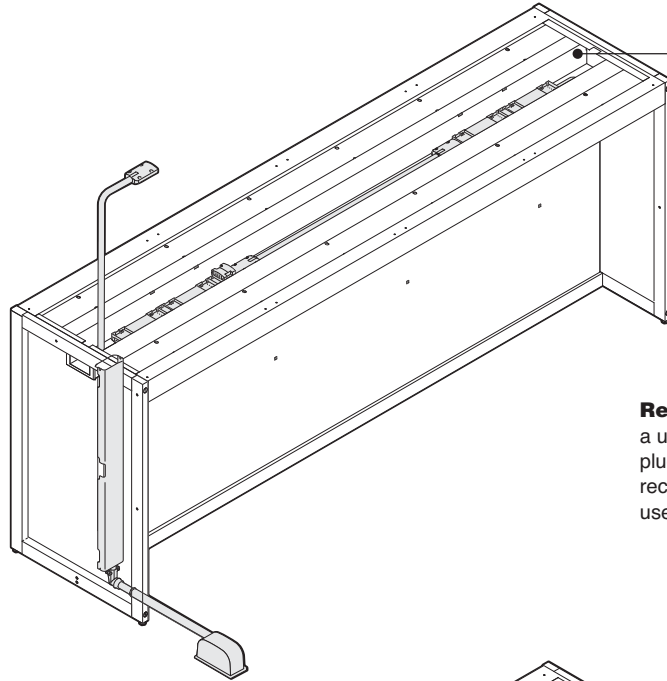

**Data cords** can be managed in the top of the counter which holds a quantity of 42 CAT5e or 32 CAT6 cables.

**Receptacle base power-in** allows a user to power a counter with a simple plug to a 20-amp building receptacle. A receptacle base power-in can only be used with a one-circuit powerway.

**A hard-wired base power-in** provides traditional access to the building power source. This can be used for either one-, two-, or four-circuit powerways.

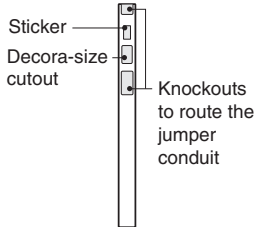

**There are three knockouts** in the 30" and 42" vertical wire managers, style numbers TSTECC30 and TSTEC42. The first and third are available to route Tour power jumpers when used and the second is standard Decora-size to fit data ports, approximately 1¾"W x 2⅝"H.

**A quantity of 24 CAT5e or 18 CAT6 cables** can be managed down the vertical wire manager.

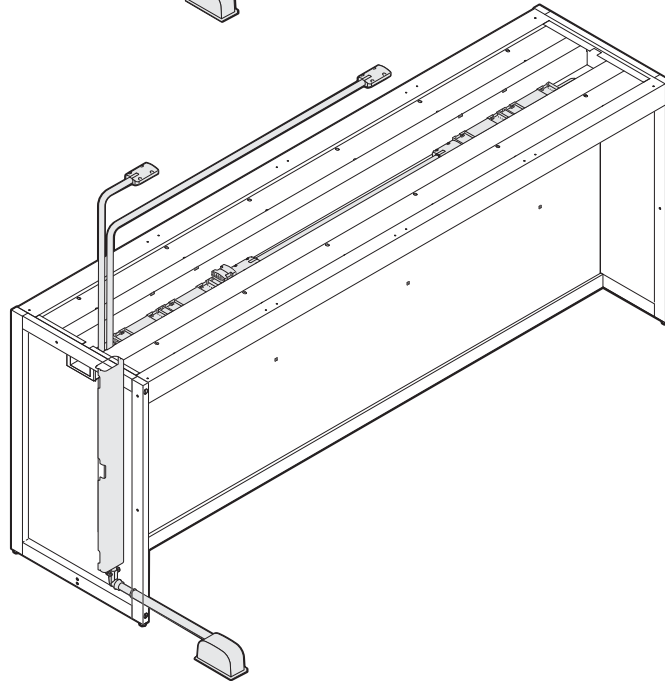

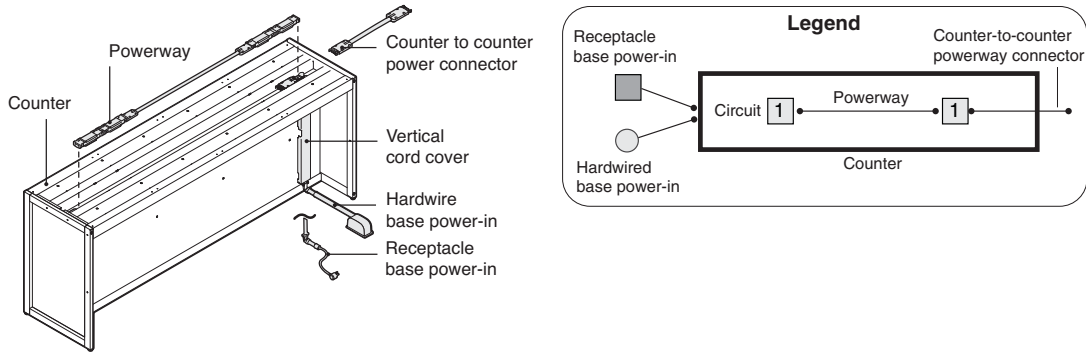

### One-circuit Solution

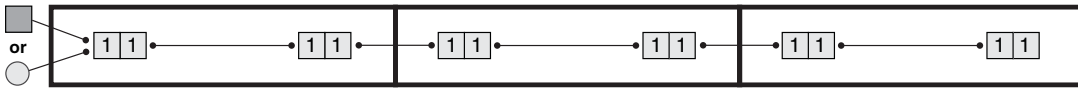

**Notes:**

- Two different base power-in options:
  - One-circuit receptacle base power-in (TSTEPBR130 or TSTEPBR142)
  - Two-circuit hardwired base power-in (TSTEPBT2)
- One-circuit powerway available as factory-installed or field-installed (TSTEP172).
- Counter-to-counter power connector (TSTEP2C) is a two-circuit connector
- Base power-in can be installed on any counter - at middle or end-of-run
- Maximum run is three counters (six users)

### Two-circuit Solution



**Notes:**

- One base power-in option
  - Two-circuit hardwired base power-in (TSTEPBT2)
- Two-circuit powerway (TSTEP272) is field-installed only
- Counter-to-counter power connector (TSTEP2C) is a two-circuit connector
- Base power-in can be installed on any counter - at middle or end-of-run
- Maximum run is six counters (twelve users)

### Four-circuit Solution

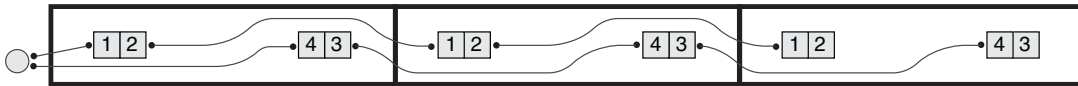

**Notes:**

- One base power-in option
  - Four-circuit hardwired base power-in (TSTEPBT4)
- Four-circuit powerway (TSTEP472) is field-installed only, and includes a Line 1 and Line 2 receptacle, and a Line 3 and Line 4 receptacle.
- Counter-to-counter power connector (TSTEP2C4) is a four-circuit connector.
- Base power-in can be installed on any counter - at middle or end-of-run
- Maximum run is thirteen counters (twenty-six users)

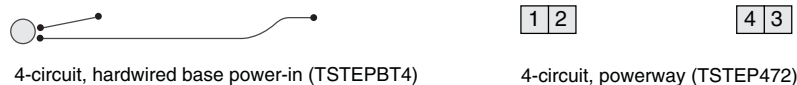

# Electrical Facts

## Counter-to-Counter Connectors

**Counters** must be connected with enclosed attachment brackets.

► Specifying, page 95

**Counters** must be connected to counters of the same height, either 30"H or 42"H.

**Counter-to-counter connectors** are available to route power (1- or 2-circuit or 4-circuit) from one counter to another by using a modular connection.

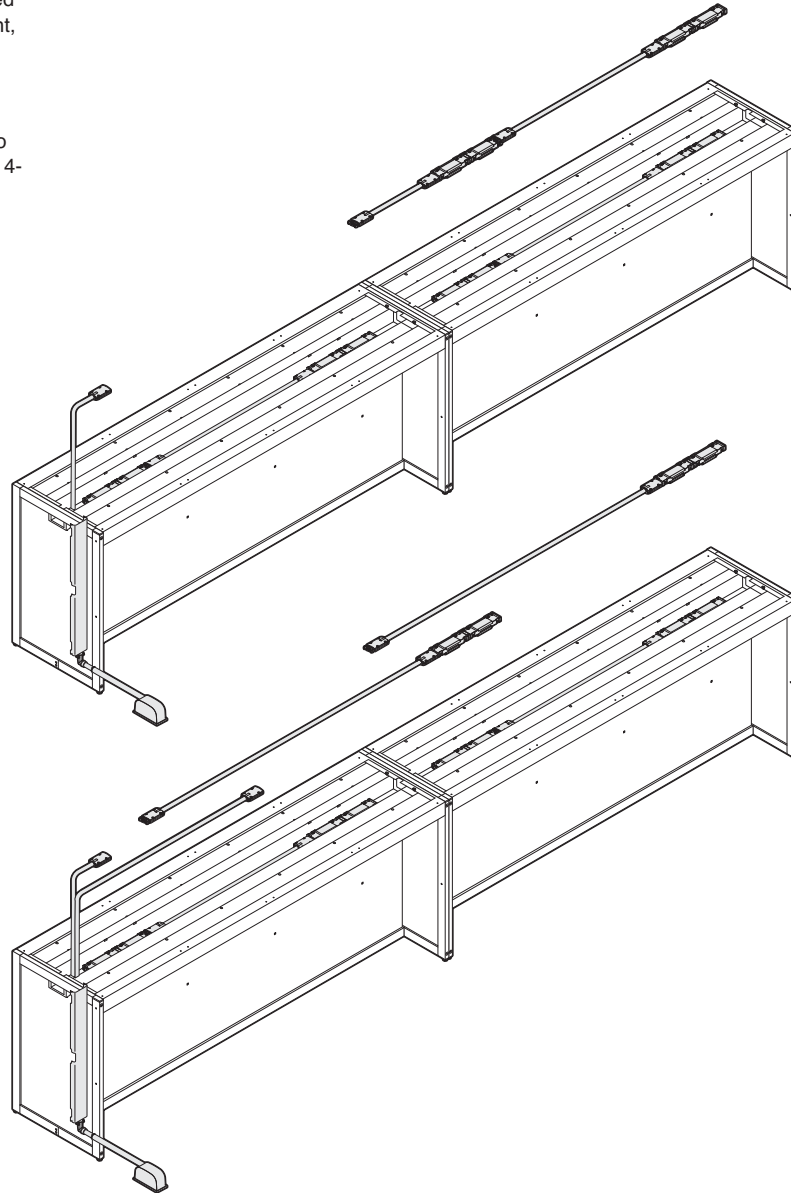

**Data** can be routed from counter-to-counter, and vertically through the vertical cord manager.

**Receptacle base power-in** allows a user to power a counter with a simple plug to a 20-amp building receptacle, and extend 24" outside the counter. A receptacle base power-in can only be used with a one-circuit powerway.

**A hardwired base power-in** provides traditional access to the building power source. This can be used for either one-, two-, or four-circuit powerways.

**San Francisco base power-ins** have 72" outside of counter.

# Electrical Facts

## Counter-to-Counter Power Jumpers

**Power jumpers** move power from one counter to the next counter when they are separated by a worksurface(s).

► Specifying, pages 96-99

**Power jumpers** are used as an alternative solution to a separate base power-in per counter when raised flooring to access power is not available, or not desirable.

### Power Jumper Rules

The following applies to all applications of power jumping:

1. Counters and worksurfaces must be mechanically attached – the worksurfaces must be attached to either a counter, a shelf, or counter end frame. If multiple worksurfaces are used between counters they must also be connected to each other with tie plates.
2. Jumpers must be secured to the worksurface - this is accomplished in two ways:
  - a. Connect jumper every 12" with provided fasteners.
  - b. Encasing jumper in provided horizontal wire manager, which is required, if jumper is routed within 18" of an exposed user edge.
3. In-line jumpers: 2' minimum, and 4' maximum between counters. Side-by-side and benching jumpers: 4' minimum, and 10' maximum between counters.

**There are three types of power "jumpers" depending on your configuration:**

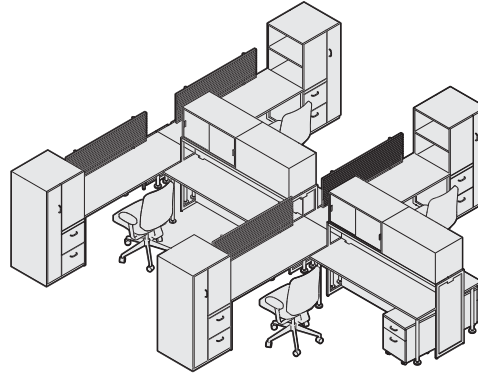

**In-line jumper**—two counters in-line with a worksurface(s) between them, (2' min - 4' max between counters).

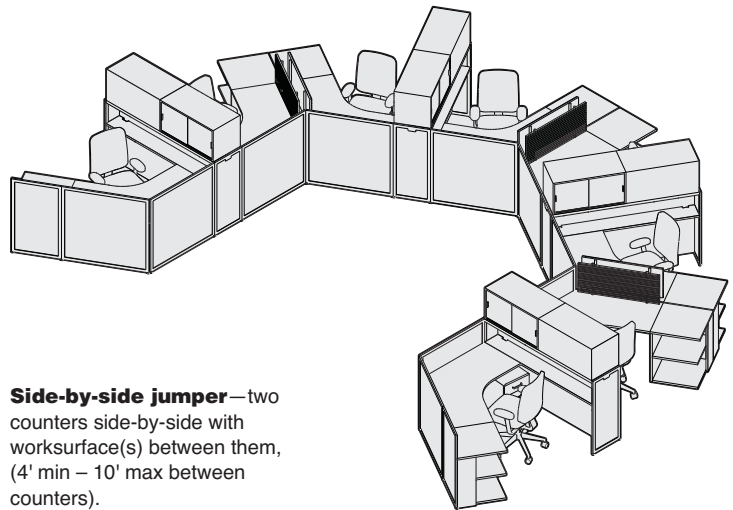

**Side-by-side jumper**—two counters side-by-side with worksurface(s) between them, (4' min – 10' max between counters).

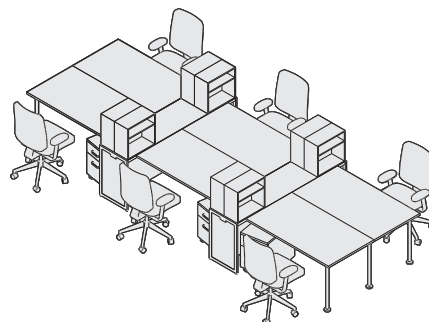

**Benching jumper**—two counters with benching worksurfaces between them, (4' min – 10' max between counters).

# Electrical Facts

## Specifying Power Jumpers

**The style number of the jumper is determined by four pieces of information:**

1. Type of jumper: in-line, side-by-side, or benching.
2. Which power system is selected 1- and 2 -, or 4-circuit.
3. If worksurfaces are at the same height or different height than the counter (change of height).

Determine the answer to the above three questions and select appropriate "routing inches" provided for you in the matrix.

4. Length of worksurface(s) - measure the length of the worksurface or worksurfaces being used between the two counters. This includes shelf inches that are outside the footprint of the counter. Example: A 21" shelf would add 12" to the worksurface length.

The jumper style number length will equal number of routing inches plus the length of your worksurface(s).

Style number required = number of routing inches + number worksurface inches

*Note: If style number length is not available round up to the next length of jumper.*

**Example 1:**

1. In-line jumper
2. 2-circuit power
3. worksurface/counter same height
4. one 24" wide worksurface  
 Style number = routing inches (see matrix) + worksurfaces inches  
 $45" + 24" = 69"$   
 Jumper style number = TSTEP2C069

**Example 2:**

1. Side-by-side jumper
2. 4-circuit power
3. worksurface/counter different heights
4. two 36" wide worksurfaces  
 Style number = routing inches (see matrix) + worksurfaces inches  
 $108" + 72" = 180"$   
 Jumper style number = TSTEP4C180

**Example 3:**

1. Benching jumper
2. 4-circuit power
3. worksurface/counter different heights
4. one 72" wide worksurface  
 Style number = routing inches (see matrix) + worksurfaces inches  
 $135" + 72" = 207"$   
 Jumper style number = TSTEP4C207

**Routing Inches Matrix**

	<b>In-Line Jumper</b>	<b>Side-by-Side Jumper</b>	<b>Benching Jumper</b>
1- and 2-circuit power Same height (worksurface and counter at the same height)	45"	57"	83"
1- and 2-circuit power One change-of-height (worksurface same height as one counter, different height than second counter)	56"	69"	95"
1- and 2-circuit power Two change-of-height (worksurface at different height than both counters)	67"	81"	107"
4-circuit power Same height (worksurface and counter at the same height)	71"	84"	110"
4-circuit power worksurface One change-of-height (worksurface same height as one counter, different height than second counter)	83"	96"	123"
4-circuit power Different Two change-of-height (worksurface at different height than both counters)	95"	108"	135"

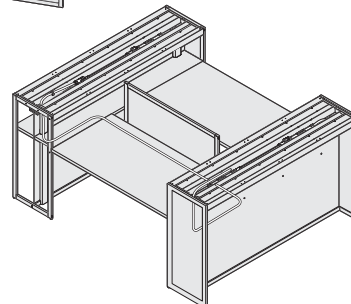
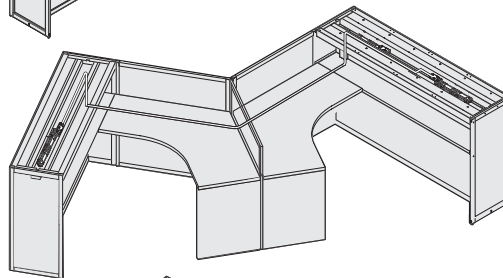
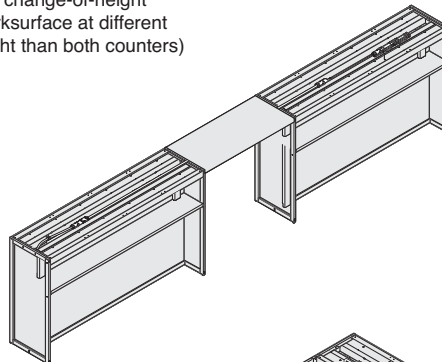

# Electrical Facts

## In-Line Jumpers

**Multiple surfaces** can be used as long as they do not exceed the 4' width max between counters.

► Specifying, pages 96-99

**Open counter end frames** (no end fills) required when power is passing from counter to counter.

**If end fills** are specified field-installed grommet cutouts will be required to use power jumpers.

**Counter end frames on the outside counters** can have end fills.

### Standard Rules

1. Counters and worksurfaces must be connected
2. Jumpers must be secured
3. In-line jumpers: 2' minimum, and 4' maximum between counters

Side-by-side and benching jumpers: 4' minimum, and 10' maximum between counters.

**C-clamps and horizontal cord managers** (TSTECM) are included with power jumpers for installation.

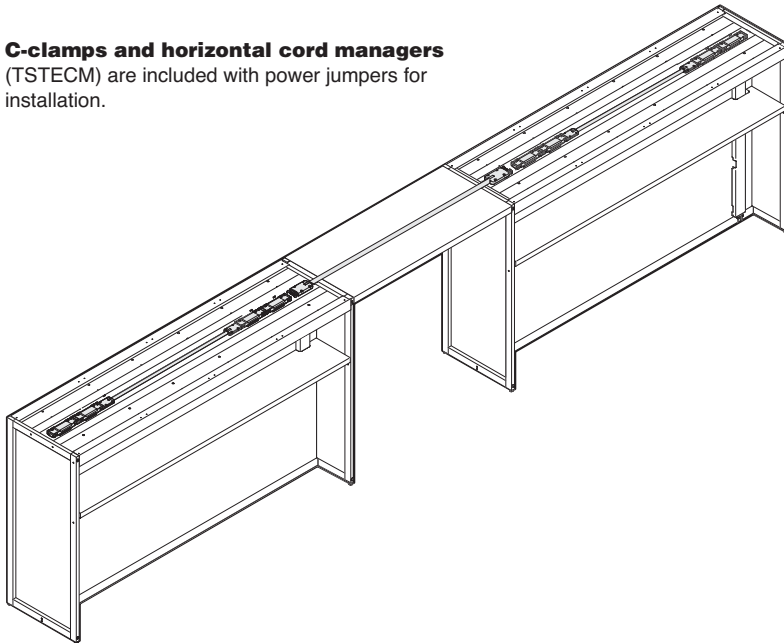

**If counters at the same height** of the worksurface the power is routed through the counter end cap, underneath the worksurface, and through the adjacent counter end cap.

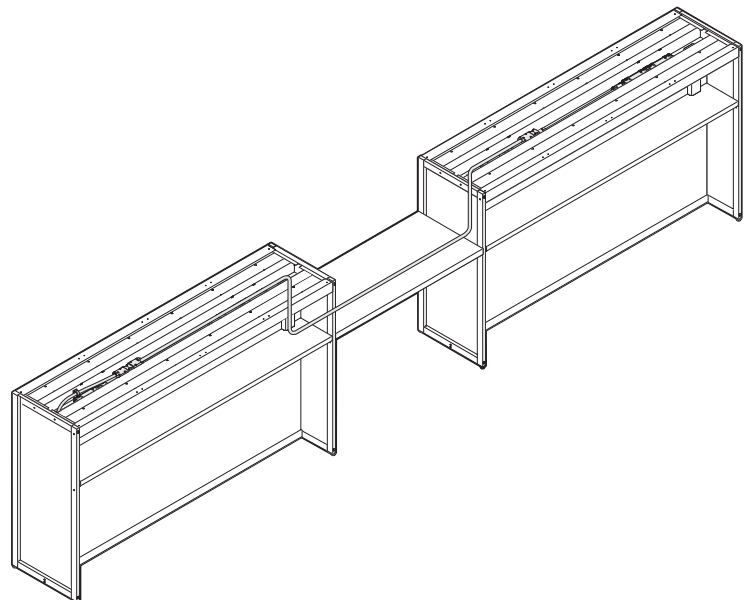

**If counters at different height** than the worksurface the power is routed down the vertical wire manager, underneath the worksurface, and back up to the next counter's vertical wire manager.

# Electrical Facts

## Side-by-Side Jumpers

**Power** is routed 4" from the back edge of the worksurface to position jumper away from the user.

**Multiple surfaces** can be used as long as they do not exceed the 10' width max between counters.

**If screens are used** between worksurfaces field installed grommets will be required to use power jumpers.

► Specifying, pages 96-99

### Standard Rules

1. Counters and worksurfaces must be connected
2. Jumpers must be secured
3. In-line jumpers: 2' minimum, and 4' maximum between counters

Side-by-side and benching jumpers: 4' minimum, and 10' maximum between counter.

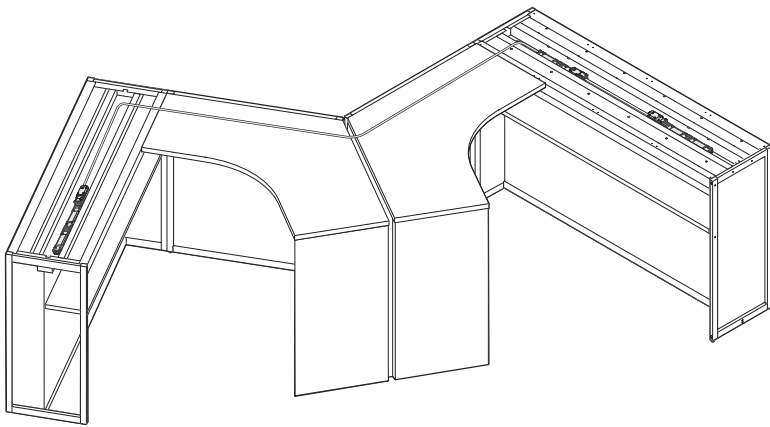

**Counters at the same height of the worksurface**, power is routed out the vertical wire manager, underneath the worksurface, and back in the next counters' vertical wire manager.

**Counters at different height than the worksurface**, power is routed out the vertical wire manager, underneath the worksurface, and back in the next counters' vertical wire manager.

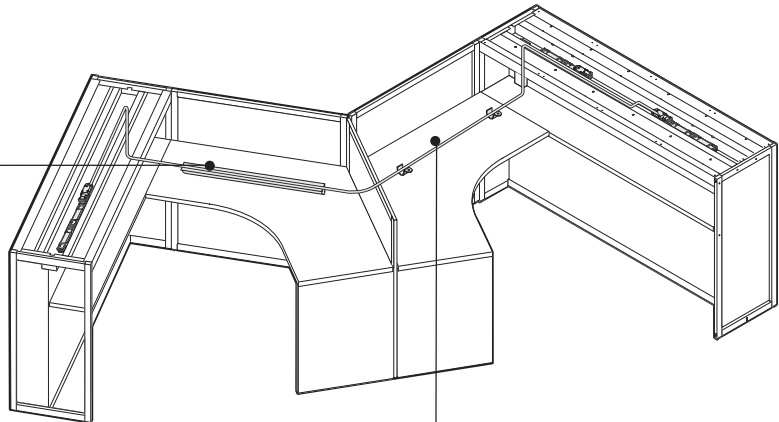

**C-clamps and horizontal cord managers (TSTECM)** are included with power jumpers for installation.

# Electrical Facts

## Benching Jumpers

**Power is routed** 4" from the back edge of the work-surface to position jumper away from the user.

► Specifying, pages 96-99

**Benching jumpers** are called out separately because they require additional jumper length in order to position the jumper a minimum 18" away from the user side.

**Multiple surfaces** can be used as long as they do not exceed the 10' width max between counters.

### Standard Rules

1. Counters and worksurfaces must be connected
2. Jumpers must be secured
3. In-line jumpers: 2' minimum, and 4' maximum between counters

Side-by-side and benching jumpers: 4' minimum, and 10' maximum between counter.

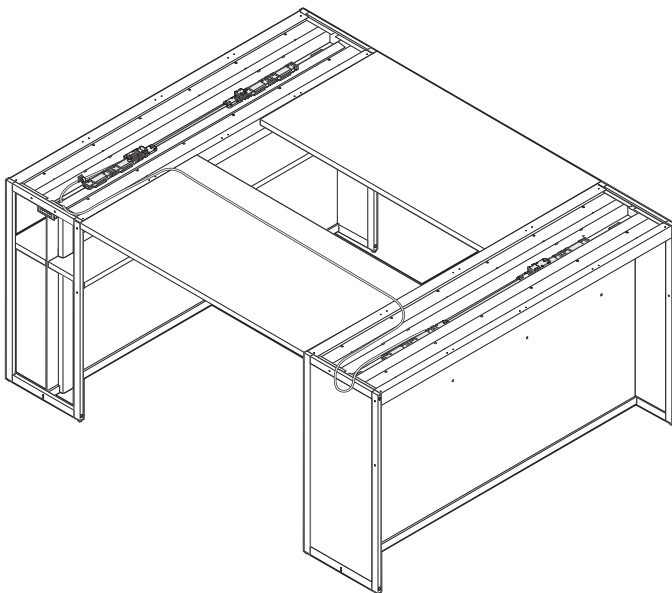

**Counters at the same height of the worksurface**, power is routed down the vertical wire manager, underneath the worksurface, and back up to the next counters' vertical wire manager.

**C-clamps and horizontal cord managers** (TSTECM) are included with power jumpers for installation.

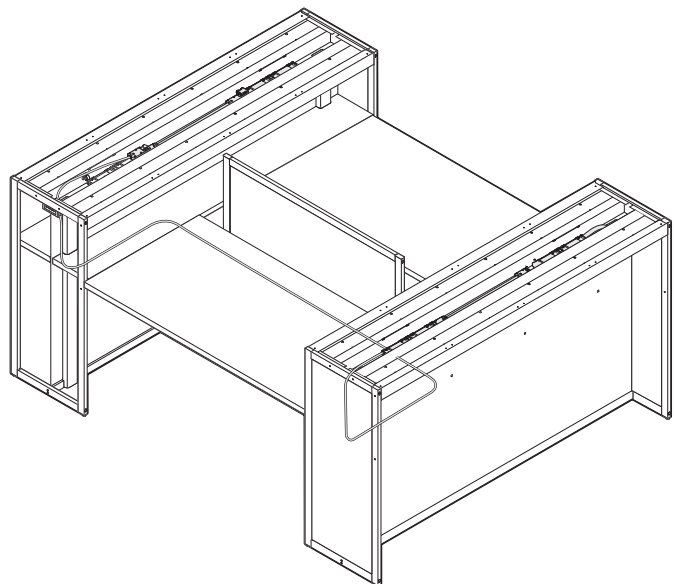

**Counters at different height than the worksurface**, power is routed down the vertical wire manager, underneath the worksurface, and back up to the next counters' vertical wire manager.

# Worksurface-Height Power and Communication Accessories Facts

**Power and data accessories** can mount at any location on worksurfaces and shelves.

**Worksurface mounted accessories** simply clamp onto worksurfaces.

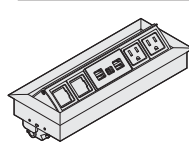

**Grommets for retractable power (TSTERPDWR)** are field installed.  
▶ Page 103



**Vertical cord cover (TSTECC30, TSTECC42)** comes in two height 30" and 42", and is used to conceal and route cables vertically. Data ports can be installed in the vertical cord cover and sits proud. Vertical cord cover grommet (TSTEGC) for data/power cable routing.

*Note: Communication voice/data jacks are customer provided: The manufacturer of the communication port in the vertical cord cover picture is HellermannTyton style number's: FPFURN3 – FW (furniture white), FPFURN3 – BLK (black).*

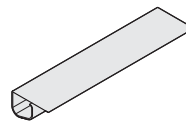

**Horizontal cord manager (TSTECHM)**  
▶ Page 101

**Used to conceal** and route cables underneath the worksurface.

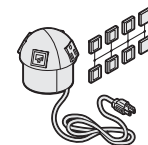

**Worksurface-mounted power and communication sphere (TSTERPDWD)** is field installed for all worksurfaces except 120° worksurfaces.  
▶ Page 101

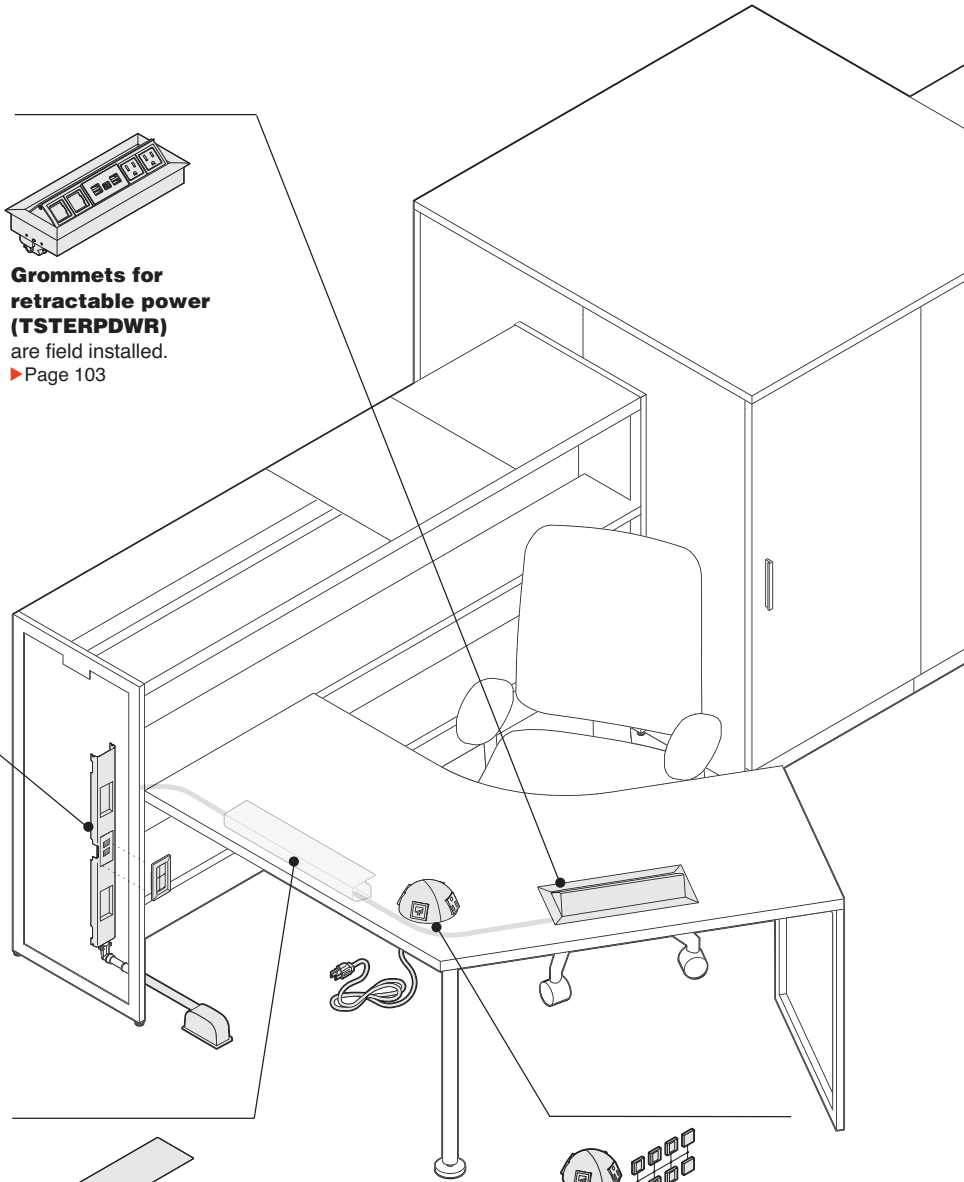

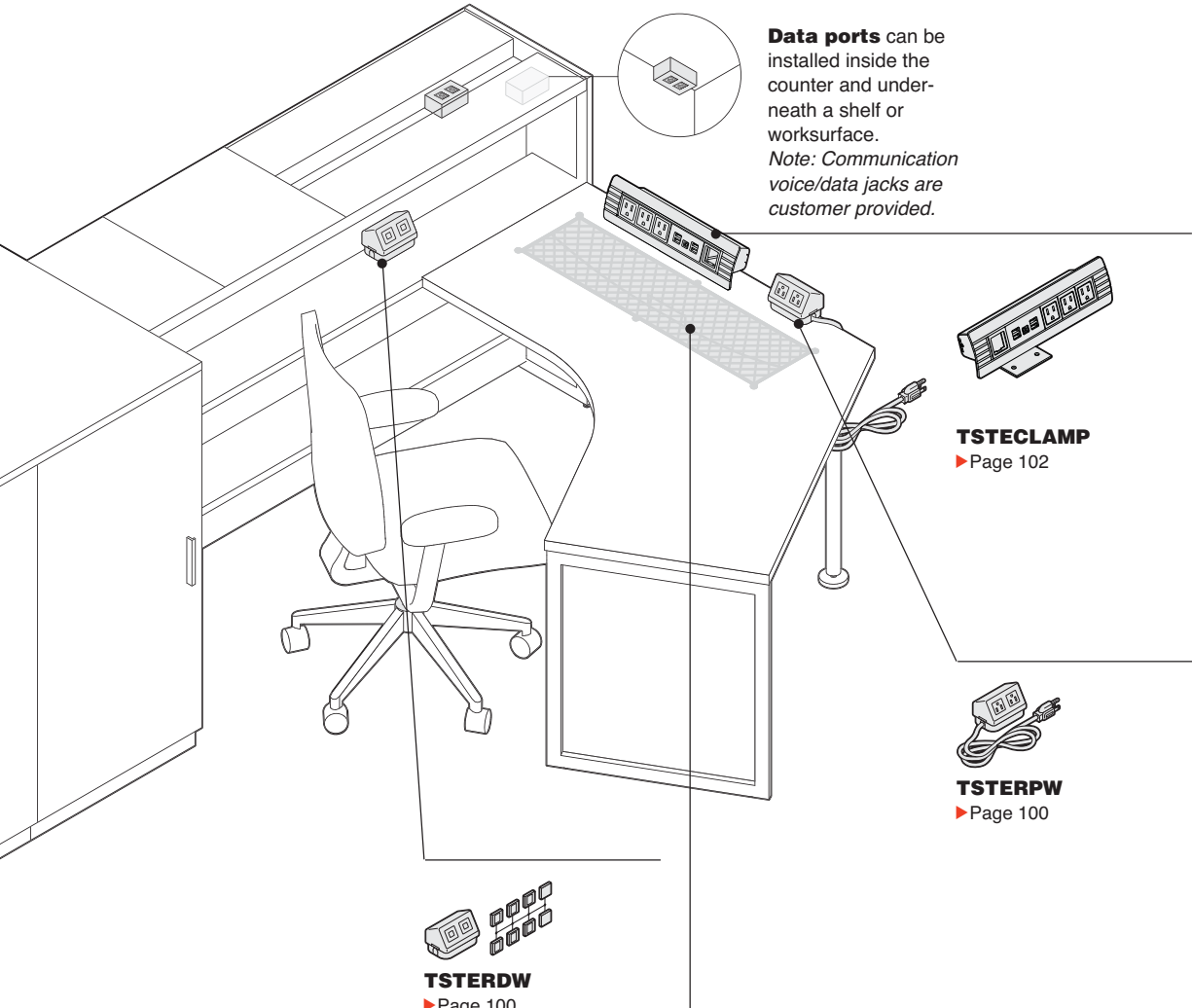

**Data ports** can be installed inside the counter and underneath a shelf or worksurface.  
*Note: Communication voice/data jacks are customer provided.*

**Tour clamp-on accessories** work on surfaces 3/4" to 1 1/4" thick. They do not work on surfaces over 1 1/4" thick.

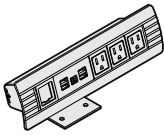

**TSTECLAMP**  
 ▶ Page 102



**TSTERPW**  
 ▶ Page 100

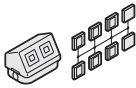

**TSTERDW**  
 ▶ Page 100

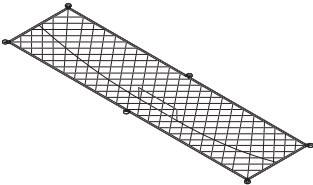

**Elastic mesh cable bag (TSTECB)** keeps cords secure while providing easy access points.  
 ▶ Page 102

# Bench Component Facts

**Tour benching products** consist of a bench trough and screen. The trough has functional dimensions of 4<sup>3</sup>/<sub>8</sub>"D x 10<sup>1</sup>/<sub>2</sub>"W x 60-72"L providing ample space to store and manage cables. The open design allows for quick connect/disconnect access.

**Bench screen** is painted steel and attaches to the center of the bench trough. It accepts magnetic accessories such as the magnetic tackboards and markerboards.

► Specifying, page 105

**The worksurfaces** overhang the bench trough for clamp on accessories. There are also four cut-outs in the trough to provide additional space for clamp on accessories.

**Bench trough** is painted steel and telescopes from 60" to 72" to accommodate different worksurface lengths. When used with two 30" deep worksurfaces the overall depth of worksurface and trough will be 70" to match the counter shelf length. When used with two 24" deep worksurface the overall depth of the worksurface and trough will be inset 6" on both sides of the shelf.

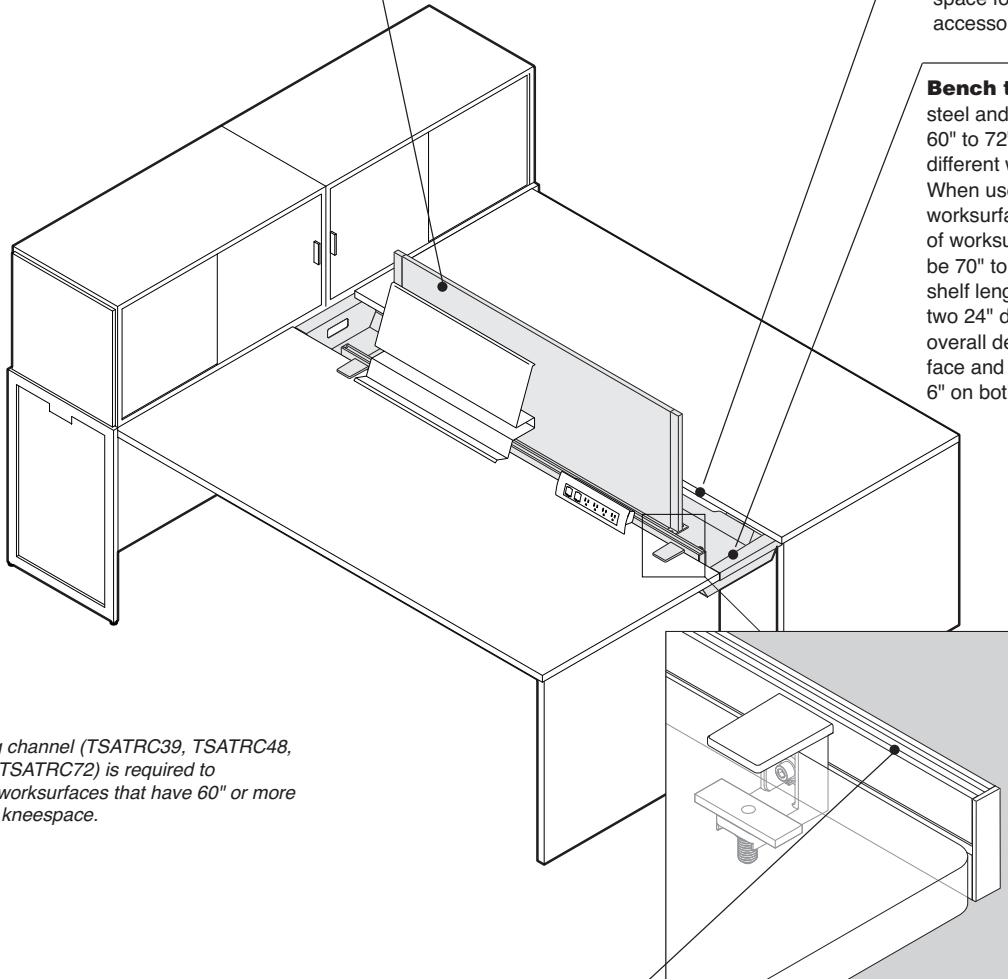

*Tip: Reinforcing channel (TSATRC39, TSATRC48, TSATRC57, or TSATRC72) is required to add support to worksurfaces that have 60" or more of unsupported kneespace.*

**Tour SOTO rail** has attachment hole locations that line up with bench trough cut-outs.

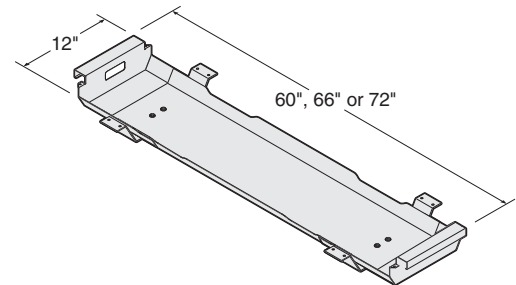

# Worksurface and Shelf Facts

**Worksurface** has a wood core with plastic edge band. Low-Pressure Laminates (LPL) and High-Pressure Laminates (HPL) are available. Plastic edge band color is selectable. Because the actual thickness of LPL, HPL, and wood veneer worksurfaces are slightly different, it is recommended that only worksurfaces of the same type are specified in a single application. In addition, there may be a sheen or texture difference when using LPL or HPL in adjacent applications.

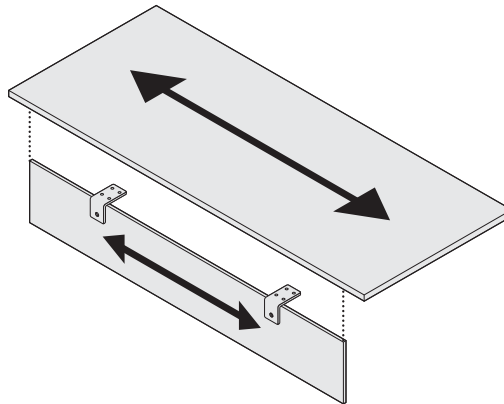

**Shelves** are available in rectangular or extended corner shapes. Shelves can be mounted to one or both sides of the counters at coffee table height (on 30"H counter) or at worksurface height and coffee table height (on 42"H counter). Counters do not require counter-balancing if shelves are on one side only.

**Tour** is available in a variety of worksurface and shelf shapes. Directional laminate grain direction is shown.

**Shelves** can be placed at any height on the counter. \*Note: Holes are pre-drilled at specific heights. When planning to have a worksurface attached, be sure to place the shelf at a height that can be accommodated by a worksurface support. Height-adjustable post legs and the adjustable round table bases allow for some flexibility.

**Palletizing** streamlines unloading and staging of worksurfaces. Identical worksurfaces ordered on the same line item are packed on pallets containing 10–20 worksurfaces. Remaining worksurfaces are packed individually in cartons. If palletizing is not desired, order in quantities of nine or less per line item. For maximum unload efficiency, utilize pallet handling equipment at job site whenever possible.

**21"D and 33"D shelves** extend 12" and 24" respectively outside the footprint of a counter. When a worksurface is attached to a shelf in a return configuration, the workstation can be wrapped in screens as a 6" module is maintained. *Tip: These shelves require additional support such as a post leg or an end panel support.*

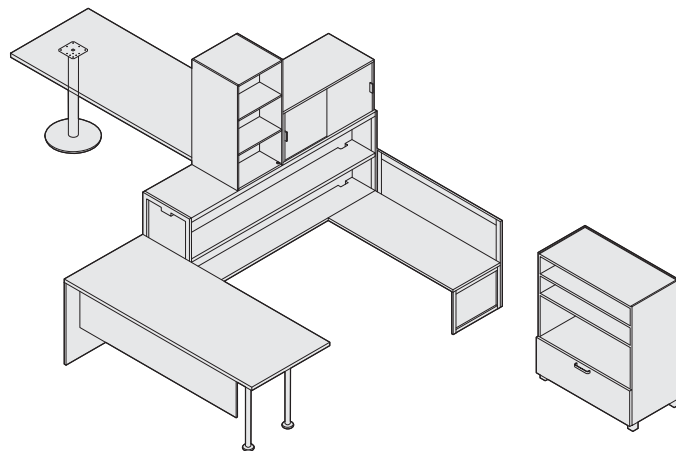

► Specifying, pages 107-110, 115

**User's edge profile** is plastic with a 3 mm radius. Back edge and edge that joins to adjacent worksurface is 1 mm.

**All shelves** have a cutout for vertical cord manager.

**21"D and 33"D rectangular shelves and corner shelf** require additional support of a post leg or end support.

Note: 21"D shelf provides 12" of worksurface space beyond the counter, the 33"D shelf provides 24".

*Tip: Reinforcing channel (TSATRC39, TSATRC48, TSATRC57, or TSATRC72) is required to add support to worksurfaces that have 60" or more of unsupported kneespace.*

# Worksurface Supports Facts

**Supports** are ordered separately and installed in the field.

**Mounting hardware** is included with each type of support.

**Recommended worksurface supports for some specific applications** are shown below.

**Frame worksurface support** cannot support both ends of a freestanding worksurface. Frame worksurface support has leveling glides. Use a laminate worksurface support, two post legs, Currency square legs, or a round table base on one end.

► Specifying, pages 112-114

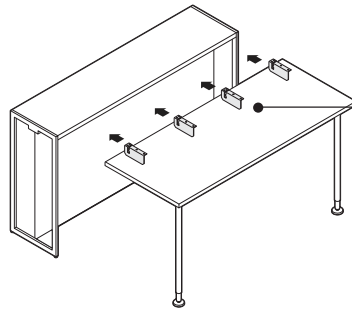

**If worksurface** is attached directly to the top of counter in a parallel application, two sets of counter-to-worksurface tie plates are required.

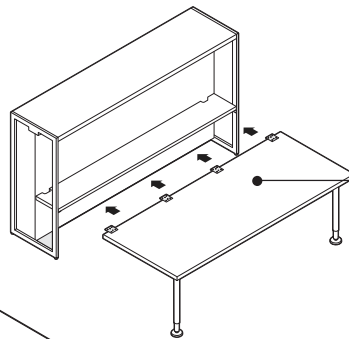

**If worksurface** is attached to a shelf in a parallel application, two sets of shelf-to-worksurface tie plates are required.

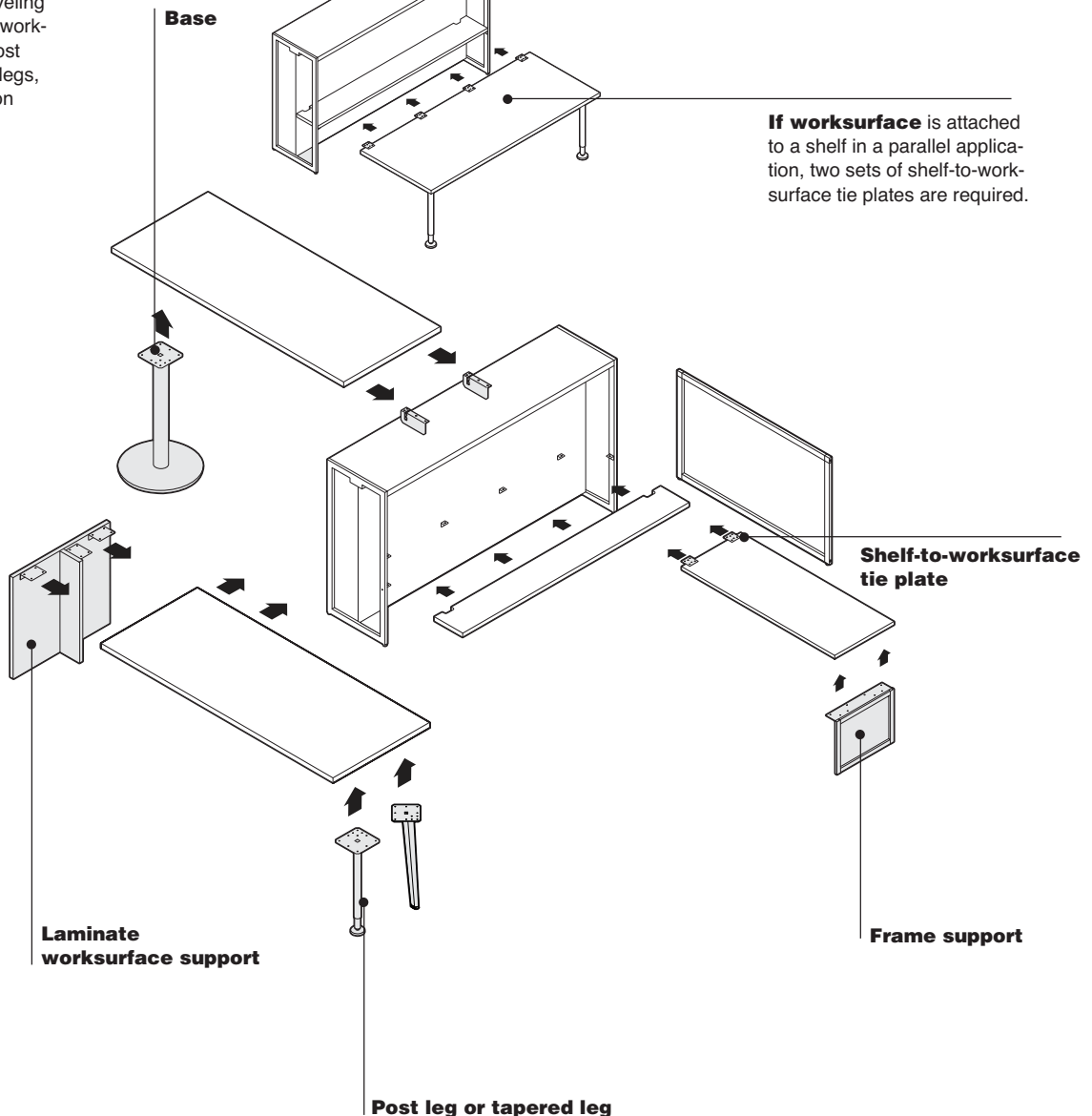

► Specifying, pages 112–114

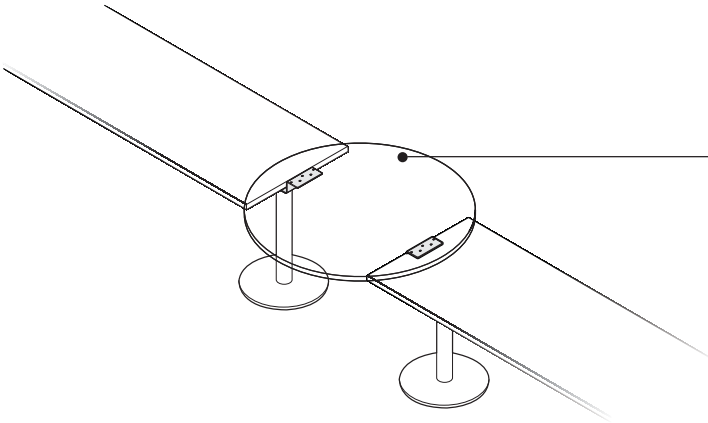

**Floating round work-surface support** is approved to work with 30" and 36" diameter work-surfaces. Round work-surfaces can overlap a tapered or straight work-surface by 2" minimum to 8" maximum.

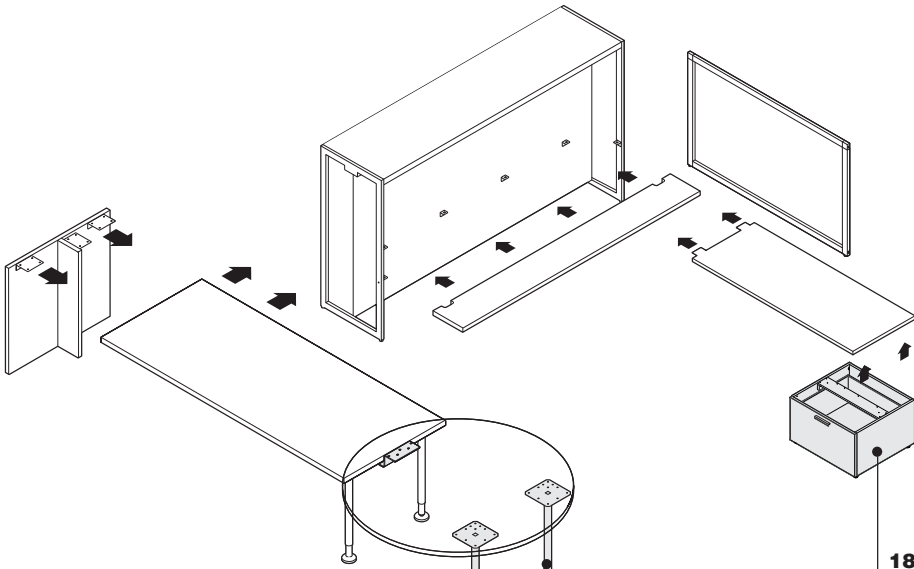

**When only one side of a floating round work-surface** is overlapping, additional support is required, such as two adjustable post legs or a Tour round table base.

**Adjustable-height post legs** are recommended to offset the 1" taller worksurface height.

**18"W my file** cannot be used in a freestanding configuration. My file must be used at the opposite end of a worksurface attached to a counter shelf.

# Screen and Screen Connector Facts

**Screens** are constructed with a clear anodized aluminum frame with a laminate infill.

► Specifying, pages 117–118

**Screens** can be connected inline, 120° screen application with two or three screens, or in L-, or T-configurations to other screens or to counter end supports. Connection hardware is ordered separately.

**Screens** are non-load bearing.

**Screen connection hardware** require a T27 TOR X driver bit.

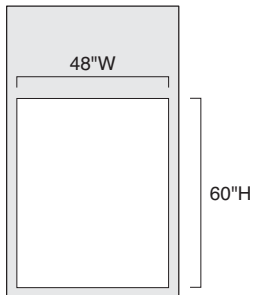

**Tour screens** are not available in widths larger than 48". The laminate infill used in the construction of screens are only available in 4' x 8' sheets. Directional laminates will run vertically on all sizes of Tour screens.

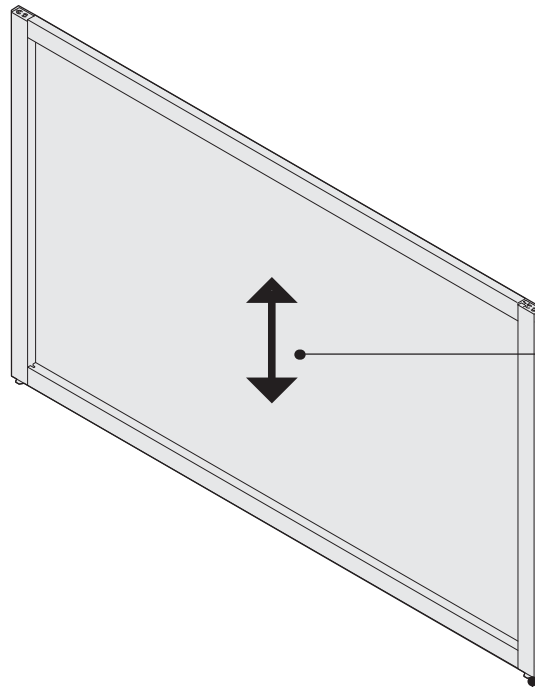

**Directional laminate** is vertical on screen infills.

**Leveling glides** adjust 1/2" to accommodate uneven floors.

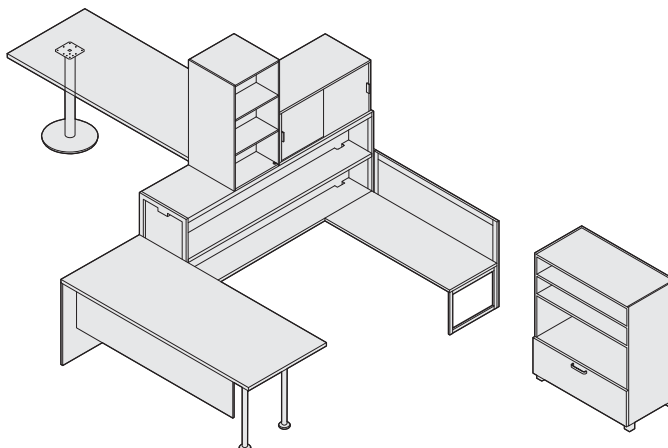

**Screen connectors** are steel components that facilitate the attachment of screens in different configurations. Brackets are ordered separately.

► Specifying, pages 117–118

**Two-way same height (Inline or L-configuration, TSTPBSH2)**

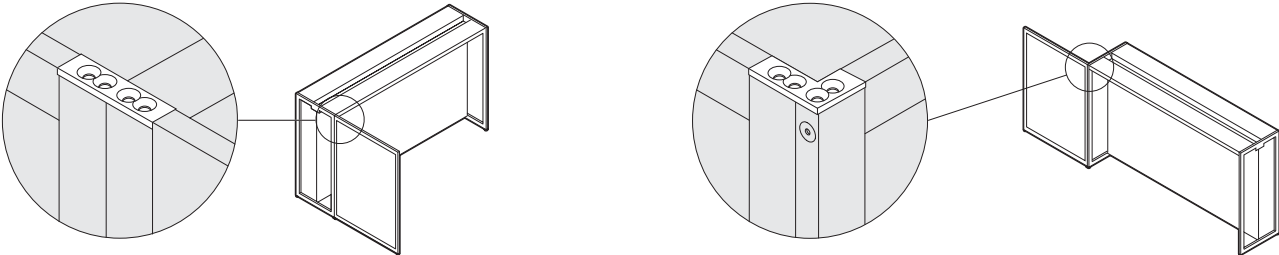

**Three-way same height (T-configuration, TSTPBSH3)**

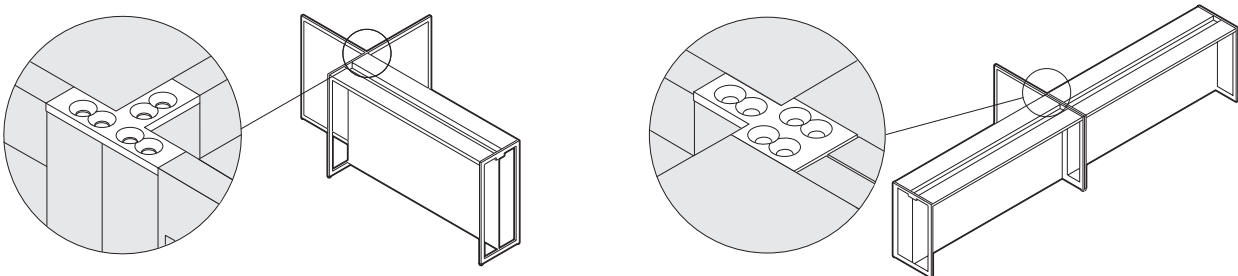

**Two-way change-of-height (Inline or L-configuration, TSTPBCOH2)**

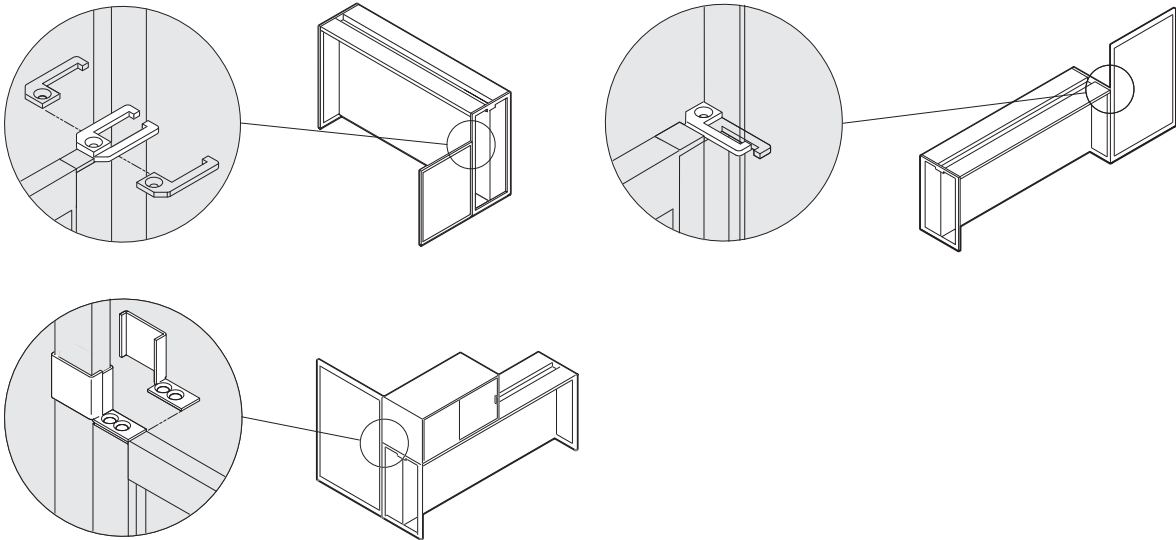

**Three-way change-of-height (T-configuration, TSTPBCOH3)**

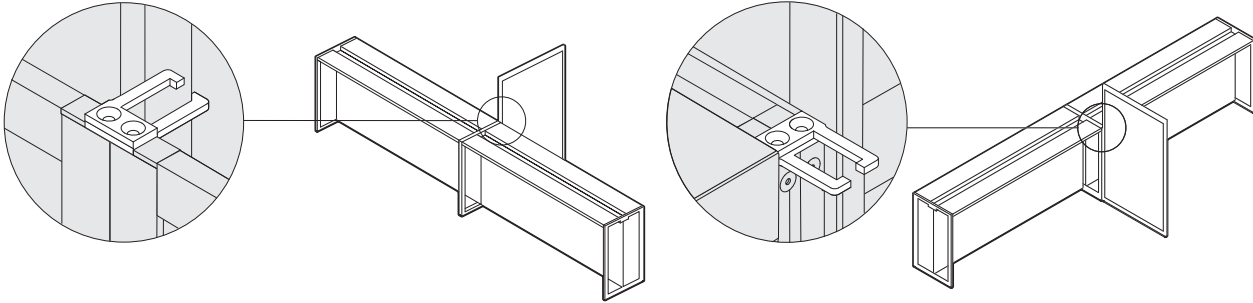

**Two-way same height (120° configuration, TSTPB120)**

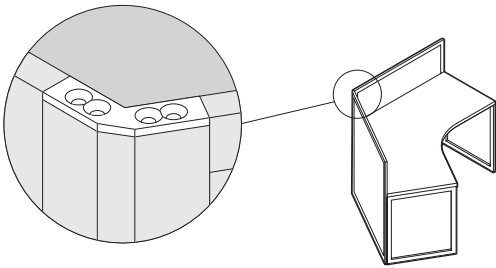

\* Two-way 120° brackets can only be used when both screens are at the same height.

**Three-way same height (120° configuration, TSTPB120Y)**

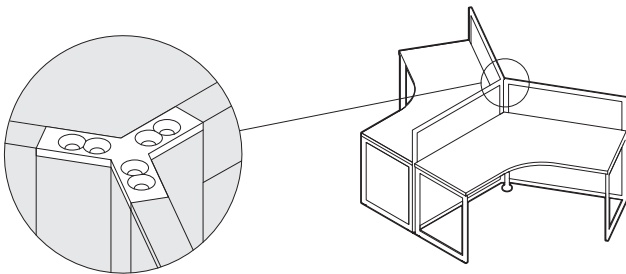

\* Three-way 120° brackets can only be used when all screens are at the same height.

**Worksurface-to-screen (TSTPBWT)**

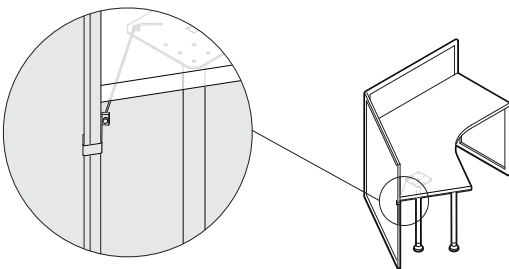

\* Worksurface-to-screen tie draws the screen tighter to the worksurface when at the end of a configuration.

# Freestanding Screen Stability Rules

► Specifying, pages 117–118

## U-configuration with two screens

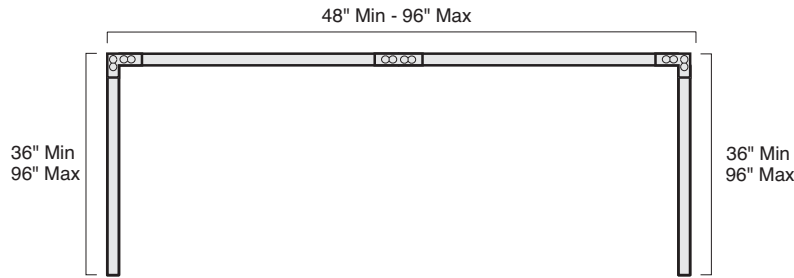

## L-configuration with two screens

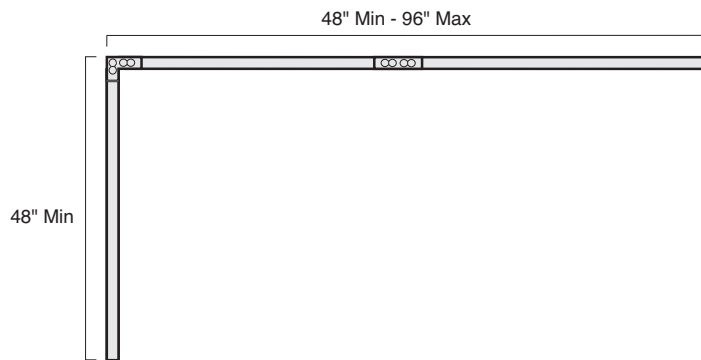

## L-configuration with one screen

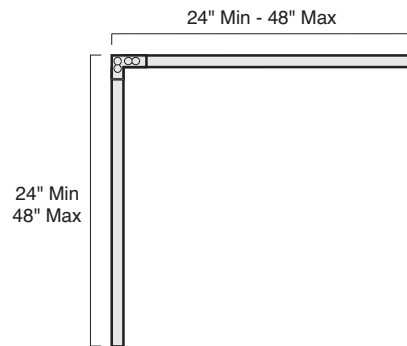

## T-configuration

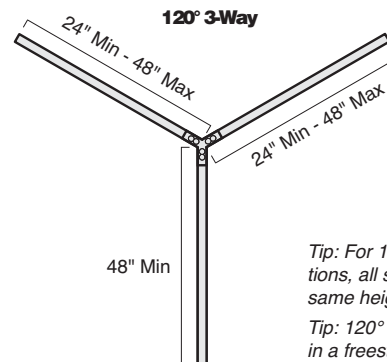
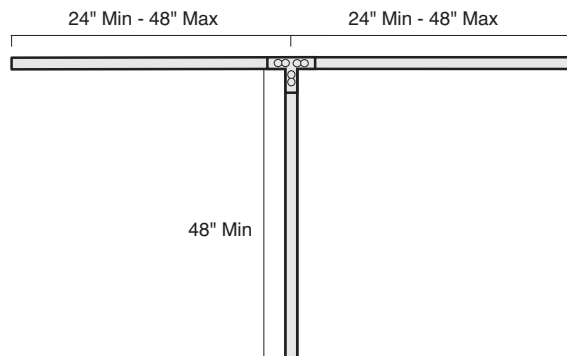

*Tip: For 120° screen applications, all screens must be the same height.*

*Tip: 120° 2-way not available in a freestanding application.*

# HV Cabinet Facts

► Specifying, pages 119–120

**HV cabinet** is a steel cabinet with a laminate center divider and a 7"D steel shelf. The HV cabinet is designed to sit on its side or end on a counter or on its side on a pile file. Two cabinets laid on their side fit on a counter, and take the place of a countertop.

*Tip: HV cabinet center divider laminate color number defaults based on the paint selection.*

► Page 128

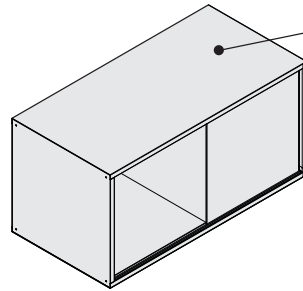

**Shared HV cabinet** gives users on both sides one 18"D x 18"W cube for storage. Available open or with the option of a door on each side. The shared HV cabinet is a steel cabinet with a steel center divider, but it does not have a 7"D steel shelf.

**Sliding doors with pulls** are optional on the HV cabinet and can be ordered as a single or double door. Sliding doors can be ordered in laminate. Optional doors do not lock.

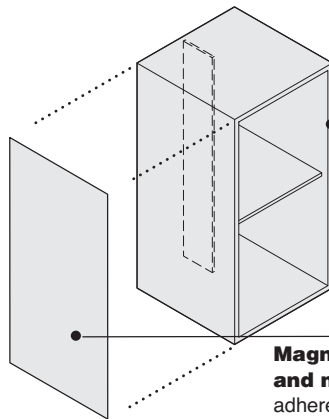

**HV cabinet without doors**

**Magnetic markerboard and magnetic tackboard** adhere to steel sides and backs of HV cabinet for user-friendly writing surface, notes, and pictures.

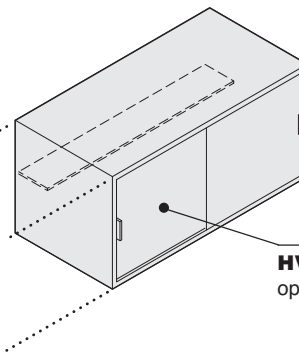

**HV cabinet** shown with optional laminate doors.

**Horizontal/vertical cabinets** ship fully assembled.

**For stability**, if three HV cabinets are placed on top of a counter, one of the HV cabinets must be on its side.

**Up to three HV cabinets** can be placed on top of one counter.

**For stability, the HV cabinet** comes with four small screws to attach the HV cabinet to the counter for the following conditions:

- When the HV cabinet is in a vertical position in a seismic zone.
- When the HV cabinet is in a vertical position without another HV cabinet next to it.

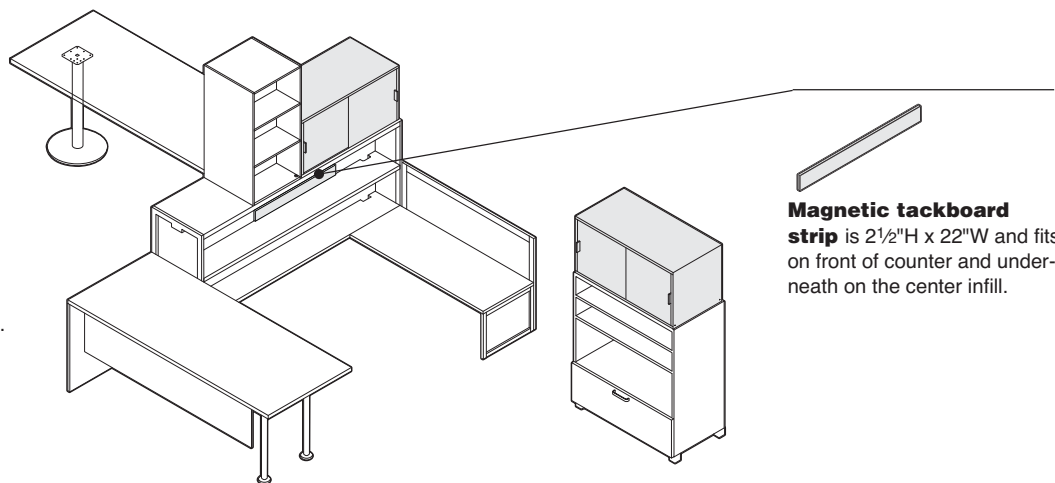

**Magnetic tackboard strip** is 2½"H x 22"W and fits on front of counter and underneath on the center infill.

# Bookcase Facts

**Shared bookcase** is a laminate cabinet with a center divider between the front and back; and two fixed shelves on each side. Primary use is a shared component between users on opposite sides of counter. The shared bookcase is designed to sit on it's side or end, on a counter, or on it's side on a pile file. A bookcase takes the place of countertops.

► Specifying, page 121

**Personal bookcase** is a one-sided laminate cabinet with one fixed shelf. Primary use is as a personal bookcase accessible from one side of a counter. If used on a counter, two personal bookcases must be ordered and placed back-to-back to take the place of one 18"W x 18"W countertop.

A personal bookcase can be specified with optional feet for use at the bottom of a counter. Includes a bracket to connect to bottom horizontal frame of counter.

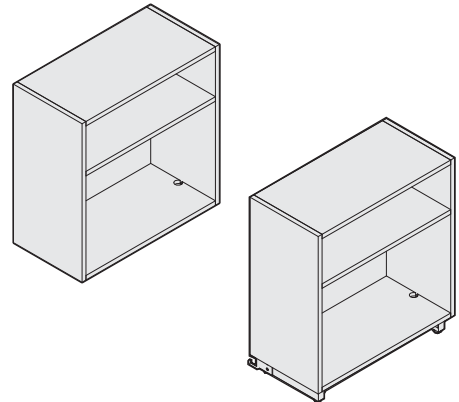
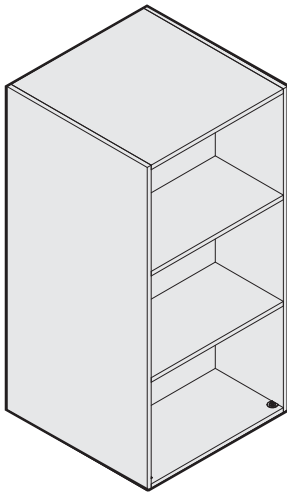

Shared bookcase and personal bookcase ship fully-assembled. Optional feet for personal bookcase must be field-assembled.

## Possible Configurations of HV Cabinets and Bookcases

**Two personal bookcases** (placed back-to-back) can replace one HV cabinet or shared bookcase in the vertical position.

**No more than three HV cabinets or shared bookcases** may be placed on a single counter. When three components are placed on a single counter, one component **MUST** be laying on it's 36"W side.

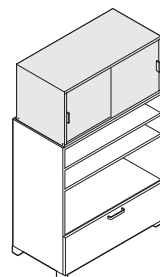
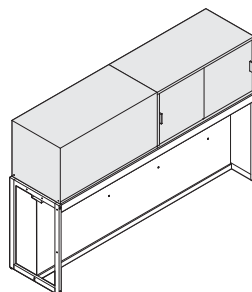
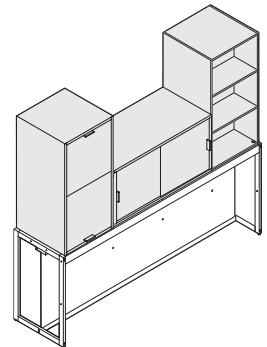
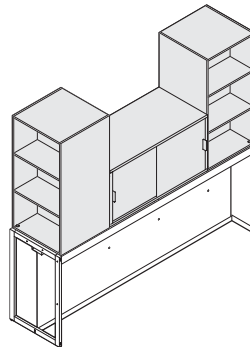
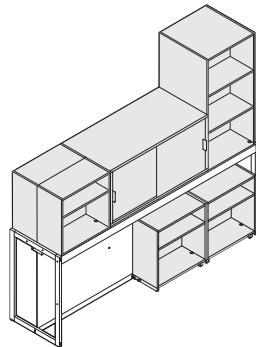

**A single HV cabinet or shared bookcase** can be mounted in a horizontal position on top of a pile file.

# My File Facts

► Specifying, pages 122–123

**My file** is constructed of laminate sides and drawer front with steel drawer body. My file has a full 22" of functional depth. Back of drawer has metal box with an open floor and accommodates suspended side-to-side letter filing. Front of drawer has an unique 9" x 18" storage cubby to store personal items.

**Back of drawer** has metal box with an open floor and accommodates suspended side-to-side letter filing.

**Top** is open to attach beneath a worksurface. A 6" minimum of worksurface is required beyond the footprint of the file to attach to the counter shelf. Example: if (2) two my files are used  $18" + 18" = 36"$ , a 42" worksurface or longer must be used.

**Drawer** has an optional front-removable lock.

**Ledge pull** is standard on the my file.

**Front of drawer** has a unique 9" x 18" storage cubby to store personal items.

**Freestanding configuration** cannot be used with my files. It must be at the opposite end of a worksurface that is attached to a counter shelf.

**Lateral file cushion** is used on top of a worksurface over my file or worksurface frame support.

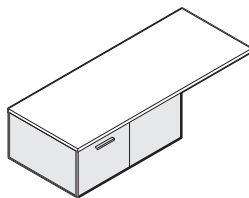
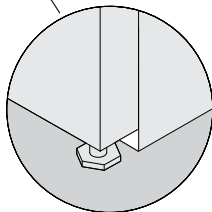

**My file** can be installed in opposite directions to accommodate two users.

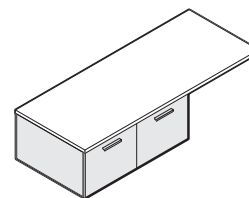

**My file** can be installed side-by-side for twice the storage and filing capability.

**Multiple my files** can be installed next to one another facing the same direction or in opposite directions just as long as there is 6" minimum open worksurface left to attach to the counter shelf.

# Pile File Facts

**Pile file** is constructed of laminate sides and drawer front with a steel back and top. Two pullout laminate shelves and a full-size lateral file drawer provide storage and user flexibility.

► Specifying, page 124

**Ledge pull** is standard on the lateral file drawer.

**Two 18"W or one 36"W countertop** nestle into the top of a pile file to provide a flush surface. Countertops are ordered separately.

**Lateral file drawer** accommodates letter-size side-to-side filing. For legal-size front-to-back filing, use 15" universal storage rail RXADRL15.

**Lateral file drawer** has an optional front-removable lock.

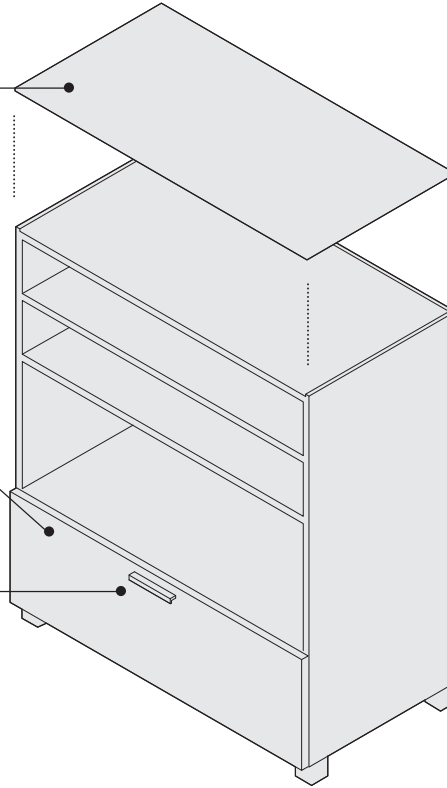

Tour Workspace

**Pile file top and back** can be covered with a magnetic markerboard or tackboard for a user-friendly writing surface.

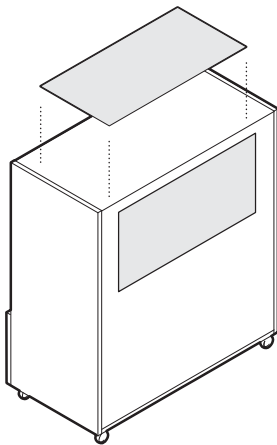

**Optional casters** allow for mobility.

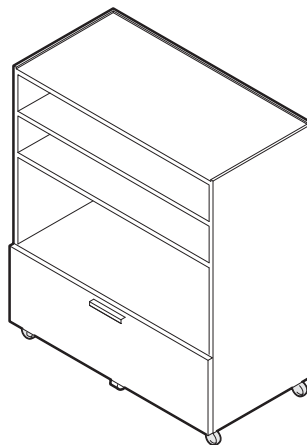

**Top of pile file** can be left open or accommodate a HV cabinet.

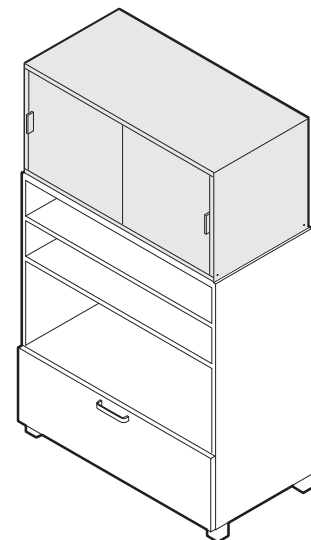

# Counters

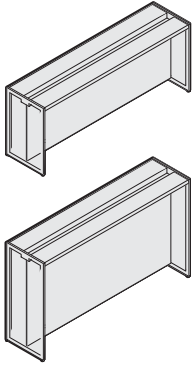

Tip: Woodgrain laminate runs horizontal on the counter center infill and vertically on the optional end panel infills.

Tip: Optional power does not include base-in. Refer to electrical components for more information on page 92.

Tip: For 2-circuit or 4-circuit power, refer to electrical components on page 92.

Standard Includes	Required to Specify
-------------------	---------------------

- |   |  |   |
|---|--|---|
| <ul style="list-style-type: none"> <li>▶ Need help? Product details, page 67</li> </ul> | <ul style="list-style-type: none"> <li>• Counter top tray: paint price group 1</li> <li>• Counter frame support: Clear Anodized Aluminum</li> <li>• Center infill: laminate</li> <li>• Adjustable leveling glides</li> <li>• Counter-to-counter attachment hardware: 4799 Platinum</li> <li>• Shipped ready to assemble</li> </ul> | <ul style="list-style-type: none"> <li>1 Style number</li> <li>2 Paint color number for counter top tray</li> <li>3 Laminate color number for center infill</li> <li>4 Options, if selected (see below)</li> <li>▶ See <i>Surface Materials</i>, page 128.</li> </ul> |
|---|--|---|

Surface Materials	Options	U.S. Price	Required to Specify
-------------------	---------	------------	---------------------

<b>Surface Materials</b>	<b>Counter top tray</b>		
	• Paint price group 1	No cost	Specify paint color number.
	• Paint price group 2	+\$ 32	Specify paint color number.
	<b>Steel center infill</b>		
	• Paint price group 1	30"H +\$217	Specify paint color number.
	• Paint price group 2	30"H +\$269	Specify paint color number.
	• Paint price group 1	42"H +\$326	Specify paint color number.
	• Paint price group 2	42"H +\$377	Specify paint color number.
	<b>End panel infill (both ends)</b>		
	• Laminate	30"H +\$ 83	Specify laminate color number.
	• Laminate	42"H +\$111	Specify laminate color number.

Electrical	Factory-installed powerway	U.S. Price	Required to Specify
------------	----------------------------	------------	---------------------

	• 1-circuit power	+\$200	Specify with 1-circuit power.
--	-------------------	--------	-------------------------------

Related Products	Options	Required to Specify
<ul style="list-style-type: none"> <li>• Countertops</li> <li>• Electrical components</li> <li>• Magnetic tackboard</li> </ul>		<ul style="list-style-type: none"> <li>▶ Page 91</li> <li>▶ Page 92</li> <li>▶ Page 125</li> </ul>

## Specification Information

Dimensions			Style Number	U.S. Base Price
D	W	H		
18"	72"	30"	<b>TSTMC3072</b>	\$ 979
18"	72"	42"	<b>TSTMC4272</b>	\$1102



**For Canadian Pricing**  
 Multiply U.S. Price by the Canadian price factor.  
 ▶ See page 1 for details.

Standard Includes		Required to Specify
▶ Need help? Product details, page 67	<ul style="list-style-type: none"> <li>Countertop: laminate</li> <li>Shipped ready to assemble</li> </ul>	1 Style number 2 Laminate color number for countertop ▶ See <i>Surface Materials</i> , page 128.

Related Products	
<ul style="list-style-type: none"> <li>Counters</li> </ul>	▶ Page 90

### Specification Information

Dimensions		Style Number	U.S. Price
D	W		

Countertops			
18"	18"	<b>TSTMCT1818</b>	\$ 56
18"	36"	<b>TSTMCT1836</b>	\$ 92
18"	54"	<b>TSTMCT1854</b>	\$122
18"	72"	<b>TSTMCT1872</b>	\$171
:	:	:	:

Notched Countertops			
18"	18"	<b>TSTMCTN1818</b>	\$ 61
18"	36"	<b>TSTMCTN1836</b>	\$ 98
18"	54"	<b>TSTMCTN1854</b>	\$129
18"	72"	<b>TSTMCTN1872</b>	\$178
:	:	:	:

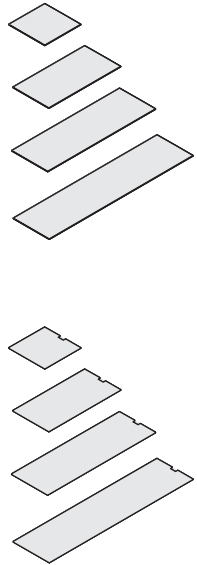

 **For Canadian Pricing**  
 Multiply U.S. Price by the Canadian price factor.  
 ▶ See page 1 for details.

# Electrical Components

## Base Power-Ins

Standard Includes	Required to Specify
<ul style="list-style-type: none"> <li>▶ Need help? Product details, page 68</li> <li>• Receptacle base power-in, 24" long cord with wall plug</li> <li>• 1-circuit or 2-circuit hardwired base power-in, 94" long x 3/8" diameter flexible galvanized steel conduit</li> <li>• Modular connection for 1-circuit or 2-circuit powerway</li> <li>• In-line connector to allow connection at middle of run</li> <li>• 4-circuit hardwired base power-in                             <ul style="list-style-type: none"> <li>- One hardwired base power-in with Line 1 and Line 2 receptacle, and a 94" long x 3/8" diameter flexible galvanized steel conduit</li> <li>- One hardwired base power-in with Line 3 and Line 4 receptacle, and a 124" long x 3/8" diameter flexible galvanized steel conduit</li> </ul> </li> </ul>	Style number

Related Products
<ul style="list-style-type: none"> <li>• Powerways</li> </ul>

▶ Page 94

Specification Information		
Counter Height	Style Number	U.S. Price

### Receptacle Base Power-In, 1-Circuit, Line 1 Only

30"	<b>TSTEPBR130</b>	\$111
42"	<b>TSTEPBR142</b>	\$122

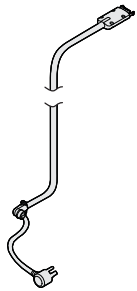

### Hardwired Base Power-In, 1-Circuit or 2-Circuit, Line 1 and Line 2

94"	<b>TSTEPBT2</b>	\$111



### San Francisco Base Power-In, 1-Circuit or 2-Circuit, Line 1 and Line 2

30"	<b>TSTEPBT230SF</b>	\$139
42"	<b>TSTEPBT242SF</b>	\$139

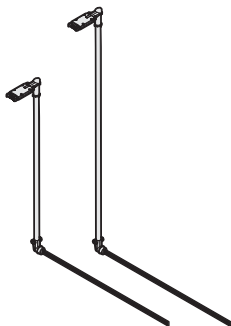

▶ Specification Information, continued on next page

► Specification Information, continued from previous page

**Specification Information**

Counter Height	Style Number	U.S. Price
----------------	--------------	------------

**Hardwired Base Power-In, 4-Circuit, Line 1 and Line 2, Line 3 and Line 4**

94", 124"	<b>TSTEPBT4</b>	\$278
-----------	-----------------	-------

**San Francisco Base Power-In, 4-Circuit, Line 1 and Line 2, Line 3 and Line 4**

30"	<b>TSTEPBT430SF</b>	\$306
42"	<b>TSTEPBT442SF</b>	\$306

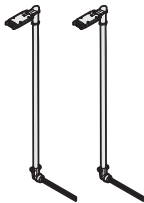

Tour Workspace



**For Canadian Pricing**  
 Multiply U.S. Price by the Canadian price factor.  
 ► See page 1 for details.

## Powerways

*Tip: Power runs through spine of counter and is "plug-and-play".*

Standard Includes	Required to Specify
<ul style="list-style-type: none"> <li>▶ Need help? Product details, page 68</li> </ul>	<ul style="list-style-type: none"> <li>• 72" powerway with four duplex receptacles for 1-circuit and 2-circuit powerways: 6000 black</li> <li>• 72" powerway for 4-circuit with (1) Line 1 and (1) Line 2 receptacle, and (1) Line 3 and (1) Line 4 receptacle</li> <li>• Shipped ready to install</li> </ul>
	Style number

Related Products	
• Counters	▶ Page 90

### Specification Information

• Style Number	• U.S. Price

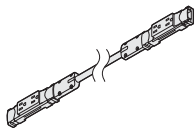

*Tip: Conduit comes from the base power-in.*

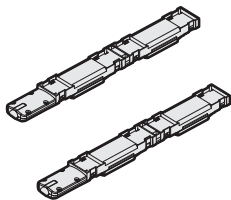

#### 1-Circuit Powerway - Line 1 Only

<b>TSTEP172</b>	\$200

#### 2-Circuit Powerway - Line 1 and Line 2

<b>TSTEP272</b>	\$240

#### 4-Circuit Powerway - Line 1 and Line 2 Receptacle, Line 3 and Line 4 Receptacle

<b>TSTEP472</b>	\$189



**For Canadian Pricing**  
 Multiply U.S. Price by the Canadian price factor.  
 ▶ See page 1 for details.

### Counter-to-Counter Power Connector, 1-Circuit and 2-Circuit

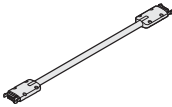

Standard Includes	Required to Specify
<ul style="list-style-type: none"> <li>▶ Need help? Product details, page 68</li> <li>• Modular counter-to-counter power connector</li> </ul>	Style number

Related Products	
<ul style="list-style-type: none"> <li>• Counters</li> <li>• Powerways</li> </ul>	<ul style="list-style-type: none"> <li>▶ Page 90</li> <li>▶ Page 94</li> </ul>

Specification Information	
• Style Number	• U.S. Price
TSTEPC2C	\$66

Tour Workspace

### Counter-to-Counter Power Connector, 4-Circuit

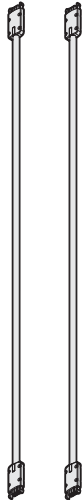

Standard Includes	Required to Specify
<ul style="list-style-type: none"> <li>▶ Need help? Product details, page 68</li> <li>• Modular counter-to-counter power connector</li> </ul>	Style number

Related Products	
<ul style="list-style-type: none"> <li>• Counters</li> <li>• Powerways</li> </ul>	<ul style="list-style-type: none"> <li>▶ Page 90</li> <li>▶ Page 94</li> </ul>

Specification Information	
• Style Number	• U.S. Price
TSTEPC2C4	\$156

 **For Canadian Pricing**  
 Multiply U.S. Price by the Canadian price factor.  
 ▶ See page 1 for details.

**Power Jumper, 1-Circuit and 2-Circuit**

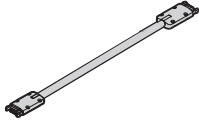

*Tip: Power jumpers ship with one or two horizontal cord managers, TSTECW, depending on the length of the power jumper.*

Standard Includes	Required to Specify
<ul style="list-style-type: none"> <li>▶ Need help? Product details, page 72</li> <li>• Modular counter-to-counter power jumper</li> <li>• Horizontal wire manager: black plastic</li> <li>• Attachment hardware</li> </ul>	<ul style="list-style-type: none"> <li>Style number</li> </ul>

Related Products	
<ul style="list-style-type: none"> <li>• Counters</li> <li>• Powerways</li> </ul>	<ul style="list-style-type: none"> <li>▶ Page 90</li> <li>▶ Page 94</li> </ul>

**Specification Information**

Length	Style Number	U.S. Price
69"	<b>TSTEP2C069</b>	\$223
75"	<b>TSTEP2C075</b>	\$223
81"	<b>TSTEP2C081</b>	\$223
87"	<b>TSTEP2C087</b>	\$223
93"	<b>TSTEP2C093</b>	\$223
99"	<b>TSTEP2C099</b>	\$223
105"	<b>TSTEP2C105</b>	\$223
111"	<b>TSTEP2C111</b>	\$223
117"	<b>TSTEP2C117</b>	\$223
120"	<b>TSTEP2C120</b>	\$223
123"	<b>TSTEP2C123</b>	\$223
126"	<b>TSTEP2C126</b>	\$223
129"	<b>TSTEP2C129</b>	\$223
132"	<b>TSTEP2C132</b>	\$223
135"	<b>TSTEP2C135</b>	\$223
138"	<b>TSTEP2C138</b>	\$223
141"	<b>TSTEP2C141</b>	\$223
144"	<b>TSTEP2C144</b>	\$223
147"	<b>TSTEP2C147</b>	\$223
150"	<b>TSTEP2C150</b>	\$223
153"	<b>TSTEP2C153</b>	\$223
156"	<b>TSTEP2C156</b>	\$223
159"	<b>TSTEP2C159</b>	\$223
162"	<b>TSTEP2C162</b>	\$306
165"	<b>TSTEP2C165</b>	\$306
168"	<b>TSTEP2C168</b>	\$306
171"	<b>TSTEP2C171</b>	\$306
174"	<b>TSTEP2C174</b>	\$306

▶ **Specification Information, continued on next page**



**For Canadian Pricing**  
 Multiply U.S. Price by the Canadian price factor.  
 ▶ See page 1 for details.

► Specification Information, continued from previous page

**Specification Information**

Length	Style Number	U.S. Price
177"	<b>TSTEP2C177</b>	\$306
180"	<b>TSTEP2C180</b>	\$306
183"	<b>TSTEP2C183</b>	\$306
186"	<b>TSTEP2C186</b>	\$306
189"	<b>TSTEP2C189</b>	\$306
192"	<b>TSTEP2C192</b>	\$306
195"	<b>TSTEP2C195</b>	\$306
198"	<b>TSTEP2C198</b>	\$306
201"	<b>TSTEP2C201</b>	\$334
204"	<b>TSTEP2C204</b>	\$334
207"	<b>TSTEP2C207</b>	\$334
210"	<b>TSTEP2C210</b>	\$334
213"	<b>TSTEP2C213</b>	\$334
216"	<b>TSTEP2C216</b>	\$334
219"	<b>TSTEP2C219</b>	\$334
222"	<b>TSTEP2C222</b>	\$334
225"	<b>TSTEP2C225</b>	\$334
228"	<b>TSTEP2C228</b>	\$334
:	:	:

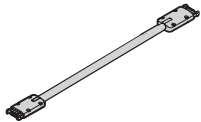

Tour Workspace

  
**For Canadian Pricing**  
 Multiply U.S. Price by the  
 Canadian price factor.  
 ► See page 1 for details.

### Power Jumper, 4-Circuit

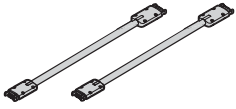

*Tip: Power jumpers ship with one or two horizontal cord managers, TSTECW, depending on the length of the power jumper.*

Standard Includes	Required to Specify
<ul style="list-style-type: none"> <li>▶ Need help? Product details, page 72</li> <li>• Modular counter-to-counter power jumpers</li> <li>• Horizontal wire manager: black plastic</li> <li>• Attachment hardware</li> </ul>	<ul style="list-style-type: none"> <li>Style number</li> </ul>

Related Products
<ul style="list-style-type: none"> <li>• Counters <span style="float: right;">▶ Page 90</span></li> <li>• Powerways <span style="float: right;">▶ Page 94</span></li> </ul>

Specification Information		
Length	Style Number	U.S. Price
96"	<b>TSTEP4C096</b>	\$417
102"	<b>TSTEP4C102</b>	\$417
108"	<b>TSTEP4C108</b>	\$417
114"	<b>TSTEP4C114</b>	\$417
120"	<b>TSTEP4C120</b>	\$417
126"	<b>TSTEP4C126</b>	\$417
132"	<b>TSTEP4C132</b>	\$417
138"	<b>TSTEP4C138</b>	\$417
144"	<b>TSTEP4C144</b>	\$417
147"	<b>TSTEP4C147</b>	\$417
150"	<b>TSTEP4C150</b>	\$417
153"	<b>TSTEP4C153</b>	\$417
156"	<b>TSTEP4C156</b>	\$417
159"	<b>TSTEP4C159</b>	\$417
162"	<b>TSTEP4C162</b>	\$501
165"	<b>TSTEP4C165</b>	\$501
168"	<b>TSTEP4C168</b>	\$501
171"	<b>TSTEP4C171</b>	\$501
174"	<b>TSTEP4C174</b>	\$501
177"	<b>TSTEP4C177</b>	\$501
180"	<b>TSTEP4C180</b>	\$501
183"	<b>TSTEP4C183</b>	\$501
186"	<b>TSTEP4C186</b>	\$501
189"	<b>TSTEP4C189</b>	\$501
192"	<b>TSTEP4C192</b>	\$501
195"	<b>TSTEP4C195</b>	\$501
198"	<b>TSTEP4C198</b>	\$501

▶ **Specification Information, continued on next page**

**For Canadian Pricing**  
 Multiply U.S. Price by the Canadian price factor.  
 ▶ See page 1 for details.

► Specification Information, continued from previous page

**Specification Information**

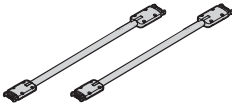

Length	Style Number	U.S. Price
201"	<b>TSTEP4C201</b>	\$529
204"	<b>TSTEP4C204</b>	\$529
207"	<b>TSTEP4C207</b>	\$529
210"	<b>TSTEP4C210</b>	\$529
213"	<b>TSTEP4C213</b>	\$529
216"	<b>TSTEP4C216</b>	\$529
219"	<b>TSTEP4C219</b>	\$529
222"	<b>TSTEP4C222</b>	\$529
225"	<b>TSTEP4C225</b>	\$529
228"	<b>TSTEP4C228</b>	\$556
231"	<b>TSTEP4C231</b>	\$556
234"	<b>TSTEP4C234</b>	\$556
237"	<b>TSTEP4C237</b>	\$556
240"	<b>TSTEP4C240</b>	\$556
243"	<b>TSTEP4C243</b>	\$556
246"	<b>TSTEP4C246</b>	\$556
249"	<b>TSTEP4C249</b>	\$556
252"	<b>TSTEP4C252</b>	\$556
255"	<b>TSTEP4C255</b>	\$556
:	:	:

Tour Workspace



**For Canadian Pricing**  
Multiply U.S. Price by the Canadian price factor.  
► See page 1 for details.

# Worksurface-Height Power and Communication Accessories

## Worksurface Clamp-On Receptacle Packages



Tip: Tour clamp-on accessories work on surfaces 3/4" to 1 1/4" thick. They do not work on surfaces over 1 1/4" thick.

Standard Includes	Required to Specify
<ul style="list-style-type: none"> <li>▶ Need help? Product details, page 77</li> <li>• Package of three</li> <li>• Duplex receptacles: black plastic only</li> <li>• 9' cord with three-prong plug: black plastic only</li> </ul>	Style number

### Specification Information

Style Number	U.S. Price
TSTERPW	\$155

## Worksurface Clamp-On Communication Module Packages

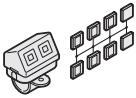

Tip: Many of the AMP, AT&T, Krone, Leviton, and other commercially available data terminals can be used—terminals must be of a design that will snap into 0.695 x 0.650, 0.590 x 0.790, or 0.590 x 0.750 openings, in 0.064 maximum thick faceplates.

Tip: Order jacks by calling any of the manufacturers listed below:

- AMP Corporation  
1.800.522.6752
- Leviton  
1.800.722.2082
- Lucent  
1.800.344.0223
- Krone  
1.800.775.5766
- Punduit  
1.800.777.3300

Tip: Tour clamp-on accessories work on surfaces 3/4" to 1 1/4" thick. They do not work on surfaces over 1 1/4" thick.

Standard Includes	Required to Specify
<ul style="list-style-type: none"> <li>▶ Need help? Product details, page 77</li> <li>• Package of three</li> <li>• Communication housing includes faceplates to accommodate customer-supplied voice/data jacks: black plastic only</li> </ul>	Style number

### Specification Information

Style Number	U.S. Price
TSTERDW	\$102

## Worksurface-Mounted Power and Communication Sphere

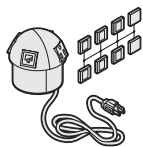

Tip: Sphere is field installed. Use 3"-diameter drill to cut mounting hole at desired location.

Tip: Order jacks by calling any of the manufacturers listed below:

- AMP Corporation  
1.800.522.6752
- Leviton  
1.800.722.2082
- Lucent  
1.800.344.0223
- Krone  
1.800.775.5766
- Punduit  
1.800.777.3300

Standard Includes	Required to Specify
-------------------	---------------------

- |   |  |                     |
|---|--|---------------------|
| <ul style="list-style-type: none"> <li>▶ Need help? Product details, page 76</li> </ul> | <ul style="list-style-type: none"> <li>• Sphere with two simplex electrical outlets: black plastic</li> <li>• Faceplates to accommodate two customer-supplied voice/data jacks: black plastic</li> <li>• 6' power cord with three-prong plug: black plastic</li> </ul> | <p>Style number</p> |
|---|--|---------------------|

Specification Information		
• Style Number	• U.S. Price	

• Style Number	• U.S. Price	
TSTERPDWD	\$214	

## Horizontal Cord Manager

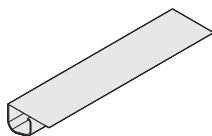

Standard Includes	Required to Specify
-------------------	---------------------

- |   |  |                     |
|---|--|---------------------|
| <ul style="list-style-type: none"> <li>▶ Need help? Product details, page 76</li> </ul> | <ul style="list-style-type: none"> <li>• Horizontal cord manager: 6000 Black plastic</li> <li>• Attachment hardware</li> </ul> | <p>Style number</p> |
|---|--|---------------------|

Related Products	
------------------	--

- |   |   |
|---|---|
| <ul style="list-style-type: none"> <li>• Worksurfaces</li> <li>• Shelves</li> </ul> | <ul style="list-style-type: none"> <li>▶ Pages 107–110</li> <li>▶ Page 115</li> </ul> |
|---|---|

Specification Information		
• Dimension W	• Style Number	• U.S. Price

• Dimension W	• Style Number	• U.S. Price
56"	TSTECHM	\$25



### For Canadian Pricing

Multiply U.S. Price by the Canadian price factor.

▶ See page 1 for details.

Worksurface-Height Power and Communication Accessories, continued

**Mesh Cable Bag**

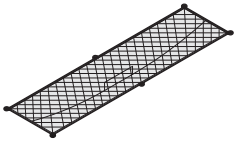

*Tip: Mesh cable bag is most effective when stretched to the full 48" during installation.*

Standard Includes	Required to Specify
<ul style="list-style-type: none"> <li>▶ Need help? Product details, page 77</li> <li>• Mesh cable bag</li> <li>• Attachment hardware</li> </ul>	<ul style="list-style-type: none"> <li>Style number</li> </ul>

Related Products	
<ul style="list-style-type: none"> <li>• Worksurfaces</li> <li>• Shelves</li> </ul>	<ul style="list-style-type: none"> <li>▶ Pages 107–110</li> <li>▶ Page 115</li> </ul>

Specification Information			
• Dimension	• Style	• U.S.	
W L	Number	Price	
24" 48"	<b>TSTECB</b>	\$66	

**Worksurface Clamp-On Power and Data**

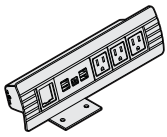

*Tip: Tour clamp-on accessories work on surfaces 3/4" to 1 1/4" thick. They do not work on surfaces over 1 1/4" thick.*

Standard Includes	Required to Specify
<ul style="list-style-type: none"> <li>▶ Need help? Product details, page 77</li> <li>• Worksurface-mounted power and data openings</li> <li>• 10' power cord with three-prong plug: black plastic</li> <li>• Four power receptacles, two data openings, and faceplates provided to accommodate customer-supplied voice/data jacks</li> <li>• Duplex receptacles: black plastic only</li> <li>• Surrounding housing: anodized aluminum</li> </ul>	<ul style="list-style-type: none"> <li>1 Style number</li> <li>2 Options, if selected (see below)</li> </ul>

Options	U.S. Price	Required to Specify
<b>Power/Data/USB Hub</b>		
• 2 power, 2 data, and 1 USB Hub	+\$ 83	Specify with 2 power + 2 data + 1 USB hub.
• 3 power, 1 data, and 1 USB Hub	+\$111	Specify with 3 power + 1 data + 1 USB hub.

Related Products	
<ul style="list-style-type: none"> <li>• Counters</li> <li>• Powerways</li> </ul>	<ul style="list-style-type: none"> <li>▶ Page 90</li> <li>▶ Page 94</li> </ul>

Specification Information	
• Style	• U.S.
Number	Base
:	Price
<b>TSTECLAMP</b>	\$389



**For Canadian Pricing**  
 Multiply U.S. Price by the Canadian price factor.  
 ▶ See page 1 for details.

## Worksurface-Mounted Retractable Power and Data

Field-Installed Cut-Out

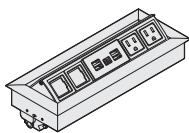

*Tip: Worksurface-mounted retractable power and data requires a 4" x 11" hole with square corners in the worksurface.*

Standard Includes	Required to Specify
-------------------	---------------------

<ul style="list-style-type: none"> <li>▶ Need help? Product details, page 76</li> </ul>	<ul style="list-style-type: none"> <li>• Worksurface-mounted power and data openings</li> <li>• 10' power cord with three-prong plug: black plastic</li> <li>• Four power receptacles, two data openings, and faceplates provided to accommodate customer-supplied voice/data jacks</li> <li>• Duplex receptacles: black plastic only</li> <li>• Surrounding housing: anodized aluminum</li> </ul>	<ul style="list-style-type: none"> <li>1 Style number</li> <li>2 Options, if selected (see below)</li> </ul>
---	--	--

Options	U.S. Price	Required to Specify
---------	------------	---------------------

<b>Power/Data/USB Hub</b>	<ul style="list-style-type: none"> <li>• 2 power, 2 data, and 1 USB Hub +\$ 83</li> <li>• 3 power, 1 data, and 1 USB Hub +\$111</li> </ul>	<ul style="list-style-type: none"> <li>Specify with 2 power + 2 data + 1 USB hub</li> <li>Specify with 3 power + 1 data + 1 USB hub</li> </ul>
---------------------------	--	--

<b>Related Products</b>	<ul style="list-style-type: none"> <li>• Counters</li> <li>• Powerways</li> </ul>	<ul style="list-style-type: none"> <li>▶ Page 90</li> <li>▶ Page 94</li> </ul>
-------------------------	---	--

Specification Information		
---------------------------	--	--

Style Number	U.S. Base Price
TSTERPDWR	\$417

## Vertical Cord Cover



*Tip: There are three knock-outs in the 30" and 42" vertical wire managers (TSTECC30 and TSTECC42). The first and third are available to route Tour power jumpers and the second is standard Decora-size to fit data ports, approximately 1 3/8"W x 2 5/8"H (actual dimensions 1.310"W x 2.687"H).*

Standard Includes	Required to Specify
-------------------	---------------------

<ul style="list-style-type: none"> <li>• Vertical cord cover: paint price group 1</li> <li>• Attachment hardware</li> </ul>	<ul style="list-style-type: none"> <li>1 Style number</li> <li>2 Paint color number for vertical cord cover</li> <li>3 Options, if selected (see below)</li> <li>▶ See <i>Surface Materials</i>, page 128.</li> </ul>
---	---

Options	U.S. Price	Required to Specify
---------	------------	---------------------

<b>Surface Materials</b>	<ul style="list-style-type: none"> <li>• Paint price group 1 No cost</li> <li>• Paint price group 2 +\$16</li> </ul>	<ul style="list-style-type: none"> <li>Specify paint color number.</li> <li>Specify paint color number.</li> </ul>
--------------------------	--	--

<b>Related Products</b>	<ul style="list-style-type: none"> <li>• Counters</li> <li>• Vertical cord cover grommet insert</li> </ul>	<ul style="list-style-type: none"> <li>▶ Page 90</li> <li>▶ Page 104</li> </ul>
-------------------------	--	---

Specification Information			
---------------------------	--	--	--

Dimensions			Style Number	U.S. Base Price
D	W	H		
7/8"	2 3/4"	30"	TSTECC30	\$45
7/8"	2 3/4"	42"	TSTECC42	\$56

**For Canadian Pricing**  
Multiply U.S. Price by the Canadian price factor.  
▶ See page 1 for details.

### Vertical Cord Cover Grommet Insert



Standard Includes	Required to Specify
-------------------	---------------------

- |   |  |
|---|--|
| <ul style="list-style-type: none"> <li>• Package of 5 grommet inserts: plastic</li> </ul> | <ul style="list-style-type: none"> <li>1 Style number</li> <li>2 Plastic color number for grommet insert</li> <li>▶ See <i>Surface Materials</i>, page 128.</li> </ul> |
|---|--|

Related Products
------------------

- |   |  |
|---|--|
| <ul style="list-style-type: none"> <li>• Vertical cord cover</li> </ul> | <ul style="list-style-type: none"> <li>▶ Page 103</li> </ul> |
|---|--|

Specification Information	
• Style Number	• U.S. Price

• Style Number	• U.S. Price
<b>TSTEGC</b>	\$25
:	:
:	:



**For Canadian Pricing**  
 Multiply U.S. Price by the Canadian price factor.  
 ▶ See page 1 for details.

# Bench Components

## Bench Trough

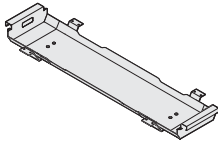

Standard Includes		Required to Specify
<ul style="list-style-type: none"> <li>▶ Need help? Product details, page 78</li> </ul>	<ul style="list-style-type: none"> <li>• Steel telescoping bench trough: paint price group 1</li> <li>• Attachment hardware</li> </ul>	<ul style="list-style-type: none"> <li>1 Style number</li> <li>2 Paint color number</li> <li>3 Options, if selected (see below)</li> <li>▶ See <i>Surface Materials</i>, page 128.</li> </ul>

Options	U.S. Price	Required to Specify
<b>Surface Materials</b> <ul style="list-style-type: none"> <li>• Paint price group 1</li> <li>• Paint price group 2</li> </ul>	No cost +\$43	Specify paint color number. Specify paint color number.

<b>Related Products</b> <ul style="list-style-type: none"> <li>• Worksurfaces</li> </ul>	▶ Pages 107–110
--	-----------------

Specification Information				
Dimensions			Style Number	U.S. Base Price
D	W	L		
43/8"	12"	60"–72"	<b>TSTECBT</b>	\$668

## Bench Screen

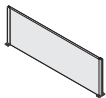

Standard Includes		Required to Specify
<ul style="list-style-type: none"> <li>▶ Need help? Product details, page 78</li> </ul>	<ul style="list-style-type: none"> <li>• Steel bench screen: paint price group 1</li> <li>• Attachment hardware</li> </ul>	<ul style="list-style-type: none"> <li>1 Style number</li> <li>2 Paint color number</li> <li>3 Options, if selected (see below)</li> <li>▶ See <i>Surface Materials</i>, page 128.</li> </ul>

Options	U.S. Price	Required to Specify
<b>Surface Materials</b> <ul style="list-style-type: none"> <li>• Paint price group 1</li> <li>• Paint price group 2</li> </ul>	No cost +\$43	Specify paint color number. Specify paint color number.

<b>Related Products</b> <ul style="list-style-type: none"> <li>• Worksurfaces</li> </ul>	▶ Pages 107–110
--	-----------------

Specification Information			
Dimensions		Style Number	U.S. Base Price
W	H		
48"	22"	<b>TSTECBDP</b>	\$445

 **For Canadian Pricing**  
 Multiply U.S. Price by the Canadian price factor.  
 ▶ See page 1 for details.

# SOTO Tour Rails

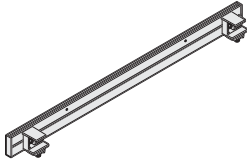

*Tip: Allow 1" clearance between worksurface and rail for cable management. Allow 2" for rail mount installed behind a worksurface, and 3¾" overall to install the rail.*

*Tip: Maximum weight load rails are 2 pounds per linked inch.*

*Tip: Each clamp requires a 2" footprint above the worksurface, and a 3¼" clearance below the worksurface.*

*Tip: Tour rails clamp to Tour bench troughs. Rails are not applicable for glass surfaces.*

Standard Includes	Required to Specify
-------------------	---------------------

- |   |              |
|---|--------------|
| <ul style="list-style-type: none"> <li>• Rail: 4799 Platinum</li> </ul> | Style number |
|---|--------------|

Related Products
------------------

- |  |  |
|--|--|
| <ul style="list-style-type: none"> <li>• SOTO shelves</li> <li>• SOTO worktools</li> </ul> | <ul style="list-style-type: none"> <li>▶ Page 286</li> <li>▶ Pages 283–110283</li> </ul> |
|--|--|

Specification Information					
---------------------------	--	--	--	--	--

Corresponding Table Top Width	Dimensions			Style Number	U.S. Price
D	W	H			
60"	1"	52"	3¼"	<b>DSRT52</b>	\$245
66"	1"	58"	3¼"	<b>DSRT58</b>	\$257
72"	1"	64"	3¼"	<b>DSRT64</b>	\$270
:	:	:	:	:	:



**For Canadian Pricing**  
 Multiply U.S. Price by the Canadian price factor.  
 ▶ See page 1 for details.

# Straight Worksurfaces

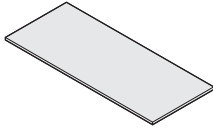

Standard Includes		Required to Specify
<ul style="list-style-type: none"> <li>▶ Need help? Product details, page 79</li> </ul>	<ul style="list-style-type: none"> <li>• 1 1/8"-thick worksurface: Low-Pressure Laminate or High-Pressure Laminate</li> <li>• 3 mm radius profile edge on both user's edges: plastic</li> <li>• 1 mm side edges: plastic default to match user's edges</li> <li>• Shipped ready to install</li> </ul>	<ol style="list-style-type: none"> <li>1 Style number</li> <li>2 Low-Pressure Laminate or High-Pressure Laminate color number for worksurface</li> <li>3 Plastic edge band color number for worksurface</li> <li>4 Options, if selected (see below)</li> </ol> <ul style="list-style-type: none"> <li>▶ See <i>Surface Materials</i>, page 128</li> </ul>

Options	U.S. Price	Required to Specify
<b>Surface Materials</b> <ul style="list-style-type: none"> <li>• High-Pressure Laminate worksurfaces</li> <li>• Open Line laminate</li> </ul>	+\$67 plus cost of laminate	<ul style="list-style-type: none"> <li>▶ See <i>Surface Materials Reference Manual</i>.</li> </ul>
<b>Related Products</b> <ul style="list-style-type: none"> <li>• Worksurface supports</li> <li>• Modesty panels</li> <li>• Reinforcing channel</li> </ul>		<ul style="list-style-type: none"> <li>▶ Pages 112–114</li> <li>▶ Page 116</li> <li>▶ Page 114</li> </ul>

*Tip: Reinforcing channel (TSATRC39, TSATRC48, TSATRC57, or TSATRC72) is required to add support to worksurfaces that have 60" or more of unsupported kneespace.*  
 ▶ Page 114

*Tip: Standard worksurfaces are 1 1/8" thick. However, the actual thickness between Low-Pressure Laminate (LPL) and High-Pressure Laminate (HPL) worksurfaces is slightly different. It is recommended that only worksurfaces of the same type are specified in a given application. In addition, there may be sheen or texture differences when using LPL and HPL in adjacent applications. Please use caution when mixing and matching different worksurface types.*

Specification Information					
Dimensions	Style Number	U.S. Price	Style Number	U.S. Base Price	
D	W		HPL		

Worksurfaces					
D	W	Style Number	U.S. Price	Style Number	U.S. Base Price
18"	42"	<b>TSTWLR1842</b>	\$142	<b>TSTWHR1842</b>	\$192
18"	48"	<b>TSTWLR1848</b>	\$155	<b>TSTWHR1848</b>	\$205
18"	54"	<b>TSTWLR1854</b>	\$185	<b>TSTWHR1854</b>	\$235
24"	36"	<b>TSTWLR2436</b>	\$138	<b>TSTWHR2436</b>	\$188
24"	42"	<b>TSTWLR2442</b>	\$151	<b>TSTWHR2442</b>	\$201
24"	48"	<b>TSTWLR2448</b>	\$173	<b>TSTWHR2448</b>	\$223
24"	54"	<b>TSTWLR2454</b>	\$202	<b>TSTWHR2454</b>	\$252
24"	60"	<b>TSTWLR2460</b>	\$217	<b>TSTWHR2460</b>	\$267
24"	66"	<b>TSTWLR2466</b>	\$247	<b>TSTWHR2466</b>	\$297
24"	72"	<b>TSTWLR2472</b>	\$256	<b>TSTWHR2472</b>	\$306
30"	60"	<b>TSTWLR3060</b>	\$261	<b>TSTWHR3060</b>	\$308
30"	66"	<b>TSTWLR3066</b>	\$272	<b>TSTWHR3066</b>	\$316
30"	72"	<b>TSTWLR3072</b>	\$279	<b>TSTWHR3072</b>	\$329

Tour Workspace

 **For Canadian Pricing**  
 Multiply U.S. Price by the Canadian price factor.  
 ▶ See page 1 for details.

# Tapered Worksurfaces

*Tip: Reinforcing channel (TSATRC39, TSATRC48, TSATRC57, or TSATRC72) is required to add support to worksurfaces that have 60" or more of unsupported kneespace.*  
 ▶ Page 114

*Tip: Standard worksurfaces are 1 1/8" thick. However, the actual thickness between Low-Pressure Laminate (LPL) and High-Pressure Laminate (HPL) worksurfaces is slightly different. It is recommended that only worksurfaces of the same type are specified in a given application. In addition, there may be sheen or texture differences when using LPL and HPL in adjacent applications. Please use caution when mixing and matching different worksurface types.*

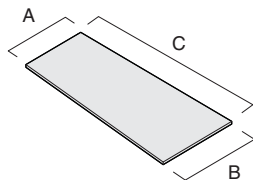
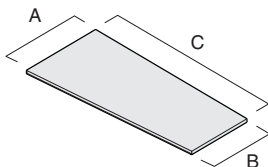

Standard Includes	Required to Specify
<ul style="list-style-type: none"> <li>▶ Need help? Product details, page 79</li> <li>• 1 1/8"-thick worksurface: Low-Pressure Laminate or High-Pressure Laminate</li> <li>• 3 mm radius profile edge on tapered edge: plastic</li> <li>• 1 mm side and back edges: plastic default to match tapered edge</li> <li>• Shipped ready to install</li> </ul>	<ol style="list-style-type: none"> <li>1 Style number</li> <li>2 Low-Pressure Laminate or High-Pressure Laminate color number for worksurface</li> <li>3 Plastic edge band color number for worksurface</li> <li>4 Options, if selected (see below)</li> </ol> ▶ See <i>Surface Materials</i> , page 128

Surface Materials	Options	U.S. Price	Required to Specify
	<b>High-Pressure Laminate worksurfaces</b> <ul style="list-style-type: none"> <li>• Open Line laminate</li> </ul>	+\$67 plus cost of laminate	▶ See <i>Surface Materials Reference Manual</i> .
<b>Related Products</b>	<ul style="list-style-type: none"> <li>• Worksurface supports</li> <li>• Modesty panels</li> <li>• Reinforcing channel</li> </ul>		▶ Pages 112–114 ▶ Page 116 ▶ Page 114

Specification Information						
Dimensions			Style	U.S.	Style	U.S.
A	B	C	Number LPL	Price	Number HPL	Base Price

## Left-Hand Worksurfaces

30"	24"	48"	<b>TSTWLT3248</b>	\$369	<b>TSTWHT3248</b>	\$425
30"	24"	54"	<b>TSTWLT3254</b>	\$394	<b>TSTWHT3254</b>	\$458
30"	24"	60"	<b>TSTWLT3260</b>	\$416	<b>TSTWHT3260</b>	\$490
30"	24"	66"	<b>TSTWLT3266</b>	\$443	<b>TSTWHT3266</b>	\$525
30"	24"	72"	<b>TSTWLT3272</b>	\$472	<b>TSTWHT3272</b>	\$563

## Right-Hand Worksurfaces

24"	30"	48"	<b>TSTWLT2348</b>	\$369	<b>TSTWHT2348</b>	\$425
24"	30"	54"	<b>TSTWLT2354</b>	\$394	<b>TSTWHT2354</b>	\$458
24"	30"	60"	<b>TSTWLT2360</b>	\$416	<b>TSTWHT2360</b>	\$490
24"	30"	66"	<b>TSTWLT2366</b>	\$443	<b>TSTWHT2366</b>	\$525
24"	30"	72"	<b>TSTWLT2372</b>	\$472	<b>TSTWHT2372</b>	\$563



**For Canadian Pricing**  
 Multiply U.S. Price by the Canadian price factor.  
 ▶ See page 1 for details.

# 120° Corner Worksurfaces

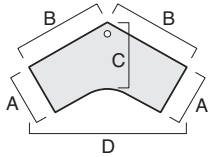
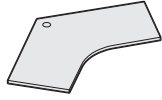

Standard Includes		Required to Specify
<ul style="list-style-type: none"> <li>▶ Need help? Product details, page 79</li> </ul>	<ul style="list-style-type: none"> <li>• 1 1/8"–thick worksurface: Low-Pressure Laminate or High-Pressure Laminate</li> <li>• 3 mm radius profile edge on user's side: plastic</li> <li>• Grommet: black plastic only</li> <li>• Shipped ready to install</li> </ul>	<ol style="list-style-type: none"> <li>1 Style number</li> <li>2 Low-Pressure Laminate or High-Pressure Laminate color number for worksurface</li> <li>3 Plastic edge band color number for worksurface</li> <li>4 Options, if selected (see below)</li> </ol> <p>▶ See <i>Surface Materials</i>, page 128</p>

Options	U.S. Price	Required to Specify
<b>Surface Materials</b> • High-Pressure Laminate worksurfaces • Open Line laminate	+\$67 plus cost of laminate	▶ See <i>Surface Materials Reference Manual</i> .
<b>Related Products</b> • Worksurface supports • Modesty panels		▶ Pages 112–114 ▶ Page 116

Specification Information					
Dimensions				Style Number	U.S. Base Price
A	B	C	D		

Low-Pressure Laminate Worksurfaces					
24"	36"	30 1/2"	63 11/32"	<b>TSTWLY2436</b>	\$469
24"	42"	30 1/2"	72 3/4"	<b>TSTWLY2442</b>	\$503
24"	48"	30 1/2"	85 5/32"	<b>TSTWLY2448</b>	\$554

High-Pressure Laminate Worksurfaces					
24"	36"	30 1/2"	63 11/32"	<b>TSTWHY2436</b>	\$519
24"	42"	30 1/2"	72 3/4"	<b>TSTWHY2442</b>	\$553
24"	48"	30 1/2"	85 5/32"	<b>TSTWHY2448</b>	\$604

**120° Corner Worksurfaces**

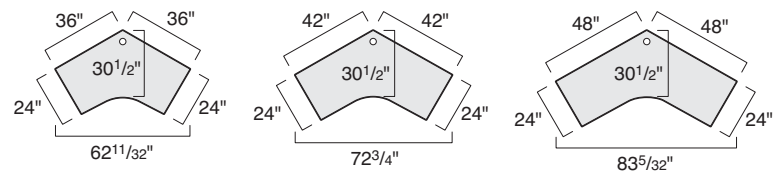

 **For Canadian Pricing**  
 Multiply U.S. Price by the Canadian price factor.  
 ▶ See page 1 for details.

# Round Worksurfaces

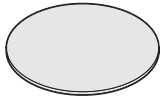

*Tip: Standard worksurfaces are 1 1/8" thick. However, the actual thickness between Low-Pressure Laminate (LPL) and High-Pressure Laminate (HPL) worksurfaces is slightly different. It is recommended that only worksurfaces of the same type are specified in a given application. In addition, there may be sheen or texture differences when using LPL and HPL in adjacent applications. Please use caution when mixing and matching different worksurface types.*

Standard Includes	Required to Specify
<ul style="list-style-type: none"> <li>▶ Need help? Product details, page 79</li> <li>• 1 1/8"-thick worksurface: Low-Pressure Laminate or High-Pressure Laminate</li> <li>• 3 mm radius profile edge: plastic</li> <li>• Shipped ready to install</li> </ul>	<ol style="list-style-type: none"> <li>1 Style number</li> <li>2 Low-Pressure Laminate or High-Pressure Laminate color number for worksurface</li> <li>3 Plastic edge band color number for worksurface</li> <li>4 Options, if selected (see below)</li> </ol> <ul style="list-style-type: none"> <li>▶ See <i>Surface Materials</i>, page 128</li> </ul>

Options	U.S. Price	Required to Specify
<b>Surface Materials</b> <ul style="list-style-type: none"> <li>• High-Pressure Laminate worksurfaces</li> <li>• Open Line laminate</li> </ul>	<ul style="list-style-type: none"> <li>• +\$67 plus cost of laminate</li> </ul>	<ul style="list-style-type: none"> <li>▶ See <i>Surface Materials Reference Manual</i>.</li> </ul>
<b>Related Products</b> <ul style="list-style-type: none"> <li>• Post legs</li> <li>• Groupwork round table bases</li> <li>• Floating round worksurface support</li> </ul>		<ul style="list-style-type: none"> <li>▶ Page 113</li> <li>▶ Page 113</li> <li>▶ Page 114</li> </ul>

Specification Information				
• Dimensions	• Style	• U.S.	• Style	• U.S.
Diameter	Number	Price	Number	Base
:	LPL	:	HPL	Price
:	:	:	:	:
30"	<b>TSTWLDLR30</b>	\$251	<b>TSTWHDR30</b>	\$289
36"	<b>TSTWLDLR36</b>	\$293	<b>TSTWHDR36</b>	\$321
:	:	:	:	:



**For Canadian Pricing**  
 Multiply U.S. Price by the Canadian price factor.  
 ▶ See page 1 for details.



# Worksurface Supports

*Tip: Worksurface frame supports must have one end attached to a shelf, counter or a support on the opposite end such as a laminate worksurface frame support or post legs. Worksurface frame supports cannot support both ends of a freestanding worksurface.*

	Standard Includes	Required to Specify
<ul style="list-style-type: none"> <li>▶ Need help? Product details, page 80</li> </ul>	<ul style="list-style-type: none"> <li>• Worksurface frame supports: paint price group 1</li> <li>• Post legs: paint</li> <li>• Table bases: paint</li> <li>• Laminate worksurface frame support: Low-Pressure Laminate with matching plastic edge band</li> <li>• Tapered leg: paint</li> <li>• Tie plates: black only</li> <li>• Floating round worksurface support: black only</li> <li>• Leveling glides</li> <li>• Attachment hardware</li> <li>• Shipped ready to install</li> </ul>	<ol style="list-style-type: none"> <li>1 Style number</li> <li>2 Paint color number for worksurface frame supports, post legs, tapered legs, and tables bases</li> <li>3 Low-Pressure Laminate color number for worksurface frame supports</li> <li>4 Options, if selected (see below)</li> </ol> <p>▶ See <i>Surface Materials</i>, page 128.</p>

	Options	U.S. Price	Required to Specify
<b>Surface Materials</b>	<b>Worksurface frame supports</b>		
	• Paint price group 1	No cost	Specify paint color number.
	• Paint price group 2	+\$29	Specify paint color number.
	<b>Post legs</b>		
	• Paint price group 1	No cost	Specify paint color number.
	• Paint price group 2	+\$10 per leg	Specify paint color number.
	<b>Table bases</b>		
	• Paint price group 1	No cost	Specify paint color number.
	• Paint price group 2	+\$29	Specify paint color number.
<b>Casters</b>	<b>One post or standing-height table leg</b>		
	• One locking caster	+\$ 5	Specify <i>with caster</i> .
<b>Pin Height-Adjustable Legs</b>	• One post leg	+\$51	Specify <i>with pin height-adjustable leg</i> .
<b>Related Products</b>	<ul style="list-style-type: none"> <li>• Worksurfaces</li> <li>• Shelves</li> <li>• My file</li> </ul>		<ul style="list-style-type: none"> <li>▶ Pages 107–110</li> <li>▶ Page 115</li> <li>▶ Pages 122–123</li> </ul>

Specification Information			
Dimensions	Style	U.S.	
D H	Number	Base Price	

Worksurface Frame Supports			
18"	15"	<b>TSTTF1518</b>	\$178
24"	27"	<b>TSTTF2724</b>	\$289
30"	27"	<b>TSTTF2730</b>	\$311

Laminate Worksurface Supports			
24"	27"	<b>TSTTL2724</b>	\$289
30"	27"	<b>TSTTL2730</b>	\$311

▶ **Specification Information, continued on next page**

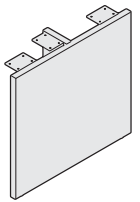
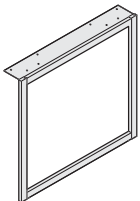

 **For Canadian Pricing**  
 Multiply U.S. Price by the Canadian price factor.  
 ▶ See page 1 for details.

► Specification Information, continued from previous page

**Specification Information**

• Dimensions		• Style	• U.S.
H	Dia	Number	Base Price



<b>One Post Leg</b>			
27 <sup>3</sup> / <sub>8</sub> "		<b>TS4L27PG</b>	\$106



<b>One Standing-Height Adjustable Post Leg</b>			
27 <sup>3</sup> / <sub>8</sub> "–44"		<b>TS4LSHPG</b>	\$188



<b>Tapered Leg</b>			
27 <sup>3</sup> / <sub>8</sub> "		<b>TSTT27M</b>	\$134

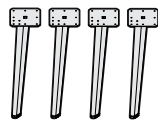

<b>Package of Four Tapered Legs</b>			
27 <sup>3</sup> / <sub>8</sub> "		<b>TSTT27M4</b>	\$472

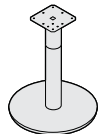

<b>Adjustable Round Table Base</b>			
27 <sup>3</sup> / <sub>8</sub> "	18"	<b>TSTTT27</b>	\$373

Tip: Adjustability range is 3<sup>1</sup>/<sub>2</sub>".  
 Tip: Tour adjustable round table bases are not approved for freestanding applications. Round table bases are intended to be used at one end of a worksurface that is attached to a Tour counter. For freestanding applications see Groupwork round table bases in the Meeting Spaces Specification Guide.

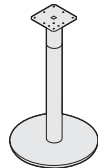

<b>Café-Height Adjustable Round Table Base</b>			
41"	18"	<b>TSTTT39</b>	\$397

► Specification Information, continued on next page

Tour Workspace

Worksurface Supports, continued

► Specification Information, continued from previous page

**Specification Information**

• Dimensions		• Style	• U.S.
H	Dia	Number	Base Price



Tip: Two sets of tie plates are required if worksurface is attached parallel to the counter.

**Pair of Counter-to-Worksurface Tie Plates**

		<b>TSTTPC2W</b>	\$101
--	--	-----------------	-------



Tip: Two sets of tie plates are required if worksurface is attached parallel to the shelf.

**Pair of Shelf-to-Worksurface Tie Plates**

		<b>TSTTPS2W</b>	\$ 41
--	--	-----------------	-------

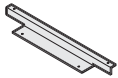

**Counter Frame-to-Worksurface Tie Plate**

		<b>TSTTPF2W</b>	\$ 94
--	--	-----------------	-------



**Floating Round Worksurface Support**

		<b>TSTTTZD</b>	\$ 56
--	--	----------------	-------

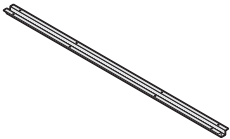

**Reinforcing Channels**

39"W		<b>TSATRC39</b>	\$ 46
48"W		<b>TSATRC48</b>	\$ 49
57"W		<b>TSATRC57</b>	\$ 49
72"W		<b>TSATRC72</b>	\$112

**Flip Grommet**

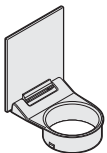

Tip: Flip grommet requires a 3" diameter hole in the worksurface.

Standard Includes	Required to Specify
<ul style="list-style-type: none"> <li>• Flip cover: paint</li> <li>• Bottom grommet portion: black plastic</li> </ul>	<ul style="list-style-type: none"> <li>1 Style number</li> <li>2 Paint color number for flip cover</li> <li>► See <i>Surface Materials</i>, page 128.</li> </ul>

**Specification Information**

• Dimensions			• Style	• U.S.
D	W	H	Number	Price

4 1/2"	4"	1 3/4"	<b>TS5GF3</b>	\$59
--------	----	--------	---------------	------



**For Canadian Pricing**  
 Multiply U.S. Price by the Canadian price factor.  
 ► See page 1 for details.

# Shelves

*Tip: Standard worksurfaces are 1 1/8" thick. However, the actual thickness between Low-Pressure Laminate (LPL) and High-Pressure Laminate (HPL) worksurfaces is slightly different. It is recommended that only worksurfaces of the same type are specified in a given application. In addition, there may be sheen or texture differences when using LPL and HPL in adjacent applications. Please use caution when mixing and matching different worksurface types.*

Standard Includes		Required to Specify
▶ Need help? Product details, page 79	<ul style="list-style-type: none"> <li>• 1 1/8"-thick shelf: Low-Pressure Laminate or High-Pressure Laminate</li> <li>• 3 mm radius profile edge: plastic</li> <li>• Shelf-to-counter attachment hardware: 4799 Platinum</li> <li>• Cutout for vertical cord cover</li> <li>• Shipped ready to install</li> </ul>	<ol style="list-style-type: none"> <li>1 Style number</li> <li>2 Low-Pressure Laminate or High-Pressure Laminate color number for shelf</li> <li>3 Plastic edge band color number for shelf</li> <li>4 Options, if selected (see below)</li> </ol> <p>▶ See <i>Surface Materials</i>, page 128.</p>

Options	U.S. Price	Required to Specify
<b>Surface Materials</b> • High-Pressure Laminate worksurfaces • Open Line laminate	+ \$67 plus cost of laminate	▶ See <i>Surface Materials Reference Manual</i> .
<b>Related Products</b> • Counters • Post legs		▶ Page 90 ▶ Page 113

Specification Information					
Dimensions		Style Number	U.S. Price	Style Number	U.S. Base Price
D	W	LPL		HPL	

Shelves					
9"	70"	<b>TSTMLF0970</b>	\$200	<b>TSTMHF0970</b>	\$250
21"	70"	<b>TSTMLF2170</b>	\$294	<b>TSTMHF2170</b>	\$344
33"	70"	<b>TSTMLF3370</b>	\$342	<b>TSTMHF3370</b>	\$392
:	:	:	:	:	:

Corner Shelves					
Left-Hand Corner Shelves					
45"	70"	<b>TSTMLF4570L</b>	\$301	<b>TSTMHF4570L</b>	\$351
Right-Hand Corner Shelves					
45"	70"	<b>TSTMLF4570R</b>	\$301	<b>TSTMHF4570R</b>	\$351
:	:	:	:	:	:

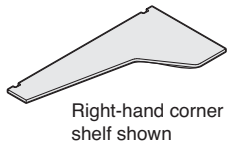
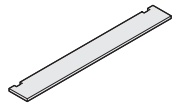

Right-hand corner shelf shown

*Tip: Corner shelf requires one post leg for support.*

*Tip: 21"D and 33"D rectangular shelves and corner shelves require additional support of a post leg or end support.*

▶ See page 79

**For Canadian Pricing**  
Multiply U.S. Price by the Canadian price factor.  
▶ See page 1 for details.

# Modesty Panels

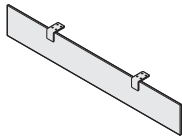

Tip: Modesty panel is 6" shorter from each side of worksurface.

Standard Includes	Required to Specify
<ul style="list-style-type: none"> <li>• Modesty panel: Low-Pressure Laminate with matching polypropylene edge band</li> <li>• Brackets: paint price group 1</li> <li>• Attachment hardware: black</li> <li>• Shipped ready to install</li> </ul>	<ol style="list-style-type: none"> <li>1 Style number</li> <li>2 Low-Pressure Laminate color number for modesty panel</li> <li>3 Paint color number for brackets</li> <li>4 Options, if selected (see below)</li> </ol> <p>▶ See <i>Surface Materials</i>, page 128.</p>

Options	U.S. Price	Required to Specify
<b>Surface Materials</b> <ul style="list-style-type: none"> <li>• Paint price group 1</li> <li>• Paint price group 2</li> </ul>	No cost +\$16	Specify paint color number. Specify paint color number.

Specification Information				
• Dimensions		• Corresponding Table Top Width	• Style Number	• U.S. Base Price
W	H			
30"	12"	42"	<b>TSTWMP1242</b>	\$202
36"	12"	48"	<b>TSTWMP1248</b>	\$216
42"	12"	54"	<b>TSTWMP1254</b>	\$230
48"	12"	60"	<b>TSTWMP1260</b>	\$243
54"	12"	66"	<b>TSTWMP1266</b>	\$256
60"	12"	72"	<b>TSTWMP1272</b>	\$271
:	:	:	:	:



**For Canadian Pricing**  
 Multiply U.S. Price by the Canadian price factor.  
 ▶ See page 1 for details.

## Screens

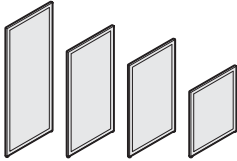

Tip: Screens attach easily to counters.

Tip: Screen connectors are sold separately.

Standard Includes	Required to Specify
<ul style="list-style-type: none"> <li>▶ Need help? Product details, page 82</li> <li>• Frame: Clear Anodized Aluminum</li> <li>• Infill: Low-Pressure Laminate</li> <li>• Adjustable leveling glides</li> <li>• Shipped ready to install</li> </ul>	<ul style="list-style-type: none"> <li>1 Style number</li> <li>2 Low-Pressure Laminate color number for screens</li> <li>▶ See <i>Surface Materials</i>, page 128.</li> </ul>

Related Products
<ul style="list-style-type: none"> <li>• Screen connectors</li> <li>• Counters</li> </ul>

Specification Information				
• Dimensions			• Style	• U.S.
D	W	H	Number	Price

Screens				
D	W	H	Style Number	U.S. Price
1"	24"	30"	<b>TSTPL3024</b>	\$240
1"	30"	30"	<b>TSTPL3030</b>	\$257
1"	36"	30"	<b>TSTPL3036</b>	\$306
1"	42"	30"	<b>TSTPL3042</b>	\$312
1"	48"	30"	<b>TSTPL3048</b>	\$325
1"	24"	42"	<b>TSTPL4224</b>	\$288
1"	30"	42"	<b>TSTPL4230</b>	\$312
1"	36"	42"	<b>TSTPL4236</b>	\$373
1"	42"	42"	<b>TSTPL4242</b>	\$386
1"	48"	42"	<b>TSTPL4248</b>	\$411
1"	24"	48"	<b>TSTPL4824</b>	\$312
1"	30"	48"	<b>TSTPL4830</b>	\$325
1"	36"	48"	<b>TSTPL4836</b>	\$386
1"	42"	48"	<b>TSTPL4842</b>	\$411
1"	48"	48"	<b>TSTPL4848</b>	\$435
1"	24"	60"	<b>TSTPL6024</b>	\$331
1"	30"	60"	<b>TSTPL6030</b>	\$386
1"	36"	60"	<b>TSTPL6036</b>	\$411
1"	42"	60"	<b>TSTPL6042</b>	\$490
1"	48"	60"	<b>TSTPL6048</b>	\$533

 **For Canadian Pricing**  
 Multiply U.S. Price by the Canadian price factor.  
 ▶ See page 1 for details.

**Screens Connectors**

Standard Includes	Required to Specify
<ul style="list-style-type: none"> <li>Need help? Product details, page 82</li> <li>Screen connectors: 4799 Platinum paint</li> </ul>	Style number

Related Products
<ul style="list-style-type: none"> <li>Screens</li> <li>Worksurfaces</li> </ul>

**Specification Information**

Style Number	U.S. Price

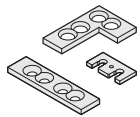

**Inline and L, Same Height Screen Connector**

<b>TSTPBSH2</b>	\$31

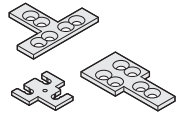

**T, Same Height Screen Connector**

<b>TSTPBSH3</b>	\$45

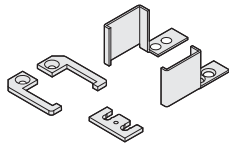

**Inline and L, Change-of-Height Screen Connectors**

<b>TSTPBCOH2</b>	\$31

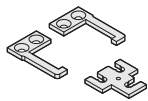

**T, Change-of-Height Screen Connectors**

<b>TSTPBCOH3</b>	\$45

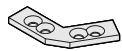

**120° Two-Way, Same Height Screen Connector**

<b>TSTPB120</b>	\$46



**120° Three-Way, Same Height Screen Connector**

<b>TSTPB120Y</b>	\$51

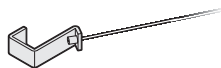

**Worksurface-to-Screen Tie**

<b>TSTPBWT</b>	\$56



**For Canadian Pricing**  
 Multiply U.S. Price by the Canadian price factor.  
 ▶ See page 1 for details.

# HV Cabinet

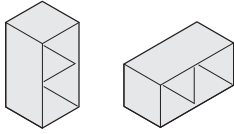

Tip: Laminate grain direction on doors runs vertical when cabinet is horizontal.

Tip: Pull paint color number is required when door option is selected.  
 ▶ Page 128

Standard Includes		Required to Specify
-------------------	--	---------------------

▶ Need help? Product details, page 86	<ul style="list-style-type: none"> <li>Steel cabinet and shelf: paint price group 1</li> <li>Center divider: laminate color to complement cabinet</li> <li>Shipped fully assembled</li> </ul>	1 Style number 2 Paint color number for cabinet and shelf 3 Options, if selected (see below) ▶ See <i>Surface Materials</i> , page 128.
---------------------------------------	---	--

Options	U.S. Price	Required to Specify
---------	------------	---------------------

<b>Surface Materials</b>	<b>Steel cabinet and shelf</b>		
	<ul style="list-style-type: none"> <li>Paint price group 1</li> <li>Paint price group 2</li> </ul>	No cost +\$43	Specify paint color number. Specify paint color number.
	<b>Pulls</b>		
	<ul style="list-style-type: none"> <li>Paint price group 1</li> <li>Paint price group 2</li> </ul>	No cost +\$ 5 per door	Specify paint color number. Specify paint color number.
<b>Doors</b>	<b>Laminate</b>		
	<ul style="list-style-type: none"> <li>One laminate sliding door</li> <li>Two laminate sliding doors</li> </ul>	+\$33 +\$66	Specify <i>with one laminate sliding door</i> . Specify <i>with two laminate sliding doors</i> .
<b>Related Products</b>	<ul style="list-style-type: none"> <li>Counters</li> <li>Pile file</li> <li>Markerboards</li> </ul>		▶ Page 90 ▶ Page 124 ▶ Page 125

### Specification Information

Dimensions			Style Number	U.S. Base Price
D	W	H		
18"	18"	36"	<b>TSTSCHV36</b>	\$423

Tour Workspace

 **For Canadian Pricing**  
 Multiply U.S. Price by the Canadian price factor.  
 ▶ See page 1 for details.

# Shared HV Cabinet

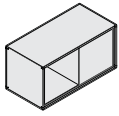

Standard Includes		Required to Specify
<ul style="list-style-type: none"> <li>▶ Need help? Product details, page 86</li> </ul>	<ul style="list-style-type: none"> <li>• Steel cabinet and center divider: paint price group 1</li> <li>• Non-locking</li> <li>• Shipped fully assembled</li> </ul>	<ol style="list-style-type: none"> <li>1 Style number</li> <li>2 Paint color number for cabinet and center divider</li> <li>3 Options, If selected (see below)                             <ul style="list-style-type: none"> <li>▶ See <i>Surface Materials</i>, page 128.</li> </ul> </li> </ol>

*Tip: Pull paint color number is required when door option is selected.*  
▶ Page 128

	Options	U.S. Price	Required to Specify
<b>Surface Materials</b>	<b>Steel cabinet</b>		
	<ul style="list-style-type: none"> <li>• Paint price group 1</li> <li>• Paint price group 2</li> </ul>	No cost +\$43	Specify paint color number. Specify paint color number.
	<b>Pulls</b>		
	<ul style="list-style-type: none"> <li>• Paint price group 1</li> <li>• Paint price group 2</li> </ul>	No cost +\$10	Specify paint color number. Specify paint color number.
<b>Doors</b>	<b>Laminate</b>		
	<ul style="list-style-type: none"> <li>• Two laminate sliding doors</li> </ul>	+\$66	Specify with two laminate sliding doors and indicate laminate color number. ▶ See <i>Surface Materials</i> , page 128.
<b>Related Products</b>	<ul style="list-style-type: none"> <li>• Magnetic markerboards</li> <li>• Magnetic tackboards</li> </ul>		▶ Page 125 ▶ Page 125

Specification Information				
Dimensions			Style Number	U.S. Base Price
D	W	H		
18"	18"	36"	<b>TTSCHVD36</b>	\$601



**For Canadian Pricing**  
Multiply U.S. Price by the Canadian price factor.  
▶ See page 1 for details.

# Bookcases

Standard Includes		Required to Specify
▶ Need help? Product details, page 87	<ul style="list-style-type: none"> <li>• Low-Pressure Laminate bookcase with matching polypropylene edge band</li> <li>• Two fixed shelves each side for shared bookcase</li> <li>• One fixed shelf for personal bookcase</li> <li>• Shipped fully assembled</li> </ul>	1 Style number 2 Low-Pressure Laminate color number for bookcase 3 Options, if selected (see below) ▶ See <i>Surface Materials</i> , page 128.

Options	U.S. Price	Required to Specify
<b>Legs</b>	• Legs for personal bookcase +\$56	Specify <i>with legs</i> .
<b>Related Products</b>	• Counters • Pile file	▶ Page 90 ▶ Page 124

*Tip: A personal bookcase can be specified with optional legs for use at the bottom of a counter.*

Specification Information		
Dimensions		
D	W	H
Style Number		
U.S. Base Price		

## Shared Bookcase

18"	18"	36"	<b>TSTSBS3618</b>	\$645
:	:	:	:	:

## Personal Bookcase

9"	18"	18"	<b>TSTSBP1818</b>	\$317
:	:	:	:	:

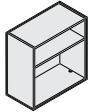
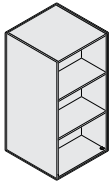

without legs (standard)

with legs (optional)

 **For Canadian Pricing**  
 Multiply U.S. Price by the Canadian price factor.  
 ▶ See page 1 for details.

# My File

Standard Includes		Required to Specify
<ul style="list-style-type: none"> <li>▶ Need help? Product details, page 88</li> </ul>	<ul style="list-style-type: none"> <li>• My file and drawer front: Low-Pressure Laminate</li> <li>• Steel drawer body: black only</li> <li>• File drawer to accommodate suspended side-to-side filing, and provides space in front of files for miscellaneous storage</li> <li>• Non-locking drawer</li> <li>• turnstone ledge pull: paint price group 1</li> <li>• Adjustable leveling glides</li> <li>• Shipped fully assembled</li> <li>• Attachment hardware</li> </ul>	<ol style="list-style-type: none"> <li>1 Style number</li> <li>2 Low-Pressure Laminate color number for file and drawer front</li> <li>3 Paint color number for turnstone ledge pull</li> <li>4 Options, if selected (see below)                             <ul style="list-style-type: none"> <li>▶ See <i>Surface Materials</i>, page 128.</li> <li><i>Tip: Remember to specify lock cylinder and key.</i></li> <li>▶ Lock cylinders, page 329</li> </ul> </li> </ol>

Options	U.S. Price	Required to Specify
<b>Surface Materials</b> <b>Pulls</b> <ul style="list-style-type: none"> <li>• Paint price group 1</li> <li>• Paint price group 2</li> </ul>	No cost +\$ 6	Specify paint color number. Specify paint color number.
<b>Drawer lock</b> <ul style="list-style-type: none"> <li>• Drawer lock: 9201 Polished Chrome</li> </ul>	+ \$114	Specify with <i>9201 Polished Chrome lock</i> .
<b>Related Products</b> <ul style="list-style-type: none"> <li>• Worksurfaces</li> </ul>		▶ Pages 107–110

*Tip: Remember to specify lock cylinder and key.*  
 ▶ Lock cylinders, page 329

## Specification Information

Dimensions			Style Number	U.S. Base Price
D	W	H		
24"	18"	15"	<b>TSTSFL1518</b>	\$ 668
24"	36"	15"	<b>TSTSFL1536</b>	\$1057

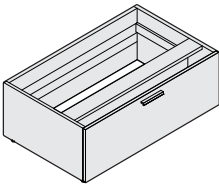
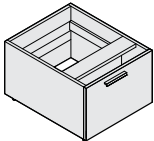

**For Canadian Pricing**  
 Multiply U.S. Price by the Canadian price factor.  
 ▶ See page 1 for details.

## Lateral File Cushion

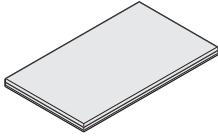

*Tip: Lateral file cushion can be installed on Tour coffee table height work-surface when attached to a Tour counter and above a my file on worksurface frame support.*

Standard Includes	Required to Specify
<ul style="list-style-type: none"> <li>▶ Need help? Product details, page 88</li> <li>Fully upholstered lateral file cushion:                             <ul style="list-style-type: none"> <li>fabric price group 1</li> <li>Hardware package to attach cushion to worksurface</li> <li>Meets Cal. 117 requirements</li> <li>Ships ready to assemble</li> </ul> </li> </ul>	<ul style="list-style-type: none"> <li>1 Style number</li> <li>2 Fabric color number for lateral file cushion</li> <li>3 Options, if selected (see below)                             <ul style="list-style-type: none"> <li>▶ See <i>Surface Materials</i>, page 247.</li> </ul> </li> </ul>

Options		U.S. Price	Required to Specify
<b>Surface Materials</b>	<b>Upholstery</b>		
	<ul style="list-style-type: none"> <li>Fabric price group 1</li> <li>Fabric price group 2</li> <li>Fabric price group 3</li> <li>Fabric price group 4</li> <li>Fabric price group 5</li> <li>Fabric price group 6</li> <li>Fabric price group 7</li> <li>Fabric price group 8</li> <li>Fabric price group 9</li> <li>Fabric price group 10</li> <li>Leather price group</li> </ul>	<ul style="list-style-type: none"> <li>No cost</li> <li>+\$ 25</li> <li>+\$ 47</li> <li>+\$ 66</li> <li>+\$ 83</li> <li>+\$103</li> <li>+\$118</li> <li>+\$149</li> <li>+\$183</li> <li>+\$208</li> <li>+\$520</li> </ul>	<ul style="list-style-type: none"> <li>Specify fabric color number.</li> <li>Specify fabric color number.</li> <li>Specify fabric color number.</li> <li>Specify fabric color number.</li> <li>Specify fabric color number.</li> <li>Specify fabric color number.</li> <li>Specify fabric color number.</li> <li>Specify fabric color number.</li> <li>Specify fabric color number.</li> <li>Specify fabric color number.</li> <li>Specify fabric color number.</li> <li>Add suffix <b>L</b> to style number and specify leather color number.</li> <li>▶ See <i>Understanding Customer's Own Material (COM)</i>, page 324</li> </ul>
	<ul style="list-style-type: none"> <li>Customer's Own Material (COM) or Customer's Own Leather (COL)</li> </ul>	<ul style="list-style-type: none"> <li>+\$ 36</li> </ul>	

Specification Information				
• Dimensions			• Style	• U.S.
D	W	H	Number	Base Price
24"	36"	2"	<b>TSTLATPAD</b>	\$281

Tour Workspace

**For Canadian Pricing**  
 Multiply U.S. Price by the Canadian price factor.  
 ▶ See page 1 for details.

# Pile File



Tip: Adding a markerboard increases the usability of the pile file's steel top and back.

Tip: Add an HV cabinet or bookcase to the top to add more storage space.

Tip: For legal size front-to-back filing, use 15" universal storage rail RXADRL15.

Tip: Remember to specify lock cylinder and key.

▶ Lock cylinders, page 329

Standard Includes		Required to Specify
▶ Need help? Product details, page 89	<ul style="list-style-type: none"> <li>Steel top, back, and fixed center shelf: paint price group 1</li> <li>Drawer front, sides and sliding shelves: Low-Pressure Laminate</li> <li>Drawer body: black only</li> <li>Drawer and shelf suspensions: black only</li> <li>turnstone ledge pull: paint price group 1</li> <li>Adjustable leveling glides</li> <li>Shipped fully assembled</li> </ul>	<ol style="list-style-type: none"> <li>Style number</li> <li>Paint color number for top, back, and fixed center shelf</li> <li>Low-Pressure Laminate color number for drawer front, sides, and sliding shelves</li> <li>Paint color number for turnstone ledge pull</li> <li>Options, if selected (see below)</li> </ol> <p>▶ See <i>Surface Materials</i>, page 128.</p>

Options	U.S. Price	Required to Specify
<b>Surface Materials</b> <b>Steel top, back, and fixed center shelf</b> <ul style="list-style-type: none"> <li>Paint price group 1</li> <li>Paint price group 2</li> </ul>	No cost +\$ 43	Specify paint color number. Specify paint color number.
<b>Pulls</b> <ul style="list-style-type: none"> <li>Paint price group 1</li> <li>Paint price group 2</li> </ul>	No cost +\$ 6	Specify paint color number. Specify paint color number.
<b>Drawer lock</b> <ul style="list-style-type: none"> <li>Drawer lock: 9201 Polished Chrome</li> </ul>	+\$114	Specify <i>with 9201 Polished Chrome lock</i> .
<b>Casters</b> <ul style="list-style-type: none"> <li>Casters</li> </ul>	+\$ 56	Specify <i>with casters</i> .
<b>Related Products</b> <ul style="list-style-type: none"> <li>Markerboards</li> <li>HV cabinets</li> </ul>		▶ Page 125 ▶ Pages 119–120

Specification Information				
Dimensions			Style Number	U.S. Base Price
D	W	H		
18"	36"	42"	<b>TSTSFP4236</b>	\$1168



**For Canadian Pricing**

Multiply U.S. Price by the Canadian price factor.

▶ See page 1 for details.

# Magnetic Markerboards and Tackboards

## Markerboards

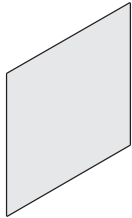

Tip: Makes a convenient markerboard on any steel surfaces.

Tip: Actual markerboard dimensions are 16 1/2" x 16 1/2" and 34" x 16 1/2" respectively. They are designed to fit within the 18" x 18" and 36" x 18" footprint of the HV Cabinets and Pile File.

Standard Includes	Required to Specify
<ul style="list-style-type: none"> <li>▶ Need help? Product details, page 86</li> <li>• Magnetic markerboard: 6650 Sodium</li> </ul>	Style number

Related Products
<ul style="list-style-type: none"> <li>• HV cabinets</li> <li>• Pile file</li> </ul>

Specification Information				
Dimensions			Style Number	U.S. Price
D	W	H		
1/8"	18"	18"	TSTSMB1818	\$ 56
1/8"	36"	18"	TSTSMB3618	\$111

## Tackboards

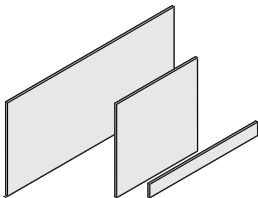

Tip: Actual tackboard dimensions are 16 1/2" x 16 1/2" and 34" x 16 1/2" respectively. They are designed to fit within the 18" x 18" and 36" x 18" footprint of the HV Cabinets and Pile File.

Standard Includes	Required to Specify
<ul style="list-style-type: none"> <li>▶ Need help? Product details, page 86</li> <li>• Magnetic tackboard: fabric price group A (Systems upholstery)</li> </ul>	<ol style="list-style-type: none"> <li>1 Style number</li> <li>2 Fabric color number for upholstery</li> <li>3 Options, if selected (see below)</li> </ol> <ul style="list-style-type: none"> <li>▶ See <i>Surface Materials</i>, page 128.</li> </ul>

Options	U.S. Price	Required to Specify
<b>Surface Materials</b>	<b>Standard Systems Upholstery</b>	
	• Fabric price group A	No cost
	• Fabric price group 1	+\$ 5
	<b>Standard Seating Upholstery</b>	
	• Fabric price group 1	+\$ 5
	• Fabric price group 2	+\$14
	• Fabric price group 3	+\$25
	<b>Designtex Seating Upholstery</b>	
	• Fabric price group 2	+\$14
	• Fabric price group 3	+\$25
	• Customer's Own Material (COM)	+\$36
		Specify fabric color number.
		▶ See <i>Understanding Customer's Own Material (COM)</i> , page 324

Specification Information			
Dimensions		Style Number	U.S. Base Price
W	H		
22"	2 1/2"	TSTSMT0322	\$106
18"	18"	TSTSMT1818	\$200
36"	18"	TSTSMT3618	\$311

 **For Canadian Pricing**  
 Multiply U.S. Price by the Canadian price factor.  
 ▶ See page 1 for details.

# Task Lights

## Underline Task Light

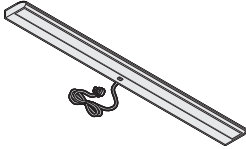

	Standard Includes	Required to Specify
<p>▶ Need help? See <i>Answer</i> <i>Specification Guide</i> for product details.</p>	<ul style="list-style-type: none"> <li>• Steel light housing: paint</li> <li>• Aluminum reflector</li> <li>• Batwing lens</li> <li>• Polycarbonate end caps: molded to match housing</li> <li>• Cords, 9' cord with three-prong plug at 90°/45° angle: black plastic only</li> <li>• Soft touch switch</li> <li>• Thin profile, energy-efficient T2 fluorescent lamp</li> <li>• Universal spring brackets for recessed mount and screw-in for flush mount</li> <li>• Tool free clips for New York application</li> </ul>	<ul style="list-style-type: none"> <li>1 Style number</li> <li>2 Paint color number for housing and end caps:                             <ul style="list-style-type: none"> <li>0835 Black</li> <li>7018 Pewter</li> <li>7021 Dark Champagne</li> </ul> </li> </ul>

Specification Information					
• Dimensions			• Lamp	• Style	• U.S.
D	W	H	Wattage	Number	Price
<b>Without Dimming</b>					
4¾"	22"	¾"	13 watts	<b>LT2</b>	\$281
<b>With Chicago Cord Including Circuit Breaker</b>					
4¾"	22"	¾"	13 watts	<b>LT2CHI</b>	\$323

## Mini LED Task Light



	Standard Includes	Required to Specify
<p>▶ Need help? See <i>Details</i> <i>Specification Guide</i> for product details.</p>	<ul style="list-style-type: none"> <li>• Light: 4799 Platinum</li> <li>• 9' power cord</li> <li>• Attachment hardware</li> </ul>	<ul style="list-style-type: none"> <li>Style number</li> </ul>

Specification Information				
• Dimensions			• Style	• U.S.
D	W	H	Number	Price
1½"	7"	¾"	<b>LMINILED</b>	\$236



**For Canadian Pricing**  
 Multiply U.S. Price by the Canadian price factor.  
 ▶ See page 1 for details.

# SOTO

## Tour Rails

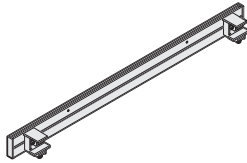

*Tip: Allow 1" clearance between worksurface and rail for cable management. Allow 2" for rail mount installed behind a worksurface, and 3¾" overall to install the rail.*

*Tip: Maximum weight load rails are 2 pounds per linked inch.*

*Tip: Each clamp requires a 2" footprint above the worksurface, and a 3¼" clearance below the worksurface.*

*Tip: Tour rails clamp to Tour bench troughs. Rails are not applicable for glass surfaces.*

Standard Includes	Required to Specify
-------------------	---------------------

- |   |  |
|---|--|
| <ul style="list-style-type: none"> <li>• Rail: 4799 Platinum</li> </ul> | <ul style="list-style-type: none"> <li>Style number</li> </ul> |
|---|--|

Related Products
------------------

- |  |   |
|--|---|
| <ul style="list-style-type: none"> <li>• SOTO shelves</li> <li>• SOTO Worktools</li> </ul> | <ul style="list-style-type: none"> <li>▶ Page 285</li> <li>▶ Pages 283–286</li> </ul> |
|--|---|

Specification Information					
---------------------------	--	--	--	--	--

Corresponding Table Top Width	Dimensions			Style Number	U.S. Price
	D	W	H		
60"	1"	52"	3¼"	<b>DSRT52</b>	\$245
66"	1"	58"	3¼"	<b>DSRT58</b>	\$257
72"	1"	64"	3¼"	<b>DSRT64</b>	\$270
:	:	:	:	:	:

Tour Workspace

**Products on this page are Details, not turnstone.** They are included here to simplify your planning. Remember that Details has different pricing terms than turnstone products.



**For Canadian Pricing**  
 Multiply U.S. Price by the Canadian price factor.  
 ▶ See page 1 for details.

# Surface Materials

► For Surface Materials matrices for all product lines, see page 305.

## Laminate

### Steelcase Surfaces

#### Low-Pressure Laminate

Applies to:

- Counter center infill and end panel infill
- Laminate worksurface supports
- Countertops
- Worksurfaces
- Shelves
- Modesty panels
- Screens
- HV cabinet doors
- Bookcases
- Pile file
- My file

- 25L1 Winter on Maple LPL
- 25L5 Virginia Walnut LPL
- 25L6 Blackwood LPL
- 25L8 Clear Walnut LPL
- 25L9 Warm Oak LPL **E**
- 26L1 Natural Cherry Version 2 LPL
- 2L30 Arctic White LPL

#### High-Pressure Laminate

Applies to: (standard products)

- Worksurfaces
- Shelves

#### Fiber Laminate

- 2851 Rhyme Fiber **E**
- 2854 Vellum Fiber
- 2859 Novell Fiber
- 2860 Granite Fiber
- 2861 Coconut Fiber
- 2862 Stucco Fiber

#### Micro Laminate

- 2920 Marl Micro
- 2921 Gypsum Micro
- 2922 Clay Micro
- 2923 Shadow Micro **E**

#### Patina Laminate

- 2870 Blonde Bronze Patina
- 2871 Blackened Bronze Patina
- 2873 Instant Iron Patina

#### Solid Laminate

- 2722 Cream **E**
- 2730 Arctic White
- 2759 Warm White **E**
- 2811 Mist **E**
- 2884 Milk

*Tip: Established finishes are available for delivery in 15 business days.*

**E** = Established

#### Speckle Laminate

- 2820 Coffee Speckle
- 2822 Woodrose Speckle **E**
- 2823 Driftwood Speckle
- 2824 Smoke Speckle
- 2825 Vanadium Speckle

#### Woodgrain Laminate

- 2406 Clear Cherry
- 2412 Natural Cherry
- 2422 Medium Cherry
- 2511 Winter on Maple
- 2538 Clear Walnut
- 2539 Warm Oak **E**
- 2592 Blonde on Maple
- 2714 Natural Walnut
- 2772 Medium Mahogany on Walnut **E**
- 2HAK Clear Oak

#### Turnstone Laminate Collection

- 2535 Virginia Walnut
- 2536 Blackwood

#### Custom Surfaces

##### Open Line Laminate (OLL)

This service allows you to order non-standard laminate at an additional processing fee of \$67 U.S. per worksurface or top, plus the cost of the laminate.

When processing orders for Open Line laminate on turnstone products, specify 2900 in the laminate finish field and enter the OLL manufacturer information. Enter the required edge finish as you would a standard laminate.

**Edge color** for the Open Line laminate on turnstone products must be determined by the dealer and customer before orders can be entered. Specify appropriate 2K finish number.  
*Tip: Standard laminates being used in the Open Line Laminate program to obtain a different edge detail will be charged the Open Line laminate upcharge; however, no additional charges for the laminate will be applied.*

#### Laminate Approval and Material Requirements

To confirm whether a particular laminate has already been tested for use on a specific Steelcase product or to determine material square foot requirements:  
• Visit [www.steelcase.com](http://www.steelcase.com)

**For additional information**, refer to the *Steelcase Surface Materials Reference Manual*.

## Plastic

### Steelcase Surfaces

Applies to:

- Worksurface edge band
- Shelf edge band

- 6000 Black\*
- 6001 Coffee
- 6009 Arctic White\*
- 6034 Natural Cherry
- 6036 Medium Cherry
- 6037 Winter on Maple
- 6038 Blonde on Maple
- 6041 Natural Walnut
- 6045 Medium Mahogany on Walnut **E**

- 6052 Milk
- 6053 Seagull\*
- 6234 Clear Cherry\*
- 6242 Virginia Walnut\*
- 6243 Blackwood\*
- 6245 Clear Walnut\*
- 6246 Warm Oak\* **E**
- 6249 Platinum Solid
- 6615 Grey Value 5
- 6619 Ice **E**
- 6631 Cream
- 6635 Dawn **E**
- 6636 Mist\*
- 6654 Sand\*
- 6655 Warm White\*
- 6676 Marbled White
- 6677 Chocolate Walnut
- 6678 Marbled Cherry
- 6689 Brushed Silver\* **E**
- 6694 Slate
- 6695 Midnight
- 6697 Fog
- 6698 Fieldstone

\*These solid color and wood grain edge colors are a polyolefin blend, PVC-free material for 3 mm and 1 mm edge bandings.

Applies to:

- Vertical cord cover grommet insert

- 6000 Black
- 6009 Arctic White
- 6249 Platinum Solid

## Paint

### Steelcase Surfaces

Applies to:

- Counter top tray
- Counter center infill
- HV and shared HV cabinets
- Vertical cord cover
- Pile file top, back, and fixed center shelf
- Bench trough
- Bench screen
- Post legs
- Worksurface frame support
- Modesty panel bracket

#### Price Group 1

- 7207 Black (Textured)
- 7225 Sand (Textured)
- 7241 Arctic White (Textured)
- 7243 Seagull (Textured)

#### Price Group 2

- 4750 Champagne Metallic
- 4798 Sterling Metallic
- 4799 Platinum Metallic
- 7246 Midnight Metallic (Textured)

Applies to:

- HV cabinet laminate sliding door pulls
- Pile file turnstone ledge pulls
- My file turnstone ledge pull

#### Price Group 1

- 7207 Black (Textured)

#### Price Group 2

- 4799 Platinum Metallic

## HV Cabinet Center Divider

### Steelcase Surfaces

HV cabinet center divider laminate color number defaults based on the paint selection.

#### Cabinet paint:

#### Default laminate center divider:

4750 Champagne Metallic	2L85 Dune
4798 Sterling Metallic	247L Black
4799 Platinum Metallic	247L Black
7207 Black (Textured)	247L Black
7225 Sand (Textured)	2L85 Dune
7241 Arctic White (Textured)	2L30 Arctic White
7243 Seagull (Textured)	2L83 Seagull
7246 Midnight Metallic (Textured)	247L Black

## Upholstery

### Steelcase Surfaces

Applies to:

- Magnetic tackboards

#### Systems Upholstery

##### Price Group 1

- Boccie

#### Seating Upholstery

##### Price Group 1

- Buzz2

##### Price Group 2

- Nitelights

#### turnstone Designtex Seating Upholstery

##### Price Group 4

- Boyne
- Great Lakes

---

# Campfire



## Statement of Line 130



### Product Details

Big Table Facts	132
LED Personal Task Lights	134
Mobile Storage Cabinet Facts	136
Big Lounge, Screen, and Big Lamp Facts	137
Half Lounge, Wedge, and Ottoman Facts	138
Personal Table and Paper Table Facts	139
Slim Table, Skate Table, and Footrest Facts	140



### Specifying

Big Tables	142
Big Tables with Trough	143
Table Accessories	144
Mobile Storage Cabinets	145
Big Lamp	146
Personal Table	147
LED Personal Task Lights	148
Paper Table and Accessories	149
Screens	151
Big Lounge	152
Half Lounge, Wedge, and Ottoman	153
Slim Table, Skate Table, and Footrest	156
Accessories	158



## Surface Materials 159

# Statement of Line

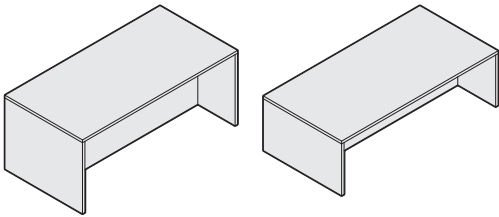

**Big Tables**  
▶ Page 142

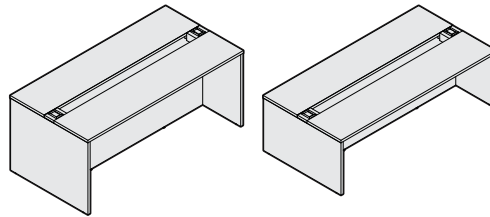

**Big Tables with Trough**  
▶ Page 143

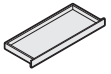

**Table Drawer**  
▶ Page 144



**Center Rail**  
▶ Page 144



**Mobile Storage Cabinets**  
▶ Page 145

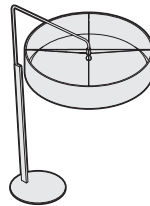

**Big Lamp**  
▶ Page 146



**Personal Table**  
▶ Page 147



**Paper Table**  
▶ Page 149

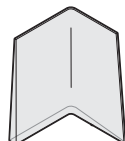

**Screens**  
▶ Page 151

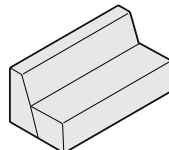

**Big Lounge**  
▶ Page 152

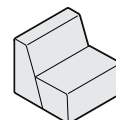

**Half Lounge**  
▶ Page 153

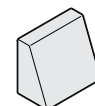

**Wedge**  
▶ Page 154



**Ottoman**  
▶ Page 155

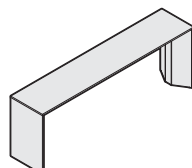

**Slim Table**  
▶ Page 156



**Skate Table**  
▶ Page 157



**Footrest**  
▶ Page 157

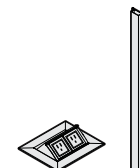

**Accessories**  
▶ Page 158

**Personal task lights** offer end users added control and adjustability to place the proper amount of personal lighting to create a holistic worksetting. Ideally suited for rail-mount, desk, or freestanding applications.

## LED Lights

Rail-Mounted and Non Rail-Mounted

### LED Personal Task Lights

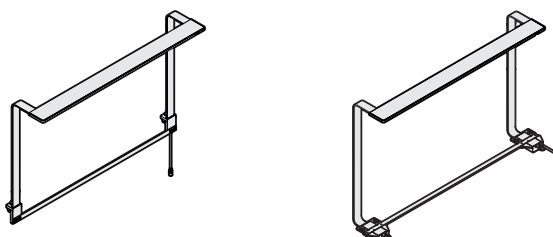

#### Mounting

- Rail-mounted attaches directly to rail systems in c:scape, FrameOne, Elective Elements, Impact, turnstone Campfire Big Table, and Details SOTO Rail. The non rail-mounted version attaches to most freestanding desks and tables.

*Tip: Non rail-mounted LED personal task lights will not work on worksurfaces with knife edge that is longer than 1¼", or with modesty panels or modesty screens closer than 6" from the back edge.*

Understanding

- ▶ Page 134  
Specifying
- ▶ Page 148

#### Depth

6"

#### Width

30"

#### Lamp

120 LEDs

#### Color Temperature

3500K

#### Description

Intended to be a primary light source, LED personal task light covers the user's active work zone with a smartly-designed array of light. The light is specifically designed to direct light where it is needed. Energy efficient at only 14 watts, LED personal task light is engineered to have a useful life of over 50,000 hours. It attaches directly to the rail systems of c:scape, FrameOne, Impact, Elective Elements, turnstone Big Table, and Details SOTO Rail. A non-rail-mounted version attaches to freestanding desks and tables.

#### Finish Options

- Fixture and stanchions, paint: 4799 Platinum Metallic, 4231 Arctic White, 4710 Low Gloss Black. Plastic cover Arctic White (6009) only.

#### Optics

- Polycarbonate matte film

#### Ballasts

- Energy saving low-voltage power supply

#### Electronic Dimmer

- Standard on all lights

#### Average Rated Lamp Life

- 50,000 hrs.

#### Warranty

- Power supply - 5 years
- Fixture - 12 years

# Big Table Facts

**Big Tables** are offered in Low-Pressure Laminate. Table tops and end panels are 1 $\frac{9}{8}$ " thick and center panel is 1" thick. Table top comes standard with two reinforcing channels built into the worksurface for added strength.  
 ▶ Specifying, page 142

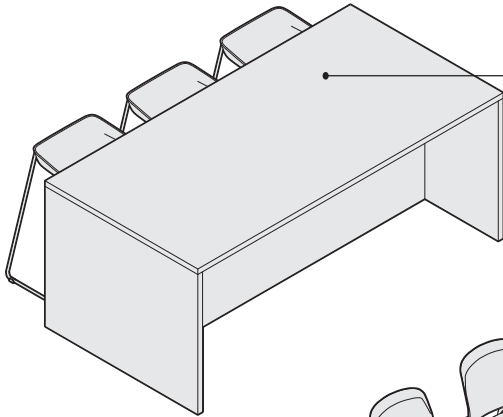

**Big Tables** are available at seating height of 28" high or standing height of 40" high.

**Big Tables** are available with an uninterrupted worksurface or Big Tables can be specified with a split worksurface top with a trough that runs down the center of the table.

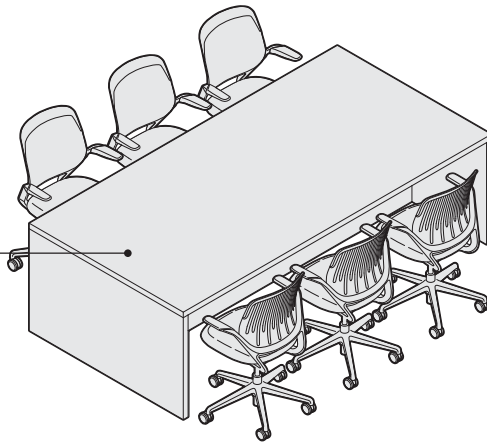

**Big Table trough** has a 10" depth, with a 6" open inside the split worksurface and 2" open each side underneath the Big Table worksurface.

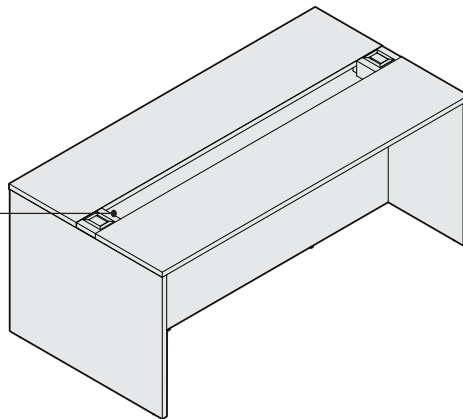

## Product Details

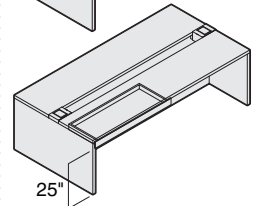
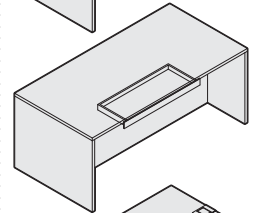
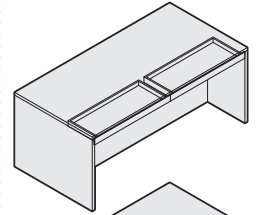

**Low-Pressure Laminate table drawer** is 3"D x 48"W, can be placed in three locations on either side of the Big Table and Big Table with Trough. Trough must be ordered separately.  
*Tip: When used on a 28"H Big Table knee clearance will be reduced by 3".*

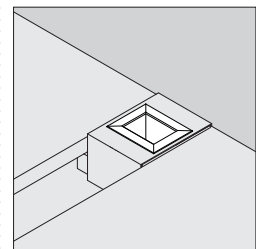

**Flip grommets** come standard on each end of Big Table with trough when power is not optioned.

## Actual Dimensions

Depth	48"
Width	96"
Height	28" or 40"

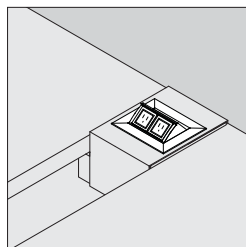

**Two receptacles for power (TS4TPWR)** are available in place of the standard grommet on each end.

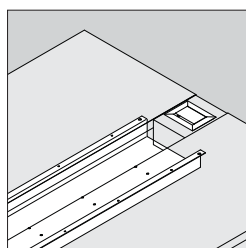

**Big Table trough** is a painted platinum open steel technology tray that allows for cable management. Either end of the trough comes standard with an anodized aluminum grommet that has a flip-top panel for access to route cables. Trough comes standard on split worksurface.

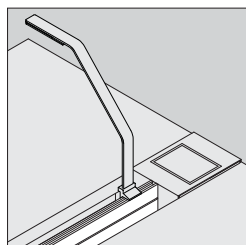

**Optional anodized aluminum table rail** installs in the table trough and allows for Details SOTO rail accessories. Can be ordered separately.

## Wiring and Cabling

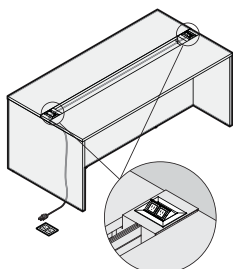

**Dual anodized aluminum power and data solutions** are available as a standard option or field installed. 15-amp, one-circuit power solution with a 10' cord is standard. TS4TPWR and TS4TPWRD requires one building outlet and provides four user outlets. When ordering data TS4TPWRD, user will get one outlet and one data opening on each end.

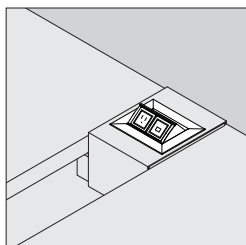

**One receptacle and one data (TS4TPWRD)** are available in place of the standard grommet on each end.

*Tip: Includes open data port. Communication voice/data jacks are customer provided.*

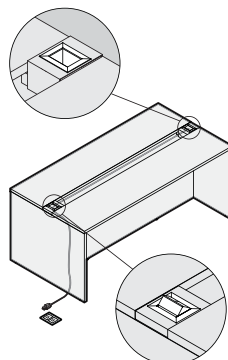

**Single anodized aluminum power and data solutions** are also available for field installation. They replace one of the standard grommets. 15-amp, one-circuit power solution with a 10' cord is standard. TS4TPWR1 and TS4TPWRD1 provide a lower cost solution that requires one building outlet and provides two user outlets. When ordering data TS4TPWRD1, user will get one outlet and one data opening.

**Two receptacle (TS4TPWR1)** replaces one of the standard grommets.

**One receptacle/one data (TS4TPWRD1)** replaces one of the standard grommets.

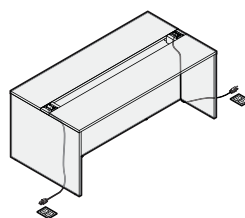

**When using two single anodized power and data solutions**, a second building outlet is required.

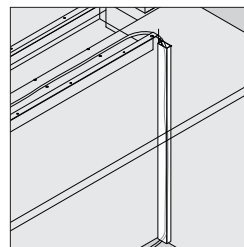

**Vertical cord covers (TS4TVWM28 and TS4TVWM40)** come in two heights, 28"H and 40"H. Vertical cord covers are used to route electrical cords vertically on Big Table with Trough.

## Surface Materials

### Big Table and Table Drawer

- Low-Pressure Laminate

### Trough

- 4799 Platinum Metallic

### Electrical/communication components

- Anodized aluminum

### Vertical wire management

- Black plastic

# LED Personal Task Lights

► Specifying, page 148

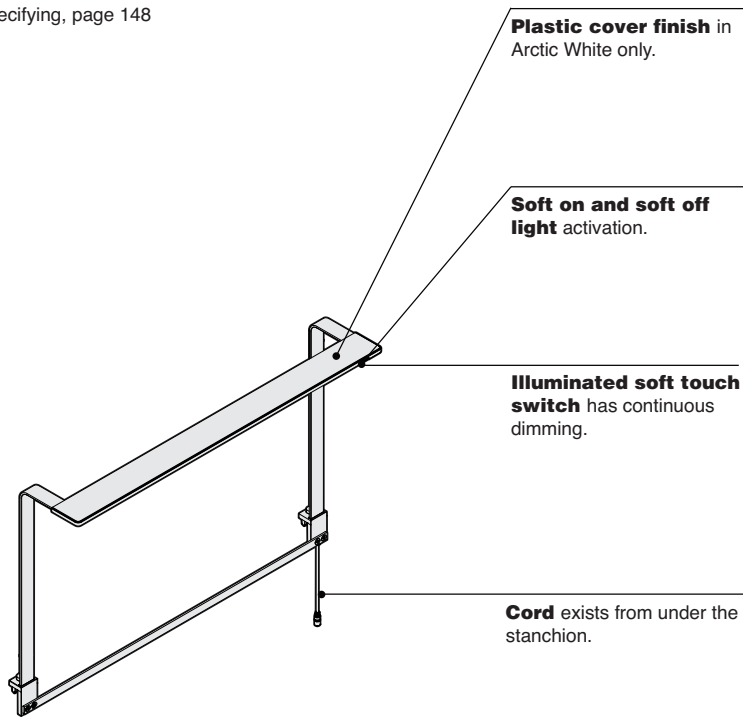

**Plastic cover finish** in Arctic White only.

**Soft on and soft off light activation.**

**Illuminated soft touch switch** has continuous dimming.

**Cord** exists from under the stanchion.

## Product Details

**Personal task light** includes the lamp and power supply with cord set. Rail-mounted version includes rail brackets. Non rail-mounted version includes Universal Mounting brackets.

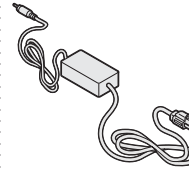

**Power supply** uses a modular cord with standard two prong plug, an integrated low voltage cord, and a connector to attach to light.

*Tip: Energy saving mini-LEDs greatly reduce power use.*

## Connections

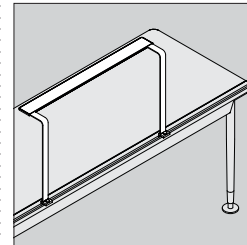

**LED personal task light** mounts directly to the rail systems of c:scape, Frame-One, Elective Elements, Impact, turnstone Campfire Big Table, and Details SOTO rail.

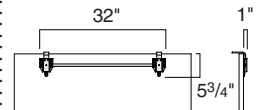
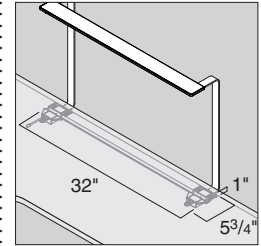

**Non rail-mounted LED personal task lights** will not work on worksurfaces with knife edge that is longer than 1 1/4", or with modesty panels or modesty screens closer than 6" from the back edge.

## Wiring & Cabling

**Personal task light** includes the lamp and power supply with cord set.

**Power supply** uses a modular cord with standard two prong plug, an integrated low voltage cord, and a connector to attach to light.

## Surface Materials

### Housing

- 6009 Arctic White plastic only

### Fixture and Stanchions

- 4231 Arctic White
- 4710 Low Gloss Black
- 4799 Platinum Metallic

### Cord

- Black plastic only

## Actual Dimensions

**Depth** 6"

**Width** 30"

**Height** 17"

Power Supply Cord Set (12')

-Line voltage cord: 6'

-Low voltage cord: 6'

**Photometric Data**

**LED Personal Task Lights**

Initial horizontal footcandles for LPTL30 and LPTL30NR  
 Worksurface rear

0"	15	14	13	12	11	9	6	6	5	4	3	2	2
3"	21	20	18	17	15	13	11	8	6	5	3	3	2
6"	31	31	29	26	23	19	15	12	9	7	5	3	2
9"	51	50	46	42	36	29	23	18	13	9	6	4	3
12"	82	79	73	64	53	43	32	23	16	11	7	5	3
15"	109	105	96	83	68	53	39	27	19	12	8	6	4
18"	105	102	93	81	66	51	37	27	18	12	9	6	4
21"	76	75	69	59	50	39	30	22	16	11	7	5	4
24"	48	47	44	39	33	27	21	16	12	9	6	5	3
27"	29	28	27	24	21	17	14	11	9	7	5	4	3
30"	18	18	17	16	14	12	10	8	7	5	4	3	2
CL	3"	6"	9"	12"	15"	18"	21"	24"	27"	30"	33"	36"	
	Worksurface front												

# Mobile Storage Cabinet Facts

**Mobile storage cabinets and storage cabinet wardrobes** are offered as left-hand or right-hand units in Low-Pressure Laminate with two adjustable shelves.  
 ▶ Specifying, page 145

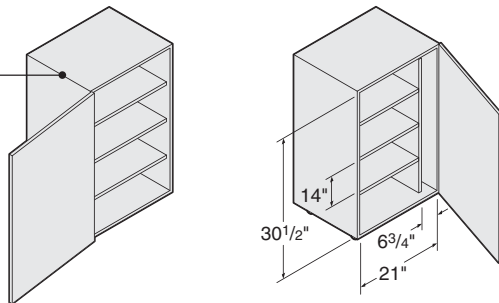

**Storage cabinets** can be used with 40"H Big Tables and Big Tables with Trough or as freestanding storage units.

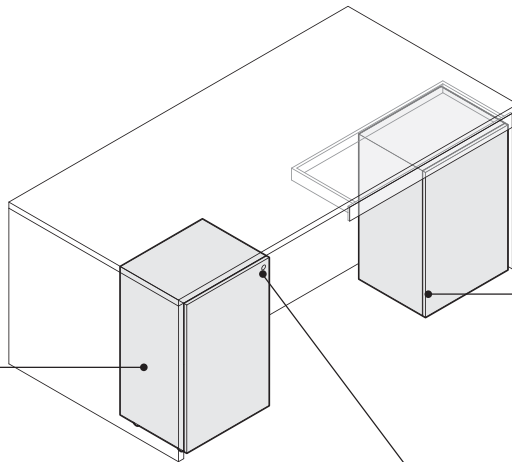

**Mobile storage cabinets** ship standard with casters. When mobile storage cabinets are intended to be used underneath a table drawer, the glide option will need to be selected to provide enough clearance underneath the drawer.

**Storage cabinets and wardrobe** have an optional front-removable lock.

## Product Details

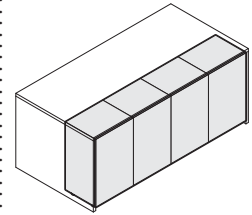

**Up to four mobile storage cabinets** can fit up to four per side underneath a Big Table.

## Surface Materials

**Mobile Storage Cabinets and Storage Cabinet Wardrobe**

- Low-Pressure Laminate

## Actual Dimensions

Depth	18 1/2"
Width	23"
Height (with casters)	38"
Height (with glides)	35"

# Big Lounge, Screen, and Big Lamp Facts

Big Lounge, Screen, and Big Lamp Facts

**Big Lounge** comes standard armless with black plastic feet. Available options include single or multiple fabrics on back and seat.   
▶ Specifying, page 152

**Big Lamp** has a painted steel base with fabric lamp shade and white diffuser. At a height of 7'-9", the Big Lamp can be installed in a room with an 8' high ceiling or taller. 15-amp plug with 9' electrical cord and an on/off foot switch.   
▶ Specifying, page 146   
*Tip: Consult local fire code authorities if a Big Lamp is placed near ceiling sprinkler system.*

**Screens** are constructed with a steel frame and a mesh sock. Screens are handed. Right-hand and left-hand versions are available.   
▶ Specifying, page 151

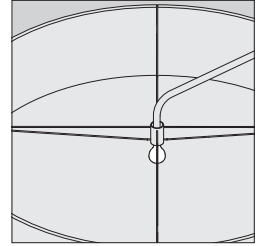
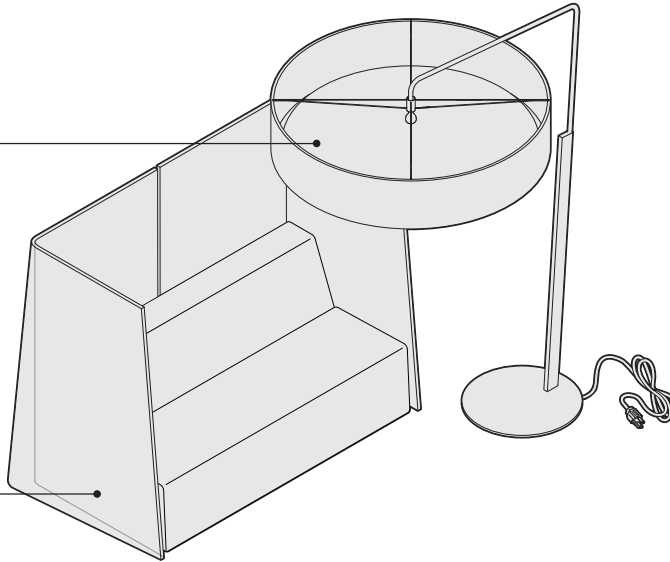

**Light bulb** is not included. Use a 100 watt A19 incandescent bulb. A compact fluorescent bulb can be used as long as the overall length does not exceed 47<sup>1</sup>/<sub>16</sub>".

## Surface Materials

- Big Lounge**
- Fabric Price Groups 1-10
  - COM
- Big Lamp**
- Painted steel base
  - Fabric screen and white diffuser
- Screen**
- Mesh: T615 Sultry Smoke

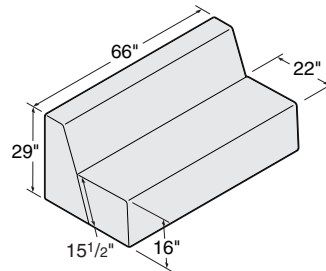
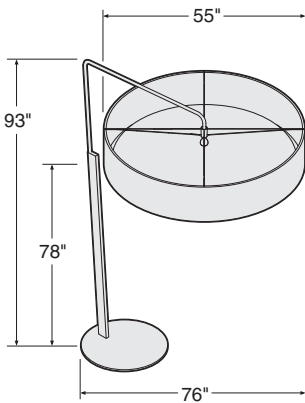

## Product Details

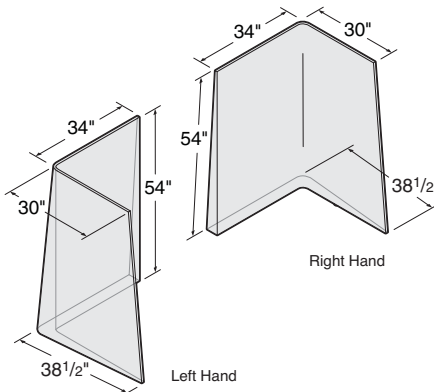

**Screens** are available in left- and right-hand versions.

## Actual Dimensions

### Big Lounge

Depth	32"
Width	66"
Height	29"

### Big Lamp

Depth	76"
Width	55"
Height	93"

### Shade

Diameter	55"
----------	-----

# Half Lounge, Wedge, and Ottoman Facts

**Half Lounge** comes standard armless with black plastic feet. Available options include single or multiple fabrics on back and seat.  
 ▶ Specifying, page 153

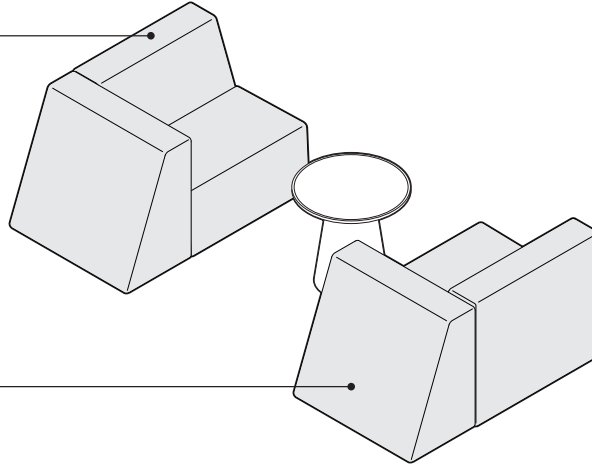

**Wedge** comes standard with black plastic feet and stability brackets. Independent Wedges and Half Lounges may be positioned into any configuration without moving or removing the stability brackets.  
 ▶ Specifying, page 154

**Ottoman** supports up to 225 pounds.

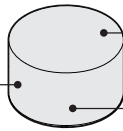

**Ottoman** ships fully assembled.

**Ottoman** is the same as a light round ottoman. It is often shown with Campfire and referred to as Campfire ottoman. It is being included in the Campfire lounge specifying section for easy reference.  
 ▶ Specifying, page 155

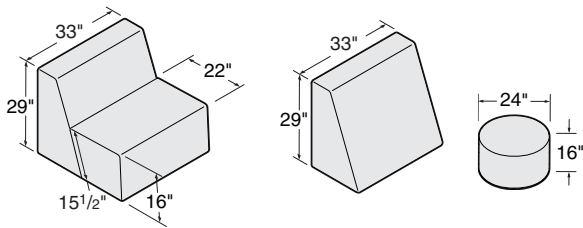

## Actual Dimensions

	Half Lounge	Wedge	Ottoman
Depth	32"	17 7/8"	
Width	33"	33"	24"
Height	29"	29"	16"

*Tip: Specify ottoman with low profile glides to achieve 16"H.*

## Product Details

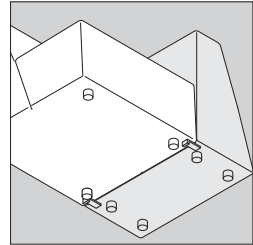

**Wedges** connected to the side of a Half Lounge would use the stability brackets facing towards the back as they come standard.

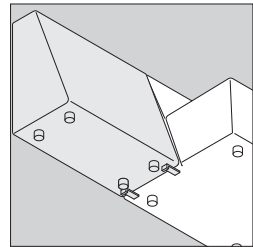

**Wedges** connected to the back of a Half Lounge or in-line with another Wedge would require moving the stability brackets to the side.

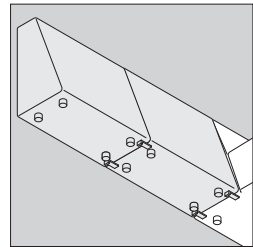

**No more than two Wedges** can be attached to a single lounge. Wedges can be freestanding, either alone or next to the Big Lounges or Half Lounges.

## Surface Materials

### Half Lounge and Wedge

- Fabric Price Group 1-10
- COM

# Personal Table and Paper Table Facts

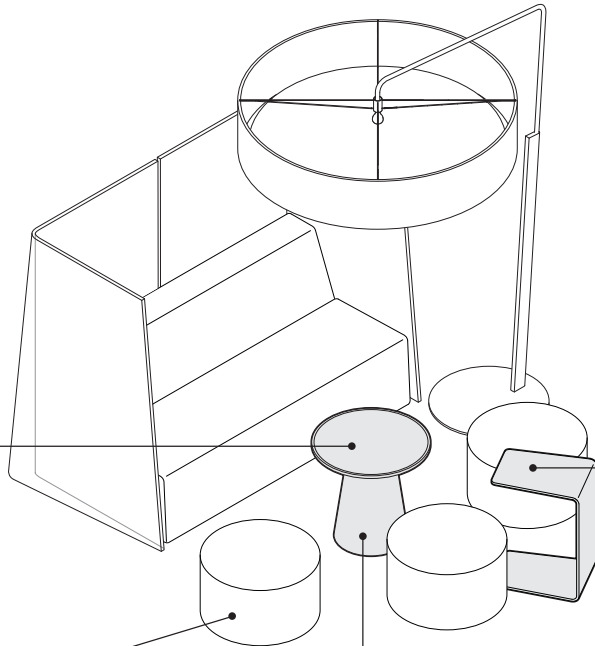

**Paper table** has three top configurations:

- Paper (installed over steel table top tray)
- Glass (installed over steel table top tray)
- Steel table top tray

► Specifying, page 149

**Light round ottoman** shown in this Campfire setting includes the low-profile glide option. This option decreases the seat height from 19" down to 16".

► Specifying, page 155

**Personal table** is constructed of bent plywood with rift-cut natural oak veneer finish. It nests underneath Big Lounge and can be used for a writing surface or laptop.

► Specifying, page 147

*Tip: The angle design is not approved to be used for food or drinks. The personal table is not intended to be sat or stood on.*

**Paper table** is constructed with laminate base, plastic rotating table top, and steel table top tray.

## Product Details

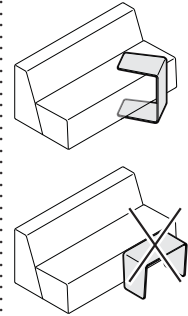

**Personal table** is designed to be used in the vertical position only.

## Surface Materials

**Paper Table Base**

- Low-Pressure Laminate

**Paper Table Rotating Table Top**

- Plastic: Arctic White

**Paper Table Top Tray**

- Steel: Arctic White paint

**Personal Table**

- 3611 Natural Oak Veneer

## Actual Dimensions

Paper Table	
Depth	18"
Width	18"
Height	23½"

Personal Table	
Depth	19½"
Width	14"
Height	26"

# Slim Table, Skate Table, and Footrest Facts

**Slim table** serves as a functional anchor at a lounge setting, providing space definition, surface for piling, and distributing power for technology.  
 ▶ Specifying, page 156

**Footrest** supports feet and legs and is designed to be used in multiple orientations to encourage active movement when in a lounge posture.  
 ▶ Specifying, page 157

**Footrest** is grey expanded polypropylene with a plastic band available in five finishes.

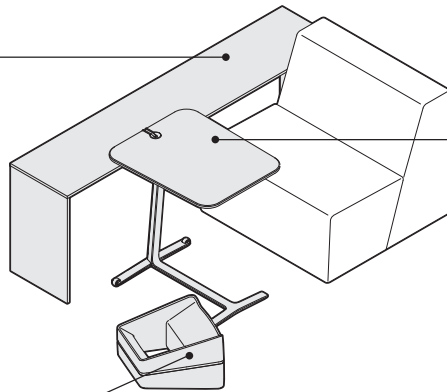

**Skate table** is constructed of a painted steel base with 1/2" top in Low-Pressure Laminate (LPL), High-Pressure Laminate (HPL), or 3611 Natural Oak veneer.  
 ▶ Specifying, page 157  
*Tip: The skate table is not intended to be sat on or stood on.*

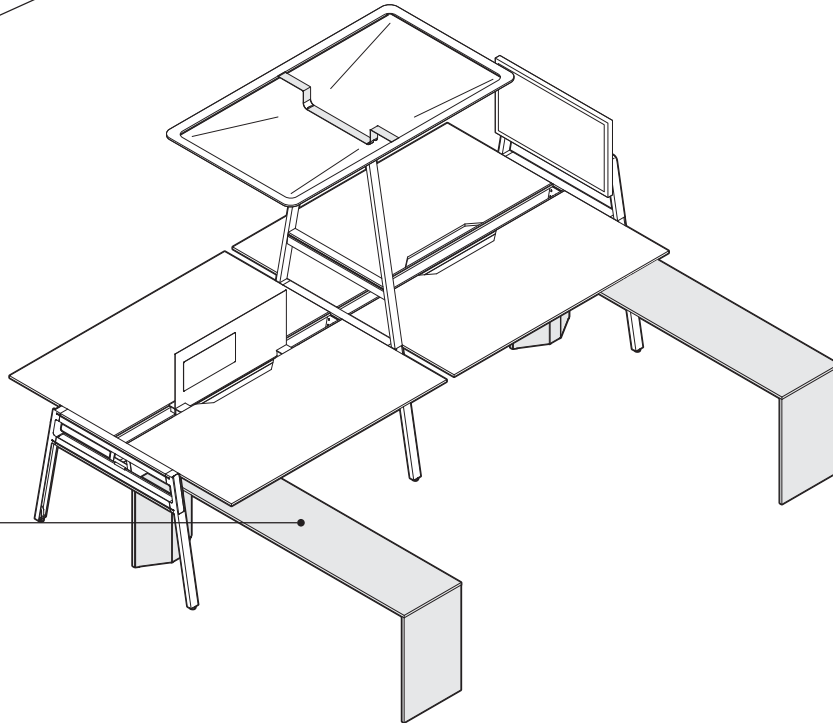

**Slim table** is constructed of a painted steel frame with 1/2" top and side panels in Low-Pressure Laminate (LPL), High-Pressure Laminate (HPL), or 3611 Natural Oak veneer.

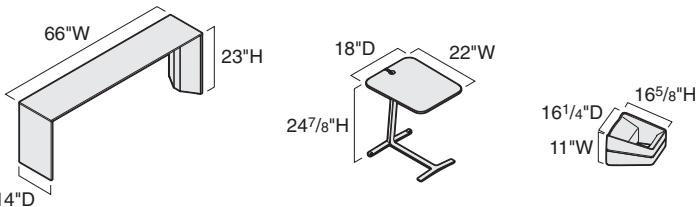

## Actual Dimensions

	Slim Table	Skate Table	Footrest
Depth	14"	18"	16 <sup>5</sup> / <sub>8</sub> "
Width	66"	22"	16 <sup>1</sup> / <sub>4</sub> "
Height	23"	24 <sup>7</sup> / <sub>8</sub> "	11"
Weight	43 <sup>1</sup> / <sub>2</sub> lbs.	10 <sup>1</sup> / <sub>2</sub> lbs.	2 <sup>1</sup> / <sub>4</sub> lbs.

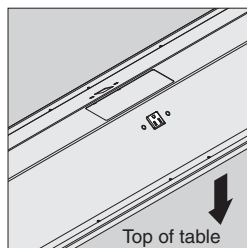
**Product Details****Slim Table**

**Slim table** comes equipped standard with two platinum simplex 15-amp power receptacles in the middle of each side of the table.

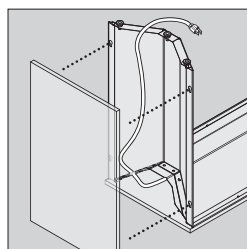

**The power cord** has 78" (6½ feet) of length from the bottom of the slim table to reach a power outlet.

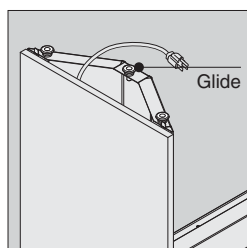

**Glides** are self leveling, three on either side of the table and are not adjustable.

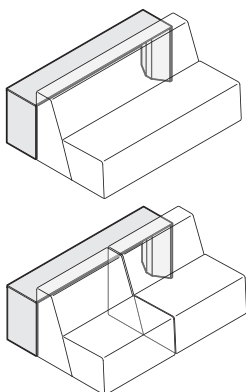

**The slim table's 66" width** fits perfectly behind a Big Lounge or two Half Lounges.

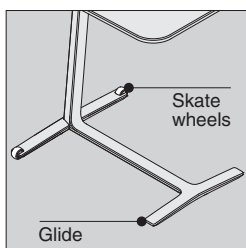
**Skate Table**

**Skate table** comes equipped with two hard plastic glides on the front of the table base, but also two skate wheels on the back of the table base for easy maneuvering.

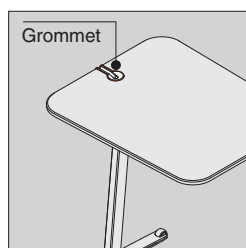

**Skate table** has a Merle plastic grommet to manage cords when powering technology.

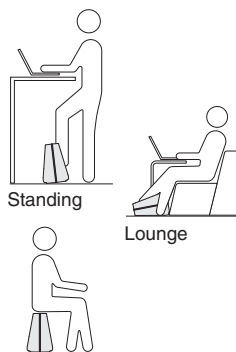
**Footrest**

**Footrest** can be used when in a lounge posture, seated, or standing height. It can also be used as a guest chair.

**Surface Materials****Slim Table and Skate Table**

- Low-Pressure Laminate
- High-Pressure Laminate
- Veneer: 3611 Natural Oak

**Slim Table and Skate Table**

- 4140 Arctic White Gloss
- 4799 Platinum Metallic
- 7246 Midnight Metallic

**Skate Table grommet**

- 6527 Merle

**Footrest band**

- 6009 Arctic White
- 6333 Picasso
- 6335 Wasabi
- 6338 Chili
- 6527 Merle

**High-Pressure Laminate edge**

- Plastic

**Weight Capacities**

**Slim Table:** 240 pounds

**Skate Table:** 40 pounds

# Big Tables

Standard Includes	Required to Specify
-------------------	---------------------

- |  |  |  |
|--|--|--|
| <ul style="list-style-type: none"> <li>▶ Need help? Product details, page 132</li> </ul> | <ul style="list-style-type: none"> <li>• 1 3/8"-thick worksurface center and end panel: Low-Pressure Laminate</li> <li>• 3 mm radius edge band 4 top sides: default color to match laminate</li> <li>• 1 mm radius edge band vertical: default color to match laminate</li> <li>• Adjustable leveling glides</li> <li>• Shipped ready to assemble</li> </ul> | <ul style="list-style-type: none"> <li>1 Style number</li> <li>2 Low-Pressure Laminate color number for table top, center, and end panel</li> <li>▶ See <i>Surface Materials</i>, page 159.</li> </ul> |
|--|--|--|

Related Products
------------------

- |   |  |
|---|--|
| <ul style="list-style-type: none"> <li>• Mobile storage cabinets and wardrobes</li> <li>• Table drawer</li> </ul> | <ul style="list-style-type: none"> <li>▶ Page 145</li> <li>▶ Page 144</li> </ul> |
|---|--|

Specification Information				
Dimensions			Style	U.S.
D	W	H	Number	Price

48"	96"	28"	<b>TS4TL28</b>	\$1767
-----	-----	-----	----------------	--------

48"	96"	40"	<b>TS4TL40</b>	\$1976
-----	-----	-----	----------------	--------

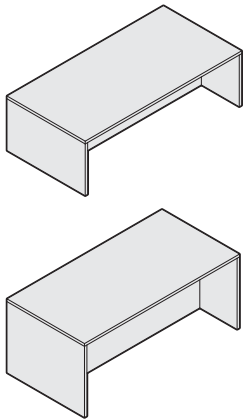

**For Canadian Pricing**  
 Multiply U.S. Price by the Canadian price factor.  
 ▶ See page 1 for details.

# Big Tables with Trough

Standard Includes		Required to Specify
<ul style="list-style-type: none"> <li>▶ Need help? Product details, page 132</li> </ul>	<ul style="list-style-type: none"> <li>• 1 3/8"-thick worksurface center and end panel: Low-Pressure Laminate</li> <li>• 3 mm radius edge band 4 top sides: default color to match laminate</li> <li>• 1 mm radius edge band vertical: default color to match laminate</li> <li>• Technology trough: 4799 Metallic Platinum</li> <li>• Grommet on each end of trough: anodized aluminum</li> <li>• Adjustable leveling glides</li> <li>• Shipped ready to assemble</li> </ul>	<ul style="list-style-type: none"> <li>1 Style number</li> <li>2 Low-Pressure Laminate color number for table top, center, and end panel</li> <li>3 Options, if selected (see below)</li> <li>▶ See <i>Surface Materials</i>, page 159.</li> </ul>

*Tip: Pop-up receptacles come with a 10' cord.*

*Tip: For use in Chicago, use TS4TPWR1 or TS4TPWRD1 pop-up power receptacle and data only.*

Options	U.S. Price	Required to Specify
<b>Receptacles</b> <ul style="list-style-type: none"> <li>• Pop-up receptacle: set of 2 power on each end</li> <li>• Pop-up receptacle: set of 1 power, 1 data on each end</li> </ul>	<ul style="list-style-type: none"> <li>+\$733</li> <li>+\$733</li> </ul>	<ul style="list-style-type: none"> <li>Specify with 2 power receptacle and specify paint color number.</li> <li>Specify with 1 power/1 data receptacle and specify paint color number.</li> </ul>
<b>Center Rail</b> <ul style="list-style-type: none"> <li>• Anodized aluminum</li> </ul>	<ul style="list-style-type: none"> <li>+\$279</li> </ul>	<ul style="list-style-type: none"> <li>Specify with center rail.</li> </ul>
<b>Related Products</b> <ul style="list-style-type: none"> <li>• Mobile storage cabinets and wardrobes</li> <li>• Table drawer</li> <li>• Data management and power</li> </ul>		<ul style="list-style-type: none"> <li>▶ Page 145</li> <li>▶ Page 144</li> <li>▶ Page 158</li> </ul>

## Specification Information

Dimensions			Style	U.S.
D	W	H	Number	Base Price
48"	96"	28"	<b>TS4TLT28</b>	\$2081

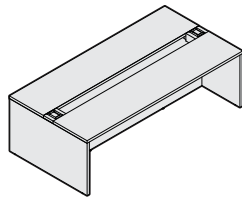

48"	96"	40"	<b>TS4TLT40</b>	\$2290
-----	-----	-----	-----------------	--------

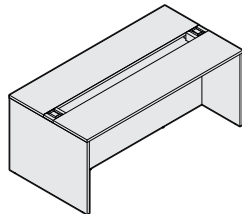

 **For Canadian Pricing**  
 Multiply U.S. Price by the Canadian price factor.  
 ▶ See page 1 for details.

# Table Accessories

## Table Drawer

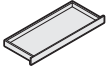

*Tip: If mobile storage cabinets or wardrobe is used underneath a table drawer, storage cabinets or wardrobe will require the glide option instead of casters in order to clear the table drawers.*

Standard Includes	Required to Specify
<ul style="list-style-type: none"> <li>▶ Need help? Product details, page 132</li> <li>• Drawer: Low-Pressure Laminate</li> <li>• Black laminate drawer interior</li> <li>• Attachment hardware</li> </ul>	<ul style="list-style-type: none"> <li>1 Style number</li> <li>2 Low-Pressure Laminate color number for drawer</li> <li>▶ See <i>Surface Materials</i>, page 159.</li> </ul>

Related Products	
<ul style="list-style-type: none"> <li>• Big Table</li> <li>• Big Table with trough</li> </ul>	<ul style="list-style-type: none"> <li>▶ Page 142</li> <li>▶ Page 143</li> </ul>

Specification Information				
• Dimensions			• Style	• U.S.
D	W	H	Number	Price
18"	46"	3"	<b>TS4TLDRW</b>	\$408

## Center Rail



Standard Includes	Required to Specify
<ul style="list-style-type: none"> <li>▶ Need help? Product details, page 133</li> <li>• Rail: anodized aluminum</li> <li>• Attachment hardware</li> </ul>	<ul style="list-style-type: none"> <li>Style number</li> </ul>

Related Products	
<ul style="list-style-type: none"> <li>• Big Table with trough</li> <li>• SOTO Worktools</li> </ul>	<ul style="list-style-type: none"> <li>▶ Page 143</li> <li>▶ Pages 283–290</li> </ul>

Specification Information				
• Dimensions			• Style	• U.S.
D	W	H	Number	Price
3 1/4"	80"	4 1/2"	<b>TS4TRAIL</b>	\$279



**For Canadian Pricing**  
 Multiply U.S. Price by the Canadian price factor.  
 ▶ See page 1 for details.

Tip: Remember to specify lock cylinder and key.  
 ▶ Lock cylinders, page 329

	Standard Includes	Required to Specify
▶ Need help? Product details, page 136	<ul style="list-style-type: none"> <li>Mobile storage cabinet: Low-Pressure Laminate</li> <li>Two, height-adjustable shelves</li> <li>Wardrobe on one side, if selected</li> <li>Casters</li> <li>Shipped assembled</li> </ul>	1 Style number 2 Low-Pressure Laminate color number for storage cabinet 3 Options, if selected (see below) ▶ See <i>Surface Materials</i> , page 159.

	Options	U.S. Price	Required to Specify
<b>Lock</b>	<ul style="list-style-type: none"> <li>9201 Polished Chrome</li> <li>9250 Ember Chrome</li> </ul>	+\$112 +\$112	Specify with <i>9201 Polished Chrome</i> . Specify with <i>9250 Ember Chrome</i> .
<b>Glides</b>	<ul style="list-style-type: none"> <li>Glides</li> </ul>	No cost	Specify with <i>glides</i> .
<b>Related Products</b>	<ul style="list-style-type: none"> <li>Big Tables</li> <li>Big Tables with trough</li> </ul>		▶ Page 142 ▶ Page 143

Specification Information				
Dimensions			Style	U.S.
D	W	H	Number	Base Price
:	:	:	:	:

## Storage Cabinets

### Left-hand

18½"	23"	38"	<b>TS4TSLH</b>	\$1002
:	:	:	:	:

### Right-hand

18½"	23"	38"	<b>TS4TSRH</b>	\$1002
:	:	:	:	:

## Storage Cabinet Wardrobes

### Left-hand

18½"	23"	38"	<b>TS4TSLH</b>	\$1002
:	:	:	:	:

### Right-hand

18½"	23"	38"	<b>TS4TSRH</b>	\$1002
:	:	:	:	:

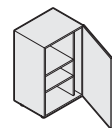
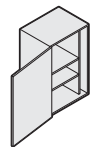
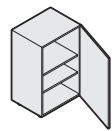
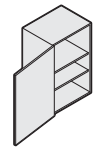

 **For Canadian Pricing**  
 Multiply U.S. Price by the Canadian price factor.  
 ▶ See page 1 for details.

# Big Lamp

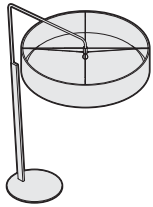

Tip: Shade diameter is 55".

Tip: Bottom of shade is 78" off of the floor.

Standard Includes	Required to Specify
-------------------	---------------------

- |  |  |   |
|--|--|---|
| <ul style="list-style-type: none"> <li>▶ Need help? Product details, page 137</li> </ul> | <ul style="list-style-type: none"> <li>• Lamp base: paint</li> <li>• Lamp shade: upholstery</li> <li>• 9' cord with three-prong plug</li> <li>• Shipped ready to assemble</li> </ul> | <ul style="list-style-type: none"> <li>1 Style number</li> <li>2 Paint color number for lamp base</li> <li>3 Upholstery color number for lamp shade</li> <li>▶ See <i>Surface Materials</i>, page 159.</li> </ul> |
|--|--|---|

Related Products
------------------

- |   |  |
|---|--|
| <ul style="list-style-type: none"> <li>• Ottoman</li> </ul> | <ul style="list-style-type: none"> <li>▶ Page 245</li> </ul> |
|---|--|

Specification Information				
• Dimensions			• Style	• U.S.
D	W	H	Number	Price

55"	76"	93"	<b>TS4TBL</b>	\$1719
-----	-----	-----	---------------	--------



**For Canadian Pricing**

Multiply U.S. Price by the Canadian price factor.

▶ See page 1 for details.



Standard Includes	Required to Specify
<ul style="list-style-type: none"> <li>▶ Need help? Product details, page 139</li> <li>• Personal table: 3611 Natural Oak Veneer</li> </ul>	<ul style="list-style-type: none"> <li>Style number</li> </ul>

Specification Information				
• Dimensions			• Style	• U.S.
D	W	H	Number	Price
19 1/2"	14"	26"	<b>TS4TWP</b>	\$492



 **For Canadian Pricing**  
 Multiply U.S. Price by the Canadian price factor.  
 ▶ See page 1 for details.

# LED Personal Task Lights

Standard Includes		Required to Specify
<ul style="list-style-type: none"> <li>▶ Need help? Product details, page 134</li> </ul>	<ul style="list-style-type: none"> <li>• Housing: 6009 Arctic White plastic only</li> <li>• Fixture and stanchions: paint</li> <li>• Power supply with 12' cordage (6' from power supply to power outlet, 6' from power supply to fixture)</li> <li>• Soft touch switch</li> <li>• Ultra energy efficient LED light source</li> <li>• Polycarbonate matte film diffuser</li> <li>• Continuous dimming</li> </ul>	<ul style="list-style-type: none"> <li>1 Style number</li> <li>2 Paint color number for fixture and stanchions:                             <ul style="list-style-type: none"> <li>4231 Arctic White</li> <li>4710 Low Gloss Black</li> <li>4799 Platinum Metallic</li> </ul> </li> </ul>

Related Products	
<ul style="list-style-type: none"> <li>• c:scape desk</li> <li>• FrameOne bench</li> <li>• Details SOTO rail</li> <li>• Impact</li> <li>• Technology zone integral rail</li> <li>• Worksurfaces and freestanding desks</li> <li>• Campfire Big Table</li> </ul>	<ul style="list-style-type: none"> <li>▶ See <i>c:scape Specification Guide</i>.</li> <li>▶ See <i>FrameOne Specification Guide</i>.</li> <li>▶ See <i>Details Specification Guide</i>.</li> <li>▶ See <i>Wood Casegoods and Tables Specification Guide</i>.</li> <li>▶ See <i>Elective Elements Specification Guide</i>.</li> <li>▶ See <i>Answer Specification Guide</i>.</li> <li>▶ Page 142.</li> </ul>

## Specification Information

Dimensions			Lamp	Style	U.S.
D	W	H	Wattage	Number	Price

### Rail-Mounted LED Personal Task Light

6"	30"	17"	14 watts	<b>LPTL30</b>	\$590
----	-----	-----	----------	---------------	-------

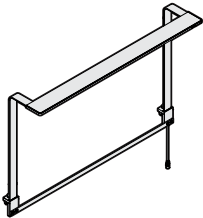

### Non Rail-Mounted LED Personal Task Light

6"	30"	17"	14 watts	<b>LPTL30NR</b>	\$590
----	-----	-----	----------	-----------------	-------

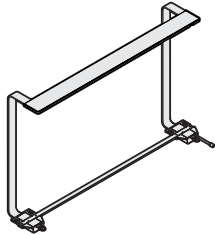

*Tip: Non rail-mounted LED personal task lights will not work on worksurfaces with knife edge that is longer than 1 1/4", or with modesty panels or modesty screens closer than 6" from the back edge.*



**For Canadian Pricing**  
 Multiply U.S. Price by the Canadian price factor.  
 ▶ See page 1 for details.

# Paper Table and Accessories

## Paper Table



*Tip: If glass option is selected, standard stack of paper will be omitted.*

	Standard Includes	Required to Specify
▶ Need help? Product details, page 139	<ul style="list-style-type: none"> <li>Table base: High-Pressure Laminate</li> <li>Plastic rotating table top: arctic white</li> <li>Steel table top tray: arctic white</li> <li>Stack of paper: 44 sheets</li> <li>Shipped assembled</li> </ul>	1 Style number 2 High-Pressure Laminate color number for table base 3 Options, if selected (see below) ▶ See <i>Surface Materials</i> , page 159.

	Options	U.S. Price	Required to Specify
<b>Paper</b>	<ul style="list-style-type: none"> <li>Omit paper</li> </ul>	-\$129	Specify with <i>omit paper</i> .
<b>Glass</b>	<ul style="list-style-type: none"> <li>Glass</li> </ul>	+\$ 17	Specify with <i>glass</i> .
<b>Related Products</b>	<ul style="list-style-type: none"> <li>Paper</li> <li>Glass</li> </ul>		▶ See below ▶ Page 150

### Specification Information

Dimensions			Style	U.S.
D	W	H	Number	Base Price
25"	25"	23½"	<b>TS4TPT</b>	\$988

## Paper



	Standard Includes	Required to Specify
▶ Need help? Product details, page 139	<ul style="list-style-type: none"> <li>Paper: 44 sheets</li> </ul>	Style number

Related Products
<ul style="list-style-type: none"> <li>Paper table</li> </ul>

### Specification Information

Style Number	U.S. Price
<b>TS4TPTP</b>	\$132



**For Canadian Pricing**  
Multiply U.S. Price by the  
Canadian price factor.  
▶ See page 1 for details.

**Glass**



**Standard Includes** **Required to Specify**

- ▶ Need help? Product details, page 139
- Tempered glass
- Style number

**Related Products**

- Paper table ▶ Page 149

**Specification Information**

• Style Number	• U.S. Price
TS4TPTG	\$149



**For Canadian Pricing**  
Multiply U.S. Price by the Canadian price factor.  
▶ See page 1 for details.

Standard Includes	Required to Specify
<ul style="list-style-type: none"> <li>▶ Need help? Product details, page 137</li> <li>• Mesh screen: T615 Sultry Smoke</li> <li>• Frame: 0835 Black paint</li> <li>• Ships ready to assemble</li> </ul>	<ul style="list-style-type: none"> <li>1 Style number</li> <li>2 Fabric color number for mesh screen</li> <li>▶ See <i>Surface Materials</i>, page 159.</li> </ul>

Related Products
<ul style="list-style-type: none"> <li>• Big Lamp ▶ Page 146</li> <li>• Big Lounge ▶ Page 152</li> </ul>

Specification Information		
• Dimensions	• Style	• U.S.
H	Number	Price

## Screens

### Right-Hand

54"	<b>TS4TSCRNR</b>	\$974
:	:	:

### Left-Hand

54"	<b>TS4TSCRNL</b>	\$974
:	:	:

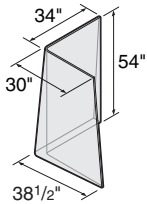
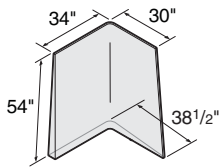

 **For Canadian Pricing**  
 Multiply U.S. Price by the Canadian price factor.  
 ▶ See page 1 for details.

# Big Lounge

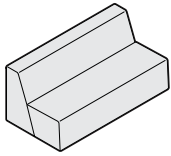

Standard Includes	Required to Specify
<ul style="list-style-type: none"> <li>▶ Need help? Product details, page 137</li> <li>Fully upholstered armless lounge: fabric price group 1</li> <li>Foot: black plastic</li> <li>Shipped fully assembled</li> <li>Meets Cal. 117 requirements</li> </ul>	<ul style="list-style-type: none"> <li>1 Style number</li> <li>2 Fabric color number for upholstery</li> <li>3 Options, if selected (see below)</li> <li>▶ See <i>Surface Materials</i>, page 159.</li> </ul>

Surface Materials	Options	U.S. Price	Required to Specify	
	<b>Single upholstery fabric</b>			
	• Fabric price group 1	No cost	Specify fabric color number.	
	• Fabric price group 2	+\$ 37	Specify fabric color number.	
	• Fabric price group 3	+\$ 144	Specify fabric color number.	
	• Fabric price group 4	+\$ 257	Specify fabric color number.	
	• Fabric price group 5	+\$ 461	Specify fabric color number.	
	• Fabric price group 6	+\$ 483	Specify fabric color number.	
	• Fabric price group 7	+\$ 556	Specify fabric color number.	
	• Fabric price group 8	+\$ 790	Specify fabric color number.	
	• Fabric price group 9	+\$ 965	Specify fabric color number.	
	• Fabric price group 10	+\$1011	Specify fabric color number.	
	• Customer's Own Material (COM)	+\$ 36	▶ See <i>Understanding Customer's Own Material (COM)</i> , page 324.	
		<b>Multiple upholstery fabric</b>		
		• Different fabric on seat and back	+\$ 63	Add suffix <b>M</b> to Big Lounge chair style number and select fabric color number for: 1 Seat, 2 Back

Example: TS3BC with T015 on seat and T016 on back.

Tip: Big Lounge is available with multiple fabrics.  
▶ See at right to specify.

Tip: When specifying multiple COM fabrics, indicate all surfaces where COM applies.  
Example: TS3BCM with Designtex 1234 on seat and Designtex 5678 on back.

	<b>① Fabric on seat</b>		
	• Fabric price group 1	No cost	Specify fabric color number.
	• Fabric price group 2	+\$ 15	Specify fabric color number.
	• Fabric price group 3	+\$ 62	Specify fabric color number.
	• Fabric price group 4	+\$ 111	Specify fabric color number.
	• Fabric price group 5	+\$ 199	Specify fabric color number.
	• Fabric price group 6	+\$ 207	Specify fabric color number.
	• Fabric price group 7	+\$ 238	Specify fabric color number.
	• Fabric price group 8	+\$ 339	Specify fabric color number.
	• Fabric price group 9	+\$ 414	Specify fabric color number.
	• Fabric price group 10	+\$ 434	Specify fabric color number.
	• Customer's Own Material (COM)	+\$ 16	▶ See <i>Understanding Customer's Own Material (COM)</i> , page 324.
	<b>② Fabric on back</b>		
	• Fabric price group 1	No cost	Specify fabric color number.
	• Fabric price group 2	+\$ 25	Specify fabric color number.
	• Fabric price group 3	+\$ 99	Specify fabric color number.
	• Fabric price group 4	+\$ 180	Specify fabric color number.
	• Fabric price group 5	+\$ 327	Specify fabric color number.
	• Fabric price group 6	+\$ 342	Specify fabric color number.
	• Fabric price group 7	+\$ 395	Specify fabric color number.
	• Fabric price group 8	+\$ 563	Specify fabric color number.
	• Fabric price group 9	+\$ 689	Specify fabric color number.
	• Fabric price group 10	+\$ 719	Specify fabric color number.
	• Customer's Own Material (COM)	+\$ 19	▶ See <i>Understanding Customer's Own Material (COM)</i> , page 324.

Related Products		
	• Ottoman	▶ Page 155

Specification Information				
• Dimensions			• Style	• U.S.
D	W	H	Number	Base Price
32"	66"	29"	<b>TS3BC</b>	\$2635



**For Canadian Pricing**  
Multiply U.S. Price by the Canadian price factor.  
▶ See page 1 for details.

# Half Lounge, Wedge, and Ottoman

Half Lounge, Wedge,  
and Ottoman

## Half Lounge

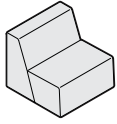

Standard Includes	Required to Specify
<ul style="list-style-type: none"> <li>▶ Need help? Product details, page 138</li> <li>• Fully upholstered armless lounge: fabric price group 1</li> <li>• Foot: black plastic</li> <li>• Shipped fully assembled</li> <li>• Meets Cal. 117 requirements</li> </ul>	<ul style="list-style-type: none"> <li>1 Style number</li> <li>2 Fabric color number for upholstery</li> <li>3 Options, if selected (see below)</li> <li>▶ See <i>Surface Materials</i>, page 159.</li> </ul>

Surface Materials	Options	U.S. Price	Required to Specify
	<b>Single upholstery fabric</b> <ul style="list-style-type: none"> <li>• Fabric price group 1</li> <li>• Fabric price group 2</li> <li>• Fabric price group 3</li> <li>• Fabric price group 4</li> <li>• Fabric price group 5</li> <li>• Fabric price group 6</li> <li>• Fabric price group 7</li> <li>• Fabric price group 8</li> <li>• Fabric price group 9</li> <li>• Fabric price group 10</li> <li>• Customer's Own Material (COM)</li> </ul>	No cost +\$ 19 +\$ 65 +\$139 +\$245 +\$264 +\$278 +\$399 +\$466 +\$493 +\$ 36	Specify fabric color number. Specify fabric color number. Specify fabric color number. Specify fabric color number. Specify fabric color number. Specify fabric color number. Specify fabric color number. Specify fabric color number. Specify fabric color number. Specify fabric color number. Specify fabric color number. ▶ See <i>Understanding Customer's Own Material (COM)</i> , page 324.

Example: TS3HL with T015 on seat and T016 on back.

Tip: Half Lounge is available with multiple fabrics.  
▶ See at right to specify.

Tip: When specifying multiple COM fabrics, indicate all surfaces where COM applies.  
Example: TS3HLM with Designtex 1234 on seat and Designtex 5678 on back.

	<b>Multiple upholstery fabric</b> <ul style="list-style-type: none"> <li>• Different fabric on seat and back</li> </ul>	+\$ 63	Add suffix <b>M</b> to Half Lounge chair style number and select fabric color number for: 1 Seat, 2 Back
	<b>1 Fabric on seat</b> <ul style="list-style-type: none"> <li>• Fabric price group 1</li> <li>• Fabric price group 2</li> <li>• Fabric price group 3</li> <li>• Fabric price group 4</li> <li>• Fabric price group 5</li> <li>• Fabric price group 6</li> <li>• Fabric price group 7</li> <li>• Fabric price group 8</li> <li>• Fabric price group 9</li> <li>• Fabric price group 10</li> <li>• Customer's Own Material (COM)</li> </ul>	No cost +\$ 11 +\$ 25 +\$ 56 +\$ 83 +\$153 +\$167 +\$177 +\$245 +\$272 +\$ 16	Specify fabric color number. Specify fabric color number. Specify fabric color number. Specify fabric color number. Specify fabric color number. Specify fabric color number. Specify fabric color number. Specify fabric color number. Specify fabric color number. Specify fabric color number. ▶ See <i>Understanding Customer's Own Material (COM)</i> , page 324.
	<b>2 Fabric on back</b> <ul style="list-style-type: none"> <li>• Fabric price group 1</li> <li>• Fabric price group 2</li> <li>• Fabric price group 3</li> <li>• Fabric price group 4</li> <li>• Fabric price group 5</li> <li>• Fabric price group 6</li> <li>• Fabric price group 7</li> <li>• Fabric price group 8</li> <li>• Fabric price group 9</li> <li>• Fabric price group 10</li> <li>• Customer's Own Material (COM)</li> </ul>	No cost +\$ 16 +\$ 50 +\$ 95 +\$167 +\$172 +\$182 +\$278 +\$300 +\$305 +\$ 16	Specify fabric color number. Specify fabric color number. Specify fabric color number. Specify fabric color number. Specify fabric color number. Specify fabric color number. Specify fabric color number. Specify fabric color number. Specify fabric color number. Specify fabric color number. Specify fabric color number. ▶ See <i>Understanding Customer's Own Material (COM)</i> , page 324.

Specification Information				
• Dimensions			• Style	• U.S.
D	W	H	Number	Base Price
32"	33"	29"	TS3HL	\$1519

**For Canadian Pricing**  
Multiply U.S. Price by the Canadian price factor.  
▶ See page 1 for details.

**Wedge**

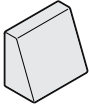

Standard Includes	Required to Specify
<ul style="list-style-type: none"> <li>Fully upholstered wedge: fabric price group 1</li> <li>Foot: black plastic</li> <li>Deck stitch detail</li> <li>Connecting hardware</li> </ul>	<ul style="list-style-type: none"> <li>1 Style number</li> <li>2 Fabric color number for upholstery</li> <li>3 Options, if selected (see below)</li> <li>▶ See <i>Surface Materials</i>, page 247.</li> </ul>

		Options	U.S. Price	Required to Specify
<b>Surface Materials</b>	<b>Upholstery</b>			
		• Fabric price group 1	No cost	Specify fabric color number.
		• Fabric price group 2	+\$ 15	Specify fabric color number.
		• Fabric price group 3	+\$ 40	Specify fabric color number.
		• Fabric price group 4	+\$ 67	Specify fabric color number.
		• Fabric price group 5	+\$106	Specify fabric color number.
		• Fabric price group 6	+\$177	Specify fabric color number.
		• Fabric price group 7	+\$221	Specify fabric color number.
		• Fabric price group 8	+\$245	Specify fabric color number.
		• Fabric price group 9	+\$288	Specify fabric color number.
		• Fabric price group 10	+\$327	Specify fabric color number.
	• Customer's Own Material (COM)	+\$ 36	▶ See <i>Understanding Customer's Own Material (COM)</i> , page 324.	

Specification Information	
•Style Number	•U.S. Base Price
TS3WG	\$909
•	•



**For Canadian Pricing**  
 Multiply U.S. Price by the Canadian price factor.  
 ▶ See page 1 for details.

## Ottoman



Standard Includes	Required to Specify
<ul style="list-style-type: none"> <li>Fully upholstered ottoman: fabric price group 1</li> <li>Four adjustable-height legs: brushed aluminum</li> <li>Meets Cal. 117 requirements</li> </ul>	<ul style="list-style-type: none"> <li>1 Style number</li> <li>2 Fabric color number for upholstery</li> <li>3 Options, if selected (see below)</li> <li>▶ See <i>Surface Materials</i>, page 247</li> </ul>

	Options	U.S. Price	Required to Specify
<b>Surface Materials</b>	<b>Upholstery</b>		
	• Fabric price group 1	No cost	Specify fabric color number.
	• Fabric price group 2	+\$ 16	Specify fabric color number.
	• Fabric price group 3	+\$ 41	Specify fabric color number.
	• Fabric price group 4	+\$ 60	Specify fabric color number.
	• Fabric price group 5	+\$ 77	Specify fabric color number.
	• Fabric price group 6	+\$ 95	Specify fabric color number.
	• Fabric price group 7	+\$113	Specify fabric color number.
	• Fabric price group 8	+\$144	Specify fabric color number.
	• Fabric price group 9	+\$178	Specify fabric color number.
	• Fabric price group 10	+\$202	Specify fabric color number.
• Customer's Own Material (COM)	+\$ 36	▶ See <i>Understanding Customer's Own Material (COM)</i> , page 324.	
	<b>Legs</b>		
	• Solid maple wood legs	+\$ 34	Specify with <i>solid maple wood legs</i> and select 3412 Natural Cherry, 3522 Clear Maple, or 3762 Dark Walnut.
<b>Glides</b>	• Low profile glide	No cost	Specify with <i>low profile glides</i> .

*Tip: The ottoman must be specified with low profile glides.*

Specification Information	
• Style Number	• U.S. Base Price
TS34401	\$515
.	.
.	.



**For Canadian Pricing**  
Multiply U.S. Price by the Canadian price factor.  
▶ See page 1 for details.

# Slim Table, Skate Table, and Footrest

## Slim Table

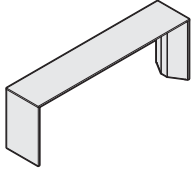

Standard Includes	Required to Specify
<ul style="list-style-type: none"> <li>▶ Need help? Product details, page 140</li> <li>• 1/2" thick top and sides: Low-Pressure Laminate</li> <li>• 1 mm radius edge band on top and sides</li> <li>• Two simplex receptacles: grey plastic</li> <li>• 15-amp power cord: black plastic</li> <li>• Steel frame: paint</li> <li>• Self-leveling glides</li> <li>• Shipped ready to assemble</li> </ul>	<ul style="list-style-type: none"> <li>1 Style number</li> <li>2 Laminate color number for top and sides</li> <li>3 Paint color number for steel frame</li> <li>4 Options, if selected (see below)</li> <li>▶ See <i>Surface Materials</i>, page 159.</li> </ul>

Surface Materials	Options	U.S. Price	Required to Specify
	<b>Top</b> <ul style="list-style-type: none"> <li>• Low-Pressure Laminate</li> <li>• Open Line laminate</li> </ul>	No cost +\$ 67 plus cost of laminate	<ul style="list-style-type: none"> <li>▶ See <i>Surface Materials Reference Manual</i>.</li> <li>▶ See <i>Surface Materials Reference Manual</i>.</li> </ul>
	<ul style="list-style-type: none"> <li>• High-Pressure Laminate</li> <li>• Veneer</li> </ul>	+\$179 +\$395	<ul style="list-style-type: none"> <li>▶ See <i>Surface Materials Reference Manual</i>. Specify with 3611 Natural Oak.</li> </ul>
	<b>Edge (High-Pressure Laminate only)</b> <ul style="list-style-type: none"> <li>• Plastic</li> </ul>	No cost	Select plastic color number.

Tip: High-Pressure laminate requires plastic on edge.

Tip: High-Pressure Laminate on the Campfire Slim Table and Campfire Skate Table will be shipped in 20 business days after receipt of a clean order. Products are typically delivered within 25 business days.

Related Products	
<ul style="list-style-type: none"> <li>• Big Lounge</li> <li>• Half Lounge</li> <li>• Skate Table</li> <li>• Footrest</li> </ul>	<ul style="list-style-type: none"> <li>▶ Page 152</li> <li>▶ Page 153</li> <li>▶ Page 157</li> <li>▶ Page 157</li> </ul>

Specification Information				
• Dimensions			• Style	• U.S.
D	W	H	Number	Base Price
14"	66"	23"	<b>TS4TPST</b>	\$878



**For Canadian Pricing**  
 Multiply U.S. Price by the Canadian price factor.  
 ▶ See page 1 for details.

## Skate Table



Standard Includes		Required to Specify
▶ Need help? Product details, page 140	<ul style="list-style-type: none"> <li>• 1/2" thick top and sides: Low-Pressure Laminate</li> <li>• 3 mm radius edge band on top</li> <li>• Steel base: paint</li> <li>• Cord grommet: 6527 Merle</li> <li>• Glides: 6527 Merle</li> <li>• Skate wheels: 6527 Merle</li> <li>• Shipped ready to assemble</li> </ul>	1 Style number 2 Laminate color number for top 3 Paint color number for steel base 4 Options, if selected (see below) ▶ See <i>Surface Materials</i> , page 159.

Tip: High-Pressure Laminate requires plastic on edge.

Tip: High-Pressure Laminate on the Campfire Slim Table and Campfire Skate Table will be shipped in 20 business days after receipt of a clean order. Products are typically delivered within 25 business days.

Options	U.S. Price	Required to Specify
<b>Surface Materials</b> <b>Top</b> <ul style="list-style-type: none"> <li>• Low-Pressure Laminate</li> <li>• Open Line laminate</li> <li>• High-Pressure Laminate</li> <li>• Veneer</li> </ul>	No cost +\$67 plus cost of laminate +\$72 +\$95	▶ See <i>Surface Materials Reference Manual</i> . ▶ See <i>Surface Materials Reference Manual</i> . ▶ See <i>Surface Materials Reference Manual</i> . Specify with 3611 Natural Oak.
<b>Edge (High-Pressure Laminate only)</b> <ul style="list-style-type: none"> <li>• Plastic</li> </ul>	No cost	Select plastic color number.

Related Products	
<ul style="list-style-type: none"> <li>• Big Lounge</li> <li>• Half Lounge</li> <li>• Slim Table</li> <li>• Footrest</li> </ul>	▶ Page 152 ▶ Page 153 ▶ Page 156 ▶ Page 157

Specification Information				
Dimensions			Style	U.S.
D	W	H	Number	Base Price
18"	22"	24 <sup>7</sup> / <sub>8</sub> "	TS4TST	\$442

Campfire

## Footrest



Standard Includes		Required to Specify
▶ Need help? Product details, page 140	<ul style="list-style-type: none"> <li>• Footrest: grey expanded polypropylene foam</li> <li>• Band: 3 mm plastic</li> </ul>	1 Style number 2 Plastic color number for band ▶ See <i>Surface Materials</i> , page 159.

Related Products	
<ul style="list-style-type: none"> <li>• Big Lounge</li> <li>• Half Lounge</li> <li>• Slim Table</li> <li>• Skate Table</li> </ul>	▶ Page 152 ▶ Page 153 ▶ Page 156 ▶ Page 157

Specification Information				
Dimensions			Style	U.S.
D	W	H	Number	Price
16 <sup>5</sup> / <sub>8</sub> "	16 <sup>1</sup> / <sub>4</sub> "	11"	TS3FR	\$198

 **For Canadian Pricing**  
 Multiply U.S. Price by the Canadian price factor.  
 ▶ See page 1 for details.

# Accessories

## Vertical Cord Cover



Standard Includes	Required to Specify
-------------------	---------------------

- |   |              |
|---|--------------|
| <ul style="list-style-type: none"> <li>Vertical cord cover: black plastic</li> <li>Attachment hardware</li> </ul> | Style number |
|---|--------------|

Related Products
------------------

- |  |
|--|
| <ul style="list-style-type: none"> <li>Big Table <span style="float: right;">▶ Page 142</span></li> <li>Big Table with trough <span style="float: right;">▶ Page 143</span></li> </ul> |
|--|

Specification Information		
---------------------------	--	--

Length	Style Number	U.S. Price
28"	<b>TS4TVWM28</b>	\$24
40"	<b>TS4TVWM40</b>	\$35

## Receptacles



Standard Includes	Required to Specify
-------------------	---------------------

- |   |              |
|---|--------------|
| <ul style="list-style-type: none"> <li>Receptacle: anodized aluminum</li> <li>Attachment hardware</li> <li>10' electrical cord</li> </ul> | Style number |
|---|--------------|

Related Products
------------------

- |   |
|---|
| <ul style="list-style-type: none"> <li>Big Table with trough <span style="float: right;">▶ Page 143</span></li> </ul> |
|---|

Specification Information	
---------------------------	--

Style Number	U.S. Price
--------------	------------

### Dual Pop-Up Receptacle, Power on Each End

<b>TS4TPWR</b>	\$733
----------------	-------

### Dual Pop-Up Receptacle, One Power and One Data Port on Each End

<b>TS4TPWRD</b>	\$733
-----------------	-------

### Dual Pop-Up Receptacle on One End

<b>TS4TPWR1</b>	\$267
-----------------	-------

### Dual Pop-Up Receptacle, One Power, One Data Port on One End

<b>TS4TPWRD1</b>	\$267
------------------	-------

*Tip: Pop-up receptacles come with a 10' cord.*

▶ See Understanding page 132 to understand price differences between power options.



**For Canadian Pricing**  
 Multiply U.S. Price by the Canadian price factor.  
 ▶ See page 1 for details.

# Surface Materials

► For Surface Materials matrices for all product lines, see page 305

## Paint

Applies to:

- Big Table Trough
- 4799 Platinum Metallic

Applies to:

- Big Lamp base
- Slim Table frame
- Skate Table base
- 4140 Arctic White
- 4799 Platinum Metallic
- 7246 Midnight Metallic

## Plastic

Applies to:

- Footrest
- 6009 Arctic White
- 6333 Picasso
- 6335 Wasabi
- 6338 Chili
- 6527 Merle

Applies to:

- Slim Table
- Skate Table
- 6000 Black
- 6001 Coffee
- 6009 Arctic White
- 6034 Natural Cherry
- 6036 Medium Cherry
- 6037 Winter on Maple
- 6038 Blonde on Maple
- 6041 Natural Walnut
- 6045 Medium Mahogany on Walnut **E**
- 6052 Milk
- 6053 Seagull
- 6213 Acacia
- 6219 Clear Oak
- 6231 Graphite Walnut
- 6234 Clear Cherry
- 6237 Clear Maple
- 6242 Virginia Walnut
- 6243 Blackwood
- 6245 Clear Walnut
- 6246 Warm Oak **E**
- 6249 Platinum Solid
- 6615 Grey Value 5
- 6619 Ice **E**
- 6631 Cream
- 6635 Dawn **E**
- 6636 Mist
- 6654 Sand
- 6655 Warm White
- 6676 Marbled Maple
- 6677 Chocolate Walnut
- 6678 Marbled Cherry

*Tip: Established finishes are available for delivery in 15 business days.*

**E** = Established

## Laminate

### Low-Pressure Laminate

Applies to:

- Mobile Storage Cabinet
- Mobile Storage Cabinet with wardrobe
- 25L5 Virginia Walnut
- 25L6 Blackwood
- 25L8 Clear Walnut
- 25L9 Warm Oak **E**
- 26L1 Natural Cherry
- 2L30 Arctic White
- 2L85 Dune
- 2LAT Acacia

Applies to:

- Big Table
- Table drawer
- Slim Table top and sides
- Skate Table top
- 25L5 Virginia Walnut
- 25L6 Blackwood
- 25L8 Clear Walnut
- 25L9 Warm Oak **E**
- 26L1 Natural Cherry
- 2L30 Arctic White

### High-Pressure Laminate

Applies to:

- Paper Table
- 2535 Virginia Walnut
- 2536 Blackwood
- 2538 Clear Walnut
- 2539 Warm Oak **E**

Applies to:

- Slim Table
- Skate Table

### Fiber Laminate

- 2850 Vanadium Fiber
- 2851 Rhyme Fiber **E**
- 2852 Tungsten Fiber
- 2854 Vellum Fiber
- 2859 Novell Fiber
- 2860 Granite Fiber
- 2861 Coconut Fiber
- 2862 Stucco Fiber

### Micro Laminate

- 2920 Marl Micro
- 2921 Gypsum Micro
- 2922 Clay Micro
- 2923 Shadow Micro **E**

### Patina Laminate

- 2870 Blonde Bronze Patina
- 2871 Blackened Bronze Patina
- 2873 Instant Iron Patina

## Solid Laminate

- 2722 Cream **E**
- 2730 Arctic White
- 2746 Black
- 2759 Warm White **E**
- 2811 Mist **E**
- 2883 Seagull
- 2884 Milk
- 2885 Dune

## Speckle Laminate

- 2820 Coffee Speckle
- 2822 Woodrose Speckle **E**
- 2823 Driftwood Speckle
- 2824 Smoke Speckle
- 2825 Vanadium Speckle

## Woodgrain Laminate

- 2406 Clear Cherry
- 2409 Clear Maple
- 2410 Graphite Walnut
- 2412 Natural Cherry
- 2422 Medium Cherry
- 2511 Winter on Maple
- 2538 Clear Walnut
- 2539 Warm Oak **E**
- 2592 Blonde on Maple
- 2714 Natural Walnut
- 2772 Medium Mahogany on Walnut **E**
- 2HAK Clear Oak
- 2HAT Acacia

## Turnstone Laminate Collection

- 2535 Virginia Walnut
- 2536 Blackwood
- 2612 Marbled Maple
- 2614 Chocolate Walnut
- 2615 Marbled Cherry

## Fabric

Applies to:

- Big Lamp shade
- 5F19 Regis Cinder **T**
- 5S24 Cogent: Connect Nickel

## Mesh

Applies to:

- Screen
- T615 Sultry Smoke

## Wood

Applies to:

- Personal Table
- Slim Table top and sides
- Skate Table top
- 3611 Natural Oak

## Upholstery

Not every upholstery is available on every chair. Please refer to the upholstery matrix on page 323 before specifying.

### Price Group 1

- Buzz2
- Jacks **E**
- Link
- Playground **E**

### Price Group 2

- Cogent: Connect
- Cogent: Geode Seating **E**
- Cogent: Geode Vertical **E**
- Cogent: Trails
- Crosswalk **E**
- Nitelights
- Seating Vinyl **E**
- Spyder **E**
- Stand In
- Zoe2 **E**

### Price Group 3

- Gaja – C2C
- Imperma
- Redeem
- Retrieve
- Texel

### Price Group 5

- Bo Peep
- Remix

### Price Group 6

- Brisa

## Select Surfaces

**For information on products within Select Surfaces,** including accent paints and fabrics from Designtex, Gabriel, Kvadrat, and Pollack, please refer to the *Surface Materials Reference Manual* or visit [Steelcase.com/selectsurfaces](http://Steelcase.com/selectsurfaces).

## Custom Surfaces

### Price Group COM (Customer's Own Material)

### Fabric Approval and Yardage

To confirm whether a particular COM material has already been tested for use on a specific Steelcase product or to determine actual yardage requirements:

- Visit [www.steelcase.com](http://www.steelcase.com)

### For additional information regarding Customer's Own Material, call

1.888.STEELCASE (1.888.783.3522) or send an e-mail to [lineone@steelcase.com](mailto:lineone@steelcase.com).

### Customer's Own Material (COM) Program

The Customer's Own Material (COM) program offers the opportunity for customers to select fabrics that are not offered through the standard Steelcase surface materials program for use on Steelcase products. Once approved, you can place your order. Steelcase will facilitate the entire ordering process and give you a production schedule. Steelcase will order the COM fabric directly from the textile manufacturer. For up-to-date information regarding fabric test results for all COM fabrics and details regarding yardage requirements for most seating lines, visit the COM website on [www.steelcase.com](http://www.steelcase.com). COMs are not covered under the Steelcase warranty.

### Soil Retardants

Soil retardants are treatments that provide long-term soil and stain resistance to a fabric without affecting the shade or the integrity of the fabric. The following Steelcase Textiles and turnstone Collection by Designtex fabrics are available pre-treated with soil retardant:

- Jacks
- Link
- Spyder



---

# Seating

*Tip: Established finishes are available for delivery in 15 business days.*

**E** = Established

---



## Statement of Line **162**



### Understanding and Specifying

#### Task Chairs

Reply Select	<b>167</b>
Jack	<b>173</b>

#### Multipurpose Seating

Buoy	<b>181</b>
Shortcut	<b>185</b>
cobi Select	<b>193</b>
Uno Select	<b>199</b>
Scoop	<b>205</b>

#### Lounge Seating

Jenny Lounge	<b>211</b>
Lincoln Lounge	<b>235</b>
alight Lounge	<b>241</b>



## Surface Materials **247**

# Statement of Line

Seating

## Reply Select



Task Chair  
with mesh back  
▶ Page 172

## Jack



Armless Task Chair  
▶ Page 178



Task Chair  
▶ Page 178

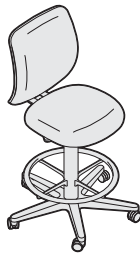

Armless Stool  
▶ Page 178



Stool  
▶ Page 178

## Buoy

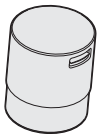

Multi-Purpose  
Seating  
▶ Page 184

## Shortcut



Multi-Purpose  
Chair  
▶ Page 190



Multi-Purpose  
Stool  
▶ Page 191

## cobi Select



Collaborative  
Chair with Arms  
▶ Page 198

## Uno Select



Multi-Purpose  
High-Back Chair  
▶ Page 203

## Scoop

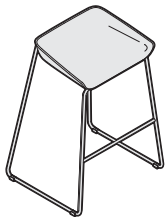

Stool  
▶ Page 208

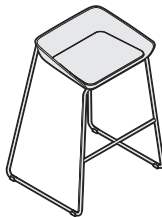

Stool with  
Upholstered Seat  
▶ Page 208

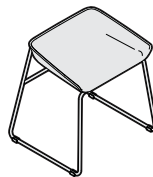

Side Chair  
▶ Page 209

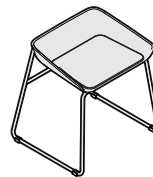

Side Chair with  
Upholstered Seat  
▶ Page 209

**Jenny Lounge**

*Tip: Jenny armless lounge chairs shown comprise full statement of line.*

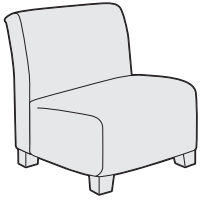

Armless Lounge Chair  
▶ Page 216

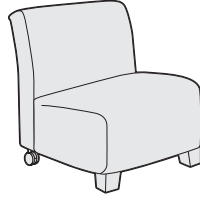

Armless Lounge Chair with Casters  
▶ Page 216

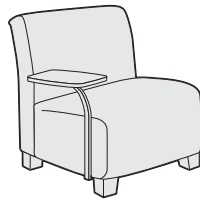

Armless Lounge Chair with Tablet Arm  
▶ Page 216

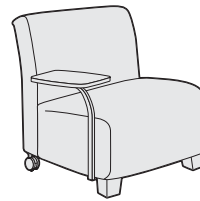

Armless Lounge Chair with Casters and Tablet Arm  
▶ Page 216

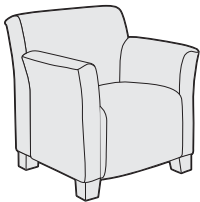

\*Lounge Chair with Arms  
▶ Page 218

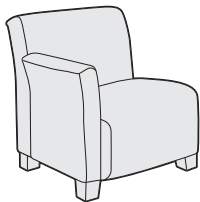

\*Lounge Chair with Arm Right  
▶ Page 220

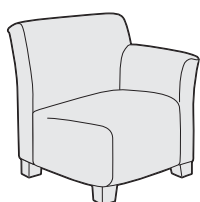

\*Lounge Chair with Arm Left  
▶ Page 220

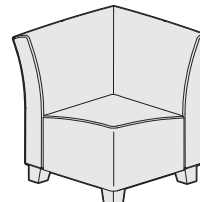

\*Corner Lounge Chair  
▶ Page 224

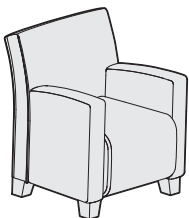

\*Club Lounge Chair  
▶ Page 226

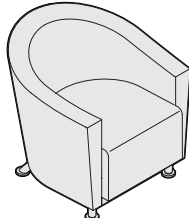

Round Lounge Chair  
▶ Page 228

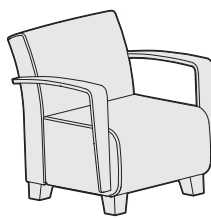

\*Lounge Chair with Wood Arms  
▶ Page 230

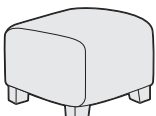

\*Ottoman  
▶ Page 232

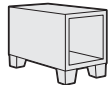

End Table  
▶ Page 234

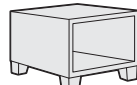

Coffee Table  
▶ Page 234

\*See specifying pages for availability of casters and tablet arm.

---

## Lincoln Lounge

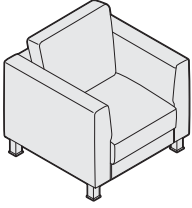

Lincoln Lounge  
▶ Page 240

---

## alight Lounge

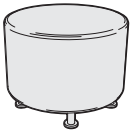

Round Ottoman  
▶ Page 245

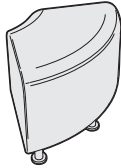

Corner Ottoman  
▶ Page 245

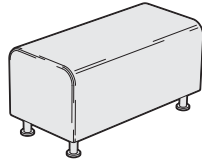

Bench Ottoman  
▶ Page 245

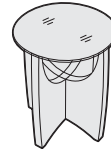

End Table  
▶ Page 246



Coffee Table  
▶ Page 246



---

# Understanding and Specifying Reply Select Task Chair



## Product Details

Reply Select	168
Dimensions	170



## Specifying

Reply Select	172
--------------	-----

# Reply Select

**Reply Select** is a complete family of comfortable, budget-friendly chairs that are as nice to look at as they are to sit in. Reply can take on whatever your workday brings.

▶ Specifying, page 172

**Back handle** provides a convenient handhold to easily move the chair.

**Lumbar height** adjusts 4" to provide additional lower back support and is available as an option.

**Arm height** can adjust independently within a 3¾" range to help relieve upper back and shoulder fatigue.

**Five-arm base** is black plastic.

**Tilt tension adjustment** allows you to control the amount of resistance needed for reclining.



**Arms**, when specified, have a textured plastic arm cap.

**Multi-position back lock** allows user to lock the backrest in multiple positions.

**Seat depth** adjusts within a 1½" range to accommodate users of varying leg lengths.

**Seat height** adjusts within a 5" range with a pneumatic adjustment mechanism.

**Casters** have hard, dual-wheels that roll smoothly on carpets. They are 2½" for increased mobility. Soft, dual-wheel casters are available as an option for use on hard floors or chair mats.

## Product Details



**Synchro-tilt mechanism with a natural fluid motion on work chairs** keeps users oriented to their work.

**Cartoned** shipment of Reply work chairs is standard. Reply work chairs ship knocked down in a single carton consisting of four components: back, seat and mechanism, base, and pneumatic. This allows for shipment in a smaller carton. Assembly by a qualified dealer installer is required for work chairs. Assembly instructions are included. No additional tools are required for assembly.

## Adjustment Features

**Adjustability instructions** are included with every swivel-base chair. Instructions can also be found at [www.steelcase.com](http://www.steelcase.com).

### Seat Adjustments

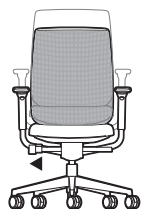

**Seat height** adjusts pneumatically. To lower, hold handle up while seated. To raise, hold handle up and keep your weight off the chair. Range of adjustability is 5", from 16"H to 21"H.

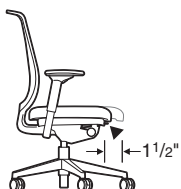

**Seat depth** adjusts 1/2" (15 1/4"–16 3/4") by pulling handle up. Slide seat forward or back to accommodate various leg lengths. Release handle to lock. Seat depth is a standard feature on work chairs.

### Back Adjustments

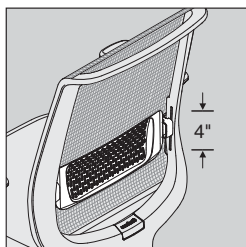

**Lumbar height** adjusts 4" (6" to 10" from seat) by grabbing exposed tabs and sliding the lumbar support up or down. Available as an option on mesh work chairs only.



Variable back lock  
Upright setting  
(4 positions)

**Multiple position back lock** allows users to recline the back to the desired angle and lock it in place. To lock, recline to desired angle and push back lock handle down. To release, lean forward, lift the handle and apply pressure to the back to disengage the lock.

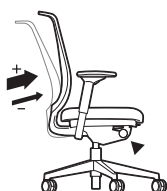

**Back tension** adjusts by turning knob forward to increase back tension, backward to decrease back tension. This feature is standard on all work chairs.

### Arm Adjustments

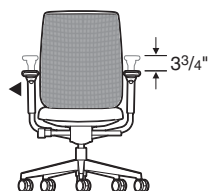

**Arm height** adjusts independently within a range of 3 3/4" (7 1/2"–11 1/4" from the seat). Push button on outside and under arm cap in while moving arms up or down. Releasing buttons locks arms in position.

### Other Features

**Soft-wheel casters for hard floors on work chairs** are available for specific applications.

## Surface Materials

▶ See surface materials on page 247 for specific availability or refer to the *Surface Materials Reference Manual* for further information.

### Upholstery

- Fabric
- Fabric with soil-retardant treatment (option)
- Mesh (back only)

### Hard components

- Chair with swivel-base (frame, outer back, arm cap assembly, and mechanism)
- 6205 Black

- Chair with swivel-base (arm tube and base)
- 6205 Black

### Casters

- 6205 Black

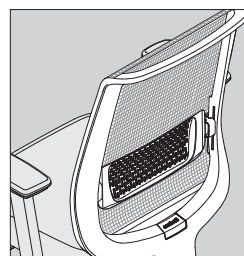

**Mesh back on swivel-base models** are available with a height-adjustable lumbar option to enhance back support.

**All Steelcase seating with standard upholstery fabrics** complies with requirements of the State of California Technical Bulletin 117. All standard seating is labeled to be in compliance with California 117.

## Programs & Services

**Local codes** may have special requirements for upholstery.

## Dimensions

▶ Page 170

# Dimensions

Reply Select

Features	Overall Depth	Width	Height	Seat Depth	Functional Seat Depth	Seat Width	Seat Height from Floor	Back Width	Back Height from Seat	Lumbar Height from Seat
----------	---------------	-------	--------	------------	-----------------------	------------	------------------------	------------	-----------------------	-------------------------

## Reply Select

### Swivel-Base Task Chairs

Mesh Back	24" to 25"	25 <sup>3</sup> / <sub>4</sub> "	37 <sup>3</sup> / <sub>4</sub> " to 42 <sup>3</sup> / <sub>4</sub> "	16 <sup>7</sup> / <sub>8</sub> "	16" to 17 <sup>1</sup> / <sub>2</sub> "	18 <sup>1</sup> / <sub>2</sub> "	16" to 21"	17 <sup>1</sup> / <sub>2</sub> "	22 <sup>5</sup> / <sub>8</sub> "	6" to 10"
-----------	------------	----------------------------------	--	----------------------------------	---	----------------------------------	------------	----------------------------------	----------------------------------	-----------

\*Armless models are 1<sup>1</sup>/<sub>4</sub>" narrower.

\*\*Dimension is 1/2" less when specified with glides.

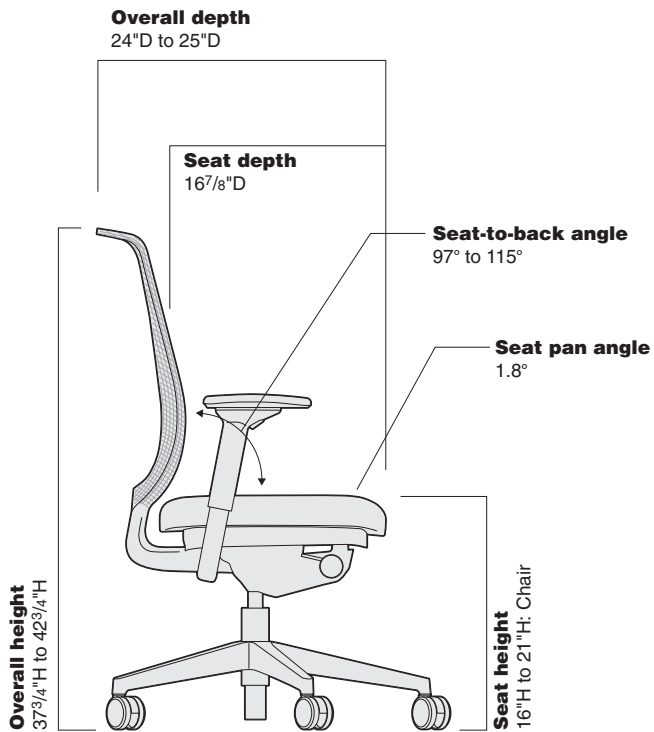
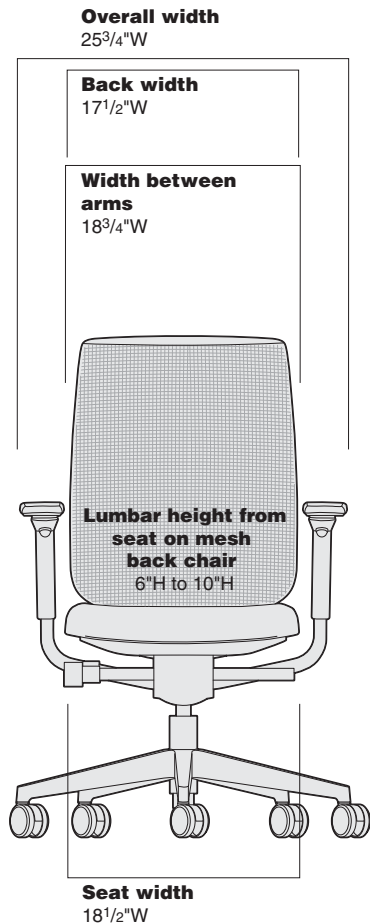

• Width • Between • Arms	• Arm • Height • to Floor	• Arm • Height • from • Seat	• Arm Cap • Pivot • Range	• Angle • Between • Seat and • Back	• Seat • Pan • Angle
--------------------------------	---------------------------------	---------------------------------------	---------------------------------	--	----------------------------

**Swivel-Base Work Chairs**

18¾"	23⅝" to 32"	7½" to 11¼"	18° inward, 4° outward	97° to 113°	1.8°
------	-------------	-------------	---------------------------	-------------	------

# Reply Select

Mesh Back with Standard Upholstery on Seat



Tip: Arms are not included with Reply Select unless you specify the arm options.

Tip: Outer back, mechanism, and optional arm cap assembly are available in 6205 Black only.

Standard Includes		Required to Specify
<ul style="list-style-type: none"> <li>▶ Need help? Product details, page 168</li> </ul>	<ul style="list-style-type: none"> <li>• Synchro-tilt mechanism</li> <li>• 5" pneumatic seat-height adjustment (16"–21")</li> <li>• Multi-position back lock</li> <li>• Outer back, seat shell, and five-arm plastic base: plastic</li> <li>• 1½" seat depth adjustment</li> <li>• Mesh on back</li> <li>• Standard upholstery design on seat: Buzz2 fabric only</li> <li>• 2½"-diameter, hard-composition, dual-wheel casters: black</li> </ul>	<ul style="list-style-type: none"> <li>1 Style number</li> <li>2 Mesh color number for back</li> <li>3 Options, if selected (see below)</li> <li>▶ See <i>Surface Materials</i>, page 247.</li> </ul>

Options	U.S. Price	Required to Specify
<b>Arms</b>	• Height-adjustable arms, soft arm caps +\$117	Specify with height-adjustable arms.
<b>Lumbar Height</b>	• 4" travel for additional lumbar support +\$ 48	Specify with adjustable lumbar height.
<b>Casters</b>	• Soft, dual-wheel casters for use on hard floors +\$ 30	Specify with soft casters.

Specification Information	
Style Number	U.S. Base Price
TS466EXP	\$884

▶ Detailed dimensions, page 170



**For Canadian Pricing**

Multiply U.S. Price by the Canadian price factor.

▶ See page 1 for details.

---

# Understanding and Specifying Jack Task Chair



## Product Details

Jack	174
Dimensions	176



## Specifying

Jack	178
------	-----

# Jack

**Jack** is a complete family of comfortable, budget-friendly chairs that are as nice to look at as they are to sit in. Jack can take on whatever your workday brings.

► Specifying, page 178

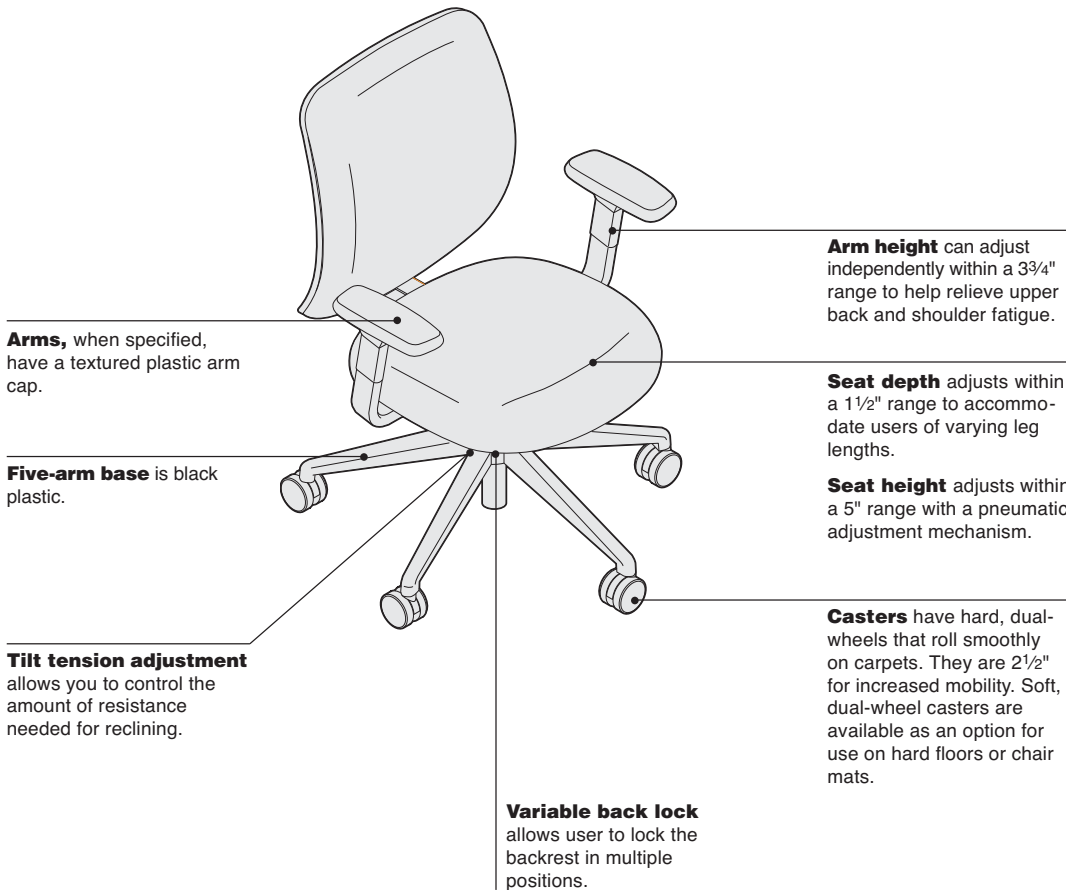

## Adjustment Features



**Variable back lock** adjusts by pulling lever forward and leaning back to desired angle. Push lever back to lock into position. To release for tilt, push lever forward and lean back.

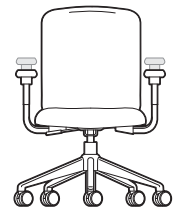

**Arm height** adjusts by pushing trigger up and holding, pull arm up or push down and release trigger to lock.



**Maintenance arm width** adjusts by loosening screws under arm bracket, adjusting arm in or out, and tightening screws.



**Seat depth** adjusts by lifting lever up and holding, shift seat forward or back, and release lever to lock.

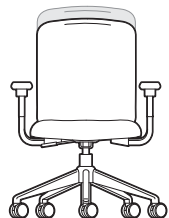

**Back height** adjusts by grabbing chair back with both hands and slowly pulling up to desired height. To lower back, pull up to highest position, and back will drop to lowest position. Reset mechanism by pushing down firmly, then adjust upward.

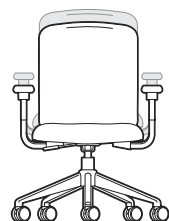

**Pneumatic seat height** adjusts by lifting body weight up and pulling lever. To lower chair, remain seated and pull lever up.



**Tilt tension** adjusts by turning counterclockwise to decrease. Turn clockwise to increase.

### Surface Materials

▶ See surface materials on page 305 for specific availability or refer to the *Surface Materials Reference Manual* for further information.

### Upholstery

- Fabric
- Fabric with soil-retardant treatment (option)

### Hard components

- Chair (frame, outer back, T-arms, and five arm base)
- 6205 Black

### Casters

- 6205 Black

**All Steelcase seating with standard upholstery fabrics** complies with requirements of the State of California Technical Bulletin 117. All standard seating is labeled to be in compliance with California 117.

### Programs & Services

**Local codes** may have special requirements for upholstery.

### Dimensions

▶ Page 176

# Dimensions

## Jack

Features	Overall Depth	Width	Height	Functional Seat Depth	Adjustable Seat Depth	Seat Width	Seat Height from Floor	Back Width	Back Height from Seat	Seat Pan Angle
<b>Jack</b>										
<b>With swivel-only mechanism</b>										
	27 <sup>3</sup> / <sub>4</sub> "	27 <sup>3</sup> / <sub>4</sub> "	34 <sup>7</sup> / <sub>8</sub> "– 39 <sup>5</sup> / <sub>8</sub> "	17 <sup>1</sup> / <sub>4</sub> "	N.A.	18 <sup>1</sup> / <sub>2</sub> "	15 <sup>3</sup> / <sub>4</sub> "– 20 <sup>1</sup> / <sub>2</sub> "	17 <sup>1</sup> / <sub>2</sub> "	21"	2 <sup>1</sup> / <sub>2</sub> °
<b>With swivel-tilt mechanism</b>										
	27 <sup>3</sup> / <sub>4</sub> "	27 <sup>3</sup> / <sub>4</sub> "	34 <sup>7</sup> / <sub>8</sub> "– 39 <sup>5</sup> / <sub>8</sub> "	17 <sup>1</sup> / <sub>4</sub> "	N.A.	18 <sup>1</sup> / <sub>2</sub> "	15 <sup>3</sup> / <sub>4</sub> "– 20 <sup>1</sup> / <sub>2</sub> "	17 <sup>1</sup> / <sub>2</sub> "	21"	–2°
<b>With synchro-tilt mechanism</b>										
	27 <sup>3</sup> / <sub>4</sub> "	27 <sup>3</sup> / <sub>4</sub> "	34 <sup>7</sup> / <sub>8</sub> "– 43 <sup>3</sup> / <sub>4</sub> "	17 <sup>1</sup> / <sub>8</sub> "	N.A.	18 <sup>1</sup> / <sub>2</sub> "	15 <sup>1</sup> / <sub>4</sub> "– 20"	17 <sup>1</sup> / <sub>2</sub> "	19 <sup>11</sup> / <sub>16</sub> "– 21 <sup>11</sup> / <sub>16</sub> "	–2°
<b>With synchro-tilt mechanism and seat depth adjustment</b>										
	27 <sup>3</sup> / <sub>4</sub> "	27 <sup>3</sup> / <sub>4</sub> "	35 <sup>1</sup> / <sub>8</sub> "– 43 <sup>1</sup> / <sub>8</sub> "	N.A.	16"–17 <sup>3</sup> / <sub>4</sub> "	18 <sup>1</sup> / <sub>2</sub> "	17 <sup>1</sup> / <sub>4</sub> "– 22"	17 <sup>1</sup> / <sub>2</sub> "	19 <sup>11</sup> / <sub>16</sub> "– 21 <sup>11</sup> / <sub>16</sub> "	1°
<b>Stools</b>										
	27 <sup>3</sup> / <sub>4</sub> "	27 <sup>3</sup> / <sub>4</sub> "	46 <sup>7</sup> / <sub>8</sub> "– 51 <sup>5</sup> / <sub>8</sub> "	17 <sup>1</sup> / <sub>4</sub> "	N.A.	18 <sup>1</sup> / <sub>2</sub> "	21 <sup>3</sup> / <sub>4</sub> "– 31 <sup>1</sup> / <sub>2</sub> "	17 <sup>1</sup> / <sub>2</sub> "	21"	2 <sup>1</sup> / <sub>2</sub> °

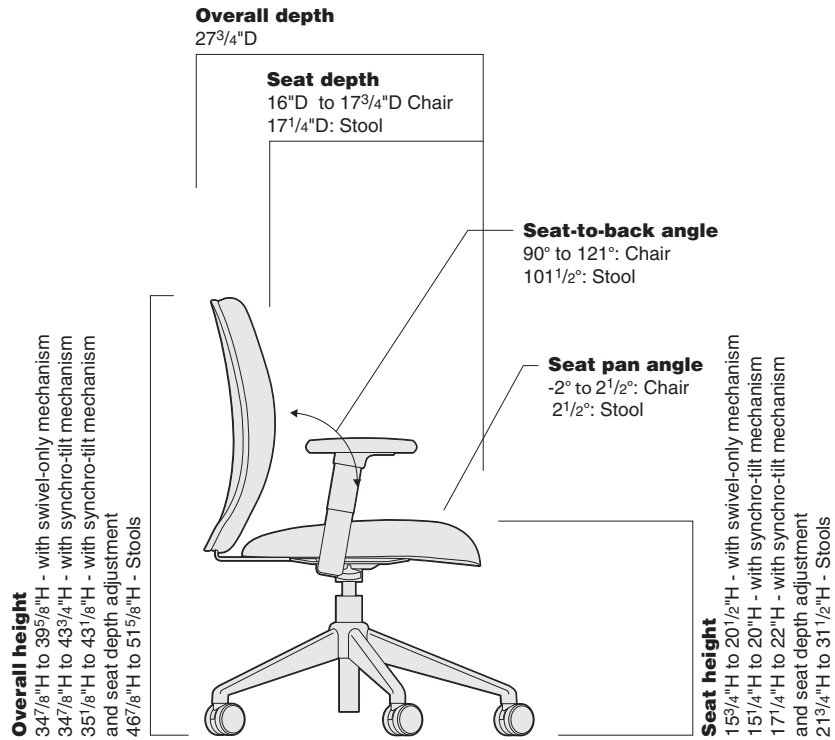
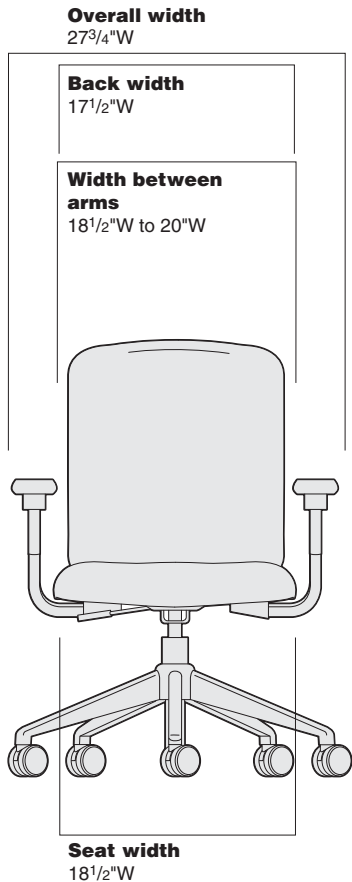

• Angle Between Seat and Back	• Width Between Arms	• Arm Cap Width	• Arm Cap Length	• Arm Height from Seat (Fixed Arms)	• Arm Height from Seat (Adjustable Arms)	• Foot Ring Diameter	• Foot Ring Height
101 <sup>1</sup> / <sub>2</sub> °	18 <sup>1</sup> / <sub>2</sub> "–20"	3 <sup>1</sup> / <sub>2</sub> "	6 <sup>1</sup> / <sub>2</sub> "	9"	7"–11"	N.A.	N.A.
101 <sup>1</sup> / <sub>2</sub> °	18 <sup>1</sup> / <sub>2</sub> "–20"	3 <sup>1</sup> / <sub>2</sub> "	6 <sup>1</sup> / <sub>2</sub> "	9"	7"–11"	N.A.	N.A.
90°–121°	18 <sup>1</sup> / <sub>2</sub> "–20"	3 <sup>1</sup> / <sub>2</sub> "	6 <sup>1</sup> / <sub>2</sub> "	9"	7"–11"	N.A.	N.A.
94°–111°	18 <sup>1</sup> / <sub>2</sub> "–20"	3 <sup>1</sup> / <sub>2</sub> "	6 <sup>1</sup> / <sub>2</sub> "	9"	7"–11"	N.A.	N.A.
101 <sup>1</sup> / <sub>2</sub> °	18 <sup>1</sup> / <sub>2</sub> "–20"	3 <sup>1</sup> / <sub>2</sub> "	6 <sup>1</sup> / <sub>2</sub> "	9"	7"–11"	20"	7 <sup>3</sup> / <sub>4</sub> "–13 <sup>1</sup> / <sub>4</sub> "

# Jack Task Chairs

With Swivel-Only Mechanism

*Tip: Hard dual-wheel casters are for use on carpet. Use on hard surfaces, including floor mats, will affect chair stability and may result in personal injury.*

Standard Includes		Required to Specify
<ul style="list-style-type: none"> <li>▶ Need help? Product details, page 174</li> </ul>	<ul style="list-style-type: none"> <li>• Swivel-only mechanism</li> <li>• Pneumatic seat height</li> <li>• Stool: includes taller pneumatic height and black foot ring, if selected</li> <li>• Arms: height-adjustable T-arms or fixed T-arms, if arms are specified: black plastic</li> <li>• Upholstered seat and inner back: fabric price group 1</li> <li>• Outer back: black plastic</li> <li>• Five arm base: reinforced black plastic</li> <li>• Hard dual-wheel casters: black</li> <li>• Shipped ready to assemble</li> <li>• Meets Cal. 117 requirements</li> </ul>	<ul style="list-style-type: none"> <li>1 Style number</li> <li>2 Fabric color number for upholstery</li> <li>3 Options, if selected (see below)</li> <li>▶ See <i>Surface Materials</i>, page 305.</li> </ul>

Options	U.S. Price	Required to Specify
<b>Surface Materials</b> <ul style="list-style-type: none"> <li>• Fabric price group 1</li> <li>• Fabric price group 2</li> <li>• Fabric price group 3</li> <li>• Fabric price group 4</li> <li>• Fabric price group 5</li> <li>• Fabric price group 6</li> <li>• Fabric price group 7</li> <li>• Fabric price group 8</li> <li>• Fabric price group 9</li> <li>• Fabric price group 10</li> <li>• Customer's Own Material (COM)</li> </ul>	<ul style="list-style-type: none"> <li>No cost</li> <li>+\$ 25</li> <li>+\$ 47</li> <li>+\$ 66</li> <li>+\$ 83</li> <li>+\$103</li> <li>+\$118</li> <li>+\$149</li> <li>+\$183</li> <li>+\$208</li> <li>+\$ 36</li> </ul>	<ul style="list-style-type: none"> <li>Specify fabric color number.</li> <li>Specify fabric color number.</li> <li>Specify fabric color number.</li> <li>Specify fabric color number.</li> <li>Specify fabric color number.</li> <li>Specify fabric color number.</li> <li>Specify fabric color number.</li> <li>Specify fabric color number.</li> <li>Specify fabric color number.</li> <li>Specify fabric color number.</li> <li>▶ See <i>Understanding Customer's Own Material (COM)</i>, page 324.</li> </ul>
<b>Casters</b> <ul style="list-style-type: none"> <li>• Soft dual-wheel casters for use on hard floors</li> </ul>	<ul style="list-style-type: none"> <li>+\$ 30</li> </ul>	<ul style="list-style-type: none"> <li>Specify <i>with soft casters</i>.</li> </ul>
<b>Glides</b> <ul style="list-style-type: none"> <li>• Non-marring plastic glides</li> </ul>	<ul style="list-style-type: none"> <li>+\$ 30</li> </ul>	<ul style="list-style-type: none"> <li>Specify <i>with glides</i>.</li> </ul>

*Tip: The a la carte square-back guest chair, TS30107, complements the Jack task chairs.*

▶ Detailed dimensions, page 176

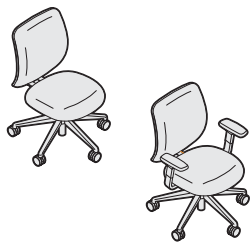

Specification Information	
<ul style="list-style-type: none"> <li>• <b>Style Number</b></li> <li>• <b>U.S. Base Price</b></li> </ul>	

## Full-Back Task Chair

### Armless

**TS30301** \$325

### With Fixed-Height and Maintenance-Width T-arms

**TS30311** \$405

### With Height-Adjustable and Maintenance-Width T-arms

**TS30321** \$450

## Full-Back Task Stool

### Armless

**TS30302** \$452

### With Fixed-Height and Maintenance-Width T-arms

**TS30312** \$537

### With Height-Adjustable and Maintenance-Width T-arms

**TS30322** \$576

# Jack Task Chairs

## With Swivel-Tilt Mechanism

*Tip: Hard dual-wheel casters are for use on carpet. Use on hard surfaces, including floor mats, will affect chair stability and may result in personal injury.*

Standard Includes		Required to Specify
<ul style="list-style-type: none"> <li>▶ Need help? Product details, page 174</li> </ul>	<ul style="list-style-type: none"> <li>• Swivel-tilt mechanism</li> <li>• Pneumatic seat height</li> <li>• Upright back lock</li> <li>• Arms: height-adjustable T-arms or fixed T-arms, if arms are specified: black plastic</li> <li>• Upholstered seat and inner back: fabric price group 1</li> <li>• Outer back: black plastic</li> <li>• Five arm base: reinforced black plastic</li> <li>• Hard dual-wheel casters: black</li> <li>• Shipped ready to assemble</li> <li>• Meets Cal. 117 requirements</li> </ul>	<ul style="list-style-type: none"> <li>1 Style number</li> <li>2 Fabric color number for upholstery</li> <li>3 Options, if selected (see below)</li> <li>▶ See <i>Surface Materials</i>, page 305.</li> </ul>

	Options	U.S. Price	Required to Specify
<b>Surface Materials</b>	<b>Upholstery</b> <ul style="list-style-type: none"> <li>• Fabric price group 1</li> <li>• Fabric price group 2</li> <li>• Fabric price group 3</li> <li>• Fabric price group 4</li> <li>• Fabric price group 5</li> <li>• Fabric price group 6</li> <li>• Fabric price group 7</li> <li>• Fabric price group 8</li> <li>• Fabric price group 9</li> <li>• Fabric price group 10</li> <li>• Customer's Own Material (COM)</li> </ul>	<ul style="list-style-type: none"> <li>No cost</li> <li>+\$ 25</li> <li>+\$ 47</li> <li>+\$ 66</li> <li>+\$ 83</li> <li>+\$103</li> <li>+\$118</li> <li>+\$149</li> <li>+\$183</li> <li>+\$208</li> <li>+\$ 36</li> </ul>	<ul style="list-style-type: none"> <li>Specify fabric color number.</li> <li>Specify fabric color number.</li> <li>Specify fabric color number.</li> <li>Specify fabric color number.</li> <li>Specify fabric color number.</li> <li>Specify fabric color number.</li> <li>Specify fabric color number.</li> <li>Specify fabric color number.</li> <li>Specify fabric color number.</li> <li>Specify fabric color number.</li> <li>▶ See <i>Understanding Customer's Own Material (COM)</i>, page 324.</li> </ul>
<b>Casters</b>	<ul style="list-style-type: none"> <li>• Soft dual-wheel casters for use on hard floors</li> </ul>	<ul style="list-style-type: none"> <li>+\$ 30</li> </ul>	<ul style="list-style-type: none"> <li>Specify <i>with soft casters</i>.</li> </ul>
<b>Glides</b>	<ul style="list-style-type: none"> <li>• Non-marring plastic glides</li> </ul>	<ul style="list-style-type: none"> <li>+\$ 30</li> </ul>	<ul style="list-style-type: none"> <li>Specify <i>with glides</i>.</li> </ul>

*Tip: The a la carte square-back guest chair, TS30107, complements the Jack task chairs.*

▶ Detailed dimensions, page 176

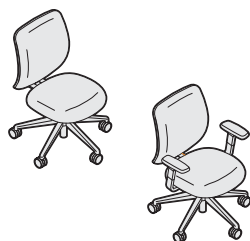

Specification Information	
• <b>Style Number</b>	• <b>U.S. Base Price</b>
.....	.....

Full-Back Task Chair with Swivel-Tilt	
<b>Armless</b>	
<b>TS30305</b>	\$359
<b>With Fixed-Height and Maintenance-Width T-arms</b>	
<b>TS30315</b>	\$444
<b>With Height-Adjustable and Maintenance-Width T-arms</b>	
<b>TS30325</b>	\$485

Jack

 **For Canadian Pricing**  
 Multiply U.S. Price by the Canadian price factor.  
 ▶ See page 1 for details.

# Jack Task Chairs

With Synchro-Tilt Mechanism

*Tip: Hard dual-wheel casters are for use on carpet. Use on hard surfaces, including floor mats, will affect chair stability and may result in personal injury.*

Standard Includes	Required to Specify
<ul style="list-style-type: none"> <li>Need help? Product details, page 174</li> <li>Synchro-tilt mechanism</li> <li>Pneumatic seat height</li> <li>Tilt tension</li> <li>Variable back lock</li> <li>Adjustable back height</li> <li>Arms: height-adjustable T-arms or fixed T-arms, if arms are specified: black plastic</li> <li>Upholstered seat and inner back: Fabric price group 1</li> <li>Outer back: black plastic</li> <li>Five arm base: reinforced black plastic</li> <li>Hard dual-wheel casters: black</li> <li>Shipped ready to assemble</li> <li>Meets Cal. 117 requirements</li> </ul>	<ul style="list-style-type: none"> <li>1 Style number</li> <li>2 Fabric color number for upholstery</li> <li>3 Options, if selected (see below)</li> <li>▶ See <i>Surface Materials</i>, page 305.</li> </ul>

Options	U.S. Price	Required to Specify
<b>Surface Materials</b> <ul style="list-style-type: none"> <li>Fabric price group 1</li> <li>Fabric price group 2</li> <li>Fabric price group 3</li> <li>Fabric price group 4</li> <li>Fabric price group 5</li> <li>Fabric price group 6</li> <li>Fabric price group 7</li> <li>Fabric price group 8</li> <li>Fabric price group 9</li> <li>Fabric price group 10</li> <li>Customer's Own Material (COM)</li> </ul>	<ul style="list-style-type: none"> <li>No cost</li> <li>+\$ 25</li> <li>+\$ 47</li> <li>+\$ 66</li> <li>+\$ 83</li> <li>+\$103</li> <li>+\$118</li> <li>+\$149</li> <li>+\$183</li> <li>+\$208</li> <li>+\$ 36</li> </ul>	<ul style="list-style-type: none"> <li>Specify fabric color number.</li> <li>Specify fabric color number.</li> <li>Specify fabric color number.</li> <li>Specify fabric color number.</li> <li>Specify fabric color number.</li> <li>Specify fabric color number.</li> <li>Specify fabric color number.</li> <li>Specify fabric color number.</li> <li>Specify fabric color number.</li> <li>Specify fabric color number.</li> <li>▶ See <i>Understanding Customer's Own Material (COM)</i>, page 324.</li> </ul>
<b>Casters</b> <ul style="list-style-type: none"> <li>Soft dual-wheel casters for use on hard floors</li> </ul>	<ul style="list-style-type: none"> <li>+\$ 30</li> </ul>	<ul style="list-style-type: none"> <li>Specify <i>with soft casters</i>.</li> </ul>
<b>Glides</b> <ul style="list-style-type: none"> <li>Non-marring plastic glides</li> </ul>	<ul style="list-style-type: none"> <li>+\$ 30</li> </ul>	<ul style="list-style-type: none"> <li>Specify <i>with glides</i>.</li> </ul>

*Tip: The a la carte square-back guest chair, TS30107, complements the Jack task chairs.*

▶ Detailed dimensions, page 176

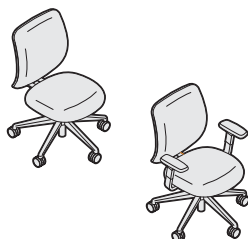
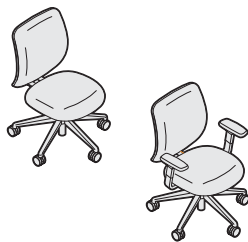

Specification Information	
• Style Number	• U.S. Base Price
.....	.....

## Full-Back Task Chair with Synchro-tilt

Armless	
<b>TS30303</b>	\$464
With Fixed-Height and Maintenance-Width T-arms	
<b>TS30313</b>	\$546
With Height-Adjustable and Maintenance-Width T-arms	
<b>TS30323</b>	\$585
.....	.....

## Full-Back Task Chair with Synchro-tilt and Seat Depth

Armless	
<b>TS30304</b>	\$558
With Fixed-Height and Maintenance-Width T-arms	
<b>TS30314</b>	\$635
With Height-Adjustable and Maintenance-Width T-arms	
<b>TS30324</b>	\$687
.....	.....

---

# Understanding and Specifying Buoy

## Multipurpose Seating

---

### Product Details

Buoy	182
Dimensions	183

---

### Specifying

Buoy	184
------	-----

# Buoy

**Buoy** is collaborative seating for teams that helps people move freely, change postures, and stay energized and comfortable.  
► Specifying, page 184

**Buoy** is 18" in diameter.

**Buoy** comes in six different colors, is lightweight at 20 lb and ships in a carton fully assembled.

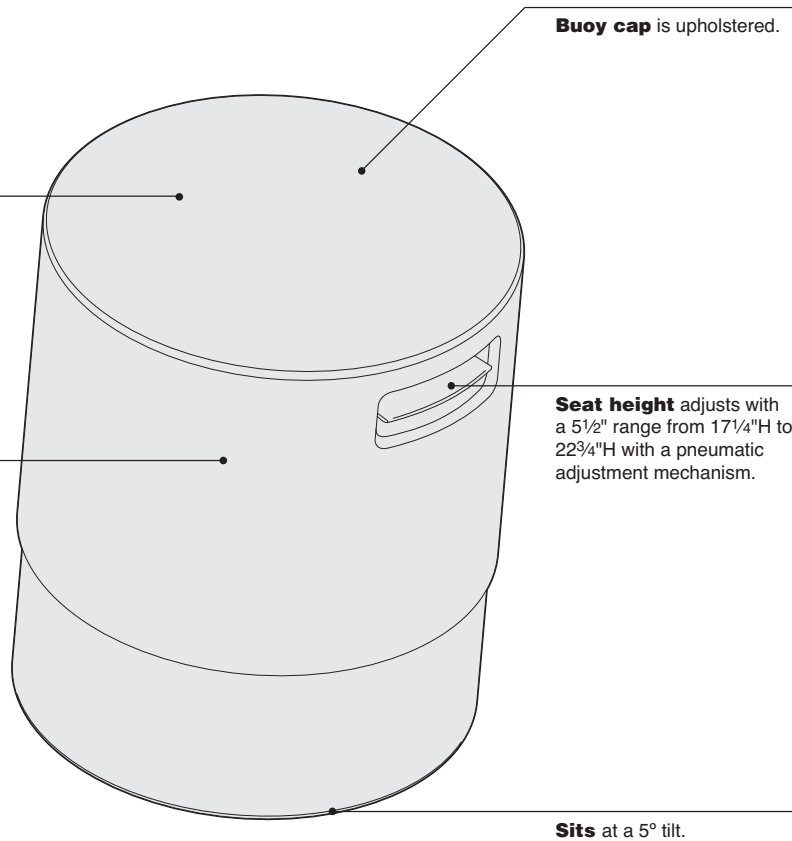

**Buoy cap** is upholstered.

**Seat height** adjusts with a 5 1/2" range from 17 1/4"H to 22 3/4"H with a pneumatic adjustment mechanism.

**Sits** at a 5° tilt.

## Product Details

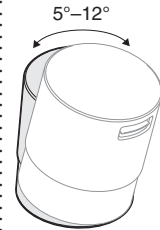

**Tilts** up to 12° to encourage active sitting.

## Adjustment Features

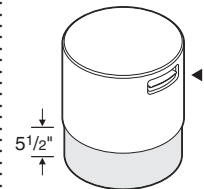

**Seat height** adjusts pneumatically. To lower, hold handle up while seated. To raise, hold handle up and keep weight off. Range of adjustability is 5 1/2".

## Surface Materials

► See surface materials on page 247 for specific availability or refer to the *Surface Materials Reference Manual* for further information.

## Dimensions

► Page 183

# Dimensions

Buoy

• Features	• Overall Depth	Width	Height
<b>Buoy</b>			
<b>Multipurpose Seating</b>			
Buoy	18"	18"	17¼"–22¾"

# Buoy

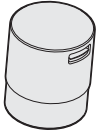

Tip: For body plastic color number based on style number, see page 248.

Tip: Not recommended for use on hard floors. May cause scratches.

Standard Includes		Required to Specify
<ul style="list-style-type: none"> <li>▶ Need help? Product details, page 182</li> </ul>	<ul style="list-style-type: none"> <li>• Body: plastic based on style number</li> <li>• Base: 6527 Merle</li> <li>• Cap: fabric</li> <li>• Pneumatic height adjustment</li> <li>• Ships fully assembled</li> </ul>	<ul style="list-style-type: none"> <li>1 Style number</li> <li>2 Fabric color number for cap</li> <li>3 Options, if selected (see below)</li> <li>▶ See <i>Surface Materials</i>, page 247.</li> </ul>

Options	U.S. Price	Required to Specify
<b>Surface Materials</b> <ul style="list-style-type: none"> <li>• <b>Cap</b></li> <li>• Fabric price group 1</li> <li>• Fabric price group 2</li> <li>• Fabric price group 4</li> <li>• Fabric price group 5</li> <li>• Fabric price group 6</li> <li>• COM</li> <li>• Non-upholstered cap: 6527 Merle only</li> </ul>	<ul style="list-style-type: none"> <li>No cost</li> <li>+\$27</li> <li>+\$54</li> <li>+\$63</li> <li>+\$72</li> <li>+\$35</li> <li>+\$27</li> </ul>	<ul style="list-style-type: none"> <li>Specify fabric color number.</li> <li>Specify fabric color number.</li> <li>Specify fabric color number.</li> <li>Specify fabric color number.</li> <li>Specify fabric color number.</li> <li>Specify fabric color number.</li> <li>Specify fabric color number.</li> <li>Specify with non-upholstered cap.</li> </ul>

Specification Information				
• Dimensions			• Style Number	• U.S. Base Price
D	W	H		
18"	18"	17¼"-22¾"	<b>TSBUOYBLACK</b>	\$346
18"	18"	17¼"-22¾"	<b>TSBUOYWHITE</b>	\$346
18"	18"	17¼"-22¾"	<b>TSBUOYGREY</b>	\$346
18"	18"	17¼"-22¾"	<b>TSBUOYBLUE</b>	\$346
18"	18"	17¼"-22¾"	<b>TSBUOYGREEN</b>	\$346
18"	18"	17¼"-22¾"	<b>TSBUOYRED</b>	\$346



**For Canadian Pricing**  
 Multiply U.S. Price by the Canadian price factor.  
 ▶ See page 1 for details.

---

# Understanding and Specifying Shortcut

## Multipurpose Seating

### Product Details

Shortcut	186
Dimensions	188

### Specifying

Shortcut	190
----------	-----

# Shortcut

**Shortcut** is a collaborative seating application that encourages people to move freely, change postures, and stay energized, yet comfortable.

► Specifying, page 190

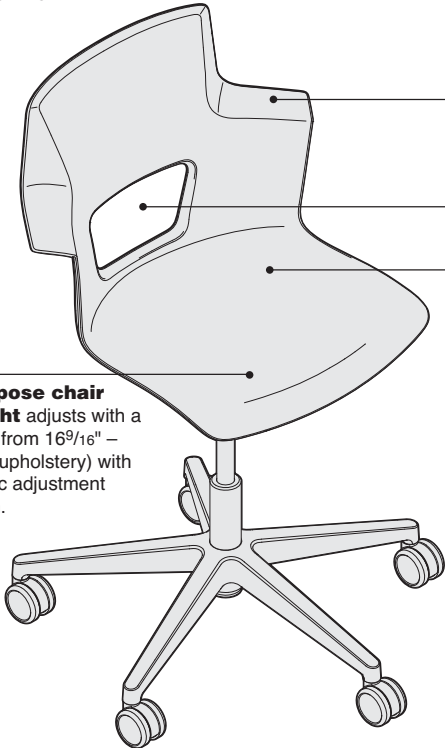

**Multi-purpose chair seat height** adjusts with a  $4\frac{5}{8}$ " range from  $16\frac{9}{16}$ " –  $21\frac{3}{16}$ " (no upholstery) with a pneumatic adjustment mechanism.

**Multi-purpose stool seat height** adjusts with a  $10\frac{3}{16}$ " range from  $22\frac{1}{8}$ " –  $32\frac{5}{16}$ " (no upholstery) with a pneumatic adjustment mechanism.

**Five star base** is standard.

**Hard, dual wheeled casters** are standard for use on carpets. Soft, merle centered, roll-control, dual-wheel casters are available for use on hard floors or chair mats.

**Abbreviated arms** allow users to pull up to a worksurface with ease.

**Cut-out** provides more flexibility.

**The seat of both the stool and chair** are made up of polypropylene plastic.

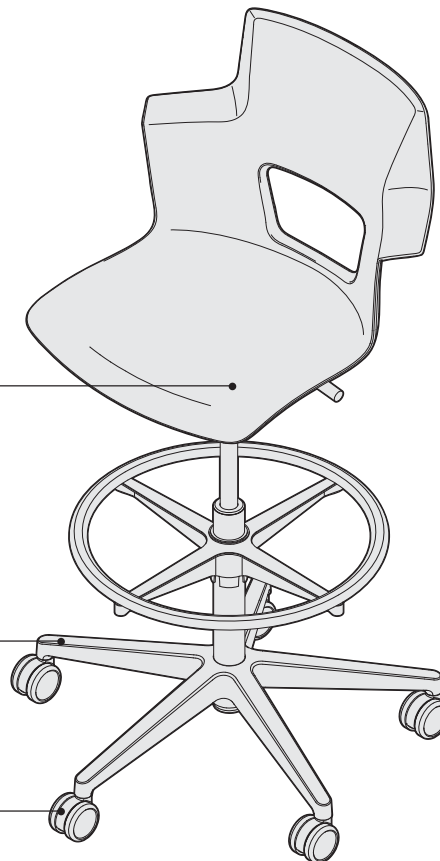

## Adjustment Features

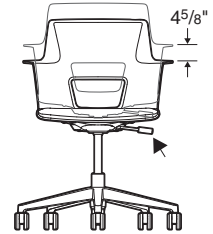

**Seat height** adjusts with a  $4\frac{5}{8}$ " range from  $16\frac{9}{16}$ " –  $21\frac{3}{16}$ " (no upholstery) with a pneumatic adjustment mechanism.

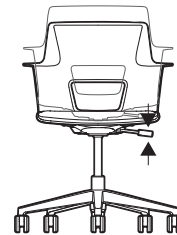

**Seat height adjusts** pneumatically. To lower, pull lever up while seated. To raise, pull lever up and keep weight off of the chair. Lever is located on the left hand side.

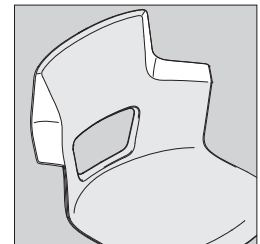

**Elbow rests** are abbreviated to stay out of the way as the user gets closer to the worksurface and supports a wide range of postures.



**Cushion option** is available for extra support and comfort.

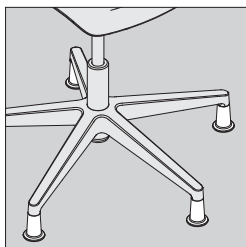

**Glides** are available as an option. Glides ship assembled on the chair or stool and maintain the same height as casters.

**Soft roll-control caster option** features an internal brake that activates when the chair is not under load to reduce shifting when user stands up.

### Surface Materials

▶ See surface materials on page 247 for specific availability or refer to the *Surface Materials Reference Manual* for further information.

### Upholstery

- Fabric
- Leather
- Elmosoft
- COM (Customer's Own Material)
- COL (Customer's Own Leather)

### Hard components

Chair (shell, five star base)

### Shell

6009	Arctic White
6059	Sterling Dark Solid
6205	Black
6333	Picasso
6335	Wasabi
6337	Element
6338	Chili

### Base

4140	Arctic White
4799	Platinum Metallic
6205	Black

### Hard casters

6205	Black
6249	Platinum Solid

*Tip: Casters paint color defaults to coordinate with base color.*

### Soft casters with 6527

Merle center

6205	Black
6249	Platinum Solid

*Tip: Casters paint color defaults to coordinate with base color.*

### Cylinder

4799	Platinum Metallic
6205	Black

*Tip: Cylinder paint color defaults to coordinate with base color.*

### All Steelcase seating with standard upholstery fabrics

complies with requirements of the State of California Technical Bulletin 117. All standard seating is labeled to be in compliance with California 117.

### Programs & Services

**Local codes** may have special requirements for upholstery.

### Dimensions

▶ Page 188

# Dimensions

## Shortcut

• Features	• Overall Depth	Width	• Seat Height	• Seat Depth	• Seat Width	• Seat Height from Floor	• Back Width	• Back Height from Seat
------------	-----------------	-------	---------------	--------------	--------------	--------------------------	--------------	-------------------------

### Shortcut

#### Multipurpose Seating

Chair	24½"	24¼"	31½"–35½"	16¾"	19⅝"	16⅞"–21⅜"	21"	18¼"
Stool	24½"	24¼"	36½"–47"	16¾"	19⅝"	22⅛"–32⅝"	21"	18¼"

• Back • Lumbar • Height	• Seat • Pan • Angle	• Angle • Between • Seat and • Back	• Width • Between • Elbow • Rest
--------------------------------	----------------------------	--	---

9 <sup>5</sup> / <sub>16</sub> "	8.2"	within 0–4°	21"
9 <sup>1</sup> / <sub>4</sub> "	8.5"	within 0–4°	21"

# Shortcut

## Chair



*Tip: Hard dual-wheel casters are for use on carpet. Use on hard surfaces, including floor mats, will affect chair stability and may result in personal injury.*

*Tip: Upholstery is only applicable if seat cushion is a selected option.*

*Tip: Base color will determine the cylinder and caster color. White or platinum base will receive platinum cylinder and platinum casters; a black base will receive black cylinder and black casters.*

*Tip: Craft in upholstery cautions the use of stripes and patterns on Shortcut. Please use fabric database when specifying.*

*Tip: Casters default to coordinate with base color.*

Standard Includes		Required to Specify
<ul style="list-style-type: none"> <li>▶ Need help? Product details, page 186</li> </ul>	<ul style="list-style-type: none"> <li>• Seat shell: plastic</li> <li>• Five star base: 6205 Black plastic</li> <li>• Pneumatic seat height</li> <li>• Hard dual-wheel casters: 6205 Black</li> <li>• Shipped ready to assemble</li> <li>• Meets Cal. 117 requirements</li> </ul>	<ol style="list-style-type: none"> <li>1 Style number</li> <li>2 Color number for base</li> <li>3 Plastic color number for shell</li> <li>4 Options, if selected (see below)</li> </ol> <ul style="list-style-type: none"> <li>▶ See <i>Surface Materials</i>, page 247.</li> </ul>

Options	U.S. Price	Required to Specify
<b>Seat Cushion</b>	• Cushion +\$140	Specify <i>with cushion</i> and specify fabric color number.
<b>Surface Materials</b>	<p><b>Upholstery</b></p> <ul style="list-style-type: none"> <li>• Fabric price group 1 No cost</li> <li>• Fabric price group 2 +\$ 10</li> <li>• Fabric price group 3 +\$ 25</li> <li>• Fabric price group 4 +\$ 34</li> <li>• Fabric price group 5 +\$ 41</li> <li>• Fabric price group 6 +\$ 50</li> <li>• Fabric price group 7 +\$ 60</li> <li>• Fabric price group 8 +\$ 75</li> <li>• Fabric price group 9 +\$ 92</li> <li>• Fabric price group 10 +\$106</li> <li>• Leather +\$ 89</li> <li>• Elmosoft +\$104</li> <li>• Customer's Own Material (COM) +\$ 36</li> </ul> <p>• Customer's Own Leather (COL) +\$ 36</p> <p><b>Base</b></p> <ul style="list-style-type: none"> <li>• Arctic White Gloss +\$ 37</li> <li>• Platinum Metallic +\$ 37</li> </ul>	<p>Specify fabric color number.</p> <p>Specify fabric color number.</p> <p>Specify fabric color number.</p> <p>Specify fabric color number.</p> <p>Specify fabric color number.</p> <p>Specify fabric color number.</p> <p>Specify fabric color number.</p> <p>Specify fabric color number.</p> <p>Specify fabric color number.</p> <p>Specify fabric color number.</p> <p>Specify fabric color number.</p> <p>Specify leather color number.</p> <p>Specify elmosoft color number.</p> <ul style="list-style-type: none"> <li>▶ See <i>Understanding Customer's Own Material (COM)</i>, page 324.</li> <li>▶ See <i>Understanding Customer's Own Material (COM)</i>, page 324.</li> </ul> <p>Specify <i>with 4140 Arctic White Gloss</i>.</p> <p>Specify <i>with 4799 Platinum Metallic</i>.</p>
<b>Casters</b>	<ul style="list-style-type: none"> <li>• Hard casters No cost</li> <li>• Soft dual-wheel casters +\$ 30 for use on hard floors</li> </ul>	<p>Specify <i>with hard casters</i>.</p> <p>Specify <i>with soft casters</i>.</p>
<b>Glides</b>	• Non-marring plastic glides +\$ 30	Specify <i>with glides</i> .

Specification Information	
• Style Number	• U.S. Base Price
TS31201A	\$422

▶ Detailed dimensions, page 188



**For Canadian Pricing**  
 Multiply U.S. Price by the Canadian price factor.  
 ▶ See page 1 for details.

# Shortcut

## Stool



*Tip: Hard dual-wheel casters are for use on carpet. Use on hard surfaces, including floor mats, will affect chair stability and may result in personal injury.*

*Tip: Upholstery is only applicable if seat cushion is a selected option.*

*Tip: Base color will determine the cylinder and caster color. White or platinum base will receive platinum cylinder and platinum casters; a black base will receive black cylinder and black casters.*

*Tip: Craft in upholstery cautions the use of stripes and patterns on Shortcut. Please use fabric database when specifying.*

*Tip: Casters default to coordinate with base color.*

Standard Includes	Required to Specify
<ul style="list-style-type: none"> <li>▶ Need help? Product details, page 186</li> <li>• Seat shell: plastic</li> <li>• Five star base: 6205 Black plastic</li> <li>• Pneumatic seat height</li> <li>• Hard dual-wheel casters: 6205 Black</li> <li>• Shipped ready to assemble</li> <li>• Meets Cal. 117 requirements</li> </ul>	<ul style="list-style-type: none"> <li>1 Style number</li> <li>2 Color number for base</li> <li>3 Plastic color number for shell</li> <li>4 Options, if selected (see below)</li> <li>▶ See <i>Surface Materials</i>, page 247.</li> </ul>

Options	U.S. Price	Required to Specify
<b>Seat Cushion</b>	• Cushion +\$140	Specify <i>with cushion</i> and specify fabric color number.
<b>Surface Materials</b>	<p><b>Upholstery</b></p> <ul style="list-style-type: none"> <li>• Fabric price group 1 No cost</li> <li>• Fabric price group 2 +\$ 10</li> <li>• Fabric price group 3 +\$ 25</li> <li>• Fabric price group 4 +\$ 34</li> <li>• Fabric price group 5 +\$ 41</li> <li>• Fabric price group 6 +\$ 50</li> <li>• Fabric price group 7 +\$ 60</li> <li>• Fabric price group 8 +\$ 75</li> <li>• Fabric price group 9 +\$ 92</li> <li>• Fabric price group 10 +\$106</li> <li>• Leather +\$ 89</li> <li>• Elmosoft +\$104</li> <li>• Customer's Own Material (COM) +\$ 36</li> </ul> <p>• Customer's Own Leather (COL) +\$ 36</p> <p><b>Base</b></p> <ul style="list-style-type: none"> <li>• Arctic White Gloss +\$ 37</li> <li>• Platinum Metallic +\$ 37</li> </ul>	<ul style="list-style-type: none"> <li>Specify fabric color number.</li> <li>Specify fabric color number.</li> <li>Specify fabric color number.</li> <li>Specify fabric color number.</li> <li>Specify fabric color number.</li> <li>Specify fabric color number.</li> <li>Specify fabric color number.</li> <li>Specify fabric color number.</li> <li>Specify fabric color number.</li> <li>Specify fabric color number.</li> <li>Specify leather color number.</li> <li>Specify elmosoft color number.</li> <li>▶ See <i>Understanding Customer's Own Material (COM)</i>, page 324.</li> <li>▶ See <i>Understanding Customer's Own Material (COM)</i>, page 324</li> </ul> <p>Specify <i>with 4140 Arctic White Gloss</i>. Specify <i>with 4799 Platinum Metallic</i>.</p>
<b>Casters</b>	<ul style="list-style-type: none"> <li>• Hard casters No cost</li> <li>• Soft dual-wheel casters for use on hard floors +\$ 30</li> </ul>	Specify <i>with hard casters</i> . Specify <i>with soft casters</i> .
<b>Glides</b>	• Non-marring plastic glides +\$ 30	Specify <i>with glides</i> .

Specification Information	
Style Number	U.S. Base Price
<b>TS31202B</b>	\$605

▶ Detailed dimensions, page 188

**For Canadian Pricing**  
Multiply U.S. Price by the Canadian price factor.  
▶ See page 1 for details.

# Shortcut

## Cushion



Standard Includes	Required to Specify
<ul style="list-style-type: none"> <li>▶ Need help? Product details, page 186</li> <li>• Cushion: fabric</li> <li>• Shipped ready to assemble</li> <li>• Meets Cal. 117 requirements</li> </ul>	<ul style="list-style-type: none"> <li>1 Style number</li> <li>2 Fabric color number for cushion</li> <li>3 Options, if selected (see below)</li> <li>▶ See <i>Surface Materials</i>, page 247.</li> </ul>

Surface Materials	Options	U.S. Price	Required to Specify
	<b>Upholstery</b>		
	• Fabric price group 1	No cost	Specify fabric color number.
	• Fabric price group 2	+\$ 10	Specify fabric color number.
	• Fabric price group 3	+\$ 25	Specify fabric color number.
	• Fabric price group 4	+\$ 34	Specify fabric color number.
	• Fabric price group 5	+\$ 41	Specify fabric color number.
	• Fabric price group 6	+\$ 50	Specify fabric color number.
	• Fabric price group 7	+\$ 60	Specify fabric color number.
	• Fabric price group 8	+\$ 75	Specify fabric color number.
	• Fabric price group 9	+\$ 92	Specify fabric color number.
	• Fabric price group 10	+\$106	Specify fabric color number.
	• Leather	+\$ 89	Specify leather color number.
	• Elmosoft	+\$104	Specify elmosoft color number.
	• Customer's Own Material (COM)	+\$ 36	▶ See <i>Understanding Customer's Own Material (COM)</i> , page 324.
	• Customer's Own Leather (COL)	+\$ 36	▶ See <i>Understanding Customer's Own Material (COM)</i> , page 324.

Specification Information	
Style Number	U.S. Base Price
TS31203	\$140

▶ Detailed dimensions, page 188



**For Canadian Pricing**

Multiply U.S. Price by the Canadian price factor.

▶ See page 1 for details.

---

# Understanding and Specifying cobi Select Multipurpose Seating



## Product Details

cobi Select	194
Dimensions	196



## Specifying

cobi Select	198
-------------	-----

# cobi Select

**cobi** is collaborative seating for teams that helps people move freely, change postures, and stay energized and comfortable.

► Specifying, page 198

**Flexible top edge** allows for multiple postures while maintaining support and comfort.

**Flexing fingers in back** offer support while moving and conforming to the user.

**Weight-activated mechanism** provides support by automatically responding to the users movements.

**Five-arm base** is standard.

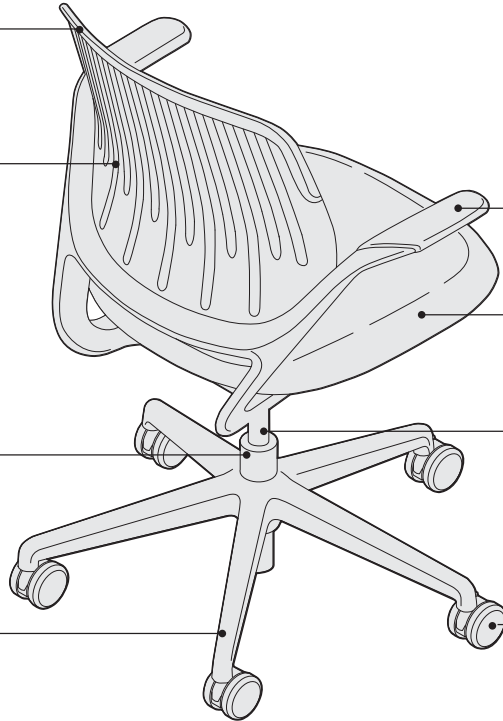

**Arms** are constructed of a soft durable rubber compound.

**Flexible seat edge on all 3-sides** supports multiple postures while relieving thigh pressure.

**Seat height** adjusts with a 5" range from 15½"H to 20½"H with a pneumatic adjustment mechanism.

**Hard, dual-wheel casters** are standard for use on carpets. Soft, roll-control, dual-wheel casters are available for use on hard floors or chair mats.

## Product Details

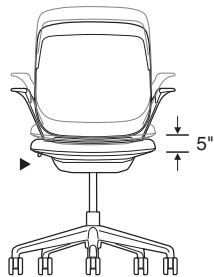

**Weight-activated mechanism** provides individual support without a tension control by intuitively sensing and supporting the users center of gravity.

**Adjustment Features****Seat Adjustments****Seat height adjusts**

pneumatically. To lower, pull lever up while seated. To raise, pull lever up and keep your weight off the chair.

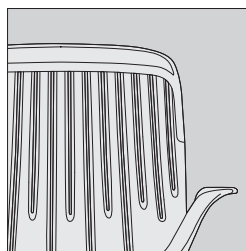
**Flexing fingers in back**

promote movement and provide support for a wide range of postures.

**Soft roll-control caster option**

features an internal brake that activates when the chair is not under load to reduce shifting when user stands up.

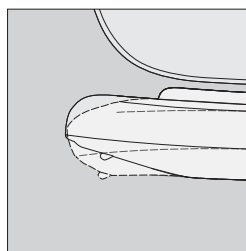

**Flexing seat edge on all 3-sides** supports multiple postures while relieving high pressure.

**Surface Materials**

▶ See surface materials on page 247 for specific availability or refer to the *Surface Materials Reference Manual* for further information.

**Back Upholstery**

- Connect 3D (back only)

**Seat Upholstery**

- Cogent: Connect (seat only)

**Outer Back**

- 6295 Near Black

**Arm Caps, Top Edge, and Casters**

- 6205 Black

**All Steelcase seating with standard upholstery fabrics** complies with requirements of the State of California Technical Bulletin 117. All standard seating is labeled to be in compliance with California 117.

**Programs & Services**

▶ See the *Surface Materials Reference Manual* for further detail about programs and services offered for seating.

Soil-retardant treatment is available on all other seating fabrics at an additional upcharge per seating unit. To order this option, please select "Soil-Retardant Treatment" under "Optional Accessories."

For soil-retardant treatment on COMs, please select "Soil-Retardant Treatment" under "Optional Accessories." Minimums or additional yardage may be required. Please contact the vendor directly for specific information.

Extended lead times may be necessary for this service.

Contact your Steelcase Solutions Fulfillment Team Representative at 1.888.STEELCASE (1.888.783.3522) or send an e-mail to [lineone@steelcase.com](mailto:lineone@steelcase.com).

**Local codes** may have special requirements for upholstery.

**Dimensions**

▶ Page 196

**Resources****Printed Materials**

▶ cobi Brochure (09-0000049)

# Dimensions

cobi Select

Features	Overall Depth	Width	Height	Seat Depth	Functional Seat Depth	Seat Width	Seat Height from Floor	Back Width	Back Height from Seat
<b>cobi Select</b>									
<b>Multipurpose Seating</b>									
	23 <sup>1</sup> / <sub>4</sub> "	24 <sup>3</sup> / <sub>4</sub> "	34"-39"	19 <sup>1</sup> / <sub>2</sub> "	17 <sup>7</sup> / <sub>8</sub> "	18 <sup>3</sup> / <sub>4</sub> "	15 <sup>1</sup> / <sub>2</sub> "-20 <sup>1</sup> / <sub>2</sub> "	18"	19 <sup>1</sup> / <sub>2</sub> "

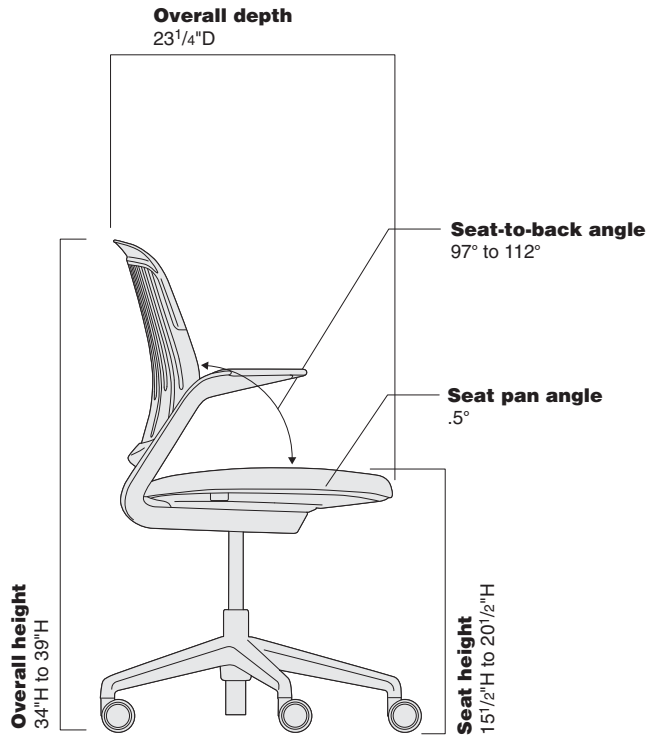
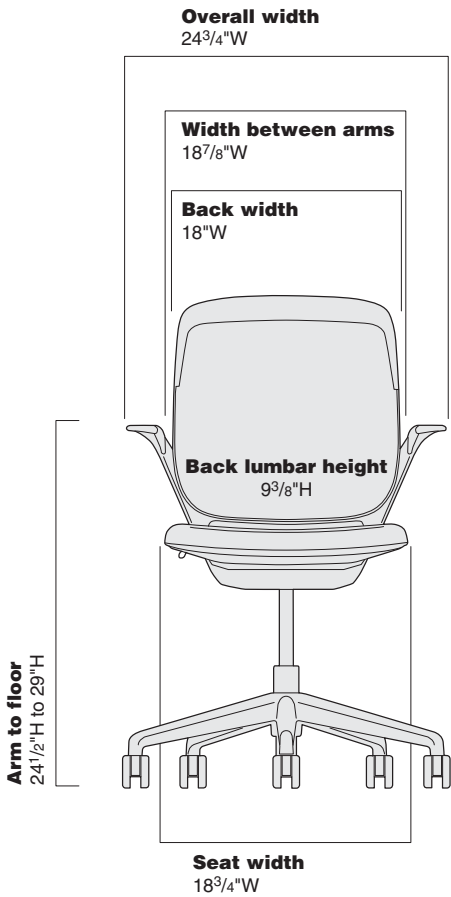

• Back • Lumbar • Height	• Width • Between • Arms	• Arm • to • Floor	• Arm • Height • from • Seat	• Seat • Pan • Angle	• Angle • Between • Seat and • Back
--------------------------------	--------------------------------	--------------------------	---------------------------------------	----------------------------	--

9 <sup>3</sup> / <sub>8</sub> "	18 <sup>7</sup> / <sub>8</sub> "	24 <sup>1</sup> / <sub>4</sub> "–29"	8 <sup>7</sup> / <sub>8</sub> "	.5°	97°–112°
---------------------------------	----------------------------------	--------------------------------------	---------------------------------	-----	----------

# cobi Select



Standard Includes		Required to Specify
<ul style="list-style-type: none"> <li>▶ Need help? Product details, page 194</li> </ul>	<ul style="list-style-type: none"> <li>• Weight-activated mechanism</li> <li>• 5" pneumatic seat-height adjustment</li> <li>• Fixed arms: plastic to match outer back</li> <li>• Back upholstery: Connect 3D</li> <li>• Seat upholstery: Cogent: Connect matches seat upholstery</li> <li>• Frame, outer back, and five-arm base: Near Black</li> <li>• 2½"-diameter, hard composition, dual-wheel casters: black plastic</li> </ul>	<ul style="list-style-type: none"> <li>1 Style number</li> <li>2 Connect 3D color number for back</li> <li>3 Options, if selected (see below)</li> <li>▶ See <i>Surface Materials</i>, page 247.</li> </ul>

*Tip: Arm caps, top edge, and casters default to coordinate and match outer back color.*

Options	U.S. Price	Required to Specify
<b>Surface Materials</b> <ul style="list-style-type: none"> <li>• Fabric price group 2</li> <li>• Soil-retardant treatment applied to upholstery fabric</li> </ul>	No cost +\$30	Specify fabric color number. Specify <i>with soil-retardant treatment</i> .
<b>Casters</b> <ul style="list-style-type: none"> <li>• Soft, dual-wheel roll-control casters</li> </ul>	+\$30	Specify <i>with soft roll-control casters</i> .
<b>Glides</b> <ul style="list-style-type: none"> <li>• Glides: plastic</li> </ul>	+\$30	Specify <i>with glides</i> .

Specification Information	
Style Number	U.S. Base Price
TS434EXP	\$926

▶ Detailed dimensions, page 196



**For Canadian Pricing**  
 Multiply U.S. Price by the Canadian price factor.  
 ▶ See page 1 for details.

---

# Understanding and Specifying Uno Select

## Multipurpose Seating



### Product Details

Uno Select	200
Dimensions	202



### Specifying

Uno Select	203
------------	-----

# Uno Select

**Uno Select** is collaborative seating for teams that helps people move freely, change postures, and stay energized and comfortable.

► Specifying, page 203

**Arm caps** are constructed of a soft durable rubber compound.

**Hammock suspension** allows the chair to rock gently with your body movement.

**Five-arm base** is standard.

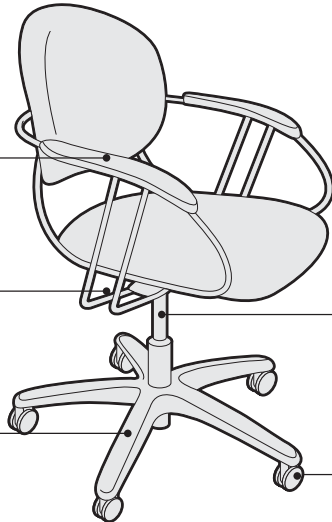

**Seat height** adjusts with a 5" range from 15½"H to 20½"H with a pneumatic adjustment mechanism.

**Hard, dual-wheel casters** are standard for use on carpets. Soft, roll-control, dual-wheel casters are available for use on hard floors or chair mats.

## Product Details



**Swivel seat** allows 360° of rotation.

## Adjustment Features

### Seat Adjustments

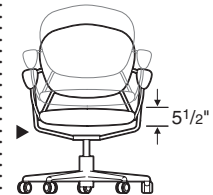

**Seat height** adjusts pneumatically. To lower, pull lever up while seated. To raise, pull lever up and keep your weight off the chair.

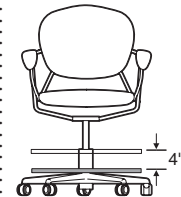

**Foot ring height on stools** adjusts by rotating it counterclockwise to unlock. Then raise or lower ring up to 5½" to desired position before rotating it clockwise to lock. The foot ring has a diameter of 20".

### Surface Materials

▶ See surface materials on page 247 for specific availability or refer to the *Surface Materials Reference Manual* for further information.

#### Back and seat upholstery

- Cogent: Connect
- Buzz2

#### Glides

- Plastic

#### Foot ring on stools

- 6205 Black

**All Steelcase seating with standard upholstery fabrics** complies with requirements of the State of California Technical Bulletin 117. All standard seating is labeled to be in compliance with California 117.

### Programs & Services

▶ See the *Surface Materials Reference Manual* for further detail about programs and services offered for seating.

Soil-retardant treatment is available on all other seating fabrics at an additional upcharge per seating unit. To order this option, please select "Soil-Retardant Treatment" under "Optional Accessories."

For soil-retardant treatment on COMs, please select "Soil-Retardant Treatment" under "Optional Accessories." Minimums or additional yardage may be required. Please contact the vendor directly for specific information.

Extended lead times may be necessary for this service.

Contact your Steelcase Solutions Fulfillment Team Representative at 1.888.STEELCASE (1.888.783.3522) or send an e-mail to [lineone@steelcase.com](mailto:lineone@steelcase.com).

**Local codes** may have special requirements for upholstery.

### Dimensions

▶ Page 202

### Resources

#### Printed Materials

▶ Uno Brochure (09-0000049)

# Dimensions

Uno Select

Features	Overall Depth	Width	Height	Functional Seat Depth	Seat Width	Seat Height from Floor	Back Width	Back Height from Seat	Width Between Arms	Arm to Floor	Arm Height from Seat
----------	---------------	-------	--------	-----------------------	------------	------------------------	------------	-----------------------	--------------------	--------------	----------------------

## Uno Select

### Multipurpose Seating

23"	25"	31½"–36½"	19"	18¼"	15½"–20½"	17½"	18"	18½"	23"–28"	7½"
-----	-----	-----------	-----	------	-----------	------	-----	------	---------	-----

### Stool Option

23¼"	24¾"	37½"–45"	19"	18¼"	23½"–33¾"	17½"	18"	18½"	31"–41¼"	7½"
------	------	----------	-----	------	-----------	------	-----	------	----------	-----

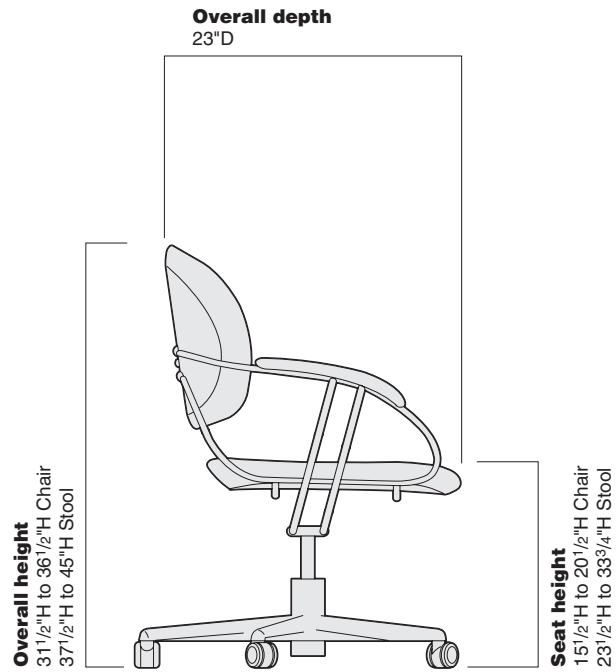
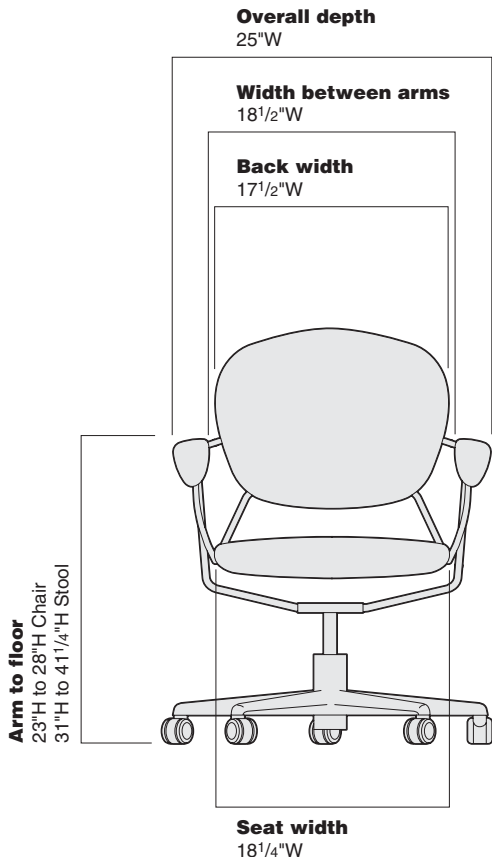

# Uno Select



Tip: Frame is available in black only.

Tip: Hard dual-wheel casters are for use on carpet. Use on hard surfaces, including floor mats, will affect chair stability and may result in personal injury.

Standard Includes		Required to Specify
<ul style="list-style-type: none"> <li>▶ Need help? Product details, page 200</li> </ul>	<ul style="list-style-type: none"> <li>• Hammock-style support</li> <li>• Swivel mechanism</li> <li>• Pneumatic height adjustment</li> <li>• Upholstered seat and back: fabric price group 2</li> <li>• Outer back: black plastic</li> <li>• Five-arm base: reinforced black plastic</li> <li>• Hard dual-wheel casters: black</li> <li>• Stool ring, if selected: black paint</li> <li>• Shipped ready to assemble with no tools required</li> <li>• Meets Cal. 117 requirements</li> </ul>	<ul style="list-style-type: none"> <li>1 Style number</li> <li>2 Fabric color number for upholstery</li> <li>3 Options, if selected (see below)</li> <li>▶ See <i>Surface Materials</i>, page 247.</li> </ul>

Options	U.S. Price	Required to Specify
<b>Surface Materials</b> <ul style="list-style-type: none"> <li>• Upholstery fabric</li> <li>• Fabric price group 2</li> </ul>	No cost	Specify fabric color number.
<b>Stool Kit</b> <ul style="list-style-type: none"> <li>• Stool kit with swivel mechanism</li> </ul>	+\$192	Specify <i>with stool kit</i> .
<b>Casters</b> <ul style="list-style-type: none"> <li>• Soft dual-wheel casters for use on hard floors</li> </ul>	No cost	Specify <i>with soft casters</i> .
<b>Glides</b> <ul style="list-style-type: none"> <li>• Non-marring plastic glides</li> </ul>	+\$ 30	Specify <i>with glides</i> .

### Specification Information

Style Number	U.S. Base Price

### Mid-Back Multi-Purpose Chair

<b>TS311EXP</b>	\$536

▶ Detailed dimensions, page 202



**For Canadian Pricing**  
 Multiply U.S. Price by the Canadian price factor.  
 ▶ See page 1 for details.



---

# Understanding and Specifying Scoop

## Multipurpose Seating

---

### Product Details

Scoop	206
Dimensions	207

---

### Specifying

Scoop	208
-------	-----

# Scoop

**Scoop** is collaborative seating for teams that helps people move freely, change postures, and stay energized and comfortable.

► Specifying, page 208

**Durable wire frame** is lightweight and available in several finishes.

**Glides** are standard for use on carpets. Soft glides are available for use on hard floors or chair mats.

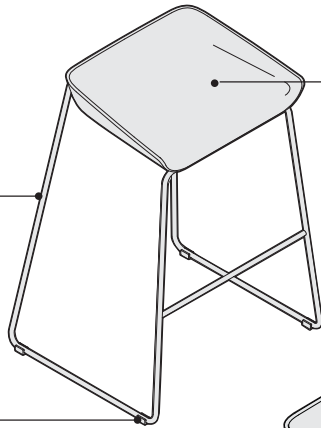

**Seat** is constructed of molded plastic and available in white or cobblestone.

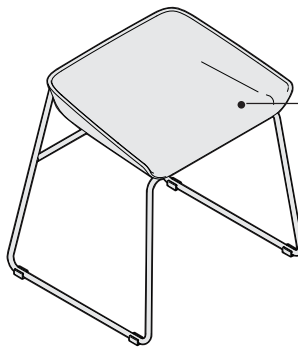

**Upholstered seat** is also available.

## Product Details

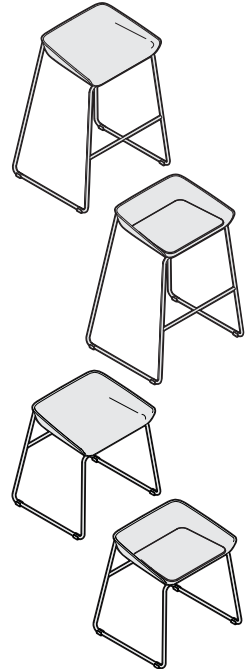

**Chairs and stools** are available with or without upholstered seat.

## Surface Materials

► See surface materials on page 247 for specific availability or refer to the *Surface Materials Reference Manual* for further information.

## Dimensions

► Page 207

# Dimensions

## Scoop

Features	Overall Depth	Width	Height	Functional Seat Depth	Seat Width	Seat Height from Floor	Foot Bar Height
<b>Scoop</b>							
<b>Side Chairs</b>							
	18 <sup>7</sup> / <sub>8</sub> "	21 <sup>1</sup> / <sub>8</sub> "	22 <sup>1</sup> / <sub>2</sub> "	13 <sup>1</sup> / <sub>2</sub> "	17"	18 <sup>3</sup> / <sub>8</sub> "	N.A.
<b>Stools</b>							
	22"	23"	33"	13 <sup>1</sup> / <sub>2</sub> "	17"	28 <sup>3</sup> / <sub>4</sub> "	12 <sup>3</sup> / <sub>4</sub> "

Scoop

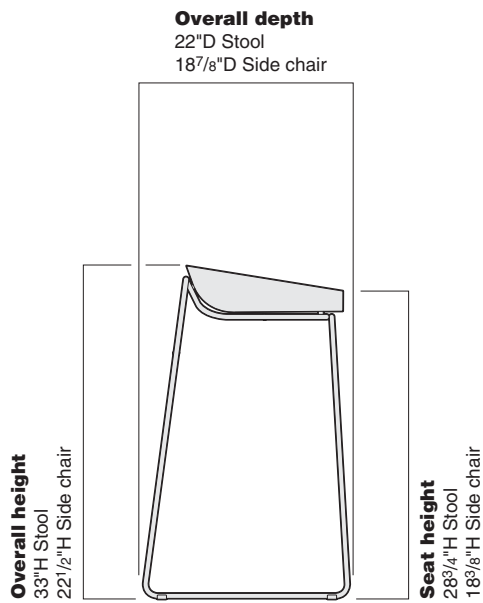
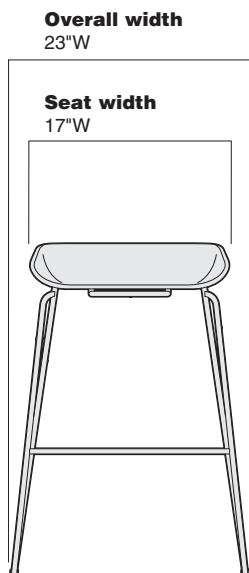

# Scoop

## Stools

	Standard Includes	Required to Specify
▶ Need help? Product details, page 206	<ul style="list-style-type: none"> <li>• Steel wire frame: paint price group 1</li> <li>• Seat: plastic</li> <li>• Upholstered seat, if selected: fabric price group 1</li> <li>• Glides</li> <li>• Shipped fully assembled</li> </ul>	<ol style="list-style-type: none"> <li>1 Style number</li> <li>2 Paint color number for frame</li> <li>3 Plastic color number for seat: 6618 White 6682 Cobblestone</li> <li>4 Fabric color number for upholstery, if selected</li> <li>5 Options, if selected (see below)</li> </ol> <p>▶ See <i>Surface Materials</i>, page 247.</p>

	Options	U.S. Price	Required to Specify
<b>Surface Materials</b>	<b>Steel wire frame</b>		
	<ul style="list-style-type: none"> <li>• Paint price group 1</li> <li>• Paint price group 2</li> </ul>	No cost +\$ 23	Specify paint color number. Specify paint color number.
	<b>Upholstery</b>		
	<ul style="list-style-type: none"> <li>• Fabric price group 1</li> <li>• Fabric price group 2</li> <li>• Fabric price group 3</li> <li>• Fabric price group 4</li> <li>• Fabric price group 5</li> <li>• Fabric price group 6</li> <li>• Fabric price group 7</li> <li>• Fabric price group 8</li> <li>• Fabric price group 9</li> <li>• Fabric price group 10</li> <li>• Customer's Own Material (COM)</li> </ul>	No cost +\$ 10 +\$ 25 +\$ 34 +\$ 41 +\$ 50 +\$ 60 +\$ 75 +\$ 92 +\$106 +\$ 16	Specify fabric color number. Specify fabric color number. Specify fabric color number. Specify fabric color number. Specify fabric color number. Specify fabric color number. Specify fabric color number. Specify fabric color number. Specify fabric color number. Specify fabric color number. Specify fabric color number. ▶ See <i>Understanding Customer's Own Material (COM)</i> , page 324.
<b>Glides</b>	<ul style="list-style-type: none"> <li>• Soft glides</li> </ul>	No cost	Specify with soft glides.

Specification Information	
• Style Number	• U.S. Base Price

Stool	
<b>TS30701</b>	\$332

Stool with Upholstered Seat	
<b>TS30702</b>	\$399

▶ Detailed dimensions, page 207

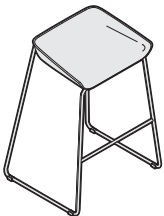

**For Canadian Pricing**  
Multiply U.S. Price by the Canadian price factor.  
▶ See page 1 for details.

## Side Chairs

	Standard Includes	Required to Specify
<p>► Need help? Product details, page 206</p>	<ul style="list-style-type: none"> <li>Steel wire frame: paint price group 1</li> <li>Seat: plastic</li> <li>Upholstered seat, if selected: fabric price group 1</li> <li>Glides</li> <li>Shipped fully assembled</li> </ul>	<ol style="list-style-type: none"> <li>Style number</li> <li>Paint color number for frame</li> <li>Plastic color number for seat: 6618 White, 6682 Cobblestone</li> <li>Fabric color number for upholstery, if selected</li> <li>Options, if selected (see below)</li> </ol> <p>► See <i>Surface Materials</i>, page 247.</p>

	Options	U.S. Price	Required to Specify
<b>Surface Materials</b>	<b>Steel wire frame</b>		
	<ul style="list-style-type: none"> <li>Paint price group 1</li> <li>Paint price group 2</li> </ul>	<p>No cost</p> <p>+\$ 23</p>	<p>Specify paint color number.</p> <p>Specify paint color number.</p>
	<b>Upholstery</b>		
	<ul style="list-style-type: none"> <li>Fabric price group 1</li> <li>Fabric price group 2</li> <li>Fabric price group 3</li> <li>Fabric price group 4</li> <li>Fabric price group 5</li> <li>Fabric price group 6</li> <li>Fabric price group 7</li> <li>Fabric price group 8</li> <li>Fabric price group 9</li> <li>Fabric price group 10</li> <li>Customer's Own Material (COM)</li> </ul>	<p>No cost</p> <p>+\$ 10</p> <p>+\$ 25</p> <p>+\$ 34</p> <p>+\$ 41</p> <p>+\$ 50</p> <p>+\$ 60</p> <p>+\$ 75</p> <p>+\$ 92</p> <p>+\$106</p> <p>+\$ 16</p>	<p>Specify fabric color number.</p> <p>Specify fabric color number.</p> <p>Specify fabric color number.</p> <p>Specify fabric color number.</p> <p>Specify fabric color number.</p> <p>Specify fabric color number.</p> <p>Specify fabric color number.</p> <p>Specify fabric color number.</p> <p>Specify fabric color number.</p> <p>Specify fabric color number.</p> <p>► See <i>Understanding Customer's Own Material (COM)</i>, page 324.</p>
<b>Glides</b>	<ul style="list-style-type: none"> <li>Soft glides</li> </ul>	No cost	Specify with soft glides.

### Specification Information

Style Number	U.S. Base Price

### Side Chair

TS30703 \$327

### Side Chair with Upholstered Seat

TS30704 \$394

► Detailed dimensions, page 207

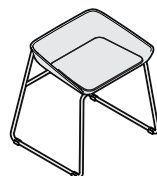
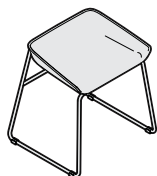

 **For Canadian Pricing**  
 Multiply U.S. Price by the Canadian price factor.  
 ► See page 1 for details.



---

# Understanding and Specifying Jenny Lounge Lounge Seating



## Product Details

Jenny Lounge	212
Dimensions	214



## Specifying

Jenny Lounge	216
--------------	-----

# Jenny Lounge

**Jenny lounge products**

are fully upholstered and have a relaxed appearance. They may show soft comfort wrinkles upon use.

► Specifying, page 216

**Supports** up to 225 pounds.

**Different fabrics** can be specified individually on the seat, inner back, outer back, and arms.

**Jenny tables** are available as a coffee table or end table.

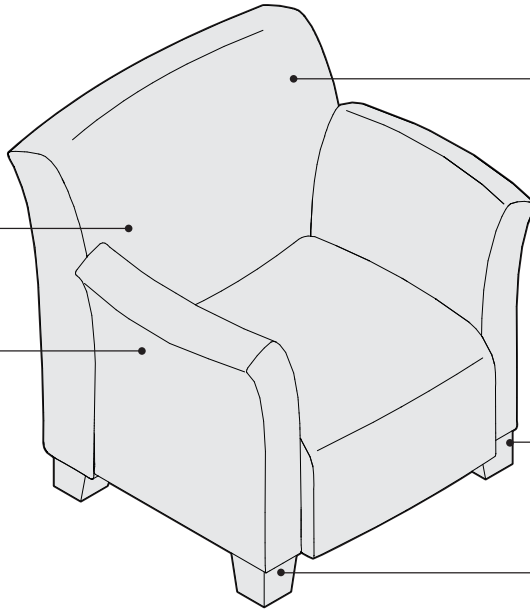

**Jenny** comes fully assembled.

**Legs** are standard in black except for Jenny Round which has standard brushed aluminum legs.

**Legs** have options of wood, brushed aluminum, and/or with casters.

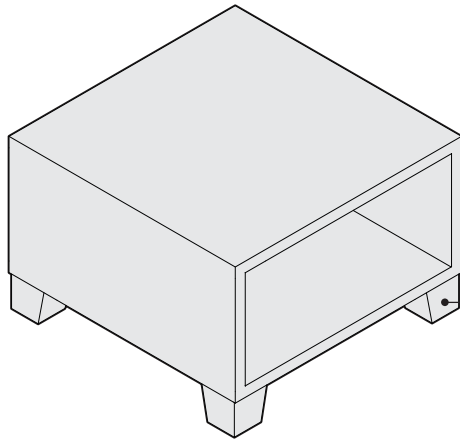

**Legs** are standard in black.

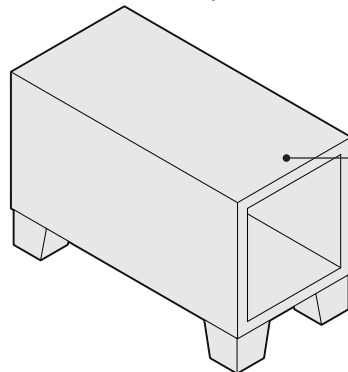

**Jenny tables** ship fully assembled.

## Product Details

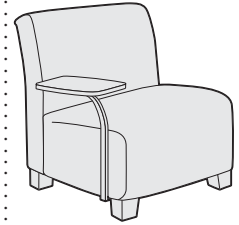

**Tablet arm** is only available on armless and one arm versions of Jenny.

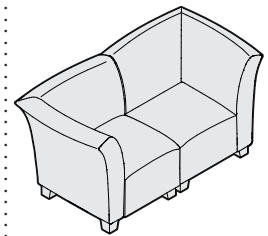

**Two Jenny pieces** shown as a love seat.

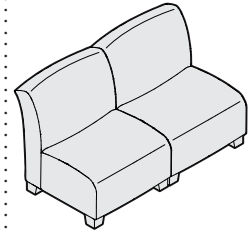

**Two armless Jenny pieces** shown as a bench.

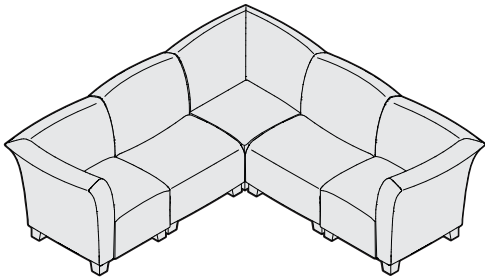

**Jenny seating shown** as a sectional.

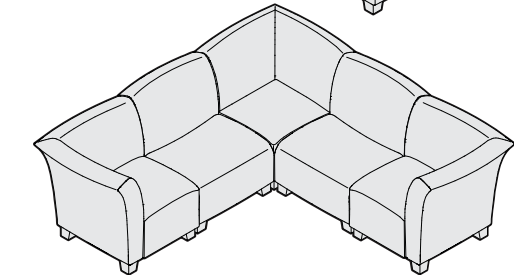
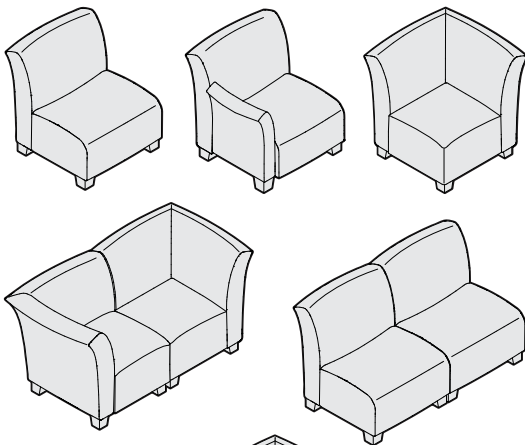

**Jenny seating** allows many different configurations using armless, left or right arms only, or corner version. Create a love seat, bench, or sectional using Jenny.

**Hard dual-wheel casters** are for use on carpet. Use on hard surfaces, including floor mats, will affect chair stability and may result in personal injury.

**Brushed aluminum legs** are adjustable and have 3/4" of height adjustment.

**Casters and tablet arm** are not retrofittable on style numbers TS31403 or TS31404.

**Surface Materials**

**Upholstery, hard components, casters (see Jack).**

There may be sheen or texture differences when using LPL and HPL in adjacent applications. Please use caution when mixing and matching different worksurface types.

Leather price group option ships at extended lead times.

**Jenny Corner**

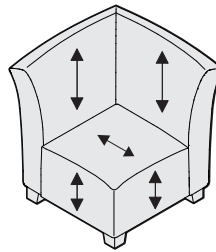

*Tip: Standard seat fabric directionality is applied as the diagram above indicates (e.g. TS31406).*

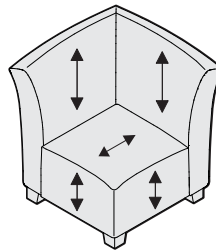

*Tip: Reverse seat fabric directionality is applied as the diagram above indicates (e.g. TS31426).*

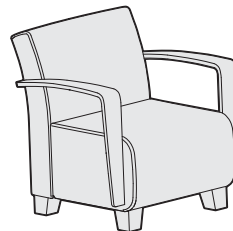

*Note: On Jenny with wood arms, due to natural variations in wood, finished products may vary in color, texture, and grain.*

**Dimensions**

▶ Page 214

# Dimensions

## Jenny Lounge

Features	Overall Depth	Width	Height	Functional Seat Depth	Seat Width	Seat Height from Floor	Back Width	Back Height from Seat	Width Between Arms
<b>Jenny Lounge</b>									
<b>Lounge Seating</b>									
Armless	32 <sup>1</sup> / <sub>2</sub> "	28 <sup>1</sup> / <sub>2</sub> "	32 <sup>1</sup> / <sub>4</sub> "	21"	28 <sup>1</sup> / <sub>2</sub> "	16", compressed	28 <sup>1</sup> / <sub>2</sub> "	18"	N.A.
Both Arms	32 <sup>1</sup> / <sub>2</sub> "	34 <sup>1</sup> / <sub>2</sub> "	32 <sup>1</sup> / <sub>4</sub> "	21"	19 <sup>3</sup> / <sub>4</sub> "	16", compressed	28 <sup>1</sup> / <sub>2</sub> "	18"	26"
Right arm or Left arm only	32 <sup>1</sup> / <sub>2</sub> "	31 <sup>1</sup> / <sub>2</sub> "	32 <sup>1</sup> / <sub>4</sub> "	21"	23 <sup>1</sup> / <sub>2</sub> "	16", compressed	28 <sup>1</sup> / <sub>2</sub> "	18"	N.A.
Corner	32"	32"	32"	20"	20"	N.A.	N.A.	18"	N.A.
Club	31 <sup>3</sup> / <sub>4</sub> "	31 <sup>3</sup> / <sub>4</sub> "	31 <sup>3</sup> / <sub>4</sub> "	21"	19"	16", compressed	28"	16"	19 <sup>1</sup> / <sub>2</sub> "
Round	31 <sup>3</sup> / <sub>4</sub> "	31 <sup>3</sup> / <sub>4</sub> "	31 <sup>3</sup> / <sub>4</sub> "	21"	19"	16", compressed	28 <sup>1</sup> / <sub>2</sub> "	18"	25 <sup>3</sup> / <sub>4</sub> "
Wood Arms	32 <sup>1</sup> / <sub>2</sub> "	32 <sup>1</sup> / <sub>2</sub> "	32 <sup>1</sup> / <sub>2</sub> "	21"	24"	16", compressed	24"	16"	24 <sup>1</sup> / <sub>4</sub> "
Ottoman	27 <sup>1</sup> / <sub>2</sub> "	28 <sup>1</sup> / <sub>2</sub> "	18"	N.A.	N.A.	N.A.	N.A.	N.A.	N.A.

• Arm Rest Width	• Arm Rest Length	• Arm Height to Floor	• Arm Height from Seat	• Tablet Width	• Tablet Length	• Tablet Height to Floor	• Tablet Height from Seat
N.A.	N.A.	N.A.	N.A.	9"	16"	24 <sup>1</sup> / <sub>2</sub> "	6 <sup>3</sup> / <sub>4</sub> "
4"	19 <sup>3</sup> / <sub>4</sub> "	26"	9 <sup>1</sup> / <sub>2</sub> "	N.A.	N.A.	N.A.	N.A.
4"	19 <sup>3</sup> / <sub>4</sub> "	26"	9 <sup>1</sup> / <sub>2</sub> "	9"	16"	24 <sup>1</sup> / <sub>2</sub> "	6 <sup>3</sup> / <sub>4</sub> "
N.A.	N.A.	N.A.	N.A.	N.A.	N.A.	N.A.	N.A.
4 <sup>1</sup> / <sub>2</sub> "	19 <sup>3</sup> / <sub>4</sub> "	26"	7 <sup>3</sup> / <sub>4</sub> "	N.A.	N.A.	N.A.	N.A.
4"	N.A.	26"	9 <sup>1</sup> / <sub>2</sub> "	N.A.	N.A.	N.A.	N.A.
3 <sup>1</sup> / <sub>2</sub> "	24"	26"	9"	N.A.	N.A.	N.A.	N.A.
N.A.	N.A.	N.A.	N.A.	N.A.	N.A.	N.A.	N.A.

# Jenny Lounge

## Armless

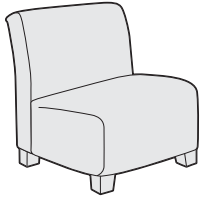

Tip: Jenny lounge chairs are available with multiple fabrics.

▶ See at right to specify.

Tip: When specifying multiple COM fabrics, indicate all surfaces where COM applies. Example: TS31401M with Designtex 1234 on seat, Designtex 5678 on inner back, and Designtex 9012 on outer back.

Tip: When specifying multiple fabrics and leather, specify suffix **M** before suffix **L**. Example: TS31401ML TS31401CML

Standard Includes	Required to Specify
<ul style="list-style-type: none"> <li>▶ Need help? Product details, page 212</li> <li>Fully upholstered lounge chair: fabric price group 1</li> <li>Tablet arm, if selected: Low-Pressure Laminate (LPL), or High-Pressure Laminate (HPL)</li> <li>3 mm edge band for tablet arm, if selected: plastic</li> <li>Hard dual-wheel casters or legs with glides: black plastic</li> <li>Shipped fully assembled</li> <li>Exception: Tablet arm is shipped ready to assemble.</li> <li>Meets Cal. 117 requirements</li> </ul>	<ol style="list-style-type: none"> <li>Style number</li> <li>Fabric color number for upholstery</li> <li>Low-Pressure Laminate or High-Pressure Laminate color number for tablet arm, if selected</li> <li>Plastic edge band color number for tablet arm, if selected</li> <li>Options, if selected (see below)</li> </ol> <p>▶ See <i>Surface Materials</i>, page 247.</p>

Surface Materials	Options	U.S. Price	Required to Specify
	<b>Single upholstery fabric</b> <ul style="list-style-type: none"> <li>Fabric price group 1</li> <li>Fabric price group 2</li> <li>Fabric price group 3</li> <li>Fabric price group 4</li> <li>Fabric price group 5</li> <li>Fabric price group 6</li> <li>Fabric price group 7</li> <li>Fabric price group 8</li> <li>Fabric price group 9</li> <li>Fabric price group 10</li> <li>Leather price group</li> </ul>	<ul style="list-style-type: none"> <li>No cost</li> <li>+\$ 30</li> <li>+\$ 67</li> <li>+\$ 95</li> <li>+\$ 122</li> <li>+\$ 152</li> <li>+\$ 180</li> <li>+\$ 228</li> <li>+\$ 285</li> <li>+\$ 323</li> <li>+\$1991</li> </ul>	<ul style="list-style-type: none"> <li>Specify fabric color number.</li> <li>Specify fabric color number.</li> <li>Specify fabric color number.</li> <li>Specify fabric color number.</li> <li>Specify fabric color number.</li> <li>Specify fabric color number.</li> <li>Specify fabric color number.</li> <li>Specify fabric color number.</li> <li>Specify fabric color number.</li> <li>Specify fabric color number.</li> <li>Specify fabric color number.</li> <li>Add suffix <b>L</b> to style number and specify leather color number.</li> </ul> <p>▶ See <i>Understanding Customer's Own Material (COM)</i>, page 324.</p> <p>Add suffix <b>L</b> to style number and specify leather color number.</p>
	<ul style="list-style-type: none"> <li>Customer's Own Material (COM)</li> <li>Customer's Own Leather (COL)</li> </ul>	<ul style="list-style-type: none"> <li>+\$ 36</li> <li>+\$ 36</li> </ul>	<p>▶ See <i>Understanding Customer's Own Material (COM)</i>, page 324.</p> <p>Add suffix <b>L</b> to style number and specify leather color number.</p>
	<b>Multiple upholstery fabrics</b> <ul style="list-style-type: none"> <li>Two or more fabrics on different chair components</li> </ul> <p>▶ See below and at right.</p>	<ul style="list-style-type: none"> <li>+\$ 63</li> </ul>	<p>Add suffix <b>M</b> to lounge chair style number and select fabric color number for:</p> <ol style="list-style-type: none"> <li>Seat</li> <li>Inner back</li> <li>Outer back</li> </ol> <p>Example: TS31401M with T015 on seat, T016 on inner back, and T017 on outer back.</p>
	<ol style="list-style-type: none"> <li><b>Fabric on seat</b> <ul style="list-style-type: none"> <li>Fabric price group 1</li> <li>Fabric price group 2</li> <li>Fabric price group 3</li> <li>Fabric price group 4</li> <li>Fabric price group 5</li> <li>Fabric price group 6</li> <li>Fabric price group 7</li> <li>Fabric price group 8</li> <li>Fabric price group 9</li> <li>Fabric price group 10</li> <li>Leather price group</li> </ul> </li> <li>Customer's Own Material (COM)</li> <li>Customer's Own Leather (COL)</li> </ol>	<ul style="list-style-type: none"> <li>No cost</li> <li>+\$ 11</li> <li>+\$ 32</li> <li>+\$ 42</li> <li>+\$ 56</li> <li>+\$ 69</li> <li>+\$ 82</li> <li>+\$ 105</li> <li>+\$ 128</li> <li>+\$ 147</li> <li>+\$ 969</li> <li>+\$ 16</li> <li>+\$ 16</li> </ul>	<ul style="list-style-type: none"> <li>Specify fabric color number.</li> <li>Specify fabric color number.</li> <li>Specify fabric color number.</li> <li>Specify fabric color number.</li> <li>Specify fabric color number.</li> <li>Specify fabric color number.</li> <li>Specify fabric color number.</li> <li>Specify fabric color number.</li> <li>Specify fabric color number.</li> <li>Specify fabric color number.</li> <li>Specify fabric color number.</li> <li>Add suffix <b>L</b> to style number and specify leather color number.</li> </ul> <p>▶ See <i>Understanding Customer's Own Material (COM)</i>, page 324.</p> <p>Add suffix <b>L</b> to style number and specify leather color number.</p>

▶ Options, continued on next page

▶ Detailed dimensions, page 214

► Options, continued from previous page

Options	U.S. Price	Required to Specify
<b>Surface Materials</b> (continued)		
<b>② Fabric on inner back</b>		
• Fabric price group 1	No cost	Specify fabric color number.
• Fabric price group 2	+\$ 8	Specify fabric color number.
• Fabric price group 3	+\$ 23	Specify fabric color number.
• Fabric price group 4	+\$ 31	Specify fabric color number.
• Fabric price group 5	+\$ 39	Specify fabric color number.
• Fabric price group 6	+\$ 47	Specify fabric color number.
• Fabric price group 7	+\$ 57	Specify fabric color number.
• Fabric price group 8	+\$ 71	Specify fabric color number.
• Fabric price group 9	+\$ 89	Specify fabric color number.
• Fabric price group 10	+\$103	Specify fabric color number.
• Leather price group	+\$445	Specify fabric color number. Add suffix <b>L</b> to style number and specify leather color number.
• Customer's Own Material (COM)	+\$ 16	► See <i>Understanding Customer's Own Material (COM)</i> , page 324.
• Customer's Own Leather (COL)	+\$ 16	Add suffix <b>L</b> to style number and specify leather color number.
<b>③ Fabric on outer back</b>		
• Fabric price group 1	No cost	Specify fabric color number.
• Fabric price group 2	+\$ 6	Specify fabric color number.
• Fabric price group 3	+\$ 14	Specify fabric color number.
• Fabric price group 4	+\$ 24	Specify fabric color number.
• Fabric price group 5	+\$ 30	Specify fabric color number.
• Fabric price group 6	+\$ 36	Specify fabric color number.
• Fabric price group 7	+\$ 42	Specify fabric color number.
• Fabric price group 8	+\$ 53	Specify fabric color number.
• Fabric price group 9	+\$ 67	Specify fabric color number.
• Fabric price group 10	+\$ 76	Specify fabric color number.
• Leather price group	+\$618	Specify fabric color number. Add suffix <b>L</b> to style number and specify leather color number.
• Customer's Own Material (COM)	+\$ 16	► See <i>Understanding Customer's Own Material (COM)</i> , page 324.
• Customer's Own Leather (COL)	+\$ 16	Add suffix <b>L</b> to style number and specify leather color number.
<b>Legs</b>		
• Brushed Aluminum legs	+\$113	Specify with <i>Brushed Aluminum legs</i> .
• Solid wood legs	+\$151	Specify with <i>solid wood legs</i> and select 3412 Natural Cherry, 3522 Clear Maple, or 3762 Dark Walnut.

**Related Products**

• Ganging kit

► Page 233

**Specification Information**

Style Number	U.S. Base Price	Style Number	U.S. Base Price	Style Number	U.S. Base Price	Style Number	U.S. Base Price
LPL	Price	HPL	Price	LPL	Price	HPL	Price

**With Glides**

**TS31401** \$1161

**With Two Casters and Two Glides**

**TS31401C** \$1209



Glides



Casters

**With Tablet Arm (180° Pivot)**

**TS31401T** \$1439      **TS31401H** \$1476

**With Tablet Arm (180° Pivot)**

**TS31401CT** \$1487      **TS31401CH** \$1524



Glides



Casters

Jenny Lounge, continued

With Arms

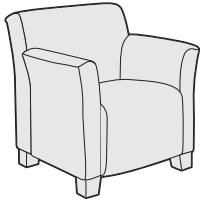

Tip: Jenny lounge chairs are available with multiple fabrics.

▶ See at right to specify.

Tip: When specifying multiple COM fabrics, indicate all surfaces where COM applies. Example: TS31402M with Designtex 1234 on seat, Designtex 5678 on inner back, Designtex 9012 on outer back, and Designtex 9012 on arms.

Tip: When specifying multiple fabrics and leather, specify suffix **M** before suffix **L**. Example: TS31401ML TS31401CML

Standard Includes	Required to Specify
<ul style="list-style-type: none"> <li>▶ Need help? Product details, page 212</li> <li>Fully upholstered lounge chair with arms: fabric price group 1</li> <li>Hard dual-wheel casters or legs with glides: black plastic</li> <li>Shipped fully assembled</li> <li>Meets Cal. 117 requirements</li> </ul>	<ul style="list-style-type: none"> <li>1 Style number</li> <li>2 Fabric color number for upholstery</li> <li>3 Options, if selected (see below)</li> <li>▶ See <i>Surface Materials</i>, page 247.</li> </ul>

Surface Materials	Options	U.S. Price	Required to Specify
	<b>Single upholstery fabric</b>		
	• Fabric price group 1	No cost	Specify fabric color number.
	• Fabric price group 2	+\$ 45	Specify fabric color number.
	• Fabric price group 3	+\$ 106	Specify fabric color number.
	• Fabric price group 4	+\$ 149	Specify fabric color number.
	• Fabric price group 5	+\$ 195	Specify fabric color number.
	• Fabric price group 6	+\$ 237	Specify fabric color number.
	• Fabric price group 7	+\$ 283	Specify fabric color number.
	• Fabric price group 8	+\$ 357	Specify fabric color number.
	• Fabric price group 9	+\$ 445	Specify fabric color number.
	• Fabric price group 10	+\$ 505	Specify fabric color number.
	• Leather price group	+\$3077	Specify fabric color number. Add suffix <b>L</b> to style number and specify leather color number.
	• Customer's Own Material (COM)	+\$ 36	▶ See <i>Understanding Customer's Own Material (COM)</i> , page 324.
	• Customer's Own Leather (COL)	+\$ 36	Add suffix <b>L</b> to style number and specify leather color number.

	<b>Multiple upholstery fabrics</b>		
	• Two or more fabrics on different chair components	+\$ 63	Add suffix <b>M</b> to lounge chair style number and select fabric color number for:
	▶ See below and at right.		<ol style="list-style-type: none"> <li>1 Seat</li> <li>2 Inner back</li> <li>3 Outer back</li> <li>4 Arms</li> </ol> <p>Example: TS31402M with T015 on seat, T016 on inner back, T017 on outer back, and T018 on arms.</p>
	<b>1 Fabric on seat</b>		
	• Fabric price group 1	No cost	Specify fabric color number.
	• Fabric price group 2	+\$ 11	Specify fabric color number.
	• Fabric price group 3	+\$ 32	Specify fabric color number.
	• Fabric price group 4	+\$ 42	Specify fabric color number.
	• Fabric price group 5	+\$ 56	Specify fabric color number.
	• Fabric price group 6	+\$ 69	Specify fabric color number.
	• Fabric price group 7	+\$ 82	Specify fabric color number.
	• Fabric price group 8	+\$ 105	Specify fabric color number.
	• Fabric price group 9	+\$ 128	Specify fabric color number.
	• Fabric price group 10	+\$ 147	Specify fabric color number.
	• Leather price group	+\$ 878	Specify fabric color number. Add suffix <b>L</b> to style number and specify leather color number.
	• Customer's Own Material (COM)	+\$ 16	▶ See <i>Understanding Customer's Own Material (COM)</i> , page 324.
	• Customer's Own Leather (COL)	+\$ 16	Add suffix <b>L</b> to style number and specify leather color number.

▶ Options, continued on next page

▶ Detailed dimensions, page 214



**For Canadian Pricing**

Multiply U.S. Price by the Canadian price factor.

▶ See page 1 for details.

► Options, continued from previous page

Options	U.S. Price	Required to Specify
<b>Surface Materials</b> (continued)		
<b>2 Fabric on inner back</b>		
• Fabric price group 1	No cost	Specify fabric color number.
• Fabric price group 2	+\$ 8	Specify fabric color number.
• Fabric price group 3	+\$ 23	Specify fabric color number.
• Fabric price group 4	+\$ 31	Specify fabric color number.
• Fabric price group 5	+\$ 39	Specify fabric color number.
• Fabric price group 6	+\$ 47	Specify fabric color number.
• Fabric price group 7	+\$ 57	Specify fabric color number.
• Fabric price group 8	+\$ 71	Specify fabric color number.
• Fabric price group 9	+\$ 89	Specify fabric color number.
• Fabric price group 10	+\$ 103	Specify fabric color number.
• Leather price group	+\$ 445	Specify fabric color number. Add suffix <b>L</b> to style number and specify leather color number.
• Customer's Own Material (COM)	+\$ 16	► See <i>Understanding Customer's Own Material (COM)</i> , page 324.
• Customer's Own Leather (COL)	+\$ 16	Add suffix <b>L</b> to style number and specify leather color number.
<b>3 Fabric on outer back</b>		
• Fabric price group 1	No cost	Specify fabric color number.
• Fabric price group 2	+\$ 6	Specify fabric color number.
• Fabric price group 3	+\$ 14	Specify fabric color number.
• Fabric price group 4	+\$ 24	Specify fabric color number.
• Fabric price group 5	+\$ 30	Specify fabric color number.
• Fabric price group 6	+\$ 36	Specify fabric color number.
• Fabric price group 7	+\$ 42	Specify fabric color number.
• Fabric price group 8	+\$ 53	Specify fabric color number.
• Fabric price group 9	+\$ 67	Specify fabric color number.
• Fabric price group 10	+\$ 76	Specify fabric color number.
• Leather price group	+\$ 618	Specify fabric color number. Add suffix <b>L</b> to style number and specify leather color number.
• Customer's Own Material (COM)	+\$ 16	► See <i>Understanding Customer's Own Material (COM)</i> , page 324.
• Customer's Own Leather (COL)	+\$ 16	Add suffix <b>L</b> to style number and specify leather color number.
<b>4 Fabric on arms</b>		
• Fabric price group 1	No cost	Specify fabric color number.
• Fabric price group 2	+\$ 15	Specify fabric color number.
• Fabric price group 3	+\$ 38	Specify fabric color number.
• Fabric price group 4	+\$ 53	Specify fabric color number.
• Fabric price group 5	+\$ 70	Specify fabric color number.
• Fabric price group 6	+\$ 85	Specify fabric color number.
• Fabric price group 7	+\$ 104	Specify fabric color number.
• Fabric price group 8	+\$ 127	Specify fabric color number.
• Fabric price group 9	+\$ 161	Specify fabric color number.
• Fabric price group 10	+\$ 181	Specify fabric color number.
• Leather price group	+\$1177	Specify fabric color number. Add suffix <b>L</b> to style number and specify leather color number.
• Customer's Own Material (COM)	+\$ 16	► See <i>Understanding Customer's Own Material (COM)</i> , page 324.
• Customer's Own Leather (COL)	+\$ 16	Add suffix <b>L</b> to style number and specify leather color number.
<b>Legs</b>		
• Brushed Aluminum legs	+\$ 113	Specify with <i>Brushed Aluminum legs</i> .
• Solid wood legs	+\$ 151	Specify with <i>solid wood legs</i> and select 3412 Natural Cherry, 3522 Clear Maple, or 3762 Dark Walnut.

Tip: Brushed Aluminum legs are adjustable and have 3/4" of height adjustment.

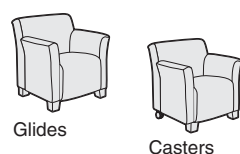

Glides

Casters

Specification Information

Style Number	U.S. Base Price	Style Number	U.S. Base Price
<b>With Glides</b>		<b>With Two Casters and Two Glides</b>	
TS31402	\$1301	TS31402C	\$1349

Jenny Lounge, continued

With Arm Left or Right

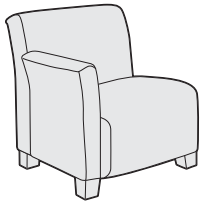

Tip: Jenny lounge chairs are available with multiple fabrics.

► See at right to specify.

Tip: When specifying multiple COM fabrics, indicate all surfaces where COM applies.

Example: TS31403M with Designtex 1234 on seat, Designtex 5678 on inner back, Designtex 9012 on outer back, and Designtex 9012 on arm.

Tip: When specifying multiple fabrics and leather, specify suffix M before suffix L.

Example: TS31401ML  
TS31401CML

► Detailed dimensions, page 214

Standard Includes	Required to Specify
<ul style="list-style-type: none"> <li>► Need help? Product details, page 212</li> <li>Fully upholstered lounge chair with arm left or right: fabric price group 1</li> <li>Tablet arm, if selected: Low-Pressure Laminate (LPL), or High-Pressure Laminate (HPL)</li> <li>3 mm edge band for tablet arm, if selected: plastic</li> <li>Hard dual-wheel casters or legs with glides: black plastic</li> <li>Shipped fully assembled</li> <li>Exception: Tablet arm is shipped ready to assemble.</li> <li>Meets Cal. 117 requirements</li> </ul>	<ol style="list-style-type: none"> <li>Style number</li> <li>Fabric color number for upholstery</li> <li>Low-Pressure Laminate or High-Pressure Laminate color number for tablet arm, if selected</li> <li>Plastic edge band color number for tablet arm, if selected</li> <li>Options, if selected (see below)</li> </ol> <p>► See <i>Surface Materials</i>, page 247.</p>

Surface Materials	Options	U.S. Price	Required to Specify
	<b>Single upholstery fabric</b>		
	<ul style="list-style-type: none"> <li>Fabric price group 1</li> <li>Fabric price group 2</li> <li>Fabric price group 3</li> <li>Fabric price group 4</li> <li>Fabric price group 5</li> <li>Fabric price group 6</li> <li>Fabric price group 7</li> <li>Fabric price group 8</li> <li>Fabric price group 9</li> <li>Fabric price group 10</li> <li>Leather price group</li> </ul>	<ul style="list-style-type: none"> <li>No cost</li> <li>+\$ 37</li> <li>+\$ 85</li> <li>+\$ 121</li> <li>+\$ 160</li> <li>+\$ 196</li> <li>+\$ 232</li> <li>+\$ 291</li> <li>+\$ 366</li> <li>+\$ 414</li> <li>+\$2561</li> </ul>	<ul style="list-style-type: none"> <li>Specify fabric color number.</li> <li>Specify fabric color number.</li> <li>Specify fabric color number.</li> <li>Specify fabric color number.</li> <li>Specify fabric color number.</li> <li>Specify fabric color number.</li> <li>Specify fabric color number.</li> <li>Specify fabric color number.</li> <li>Specify fabric color number.</li> <li>Specify fabric color number.</li> <li>Specify fabric color number.</li> <li>Add suffix <b>L</b> to style number and specify leather color number.</li> </ul>
	<ul style="list-style-type: none"> <li>Customer's Own Material (COM)</li> <li>Customer's Own Leather (COL)</li> </ul>	<ul style="list-style-type: none"> <li>+\$ 36</li> <li>+\$ 36</li> </ul>	<ul style="list-style-type: none"> <li>► See <i>Understanding Customer's Own Material (COM)</i>, page 324.</li> <li>Add suffix <b>L</b> to style number and specify leather color number.</li> </ul>
	<b>Multiple upholstery fabrics</b>		
	<ul style="list-style-type: none"> <li>Two or more fabrics on different chair components</li> </ul>	<ul style="list-style-type: none"> <li>+\$ 63</li> </ul>	<ul style="list-style-type: none"> <li>Add suffix <b>M</b> to lounge chair style number and select fabric color number for:</li> </ul>
	<ol style="list-style-type: none"> <li><b>Fabric on seat</b></li> </ol> <ul style="list-style-type: none"> <li>Fabric price group 1</li> <li>Fabric price group 2</li> <li>Fabric price group 3</li> <li>Fabric price group 4</li> <li>Fabric price group 5</li> <li>Fabric price group 6</li> <li>Fabric price group 7</li> <li>Fabric price group 8</li> <li>Fabric price group 9</li> <li>Fabric price group 10</li> <li>Leather price group</li> </ul>	<ul style="list-style-type: none"> <li>No cost</li> <li>+\$ 11</li> <li>+\$ 32</li> <li>+\$ 42</li> <li>+\$ 56</li> <li>+\$ 69</li> <li>+\$ 82</li> <li>+\$ 105</li> <li>+\$ 128</li> <li>+\$ 147</li> <li>+\$ 951</li> </ul>	<ol style="list-style-type: none"> <li>Seat</li> <li>Inner back</li> <li>Outer back</li> <li>Arm</li> </ol> <p>Example: TS31403M with T015 on seat, T016 on inner back, T017 on outer back, and T018 on arm.</p> <ul style="list-style-type: none"> <li>Specify fabric color number.</li> <li>Specify fabric color number.</li> <li>Specify fabric color number.</li> <li>Specify fabric color number.</li> <li>Specify fabric color number.</li> <li>Specify fabric color number.</li> <li>Specify fabric color number.</li> <li>Specify fabric color number.</li> <li>Specify fabric color number.</li> <li>Specify fabric color number.</li> <li>Specify fabric color number.</li> <li>Add suffix <b>L</b> to style number and specify leather color number.</li> </ul>
	<ul style="list-style-type: none"> <li>Customer's Own Material (COM)</li> <li>Customer's Own Leather (COL)</li> </ul>	<ul style="list-style-type: none"> <li>+\$ 16</li> <li>+\$ 16</li> </ul>	<ul style="list-style-type: none"> <li>► See <i>Understanding Customer's Own Material (COM)</i>, page 324.</li> <li>Add suffix <b>L</b> to style number and specify leather color number.</li> </ul>

► Options, continued on next page

## ► Options, continued from previous page

	Options	U.S. Price	Required to Specify
<b>Surface Materials</b> (continued)	<b>2 Fabric on inner back</b>		
	• Fabric price group 1	No cost	Specify fabric color number.
	• Fabric price group 2	+\$ 8	Specify fabric color number.
	• Fabric price group 3	+\$ 23	Specify fabric color number.
	• Fabric price group 4	+\$ 31	Specify fabric color number.
	• Fabric price group 5	+\$ 39	Specify fabric color number.
	• Fabric price group 6	+\$ 47	Specify fabric color number.
	• Fabric price group 7	+\$ 57	Specify fabric color number.
	• Fabric price group 8	+\$ 71	Specify fabric color number.
	• Fabric price group 9	+\$ 89	Specify fabric color number.
	• Fabric price group 10	+\$103	Specify fabric color number.
	• Leather price group	+\$445	Add suffix <b>L</b> to style number and specify leather color number.
	• Customer's Own Material (COM)	+\$ 16	► See <i>Understanding Customer's Own Material (COM)</i> , page 324.
	• Customer's Own Leather (COL)	+\$ 16	Add suffix <b>L</b> to style number and specify leather color number.
	<b>3 Fabric on outer back</b>		
	• Fabric price group 1	No cost	Specify fabric color number.
	• Fabric price group 2	+\$ 6	Specify fabric color number.
	• Fabric price group 3	+\$ 14	Specify fabric color number.
	• Fabric price group 4	+\$ 24	Specify fabric color number.
	• Fabric price group 5	+\$ 30	Specify fabric color number.
• Fabric price group 6	+\$ 36	Specify fabric color number.	
• Fabric price group 7	+\$ 42	Specify fabric color number.	
• Fabric price group 8	+\$ 53	Specify fabric color number.	
• Fabric price group 9	+\$ 67	Specify fabric color number.	
• Fabric price group 10	+\$ 76	Specify fabric color number.	
• Leather price group	+\$618	Add suffix <b>L</b> to style number and specify leather color number.	
• Customer's Own Material (COM)	+\$ 16	► See <i>Understanding Customer's Own Material (COM)</i> , page 324.	
• Customer's Own Leather (COL)	+\$ 16	Add suffix <b>L</b> to style number and specify leather color number.	
<b>4 Fabric on arm</b>			
• Fabric price group 1	No cost	Specify fabric color number.	
• Fabric price group 2	+\$ 7	Specify fabric color number.	
• Fabric price group 3	+\$ 22	Specify fabric color number.	
• Fabric price group 4	+\$ 30	Specify fabric color number.	
• Fabric price group 5	+\$ 37	Specify fabric color number.	
• Fabric price group 6	+\$ 45	Specify fabric color number.	
• Fabric price group 7	+\$ 53	Specify fabric color number.	
• Fabric price group 8	+\$ 68	Specify fabric color number.	
• Fabric price group 9	+\$ 84	Specify fabric color number.	
• Fabric price group 10	+\$ 95	Specify fabric color number.	
• Leather price group	+\$588	Add suffix <b>L</b> to style number and specify leather color number.	
• Customer's Own Material (COM)	+\$ 16	► See <i>Understanding Customer's Own Material (COM)</i> , page 324.	
• Customer's Own Leather (COL)	+\$ 16	Add suffix <b>L</b> to style number and specify leather color number.	
	<b>High-Pressure Laminate tablet</b>		
	• Open Line laminate	+\$ 67 plus cost of laminate	► See <i>Surface Materials Reference Manual</i> .
	<b>Legs</b>		
	• Brushed Aluminum legs	+\$113	Specify with <i>Brushed Aluminum legs</i> .
	• Solid wood legs	+\$151	Specify with <i>solid wood legs</i> and select 3412 Natural Cherry, 3522 Clear Maple, or 3762 Dark Walnut.
<b>Related Products</b>	• Ganging kit		► Page 233

Tip: Brushed Aluminum legs are adjustable and have 3/4" of height adjustment.

**For Canadian Pricing**

Multiply U.S. Price by the Canadian price factor.

► See page 1 for details.

## ► Specification Information, on next page

Jenny Lounge, continued

► Options, on previous page

**Specification Information**

Style Number LPL	U.S. Base Price	Style Number HPL	U.S. Base Price
---------------------	-----------------	---------------------	-----------------

Style Number LPL	U.S. Base Price	Style Number HPL	U.S. Base Price
---------------------	-----------------	---------------------	-----------------

**With Glides**

**Arm Right**

<b>TS31403</b>	\$1230
----------------	--------

**With Two Casters and Two Glides**

**Arm Right**

<b>TS31403C</b>	\$1278
-----------------	--------

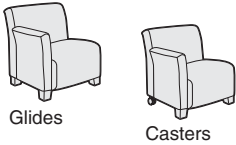

Tip: Casters and tablet arm are not retrofittable on style number TS31403.

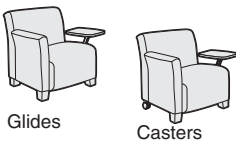

**Arm Right with Tablet Arm**

<b>TS31403T</b>	\$1508	<b>TS31403H</b>	\$1545
-----------------	--------	-----------------	--------

**Arm Right with Tablet Arm**

<b>TS31403CT</b>	\$1556	<b>TS31403CH</b>	\$1593
------------------	--------	------------------	--------

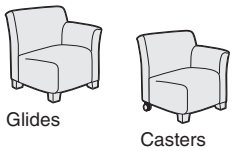

Tip: Casters and tablet arm are not retrofittable on style number TS31404.

**Arm Left**

<b>TS31404</b>	\$1230
----------------	--------

**Arm Left**

<b>TS31404C</b>	\$1278
-----------------	--------

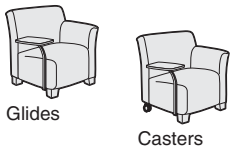

**Arm Left with Tablet Arm with 180°Swivel**

<b>TS31404T</b>	\$1508	<b>TS31404H</b>	\$1545
-----------------	--------	-----------------	--------

**Arm Left with Tablet Arm with 180°Swivel**

<b>TS31404CT</b>	\$1556	<b>TS31404CH</b>	\$1593
------------------	--------	------------------	--------



**For Canadian Pricing**

Multiply U.S. Price by the Canadian price factor.

► See page 1 for details.



Jenny Lounge, continued

Corner

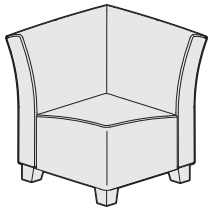

Tip: Jenny lounge chairs are available with multiple fabrics.

▶ See at right to specify.

Tip: When specifying multiple COM fabrics, indicate all surfaces where COM applies. Example: TS31406M with Designtex 1234 on seat, Designtex 5678 on inner back, and Designtex 9012 on outer back.

Tip: When specifying multiple fabrics and leather, specify suffix **M** before suffix **L**. Example: TS31406ML TS31406CML

Standard Includes	Required to Specify
<ul style="list-style-type: none"> <li>▶ Need help? Product details, page 212</li> <li>Fully upholstered lounge chair: fabric price group 1</li> <li>Hard dual-wheel casters or legs with glides: black plastic</li> <li>Shipped fully assembled</li> <li>Meets Cal. 117 requirements</li> </ul>	<ul style="list-style-type: none"> <li>1 Style number</li> <li>2 Fabric color number for upholstery</li> <li>3 Options, if selected (see below)</li> <li>▶ See <i>Surface Materials</i>, page 247.</li> </ul>

Surface Materials	Options	U.S. Price	Required to Specify
	<b>Single upholstery fabric</b>		
	<ul style="list-style-type: none"> <li>Fabric price group 1</li> <li>Fabric price group 2</li> <li>Fabric price group 3</li> <li>Fabric price group 4</li> <li>Fabric price group 5</li> <li>Fabric price group 6</li> <li>Fabric price group 7</li> <li>Fabric price group 8</li> <li>Fabric price group 9</li> <li>Fabric price group 10</li> <li>Leather price group</li> </ul>	<ul style="list-style-type: none"> <li>No cost</li> <li>+\$ 30</li> <li>+\$ 67</li> <li>+\$ 95</li> <li>+\$ 122</li> <li>+\$ 152</li> <li>+\$ 180</li> <li>+\$ 228</li> <li>+\$ 285</li> <li>+\$ 323</li> <li>+\$1991</li> </ul>	<ul style="list-style-type: none"> <li>Specify fabric color number.</li> <li>Specify fabric color number.</li> <li>Specify fabric color number.</li> <li>Specify fabric color number.</li> <li>Specify fabric color number.</li> <li>Specify fabric color number.</li> <li>Specify fabric color number.</li> <li>Specify fabric color number.</li> <li>Specify fabric color number.</li> <li>Specify fabric color number.</li> <li>Add suffix <b>L</b> to style number and specify leather color number.</li> <li>▶ See <i>Understanding Customer's Own Material (COM)</i>, page 324.</li> <li>Add suffix <b>L</b> to style number and specify leather color number.</li> </ul>
	<ul style="list-style-type: none"> <li>Customer's Own Material (COM)</li> <li>Customer's Own Leather (COL)</li> </ul>	<ul style="list-style-type: none"> <li>+\$ 36</li> <li>+\$ 36</li> </ul>	

Multiple upholstery fabrics		Required to Specify
<ul style="list-style-type: none"> <li>Two or more fabrics on different chair components</li> </ul>	<ul style="list-style-type: none"> <li>+\$ 63</li> </ul>	<ul style="list-style-type: none"> <li>Add suffix <b>M</b> to lounge chair style number and select fabric color number for:</li> </ul>
<ul style="list-style-type: none"> <li>▶ See below and at right.</li> </ul>		<ul style="list-style-type: none"> <li>1 Seat</li> <li>2 Inner back</li> <li>3 Outer back</li> <li>Example: TS31406M with T015 on seat, T016 on inner back, and T017 on outer back.</li> </ul>
<b>1 Fabric on seat</b>		<ul style="list-style-type: none"> <li>Specify fabric color number.</li> <li>Specify fabric color number.</li> <li>Specify fabric color number.</li> <li>Specify fabric color number.</li> <li>Specify fabric color number.</li> <li>Specify fabric color number.</li> <li>Specify fabric color number.</li> <li>Specify fabric color number.</li> <li>Specify fabric color number.</li> <li>Specify fabric color number.</li> <li>Add suffix <b>L</b> to style number and specify leather color number.</li> <li>▶ See <i>Understanding Customer's Own Material (COM)</i>, page 324.</li> <li>Add suffix <b>L</b> to style number and specify leather color number.</li> </ul>
<ul style="list-style-type: none"> <li>Fabric price group 1</li> <li>Fabric price group 2</li> <li>Fabric price group 3</li> <li>Fabric price group 4</li> <li>Fabric price group 5</li> <li>Fabric price group 6</li> <li>Fabric price group 7</li> <li>Fabric price group 8</li> <li>Fabric price group 9</li> <li>Fabric price group 10</li> <li>Leather price group</li> </ul>	<ul style="list-style-type: none"> <li>No cost</li> <li>+\$ 11</li> <li>+\$ 32</li> <li>+\$ 42</li> <li>+\$ 56</li> <li>+\$ 69</li> <li>+\$ 82</li> <li>+\$ 105</li> <li>+\$ 128</li> <li>+\$ 147</li> <li>+\$ 969</li> </ul>	
<ul style="list-style-type: none"> <li>Customer's Own Material (COM)</li> <li>Customer's Own Leather (COL)</li> </ul>	<ul style="list-style-type: none"> <li>+\$ 16</li> <li>+\$ 16</li> </ul>	

▶ Options, continued on next page

▶ Detailed dimensions, page 214



**For Canadian Pricing**  
Multiply U.S. Price by the Canadian price factor.  
▶ See page 1 for details.

► Options, continued from previous page

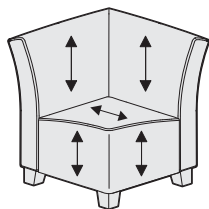

Tip: Standard seat fabric directionality is applied as the diagram above indicates (ex. TS31406).

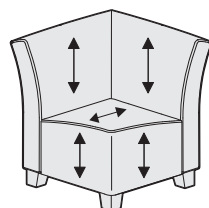

Tip: Reverse seat fabric directionality is applied as the diagram above indicates (ex. TS31426).

Tip: Brushed Aluminum legs are adjustable and have 3/4" of height adjustment.

Options	U.S. Price	Required to Specify
<b>Surface Materials</b> (continued)		
<b>2 Fabric on inner back</b>		
• Fabric price group 1	No cost	Specify fabric color number.
• Fabric price group 2	+\$ 8	Specify fabric color number.
• Fabric price group 3	+\$ 23	Specify fabric color number.
• Fabric price group 4	+\$ 31	Specify fabric color number.
• Fabric price group 5	+\$ 39	Specify fabric color number.
• Fabric price group 6	+\$ 47	Specify fabric color number.
• Fabric price group 7	+\$ 57	Specify fabric color number.
• Fabric price group 8	+\$ 71	Specify fabric color number.
• Fabric price group 9	+\$ 89	Specify fabric color number.
• Fabric price group 10	+\$123	Specify fabric color number.
• Leather price group	+\$445	Add suffix <b>L</b> to style number and specify leather color number.
• Customer's Own Material (COM)	+\$ 16	► See <i>Understanding Customer's Own Material (COM)</i> , page 324.
• Customer's Own Leather (COL)	+\$ 16	Add suffix <b>L</b> to style number and specify leather color number.
<b>3 Fabric on outer back</b>		
• Fabric price group 1	No cost	Specify fabric color number.
• Fabric price group 2	+\$ 6	Specify fabric color number.
• Fabric price group 3	+\$ 14	Specify fabric color number.
• Fabric price group 4	+\$ 24	Specify fabric color number.
• Fabric price group 5	+\$ 30	Specify fabric color number.
• Fabric price group 6	+\$ 36	Specify fabric color number.
• Fabric price group 7	+\$ 42	Specify fabric color number.
• Fabric price group 8	+\$ 53	Specify fabric color number.
• Fabric price group 9	+\$ 67	Specify fabric color number.
• Fabric price group 10	+\$ 76	Specify fabric color number.
• Leather price group	+\$618	Add suffix <b>L</b> to style number and specify leather color number.
• Customer's Own Material (COM)	+\$ 16	► See <i>Understanding Customer's Own Material (COM)</i> , page 324.
• Customer's Own Leather (COL)	+\$ 16	Add suffix <b>L</b> to style number and specify leather color number.
<b>Legs</b>		
• Brushed Aluminum legs	+\$113	Specify with <i>Brushed Aluminum legs</i> .
• Solid wood legs	+\$151	Specify with <i>solid wood legs</i> and select 3412 Natural Cherry, 3522 Clear Maple, or 3762 Dark Walnut.

**Related Products**

• Ganging kit

► Page 233

**Specification Information**

Style Number	U.S. Base Price	Style Number	U.S. Base Price

**Standard Seat Fabric Directionality**

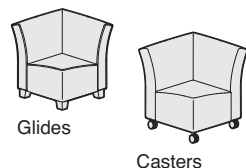

With Glides		With Casters	
<b>TS31406</b>	\$1232	<b>TS31406C</b>	\$1280

**Reverse Seat Fabric Directionality**

With Glides		With Casters	
<b>TS31426</b>	\$1232	<b>TS31426C</b>	\$1280

**For Canadian Pricing**  
Multiply U.S. Price by the Canadian price factor.  
► See page 1 for details.

Jenny Lounge, continued

Club

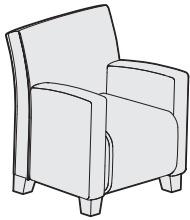

Tip: Jenny lounge chairs are available with multiple fabrics.

▶ See at right to specify.

Tip: When specifying multiple COM fabrics, indicate all surfaces where COM applies. Example: TS31407M with Designtex 1234 on seat, Designtex 5678 on inner back, Designtex 9012 on outer back, and Designtex 9012 on arms.

Tip: When specifying multiple fabrics and leather, specify suffix **M** before suffix **L**. Example: TS31407ML TS31407CML

▶ Detailed dimensions, page 214

 **For Canadian Pricing**  
Multiply U.S. Price by the Canadian price factor.  
▶ See page 1 for details.

Standard Includes	Required to Specify
<ul style="list-style-type: none"> <li>▶ Need help? Product details, page 212</li> <li>Fully upholstered lounge chair with arms: fabric price group 1</li> <li>Deck stitch detail</li> <li>Hard dual-wheel casters or legs with glides: black plastic</li> <li>Shipped fully assembled</li> <li>Meets Cal. 117 requirements</li> </ul>	<ul style="list-style-type: none"> <li>1 Style number</li> <li>2 Fabric color number for upholstery</li> <li>3 Options, if selected (see below)</li> <li>▶ See <i>Surface Materials</i>, page 247.</li> </ul>

Surface Materials	Options	U.S. Price	Required to Specify
	<b>Single upholstery fabric</b>		
	<ul style="list-style-type: none"> <li>Fabric price group 1</li> <li>Fabric price group 2</li> <li>Fabric price group 3</li> <li>Fabric price group 4</li> <li>Fabric price group 5</li> <li>Fabric price group 6</li> <li>Fabric price group 7</li> <li>Fabric price group 8</li> <li>Fabric price group 9</li> <li>Fabric price group 10</li> <li>Leather price group</li> </ul>	<ul style="list-style-type: none"> <li>No cost</li> <li>+\$ 45</li> <li>+\$ 105</li> <li>+\$ 149</li> <li>+\$ 195</li> <li>+\$ 237</li> <li>+\$ 283</li> <li>+\$ 357</li> <li>+\$ 445</li> <li>+\$ 505</li> <li>+\$3077</li> </ul>	<ul style="list-style-type: none"> <li>Specify fabric color number.</li> <li>Specify fabric color number.</li> <li>Specify fabric color number.</li> <li>Specify fabric color number.</li> <li>Specify fabric color number.</li> <li>Specify fabric color number.</li> <li>Specify fabric color number.</li> <li>Specify fabric color number.</li> <li>Specify fabric color number.</li> <li>Specify fabric color number.</li> <li>Specify fabric color number.</li> <li>Add suffix <b>L</b> to style number and specify leather color number.</li> <li>▶ See <i>Understanding Customer's Own Material (COM)</i>, page 324.</li> <li>Add suffix <b>L</b> to style number and specify leather color number.</li> </ul>
	<ul style="list-style-type: none"> <li>Customer's Own Material (COM)</li> <li>Customer's Own Leather (COL)</li> </ul>	<ul style="list-style-type: none"> <li>+\$ 36</li> <li>+\$ 36</li> </ul>	<ul style="list-style-type: none"> <li>Add suffix <b>M</b> to lounge chair style number and select fabric color number for:</li> </ul>

**Multiple upholstery fabrics**

- Two or more fabrics on different chair components
- ▶ See below and at right.

**1 Fabric on seat**

- Fabric price group 1
- Fabric price group 2
- Fabric price group 3
- Fabric price group 4
- Fabric price group 5
- Fabric price group 6
- Fabric price group 7
- Fabric price group 8
- Fabric price group 9
- Fabric price group 10
- Leather price group
- Customer's Own Material (COM)
- Customer's Own Leather (COL)

- No cost
- +\$ 11
- +\$ 32
- +\$ 42
- +\$ 56
- +\$ 69
- +\$ 82
- +\$ 105
- +\$ 128
- +\$ 147
- +\$ 878
- +\$ 16
- +\$ 16

Add suffix **M** to lounge chair style number and select fabric color number for:

- 1 Seat
- 2 Inner back
- 3 Outer back
- 4 Arms

Example: TS31407M with T015 on seat, T016 on inner back, T017 on outer back, and T018 on arms.

- Specify fabric color number.
- Specify fabric color number.
- Specify fabric color number.
- Specify fabric color number.
- Specify fabric color number.
- Specify fabric color number.
- Specify fabric color number.
- Specify fabric color number.
- Specify fabric color number.
- Specify fabric color number.
- Specify fabric color number.
- Add suffix **L** to style number and specify leather color number.
- ▶ See *Understanding Customer's Own Material (COM)*, page 324.
- Add suffix **L** to style number and specify leather color number.

▶ Options, continued on next page

► Options, continued from previous page

Options	U.S. Price	Required to Specify
<b>Surface Materials</b> (continued)		
<b>2 Fabric on inner back</b>		
• Fabric price group 1	No cost	Specify fabric color number.
• Fabric price group 2	+\$ 8	Specify fabric color number.
• Fabric price group 3	+\$ 23	Specify fabric color number.
• Fabric price group 4	+\$ 31	Specify fabric color number.
• Fabric price group 5	+\$ 39	Specify fabric color number.
• Fabric price group 6	+\$ 47	Specify fabric color number.
• Fabric price group 7	+\$ 57	Specify fabric color number.
• Fabric price group 8	+\$ 71	Specify fabric color number.
• Fabric price group 9	+\$ 89	Specify fabric color number.
• Fabric price group 10	+\$ 103	Specify fabric color number.
• Leather price group	+\$ 445	Specify fabric color number. Add suffix <b>L</b> to style number and specify leather color number.
• Customer's Own Material (COM)	+\$ 16	► See <i>Understanding Customer's Own Material (COM)</i> , page 324.
• Customer's Own Leather (COL)	+\$ 16	Add suffix <b>L</b> to style number and specify leather color number.
<b>3 Fabric on outer back</b>		
• Fabric price group 1	No cost	Specify fabric color number.
• Fabric price group 2	+\$ 6	Specify fabric color number.
• Fabric price group 3	+\$ 14	Specify fabric color number.
• Fabric price group 4	+\$ 24	Specify fabric color number.
• Fabric price group 5	+\$ 30	Specify fabric color number.
• Fabric price group 6	+\$ 36	Specify fabric color number.
• Fabric price group 7	+\$ 42	Specify fabric color number.
• Fabric price group 8	+\$ 53	Specify fabric color number.
• Fabric price group 9	+\$ 67	Specify fabric color number.
• Fabric price group 10	+\$ 76	Specify fabric color number.
• Leather price group	+\$ 618	Specify fabric color number. Add suffix <b>L</b> to style number and specify leather color number.
• Customer's Own Material (COM)	+\$ 16	► See <i>Understanding Customer's Own Material (COM)</i> , page 324.
• Customer's Own Leather (COL)	+\$ 16	Add suffix <b>L</b> to style number and specify leather color number.
<b>4 Fabric on arms</b>		
• Fabric price group 1	No cost	Specify fabric color number.
• Fabric price group 2	+\$ 15	Specify fabric color number.
• Fabric price group 3	+\$ 38	Specify fabric color number.
• Fabric price group 4	+\$ 53	Specify fabric color number.
• Fabric price group 5	+\$ 70	Specify fabric color number.
• Fabric price group 6	+\$ 85	Specify fabric color number.
• Fabric price group 7	+\$ 104	Specify fabric color number.
• Fabric price group 8	+\$ 127	Specify fabric color number.
• Fabric price group 9	+\$ 161	Specify fabric color number.
• Fabric price group 10	+\$ 181	Specify fabric color number.
• Leather price group	+\$1177	Specify fabric color number. Add suffix <b>L</b> to style number and specify leather color number.
• Customer's Own Material (COM)	+\$ 16	► See <i>Understanding Customer's Own Material (COM)</i> , page 324.
• Customer's Own Leather (COL)	+\$ 16	Add suffix <b>L</b> to style number and specify leather color number.
<b>Legs</b>		
• Brushed Aluminum legs	+\$ 113	Specify with <i>Brushed Aluminum legs</i> .
• Solid wood legs	+\$ 151	Specify with <i>solid wood legs</i> and select 3412 Natural Cherry, 3522 Clear Maple, or 3762 Dark Walnut.

Tip: Brushed Aluminum legs are adjustable and have 3/4" of height adjustment.

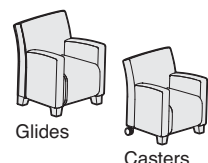

Specification Information

Style Number	U.S. Base Price	Style Number	U.S. Base Price
--------------	-----------------	--------------	-----------------

With Glides		With Two Casters and Two Glides	
TS31407	\$1301	TS31407C	\$1349

Jenny Lounge, continued

Round

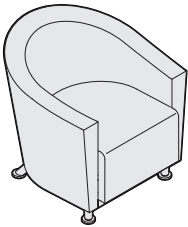

Tip: Jenny Round chairs are available with multiple fabrics.

▶ See at right to specify.

Tip: When specifying multiple COM fabrics, indicate all surfaces where COM applies. Example: TS31407M with Designtex 1234 on seat, Designtex 5678 on inner back, Designtex 9012 on outer back, and Designtex 9012 on arms.

Tip: When specifying multiple fabrics and leather, specify suffix **M** before suffix **L**. Example: TS31409ML TS31409CML

Standard Includes	Required to Specify
<ul style="list-style-type: none"> <li>▶ Need help? Product details, page 212</li> <li>Fully upholstered round chair with arms: fabric price group 1</li> <li>Brushed aluminum legs</li> <li>Shipped fully assembled</li> <li>Meets Cal. 117 requirements</li> </ul>	<ul style="list-style-type: none"> <li>1 Style number</li> <li>2 Fabric color number for upholstery</li> <li>3 Options, if selected (see below)</li> <li>▶ See <i>Surface Materials</i>, page 247.</li> </ul>

Surface Materials	Options	U.S. Price	Required to Specify
	<b>Single upholstery fabric</b>		
	• Fabric price group 1	No cost	Specify fabric color number.
	• Fabric price group 2	+\$ 45	Specify fabric color number.
	• Fabric price group 3	+\$ 106	Specify fabric color number.
	• Fabric price group 4	+\$ 149	Specify fabric color number.
	• Fabric price group 5	+\$ 195	Specify fabric color number.
	• Fabric price group 6	+\$ 237	Specify fabric color number.
	• Fabric price group 7	+\$ 283	Specify fabric color number.
	• Fabric price group 8	+\$ 357	Specify fabric color number.
	• Fabric price group 9	+\$ 445	Specify fabric color number.
	• Fabric price group 10	+\$ 505	Specify fabric color number.
	• Leather price group	+\$3113	Specify fabric color number. Add suffix <b>L</b> to style number and specify leather color number.
	• Customer's Own Material (COM)	+\$ 36	▶ See <i>Understanding Customer's Own Material (COM)</i> , page 324.
	• Customer's Own Leather (COL)	+\$ 36	Add suffix <b>L</b> to style number and specify leather color number.

Surface Materials	Options	U.S. Price	Required to Specify
	<b>Multiple upholstery fabrics</b>		
	• Two or more fabrics on different chair components	+\$ 63	Add suffix <b>M</b> to Round chair style number and select fabric color number for:
	▶ See below and at right.		<ol style="list-style-type: none"> <li>1 Seat</li> <li>2 Inner back</li> <li>3 Outer back</li> </ol> Example: TS31409M with T015 on seat, T016 on inner back, and T017 on outer back.
	<b>1 Fabric on seat</b>		
	• Fabric price group 1	No cost	Specify fabric color number.
	• Fabric price group 2	+\$ 11	Specify fabric color number.
	• Fabric price group 3	+\$ 32	Specify fabric color number.
	• Fabric price group 4	+\$ 42	Specify fabric color number.
	• Fabric price group 5	+\$ 56	Specify fabric color number.
	• Fabric price group 6	+\$ 69	Specify fabric color number.
	• Fabric price group 7	+\$ 82	Specify fabric color number.
	• Fabric price group 8	+\$ 105	Specify fabric color number.
	• Fabric price group 9	+\$ 128	Specify fabric color number.
	• Fabric price group 10	+\$ 147	Specify fabric color number.
	• Leather price group	+\$ 878	Specify fabric color number. Add suffix <b>L</b> to style number and specify leather color number.
	• Customer's Own Material (COM)	+\$ 16	▶ See <i>Understanding Customer's Own Material (COM)</i> , page 324.
	• Customer's Own Leather (COL)	+\$ 16	Add suffix <b>L</b> to style number and specify leather color number.

▶ Options, continued on next page

▶ Detailed dimensions, page 214



**For Canadian Pricing**  
Multiply U.S. Price by the Canadian price factor.  
▶ See page 1 for details.

► Options, continued from previous page

Options	U.S. Price	Required to Specify
<b>Surface Materials</b> (continued)		
<b>② Fabric on inner back</b>		
• Fabric price group 1	No cost	Specify fabric color number.
• Fabric price group 2	+\$ 8	Specify fabric color number.
• Fabric price group 3	+\$ 23	Specify fabric color number.
• Fabric price group 4	+\$ 31	Specify fabric color number.
• Fabric price group 5	+\$ 39	Specify fabric color number.
• Fabric price group 6	+\$ 47	Specify fabric color number.
• Fabric price group 7	+\$ 57	Specify fabric color number.
• Fabric price group 8	+\$ 71	Specify fabric color number.
• Fabric price group 9	+\$ 89	Specify fabric color number.
• Fabric price group 10	+\$103	Specify fabric color number.
• Leather price group	+\$445	Specify fabric color number. Add suffix <b>L</b> to style number and specify leather color number.
• Customer's Own Material (COM)	+\$ 16	► See <i>Understanding Customer's Own Material (COM)</i> , page 324.
• Customer's Own Leather (COL)	+\$ 16	Add suffix <b>L</b> to style number and specify leather color number.
<b>③ Fabric on outer back</b>		
• Fabric price group 1	No cost	Specify fabric color number.
• Fabric price group 2	+\$ 6	Specify fabric color number.
• Fabric price group 3	+\$ 14	Specify fabric color number.
• Fabric price group 4	+\$ 24	Specify fabric color number.
• Fabric price group 5	+\$ 30	Specify fabric color number.
• Fabric price group 6	+\$ 36	Specify fabric color number.
• Fabric price group 7	+\$ 42	Specify fabric color number.
• Fabric price group 8	+\$ 53	Specify fabric color number.
• Fabric price group 9	+\$ 67	Specify fabric color number.
• Fabric price group 10	+\$ 76	Specify fabric color number.
• Leather price group	+\$618	Specify fabric color number. Add suffix <b>L</b> to style number and specify leather color number.
• Customer's Own Material (COM)	+\$ 16	► See <i>Understanding Customer's Own Material (COM)</i> , page 324.
• Customer's Own Leather (COL)	+\$ 16	Add suffix <b>L</b> to style number and specify leather color number.

Specification Information

Style Number	U.S. Base Price
<b>Round</b>	
<b>TS31409</b>	\$1515

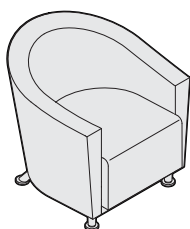

Jenny Lounge



**For Canadian Pricing**

Multiply U.S. Price by the Canadian price factor.

► See page 1 for details.

Jenny Lounge, continued

**With Wood Arms**

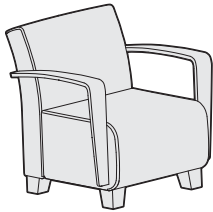

Tip: Jenny lounge chairs are available with multiple fabrics.

▶ See at right to specify.

Tip: When specifying multiple COM fabrics, indicate all surfaces where COM applies. Example: TS31407M with Designtex 1234 on seat, Designtex 5678 on inner back, Designtex 9012 on outer back, and Designtex 9012 on arms.

Tip: When specifying multiple fabrics and leather, specify suffix **M** before suffix **L**. Example: TS31409ML TS31409CML

▶ Detailed dimensions, page 214



**For Canadian Pricing**

Multiply U.S. Price by the Canadian price factor.

▶ See page 1 for details.

Standard Includes	Required to Specify
<ul style="list-style-type: none"> <li>▶ Need help? Product details, page 212</li> <li>Fully upholstered lounge chair: fabric price group 1</li> <li>Plywood arm: maple veneer</li> <li>Deck stitch detail</li> <li>Legs with glides: black plastic</li> <li>Shipped fully assembled</li> <li>Meets Cal. 117 requirements</li> </ul>	<ul style="list-style-type: none"> <li>1 Style number</li> <li>2 Fabric color number for upholstery</li> <li>3 Wood color number for arms</li> <li>4 Options, if selected (see below)</li> <li>▶ See <i>Surface Materials</i>, page 247.</li> </ul>

Surface Materials	Options	U.S. Price	Required to Specify
	<b>Single upholstery fabric</b>		
	<ul style="list-style-type: none"> <li>Fabric price group 1</li> <li>Fabric price group 2</li> <li>Fabric price group 3</li> <li>Fabric price group 4</li> <li>Fabric price group 5</li> <li>Fabric price group 6</li> <li>Fabric price group 7</li> <li>Fabric price group 8</li> <li>Fabric price group 9</li> <li>Fabric price group 10</li> <li>Leather price group</li> </ul>	<ul style="list-style-type: none"> <li>No cost</li> <li>+\$ 30</li> <li>+\$ 67</li> <li>+\$ 95</li> <li>+\$ 122</li> <li>+\$ 152</li> <li>+\$ 180</li> <li>+\$ 228</li> <li>+\$ 285</li> <li>+\$ 323</li> <li>+\$1991</li> </ul>	<ul style="list-style-type: none"> <li>Specify fabric color number.</li> <li>Specify fabric color number.</li> <li>Specify fabric color number.</li> <li>Specify fabric color number.</li> <li>Specify fabric color number.</li> <li>Specify fabric color number.</li> <li>Specify fabric color number.</li> <li>Specify fabric color number.</li> <li>Specify fabric color number.</li> <li>Specify fabric color number.</li> <li>Add suffix <b>L</b> to style number and specify leather color number.</li> <li>▶ See <i>Understanding Customer's Own Material (COM)</i>, page 324.</li> <li>Add suffix <b>L</b> to style number and specify leather color number.</li> </ul>
	<ul style="list-style-type: none"> <li>Customer's Own Material (COM)</li> <li>Customer's Own Leather (COL)</li> </ul>	<ul style="list-style-type: none"> <li>+\$ 36</li> <li>+\$ 36</li> </ul>	

Multiple upholstery fabrics	Options	U.S. Price	Required to Specify
<ul style="list-style-type: none"> <li>▶ Two or more fabrics on different chair components</li> <li>▶ See below and at right.</li> </ul>		<ul style="list-style-type: none"> <li>+\$ 63</li> </ul>	<ul style="list-style-type: none"> <li>Add suffix <b>M</b> to lounge chair style number and select fabric color number for:</li> <li>1 Seat</li> <li>2 Inner back</li> <li>3 Outer back</li> <li>Example: TS31408M with T015 on seat, T016 on inner back, and T017 on outer back.</li> <li>Specify fabric color number.</li> <li>Specify fabric color number.</li> <li>Specify fabric color number.</li> <li>Specify fabric color number.</li> <li>Specify fabric color number.</li> <li>Specify fabric color number.</li> <li>Specify fabric color number.</li> <li>Specify fabric color number.</li> <li>Specify fabric color number.</li> <li>Specify fabric color number.</li> <li>Specify fabric color number.</li> <li>Specify fabric color number.</li> <li>Add suffix <b>L</b> to style number and specify leather color number.</li> <li>▶ See <i>Understanding Customer's Own Material (COM)</i>, page 324.</li> <li>Add suffix <b>L</b> to style number and specify leather color number.</li> </ul>
<b>1 Fabric on seat</b>	<ul style="list-style-type: none"> <li>Fabric price group 1</li> <li>Fabric price group 2</li> <li>Fabric price group 3</li> <li>Fabric price group 4</li> <li>Fabric price group 5</li> <li>Fabric price group 6</li> <li>Fabric price group 7</li> <li>Fabric price group 8</li> <li>Fabric price group 9</li> <li>Fabric price group 10</li> <li>Leather price group</li> </ul>	<ul style="list-style-type: none"> <li>No cost</li> <li>+\$ 11</li> <li>+\$ 32</li> <li>+\$ 42</li> <li>+\$ 56</li> <li>+\$ 69</li> <li>+\$ 82</li> <li>+\$ 105</li> <li>+\$ 128</li> <li>+\$ 147</li> <li>+\$ 951</li> </ul>	
	<ul style="list-style-type: none"> <li>Customer's Own Material (COM)</li> <li>Customer's Own Leather (COL)</li> </ul>	<ul style="list-style-type: none"> <li>+\$ 16</li> <li>+\$ 16</li> </ul>	

▶ Options, continued on next page

## ► Options, continued from previous page

Options	U.S. Price	Required to Specify
<b>Surface Materials</b> (continued)		
<b>② Fabric on inner back</b>		
• Fabric price group 1	No cost	Specify fabric color number.
• Fabric price group 2	+\$ 8	Specify fabric color number.
• Fabric price group 3	+\$ 23	Specify fabric color number.
• Fabric price group 4	+\$ 31	Specify fabric color number.
• Fabric price group 5	+\$ 39	Specify fabric color number.
• Fabric price group 6	+\$ 47	Specify fabric color number.
• Fabric price group 7	+\$ 57	Specify fabric color number.
• Fabric price group 8	+\$ 71	Specify fabric color number.
• Fabric price group 9	+\$ 89	Specify fabric color number.
• Fabric price group 10	+\$103	Specify fabric color number.
• Leather price group	+\$445	Add suffix <b>L</b> to style number and specify leather color number.
• Customer's Own Material (COM)	+\$ 16	► See <i>Understanding Customer's Own Material (COM)</i> , page 324.
• Customer's Own Leather (COL)	+\$ 16	Add suffix <b>L</b> to style number and specify leather color number.
<b>③ Fabric on outer back</b>		
• Fabric price group 1	No cost	Specify fabric color number.
• Fabric price group 2	+\$ 6	Specify fabric color number.
• Fabric price group 3	+\$ 14	Specify fabric color number.
• Fabric price group 4	+\$ 24	Specify fabric color number.
• Fabric price group 5	+\$ 30	Specify fabric color number.
• Fabric price group 6	+\$ 36	Specify fabric color number.
• Fabric price group 7	+\$ 42	Specify fabric color number.
• Fabric price group 8	+\$ 53	Specify fabric color number.
• Fabric price group 9	+\$ 67	Specify fabric color number.
• Fabric price group 10	+\$ 76	Specify fabric color number.
• Leather price group	+\$618	Add suffix <b>L</b> to style number and specify leather color number.
• Customer's Own Material (COM)	+\$ 16	► See <i>Understanding Customer's Own Material (COM)</i> , page 324.
• Customer's Own Leather (COL)	+\$ 16	Add suffix <b>L</b> to style number and specify leather color number.
<b>Legs</b>		
• Brushed Aluminum legs	+\$113	Specify with <i>Brushed Aluminum legs</i> .
• Solid wood legs	+\$151	Specify with <i>solid wood legs</i> and select 3412 Natural Cherry, 3522 Clear Maple, or 3762 Dark Walnut.

Tip: Brushed Aluminum legs are adjustable and have 3/4" of height adjustment.

## Specification Information

Style Number	U.S. Base Price

## With Wood Arms

<b>TS31408</b>	\$1573
----------------	--------

## With Wood Arm Left

<b>TS31428</b>	\$1382
----------------	--------

## With Wood Arm Right

<b>TS31438</b>	\$1382
----------------	--------

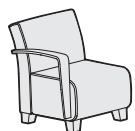

Jenny Lounge, continued

Ottoman

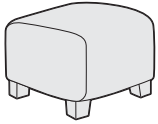

Tip: Hard dual-wheel casters are for use on carpet. Use on hard surfaces, including floor mats, will affect chair stability and may result in personal injury.

Tip: Jenny ottoman is available with multiple fabrics. See at right to specify.

Tip: When specifying multiple COM fabrics, indicate all surfaces where COM applies. Example: TS31405M with Designtex 1234 on seat, front, and back and Designtex 9012 on sides.

Tip: When specifying multiple fabrics and leather, specify suffix **M** before suffix **L**. Example: TS31401ML TS31401CML

Standard Includes	Required to Specify
<ul style="list-style-type: none"> <li>Need help? Product details, page 212</li> <li>Fully upholstered ottoman: fabric price group 1</li> <li>Hard dual-wheel casters or legs with glides: black plastic</li> <li>Meets Cal. 117 requirements</li> </ul>	<ul style="list-style-type: none"> <li>1 Style number</li> <li>2 Fabric color number for upholstery</li> <li>3 Options, if selected (see below)</li> <li>See <i>Surface Materials</i>, page 247.</li> </ul>

Surface Materials	Options	U.S. Price	Required to Specify
	<b>Single upholstery fabric</b>		Specify fabric color number. Specify fabric color number. Specify fabric color number. Specify fabric color number. Specify fabric color number. Specify fabric color number. Specify fabric color number. Specify fabric color number. Specify fabric color number. Specify fabric color number. Add suffix <b>L</b> to style number and specify leather color number. See <i>Understanding Customer's Own Material (COM)</i> , page 324. Add suffix <b>L</b> to style number and specify leather color number.
	• Fabric price group 1	No cost	
	• Fabric price group 2	+\$ 16	
	• Fabric price group 3	+\$ 41	
	• Fabric price group 4	+\$ 60	
	• Fabric price group 5	+\$ 77	
	• Fabric price group 6	+\$ 95	
	• Fabric price group 7	+\$ 113	
	• Fabric price group 8	+\$ 144	
	• Fabric price group 9	+\$ 178	
• Fabric price group 10	+\$ 202		
	• Leather price group	+\$1033	
	• Customer's Own Material (COM)	+\$ 36	Add suffix <b>M</b> to ottoman style number and select fabric color number for: 1 Seat, front, and back 2 Sides Example: TS31405M with T015 on seat, front, and back and T016 on sides.
	• Customer's Own Leather (COL)	+\$ 36	

<b>Multiple upholstery fabrics</b>			
• Two or more fabrics on different components	+\$ 63		
See below and at right.			
<b>1 Fabric on seat, front, and back</b>			
• Fabric price group 1	No cost		Specify fabric color number. Specify fabric color number. Specify fabric color number. Specify fabric color number. Specify fabric color number. Specify fabric color number. Specify fabric color number. Specify fabric color number. Specify fabric color number. Specify fabric color number. Add suffix <b>L</b> to style number and specify leather color number. See <i>Understanding Customer's Own Material (COM)</i> , page 324. Add suffix <b>L</b> to style number and specify leather color number.
• Fabric price group 2	+\$ 11		
• Fabric price group 3	+\$ 32		
• Fabric price group 4	+\$ 45		
• Fabric price group 5	+\$ 58		
• Fabric price group 6	+\$ 71		
• Fabric price group 7	+\$ 84		
• Fabric price group 8	+\$ 108		
• Fabric price group 9	+\$ 135		
• Fabric price group 10	+\$ 152		
• Leather price group	+\$ 712		
• Customer's Own Material (COM)	+\$ 16		
• Customer's Own Leather (COL)	+\$ 16		

Options, continued on next page

Detailed dimensions, page 214



**For Canadian Pricing**  
 Multiply U.S. Price by the Canadian price factor.  
 See page 1 for details.

► Options, continued from previous page

Options		U.S. Price	Required to Specify
Surface Materials (continued)	<b>② Fabric on sides</b>	No cost	Specify fabric color number.
	• Fabric price group 1	+\$ 4	Specify fabric color number.
	• Fabric price group 2	+\$ 9	Specify fabric color number.
	• Fabric price group 3	+\$ 14	Specify fabric color number.
	• Fabric price group 4	+\$ 19	Specify fabric color number.
	• Fabric price group 5	+\$ 25	Specify fabric color number.
	• Fabric price group 6	+\$ 30	Specify fabric color number.
	• Fabric price group 7	+\$ 36	Specify fabric color number.
	• Fabric price group 8	+\$ 45	Specify fabric color number.
	• Fabric price group 9	+\$ 50	Specify fabric color number.
	• Fabric price group 10	+\$363	Specify fabric color number.
	• Leather price group		Add suffix <b>L</b> to style number and specify leather color number.
	• Customer's Own Material (COM)	+\$ 16	► See <i>Understanding Customer's Own Material (COM)</i> , page 324.
• Customer's Own Leather (COL)	+\$ 16	Add suffix <b>L</b> to style number and specify leather color number.	
	<b>Legs</b>		
	• Brushed Aluminum legs	+\$113	Specify with <i>Brushed Aluminum legs</i> .
	• Solid wood legs	+\$151	Specify with <i>solid wood legs</i> and select 3412 Natural Cherry, 3522 Clear Maple, or 3762 Dark Walnut.

Tip: Brushed Aluminum legs are adjustable and have 3/4" of height adjustment.

Specification Information

Style Number	U.S. Base Price	Style Number	U.S. Base Price
<b>With Glides</b>		<b>With Casters</b>	
TS31405	\$559	TS31405C	\$654

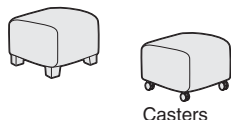

Ganging Kit

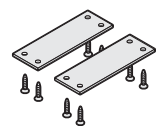

Standard Includes	Required to Specify
<ul style="list-style-type: none"> <li>• Ganging kit</li> <li>• Two plates</li> <li>• Attachment hardware</li> </ul>	Style number

Specification Information

Dimensions D W	Style Number	U.S. Price
2" 6"	TS31410	\$29

Jenny Lounge

 **For Canadian Pricing**  
 Multiply U.S. Price by the Canadian price factor.  
 ► See page 1 for details.

**Occasional Tables**

Standard Includes	Required to Specify
<ul style="list-style-type: none"> <li>Table: Low-Pressure Laminate (LPL) or High-Pressure Laminate (HPL)</li> <li>3 mm edge band: plastic</li> <li>Legs with glides: black plastic</li> </ul>	<ol style="list-style-type: none"> <li>Style number</li> <li>Low-Pressure Laminate or High-Pressure Laminate color number for table, as appropriate</li> <li>Plastic edge band color number for table</li> <li>Options, if selected</li> </ol> <p>▶ See <i>Surface Materials</i>, page 247.</p>

Options	U.S. Price	Required to Specify
<b>Surface Materials</b> High-Pressure Laminate worksurfaces <ul style="list-style-type: none"> <li>Open Line laminate</li> </ul>	+\$ 67 plus cost of laminate	▶ See <i>Surface Materials Reference Manual</i> .
<b>Legs</b> <ul style="list-style-type: none"> <li>Brushed aluminum legs</li> <li>Solid wood legs</li> </ul>	+\$113 +\$151	Specify with <i>brushed aluminum legs</i> . Specify with <i>solid wood legs</i> and select 3412 Natural Cherry, 3522 Clear Maple, or 3762 Dark Walnut.

*Tip: Brushed aluminum legs are adjustable and have 3/4" of height adjustment.*

*Tip: There may be sheen or texture differences when using LPL and HPL in adjacent applications. Please use caution when mixing and matching different worksurface types.*

Specification Information						
Dimensions			Style Number	U.S. Base Price	Style Number	U.S. Base Price
D	W	H				

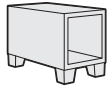

**End Table**

26½"	13½"	17"	<b>TS31415L</b>	\$332	<b>TS31415H</b>	\$367

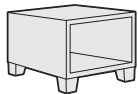

**Coffee Table**

26½"	26½"	17"	<b>TS31416L</b>	\$452	<b>TS31416H</b>	\$487



**For Canadian Pricing**  
 Multiply U.S. Price by the Canadian price factor.  
 ▶ See page 1 for details.

---

# Understanding and Specifying Lincoln Lounge Lounge Seating

## Product Details

Lincoln Lounge	236
Dimensions	238

## Specifying

Lincoln Lounge	240
----------------	-----

# Lincoln Lounge

► Specifying, page 142

**Lincoln Lounge seat, back and top of arms** are leather. All other surfaces are simulated leather.

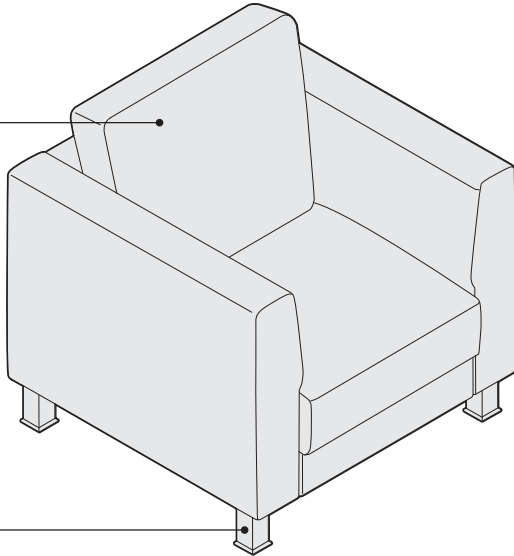

**Supports** up to 225 pounds.

## Product Details

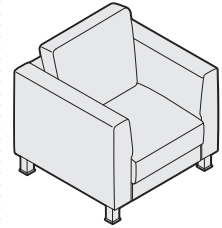

**Legs** need to be assembled onto the lounge seating.

**The Jenny tablet arm** cannot be installed on Lincoln chairs.

## Surface Materials

**Post legs** are available in aluminum or black.

**Seat and back** are leather. Remaining chair is simulated leather.

## Dimensions

► Page 238



# Dimensions

## Lincoln Lounge

Features	Overall Depth	Width	Height	Functional Seat Depth	Seat Width	Seat Height from Floor	Back Width	Back Height from Seat	Width Between Arms
<b>Lincoln Lounge</b>									
<b>Lounge Seating</b>									
	32"	33"	34 <sup>1</sup> / <sub>2</sub> "	20 <sup>5</sup> / <sub>8</sub> "	21 <sup>1</sup> / <sub>2</sub> "	16 <sup>7</sup> / <sub>8</sub> "	21 <sup>3</sup> / <sub>8</sub> "	20 <sup>9</sup> / <sub>16</sub> "	23"

• Arm  
Rest  
Width

• Arm  
Rest  
Length

• Arm  
Height  
to Floor

5<sup>1</sup>/<sub>16</sub>"

7<sup>7</sup>/<sub>8</sub>"

10<sup>3</sup>/<sub>4</sub>"

# Lincoln Lounge

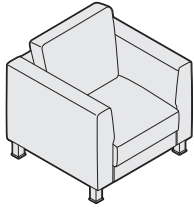

Standard Includes		Required to Specify
<ul style="list-style-type: none"> <li>▶ Need help? Product details, page 236</li> </ul>	<ul style="list-style-type: none"> <li>• Seat and back: Leather</li> <li>• Balance of the chair: simulated leather</li> <li>• Post legs: 8043 Clear Anodized Aluminum or 0835 Black</li> <li>• Shipped ready to assemble</li> <li>• Meets Cal. 117 requirements</li> </ul>	<ul style="list-style-type: none"> <li>1 Style number</li> <li>2 Upholstery color number for seat and back:                             <ul style="list-style-type: none"> <li>L304 Black Leather</li> <li>L305 Brown Leather</li> </ul> </li> </ul>

## Specification Information

Style Number	U.S. Price

### Lincoln Lounge with Post Legs

<b>TS31601</b>	\$1037

▶ Detailed dimensions, page 238



**For Canadian Pricing**  
 Multiply U.S. Price by the Canadian price factor.  
 ▶ See page 1 for details.

---

# Understanding and Specifying alight Lounge

## Lounge Seating

### Product Details

alight Lounge	242
Dimensions	244

### Specifying

alight Lounge	245
---------------	-----

# alight Lounge

**alight** comes fully upholstered as a bench, round, or corner ottoman. Alight supports up to 225 pounds.  
▶ Specifying, page 245

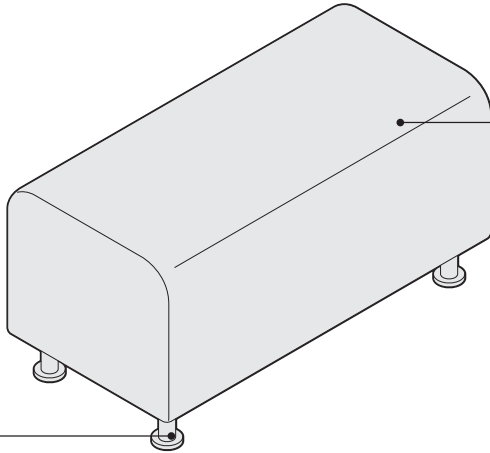

**alight seating** comes fully assembled.

**Legs** come standard brushed aluminum with an option of wood legs and low profile glides.

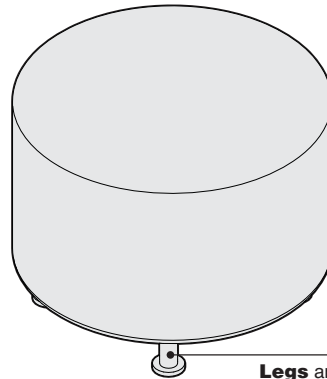

**Legs** are height adjustable.

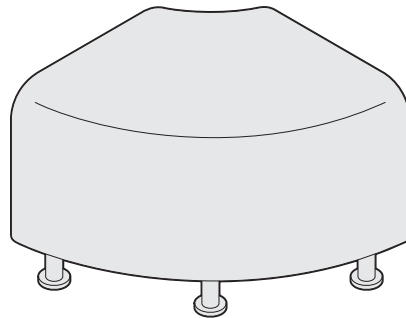

**alight tables** are available as an end table or coffee table.  
▶ Specifying, page 243

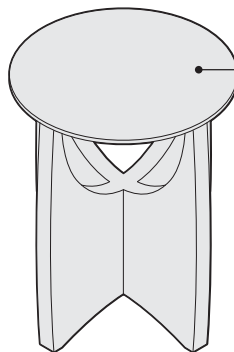

**alight tables** have a glass top.

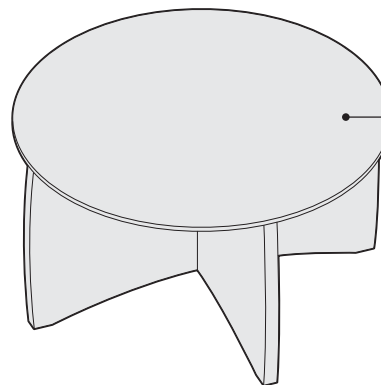

**alight tables** require minor assembly.

**Product Details**

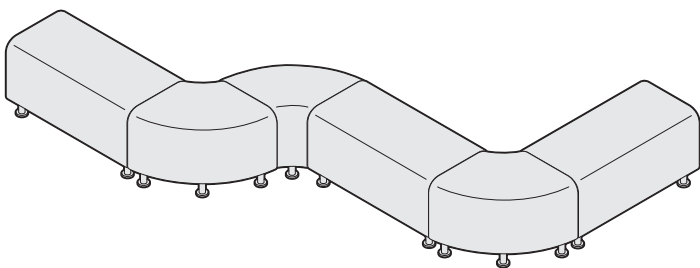
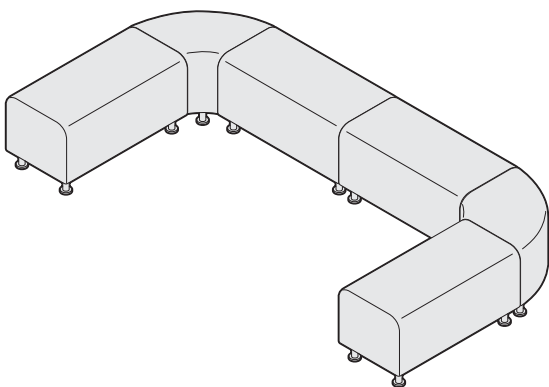
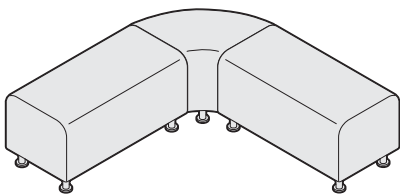

**Combine** alight bench with corner ottoman to create a variety of configurations.

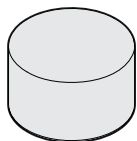

**Adding** low profile glide option reduces the overall height of the ottoman from 19" to 16".

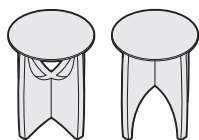

**alight end table base** can be reversed creating two unique looks.

**Surface Materials**

**Due to natural variations in wood**, finished products may vary in color, texture, and grain.

**Finish 3522 Clear Maple** is a clear coat and therefore the natural variations in wood will be visible.

**Dimensions**

▶ Page 244

# Dimensions

alight Lounge

**Features**      • **Overall**  
: **Depth** **Width** **Height**  
:  
:  
:

## alight Lounge

### Lounge Seating

Round	24"	24"	19"
Corner Ottoman	18"	31"	19"
Bench Ottoman	18"	36"	19"

Standard Includes		Required to Specify
<ul style="list-style-type: none"> <li>▶ Need help? Product details, page 242</li> </ul>	<ul style="list-style-type: none"> <li>Fully upholstered ottoman: fabric price group 1</li> <li>Four adjustable-height legs: brushed aluminum</li> <li>Meets Cal. 117 requirements</li> </ul>	<ul style="list-style-type: none"> <li>1 Style number</li> <li>2 Fabric color number for upholstery</li> <li>3 Options, if selected (see below)</li> <li>▶ See <i>Surface Materials</i>, page 247.</li> </ul>

Options	U.S. Price	Required to Specify
<b>Surface Materials</b>	<b>Upholstery</b> <ul style="list-style-type: none"> <li>Fabric price group 1: No cost</li> <li>Fabric price group 2: +\$ 16</li> <li>Fabric price group 3: +\$ 41</li> <li>Fabric price group 4: +\$ 60</li> <li>Fabric price group 5: +\$ 77</li> <li>Fabric price group 6: +\$ 95</li> <li>Fabric price group 7: +\$113</li> <li>Fabric price group 8: +\$144</li> <li>Fabric price group 9: +\$178</li> <li>Fabric price group 10: +\$202</li> <li>Customer's Own Material (COM): +\$ 36</li> </ul>	<ul style="list-style-type: none"> <li>Specify fabric color number.</li> <li>Specify fabric color number.</li> <li>Specify fabric color number.</li> <li>Specify fabric color number.</li> <li>Specify fabric color number.</li> <li>Specify fabric color number.</li> <li>Specify fabric color number.</li> <li>Specify fabric color number.</li> <li>Specify fabric color number.</li> <li>Specify fabric color number.</li> <li>▶ See <i>Understanding Customer's Own Material (COM)</i>, page 324.</li> </ul>
	<b>Legs</b> <ul style="list-style-type: none"> <li>Solid maple wood legs: +\$ 34</li> </ul>	<ul style="list-style-type: none"> <li>Specify with <i>solid maple wood legs</i> and select 3412 Natural Cherry, 3522 Clear Maple, or 3762 Dark Walnut.</li> </ul>
<b>Glides</b> <ul style="list-style-type: none"> <li>Low profile glide</li> </ul>	No cost	Specify with <i>low profile glides</i> .

Specification Information	
Style Number	U.S. Base Price

Round Ottoman	
TS34401	\$515
:	:

Corner Ottoman	
TS34402	\$585
:	:

Bench Ottoman	
TS34403	\$644
:	:

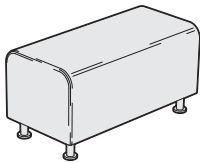
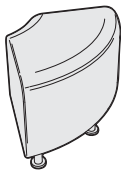
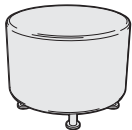

▶ Detailed dimensions, page 244



**For Canadian Pricing**  
 Multiply U.S. Price by the Canadian price factor.  
 ▶ See page 1 for details.

**Ganging Kit**

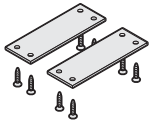

Standard Includes	Required to Specify
<ul style="list-style-type: none"> <li>• Ganging kit</li> <li>• Two plates</li> <li>• Attachment hardware</li> </ul>	Style number

**Specification Information**

• Dimensions		• Style	• U.S.
D	W	Number	Price
2"	6"	<b>TS31410</b>	\$29

**Occasional Tables**

	Standard Includes	Required to Specify
<p>▶ Need help? Product details, page 242</p>	<ul style="list-style-type: none"> <li>• Table: maple veneer base</li> <li>• Veneer edge band to match base</li> <li>• 3/8" clear glass top</li> <li>• Glides</li> </ul>	<ul style="list-style-type: none"> <li>1 Style number</li> <li>2 Wood color number for base</li> <li>▶ See <i>Surface Materials</i>, page 247.</li> </ul>

**Specification Information**

• Dimensions			• Style	• U.S.
D	W	H	Number	Price

**End Table**

18"	18"	23"	<b>TS34410T</b>	\$600
-----	-----	-----	-----------------	-------

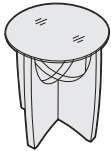

**Coffee Table**

30"	30"	17"	<b>TS34411T</b>	\$774
-----	-----	-----	-----------------	-------



**For Canadian Pricing**  
 Multiply U.S. Price by the Canadian price factor.  
 ▶ See page 1 for details.

# Surface Materials

► For Surface Materials matrices for all product lines, see page 305.

## Paint

### Steelcase Surfaces

Applies to:

- Scoop
- 4799 Platinum Metallic
- 7207 Black Textured
- 7241 Arctic White Textured

Applies to:

- Jenny tablet arm
- 7207 Black

Applies to:

- Lincoln Lounge legs
- 8043 Clear Anodized Aluminum
- 0835 Black **E**

## Plastic

### Steelcase Surfaces

Applies to:

- Jenny tablet arm
- Jenny end table
- Jenny coffee table
- 6000 Black\*
- 6001 Coffee
- 6009 Arctic White\*
- 6034 Natural Cherry
- 6036 Medium Cherry
- 6037 Winter on Maple
- 6038 Blonde on Maple
- 6041 Natural Walnut
- 6045 Medium Mahogany on Walnut **E**
- 6052 Milk
- 6053 Seagull\*
- 6213 Acacia
- 6219 Clear Oak
- 6234 Clear Cherry\*
- 6237 Clear Maple
- 6242 Virginia Walnut\*
- 6243 Blackwood\*
- 6245 Clear Walnut\*
- 6246 Warm Oak\* **E**
- 6249 Platinum Solid
- 6615 Grey Value 5
- 6619 Ice **E**
- 6631 Cream
- 6635 Dawn **E**
- 6636 Mist\*
- 6654 Sand\*
- 6655 Warm White\*
- 6676 Marbled White
- 6677 Chocolate Walnut
- 6678 Marbled Cherry
- 6689 Brushed Silver\* **E**
- 6694 Slate
- 6695 Midnight
- 6697 Fog
- 6698 Fieldstone

Applies to:

- Scoop
- 6618 White
- 6682 Cobblestone

Applies to:

- Buoy
- 6009 Arctic White
- 6205 Black
- 6333 Picasso
- 6335 Wasabi
- 6337 Element
- 6338 Chili

Applies to:

- Buoy Base
- 6527 Merle

Applies to:

- Shortcut shell
- 6009 Arctic White
- 6059 Sterling Dark Solid
- 6205 Black
- 6333 Picasso
- 6335 Wasabi
- 6337 Element
- 6338 Chili

## Laminate

### Steelcase Surfaces

#### Low-Pressure Laminate

Applies to:

- Jenny tablet arm
- Jenny end table
- Jenny coffee table

#### Fiber Laminate

- 2L50 Vanadium Fiber LPL
- 2L52 Tungsten Fiber LPL

#### Metallic Laminate

- 2L03 Brushed Silver LPL

#### Solid Laminate

- 247L Black Version 2 LPL
- 2L30 Arctic White LPL
- 2L83 Seagull LPL
- 2L85 Dune LPL

#### Woodgrain Laminate

- 25L1 Winter on Maple LPL
- 25L5 Virginia Walnut LPL
- 25L6 Blackwood LPL
- 25L8 Clear Walnut LPL
- 25L9 Warm Oak LPL **E**
- 262L Marbled Maple LPL
- 264L Chocolate Walnut LPL
- 267L Marbled Cherry Version 2 LPL
- 26L1 Natural Cherry Version 2 LPL
- 2LAK Clear Oak LPL
- 2LAT Acacia LPL
- 2L09 Clear Maple LPL

#### High-Pressure Laminate

Applies to:

- Jenny tablet arm
- Jenny end table
- Jenny coffee table

#### Fiber Laminate

- 2850 Vanadium Fiber
- 2851 Rhyme Fiber **E**
- 2852 Tungsten Fiber
- 2854 Vellum Fiber
- 2859 Novell Fiber
- 2860 Granite Fiber
- 2861 Coconut Fiber
- 2862 Stucco Fiber

#### Metallic Laminate

- 2503 Brushed Silver

#### Micro Laminate

- 2920 Marl Micro
- 2921 Gypsum Micro
- 2922 Clay Micro
- 2923 Shadow Micro **E**

#### Patina Laminate

- 2870 Blonde Bronze Patina
- 2871 Blackened Bronze Patina
- 2873 Instant Iron Patina

#### Solid Laminate

- 2722 Cream **E**
- 2730 Arctic White
- 2746 Black
- 2759 Warm White **E**
- 2811 Mist **E**
- 2883 Seagull
- 2884 Milk
- 2885 Dune

#### Speckle Laminate

- 2820 Coffee Speckle
- 2822 Woodrose Speckle **E**
- 2823 Driftwood Speckle
- 2824 Smoke Speckle
- 2825 Vanadium Speckle

#### Woodgrain Laminate

- 2406 Clear Cherry
- 2412 Natural Cherry
- 2422 Medium Cherry
- 2511 Winter on Maple
- 2538 Clear Walnut
- 2539 Warm Oak **E**
- 2592 Blonde on Maple
- 2714 Natural Walnut
- 2772 Medium Mahogany on Walnut **E**
- 2HAK Clear Oak
- 2HAT Acacia

#### Turnstone Laminate Collection

- 2535 Virginia Walnut
- 2536 Blackwood
- 2612 Marbled Maple
- 2614 Chocolate Walnut
- 2615 Marbled Cherry

*Note: Some wood veneer finishes and woodgrain laminates share the same name. Because of the difference in materials, veneers and laminates of the same name are not an exact match but do coordinate with each other.*

## Custom Surfaces

### Open Line Laminate (OLL)

This service allows you to order non-standard laminate at an additional processing fee of \$67 U.S. per work surface or top, plus the cost of the laminate.

When processing orders for Open Line laminate on turnstone products, specify 2900 in the laminate finish field and enter the OLL manufacturer information. Enter the required edge finish as you would a standard laminate.

**Edge color** for the Open Line laminate on turnstone products must be determined by the dealer and customer before orders can be entered. Specify appropriate 2K finish number.

*Tip: Standard laminates being used in the Open Line Laminate program to obtain a different edge detail will be charged the Open Line laminate upcharge; however, no additional charges for the laminate will be applied.*

### Laminate Approval and Material Requirements

To confirm whether a particular laminate has already been tested for use on a specific Steelcase product or to determine material square foot requirements:

- Visit [www.steelcase.com](http://www.steelcase.com)

**For additional information,** refer to the *Steelcase Surface Materials Reference Manual*.

## Wood

### Steelcase Surfaces

Applies to:

- Jenny wood legs
- Jenny wood arm
- aight wood legs
- aight end table
- aight coffee table
- 3412 Natural Cherry **E**
- 3522 Clear Maple
- 3762 Dark Walnut

*Tip: Due to natural variations in wood, finished products may vary in color, texture and grain.*

*Tip: Established finishes are available for delivery in 15 business days.*

**E** = Established

## Surface Materials, continued

**Upholstery****Steelcase Surfaces**

Not every upholstery is available on every chair. Please refer to the upholstery matrix on page 323 before specifying.

**Price Group 1**

Buzz2  
Jacks **E**  
Link  
Playground **E**

**Price Group 2**

Cogent: Connect  
Cogent: Geode Seating **E**  
Cogent: Geode Vertical **E**  
Cogent: Trails  
Crosswalk **E**  
Nitelights  
Seating Vinyl **E**  
Spyder **E**  
Stand In  
Zoe2 **E**

**Price Group 3**

Gaja – C2C  
Imperma  
Redeem  
Retrieve  
Texel

**Price Group 6**

Brisa

**Price Group 7**

Steelcut Trio

**Select Surfaces**

Applies to:  
• Buoy

**Price Group 4**

DesignTex Rocket  
2693-201 Gold  
2693-301 Flame  
2693-502 Lime  
2693-702 Red Orange

**Price Group 6**

DesignTex Delaine  
3249-302 Crimson  
3249-403 Indigo  
3249-503 Moss  
3249-801 Marble  
3249-802 Graphite

*Tip: Established finishes are available for delivery in 15 business days.*

**E** = Established

**turnstone Leather****Steelcase Surfaces**

Applies to:  
• Lincoln Lounge  
L304 Black  
L305 Brown

**Reply Select Defaults**

Reply seat color number defaults based on the mesh back selection.

Mesh back:	Default seat:
AR01 Grey	5G64 Alpine
AR02 Black	5F17 Black
AR03 White	5F17 Black
AR04 Red	5G57 Rouge
AR05 Royal Blue	5F17 Black
AR06 Apple Green	5G59 Meadow
AR07 Orange	5F17 Black
AR08 Bright Purple	5F17 Black
AR09 Sable	5G51 Sable

**cobi Select Defaults**

cobi seat color number defaults based on the mesh back selection.

Back:	Default seat:
5017 Tangerine	5S17 Tangerine
5018 Scarlet	5S18 Scarlet
5019 Concord	5S19 Concord
5020 Maya Blue	5S20 Maya Blue
5021 Blue Jay	5S21 Blue Jay
5023 Wasabi	5S23 Wasabi
5024 Nickel	5S24 Nickel
5025 Graphite	5S25 Graphite
5026 Licorice	5S26 Licorice
5028 Root Beer	5S28 Root Beer

**Buoy**

Buoy plastic color for body based on the style number.

Style number:	Plastic color:
TSBUOYWHITE	6009 Arctic White
TSBUOYBLACK	6205 Black
TSBUOYBLUE	6333 Picasso
TSBUOYGREEN	6335 Wasabi
TSBUOYGREY	6337 Element
TSBUOYRED	6338 Chili

Fabric:	Price Group:
All Buzz2	1
All Chainmail	2
All Cogent: Connect	2
DesignTex Rocket 2693–201 Gold	4
DesignTex Rocket 2693–301 Flame	4
DesignTex Rocket 2693–502 Lime	4
DesignTex Rocket 2693–702 Red Orange	4
All Bo Peep	5
DesignTex Delaine 3249–302 Crimson	6
DesignTex Delaine 3249–403 Indigo	6
DesignTex Delaine 3249–504 Moss	6
DesignTex Delaine 3249–801 Marble	6
DesignTex Delaine 3249–802 Graphite	6

### Uno Select Defaults

Uno seat color number defaults based on the back selection.

Back:	Default seat:
5F17 Black	5F17 Black
5G51 Sable	5G51 Sable
5G57 Rouge	5G57 Rouge
5G59 Meadow	5G59 Meadow
5G64 Alpine	5G64 Alpine
5S15 Coconut	5S15 Coconut
5S16 Tumeric	5S16 Tumeric
5S17 Tangerine	5S17 Tangerine
5S18 Scarlet	5S18 Scarlet
5S19 Concorn	5S19 Concorn
5S20 Maya Blue	5S20 Maya Blue
5S21 Blue Jay	5S21 Blue Jay
5S23 Wasabi	5S23 Wasabi
5S24 Nickel	5S24 Nickel
5S25 Graphite	5S25 Graphite
5S26 Licorice	5S26 Licorice
5S28 Root Beer	5S28 Root Beer
5S98 Canary	5S98 Canary

### Select Surfaces

**For information on products within Select Surfaces,** including accent paints and fabrics from Designtex, Gabriel, Kvadrat, and Pollack, please refer to the *Surface Materials Reference Manual* or visit [Steelcase.com/selectsurfaces](http://Steelcase.com/selectsurfaces).

### Custom Surfaces

#### Price Group COM (Customer's Own Material)

#### Fabric Approval and Yardage

To confirm whether a particular COM material has already been tested for use on a specific Steelcase product or to determine actual yardage requirements:

- Visit [www.steelcase.com](http://www.steelcase.com)

**For additional information regarding Customer's Own Material,** call 1.888.STEELCASE.

### Custom Surfaces

#### Customer's Own Material (COM) Program

The Customer's Own Material (COM) program offers the opportunity for customers to select fabrics that are not offered through the standard Steelcase surface materials program for use on Steelcase products. Once approved, you can place your order. Steelcase will facilitate the entire ordering process and give you a production schedule. Steelcase will order the COM fabric directly from the textile manufacturer. For up-to-date information regarding fabric test results for all COM fabrics and details regarding yardage requirements for most seating lines, visit the COM website on [www.steelcase.com](http://www.steelcase.com). COMs are not covered under the Steelcase warranty.

#### Soil Retardants

Soil retardants are treatments that provide long-term soil and stain resistance to a fabric without affecting the shade or the integrity of the fabric. The following Steelcase Textiles and turnstone Collection by Designtex fabrics are available pre-treated with soil retardant:

- Jacks
- Link
- Spyder



---

# Tables



## Statement of Line



### Product Details

<b>Table Component Facts</b>	<b>253</b>
<b>Simple Tables</b>	<b>254</b>



### Specifying

<b>Table Components</b>	<b>255</b>
Power Access and Cable Management	<b>257</b>
<b>Simple Tables</b>	<b>258</b>
<b>Sweeper</b>	
Martini Table	<b>260</b>
<b>Jenny</b>	
Occasional Tables	<b>261</b>
<b>alight Lounge</b>	
Occasional Tables	<b>262</b>



<b>Surface Materials</b>	<b>263</b>
--------------------------	------------

# Statement of Line

## Table Components

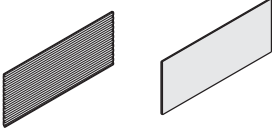

**Desk-Mounted Screens**  
▶ Page 255

## Simple Tables

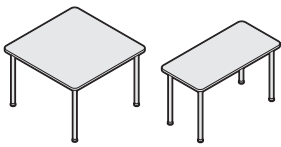

**Square and Rectangular**  
▶ Page 258



**Round**  
▶ Page 258

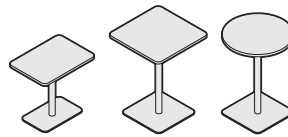

**Pedestal**  
▶ Page 259

## Sweeper Martini

**Table:**



**Martini**  
▶ Page 260

## Jenny

**Tables:**

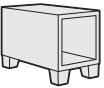

**End Table**  
▶ Page 261

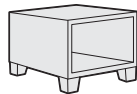

**Coffee Table**  
▶ Page 261

## alight

**Tables:**

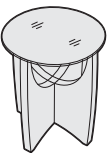

**End Table**  
▶ Page 262



**Coffee Table**  
▶ Page 262

# Table Component Facts

► Specifying, page 255

**Screens** can be attached above the worksurface to the left, right, and rear sides of table desks.

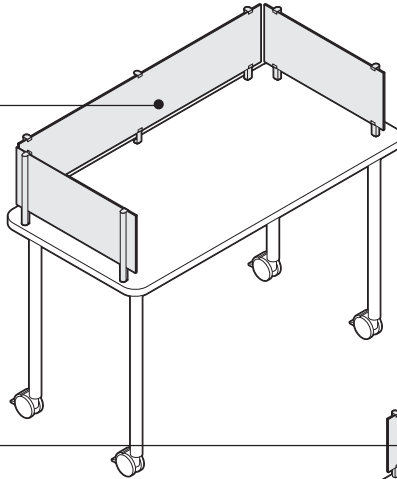

**Screen** attaches to the rear of rectangular table desk top.

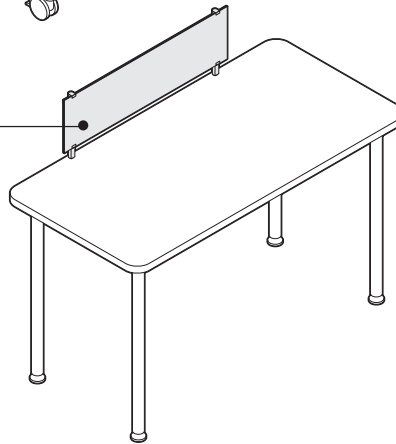

## Product Details

**Screens**, 6" smaller than table desks, do not extend full width or full depth of worksurface.

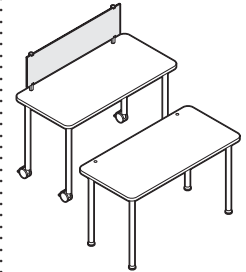

**Table desk tops** are shipped without screen holes. To attach screens, holes must be drilled on site using the supplied template. Plugs are available through Service Parts (TS5YGMTSR) when screens are not in use and have been removed from the top.

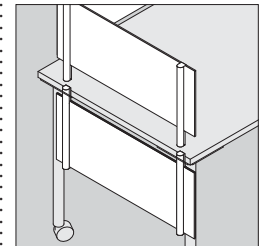

**Screen** attaches above the worksurface for use as a privacy panel or below the worksurface for use as a modesty panel. Mounting brackets, ordered separately, must be used when attaching screens above and below a worksurface.  
► Page 256

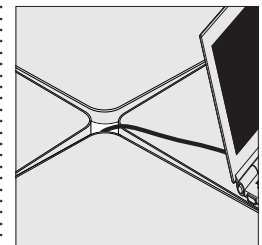

**Rectangular and square table tops** offer slightly crowned edges that leave a gap to allow power cord routing when two or more tables are used together.  
► Specifying, page 258

# Simple Tables

► Specifying, page 216

**Table tops** are 1 1/8" thick with edge band color default to match laminate.

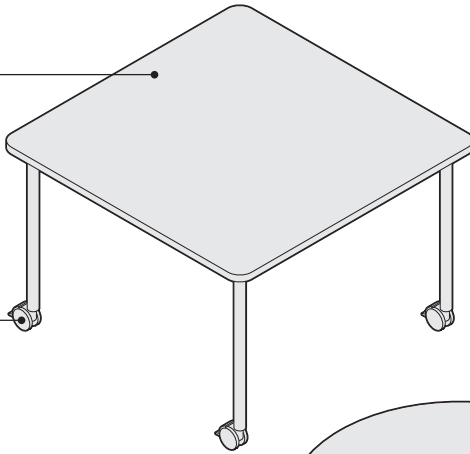

**Rectangular table tops** come with two crowned edges on longer sides.

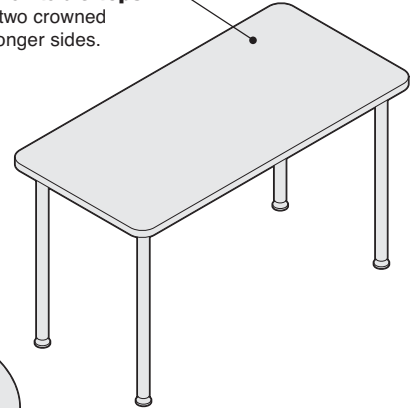

**Casters** are available as an option on square and rectangular post leg tables. Come in a package of four (two locking and two non-locking).

**Tables** are 28 1/2" H.

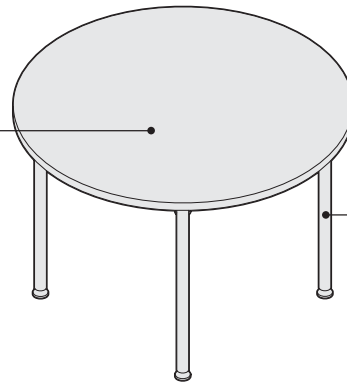

**Post legs** are 1 1/2" in diameter and come standard with glides. The glide is 1 1/2" long and provides 1" of leveling.

**Square table tops** come with all four edges crowned.

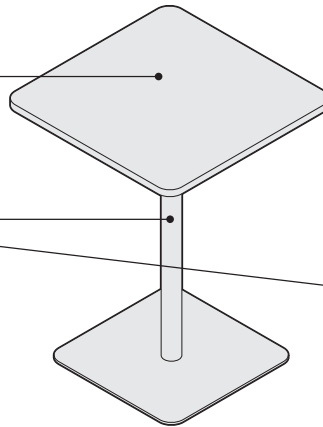

**41" H base** is used to create standing-height tables in cafeterias or general meeting spaces. ► Specifying, page 259

**Table tops** are 1 1/8" thick with edge band color default to match laminate.

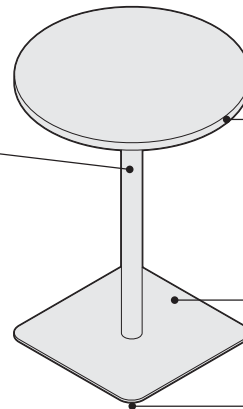

**Base** is 22"W x 22"D.

**Glides** are standard but not adjustable.

**Simple Lounge Table** is 25 1/2"H to work well with Campfire Lounges or Bivi Rumble Seat. ► Specifying, page 259

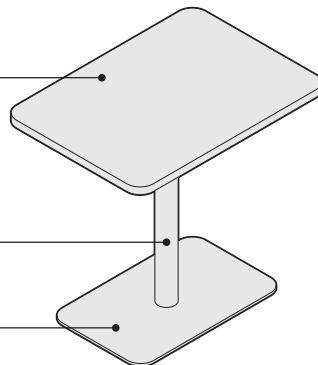

**Column** is 2 3/4" in diameter.

**Base** is 15"W x 23"D.

# Table Components

## Desk-Mounted Screens

For Use Above or Below the Worksurface

Standard Includes		Required to Specify
<ul style="list-style-type: none"> <li>▶ Need help? Product details, page 253</li> </ul>	<ul style="list-style-type: none"> <li>• Translucent screen, if selected: plastic</li> <li>• Slatwall screen, if selected: paint price group 1</li> </ul>	<ul style="list-style-type: none"> <li>1 Style number</li> <li>2 Color number for translucent screen, if selected</li> <li>3 Paint color number for slatwall screen, if selected</li> <li>4 Options, if selected (see below)</li> <li>▶ See <i>Surface Materials</i>, page 263.</li> </ul>

Options	U.S. Price	Required to Specify
<b>Surface Materials</b> <ul style="list-style-type: none"> <li>• <b>Slatwall screen</b></li> <li>• Paint price group 1</li> <li>• Paint price group 2</li> </ul>	No cost +\$16	Specify paint color number. Specify paint color number.
<b>Related Products</b> <ul style="list-style-type: none"> <li>• Mounting brackets</li> <li>• Privacy-modesty adapters</li> </ul>		▶ Page 256 ▶ Page 256

*Tip: Mounting brackets must be ordered with screens.*

Specification Information				
Dimensions	Style			U.S. Base Price
	D	W	H	
:	:	:	:	:
:	:	:	:	:

Translucent Screens				
Dimensions	Style Number	U.S. Base Price		
1/4" 18" 12"	<b>TS5YTS1218</b>	\$141		
1/4" 27" 12"	<b>TS5YTS1227</b>	\$153		
1/4" 30" 12"	<b>TS5YTS1230</b>	\$166		
1/4" 36" 12"	<b>TS5YTS1236</b>	\$195		
1/4" 44" 12"	<b>TS5YTS1244</b>	\$237		
1/4" 60" 12"	<b>TS5YTS1260</b>	\$248		
1/4" 18" 18"	<b>TS5YTS1818</b>	\$153		
1/4" 27" 18"	<b>TS5YTS1827</b>	\$196		
1/4" 30" 18"	<b>TS5YTS1830</b>	\$250		
1/4" 36" 18"	<b>TS5YTS1836</b>	\$278		
1/4" 44" 18"	<b>TS5YTS1844</b>	\$290		
1/4" 60" 18"	<b>TS5YTS1860</b>	\$321		
:	:	:		

Slatwall Screens				
Dimensions	Style Number	U.S. Base Price		
1/4" 18" 12"	<b>TS5YSL1218</b>	\$176		
1/4" 26 3/4" 12"	<b>TS5YSL1226</b>	\$219		
1/4" 30" 12"	<b>TS5YSL1230</b>	\$235		
1/4" 36" 12"	<b>TS5YSL1236</b>	\$259		
1/4" 43 1/2" 12"	<b>TS5YSL1244</b>	\$289		
1/4" 60" 12"	<b>TS5YSL1260</b>	\$339		
:	:	:		

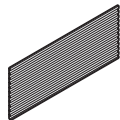
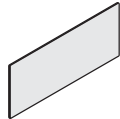

 **For Canadian Pricing**  
Multiply U.S. Price by the Canadian price factor.  
▶ See page 1 for details.

Table Components, continued

**Screen Mounting Brackets and Adapters**

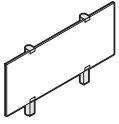

*Tip: Package of three mounting brackets is to be used with 60"W screens only. Package of two mounting brackets is for use with all other applications.*

Standard Includes	Required to Specify
<ul style="list-style-type: none"> <li>▶ Need help? Product details, page 253</li> <li>• Mounting brackets and hardware: paint price group 1</li> </ul>	<ul style="list-style-type: none"> <li>1 Style number</li> <li>2 Paint color number for mounting brackets and hardware</li> <li>3 Options, if selected (see below)</li> <li>▶ See <i>Surface Materials</i>, page 263.</li> </ul>

Options	U.S. Price	Required to Specify
<b>Surface Materials</b> <ul style="list-style-type: none"> <li>• Paint price group 1</li> <li>• Paint price group 2</li> </ul>	No cost +\$10	Specify paint color number. Specify paint color number.

**Specification Information**

• Dimensions	• Style	• U.S.
D    W    H	Number	Base Price
:	:	:
:	:	:

**Package of Two Mounting Brackets**

1½"	2"	15"	<b>TS5YMB212</b>	\$145
1½"	3"	21"	<b>TS5YMB218</b>	\$161
:	:	:	:	:

**Package of Three Mounting Brackets**

1½"	2"	15"	<b>TS5YMB312</b>	\$193
1½"	3"	21"	<b>TS5YMB318</b>	\$200
:	:	:	:	:

Standard Includes	Required to Specify
<ul style="list-style-type: none"> <li>• Package of two privacy-modesty adapters</li> </ul>	Style number

**Specification Information**

• Height	• Style	• U.S.
: <th style="background-color: #2c3e50; color: white;">Number</th> <th style="background-color: #2c3e50; color: white;">Price</th>	Number	Price
:	:	:

*Tip: Order privacy-modesty adapter when attaching one screen directly above or below another.*

**Package of Two Privacy-Modesty Adapters**

4"	<b>TS5YMBADP</b>	\$21
:	:	:



**For Canadian Pricing**  
 Multiply U.S. Price by the Canadian price factor.  
 ▶ See page 1 for details.

# Power Access and Cable Management

## Skeleton Bone Wire Manager

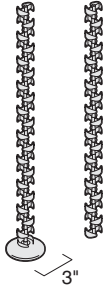

Standard Includes	Required to Specify
-------------------	---------------------

- Wire manager: black plastic
- Attachment hardware

Style number

Specification Information				
• Dimensions			• Style	• U.S.
D	W	H	Number	Price

Skeleton Bone Wire Manager				
----------------------------	--	--	--	--

1½"	1¾"	38"	<b>TS5SKLBNE</b>	\$169
-----	-----	-----	------------------	-------

Skeleton Bone Wire Manager Extension				
--------------------------------------	--	--	--	--

1½"	1¾"	36"	<b>TS5SKEXT</b>	\$144
-----	-----	-----	-----------------	-------

## Wire Manager



Tip: Attaches under work-surfaces with screws or around leg.

Standard Includes	Required to Specify
-------------------	---------------------

- Package of four wire managers
- Attachment package

Style number

Specification Information				
• Dimensions			• Style	• U.S.
D	W	H	Number	Price

½"	8"	½"	<b>TS5LEGCLP</b>	\$48
----	----	----	------------------	------



**For Canadian Pricing**  
 Multiply U.S. Price by the Canadian price factor.  
 ▶ See page 1 for details.

# Simple Tables

## Square and Rectangular Tables

Standard Includes		Required to Specify
<ul style="list-style-type: none"> <li>▶ Need help? Product details, page 254</li> </ul>	<ul style="list-style-type: none"> <li>• 1 1/8" thick table top: Low-Pressure Laminate (LPL)</li> <li>• Edge band: default color to match laminate</li> <li>• Post legs: paint</li> <li>• Glides</li> </ul>	<ol style="list-style-type: none"> <li>1 Style number</li> <li>2 Low-Pressure Laminate color number for table top</li> <li>3 Paint color number for legs</li> <li>4 Options, if selected see below</li> </ol> <ul style="list-style-type: none"> <li>▶ See <i>Surface Materials</i>, page 263.</li> </ul>

Options	U.S Price	Required to Specify
<b>Casters</b> <ul style="list-style-type: none"> <li>• Four casters (two locking and two non-locking)</li> </ul>	+\$41	Specify <i>with four casters</i> .

Specification Information				
Dimensions			Style	U.S.
D	W	H	Number	Base Price

### Square Table

42"	42"	28 1/2"	<b>TS4W4242</b>	\$513
-----	-----	---------	-----------------	-------

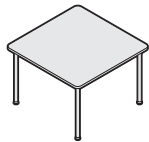

### Rectangular Tables

24"	48"	28 1/2"	<b>TS4W2448</b>	\$455
-----	-----	---------	-----------------	-------

30"	60"	28 1/2"	<b>TS4W3060</b>	\$534
-----	-----	---------	-----------------	-------

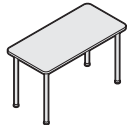

## Round Table

Standard Includes		Required to Specify
<ul style="list-style-type: none"> <li>▶ Need help? Product details, page 254</li> </ul>	<ul style="list-style-type: none"> <li>• 1 1/8" thick table top: Low-Pressure Laminate (LPL)</li> <li>• Edge band: default color to match laminate</li> <li>• Post legs: paint</li> <li>• Glides</li> </ul>	<ol style="list-style-type: none"> <li>1 Style number</li> <li>2 Low-Pressure Laminate color number for table top</li> <li>3 Paint color number for legs</li> </ol> <ul style="list-style-type: none"> <li>▶ See <i>Surface Materials</i>, page 263.</li> </ul>

Specification Information				
Dimensions		Style	U.S.	
Dia.	H	Number	Price	

42"	28 1/2"	<b>TS4WRND42</b>	\$513
-----	---------	------------------	-------



Tip: Glides are 1 1/2" long and provide 1" of leveling.

 **For Canadian Pricing**  
 Multiply U.S. Price by the Canadian price factor.  
 ▶ See page 1 for details.

## Pedestal Tables

Standard Includes		Required to Specify
<ul style="list-style-type: none"> <li>▶ Need help? Product details, page 254</li> </ul>	<ul style="list-style-type: none"> <li>• 1 1/8" thick table top: Low-Pressure Laminate (LPL)</li> <li>• Edge band: default color to match laminate</li> <li>• Pedestal base: paint</li> </ul>	<ul style="list-style-type: none"> <li>1 Style number</li> <li>2 Low-Pressure Laminate color number for table top</li> <li>3 Paint color number for pedestal base</li> <li>▶ See <i>Surface Materials</i>, page 263.</li> </ul>

### Specification Information

Dimensions			Style	U.S.
D	W	H	Number	Price

#### Lounge Table

22"	30"	25 1/2"	<b>TS4WLNGE</b>	\$554
-----	-----	---------	-----------------	-------

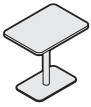

#### Square Stand-Up Table

30"	30"	42"	<b>TS4WCAFE3030</b>	\$616
-----	-----	-----	---------------------	-------

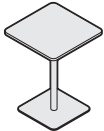

#### Round Stand-Up Table

30"	30"	42"	<b>TS4WCAFERND30</b>	\$616
-----	-----	-----	----------------------	-------



**For Canadian Pricing**  
 Multiply U.S. Price by the Canadian price factor.  
 ▶ See page 1 for details.

# Sweeper Martini Table X10/15



Standard Includes	Required to Specify
-------------------	---------------------

- Durable body: plastic
- Shipped fully assembled

- 1 Style number
- 2 Plastic color number for table
- ▶ See *Surface Materials*, page 263.

Specification Information				
• Dimensions			• Style	• U.S.
D	W	H	Number	Price

• Dimensions			• Style	• U.S.
D	W	H	Number	Price
18"	18"	23 1/2"	<b>TS39150</b> X10/15	\$145



**For Canadian Pricing**  
 Multiply U.S. Price by the  
 Canadian price factor.  
 ▶ See page 1 for details.

X10/15 = Last order entry  
 October 18, 2015

# Jenny Occasional Tables

Standard Includes	Required to Specify
<ul style="list-style-type: none"> <li>Table: Low-Pressure Laminate (LPL) or High-Pressure Laminate (HPL)</li> <li>3 mm edge band: plastic</li> <li>Legs with glides: black plastic</li> </ul>	<ol style="list-style-type: none"> <li>Style number</li> <li>Low-Pressure Laminate or High-Pressure Laminate color number for table, as appropriate</li> <li>Plastic edge band color number for table</li> <li>Options, if selected (see below)</li> </ol> <p>▶ See <i>Surface Materials</i>, page 263.</p>

*Tip: Brushed Aluminum legs are adjustable and have 3/4" of height adjustment.*

*Tip: There may be sheen or texture differences when using LPL and HPL in adjacent applications. Please use caution when mixing and matching different worksurface types.*

Options	U.S. Price	Required to Specify
<b>Surface Materials</b> ▶ Page 263	<b>High-Pressure Laminate worksurfaces</b> • Open Line laminate +\$ 67 plus cost of laminate	▶ See <i>Surface Materials Reference Manual</i> .
	<b>Legs</b> • Brushed Aluminum legs +\$113 • Solid maple wood legs +\$151	Specify with <i>Brushed Aluminum legs</i> . Specify with <i>solid maple wood legs</i> and select 3412 Natural Cherry, 3522 Clear Maple, or 3762 Dark Walnut.

### Specification Information

Dimensions			Style Number	U.S. Base Price	Style Number	U.S. Base Price
D	W	H	LPL		HPL	

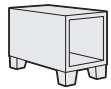

End Table						
26 1/2"	13 1/2"	17"	<b>TS31415L</b>	\$332	<b>TS31415H</b>	\$367

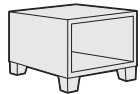

Coffee Table						
26 1/2"	26 1/2"	17"	<b>TS31416L</b>	\$452	<b>TS31416H</b>	\$487

 **For Canadian Pricing**  
 Multiply U.S. Price by the Canadian price factor.  
 ▶ See page 1 for details.

# alight Lounge

## Occasional Tables

*Tip: Due to natural variations in wood, finished products may vary in color, texture and grain.*

*Tip: Finish 3522 Clear Maple is a clear coat and therefore the natural variations in wood will be visible.*

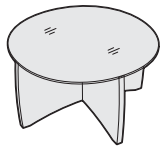
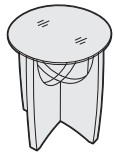

Standard Includes	Required to Specify
<ul style="list-style-type: none"> <li>• Table: maple veneer base</li> <li>• 3 mm edge band to match table</li> <li>• Clear glass top</li> <li>• Glides</li> </ul>	<ul style="list-style-type: none"> <li>1 Style number</li> <li>2 Wood color number for base</li> <li>▶ See <i>Surface Materials</i>, page 263.</li> </ul>

### Specification Information

• Dimensions			• Style	• U.S.
D	W	H	Number	Price

#### End Table

18"	18"	23"	<b>TS34410T</b>	\$600
-----	-----	-----	-----------------	-------

#### Coffee Table

30"	30"	17"	<b>TS34411T</b>	\$774
-----	-----	-----	-----------------	-------



#### For Canadian Pricing

Multiply U.S. Price by the Canadian price factor.

▶ See page 1 for details.

# Surface Materials

► For Surface Materials matrices for all product lines, see page 305.

## Laminate

### Steelcase Surfaces

#### Low-Pressure Laminate

- Applies to:
- Jenny end table
  - Jenny coffee table

#### Fiber Laminate

- 2L50 Vanadium Fiber LPL
- 2L52 Tungsten Fiber LPL

#### Metallic Laminate

- 2L03 Brushed Silver LPL

#### Solid Laminate

- 247L Black Version 2 LPL
- 2L30 Arctic White LPL
- 2L83 Seagull LPL
- 2L85 Dune LPL

#### Woodgrain Laminate

- 25L1 Winter on Maple LPL
- 25L5 Virginia Walnut LPL
- 25L6 Blackwood LPL
- 25L8 Clear Walnut LPL
- 25L9 Warm Oak LPL **E**
- 262L Marbled Maple LPL
- 264L Chocolate Walnut LPL
- 267L Marbled Cherry Version 2 LPL
- 26L1 Natural Cherry Version 2 LPL
- 2LAK Clear Oak LPL
- 2LAT Acacia LPL
- 2L09 Clear Maple LPL

- Applies to:
- Simple tables top
  - 25L5 Virginia Walnut LPL
  - 25L6 Blackwood LPL
  - 25L8 Clear Walnut LPL
  - 25L9 Warm Oak LPL
  - 2L30 Arctic White LPL

#### High-Pressure Laminate

- Applies to:
- Jenny end table
  - Jenny coffee table

*Tip: Established finishes are available for delivery in 15 business days.*

**E** = Established

#### Fiber Laminate

- 2850 Vanadium Fiber
- 2851 Rhyme Fiber **E**
- 2852 Tungsten Fiber
- 2854 Vellum Fiber
- 2859 Novell Fiber
- 2860 Granite Fiber
- 2861 Coconut Fiber
- 2862 Stucco Fiber

#### Metallic Laminate

- 2503 Brushed Silver

#### Micro Laminate

- 2920 Marl Micro
- 2921 Gypsum Micro
- 2922 Clay Micro
- 2923 Shadow Micro **E**

#### Patina Laminate

- 2870 Blonde Bronze Patina
- 2871 Blackened Bronze Patina
- 2873 Instant Iron Patina

#### Solid Laminate

- 2722 Cream **E**
- 2730 Arctic White
- 2746 Black
- 2759 Warm White **E**
- 2811 Mist **E**
- 2883 Seagull
- 2884 Milk
- 2885 Dune

#### Speckle Laminate

- 2820 Coffee Speckle
- 2822 Woodrose Speckle **E**
- 2823 Driftwood Speckle
- 2824 Smoke Speckle
- 2825 Vanadium Speckle

#### Woodgrain Laminate

- 2406 Clear Cherry
- 2412 Natural Cherry
- 2422 Medium Cherry
- 2511 Winter on Maple
- 2538 Clear Walnut
- 2539 Warm Oak **E**
- 2592 Blonde on Maple
- 2714 Natural Walnut
- 2772 Medium Mahogany on Walnut **E**
- 2HAK Clear Oak
- 2HAT Acacia

#### Turnstone Laminate Collection

- 2535 Virginia Walnut
- 2536 Blackwood
- 2612 Marbled Maple
- 2614 Chocolate Walnut
- 2615 Marbled Cherry

*Note: Some wood veneer finishes and woodgrain laminates share the same name. Because of the difference in materials, veneers and laminates of the same name are not an exact match but do coordinate with each other.*

#### Custom Surfaces

##### Open Line Laminate (OLL)

This service allows you to order non-standard laminate at an additional processing fee of \$67 U.S. per worksurface or top, plus the cost of the laminate.

When processing orders for Open Line laminate on turnstone products, specify 2900 in the laminate finish field and enter the OLL manufacturer information. Enter the required edge finish as you would a standard laminate.

**Edge color** for the Open Line laminate on turnstone products must be determined by the dealer and customer before orders can be entered. Specify appropriate 2K finish number. *Tip: Standard laminates being used in the Open Line Laminate program to obtain a different edge detail will be charged the Open Line laminate upcharge; however, no additional charges for the laminate will be applied.*

##### Laminate Approval and Material Requirements

To confirm whether a particular laminate has already been tested for use on a specific Steelcase product or to determine material square foot requirements:

- Visit [www.steelcase.com](http://www.steelcase.com)

**For additional information,** refer to the *Steelcase Surface Materials Reference Manual*.

## Plastic

### Steelcase Surfaces

- Applies to:
- Jenny end table edge band
  - Jenny coffee table edge band
  - 6000 Black\*
  - 6001 Coffee
  - 6009 Arctic White\*
  - 6034 Natural Cherry
  - 6036 Medium Cherry
  - 6037 Winter on Maple
  - 6038 Blonde on Maple
  - 6041 Natural Walnut
  - 6045 Medium Mahogany on Walnut **E**
  - 6052 Milk
  - 6053 Seagull\*
  - 6213 Acacia
  - 6219 Clear Oak
  - 6234 Clear Cherry\*
  - 6237 Clear Maple
  - 6242 Virginia Walnut\*
  - 6243 Blackwood\*
  - 6245 Clear Walnut\*
  - 6246 Warm Oak\* **E**
  - 6249 Platinum Solid
  - 6615 Grey Value 5
  - 6619 Ice **E**
  - 6631 Cream
  - 6635 Dawn **E**
  - 6636 Mist\*
  - 6654 Sand\*
  - 6655 Warm White\*
  - 6676 Marbled White
  - 6677 Chocolate Walnut
  - 6678 Marbled Cherry
  - 6689 Brushed Silver\* **E**
  - 6694 Slate
  - 6695 Midnight
  - 6697 Fog
  - 6698 Fieldstone
- \*These solid color and wood grain edge colors are a polyolefin blend, PVC-free material for 3 mm and 1 mm edge bandings.

- Applies to:
- Translucent screens
  - 6505 Frosted White
  - 6507 Frosted Green

- Applies to:
- Sweeper Martini table
  - 627T Black
  - 628T Natural
  - 631T Dark Grey

## Wood

### Steelcase Surfaces

- Applies to:
- Jenny wood legs
  - alight tables
  - 3412 Natural Cherry **E**
  - 3522 Clear Maple
  - 3762 Dark Walnut

*Tip: Due to natural variations in wood, finished products may vary in color, texture, and grain.*

## Paint

### Steelcase Surfaces

- Applies to:
- Screen mounting brackets
  - Slatwall screens

#### Price Group 1

- 7207 Black
- 7225 Sand
- 7241 Arctic White
- 7243 Seagull

#### Price Group 2

- 4750 Champagne Metallic
- 4798 Sterling Metallic
- 4799 Platinum Metallic
- 7246 Midnight Metallic

- Applies to:
- Simple tables post legs
  - Simple tables pedestal base
  - 4140 Arctic White
  - 4799 Platinum Metallic
  - 7246 Midnight Metallic



# Details

## Ergonomic Worktools

<b>Statement of Line</b>	<b>266</b>	<b>Lighting</b>	
		SOTO LED Lights	<b>291</b>
		Mini SOTO LED Light	<b>291</b>
<b>Organizational Worktools</b>		<b>Computer Support Tools</b>	
<b>Slatwall</b>		<b>Keyboard Assemblies</b>	
Freestanding Slatwall Stanchions	<b>272</b>	Stella Keyboard Assemblies	<b>292</b>
Slatwall Tiles	<b>273</b>	Lift and Lock Keyboard Assemblies	<b>294</b>
Slatwall Panel-Mount Brackets	<b>274</b>	<b>Technology Worktools and Cable Management</b>	
Slatwall Wall-Mount Brackets	<b>274</b>	Freestanding In-Line Document Support	<b>296</b>
<b>SlatRail</b>		Adjustable Foot Rest	<b>296</b>
Freestanding SlatRail Stanchions	<b>275</b>	Vertical Non-Locking CPU Cradle	<b>296</b>
SlatRail	<b>276</b>	Vertical Processor Sling	<b>297</b>
SlatRail Panel-Mount Brackets	<b>277</b>	CPU Trolley	<b>297</b>
SlatRail Wall-Mount Brackets	<b>277</b>	<b>Flat Panel Monitor Arms and Supports</b>	
<b>Slatwall, SlatRail, and Freestanding Worktools</b>		Eyesite Flat Panel Arm Support Assemblies	<b>298</b>
Letter Tray	<b>278</b>	Eyesite Mounting Bracket	<b>300</b>
Binder Holder	<b>278</b>	CF Series Flat Panel Monitor Arms and Supports	<b>300</b>
Hanging Brackets	<b>279</b>	FYI Single Flat Panel Monitor Arm and Supports with Mounting Brackets	<b>303</b>
Pen/Pencil Cup	<b>279</b>	<b>Height-Adjustable Tables</b>	
Double Square Dish	<b>280</b>	Series 5 Height-Adjustable Worksurfaces	<b>304</b>
Personal Shelf	<b>280</b>		
Telephone Caddy	<b>281</b>		
Utility Hook	<b>281</b>		
Flat Top Hanger	<b>282</b>		
<b>SOTO Worktools</b>			
Rails	<b>283</b>		
Cableways	<b>285</b>		
Shelves	<b>286</b>		
Pile Box	<b>288</b>		
Landscape Letter Box	<b>288</b>		
Tool Box	<b>288</b>		
Diagonal File Box	<b>289</b>		
Utility Box	<b>289</b>		
Personal Box	<b>290</b>		
Storage Box, Set of Three	<b>290</b>		

# Statement of Line

## Slatwall

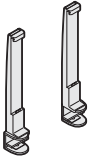

Specifying  
▶ Page 272

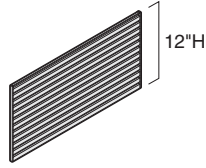

Specifying  
▶ Page 273

## Freestanding Slatwall Stanchions

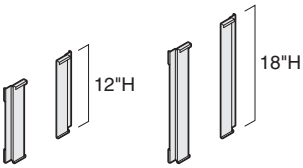

Specifying  
▶ Page 274

## Slatwall Tiles

	24"W	30"W	36"W	42"W	45"W	48"W	60"W
12"H	●	●	●	●	●	●	●

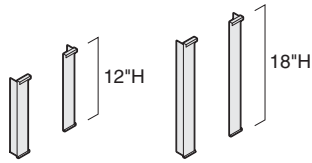

Specifying  
▶ Page 274

## Slatwall Panel-Mount Brackets

12"H	18"H
●	●

## Slatwall Wall-Mount Brackets

12"H	18"H
●	●

## SlatRail

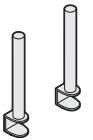

Specifying  
▶ Page 275

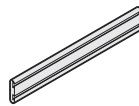

Specifying  
▶ Page 276

## Freestanding SlatRail Stanchions



Specifying  
▶ Page 277

## SlatRail

24"W	30"W	36"W	42"W	45"W	48"W	60"W
●	●	●	●	●	●	●



Specifying  
▶ Page 277

## SlatRail Panel-Mount Brackets

## SlatRail Wall-Mount Brackets

**Slatwall, SlatRail, and Freestanding Worktools**

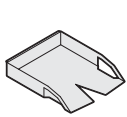

**10" Portrait Letter Tray**  
Specifying  
▶ Page 278



**Binder Holder**  
Specifying  
▶ Page 278

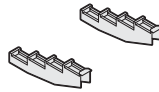

**Hanging Brackets**  
Specifying  
▶ Page 279



**Pen/Pencil Cup**  
Specifying  
▶ Page 279



**Double Square Dish**  
Specifying  
▶ Page 280

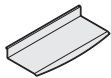

**Personal Shelf**  
Specifying  
▶ Page 280



**Telephone Caddy**  
Specifying  
▶ Page 281



**Utility Hook**  
Specifying  
▶ Page 281



**Flat Top Hanger**  
Specifying  
▶ Page 282

**SOTO Worktools**



Specifying  
▶ Page 283

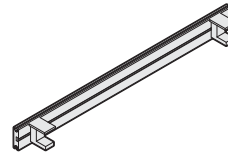

Specifying  
▶ Page 284

**SOTO Rails**

28"W   34"W   40"W   46"W   52"W   58"W   64"W



**SOTO Rails For Use with Tour**

52"W   58"W   64"W

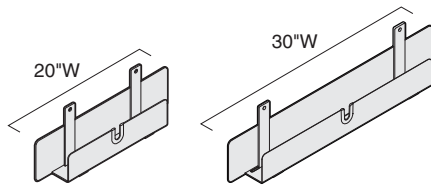

Specifying  
▶ Page 285

**SOTO Cableways**

20"W   30"W



**SOTO Worktools, continued**

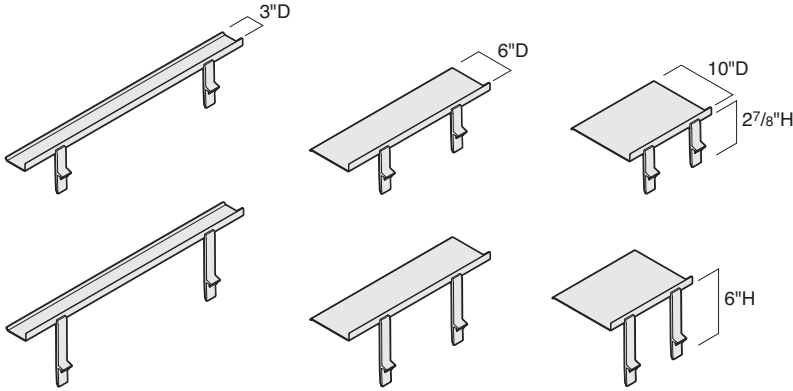

Specifying  
▶ Page 286

**SOTO Shelves**

	14\"W	24\"W	36\"W
3\"D	●		●
6\"D	●	●	
10\"D	●	●	

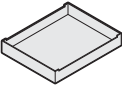

**SOTO Pile Box**  
Specifying  
▶ Page 288

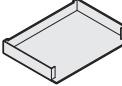

**SOTO Landscape Letter Box**  
Specifying  
▶ Page 288



**SOTO Tool Box**  
Specifying  
▶ Page 288

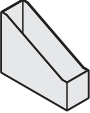

**SOTO Diagonal File Box**  
Specifying  
▶ Page 289



**SOTO Utility Box**  
Specifying  
▶ Page 289



**SOTO Personal Box**  
Specifying  
▶ Page 290

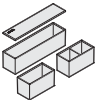

**SOTO Storage Boxes Set of Three**  
Specifying  
▶ Page 290

## Lighting

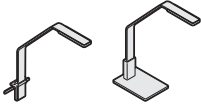

**SOTO LED Lights**  
Specifying  
▶ Page 291



**Mini SOTO LED Light**  
Specifying  
▶ Page 291

## Keyboard Assemblies

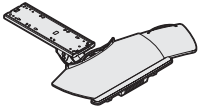

**Slider Keyboard Platform with Stella Mechanism**  
Specifying  
▶ Pages 292-292

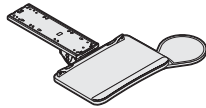

**Jules Keyboard Platform with Stella Mechanism**  
Specifying  
▶ Pages 292-292

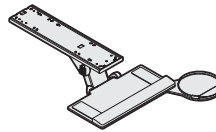

**19" Keyboard Platform with Lift and Lock Mechanism**  
Specifying  
▶ Pages 294-295

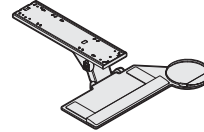

**Enviro Keyboard Platform with Lift and Lock Mechanism**  
Specifying  
▶ Pages 294-295

## Technology Worktools and Cable Management

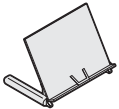

**Freestanding In-Line Document Support**  
Specifying  
▶ Page 296

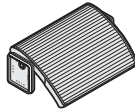

**Adjustable Foot Rest**  
Specifying  
▶ Page 296

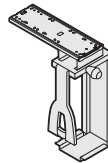

**Vertical Non-Locking CPU Cradle**  
Specifying  
▶ Page 296

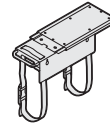

**Vertical Processor Sling**  
Specifying  
▶ Page 297

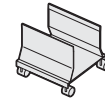

**CPU Trolley**  
Specifying  
▶ Page 297

---

## Eyesite Flat Panel Monitor Arm Support Assemblies



**Eyesite Single Display Support**

Specifying  
▶ Page 298

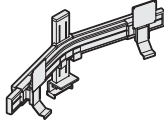

**Eyesite Dual Display Support**

Specifying  
▶ Page 298

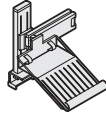

**Eyesite Single Laptop Support**

Specifying  
▶ Page 299

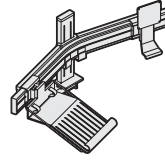

**Eyesite Dual Laptop Support**

Specifying  
▶ Page 299

---

## Eyesite Mounting Bracket



**Bivi Bracket**

Specifying  
▶ Page 300

---

## CF Series Flat Panel Monitor Arms and Supports

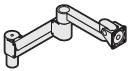

**Standard Arm**

Specifying  
▶ Page 300



**Single-Arm Flat Panel Monitor Pole Mount**

Specifying  
▶ Page 301

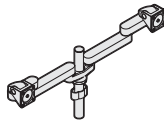

**Double-Arm Flat Panel Monitor Pole Mount**

Specifying  
▶ Page 301



**Desk-Clamp/Grommet Bracket**

Specifying  
▶ Page 302



**Through-Mount Bracket**

Specifying  
▶ Page 302

---

## FYI Flat Panel Monitor Arm

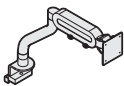

**FYI Single Flat Panel Monitor Arm and Supports with Mounting Brackets**

Specifying  
▶ Page 303

---

### Series 5 Height-Adjustable Worksurfaces

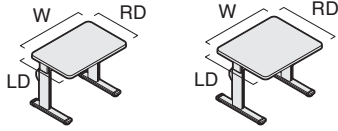

Specifying  
▶ Page 304

---

### Rectangular Worksurfaces

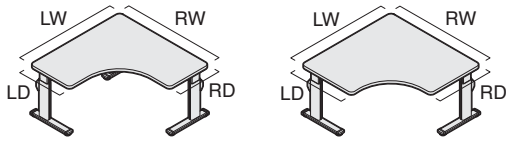

Specifying  
▶ Page 304

---

### 90° Equal Worksurfaces

# Slatwall

## Freestanding Slatwall Stanchions

For Use on Worksurfaces 3/4" to 2" thick

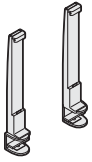

*Tip: Positions top of Slatwall a fixed height of 15 1/2" above mounting surface.*

*Tip: Slatwall can overhang stanchions up to 12"*

*Tip: Worksurface/table must be able to support 60 lb.*

*Tip: Stanchion cannot be used in a corner application or on a glass surface.*

*Tip: Requires 18"D worksurface and uses 2" surface footprint.*

*Tip: Freestanding Slatwall stanchion is for use with 12"H tiles only.*

Standard Includes	Required to Specify
<ul style="list-style-type: none"> <li>• Pair of Slatwall: paint</li> <li>• Non-marring rubber feet</li> </ul>	<ul style="list-style-type: none"> <li>1 Style number</li> <li>2 Paint color number for slatwall brackets:                             <ul style="list-style-type: none"> <li>0835 Black</li> <li>4750 Champagne</li> <li>4799 Platinum</li> </ul> </li> </ul>

Related Products
<ul style="list-style-type: none"> <li>• Slatwall tiles</li> </ul>

▶ Page 273

### Specification Information

• Dimensions			• Weight	• Style	• U.S.
D	W	H		Number	Price
3"	3 1/2"	16"	3.5 lb	<b>WFCS</b>	\$145

**Products on this page are Details, not turnstone.** They are included here to simplify your planning. Remember that Details has different pricing terms than turnstone products.

**For Canadian Pricing**  
 Multiply U.S. Price by the Canadian price factor.  
 ▶ See page 1 for details.

## Slatwall Tiles

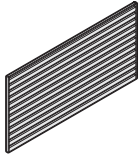

*Tip: Total dimensions of Worktools specified should not exceed Slatwall dimensions.*

*Tip: Slatwall is not dedicated to the exact panel width; a 12" overhang is acceptable.*

*Tip: Two Slatwall tiles cannot be used in a corner application.*

*Tip: Tiles require a minimum worksurface depth of 18" for stability.*

*Tip: A clearance of 2" is required under worksurface to accommodate C-clamp.*

*Tip: Tiles cannot be used on glass, bullnose, knife edge, or other non-standard work-surface edges.*

*Tip: Supports up to 60 lb.*

*Tip: Slatwall is 1/8" shorter than stated without end caps installed.*

Standard Includes	Required to Specify
-------------------	---------------------

- Slatwall tile: paint

- 1 Style number
- 2 Paint color number for slatwall tile:
  - 0835 Black
  - 4799 Platinum
  - 4750 Champagne

Related Products
------------------

- Slatwall brackets
- Freestanding Slatwall stanchions
- Slatwall and SlatRail worktools

- ▶ Page 274
- ▶ Page 272
- ▶ Pages 278-282

Specification Information						
• Dimensions			• Weight	• Style	• U.S.	
D	W	H		Number	Price	

### 12"H Tiles

1/2"	24"	12"	1 lb	<b>WS24</b>	\$116	
1/2"	30"	12"	1 lb	<b>WS30</b>	\$130	
1/2"	36"	12"	1 lb	<b>WS36</b>	\$145	
1/2"	42"	12"	1 lb	<b>WS42</b>	\$169	
1/2"	45"	12"	1 lb	<b>WS45</b>	\$180	
1/2"	48"	12"	1 lb	<b>WS48</b>	\$193	
1/2"	60"	12"	1 lb	<b>WS60</b>	\$241	
:	:	:	:	:	:	

**Products on this page are Details, not turnstone.** They are included here to simplify your planning. Remember that Details has different pricing terms than turnstone products.



**For Canadian Pricing**  
 Multiply U.S. Price by the Canadian price factor.  
 ▶ See page 1 for details.

**Slatwall Brackets**

*Tip: Wall-mount brackets must be mounted to a wall stud.*

*Tip: Brackets for use with 42"H panels cannot be used with transaction top worksurfaces.*

*Tip: Allow for 5 1/4" clearance on each end of the worksurface when mounting on c:scape desks.*

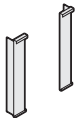
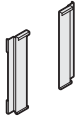

Standard Includes	Required to Specify
-------------------	---------------------

- Pair of slatwall brackets: paint

- 1 Style number
- 2 Paint color number for slatwall brackets:
  - 0835 Black
  - 4750 Champagne
  - 4799 Platinum

Related Products
------------------

- Slatwall tiles

▶ Page 273

Specification Information				
---------------------------	--	--	--	--

• Dimensions	• Weight	• Style	• U.S.	
W    H	:	Number	Price	

**12"H Panel-Mount Brackets**

**For Use with Answer and Kick**

2"	12 1/3"	2 lb	<b>WSWANS</b>	\$37
----	---------	------	---------------	------

**For Use with Avenir and Series 9000**

2"	12 1/3"	2 lb	<b>WSWUSA</b>	\$37
----	---------	------	---------------	------

**For Use with Answer and Kick 42"H Panels**

2"	12 1/3"	2 lb	<b>WSW42AN</b>	\$72
:	:	:	:	:

**Wall-Mount Brackets**

**12"H Standard**

2"	12 1/3"	2 lb	<b>WSWM</b>	\$37
:	:	:	:	:

**Products on this page are Details, not turnstone.** They are included here to simplify your planning. Remember that Details has different pricing terms than turnstone products.



**For Canadian Pricing**  
 Multiply U.S. Price by the Canadian price factor.  
 ▶ See page 1 for details.

## Freestanding SlatRail Stanchions

For Use on Worksurfaces and Materials 1/2" to 1 3/4" thick

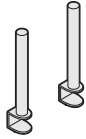

*Tip: Positions top of SlatRail a fixed height of 12 3/4" above mounting surface.*

*Tip: Worksurface/table must be able to support 100 lb.*

*Tip: Stanchion cannot be used in a corner application or on a glass surface.*

*Tip: Requires 18"D worksurface and uses 2 1/2" surface footprint.*

*Tip: A clearance of 2" is required under worksurface to accommodate C-clamp.*

*Tip: Actual width of usable SlatRail is 3 1/8" less than stated when installed using freestanding stanchions.*

Standard Includes	Required to Specify
-------------------	---------------------

- Pair of SlatRail stanchions: paint

- 1 Style number
- 2 Paint color number for SlatRail Stanchions:
  - 0835 Black
  - 4750 Champagne
  - 4799 Platinum

Related Products
------------------

- SlatRail

▶ Page 276

Specification Information					
• Dimensions			• Weight	• Style	• U.S.
D	W	H		Number	Price

1 1/2"	1 1/2"	13 1/2"	4 lb	<b>WSRFS</b>	\$127
:	:	:	:	:	:

**Products on this page are Details, not turnstone.**

They are included here to simplify your planning. Remember that Details has different pricing terms than turnstone products.



**For Canadian Pricing**

Multiply U.S. Price by the Canadian price factor.

▶ See page 1 for details.

# SlatRail

## SlatRail

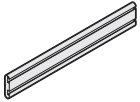

*Tip: When mounting SlatRail with stanchions in combination with a cableway, see Worktools Compatibility Charts, in the Details Specification Guide.*

*Tip: To determine appropriate SlatRail with stanchions width when mounting to Height-Adjustable worksurfaces, see Worktools Compatibility Charts, in the Details Specification Guide.*

*Tip: SlatRail requires a minimum worksurface depth of 18" for stability.*

*Tip: Total dimensions of Worktools specified should not exceed SlatRail dimensions.*

*Tip: Two SlatRails cannot be used in a corner application.*

*Tip: Not applicable on glass surfaces.*

*Tip: Actual width of usable SlatRail is 3 1/8" less than stated when installed using freestanding stanchions.*

*Tip: Supports up to 100 lb.*

Standard Includes	Required to Specify
<ul style="list-style-type: none"> <li>SlatRail: paint</li> </ul>	<ol style="list-style-type: none"> <li>Style number</li> <li>Paint color number for SlatRail:                             <ul style="list-style-type: none"> <li>0835 Black</li> <li>4750 Champagne</li> <li>4799 Platinum</li> </ul> </li> </ol>

Related Products	
<ul style="list-style-type: none"> <li>Freestanding SlatRail stanchions</li> <li>SlatRail panel-mount brackets</li> <li>SlatRail wall-mount brackets</li> <li>Slatwall and SlatRail worktools</li> </ul>	<ul style="list-style-type: none"> <li>▶ Page 275</li> <li>▶ Page 277</li> <li>▶ Page 277</li> <li>▶ Pages 278-282</li> </ul>

Specification Information					
• Dimensions			• Weight	• Style	• U.S.
D	W	H		Number	Price
3/4"	24"	4"	2 lb	<b>WSR24</b>	\$ 68
3/4"	30"	4"	3 lb	<b>WSR30</b>	\$ 81
3/4"	36"	4"	3 lb	<b>WSR36</b>	\$ 93
3/4"	42"	4"	3.5 lb	<b>WSR42</b>	\$106
3/4"	48"	4"	4 lb	<b>WSR48</b>	\$118
3/4"	60"	4"	4.5 lb	<b>WSR60</b>	\$144

**Products on this page are Details, not turnstone.** They are included here to simplify your planning. Remember that Details has different pricing terms than turnstone products.



**For Canadian Pricing**  
 Multiply U.S. Price by the Canadian price factor.  
 ▶ See page 1 for details.

## SlatRail Panel-Mount Brackets



Tip: Answer, Avenir, Kick, Privacy Wall, and Series 9000 furniture systems accommodate the SlatRail panel-mount brackets.

Standard Includes	Required to Specify
-------------------	---------------------

- |  |              |
|--|--------------|
| <ul style="list-style-type: none"> <li>• Pair of SlatRail panel-mount brackets: 4799 Platinum</li> </ul> | Style number |
|--|--------------|

Related Products
------------------

- |  |            |
|--|------------|
| <ul style="list-style-type: none"> <li>• SlatRail</li> </ul> | ▶ Page 276 |
|--|------------|

Specification Information				
---------------------------	--	--	--	--

• Dimensions		• Weight	• Style Number	• U.S. Price
W	H			
2½"	4½"	1.5 lb	<b>WSRU1</b>	\$39
·	·	·	·	·

## SlatRail Wall-Mount Brackets



Tip: Wall-mount brackets must be installed in a wall stud.

Standard Includes	Required to Specify
-------------------	---------------------

- |   |              |
|---|--------------|
| <ul style="list-style-type: none"> <li>• Pair of SlatRail wall-mount brackets: 4799 Platinum</li> </ul> | Style number |
|---|--------------|

Related Products
------------------

- |  |            |
|--|------------|
| <ul style="list-style-type: none"> <li>• SlatRail</li> </ul> | ▶ Page 276 |
|--|------------|

Specification Information					
---------------------------	--	--	--	--	--

• Dimensions			• Weight	• Style Number	• U.S. Price
D	W	H			
2¾"	¾"	4¾"	1.5 lb	<b>WSRW</b>	\$39
·	·	·	·	·	·

**Products on this page are Details, not turnstone.** They are included here to simplify your planning. Remember that Details has different pricing terms than turnstone products.



**For Canadian Pricing**  
 Multiply U.S. Price by the Canadian price factor.  
 ▶ See page 1 for details.

# Slatwall, SlatRail, and Freestanding Worktools

## Letter Tray

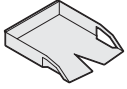

Tip: Trays do not interlock when installed on slatwall.

Standard Includes	Required to Specify
<ul style="list-style-type: none"> <li>• Tray: plastic</li> </ul>	<ul style="list-style-type: none"> <li>1 Style number</li> <li>2 Plastic color number for letter tray:                             <ul style="list-style-type: none"> <li>6000 Black</li> <li>6009 Arctic White</li> <li>6544 Frost</li> <li>6545 Amber</li> <li>6546 Rain</li> </ul> </li> </ul>

Related Products	
<ul style="list-style-type: none"> <li>• Slatwall tiles</li> <li>• SlatRail</li> </ul>	<ul style="list-style-type: none"> <li>▶ Page 273</li> <li>▶ Page 276</li> </ul>

Specification Information					
• Dimensions			• Weight	• Style	• U.S.
D	W	H		Number	Price
12½"	10¾"	2½"	1.5 lb	<b>WLTS</b>	\$37

## Binder Holder

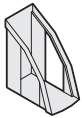

Tip: Binder holder requires 9½"H clearance under bins or shelves.

Standard Includes	Required to Specify
<ul style="list-style-type: none"> <li>• Binder holder: plastic</li> </ul>	<ul style="list-style-type: none"> <li>1 Style number</li> <li>2 Plastic color number for binder holder:                             <ul style="list-style-type: none"> <li>6000 Black</li> <li>6009 Arctic White</li> <li>6544 Frost</li> <li>6545 Amber</li> <li>6546 Rain</li> </ul> </li> </ul>

Related Products	
<ul style="list-style-type: none"> <li>• Slatwall tiles</li> <li>• SlatRail</li> </ul>	<ul style="list-style-type: none"> <li>▶ Page 273</li> <li>▶ Page 276</li> </ul>

Specification Information					
• Dimensions			• Weight	• Style	• U.S.
D	W	H		Number	Price
9⅛"	4¾"	11⅜"	1.2 lb	<b>WBHS</b>	\$37

**Products on this page are Details, not turnstone.** They are included here to simplify your planning. Remember that Details has different pricing terms than turnstone products.



**For Canadian Pricing**  
 Multiply U.S. Price by the Canadian price factor.  
 ▶ See page 1 for details.

## Hanging Brackets

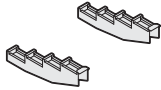

Tip: Hanging brackets not recommended for use on stanchion-mounted SlatRail or c:scape brackets mounted on SlatRail.

Tip: Hanging brackets require 6" clearance from top step of bracket to access files under bin and a 9" clearance from the bottom step to the top of worksurface to allow files to hang freely.

Tip: Hanging brackets are recommended using in pairs only. Brackets should not be shared when mounting multiple brackets side by side.

Standard Includes	Required to Specify
-------------------	---------------------

- Hanging brackets: plastic

- 1 Style number
- 2 Plastic color number for hanging brackets:
  - 6000 Black
  - 6009 Arctic White
  - 6544 Frost
  - 6545 Amber
  - 6546 Rain

Related Products
------------------

- Slatwall tiles
- SlatRail

- ▶ Page 273
- ▶ Page 276

Specification Information					
• Dimensions			• Weight	• Style	• U.S.
D	W	H		Number	Price

93/4"	1 1/2"	1 1/4"	1 lb	<b>WHB</b>	\$37
:	:	:	:	:	:

## Pen/Pencil Cup



Standard Includes	Required to Specify
-------------------	---------------------

- Pen/pencil cup: plastic

- 1 Style number
- 2 Plastic color number for pen/pencil cup:
  - 6000 Black
  - 6009 Arctic White
  - 6544 Frost
  - 6545 Amber
  - 6546 Rain

Related Products
------------------

- Slatwall tiles
- SlatRail

- ▶ Page 273
- ▶ Page 276

Specification Information					
• Dimensions			• Weight	• Style	• U.S.
D	W	H		Number	Price

4"	3 1/4"	3 5/8"	0.5 lb	<b>WPCS</b>	\$37
:	:	:	:	:	:

**Products on this page are Details, not turnstone.** They are included here to simplify your planning. Remember that Details has different pricing terms than turnstone products.



**For Canadian Pricing**  
 Multiply U.S. Price by the Canadian price factor.  
 ▶ See page 1 for details.

Slatwall, SlatRail, and Freestanding Worktools, continued

**Double Square Dish**



**Standard Includes** **Required to Specify**

- Double square dish: plastic
- Attachment bracket

- 1 Style number
- 2 Plastic color number for square dish:
  - 6000 Black
  - 6009 Arctic White
  - 6544 Frost
  - 6545 Amber
  - 6546 Rain

**Related Products**

- Slatwall tiles ▶ Page 273
- SlatRail ▶ Page 276

**Specification Information**

• Dimensions			• Weight	• Style	• U.S.
D	W	H		Number	Price
4"	9¾"	1½"	0.5 lb	<b>WSQS</b>	\$37

**Personal Shelf**

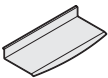

**Standard Includes** **Required to Specify**

- Personal shelf: paint

- 1 Style number
- 2 Paint color number for personal shelf:
  - 0835 Black
  - 4750 Champagne
  - 7018 Pewter

**Related Products**

- Slatwall tiles ▶ Page 273
- SlatRail ▶ Page 276

**Specification Information**

• Dimensions		• Weight	• Style	• U.S.
D	W		Number	Price
7⅛"	13½"	3 lb	<b>WSPS</b>	\$42

**Products on this page are Details, not turnstone.** They are included here to simplify your planning. Remember that Details has different pricing terms than turnstone products.



**For Canadian Pricing**  
 Multiply U.S. Price by the Canadian price factor.  
 ▶ See page 1 for details.

## Telephone Caddy



Tip: Telephone caddy is not compatible with Cisco phones.

Standard Includes	Required to Specify
<ul style="list-style-type: none"> <li>Telephone caddy: paint</li> </ul>	1 Style number 2 Paint color number for telephone caddy: 0835 Black 4750 Champagne 7018 Pewter

Related Products
<ul style="list-style-type: none"> <li>Slatwall tiles</li> <li>SlatRail</li> </ul>

Specification Information					
Dimensions			Weight	Style Number	U.S. Price
D	W	H			
2"	8"	11"	6 lb	<b>WTCS</b>	\$91

## Utility Hook



Standard Includes	Required to Specify
<ul style="list-style-type: none"> <li>Utility hook: paint</li> </ul>	1 Style number 2 Paint color number for utility hook: 0835 Black 4750 Champagne 7018 Pewter

Specification Information					
Dimensions			Weight	Style Number	U.S. Price
D	W	H			
1 3/4"	3 1/2"	2"	0.25 lb	<b>WHOOK</b>	\$37

**Products on this page are Details, not turnstone.** They are included here to simplify your planning. Remember that Details has different pricing terms than turnstone products.



**For Canadian Pricing**  
 Multiply U.S. Price by the Canadian price factor.  
 ▶ See page 1 for details.

**Details**

Slatwall, SlatRail, and Freestanding Worktools, continued

**Flat Top Hanger**

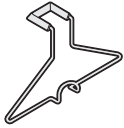

Standard Includes	Required to Specify
<ul style="list-style-type: none"><li>• Hanger: paint</li><li>• Rubber sleeve</li></ul>	<ul style="list-style-type: none"><li>1 Style number</li><li>2 Paint color number for hanger:<ul style="list-style-type: none"><li>0835 Black</li><li>4750 Champagne</li></ul></li></ul>

**Specification Information**

• Dimensions			• Weight	• Style	• U.S.
D	W	H		Number	Price
3"	15½"	7¾"	1 lb	<b>FTH</b>	\$22

**Products on this page are Details, not turnstone.** They are included here to simplify your planning. Remember that Details has different pricing terms than turnstone products.

 **For Canadian Pricing**  
Multiply U.S. Price by the Canadian price factor.  
▶ See page 1 for details.

## SOTO Rails

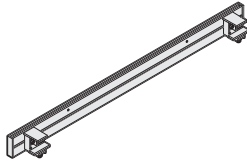

*Tip: Rails clamp to free-standing worksurfaces or material up to 2" thick. Rails are not applicable for glass surfaces.*

*Tip: Not applicable on glass surfaces.*

*Tip: Allow 1" clearance between worksurface and rail for cable management. Allow 2" for rail mount installed behind a worksurface, and 3¾" overall to install the rail.*

*Tip: Maximum weight load for rails is 2 lb per lineal inch.*

*Tip: Each clamp requires a 2" footprint above the worksurface, and a 3¼" clearance below the worksurface.*

*Tip: Rails require a minimum worksurface depth of 18" for stability.*

Standard Includes	Required to Specify
-------------------	---------------------

- Rail: 4799 Platinum

Style number

Related Products
------------------

- SOTO worktools
- SOTO shelves

- ▶ Pages 283-290
- ▶ Page 286

Specification Information					
Dimensions			Weight	Style Number	U.S. Price
D	W	H			

Dimensions			Weight	Style Number	U.S. Price
D	W	H			
1"	28"	3¼"	4.6 lb	<b>DSR28</b>	\$197
1"	34"	3¼"	5.2 lb	<b>DSR34</b>	\$208
1"	40"	3¼"	5.75 lb	<b>DSR40</b>	\$220
1"	46"	3¼"	6.3 lb	<b>DSR46</b>	\$233
1"	52"	3¼"	6.9 lb	<b>DSR52</b>	\$245
1"	58"	3¼"	7.5 lb	<b>DSR58</b>	\$257
1"	64"	3¼"	8 lb	<b>DSR64</b>	\$270

**Products on this page are Details, not turnstone.** They are included here to simplify your planning. Remember that Details has different pricing terms than turnstone products.



**For Canadian Pricing**  
 Multiply U.S. Price by the Canadian price factor.  
 ▶ See page 1 for details.

**SOTO Rails for use with Tour**



*Tip: Allow 1" clearance between worksurface and rail for cable management. Allow 2" for rail mount installed behind a worksurface, and 3/4" overall to install the rail.*

*Tip: Maximum weight load for rails is 2 lb per lineal inch.*

*Tip: Each clamp requires a 2" footprint above the worksurface, and a 3/4" clearance below the worksurface.*

*Tip: Tour rails clamp to Tour bench troughs. Rails are not applicable for glass surfaces.*

*Tip: Rails require a minimum worksurface depth of 18" for stability.*

**Standard Includes** **Required to Specify**

- Rail: 4799 Platinum

Style number

**Related Products**

- SOTO worktools
- SOTO shelves

- ▶ Page 283
- ▶ Page 286

**Specification Information**

Corresponding Table Top Width	Dimensions			Weight	Style Number	U.S. Price
	D	W	H			
60"	1"	52"	3/4"	6.9 lb	<b>DSRT52</b>	\$245
66"	1"	58"	3/4"	7.5 lb	<b>DSRT58</b>	\$257
72"	1"	64"	3/4"	8 lb	<b>DSRT64</b>	\$270

**Products on this page are Details, not turnstone.** They are included here to simplify your planning. Remember that Details has different pricing terms than turnstone products.



**For Canadian Pricing**  
 Multiply U.S. Price by the Canadian price factor.  
 ▶ See page 1 for details.

### SOTO Cableways

Tip: Cableway hangs fixed at 8" below the worksurface.

#### Standard Includes

- Cableway: 4799 Platinum

#### Required to Specify

Style number

#### Related Products

- SOTO worktools
- SOTO shelves

- ▶ Pages 283-290
- ▶ Page 286

#### Specification Information

Dimensions			Weight	Style Number	U.S. Price
D	W	H			
2 1/2"	20"	8"	2 lb	<b>DSCW20</b>	\$145
2 1/2"	30"	8"	2.5 lb	<b>DSCW30</b>	\$163

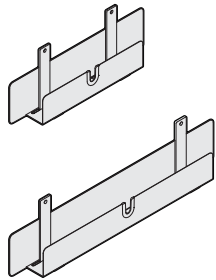

Worktools

**Products on this page are Details, not turnstone.** They are included here to simplify your planning. Remember that Details has different pricing terms than turnstone products.

 **For Canadian Pricing**  
 Multiply U.S. Price by the Canadian price factor.  
 ▶ See page 1 for details.

**SOTO Shelves**

*Tip: All SOTO shelves allow for 2 7/8" or 6" between work-surface and bottom of shelf.*

Standard Includes	Required to Specify
<ul style="list-style-type: none"> <li>• Shelf: paint</li> <li>• Stanchions: 4799 Platinum</li> </ul>	<ul style="list-style-type: none"> <li>1 Style number</li> <li>2 Paint color number for shelf: 4231 Arctic White 4799 Platinum</li> </ul>

**Specification Information**

Dimensions			Weight	Style Number	U.S. Price
D	W	H			

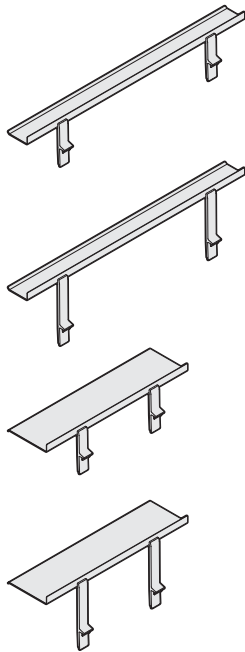

**36\"/>**

3 1/2"	36"	6 9/10"	3.9 lb	<b>DSSA363</b>	\$144
--------	-----	---------	--------	----------------	-------

**36\"/>**

3 1/2"	36"	10"	4.2 lb	<b>DSSA363H</b>	\$149
--------	-----	-----	--------	-----------------	-------

**24\"/>**

6 3/4"	24"	6 9/10"	4.9 lb	<b>DSSA246</b>	\$149
--------	-----	---------	--------	----------------	-------

10 1/4"	24"	6 9/10"	6.4 lb	<b>DSSA2410</b>	\$159
---------	-----	---------	--------	-----------------	-------

**24\"/>**

6 3/4"	24"	10"	5.3 lb	<b>DSSA246H</b>	\$154
--------	-----	-----	--------	-----------------	-------

10 1/4"	24"	10"	6.7 lb	<b>DSSA2410H</b>	\$164
---------	-----	-----	--------	------------------	-------

► **Specification Information, continued on next page**

**Products on this page are Details, not turnstone.** They are included here to simplify your planning. Remember that Details has different pricing terms than turnstone products.



**For Canadian Pricing**  
 Multiply U.S. Price by the Canadian price factor.  
 ► See page 1 for details.

► Specification Information, continued from previous page

**Specification Information**

Dimensions			Weight	Style Number	U.S. Price
D	W	H			

**14"W Standard Shelves**

3½"	14"	6¾"	2.2 lb	<b>DSSA143</b>	\$138
6¾"	14"	6¾"	3.6 lb	<b>DSSA146</b>	\$144
10¼"	14"	6¾"	4.4 lb	<b>DSSA1410</b>	\$154

**14"W High Shelves**

3½"	14"	10"	2.5 lb	<b>DSSA143H</b>	\$144
6¾"	14"	10"	3.9 lb	<b>DSSA146H</b>	\$149
10¼"	14"	10"	4.7 lb	<b>DSSA1410H</b>	\$159

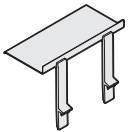
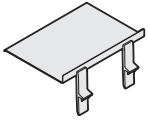

**Products on this page are Details, not turnstone.** They are included here to simplify your planning. Remember that Details has different pricing terms than turnstone products.



**For Canadian Pricing**  
 Multiply U.S. Price by the Canadian price factor.  
 ► See page 1 for details.

SOTO Worktools, continued

**SOTO Pile Box**

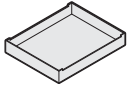

Standard Includes	Required to Specify
<ul style="list-style-type: none"> <li>• Pile box: 6009 Arctic White plastic</li> </ul>	Style number

**Specification Information**

• Dimensions			• Weight	• Style	• U.S.
D	W	H		Number	Price
97/8"	121/4"	2"	0.7 lb	<b>DSSPB</b>	\$38

**SOTO Landscape Letter Box**

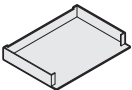

Standard Includes	Required to Specify
<ul style="list-style-type: none"> <li>• Landscape letter box: 6009 Arctic White plastic</li> </ul>	Style number

**Specification Information**

• Dimensions			• Weight	• Style	• U.S.
D	W	H		Number	Price
97/8"	133/4"	2"	0.8 lb	<b>DSLLB</b>	\$38

**SOTO Tool Box**



*Tip: Tool box contains removable semi-opaque insert to separate pens from sticky notes.*

Standard Includes	Required to Specify
<ul style="list-style-type: none"> <li>• Tool box: 6009 Arctic White plastic</li> </ul>	Style number

**Specification Information**

• Dimensions			• Weight	• Style	• U.S.
D	W	H		Number	Price
31/2"	31/4"	31/2"	0.3 lb	<b>DSTB</b>	\$33

**Products on this page are Details, not turnstone.** They are included here to simplify your planning. Remember that Details has different pricing terms than turnstone products.

**For Canadian Pricing**  
 Multiply U.S. Price by the Canadian price factor.  
 ▶ See page 1 for details.

### SOTO Diagonal File Box

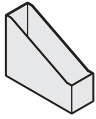

Standard Includes	Required to Specify
• Diagonal file box: 6009 Arctic White plastic	Style number

Specification Information					
• Dimensions			• Weight	• Style	• U.S.
D	W	H		Number	Price
12¼"	4"	9⅞"	0.5 lb	<b>DSDFB</b>	\$38
:	:	:	:	:	:

### SOTO Utility Box



Standard Includes	Required to Specify
• Utility box: 6009 Arctic White plastic	Style number

Specification Information					
• Dimensions			• Weight	• Style	• U.S.
D	W	H		Number	Price
3⅞"	9"	1¼"	0.3 lb	<b>DSUB</b>	\$33
:	:	:	:	:	:

**Products on this page are Details, not turnstone.** They are included here to simplify your planning. Remember that Details has different pricing terms than turnstone products.



**For Canadian Pricing**  
 Multiply U.S. Price by the Canadian price factor.  
 ▶ See page 1 for details.

**Details**

SOTO Worktools, continued

**SOTO Personal Box**

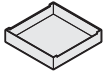

Standard Includes	Required to Specify
<ul style="list-style-type: none"> <li>Personal box: 6009 Arctic White plastic</li> </ul>	Style number

Specification Information					
• Dimensions			• Weight	• Style	• U.S.
D	W	H		Number	Price
9"	9"	2"	0.3 lb	<b>DSPB</b>	\$33

**SOTO Storage Boxes, Set of Three**

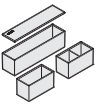

*Tip: The storage box set fits inside the personal box.*

- Tip: The box dimensions are:*
- Open rectangle box with or without divider 2<sup>1</sup>/<sub>8</sub>"D x 4<sup>1</sup>/<sub>4</sub>"W x 2<sup>3</sup>/<sub>8</sub>"H
  - Long rectangle box with lid 2<sup>1</sup>/<sub>8</sub>"D x 8<sup>5</sup>/<sub>8</sub>"W x 2<sup>3</sup>/<sub>8</sub>"H

Standard Includes	Required to Specify
<ul style="list-style-type: none"> <li>Set of three storage boxes: semi-opaque boxes with white cover</li> </ul>	Style number

Specification Information		
• Style	• Weight	• U.S.
Number		Price
<b>DSSB</b>	0.4 lb	\$38

**Products on this page are Details, not turnstone.** They are included here to simplify your planning. Remember that Details has different pricing terms than turnstone products.



**For Canadian Pricing**  
 Multiply U.S. Price by the Canadian price factor.  
 ▶ See page 1 for details.

## SOTO LED Lights

*Tip: Rail-mounted bracket of SOTO LED may occupy the same space as a SOTO 3", 6", and 10" shelf extending over the shelf itself.*

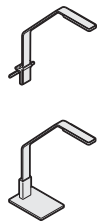

Standard Includes	Required to Specify
-------------------	---------------------

- Task light and mounting bracket: paint
- 4-watt LED 3500K
- 9' low voltage modular cord: black plastic only

- 1 Style number
- 2 Paint color number for light:
  - 4231 Arctic White
  - 4710 Low Gloss Black
  - 4799 Platinum

Specification Information					
• Dimensions			• Weight	• Style	• U.S.
D	W	H		Number	Price

### Rail-Mounted

12¾"	1½"	14¼"	0.6 lb	<b>DSLEDR</b>	\$295
------	-----	------	--------	---------------	-------

### Freestanding

12¾"	4¼"	14¾"	2.2 lb	<b>DSLEDF</b>	\$321
------	-----	------	--------	---------------	-------

## Mini SOTO LED Light



Standard Includes	Required to Specify
-------------------	---------------------

- Task light and mounting bracket: 4799 Platinum
- 4-watt LED 3500K
- 9' low voltage modular cord: black plastic only

- Style number

Specification Information					
• Dimensions			• Weight	• Style	• U.S.
D	W	H		Number	Price

1¾"	7"	5/8"	0.3 lb	<b>LMINILED</b>	\$236
-----	----	------	--------	-----------------	-------

**Products on this page are Details, not turnstone.** They are included here to simplify your planning. Remember that Details has different pricing terms than turnstone products.



**For Canadian Pricing**  
 Multiply U.S. Price by the Canadian price factor.  
 ▶ See page 1 for details.

# Keyboard Assemblies

## Stella Keyboard Assemblies

*Tip: Jules platform can be used in 12" radius corners when used with an extended mechanism.*

*Tip: Be sure to consider the mechanism track length in relationship to the work surface depth.*

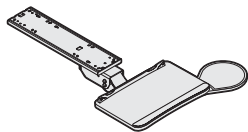
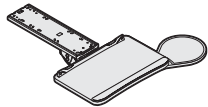
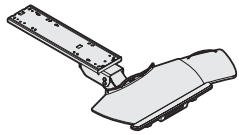
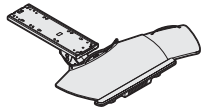

Standard Includes	Required to Specify
<ul style="list-style-type: none"> <li>• Mechanism and track: 0835 Black</li> <li>• Keyboard platform:                             <ul style="list-style-type: none"> <li>– Slider: 7027 Charcoal paint</li> <li>– Jules: 6288 Charcoal plastic</li> </ul> </li> <li>• Mouse surface:                             <ul style="list-style-type: none"> <li>– Slider and Jules: ambidextrous, sliding mouse surface</li> </ul> </li> <li>• Palm rest</li> </ul>	Style number

Specification Information				
Dimensions			Style	U.S.
D	W	H	Number	Price

### Slider Platforms

#### With 20" L Track

9 1/2"	20"	3"	<b>SS20SL10SA</b>	\$516
--------	-----	----	-------------------	-------

#### With 23" L Track

9 1/2"	20"	3"	<b>SE23SL10SA</b>	\$533
--------	-----	----	-------------------	-------

### Jules Platforms

#### With 20" L Track

12"	18 3/4"	5 5/8"	<b>SS20JP10SF</b>	\$412
-----	---------	--------	-------------------	-------

#### With 23" L Track

12"	18 3/4"	5 5/8"	<b>SE23JP10SF</b>	\$429
-----	---------	--------	-------------------	-------

**Products on this page are Details, not turnstone.** They are included here to simplify your planning. Remember that Details has different pricing terms than turnstone products.



**For Canadian Pricing**  
 Multiply U.S. Price by the Canadian price factor.  
 ▶ See page 1 for details.



**Lift and Lock Keyboard Assemblies**

*Tip: Be sure to consider the mechanism track length in relationship to the work surface depth.*

Standard Includes	Required to Specify
<ul style="list-style-type: none"> <li>• Mechanism and track: 0835 Black</li> <li>• Keyboard platform:                             <ul style="list-style-type: none"> <li>– 19", 26", and Enviro: 7207 Charcoal paint</li> </ul> </li> <li>• Mouse surface:                             <ul style="list-style-type: none"> <li>– 19" and Enviro: 9" diameter same-plane, swivel mouse surface</li> </ul> </li> <li>• Palm rest: Green Gel</li> </ul>	<ul style="list-style-type: none"> <li>1 Style number</li> <li>2 Palm rest type (see below under Required Selections)</li> </ul>

Required Selections	U.S. Price	Required to Specify
<b>Palm Rest Type</b> <ul style="list-style-type: none"> <li>• Non-antimicrobial</li> <li>• Antimicrobial</li> </ul>	<ul style="list-style-type: none"> <li>No cost</li> <li>No cost</li> </ul>	<ul style="list-style-type: none"> <li>Specify with <i>non-antimicrobial</i>.</li> <li>Specify with <i>antimicrobial</i>.</li> </ul>

Specification Information					
Dimensions			Style	U.S.	
D	W	H	Number	Price	
:	:	:	:	:	
:	:	:	:	:	

**19" Platforms with 5" Arm and 23"L Track**

**Left-Handed**

9 <sup>3</sup> / <sub>4</sub> "	19"	3"	<b>L52319MLGG</b>	\$302
---------------------------------	-----	----	-------------------	-------

**Right-Handed**

9 <sup>3</sup> / <sub>4</sub> "	19"	3"	<b>L52319MRGG</b>	\$302
---------------------------------	-----	----	-------------------	-------

**19" Platforms with 7" Arm and 26"L Track**

**Left-Handed**

9 <sup>3</sup> / <sub>4</sub> "	19"	3"	<b>L72619MLGG</b>	\$302
---------------------------------	-----	----	-------------------	-------

**Right-Handed**

9 <sup>3</sup> / <sub>4</sub> "	19"	3"	<b>L72619MRGG</b>	\$302
---------------------------------	-----	----	-------------------	-------

► **Specification Information, continued on next page**

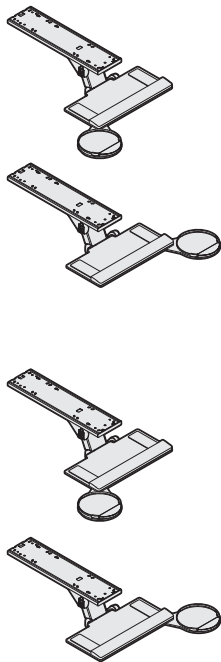

**For Canadian Pricing**  
 Multiply U.S. Price by the Canadian price factor.  
 ► See page 1 for details.

► Specification Information, continued from previous page

**Specification Information**

Dimensions			Style Number	U.S. Price
D	W	H		

**Enviro Platforms**

**With 5" Arm and 23" L Track**

14 1/2"	28"	3"	<b>L523EN10GG</b>	\$302
---------	-----	----	-------------------	-------

**With 7" Arm and 26" L Track**

14 1/2"	28"	3"	<b>L726EN10GG</b>	\$302
---------	-----	----	-------------------	-------

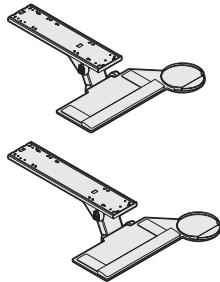

Worktools

**Products on this page are Details, not turnstone.** They are included here to simplify your planning. Remember that Details has different pricing terms than turnstone products.



**For Canadian Pricing**  
 Multiply U.S. Price by the Canadian price factor.  
 ► See page 1 for details.

# Technology Worktools and Cable Management

## Freestanding In-Line Document Support

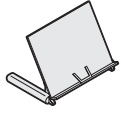

Standard Includes	Required to Specify
<ul style="list-style-type: none"> <li>Freestanding in-line document support: 6000 Black</li> </ul>	Style number

### Specification Information

• Dimensions			• Style Number	• U.S. Price
D	W	H		
18"	14"	12"	<b>CDFIS14</b>	\$117

## Adjustable Foot Rest

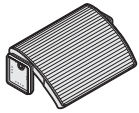

Standard Includes	Required to Specify
<ul style="list-style-type: none"> <li>Adjustable foot rest: 6000 Black plastic</li> </ul>	Style number

### Specification Information

• Dimensions			• Style Number	• U.S. Price
D	W	H		
12"	18"	2"-6"	<b>CFTR</b>	\$129

## Vertical Non-Locking CPU Cradle

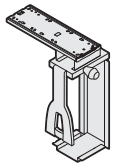

*Tip: Vertical CPU cradle supports CPUs 3½"W to 9"W, 15"D to 22"D, 12½"H to 22½"H and up to 85 lb.*

*Tip: CPU cradle requires 18" clearance under the worksurface.*

Standard Includes	Required to Specify
<ul style="list-style-type: none"> <li>CPU cradle: 0835 Black</li> <li>Soft touch knob for side clamp adjustment</li> <li>17"L track</li> </ul>	Style number

### Specification Information

• Dimensions			• Style Number	• U.S. Price
D	W	H		
17"	3½"	18¼"	<b>CPRCCN</b>	\$178



**For Canadian Pricing**  
 Multiply U.S. Price by the Canadian price factor.  
 ▶ See page 1 for details.

## Vertical Processor Sling

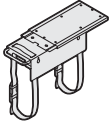

Tip: CPU must be at least 10"D and 3½"W for both standard and fixed vertical processor slings.

Tip: Standard vertical processor sling supports CPUs with perimeters of 53" and 75 lb.

Tip: Standard vertical processor requires 18" clearance under the worksurface.

Standard Includes	Required to Specify
-------------------	---------------------

- Vertical processor sling: 0835 Black
- 17"L track for standard vertical processor sling, if selected

Style number

Specification Information					
• Dimensions			• Style	• U.S.	
D	W	H	Number	Price	

18"	5½"	2½"	<b>CPRSL</b>	\$146	
:	:	:	:	:	

## CPU Trolley

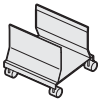

Tip: Trolley supports CPUs from 5¼"W to 8½"W and up to 85 lb.

Tip: CPU trolley requires a maximum 10"W floor clearance when fully expanded.

Standard Includes	Required to Specify
-------------------	---------------------

- CPU trolley that supports CPU vertically: 6029 Chalk
- Two locking and two non-locking casters

Style number

Specification Information					
• Dimensions			• Style	• U.S.	
D	W	H	Number	Price	

11"	10"	10"	<b>QACPUT</b>	\$109	
:	:	:	:	:	

**Products on this page are Details, not turnstone.** They are included here to simplify your planning. Remember that Details has different pricing terms than turnstone products.



**For Canadian Pricing**  
 Multiply U.S. Price by the Canadian price factor.  
 ▶ See page 1 for details.

# Flat Panel Monitor Arm Support Assemblies

## Eyesite Single Display Support

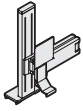

Tip: Eyesite single display support is for use with monitors up to 20 lb.

Tip: For large monitor screens (20"+), order standard columns. For small monitor screens (17"-19"), order extended columns.

▶ See turnstone Specification Guide

Tip: Bivi bracket to be used with Eyesite single support, dual display support, and dual laptop support with extended crank adjust columns only.

Standard Includes	Required to Specify
<ul style="list-style-type: none"> <li>• Monitor arm: 4799 Platinum</li> <li>• Mounting bracket: 4799 Platinum</li> </ul>	Style number

### Specification Information

• Dimensions			• Weight	• Style Number	• U.S. Price
D	W	H			
6 <sup>5</sup> / <sub>8</sub> "	11 <sup>5</sup> / <sub>8</sub> "	20"	10 lb	<b>FPAEC1BIVI</b>	\$486

### Bivi Mount

6 <sup>5</sup> / <sub>8</sub> "	11 <sup>5</sup> / <sub>8</sub> "	20"	10 lb	<b>FPAEC1BIVI</b>	\$486
---------------------------------	----------------------------------	-----	-------	-------------------	-------

## Eyesite Dual Display Support

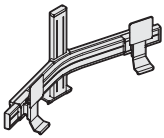

Tip: Eyesite dual display support is for use with two monitors up to 24" screens and 25 lb each.

Tip: For large monitor screens (20"+), order standard columns. For small monitor screens (17"-19"), order extended columns.

▶ See turnstone Specification Guide

Tip: Bivi bracket to be used with Eyesite single support, dual display support, and dual laptop support with extended crank adjust columns only.

Standard Includes	Required to Specify
<ul style="list-style-type: none"> <li>• Monitor arm: 4799 Platinum</li> <li>• Mounting bracket: 4799 Platinum</li> </ul>	1 Style number 2 Options, if selected (see below)

Options	U.S. Price	Required to Specify
<b>Bracket</b> <ul style="list-style-type: none"> <li>• Without pivot</li> <li>• With pivot</li> </ul>	No cost +\$18	Specify <i>without pivot</i> . Specify <i>with pivot</i> .

### Specification Information

• Dimensions			• Weight	• Style Number	• U.S. Base Price
D	W	H			
8 <sup>1</sup> / <sub>2</sub> "	31"	20"	17 lb	<b>FPAEC2BIVI</b>	\$763

### Bivi Mount

8 <sup>1</sup> / <sub>2</sub> "	31"	20"	17 lb	<b>FPAEC2BIVI</b>	\$763
---------------------------------	-----	-----	-------	-------------------	-------



**For Canadian Pricing**  
Multiply U.S. Price by the Canadian price factor.  
▶ See page 1 for details.

## Eyesite Single Laptop Support

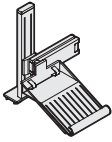

Tip: Eyesite flat panel monitor arms with laptop supports are not recommended for use with docking stations.

Tip: Bivi bracket to be used with Eyesite single support, dual display support, and dual laptop support with extended crank adjust columns only.

Standard Includes	Required to Specify
<ul style="list-style-type: none"> <li>• Monitor arm: 4799 Platinum</li> <li>• Laptop support and adjustment column: 4799 Platinum</li> <li>• Mounting bracket: 4799 Platinum</li> </ul>	Style number

### Specification Information

• Dimensions			• Weight	• Style	• U.S.
D	W	H		Number	Base Price
16"	11 <sup>5</sup> / <sub>8</sub> "	19 <sup>7</sup> / <sub>8</sub> "	12 lb	<b>FPAELC1BIVI</b>	\$513

### Bivi Mount

• Dimensions			• Weight	• Style	• U.S.
D	W	H		Number	Base Price
16"	11 <sup>5</sup> / <sub>8</sub> "	19 <sup>7</sup> / <sub>8</sub> "	12 lb	<b>FPAELC1BIVI</b>	\$513

## Eyesite Dual Laptop Support

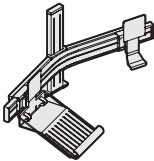

Tip: Eyesite dual laptop support is for use with monitor up to 24" screen and 25 lb.

Tip: Eyesite flat panel monitor arms with laptop supports are not recommended for use with docking stations.

Tip: Monitor cables that connect to the rear of the monitor near the VESA plate will not fit properly on the Eyesite monitor arm.

Tip: Bivi bracket to be used with Eyesite single support, dual display support, and dual laptop support with extended crank adjust columns only.

Standard Includes	Required to Specify
<ul style="list-style-type: none"> <li>• Monitor arm: 4799 Platinum</li> <li>• Laptop support and adjustment column: 4799 Platinum</li> <li>• Mounting bracket: 4799 Platinum</li> </ul>	1 Style number 2 Options, if selected (see below)

Options	U.S. Price	Required to Specify
<b>Bracket</b>		
• Without pivot	No cost	Specify <i>without pivot</i> .
• With pivot	+\$18	Specify <i>with pivot</i> .

### Specification Information

• Dimensions			• Weight	• Style	• U.S.
D	W	H		Number	Base Price
17"	31"	19 <sup>7</sup> / <sub>8</sub> "	19 lb	<b>FPAELC2BIVI</b>	\$813

### Bivi Mount

• Dimensions			• Weight	• Style	• U.S.
D	W	H		Number	Base Price
17"	31"	19 <sup>7</sup> / <sub>8</sub> "	19 lb	<b>FPAELC2BIVI</b>	\$813



**For Canadian Pricing**  
 Multiply U.S. Price by the Canadian price factor.  
 ▶ See page 1 for details.

Flat Panel Monitor Arm Support Assemblies, continued

**Eyesite Mounting Bracket**



Tip: Bivi bracket to be used with Eyesite single support, dual display support, and dual laptop support with extended crank adjust columns only.

Standard Includes	Required to Specify
• Bracket: 4799 Platinum	Style number

**Specification Information**

• Dimensions			• Weight	• Style Number	• U.S. Price
D	W	H			

**Bivi Bracket**

3"	4"	1/4"	1.5 lb	<b>FPCBIVI</b>	\$124
----	----	------	--------	----------------	-------

**CF Series Flat Panel Monitor Arms and Supports**

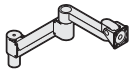

Tip: Mounting brackets must be ordered separately. ▶ See page 302

Tip: Standard arm supports monitors 10 to 20 lb.

Tip: When mounting CF Series arm brackets to Slatwall, bracket must be mounted no further than 10" away from Slatwall mounting bracket. If application does not allow bracket to be installed within the 10" range, an additional bracket or brackets should be installed within 10" of desired arm location.

Standard Includes	Required to Specify
-------------------	---------------------

- |  |  |
|--|--|
| <ul style="list-style-type: none"> <li>• Monitor arm: paint</li> <li>• Tilthead mechanism</li> </ul> | <ul style="list-style-type: none"> <li>1 Style number</li> <li>2 Paint color number for monitor arm:<br/>0835 Black<br/>7018 Pewter</li> <li>3 Tilthead mechanism (see below under Required Selections)</li> </ul> |
|--|--|

Required Selections	U.S. Price	Required to Specify
---------------------	------------	---------------------

<b>Tilthead Mechanism</b>	<ul style="list-style-type: none"> <li>• Standard tilthead No cost</li> <li>• Heavy duty spring tilthead +\$26</li> </ul>	Specify with <i>standard tilthead</i> . Specify with <i>heavy duty spring tilthead</i> .
---------------------------	---	---

**Specification Information**

• Weight	• Style Number	• U.S. Base Price
----------	----------------	-------------------

10.5 lb	<b>CF800</b>	\$431
---------	--------------	-------

**Products on this page are Details, not turnstone.** They are included here to simplify your planning. Remember that Details has different pricing terms than turnstone products.



**For Canadian Pricing**  
 Multiply U.S. Price by the Canadian price factor.  
 ▶ See page 1 for details.

## CF Series Flat Panel Monitor Pole Mounts

Tip: Mounting brackets must be ordered separately.  
▶ See page 302

Tip: Details announced a running change from 7027 Charcoal to 0835 Black on all CF Series monitor products. Charcoal will be available while supplies last for the following CF Series style numbers and related brackets and wall-mounts:

- CFSHA
- CFDHA



Tip: Single-arm pole mount supports monitors 5 to 35 lb.

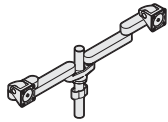

Tip: Double-arm pole mount supports monitors 5 to 35 lb and up to 19" screens.

Tip: Double-arm pole is not recommended for use with either Slatwall or SlatRail mounting brackets.

Standard Includes	Required to Specify
-------------------	---------------------

<ul style="list-style-type: none"> <li>• Monitor arm pole mount: paint</li> <li>• 12" pole</li> <li>• Tilthead mechanism</li> </ul>	<ul style="list-style-type: none"> <li>1 Style number</li> <li>2 Paint color number for monitor arm: 0835 Black, 7018 Pewter</li> <li>3 Tilthead mechanism (see below under Required Selections)</li> </ul>
---	---

Required Selections	U.S. Price	Required to Specify
---------------------	------------	---------------------

<b>Tilthead Mechanism</b> <ul style="list-style-type: none"> <li>• Standard tilthead</li> <li>• Heavy duty spring tilthead</li> </ul>	No cost +\$26	Specify with <i>standard tilthead</i> . Specify with <i>heavy duty spring tilthead</i> .
---	------------------	---

<b>Related Products</b> <ul style="list-style-type: none"> <li>• Flat panel monitor brackets</li> </ul>	▶ Page 302
---	------------

### Specification Information

Height	Weight	Style Number	U.S. Base Price
--------	--------	--------------	-----------------

#### Single-Arm Pole Mount

12"	6 lb	<b>CFSHA</b>	\$325
-----	------	--------------	-------

#### Double-Arm Pole Mount

12"	11.5 lb	<b>CFDHA</b>	\$555
-----	---------	--------------	-------

**Products on this page are Details, not turnstone.** They are included here to simplify your planning. Remember that Details has different pricing terms than turnstone products.



**For Canadian Pricing**  
Multiply U.S. Price by the Canadian price factor.  
▶ See page 1 for details.

**CF Series Flat Panel Monitor Brackets**

*Tip: Flat panel monitor arm must be used with flat panel monitor brackets, ordered separately.*

*Tip: Details announced a running change from 7027 Charcoal to 0835 Black on all CF Series monitor products. Charcoal will be available while supplies last for the following CF Series style numbers and related brackets and wall-mounts:*

- CFSHA
- CFDHA

*Tip: When mounting CF Series arm brackets to Slatwall, bracket must be mounted no further than 10" away from Slatwall mounting bracket. If application does not allow bracket to be installed within the 10" range, an additional bracket or brackets should be installed within 10" of desired arm location.*



*Tip: C-clamp bracket is for use with worksurfaces with a thickness of 1" to 1 5/8".*



Standard Includes	Required to Specify
<ul style="list-style-type: none"> <li>• Bracket: paint</li> </ul>	1 Style number 2 Paint color number for bracket: 0835 Black 7018 Pewter 7027 Charcoal

Related Products	
<ul style="list-style-type: none"> <li>• CF Series flat panel monitor arm</li> <li>• CF Series flat panel monitor pole mounts</li> </ul>	<ul style="list-style-type: none"> <li>▶ Page 300</li> <li>▶ Page 301</li> </ul>

**Specification Information**

Weight	Style Number	U.S. Price

**Desk-Clamp/Grommet Bracket**

3.5 lb	<b>CFSPC</b>	\$50

**Through-Mount Bracket**

2.5 lb	<b>CFSPTM</b>	\$50

**Products on this page are Details, not turnstone.** They are included here to simplify your planning. Remember that Details has different pricing terms than turnstone products.



**For Canadian Pricing**  
 Multiply U.S. Price by the Canadian price factor.  
 ▶ See page 1 for details.

## FYI Single Flat Panel Monitor Arm and Supports with Mounting Brackets

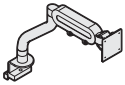

Tip: FYI flat panel arm support is for use with monitors 5 to 20 lb.

Tip: FYI flat panel monitor arm is not for use in front of stanchion mounted Slatwall.

Tip: Monitor arms with C-clamp brackets are not recommended on Universal tables with P-edge as the user's edge wraps all the way around. Universal Systems Worksurfaces with P-edge will work as the user's edge is applied to the front only.

Tip: C-clamp bracket is for use with worksurfaces with a thickness of 1" to 2 1/2".

Tip: Single monitor arm can be mounted on 12"H slatwall skin that has an installed brace package.

Standard Includes	Required to Specify
<ul style="list-style-type: none"> <li>• Monitor arm: paint</li> <li>• 75 mm/100 mm VESA plate</li> <li>• Mounting bracket</li> </ul>	<ul style="list-style-type: none"> <li>1 Style number</li> <li>2 Paint color number for monitor arm:                             <ul style="list-style-type: none"> <li>4231 Arctic White</li> <li>4710 Low Gloss Black</li> <li>4799 Platinum</li> </ul> </li> </ul>

Specification Information					
• Dimensions			• Weight	• Style	• U.S.
D	W	H		Number	Price
•	•	•	•	•	•
•	•	•	•	•	•

### C-Clamp Mounting Bracket

4"	14"	15"	13.5 lb	<b>FPASINGLECC</b>	\$384
•	•	•	•	•	•

Worktools

**Products on this page are Details, not turnstone.** They are included here to simplify your planning. Remember that Details has different pricing terms than turnstone products.



**For Canadian Pricing**  
Multiply U.S. Price by the Canadian price factor.  
▶ See page 1 for details.

# Series 5 Height-Adjustable Worksurfaces

High-Pressure Laminate

*Tip: Series 5 Height-Adjustable base requires assembly and attachment to the worksurface.*

*Tip: Worksurface ships with pre-drilled holes for mounting bases.*

*Tip: Maximum distributed load-bearing capacity is 220 lb per table including worksurface.*

*Tip: Mobile pedestals higher than 24" will impede the lowest height range of worksurface.*

*Tip: Worksurface overhang for pedestal storage varies by shape and size. Use the Details online Adjustable tool for specifics.*

*Tip: For help determining privacy/modesty screen, cableway, SOTO rail, and SlatRail width compatibility, see Worktools Compatibility Charts, in Details Specification Guide.*

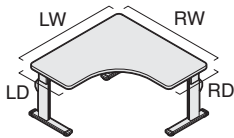
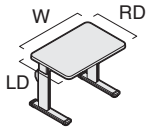

Standard Includes	Required to Specify
<ul style="list-style-type: none"> <li>High-Pressure Laminate</li> <li>High-Pressure Laminate worksurface edges:                             <ul style="list-style-type: none"> <li>–Universal Tables: plastic 3 mm edge profile on all sides</li> </ul> </li> <li>Worksurface corners:                             <ul style="list-style-type: none"> <li>–Radius corners on Universal Tables</li> </ul> </li> <li>Electric Height-Adjustable sit-to-stand base: paint</li> <li>Push button up/down controller</li> <li>Telescoping stretchers</li> <li>Dual-arm spring assist mechanism for bi-level table, if selected</li> <li>Wire manager</li> <li>Drive shaft cover</li> <li>Power cord: 9'</li> <li>Attachment hardware</li> </ul>	<ol style="list-style-type: none"> <li>Style number</li> <li>High-Pressure Laminate color number for worksurface</li> <li>Plastic color number for profile edge</li> <li>Paint color for base:                             <ul style="list-style-type: none"> <li>0835 Black</li> <li>4799 Platinum</li> </ul> </li> <li>Options, if selected (see below)                             <ul style="list-style-type: none"> <li>▶ See Surface Materials in <i>Details Specification Guide</i>.</li> </ul> </li> </ol>

Options	U.S. Price	Required to Specify
<b>Surface Materials</b> <ul style="list-style-type: none"> <li>High-Pressure Laminate worksurfaces</li> <li>Open Line laminate                             <ul style="list-style-type: none"> <li>+ \$67 plus cost of laminate</li> </ul> </li> </ul>		▶ See <i>Surface Materials Reference Manual</i> .
<b>Glides</b> <ul style="list-style-type: none"> <li>1" adjustable glides</li> </ul>	+ \$28	Specify with 1" glides.
<b>Related Products</b> <ul style="list-style-type: none"> <li>Slatwall, SlatRail, and Freestanding Worktools</li> <li>SOTO worktools</li> <li>Flat panel monitor arm support assemblies</li> </ul>		<ul style="list-style-type: none"> <li>▶ Pages 278-282</li> <li>▶ Pages 283-290</li> <li>▶ Page 298</li> </ul>

## Specification Information

Dimensions	Style	U.S.
W LD RD	Number	Base Price

### Rectangular Worksurface

58"	23"	23"	<b>A5RQ582323U</b>	\$1877

### 90° Equal Worksurface

58"	23"	58"	23"	<b>A5LQ58235823U</b>	\$2897

**Products on this page are Details, not turnstone.** They are included here to simplify your planning. Remember that Details has different pricing terms than turnstone products.



**For Canadian Pricing**  
 Multiply U.S. Price by the Canadian price factor.  
 ▶ See page 1 for details.

---

# Surface Materials

<b>Surface Materials Listing</b>	<b>306</b>
<b>Tour Workspace</b>	<b>128</b>
<b>Campfire</b>	<b>159</b>
<b>Seating</b>	<b>247</b>
<b>Tables</b>	<b>263</b>
<b>Paint Matrix</b>	<b>310</b>
<b>Understanding Low-Pressure and High-Pressure Laminates</b>	<b>311</b>
<b>Specification Rule for Selectable Edge Band and Rules for High-Pressure Laminates</b>	<b>312</b>
<b>turnstone Laminate Core Palette Matrix</b>	<b>314</b>
<b>Recommended Edge Banding Finishes for Low-Pressure Laminate and High-Pressure Laminate Products</b>	<b>316</b>
<b>Edge Banding Color Defaults</b>	<b>319</b>
<b>Open Line Laminate</b>	<b>320</b>
<b>Wood Matrix</b>	<b>321</b>
<b>Plastic Matrix</b>	<b>322</b>
<b>Seating Upholstery Matrix</b>	<b>323</b>
<b>Understanding Customer's Own Material (COM)</b>	<b>324</b>
<b>Maintenance and Cleaning</b>	<b>326</b>

# Surface Materials Listing

## Vertical Surface Fabrics

### Steelcase Surfaces

#### Boccie

Price Group 1

<b>P200</b> New Rice	<b>P205</b> New Mist
<b>P201</b> New Almond	<b>P206</b> New Plum
<b>P202</b> New Nutmeg	<b>P207</b> New Lichen
<b>P203</b> New Camel	<b>P208</b> New Spearmint
<b>P204</b> New Opal	<b>P209</b> New Sky

#### Buzz2

Price Group 1

<b>5F01</b> Camel <b>E</b>	<b>5G52</b> Barley
<b>5F03</b> Tomato	<b>5G53</b> Sunrise
<b>5F04</b> Red <b>E</b>	<b>5G54</b> Carrot
<b>5F05</b> Burgundy	<b>5G55</b> Pumpkin
<b>5F06</b> Sky <b>E</b>	<b>5G56</b> Timber
<b>5F07</b> Blue	<b>5G57</b> Rouge
<b>5F08</b> Navy	<b>5G58</b> Chocolate
<b>5F10</b> Grape <b>E</b>	<b>5G59</b> Meadow
<b>5F11</b> Eggplant <b>E</b>	<b>5G60</b> Ivy
<b>5F15</b> Stone	<b>5G61</b> Cyan
<b>5F16</b> Grey	<b>5G62</b> Atlantic
<b>5F17</b> Black	<b>5G63</b> Crocus
<b>5G50</b> Dunegrass	<b>5G64</b> Alpine
<b>5G51</b> Sable	<b>5G65</b> Tornado

**E** = Established

## Seating Upholstery

### Steelcase Surfaces

*Tip: All Steelcase Textiles Price Group 3 upholstery requires an additional leadtime of two or more weeks.*

#### Bo Peep

Price Group 5

<b>5G66</b> Pita	<b>5G77</b> Grapevine
<b>5G67</b> Bone	<b>5G78</b> Firefly
<b>5G68</b> Safari	<b>5G79</b> Artichoke
<b>5G69</b> Brown Sugar	<b>5G80</b> Serpent
<b>5G70</b> Chocolate Chip	<b>5G81</b> Carolina
<b>5G71</b> Candlelight	<b>5G82</b> Blue Bonnet
<b>5G72</b> Honey Mustard	<b>5G83</b> Nautical
<b>5G73</b> Marmalade	<b>5G84</b> Gravel
<b>5G74</b> Picnic	<b>5G85</b> Sharkskin
<b>5G75</b> Pinot	<b>5G86</b> Kohl
<b>5G76</b> Bloom	

#### Brisa

Price Group 6

<b>BR01</b> Black Onyx	<b>BR14</b> Pompeian Red
<b>BR04</b> Truffle	<b>BR15</b> Salsa
<b>BR06</b> Ash	<b>BR16</b> Cinnabar
<b>BR07</b> Sage	<b>BR17</b> Aztec
<b>BR08</b> Celery	<b>BR18</b> New Sand
<b>BR09</b> Sterling Blue	<b>BR19</b> Cream
<b>BR10</b> Night Navy	<b>BR20</b> White
<b>BR11</b> Cambridge Blue	<b>BR21</b> Moccasin
<b>BR12</b> Abyss	<b>BR22</b> Buckskin
<b>BR13</b> Canyon	<b>BR23</b> Prairie

#### Buzz2

Price Group 1

<b>5F01</b> Camel <b>E</b>	<b>5G52</b> Barley
<b>5F03</b> Tomato	<b>5G53</b> Sunrise
<b>5F04</b> Red <b>E</b>	<b>5G54</b> Carrot
<b>5F05</b> Burgundy	<b>5G55</b> Pumpkin
<b>5F06</b> Sky <b>E</b>	<b>5G56</b> Timber
<b>5F07</b> Blue	<b>5G57</b> Rouge
<b>5F08</b> Navy	<b>5G58</b> Chocolate
<b>5F10</b> Grape <b>E</b>	<b>5G59</b> Meadow
<b>5F11</b> Eggplant <b>E</b>	<b>5G60</b> Ivy
<b>5F15</b> Stone	<b>5G61</b> Cyan
<b>5F16</b> Grey	<b>5G62</b> Atlantic
<b>5F17</b> Black	<b>5G63</b> Crocus
<b>5G50</b> Dunegrass	<b>5G64</b> Alpine
<b>5G51</b> Sable	<b>5G65</b> Tornado

#### Chainmail

Price Group 2

<b>5550</b> Cotton	<b>5555</b> Tricycle
<b>5551</b> Space	<b>5556</b> Geranium
<b>5552</b> Silver Dollar	<b>5557</b> Banana
<b>5553</b> Volcano	<b>5558</b> Margarita
<b>5554</b> Orange Crush	<b>5559</b> Lagoon

**Cogent: Connect**

Price Group 2

<b>5S15</b> Coconut	<b>5S27</b> Malt
<b>5S16</b> Turmeric	<b>5S28</b> Root Beer
<b>5S17</b> Tangerine	<b>5S93</b> Blueprint
<b>5S18</b> Scarlet	<b>5S94</b> Lizard
<b>5S19</b> Concord	<b>5S95</b> Sailor
<b>5S20</b> Maya Blue	<b>5S96</b> Quicksilver
<b>5S21</b> Blue Jay	<b>5S97</b> Nugget
<b>5S23</b> Wasabi	<b>5S98</b> Canary
<b>5S24</b> Nickel	<b>5S99</b> Lipstick
<b>5S25</b> Graphite	<b>5SD0</b> Royal Blue
<b>5S26</b> Licorice	

**Cogent: Geode Seating ③**

Price Group 2

<b>5S47</b> Coal	<b>5S50</b> Ink
<b>5S49</b> Cobalt	

**Cogent: Geode Vertical ③**

Price Group 2

<b>5S32</b> Canyon	<b>5S38</b> Oyster
<b>5S35</b> Slate	<b>5S41</b> Sesame
<b>5S36</b> Cement	

**Cogent: Trails**

Price Group 2

<b>5S29</b> Bronzite	<b>5S88</b> Quartz
<b>5S85</b> Agate	<b>5S90</b> Tiger Eye
<b>5S86</b> Lapis	<b>5S91</b> Travertine
<b>5S87</b> Malachite	<b>5S92</b> Topaz

**Crosswalk ③**

Price Group 2

<b>5F48</b> Beech	<b>5F53</b> Persimmon
<b>5F49</b> Moon	<b>5F54</b> Bittersweet
<b>5F50</b> Berry	<b>5F55</b> Midnight
<b>5F51</b> Admiral Blue	<b>5F56</b> Poppy
<b>5F52</b> Moss	

③ = Established

**Gaja - C2C**

Price Group 3

<b>5W40</b> Black	<b>5W52</b> Emerald
<b>5W41</b> Pepper	<b>5W53</b> Snow Pea
<b>5W42</b> Pearl Grey	<b>5W54</b> Olive
<b>5W43</b> Crimson	<b>5W55</b> Light Blue
<b>5W44</b> Ink	<b>5W56</b> Maroon
<b>5W45</b> Night Blue	<b>5W57</b> Black Raspberry
<b>5W46</b> Petrol	<b>5W58</b> Spruce
<b>5W47</b> Greige	<b>5W59</b> Apple Green
<b>5W48</b> Sepia	<b>5W60</b> Deep Blue
<b>5W49</b> Umber	<b>5W61</b> Chili Pepper
<b>5W50</b> Java	<b>5W62</b> Daffodil
<b>5W51</b> Camellia Red	

**Imperma**

Price Group 3

<b>TM01</b> Toffee	<b>TM08</b> Cliff
<b>TM02</b> Pigeon	<b>TM09</b> Tarragon
<b>TM03</b> Fossil	<b>TM10</b> Pesto
<b>TM04</b> Poppyseed	<b>TM11</b> Wave
<b>TM05</b> Auburn	<b>TM12</b> Niagara
<b>TM06</b> Cumin	<b>TM13</b> Tuscan
<b>TM07</b> Marble	<b>TM14</b> Peppercorn

**Jacks**

Price Group 1

<b>5B61</b> Taupe ③	<b>5B64</b> Pewter ③
<b>5B63</b> Camel ③	<b>5B70</b> Midnight ③

**Link**

Price Group 1

<b>5A20</b> Burgundy	<b>5A26</b> Purple
<b>5A23</b> Green	<b>5A27</b> Black
<b>5A24</b> Blue	<b>5A28</b> Ocean
<b>5A25</b> Navy	<b>5A30</b> Chamois

**Nitelights**

Price Group 2

<b>5F58</b> Hazelnut	<b>5F63</b> Moss
<b>5F59</b> Burgundy	<b>5F64</b> Sea
<b>5F60</b> Cherry	<b>5F65</b> Regal Blue
<b>5F61</b> Earth	<b>5F66</b> Stone
<b>5F62</b> Shore	<b>5F67</b> Moon

## Surface Materials Listing, continued

### Playground <sup>®</sup>

Price Group 1

<b>5F28</b> Claret	<b>5F33</b> Stone
<b>5F29</b> Chile	<b>5F34</b> Sky
<b>5F30</b> Amber	<b>5F35</b> Navy
<b>5F31</b> Nut	<b>5F36</b> Huckleberry
<b>5F32</b> Blade	<b>5F37</b> Charcoal

### Redeem

Price Group 3

<b>TM50</b> Brick	<b>TM59</b> Carmel
<b>TM51</b> Yolk	<b>TM60</b> Greyhound
<b>TM52</b> Cinnamon	<b>TM61</b> Mocha
<b>TM53</b> Daisy	<b>TM62</b> Iceberg
<b>TM54</b> Pine	<b>TM64</b> Chestnut
<b>TM55</b> Water	<b>TM65</b> Cashmere
<b>TM56</b> Dill	<b>TM66</b> Barnwood
<b>TM57</b> Lavender	
<b>TM58</b> Mallard	

### Remix

Price Group 5

<b>RE01</b> Rust	<b>RE08</b> Concrete Grey
<b>RE02</b> Pumpkin	<b>RE09</b> Sky Blue
<b>RE03</b> Pebble	<b>RE10</b> Blue Jean
<b>RE04</b> Dark Chocolate	<b>RE11</b> Ivy Green
<b>RE05</b> Beige	<b>RE12</b> Primavera Yellow
<b>RE06</b> Linen Beige	<b>RE13</b> Night Blue
<b>RE07</b> Hazelnut	

### Retrieve

Price Group 3

<b>TM30</b> Kelly	<b>TM38</b> Driftwood
<b>TM31</b> Lake	<b>TM39</b> Bistro
<b>TM32</b> Gala	<b>TM40</b> Quarry
<b>TM33</b> Papaya	<b>TM41</b> Mohair
<b>TM34</b> Dandelion	<b>TM42</b> Shadow
<b>TM35</b> Curry	<b>TM43</b> Seal
<b>TM36</b> Lilac	<b>TM44</b> Chalk
<b>TM37</b> Submarine	

### Spyder <sup>®</sup>

Price Group 2

<b>5B01</b> Foggy Night	<b>5B04</b> Peri
-------------------------	------------------

### Stand In

Price Group 2

<b>5621</b> Sleet	<b>5630</b> Apple
<b>5622</b> Lunar	<b>5631</b> Lava
<b>5623</b> Cyclone	<b>5632</b> Cayenne
<b>5624</b> Eclipse	<b>5633</b> Plantain
<b>5625</b> Powder	<b>5634</b> Parsley
<b>5626</b> Chardonnay	<b>5635</b> Scallion
<b>5627</b> Graham	<b>5636</b> Atlantis
<b>5628</b> Sediment	<b>5691</b> Orca
<b>5629</b> Allspice	

### Steelcut Trio

Price Group 7

<b>TR01</b> Mist Grey	<b>TR09</b> Raspberry Pink
<b>TR02</b> Stone Grey	<b>TR10</b> Myrtle Brown
<b>TR03</b> Cassonade Beige	<b>TR11</b> Ice Blue
<b>TR04</b> Nutmeg Beige	<b>TR12</b> Electric Blue
<b>TR05</b> Chocolate Blue	<b>TR13</b> Peppermint Green
<b>TR06</b> Licorice Black	<b>TR14</b> Blue Jay Mix
<b>TR07</b> Mustard Yellow	<b>TR15</b> Brown Frost
<b>TR08</b> Red Currant	<b>TR16</b> Lime Green

### Texel

Price Group 3

<b>TM20</b> Angora	<b>TM24</b> Nude
<b>TM21</b> Grist	<b>TM25</b> Field
<b>TM22</b> Galaxy	<b>TM26</b> Haze
<b>TM23</b> Terracotta	

### Zoe2 <sup>®</sup>

Price Group 2

<b>5C90</b> Eggplant	<b>5C95</b> Rain
<b>5C91</b> Aloe	<b>5C96</b> Grey Flannel
<b>5C92</b> Fiddle	<b>5C97</b> Pebble
<b>5C93</b> Patina	<b>5C98</b> Cymbal
<b>5C94</b> Peacock	<b>5C99</b> Fiesta

<sup>®</sup> = Established

## Select Surfaces Designtex Seating Upholstery

**For information on products within Select Surfaces,** including accent paints and fabrics from Designtex, Gabriel, Kvadrat, and Pollack, please refer to the *Surface Materials Reference Manual* or visit [Steelcase.com/selectsurfaces](http://Steelcase.com/selectsurfaces).

Please refer to the Steelcase COM database on [Steelcase.com](http://Steelcase.com) for the most current application information.

## Leather

### Steelcase Surfaces

#### turnstone Leather

**L304** Black  
**L305** Brown  
**T802** Black  
**T803** Port

#### Leather

Price Group Leather

<b>L107</b> Black	<b>L221</b> Rocky
<b>L207</b> Mahogany	<b>L500</b> Camel
<b>L220</b> Soapstone	<b>L503</b> Navy

## Seating Vinyl

### Steelcase Surfaces

#### Seating Vinyl <sup>Ⓔ</sup>

Price Group 2

<b>5801</b> Topaz	<b>5815</b> Seaside
<b>5805</b> Foggy Night	<b>5817</b> Pebble
<b>5809</b> Black	<b>5818</b> Spice
<b>5810</b> Forest	<b>5819</b> Thistle
<b>5812</b> Navy	<b>5820</b> Coffee
<b>5813</b> Currant	<b>5822</b> Iris
<b>5814</b> Leaf	

<sup>Ⓔ</sup> = Established

# Paint Matrix

For a surface materials listing of individual product lines, see *Surface Materials* at the end of each product chapter:

- ▶ Bivi, page 64
- ▶ Campfire, page 159
- ▶ Seating, page 247
- ▶ Tables, page 263
- ▶ Tour, page 128

	Bivi	Tour	Campfire Big Lamp	Campfire Big Table	Campfire LED Personal Task Light	Campfire Paper Table	Campfire Screen	Campfire Skate Table	Campfire Slim Table	Jenny Tablet Arm	Scoop	Shortcut	Simple Tables	Slatwall screens and Mounting Brackets
<b>Price Group 1</b>														
<b>Textured Paint</b>														
7207 Black	•	■	•	•	•	•	•	•	•	■	■	•	•	•
7225 Sand	•	■	•	•	•	•	•	•	•	•	•	•	•	•
7241 Arctic White	■	■	•	•	■	•	•	•	•	•	■	•	■	•
7243 Seagull	•	■	•	•	•	•	•	•	•	•	•	•	•	•
<b>Price Group 2</b>														
<b>Smooth Metallic Paint</b>														
4750 Champagne Metallic	•	■	•	•	•	•	•	•	•	•	•	•	•	•
4798 Sterling Metallic	•	■	•	•	•	•	•	•	•	•	•	•	•	■
4799 Platinum Metallic	■	■	■	■	■	•	•	■	■	•	■	■	■	■
<b>Textured Metallic Paint</b>														
7246 Midnight Metallic	■	■	■	•	•	•	•	■	■	•	•	•	■	•
<b>Accessory Paint</b>														
0835 Black	•	□	•	•	•	•	■	•	•	•	•	•	•	•
4140 Arctic White Gloss	□	•	■	•	•	■	•	■	■	•	•	■	•	•
4710 Low Gloss Black	•	•	•	•	■	•	•	•	•	•	•	•	•	•

Ships standard in 5-7 business days.

*Tip: Paint finishes 4750 Champagne Metallic, 7225 Sand, 7241 Arctic White, 7243 Seagull, and 7246 Midnight Metallic are available in 15 days delivered on Tour products only.*

## Legend

- = Not available
- = Available
- = Available with exceptions
- Ⓢ = Established
- ▶ See *Surface Materials* and *Specifying* pages.

**Products that are missing from the matrix are not available with these surface materials.**

# Understanding Low-Pressure and High-Pressure Laminates

Understanding  
Low-Pressure and High-  
Pressure Laminates

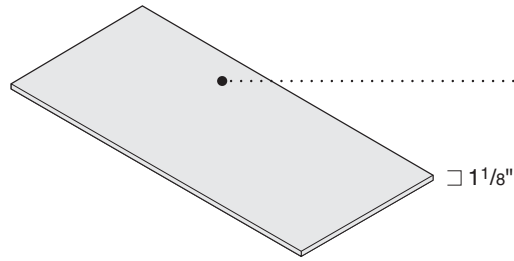

**Standard work surfaces on Jenny and Tour Workspace** are available in Low-Pressure Laminates and High-Pressure Laminates.

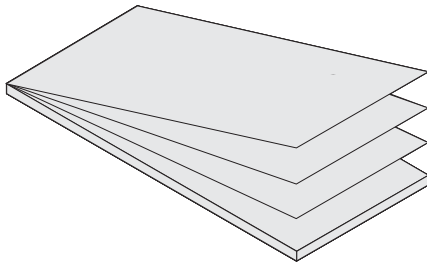

**High-Pressure Laminates, or HPLs,** are composed of multiple layers of crafted paper individually soaked in resin. There are 7-15 layers of paper combined to make the final sheet. The top layers are translucent melamine sheet and a decorative layer. The sheets are combined under heat and high pressure to form a single laminate sheet. The resulting sheet is then bonded under heat and high pressure to a wood core. HPLs are generally considered more durable than LPLs due to the extra layers of craft paper (backer) used in their creation. While they cost more, they are more durable. HPLs are generally used in higher traffic areas such as cafeterias and conference rooms. Generally, it is more cost effective to restrict their use to areas needing the added durability HPLs provide.

Surface Materials

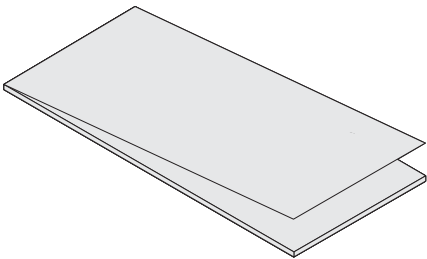

**Low-Pressure Laminates, or LPLs,** are created by dipping decorative crafted paper in melamine resin. The melamine dipped paper is then bonded to a wood core under heat and high-pressure. LPLs are generally suitable for use in lower impact areas. LPLs are generally used in vertical applications as well as tops for workstations and private offices. Generally, it is more cost effective to use LPLs when the performance of HPLs are not required.

# Specification Rule for Selectable Edge Band and Rules for High-Pressure Laminates

## Legend

- = Not available
- = Available

Selectable edge band (HPL)

### Selectable Edge band Available

#### Jenny

Tablet arms	■
End table	■
Coffee table	■

#### Tour Workspace

Counter	•
Counter infills	•
Counter tops	•
Shelves	■
Worksurfaces	■
Worksurface supports	•
Modesty panels	•
Screens	•
HV cabinets	•
Bookcases	•
Pile files	•
Campfire Slim Table	■
Campfire Skate Table	■

### Specification Rule for Selectable Edge band

When specifying tops, you are required to select an edge band color.

▶ See *Recommended Edge Banding Finishes for Low-Pressure Laminate and High-Pressure Laminate Products*, page 316.

You could select an edge band for a worksurface that is different than the default for the rest of the product in the work station (i.e. upper storage, towers, etc.)

### Rules for High-Pressure Laminates only

1. HPL can be used on worksurfaces and shelves for Tour.
2. HPL can also be used on these non-standard worksurfaces: Jenny tablet arms and tables.



# turnstone Laminate Core Palette Matrix

Applies to Tour, Jenny, and Campfire

Ships standard in 5-7 business days

For a surface materials listing of individual product lines, see *Surface Materials* at the end of each product chapter:

- ▶ Bivi, page 64
- ▶ Campfire, page 159
- ▶ Seating, page 247
- ▶ Tables, page 263
- ▶ Tour, page 128

	LPL & HPL Available:						Exceptions:					
	Campfire Paper Table	Campfire Skate Table	Campfire Slim Table	Jenny Tables	Jenny Tablet Arms	Tour Worksurfaces and Shelves	Bivi	Campfire Big Table	Campfire Storage Cabinets	Simple Tables	Tour Vertical Surfaces	Tour Countertops
<b>Low-Pressure Laminate (LPL)</b>												
247L Black Version 2 LPL	•	•	•	■	■	•	•	•	•	•	•	•
25L1 Winter on Maple LPL	•	•	•	■	■	■	•	•	•	•	■	■
25L5 Virginia Walnut LPL	•	■	■	■	■	■	■	■	■	■	■	■
25L6 Blackwood LPL	•	■	■	■	■	■	■	■	■	■	■	■
25L8 Clear Walnut LPL	•	■	■	■	■	■	■	■	■	■	■	■
25L9 Warm Oak LPL <sup>E</sup>	•	■	■	■	■	■	■	■	■	■	■	■
262L Marbled Maple LPL	•	•	•	■	■	•	•	•	•	•	•	•
264L Chocolate Walnut LPL	•	•	•	■	■	•	•	•	•	•	•	•
267L Marbled Cherry Version 2 LPL	•	•	•	■	■	•	•	•	•	•	•	•
26L1 Natural Cherry Version 2 LPL	•	■	■	■	■	■	•	■	■	•	■	■
2L03 Brushed Silver LPL	•	•	•	■	■	•	•	•	•	•	•	•
2L09 Clear Maple LPL	•	•	•	■	■	•	•	■	•	•	•	•
2L30 Arctic White LPL	•	■	■	■	■	■	■	■	■	•	■	■
2L50 Vanadium Fiber LPL	•	•	•	■	■	•	•	•	•	•	•	•
2L52 Tungsten Fiber LPL	•	•	•	■	■	•	•	•	•	•	•	•
2L83 Seagull LPL	•	•	•	■	■	•	•	•	■	•	•	•
2L85 Dune LPL	•	•	•	■	■	•	•	■	■	•	•	•
2LAK Clear Oak LPL	•	•	•	■	■	■	•	■	■	•	•	•
2LAT Acacia LPL	•	•	•	■	■	■	•	■	■	•	•	•
<b>High-Pressure Laminate (HPL)</b>												
2406 Clear Cherry HPL	•	■	■	■	■	■	•	•	•	•	•	•
2409 Clear Maple HPL	•	■	■	•	•	•	•	•	•	•	•	•
2410 Graphite Walnut HPL	•	■	■	•	•	•	•	•	•	•	•	•
2412 Natural Cherry Version 2 HPL	•	■	■	■	■	■	•	•	•	•	•	•
2422 Medium Cherry HPL	•	■	■	■	■	■	•	•	•	•	•	•
2503 Brushed Silver HPL	•	•	•	■	■	•	•	•	•	•	•	•
2511 Winter on Maple HPL	•	■	■	■	■	■	•	•	•	•	•	•
2535 Virginia Walnut HPL	■	■	■	■	■	■	•	•	•	•	•	•
2536 Blackwood HPL	■	■	■	■	■	■	•	•	•	•	•	•
2538 Clear Walnut HPL	■	■	■	■	■	■	•	•	•	•	•	•
2539 Warm Oak HPL <sup>E</sup>	■	■	■	■	■	■	•	•	•	•	•	•
2592 Blonde on Maple HPL	•	■	■	■	■	■	•	•	•	•	•	•
2612 Marbled Maple HPL	•	■	■	■	■	•	•	•	•	•	•	•
2614 Chocolate Walnut HPL	•	■	■	■	■	•	•	•	•	•	•	•
2615 Marbled Cherry Version 2 HPL	•	■	■	■	■	•	•	•	•	•	•	•
2714 Natural Walnut HPL	•	■	■	■	■	■	•	•	•	•	•	•
2722 Cream HPL	•	■	■	■	■	■	•	•	•	•	•	•
2730 Arctic White HPL	•	■	■	■	■	■	•	•	•	•	•	•
2746 Black HPL	•	■	■	■	■	•	•	•	•	•	•	•
2759 Warm White HPL	•	■	■	■	■	■	•	•	•	•	•	•

### Legend

- = Not available
- = Available
- = Available with exceptions
- <sup>E</sup> = Established
- ▶ See *Surface Materials* and *Specifying* pages.

**Products that are missing from the matrix are not available with these surface materials.**

### Color, stability, and lighting

Surface materials are formulated to maintain compatibility under horizon light, daylight, and cool white light. As a precaution, always select colors and materials under the specific type of lighting they will receive in actual office use. Particular care should be used with high intensity discharge light, which can adversely affect color compatibility. The swatch material on this card is provided as a color guideline. There may be variations in color, texture, and finish between this sample and the actual product.

For a surface materials listing of individual product lines, see *Surface Materials* at the end of each product chapter:

- ▶ Bivi, page 64
- ▶ Campfire, page 159
- ▶ Seating, page 247
- ▶ Tables, page 263
- ▶ Tour, page 128

	LPL & HPL Available:						Exceptions:					
	Campfire Paper Table	Campfire Skate Table	Campfire Slim Table	Jenny Tables	Jenny Tablet Arms	Tour Worksurfaces and Shelves	Bivi	Campfire Big Table	Campfire Storage Cabinets	Simple Tables	Tour Vertical Surfaces	Tour Countertops
<b>High-Pressure Laminate (HPL) Continued</b>												
2772 Medium Mahogany on Walnut HPL <sup>E</sup>	•	■	■	■	■	■	•	•	•	•	•	•
2811 Mist HPL <sup>E</sup>	•	■	■	■	■	■	•	•	•	•	•	•
2820 Coffee Speckle HPL	•	■	■	■	■	■	•	•	•	•	•	•
2822 Woodrose Speckle HPL <sup>E</sup>	•	■	■	■	■	■	•	•	•	•	•	•
2823 Driftwood Speckle HPL	•	■	■	■	■	■	•	•	•	•	•	•
2824 Smoke Speckle HPL	•	■	■	■	■	■	•	•	•	•	•	•
2825 Vanadium Speckle HPL	•	■	■	■	■	■	•	•	•	•	•	•
2850 Vanadium Fiber HPL	•	■	■	■	■	•	•	•	•	•	•	•
2851 Rhyme Fiber HPL <sup>E</sup>	•	■	■	■	■	■	•	•	•	•	•	•
2852 Tungsten Fiber HPL	•	■	■	■	■	•	•	•	•	•	•	•
2854 Vellum Fiber HPL	•	■	■	■	■	■	•	•	•	•	•	•
2859 Novell Fiber HPL	•	■	■	■	■	■	•	•	•	•	•	•
2860 Granite Fiber HPL	•	■	■	■	■	■	•	•	•	•	•	•
2861 Coconut Fiber HPL	•	■	■	■	■	■	•	•	•	•	•	•
2862 Stucco Fiber HPL	•	■	■	■	■	■	•	•	•	•	•	•
2870 Blonde Bronze Patina HPL	•	■	■	■	■	■	•	•	•	•	•	•
2871 Blackened Bronze Patina HPL	•	■	■	■	■	■	•	•	•	•	•	•
2873 Instant Iron Patina HPL	•	■	■	■	■	■	•	•	•	•	•	•
2883 Seagull HPL	•	■	■	■	■	•	•	•	•	•	•	•
2884 Milk HPL	•	■	■	■	■	■	•	•	•	•	•	•
2885 Dune HPL	•	■	■	■	■	•	•	•	•	•	•	•
2920 Marl Micro HPL	•	■	■	■	■	■	•	•	•	•	•	•
2921 Gypsum Micro HPL	•	■	■	■	■	■	•	•	•	•	•	•
2922 Clay Micro HPL	•	■	■	■	■	■	•	•	•	•	•	•
2923 Shadow Micro HPL <sup>E</sup>	•	■	■	■	■	■	•	•	•	•	•	•
2HAK Clear Oak HPL	•	■	■	■	■	■	•	•	•	•	•	•
2HAT Acacia HPL	•	■	■	■	■	■	•	•	•	•	•	•

**Legend**

- = Not available
- = Available
- = Available with exceptions
- <sup>E</sup> = Established
- ▶ See *Surface Materials* and Specifying pages.

**Products that are missing from the matrix are not available with these surface materials.**

**Color, stability, and lighting**

Surface materials are formulated to maintain compatibility under horizon light, daylight, and cool white light. As a precaution, always select colors and materials under the specific type of lighting they will receive in actual office use. Particular care should be used with high intensity discharge light, which can adversely affect color compatibility. The swatch material on this card is provided as a color guideline. There may be variations in color, texture, and finish between this sample and the actual product.

# Recommended Edge Banding Finishes for Low-Pressure Laminate and High-Pressure Laminate Products

## For use on: Jenny

High-Pressure Laminate Color	Recommended Edge Band
2422 Medium Cherry	6036 Medium Cherry
2592 Blonde on Maple	6038 Blonde On Maple
2714 Natural Walnut	6041 Natural Walnut
2820 Coffee Speckle	6631 Cream
2822 Woodrose Speckle <b>E</b>	6635 Dawn <b>E</b>
2823 Driftwood Speckle	6631 Cream
2824 Smoke Speckle	6636 Mist
2825 Vanadium Speckle	6619 Ice <b>E</b>
2851 Rhyme Fiber <b>E</b>	6631 Cream
2854 Vellum Fiber	6655 Warm White
2859 Novell Fiber	6001 Coffee
2860 Granite Fiber	6000 Black
2861 Coconut Fiber	6654 Sand
2862 Stucco Fiber	6053 Seagull
2870 Blonde Bronze Patina	6654 Sand
2871 Blackened Bronze Patina	6615 Grey Value 5
2873 Instant Iron Patina	6615 Grey Value 5
2884 Milk	6052 Milk
2920 Marl Micro	6053 Seagull
2921 Gypsum Micro	6654 Sand
2922 Clay Micro	6654 Sand
2923 Shadow Micro <b>E</b>	6249 Platinum Solid

Low-Pressure Laminate Color	Recommended Edge Band
25L1 Winter on Maple LPL	6037 Winter on Maple
25L5 Virginia Walnut LPL	6242 Virginia Walnut
25L6 Blackwood LPL	6243 Blackwood
25L8 Clear Walnut LPL	6245 Clear Walnut
25L9 Warm Oak LPL <b>E</b>	6246 Warm Oak <b>E</b>
26L1 Natural Cherry Version 2 LPL	6034 Natural Cherry
2L30 Arctic White LPL	6009 Arctic White
2LAT Acacia LPL	6213 Acacia

**E** = Established

**For Use on: Tour**

<b>High-Pressure Laminate Color</b>		<b>Recommended Edge Band</b>	
2422	Medium Cherry	6036	Medium Cherry
2592	Blonde on Maple	6038	Blonde on Maple
2714	Natural Walnut	6041	Natural Walnut
2820	Coffee Speckle	6631	Cream
2822	Woodrose Speckle <b>E</b>	6635	Dawn <b>E</b>
2823	Driftwood Speckle	6631	Cream
2824	Smoke Speckle	6636	Mist
2825	Vanadium Speckle	6619	Ice <b>E</b>
2851	Rhyme Fiber <b>E</b>	6631	Cream
2854	Vellum Fiber	6655	Warm White
2859	Novell Fiber	6001	Coffee
2860	Granite Fiber	6000	Black
2861	Coconut Fiber	6654	Sand
2862	Stucco Fiber	6053	Seagull
2870	Blonde Bronze Patina	6654	Sand
2871	Blackened Bronze Patina	6615	Grey Value 5
2873	Instant Iron Patina	6615	Grey Value 5
2884	Milk	6052	Milk
2920	Marl Micro	6053	Seagull
2921	Gypsum Micro	6654	Sand
2922	Clay Micro	6654	Sand
2923	Shadow Micro <b>E</b>	6249	Platinum Solid

<b>Low-Pressure Laminate Color</b>		<b>Recommended Edge Band</b>	
25L1	Winter on Maple LPL	6037	Winter on Maple
25L5	Virginia Walnut LPL	6242	Virginia Walnut
25L6	Blackwood LPL	6243	Blackwood
25L8	Clear Walnut LPL	6245	Clear Walnut
25L9	Warm Oak LPL <b>E</b>	6246	Warm Oak <b>E</b>
26L1	Natural Cherry Version 2 LPL	6034	Natural Cherry
2L30	Arctic White LPL	6009	Arctic White

**E** = Established

Recommended Edge Banding Finishes for Low-Pressure Laminate and High-Pressure Laminate Products , continued

**For Use on: Campfire Slim Table and Skate Table**

<b>High-Pressure Laminate Color</b>		<b>Recommended Edge Band</b>	
2406	Clear Cherry	6234	Clear Cherry
2409	Clear Maple	6237	Clear Maple
2410	Graphite Walnut	6231	Graphite Walnut
2412	Natural Cherry	6034	Natural Cherry
2422	Medium Cherry	6036	Medium Cherry
2511	Winter on Maple	6037	Winter on Maple
2535	Virginia Walnut	6242	Virginia Walnut
2536	Blackwood	6243	Blackwood
2538	Clear Walnut	6245	Clear Walnut
2539	Warm Oak <b>E</b>	6246	Warm Oak
2592	Blonde on Maple	6038	Blonde on Maple
2612	Marbled Maple	6676	Marbled Maple
2614	Chocolate Walnut	6677	Chocolate Walnut
2615	Marbled Cherry	6878	Marbled Cherry
2714	Natural Walnut	6041	Natural Walnut
2722	Cream <b>E</b>	6631	Cream
2730	Arctic White	6009	Arctic White
2746	Black	6000	Black
2759	Warm White <b>E</b>	2759	Warm White
2772	Medium Mahogany on Walnut <b>E</b>	6045	Medium Mahogany on Walnut <b>E</b>
2811	Mist <b>E</b>	6636	Mist
2820	Coffee Speckle	6631	Cream
2822	Woodrose Speckle <b>E</b>	6635	Dawn <b>E</b>
2823	Driftwood Speckle	6631	Cream
2824	Smoke Speckle	6636	Mist
2825	Vanadium Speckle	6619	Ice <b>E</b>
2850	Vanadium Fiber	6654	Sand
2851	Rhyme Fiber <b>E</b>	6631	Cream
2852	Tungsten Fiber	6636	Mist
2854	Vellum Fiber	6655	Warm White
2859	Novell Fiber	6001	Coffee
2860	Granite Fiber	6000	Black
2861	Coconut Fiber	6654	Sand
2862	Stucco Fiber	6053	Seagull
2870	Blonde Bronze Patina	6654	Sand
2871	Blackened Bronze Patina	6615	Grey Value 5
2873	Instant Iron Patina	6615	Grey Value 5
2883	Seagull	6053	Seagull
2884	Milk	6052	Milk
2885	Dune	6654	Dune
2920	Marl Micro	6053	Seagull
2921	Gypsum Micro	6654	Sand
2922	Clay Micro	6654	Sand
2923	Shadow Micro <b>E</b>	6249	Platinum Solid
2HAK	Clear Oak	6219	Clear Oak
2HAT	Acacia	6213	Acacia
<b>Low-Pressure Laminate Color</b>		<b>Recommended Edge Band</b>	
25L5	Virginia Walnut LPL	6242	Virginia Walnut
25L6	Blackwood LPL	6243	Blackwood
25L8	Clear Walnut LPL	6245	Clear Walnut
25L9	Warm Oak LPL <b>E</b>	6246	Warm Oak <b>E</b>
26L1	Natural Cherry Version 2 LPL	6034	Natural Cherry
2L30	Arctic White LPL	6009	Arctic White

**E** = Established

## alight lounge

Wood

**Plastic edge plastic color** on worksurfaces is a default and cannot be specified. It is determined by the wood color specified.

Wood Color	Default Veneer Edge Color
3412 Natural Cherry <sup>E</sup>	Natural Cherry
3522 Clear Maple	Clear Maple
3762 Dark Walnut	Dark Walnut

*Tip: Steelcase's transition to PVC-free edge banding is beginning in July 2008. Check in.2.steelcase.com to see which edge colors and profiles have switched to PVC-free plastic.*

<sup>E</sup> = Established

# Open Line Laminate

The Open Line Laminate (OLL) Program offers the opportunity for customers to select laminates that are not offered through the standard turnstone laminate offering for use on turnstone products.

The following products are available using the OLL process: Jenny and Tour.

An additional feature of the Open Line Laminate Program is the ability to order different edge colors (other than the default edge color specified in the specification guide) for use with standard turnstone laminates. See below for pricing information for this application.

## Application Testing/Approval

To order an Open Line laminate on a turnstone product, first confirm that the selected laminate has been tested and approved for use on a specific product by checking the custom surface materials Web site at [www.steelcase.com/com](http://www.steelcase.com/com).

If the laminate is **approved**, you may continue the ordering process. If the laminate has **failed** to meet testing and approval standards, you must choose another laminate. If the laminate is **not listed**, turnstone laminate.

To have your material tested, send the following materials to Steelcase:

- One (1) 4' x 8' sheet of high-pressure decorative laminate that is vertical grade, post formable (VGP), and 0.028" (0.7 mm) thick
- A completed Open Line Laminate Testing Request Form

Access the Web site at [www.steelcase.com](http://www.steelcase.com).

Under surface materials, select custom surface materials and the Open Line laminate option. The test request form can be found under "create test request".

*Note: All information on the form is required in order to complete testing.*

**Send your laminate materials to:  
Steelcase Inc.  
Attn: OLL Testing Department  
901 44th Street  
Grand Rapids, MI 49508**

## Submit Request

Use the electronic Open Line Laminate Testing Request Form found on the Steelcase custom surface materials Web site under the "How To Test" tab, or fax a copy of the form to 616.698.4700.

## Test Results

Test results will be returned by fax or e-mail in four working days from receipt of laminate and form.

Not all testing is based on actual production conditions. Because some laminates vary in fabrication, turnstone reserves the right to reject any non-standard laminates that do not meet manufacturing requirements, even though the sample passed initial testing.

## Application Direction

Open Line laminates are applied to products in the turnstone standard application direction. For directional laminates, each individual specification guide shows the standard application direction for that product. Application in other than standard direction must be processed through Specials Engineering.

## Open Line Laminates Square Footage Requirements

To determine how much laminate you will need, access the calculator found on the Steelcase custom surface materials Web site at [www.steelcase.com/com](http://www.steelcase.com/com). Material estimates will vary depending on the following items:

- Laminate properties
- Laminate directionality
- Sheet sizes offered by the vendor
- Edge type
- Product style number
- Quantity of products being manufactured

## Open Line Laminates Pricing

Open Line laminates are available at an additional \$67 (U.S.) per surface, plus the cost of the laminate. If you select Formica, Nevamar, Pionite, or WilsonArt laminate, the cost of the laminate is \$1.10 (U.S.) per square foot. (Non-Discountable)

Example:  
4' x 8' sheet = 32 square feet  
32 square feet x \$1.10 = \$35.20 (U.S.)  
per sheet

Laminate cost may vary for other suppliers. Please contact the OLL consultant at 616.475.2426 for pricing. The cost of the laminate will be added to your invoice as a separate line on the acknowledgement.

There are no additional charges beyond the initial \$67 U.S. list to obtain **different edge colors with turnstone standard laminates.**

**Special engineering products** using the Open Line laminate process will be priced at \$67 (U.S. list) per surface, plus the cost of the laminate. If you select Formica, Nevamar, Pionite, or Wilson Art laminate to be used on Special Engineering products, the cost of the laminate is \$45 (U.S.) per surface. (Non-Discountable).

There are no additional charges beyond the initial \$67 (U.S. list) and any applicable Special Engineering charges to obtain different edge colors with turnstone standard laminates.

## How to Order

Once you have confirmed that the laminate you've selected has been tested and approved, you are ready to place your order.

To order an Open Line laminate on a turnstone product:

- Mark the purchase order with the
  - Laminate manufacturer,
  - Laminate number, and
  - Laminate description
- Use the appropriate Open Line laminate number (2900).
- Use the appropriate edge band color number to indicate the edge color requirements.

The order is subject to the manufacturer's minimum order requirements. Please contact the laminate supplier for verification of minimum order requirements before ordering.

## turnstone to Purchase Service

The Open Line Laminate Program includes a service to purchase approved Open Line laminates for use on turnstone products.

**turnstone will facilitate the ordering, scheduling, and shipment of Open Line laminates directly from the suppliers and will apply it to the product.**

turnstone is the only party that may purchase material. The only time the customer purchases material is for testing purposes.

Additional lead times apply to all orders specifying Open Line laminates.

turnstone is not responsible for overages and will not issue credit for any differences between the estimated amount provided and the actual amount ordered and acknowledged.

Laminate suppliers require laminate to be purchased in full sheets. turnstone will determine how many sheets are needed and order appropriately.

## Contact

For Open Line laminate test results, Application Test Request Form, or square foot requirements, visit the custom surface materials Web site at [www.steelcase.com/com](http://www.steelcase.com/com).

For additional information call  
1.800.TURNSTONE

For a surface materials listing of individual product lines, see *Surface Materials* at the end of each product chapter:  
 ▶ Campfire, page 159  
 ▶ Seating, page 247

	Wood Finish			
	3412 Natural Cherry	3522 Clear Maple	3611 Natural Oak	3762 Dark Walnut
alight lounge ottomans	■	■	•	■
alight occasional tables	■	■	•	■
Campfire personal table	•	•	■	•
Campfire skate table	•	•	■	•
Campfire slim table	•	•	■	•
Jenny	■	■	•	■

*Tip: The wood used in the construction of chairs is either maple or European beech. Wood finishes will match, but will not have the same natural grain.*

*Note: Wood color 3522 is a clear coat. Therefore, the natural variations in wood (maple or European beech) will be visible.*

*Note: Due to natural variations in wood, finished products may vary in color, texture and grain.*

### Legend

- = Not available
- = Available
- = Available with exceptions
- Ⓢ = Established
- ▶ See *Surface Materials* and Specifying pages.

# Plastic Matrix

For a surface materials listing of individual product lines, see *Surface Materials* at the end of each product chapter:

- ▶ Bivi, page 64
- ▶ Seating, page 247
- ▶ Tables, page 263

	Bivi Screen Pucks	Buoy	Campfire Footrest	Campfire LED Personal Task Light	Campfire Paper Table	Cobi Select	Scoop	Shortcut	Translucent Screens	Sweeper Martini Table
6009 Arctic White	■	■	■	■	■	•	•	■	•	•
6059 Sterling Dark Solid	•	•	•	•	•	•	•	■	•	•
627T Black	•	•	•	•	•	•	•	•	•	■
6205 Black	•	■	•	•	•	•	•	■	•	•
6249 Platinum Solid	■	•	•	•	•	•	•	•	•	•
628T Natural	•	•	•	•	•	•	•	•	•	■
6295 Near Black	•	•	•	•	•	■	•	•	•	•
631T Dark Grey	•	•	•	•	•	•	•	•	•	■
6333 Picasso	•	■	■	•	•	•	•	■	•	•
6335 Wasabi	•	■	■	•	•	•	•	■	•	•
6337 Element	•	■	•	•	•	•	•	■	•	•
6338 Chili	•	■	■	•	•	•	•	■	•	•
6505 Frosted White	•	•	•	•	•	•	•	•	■	•
6507 Frosted Green	•	•	•	•	•	•	•	•	■	•
6527 Merle	•	■	■	•	•	•	•	•	•	•
6618 White	•	•	•	•	•	•	■	■	•	•
6682 Cobblestone	•	•	•	•	•	•	■	■	•	•
6695 Midnight	■	•	•	•	•	•	•	•	•	•

## Legend

- = Not available
- = Available
- = Available with exceptions
- ⊙ = Established
- ▶ See *Surface Materials* and Specifying pages.

**Products that are missing from the matrix are not available with these surface materials.**

# Seating Upholstery Matrix

turnstone

Seating Upholstery Matrix

	Price Group	alight Lounge Series	Buoy	Campfire Big Lamp	Campfire Big Lounge	cobi Select	Hoodie	Jack Task Chairs	Jenny Lounge	Lincoln Lounge	Reply Select - Mesh Back	Rumble Seat	Scoop - Upholstered Seat	Shortcut	Tour - Lateral File Cushion	Uno Select
<b>Bo Peep</b>	5	■	■	•	■	•	•	■	■	•	•	•	■	■	■	•
<b>Brisa</b>	6	■	•	•	■	•	•	■	■	•	•	•	■	■	■	•
<b>Buzz2</b>	1	■	■	•	■	•	•	■	■	•	■	•	■	■	■	■
<b>Chainmail</b>	2	■	■	•	■	•	•	■	■	•	•	•	■	■	■	■
<b>Cogent: Connect</b>	2	■	■	■	■	■	■	■	■	•	•	■	■	■	■	■
<b>Cogent: Geode Seating</b>	2	■	•	•	•	•	•	■	■	•	•	•	■	•	■	•
<b>Cogent: Geode Vertical</b>	2	■	•	•	•	•	•	■	■	•	•	•	■	•	■	•
<b>Cogent: Trails</b>	2	■	•	•	■	•	•	■	■	•	•	•	■	■	■	•
<b>Crosswalk</b>	2	■	•	•	■	•	•	■	■	•	•	•	■	■	■	•
<b>Elmosoft Leather</b>	EL	•	•	•	•	•	•	•	•	•	•	•	■	•	•	•
<b>Gaja — C2C</b>	3	■	•	•	■	•	•	■	■	•	•	•	■	■	■	•
<b>Imperma</b>	3	■	•	•	■	•	•	■	■	•	•	•	■	•	•	•
<b>Jacks</b>	1	■	•	•	■	•	•	■	■	•	•	•	■	■	■	•
<b>Turnstone Leather</b>	NA	•	•	•	•	•	•	•	■	•	•	•	•	•	•	•
<b>Steelcase Leather</b>	L	•	•	•	•	•	•	•	■	•	•	•	■	■	■	•
<b>Link</b>	1	■	•	•	■	•	•	■	■	•	•	•	■	■	■	•
<b>Nitelights</b>	2	■	•	•	■	•	•	■	■	•	•	•	■	■	■	•
<b>Playground</b>	1	■	•	•	■	•	•	■	■	•	•	•	■	■	■	•
<b>Redeem</b>	3	■	•	•	■	•	•	■	■	•	•	•	■	•	■	•
<b>Remix</b>	5	■	•	•	■	•	•	■	■	•	•	•	■	■	■	•
<b>Retrieve</b>	3	■	•	•	■	•	•	■	■	•	•	•	■	•	■	•
<b>Seating Vinyl</b>	2	■	•	•	■	•	•	•	■	•	•	•	■	•	■	•
<b>Spyder</b>	2	■	•	•	■	•	•	■	■	•	•	•	■	■	■	•
<b>Stand In</b>	2	■	•	•	■	•	•	■	■	•	•	•	■	■	■	•
<b>Steelcut Trio</b>	7	■	•	•	•	•	•	■	■	•	•	•	■	■	■	•
<b>Texel</b>	3	■	•	•	■	•	•	■	■	•	•	•	■	•	•	•
<b>Zoe2</b>	2	■	•	•	■	•	•	■	■	•	•	•	■	■	■	•

Ships standard in 5-7 business days.

Tip: Brisa is available in 15 days delivered only.

Tip: Refer to Seating Surface Materials page 247 for specific Buoy offering.

### Legend

- = Not available
- = Available
- = Available with exceptions
- ▣ = COM approved
- E = Established
- ▶ See *Surface Materials* and *Specifying* pages.

**Products that are missing from the matrix are not available with these surface materials.**

# Understanding Customer's Own Material (COM)

The Customer's Own Material (COM) program allows customers to select textiles that are not offered through the standard Surface Materials program for use on turnstone products.

The COM process consists of seven steps: COM Web Site, Testing/Approval, Steelcase to Purchase Service, Pricing, Cutting Direction, Yardage Requirements, and the Purchase Orders.

## COM Web Site

- COM Web site features application test results for all COM, Designtex Graded-In, Options Collection and Classics Collection fabrics. The Web site allows you to calculate yardage requirements for most turnstone seating and systems products.
- Access the COM Web site at: [www.steelcase.com](http://www.steelcase.com). 1.888.STEELCASE (1.888.783.3522) or send an e-mail to [lineone@steelcase.com](mailto:lineone@steelcase.com).

## Application Testing/Approval

- Confirm that the selected COM has been tested and approved for application on a specific product by checking the COM Web site at: [www.steelcase.com](http://www.steelcase.com).

**COM Application Testing** or "approved for application" means the COM fabric has been reviewed for manufacturability using the standard manufacturing techniques to achieve acceptable appearance per Steelcase quality standards.

**COM fabric performance**, including durability, pilling, color fastness, stretch, splitting, fraying, etc. is not tested by Steelcase. Therefore, COMs are not covered by the Steelcase Warranty. Each COM vendor is responsible for all warranty claims related to fabric performance.

**Steelcase reserves the right** to reject or reverse any COM approval that does not meet the manufacturing requirements in actual production. COM approval may be rejected or reversed because not all application testing is based on actual production conditions and because some materials vary in fabrication.

• If the COM is approved, you may continue the order process.

• If the COM has failed, you must reselect a fabric.

• If the COM is not listed, that means Steelcase has not tested that fabric on our products.

*Helpful hint: Seating vinyl and leather do not require testing. Customer's own leather is available on Jenny Lounge seating. Customer's own vinyl is available on all seating products that accept Steelcase standard vinyl.*

• If your material has not been tested, then send yardage (4.5 yards for seating, 2 yards for vertical surfaces) and submit a completed COM Application Testing Request form to:

Steelcase Inc.  
Attn: COM Testing  
Door 305  
4060 Eastern Avenue  
Grand Rapids, MI 49508

• To ensure rapid processing, please use the electronic COM Application Testing Request form found on the COM Web site under the "How To Test" tab **or** fax a copy of the COM Testing Request form from the *Surface Materials Reference Manual* to 616.698.4700. **All information on the form is required in order to complete testing. COM tests cannot be performed if information is incomplete. Contact your requested fabric vendor for any missing information.**

• Test results will be returned (by fax or e-mail) in four working days from receipt of fabric and completed form.

COM materials that are approved for application to panel systems might require UL approval after application test approval. UL approval does involve fees and extended lead times.

All vertical surface COMs tested and approved with a content of 100% polyester meet a minimum of class C/UL1286. If class A or B fire rating is indicated, a burn test must be performed. All vertical surface COMs with a blended fabric construction require a UL burn test. For further UL information, contact a COM Consultant at 616.475.2426.

*Tip: Jenny Lounge products have a relaxed appearance. With some COMs they may show soft comfort wrinkles upon use.*

## Steelcase to Purchase Service

The COM program also includes a service to purchase approved COM for our customers for use on turnstone products. Steelcase will facilitate the ordering, scheduling and shipment of COM directly from the suppliers. There are no additional charges for this service.

**Steelcase is the only party that may purchase COM for all turnstone products.**

In some instances, not all colors in a fabric family are approved. You will be informed of these instances before Steelcase purchases the fabric.

If for some reason the fabric must be ordered directly from the supplier, contact your Steelcase Solutions Fulfillment Team Representative for approval and instructions prior to purchase. The only time the customer can purchase fabric is for testing.

## COM Pricing

- Confirm COM is tested and approved.
- Use the COM or COL (Customer's Own Leather) price group found under Surface Materials Options within each product spec guide.
- Calculate yardage required by using the COM Calculator found on the COM Web site at [www.steelcase.com](http://www.steelcase.com) 1.888.STEELCASE (1.888.783.3522) or send an e-mail to [lineone@steelcase.com](mailto:lineone@steelcase.com). *Helpful tip: Fabric width, repeat and product quantity and style number are required in order to calculate yardage accurately.*
- Add the cost of the fabric to the COM or COL price group.
- The cost of the COM will be shown as a separate line on the acknowledgement.

COM vendors require fabric purchases in half or full yard increments. Therefore, Steelcase will round all final yardage calculations to the half yard.

COL (Customer's Own Leather) is calculated by the square foot, but purchased in hide. The customer is responsible for purchasing the minimum hide requirement.

Base price of chair includes standard fabrics. Steelcase will not allow credit or deduct the cost of the standard fabric when a COM fabric is selected in its place.

Steelcase cannot be held responsible for costs incurred when a COM supplier ships a COM fabric that does not meet Steelcase application standards or for costs incurred for late deliveries when a COM supplier commits to shipping a COM fabric for manufacturing by a specific date and misses that date.

### COM Warranty

Steelcase standard warranty does not apply to Designtex or any other COM vendor's fabric.

- Designtex and other COM suppliers are responsible for color consistency within commercial tolerances, abrasion resistance, UV stability, and resistance to soiling and perspiration. These fabrics or vinyls are subject to policies regarding appearance, behavior, and durability that have been established by the fabric supplier. The customer's remedy for a fabric defect is limited to the replacement of the fabric by the supplier. Durability, performance, and fabric defects of COM fabrics are not guaranteed by Steelcase.

### Cutting Direction

#### SEATING:

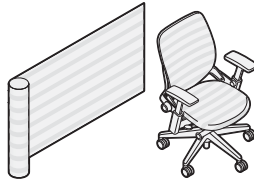

Warp horizontal



Warp vertical

- Dealers must specify fabric application direction on all COM orders.**
- COMs for seating are most often applied in the warp vertical (downroll, woven way) direction. Some exceptions include patterns with stripes, fabrics that are sampled in the warp horizontal (railroad, across roll) direction, and solid vinyls.
- ▶ See Cutting Direction Guidelines in the *Surface Materials Reference Manual* for more information.

#### VERTICAL SURFACES:

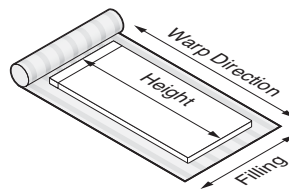

Warp vertical

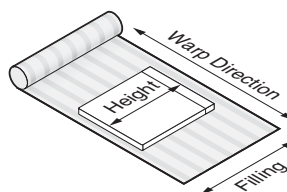

Warp horizontal

- Dealers must specify fabric application direction on all COM orders.**

- The cutting direction of COMs on vertical surfaces varies by product and sometimes by style number. Please check the COM Web site for the approved cutting direction for your particular COM.

- ▶ See Cutting Direction Guidelines in the *Surface Materials Reference Manual* for more information.

Steelcase cannot guarantee pattern repeat match from product to product. Steelcase also cannot guarantee pattern repeat match within each product listed. (i.e., seat and back, arms to back, etc.)

### COM Yardage Requirements

- For the most accurate yardage requirements, visit the Calculator found on the COM Web site or call 1.888.STEELCASE (1.888.783.3522) or send an e-mail to [lineone@steelcase.com](mailto:lineone@steelcase.com).
- The Calculator on the COM Web site provides the same yardage requirements used by Steelcase purchasing.

Yardage requirements will change depending on:

- width of fabric
- fabric repeat
- cutting direction
- product style number
- quantity of products being manufactured

- COM vinyl requires upholstery in the railroad cutting direction. Please visit our Web site or call 1.888.STEELCASE (1.888.783.3522) or send an e-mail to [lineone@steelcase.com](mailto:lineone@steelcase.com) for yardage requirements.

- Certain fabric treatments and backings require additional yardage or yardage minimums. Please contact the supplier for specific information.
- COM fabric vendors require fabric purchases in half- or full-yard increments, and the Steelcase COM calculator will automatically round all final yardage calculations to the half yard.
- Steelcase is the only party who may purchase COMs.

# Maintenance and Cleaning

**Inspecting and cleaning.** Have your chair's upholstery, finishes, controls, base, and other moving parts inspected and cleaned at least once a year.

**Cleaning painted and plastic surfaces.** Finishes should be cleaned with water and/or a non-abrasive cleaner (such as Formula 409® and Fantastik®).

**Maintaining upholstery.** Use a vacuum cleaner for regular cleaning. Periodic professional dry cleaning is recommended. Do not steam clean.

**Removing excess stains or heavy soil.** Soak up excess stain with a cloth. Do not dry the stain completely or it may set. For most water-soluble stains (coffee, fruit juice, washable ink), use an upholstery cleaning solution (such as Bissell® upholstery shampoo or Guardsman Fabri-Kleen® products) and follow directions on package. For oil-borne stains, use a dry cleaning solution at room temperature (never hot) and let solution work into the stain. Use quick, light strokes to brush the stain with a soft bristle brush. Work from outside toward the center to prevent rings. Soak up remaining dry cleaning solution, then sponge the fabric with cool water. Let fabric dry completely; then vacuum thoroughly. If stain is still visible, repeat procedure. Several light applications of cleaning solution are more effective and less damaging than one heavy application.

Formula 409 is a registered trademark of Clorox company. Fantastik is a registered trademark of Dow Consumer Products, Inc. Fabri-Kleen is a registered trademark of Guardsman Chemical. All other marks are marks of their respective owners.

---

# Resources



## Lock and Keying Options

Tour and Campfire

**328**

## Style Number Index

**330**

# Lock and Keying Options

Tour and Campfire

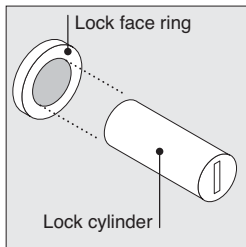

**Front-removable lock cylinders** can be installed or removed in the field with a special tool. This feature allows you to field install lock cylinders after the furniture is installed.

**All locks** are designated with key numbers. You can specify a key number; however, if you don't specify a key number, the locks in your order will be keyed random.

**Two types** of locks are available — the standard keying system (FR series) and the master keying system (XF series). All the locks in the XF series can be opened with a single master key.

## Standard Keying

**All products** are standard keyed random.

### Step 1

**Furniture will be shipped with a plastic shipping plug.** Specify lock cylinder and keying options separately. Only products with factory-installed lock mechanisms can accept lock cylinders in the field.

*Tip: Be sure to specify a lock color number (9201 Polished Chrome or 9250 Ember Chrome) for the lock face ring.*

### Step 2

**Order enough lock cylinders** to fill each lock location. You must also order a lock tool.

*Tip: Lock tools are reusable. You don't need to order additional lock tools with every furniture order.*

Lock cylinders and the installation tool will be shipped separately so that you can install the locks when you are ready.

**To specify lock cylinders,** list the total number of lock cylinders that you want with the appropriate style number. If you are specifying key numbers, list the breakdown of the quantity of each key number.

**An example** of how your order should look is shown below:

Example:

10 LOCK9201FR FR320  
5 LOCK9201FR FR350  
15 LOCK9201XF XF1100  
30 Total

1 877102003SR standard lock tool  
1 877102002SR master lock tool

## Keying Options

**Key random** means that the locks will be assigned arbitrarily at the factory with key numbers ranging from FR305 to FR454.

*Tip: Random keying can mean that different furniture units will have the same key number. If you must have all locks keyed differently, you should specify key numbers for all locks.*

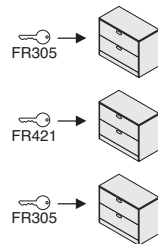

**Key specific** means that you can specify any key number from FR305 to FR454. This option can be used to key all the furniture units in a workstation or department the same.

*Tip: Designate the quantity per key number in your specification when ordering more than one product with the same style number.*

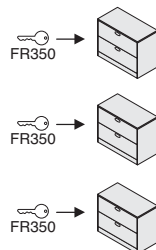

**Key consecutive** means that you can specify lock numbers in a consecutive order to ensure that no two locks have the same key number until the key sequence repeats. You must select a beginning key number from FR305 to FR454.

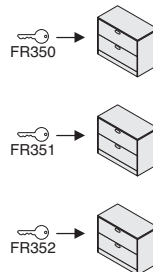

**Master key consecutive** means that you can specify lock numbers in a consecutive order to ensure that no two locks have the same key number until the key sequence repeats. You must select a beginning key number from XF1001 to XF1150. All the locks in the XF series can be opened with a master key.

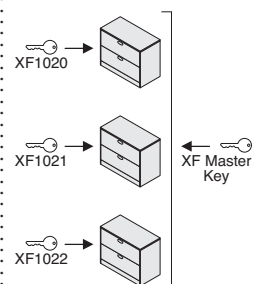

**Master key random** means that the locks will be assigned arbitrarily at the factory with key numbers ranging from XF1001 to XF1150. All XF locks can be opened with a master key.

*Tip: Random keying can mean that different furniture units will have the same key number. If you must have all locks keyed differently, you should specify key numbers for all locks.*

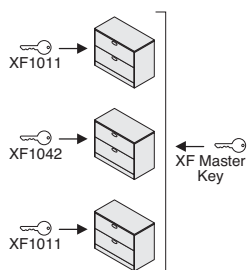

**Master key specific** means that you can specify any key number from XF1001 to XF1150. All the locks in the XF series can be opened with a master key.

*Tip: Designate the quantity per key number in your specification when ordering more than one product with the same style number.*

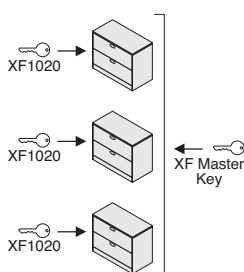

## Lock Cylinders

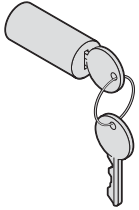

Tip: Lock price is included in price of furniture with locks.

Tip: For replacement lock cylinders, refer to Service Parts.

Tip: You can change lock cylinders in the field by using the appropriate lock tool.

Standard Includes	Required to Specify
-------------------	---------------------

- |  |  |
|--|--|
| <ul style="list-style-type: none"> <li>Lock cylinder, keyed random: 9201 Polished Chrome or 9250 Ember Chrome</li> <li>Two keys</li> </ul> | <ul style="list-style-type: none"> <li>1 Style number</li> <li>2 Options, if selected (see below)</li> </ul> |
|--|--|

Options	U.S. Price	Required to Specify
<b>Key specific</b>	No cost	Select key number from FR305–FR454.
<b>Key consecutive</b>	No cost	Specify <i>key consecutive</i> and must select beginning key number from FR305–FR454.
<b>Master key random</b>	+\$23 each	Specify <i>master key random</i> .
<b>Master key specific</b>	+\$23 each	Specify key number from XF1001–XF1150.
<b>Master key consecutive</b>	+\$23 each	Specify <i>master key consecutive</i> and must select beginning key number from XF1001–XF1150.

### Specification Information

Color	Style Number	U.S. Price
-------	--------------	------------

### FR Series (Standard Keying System) – Lock Cylinder

Polished Chrome	<b>LOCK9201FR</b>	No cost
Ember Chrome	<b>LOCK9250FR</b>	No cost

### Standard Lock Tool

	<b>877102003SR</b>	\$23
--	--------------------	------

### XF Series (Master Keying System) – Lock Cylinder

Polished Chrome	<b>LOCK9201XF</b>	No additional cost. Price included in price of furniture with master-keyed locks.
Ember Chrome	<b>LOCK9250XF</b>	No additional cost. Price included in price of furniture with master-keyed locks.

### Master Lock Tool

	<b>877102002SR</b>	\$23
--	--------------------	------



**For Canadian Pricing**  
 Multiply U.S. Price by the Canadian price factor.  
 ▶ See page 1 for details.

# Style Number Index

Style Number	Page	Description
<b>877102002SR</b>	329	Master Lock Tool
<b>877102003SR</b>	329	Standard Lock Tool
<b>A5LQ58235823U</b>	304	Details Hgt-Adj Table Wksf
<b>A5RQ582323U</b>	304	Details Hgt-Adj Table Wksf
<b>CDFIS14</b>	296	Freestanding In-Line Document Support
<b>CF800</b>	300	CF Series Flat Pnl Monitor Arm, Standard
<b>CFDHA</b>	301	CF Series Flat Pnl Monitor Pole Mount, Dbl
<b>CFSHA</b>	301	CF Series Flat Pnl Monitor Pole Mount, Sgl
<b>CFSPC</b>	302	CF Series Flat Pnl Monitor Brkt
<b>CFSPTM</b>	302	CF Series Flat Pnl Monitor Brkt
<b>CFTR</b>	296	Adjustable Foot Rest
<b>CPRCCN</b>	296	Vertical Non-Locking CPU Cradle
<b>CPRSL</b>	297	Vert Processor Sling, Freestanding
<b>DSCW20</b>	285	SOTO Cableway
<b>DSCW30</b>	285	SOTO Cableway
<b>DSDFB</b>	289	SOTO Diagonal File Box
<b>DSLEDF</b>	291	SOTO LED Task Light, Freestanding
<b>DSLEDR</b>	291	SOTO LED Task Light, Rail-Mount
<b>DSLLB</b>	288	SOTO Landscape Letter Box
<b>DSPB</b>	290	SOTO Personal Box
<b>DSR28</b>	283	28" SOTO Rail
<b>DSR34</b>	283	34" SOTO Rail
<b>DSR40</b>	283	40" SOTO Rail
<b>DSR46</b>	283	46" SOTO Rail
<b>DSR52</b>	283	52" SOTO Rail
<b>DSR58</b>	283	58" SOTO Rail
<b>DSR64</b>	283	64" SOTO Rail
<b>DSRT52</b>	106, 127, 284	52" SOTO Tour Rail
<b>DSRT58</b>	106, 127, 284	58" SOTO Tour Rail
<b>DSRT64</b>	106, 127, 284	64" SOTO Tour Rail
<b>DSSA1410</b>	287	SOTO Shelf
<b>DSSA1410H</b>	287	SOTO Shelf
<b>DSSA143</b>	287	SOTO Shelf
<b>DSSA143H</b>	287	SOTO Shelf
<b>DSSA146</b>	287	SOTO Shelf
<b>DSSA146H</b>	287	SOTO Shelf
<b>DSSA2410</b>	286	SOTO Shelf
<b>DSSA2410H</b>	286	SOTO Shelf
<b>DSSA246</b>	286	SOTO Shelf
<b>DSSA246H</b>	286	SOTO Shelf
<b>DSSA363</b>	286	SOTO Shelf
<b>DSSA363H</b>	286	SOTO Shelf
<b>DSSB</b>	290	SOTO Storage Box Shelf Set of 3
<b>DSSPB</b>	288	SOTO Pile Box
<b>DSTB</b>	288	SOTO Tool Box
<b>DSUB</b>	289	SOTO Utility Box
<b>FPAEC1BIVI</b>	62, 298	Eyesite Sgl Display Support, Ext Crank Adj
<b>FPAEC2BIVI</b>	62, 298	Eyesite Dual Display Support, Ext Crank Adj
<b>FPAELC1BIVI</b>	62, 299	Eyesite Flat Pnl Mon Arm w/Sgl Lptp Sprt
<b>FPAELC2BIVI</b>	63, 299	Eyesite Flat Pnl Mon Arm w/Dual Lptp Sprt
<b>FPASINGLECC</b>	303	FYI C-clamp Mounting Brkt
<b>FPCBIVI</b>	63, 300	Eyesite Mounting Brkt, Bivi
<b>FTH</b>	282	Flat Top Hanger
<b>L52319MLGG</b>	294	5" Lift & Lock KB Assy, 19" Pltfrm
<b>L52319MRGG</b>	294	5" Lift & Lock KB Assy, 19" Pltfrm

Style Number	Page	Description
<b>L523EN10GG</b>	295	5" Lift & Lock KB Assy, Enviro Pltfrm
<b>L72619MLGG</b>	294	7" Lift & Lock KB Assy, 19" Pltfrm
<b>L72619MRGG</b>	294	7" Lift & Lock KB Assy, 19" Pltfrm
<b>L726EN10GG</b>	295	7" Lift & Lock KB Assy, Enviro Pltfrm
<b>LMINILED</b>	126, 291	Mini SOTO LED Light
<b>LOCK9201FR</b>	329	Lock Cylinder
<b>LOCK9201XF</b>	329	Lock Cylinder
<b>LOCK9250FR</b>	329	Lock Cylinder
<b>LOCK9250XF</b>	329	Lock Cylinder
<b>LPTL30</b>	148	LED Personal Task Light
<b>LPTL30NR</b>	148	LED Personal Task Light
<b>LT2</b>	126	Underline Light
<b>LT2CHI</b>	126	Underline Light
<b>QACPUT</b>	297	CPU Trolley
<b>SE23JP10SF</b>	292	Stella Ext KB Assy, Jules Pltfrm
<b>SE23SL10SA</b>	292	Stella Ext KB Assy, Slider Pltfrm
<b>SS20JP10SF</b>	292	Stella Std KB Assy, Jules Pltfrm
<b>SS20SL10SA</b>	292	Stella Std KB Assy, Slider Pltfrm
<b>TS2ACMH2</b>	59	Bivi Hook
<b>TS2ACMH4</b>	59	Bivi Hook
<b>TS2ACMS</b>	59	Bivi Top Shelf
<b>TS2ACTH</b>	59	Bivi Bottom Shelf
<b>TS2ARCHBH</b>	53	Bivi Bike Hook Arch Mount
<b>TS2ARCHBR</b>	54	Bivi Canopy
<b>TS2ARCHC</b>	54	Bivi Canopy
<b>TS2ARCHL</b>	51	Bivi Short Arch
<b>TS2ARCHMM</b>	52	Bivi Monitor Mount
<b>TS2ARCHSIDE</b>	52	Bivi Side Storage
<b>TS2ARCHT</b>	51	Bivi Tall Arch
<b>TS2CTEC</b>	61	Bivi Trough End Cover
<b>TS2CTFC</b>	61	Bivi Trough Floor Cover
<b>TS2HOLDER</b>	54	Bivi Holder
<b>TS2LEGCVR</b>	61	Bivi Leg Cover
<b>TS2MB14</b>	53	Bivi Markerboard
<b>TS2MB30</b>	53	Bivi Markerboard
<b>TS2ORGANIZE</b>	60	Bivi Organizer
<b>TS2P260</b>	48	Bivi Hardwired Powerway
<b>TS2P2CHI</b>	48	Bivi Hardwired Powerway
<b>TS2PBT2</b>	47	Bivi Accessory Base Power-In
<b>TS2PBT2SF</b>	47	Bivi Accessory Base Power-In
<b>TS2PLANTER</b>	54	Bivi Planter
<b>TS2PS1PK</b>	46	Bivi Plug and Play Power Kit
<b>TS2PS2PK</b>	46	Bivi Plug and Play Power Kit
<b>TS2PS4PK</b>	47	Bivi Plug and Play Power Kit
<b>TS2PT2T</b>	49	Bivi Table-to-Table Power Connector
<b>TS2RPBSL</b>	58	Bivi Leg
<b>TS2RPCT</b>	58	Bivi Cable Trough
<b>TS2RPCT48</b>	58	Bivi Cable Trough
<b>TS2RPFWS</b>	57	Bivi Table Top
<b>TS2RPFWS48</b>	57	Bivi Table Top
<b>TS2RPSWS</b>	57	Bivi Table Top with Back Pocket
<b>TS2RPTC</b>	58	Bivi Pocket Cover
<b>TS2RW</b>	57	Bivi Half-Round Table Top
<b>TS2SCREEN</b>	60	Bivi Screen
<b>TS2SDAF3048</b>	38	Bivi Table Plus One

Style Number	Page	Description	Style Number	Page	Description
<b>TS2SDAF3060</b>	38	Bivi Table Plus One	<b>TS31404CH</b>	222	Jenny Chair
<b>TS2SDAS3060</b>	40	Bivi Table Plus One with Back Pocket	<b>TS31404CT</b>	222	Jenny Chair
<b>TS2SDWF3048</b>	37	Bivi Table for One	<b>TS31404H</b>	222	Jenny Chair
<b>TS2SDWF3060</b>	37	Bivi Table for One	<b>TS31404T</b>	222	Jenny Chair
<b>TS2SDWS3060</b>	39	Bivi Table for One with Back Pocket	<b>TS31405</b>	233	Jenny Ottoman
<b>TS2ST1H1460</b>	50	Bivi Depot	<b>TS31405C</b>	233	Jenny Ottoman
<b>TS2ST2H2860</b>	50	Bivi Big Depot	<b>TS31406</b>	225	Jenny Chair
<b>TS2ST2H4260</b>	50	Bivi Bigger Depot	<b>TS31406C</b>	225	Jenny Chair
<b>TS2STEH1660</b>	50	Bivi Trunk	<b>TS31407</b>	227	Jenny Chair
<b>TS2TTAF3048</b>	42	Bivi Table Plus Two	<b>TS31407C</b>	227	Jenny Chair
<b>TS2TTAF3060</b>	42	Bivi Table Plus Two	<b>TS31408</b>	231	Jenny Chair
<b>TS2TTAS3060</b>	44	Bivi Table Plus Two with Back Pockets	<b>TS31409</b>	229	Jenny Chair
<b>TS2TTWF3048</b>	41	Bivi Table for Two	<b>TS31410</b>	233, 246	alight Ganging Kit
<b>TS2TTWF3060</b>	41	Bivi Table for Two	<b>TS31415H</b>	234, 261	Jenny Occasional Table
<b>TS2TTWS3060</b>	43	Bivi Table for Two with Back Pockets	<b>TS31415L</b>	234, 261	Jenny Occasional Table
<b>TS2WALLBH</b>	53	Bivi Bike Hook Wall Mount	<b>TS31416H</b>	234, 261	Jenny Occasional Table
<b>TS30301</b>	178	Jack Task Chair	<b>TS31416L</b>	234, 261	Jenny Occasional Table
<b>TS30302</b>	178	Jack Task Chair	<b>TS31426</b>	225	Jenny Chair
<b>TS30303</b>	180	Jack Task Chair	<b>TS31426C</b>	225	Jenny Chair
<b>TS30304</b>	180	Jack Task Chair	<b>TS31428</b>	231	Jenny Chair
<b>TS30305</b>	179	Jack Task Chair	<b>TS31438</b>	231	Jenny Chair
<b>TS30311</b>	178	Jack Task Chair	<b>TS31601</b>	240	Lincoln Lounge
<b>TS30312</b>	178	Jack Task Chair	<b>TS34401</b>	155, 245	alight Lounge Ottoman
<b>TS30313</b>	180	Jack Task Chair	<b>TS34402</b>	245	alight Corner Ottoman
<b>TS30314</b>	180	Jack Task Chair	<b>TS34403</b>	245	alight Bench Ottoman
<b>TS30315</b>	179	Jack Task Chair	<b>TS34410T</b>	246, 262	alight End Table
<b>TS30321</b>	178	Jack Task Chair	<b>TS34411T</b>	246, 262	alight Coffee Table
<b>TS30322</b>	178	Jack Task Chair	<b>TS39150</b>	260	Sweeper Martini Table
<b>TS30323</b>	180	Jack Task Chair	<b>TS3BC</b>	152	Campfire Big Lounge
<b>TS30324</b>	180	Jack Task Chair	<b>TS3FR</b>	157	Footrest
<b>TS30325</b>	179	Jack Task Chair	<b>TS3HL</b>	153	Campfire Half Lounge
<b>TS30701</b>	208	Scoop Stool	<b>TS3RS</b>	55	Bivi Rumble Seat
<b>TS30702</b>	208	Scoop Stool	<b>TS3RSBKT</b>	55	Bivi Rumble Seat with Exposed Bracket
<b>TS30703</b>	209	Scoop Side Chair	<b>TS3RSH</b>	56	Bivi Hoodie
<b>TS30704</b>	209	Scoop Side Chair	<b>TS3RSL2</b>	55	Bivi Rumble Seat Support
<b>TS311EXP</b>	203	Uno Select Mid-Back Multi-Purpose Chair	<b>TS3RSTA</b>	55	Bivi Rumble Seat Support
<b>TS31201A</b>	190	Shortcut Chair	<b>TS3WG</b>	154	Campfire Wedge
<b>TS31202B</b>	191	Shortcut Stool	<b>TS434EXP</b>	198	cobi Select
<b>TS31203</b>	192	Shortcut Cushion	<b>TS466EXP</b>	172	Reply Select
<b>TS31401</b>	217	Jenny Chair	<b>TS4L27PG</b>	113	Groupwork Post Leg
<b>TS31401C</b>	217	Jenny Chair	<b>TS4LSHPG</b>	113	Groupwork Post Leg
<b>TS31401CH</b>	217	Jenny Chair	<b>TS4TBL</b>	146	Campfire Big Lamp
<b>TS31401CT</b>	217	Jenny Chair	<b>TS4TL28</b>	142	Campfire Big Table
<b>TS31401H</b>	217	Jenny Chair	<b>TS4TL40</b>	142	Campfire Big Table
<b>TS31401T</b>	217	Jenny Chair	<b>TS4TLDRW</b>	144	Campfire Table Drawer
<b>TS31402</b>	219	Jenny Chair	<b>TS4TLT28</b>	143	Campfire Big Table with Trough
<b>TS31402C</b>	219	Jenny Chair	<b>TS4TLT40</b>	143	Campfire Big Table with Trough
<b>TS31403</b>	222	Jenny Chair	<b>TS4TPST</b>	156	Slim Table
<b>TS31403C</b>	222	Jenny Chair	<b>TS4TPT</b>	149	Campfire Paper Table
<b>TS31403CH</b>	222	Jenny Chair	<b>TS4TPTG</b>	150	Campfire Glass
<b>TS31403CT</b>	222	Jenny Chair	<b>TS4TPTP</b>	149	Campfire Paper
<b>TS31403H</b>	222	Jenny Chair	<b>TS4TPWR</b>	158	Campfire Receptacle
<b>TS31403T</b>	222	Jenny Chair	<b>TS4TPWR1</b>	158	Campfire Receptacle
<b>TS31404</b>	222	Jenny Chair	<b>TS4TPWRD</b>	158	Campfire Receptacle
<b>TS31404C</b>	222	Jenny Chair	<b>TS4TPWRD1</b>	158	Campfire Receptacle

Style Number Index, continued

Style Number	Page	Description
<b>TS4TRAIL</b>	144	Campfire Center Rail
<b>TS4TSCRNL</b>	151	Campfire Screen
<b>TS4TSCRNR</b>	151	Campfire Screen
<b>TS4TSLH</b>	145	Campfire Storage Cabinet
<b>TS4TSRH</b>	145	Campfire Storage Cabinet
<b>TS4TST</b>	157	Skate Table
<b>TS4TSWLH</b>	145	Campfire Storage Cabinet Wardrobe
<b>TS4TSWRH</b>	145	Campfire Storage Cabinet Wardrobe
<b>TS4TVWM28</b>	158	Campfire Cord Cover
<b>TS4TVWM40</b>	158	Campfire Cord Cover
<b>TS4TWP</b>	147	Campfire Personal Table
<b>TS4W2448</b>	258	Simple Rectangular Table
<b>TS4W3060</b>	258	Simple Rectangular Table
<b>TS4W4242</b>	258	Simple Square Table
<b>TS4WCAFE3030</b>	259	Simple Square-Up Table
<b>TS4WCAFERND30</b>	259	Simple Stand-Up Table
<b>TS4WLNGE</b>	259	Simple Lounge Table
<b>TS4WRND42</b>	258	turnstone Round Table
<b>TS5GF3</b>	114	Flip Grommet
<b>TS5LEGCLP</b>	257	Under Worksurface Wire Clips
<b>TS5SKEXT</b>	257	Under Worksurface Skel Wire Manager
<b>TS5SKLBNE</b>	257	Under Worksurface Skel Wire Manager
<b>TS5YMB212</b>	256	Screen Bracket
<b>TS5YMB218</b>	256	Screen Bracket
<b>TS5YMB312</b>	256	Screen Bracket
<b>TS5YMB318</b>	256	Screen Bracket
<b>TS5YMBADP</b>	256	Screen Adapter
<b>TS5YSL1218</b>	255	Slatwall Screen
<b>TS5YSL1226</b>	255	Slatwall Screen
<b>TS5YSL1230</b>	255	Slatwall Screen
<b>TS5YSL1236</b>	255	Slatwall Screen
<b>TS5YSL1244</b>	255	Slatwall Screen
<b>TS5YSL1260</b>	255	Slatwall Screen
<b>TS5YTS1218</b>	255	Desk-mounted Screen
<b>TS5YTS1227</b>	255	Desk-mounted Screen
<b>TS5YTS1230</b>	255	Desk-mounted Screen
<b>TS5YTS1236</b>	255	Desk-mounted Screen
<b>TS5YTS1244</b>	255	Desk-mounted Screen
<b>TS5YTS1260</b>	255	Desk-mounted Screen
<b>TS5YTS1818</b>	255	Desk-mounted Screen
<b>TS5YTS1827</b>	255	Desk-mounted Screen
<b>TS5YTS1830</b>	255	Desk-mounted Screen
<b>TS5YTS1836</b>	255	Desk-mounted Screen
<b>TS5YTS1844</b>	255	Desk-mounted Screen
<b>TS5YTS1860</b>	255	Desk-mounted Screen
<b>TSATRC39</b>	114	Reinforcing Channel
<b>TSATRC48</b>	114	Reinforcing Channel
<b>TSATRC57</b>	114	Reinforcing Channel
<b>TSATRC72</b>	114	Reinforcing Channel
<b>TSBUOYBLACK</b>	184	Buoy
<b>TSBUOYBLUE</b>	184	Buoy
<b>TSBUOYGREEN</b>	184	Buoy
<b>TSBUOYGREY</b>	184	Buoy
<b>TSBUOYRED</b>	184	Buoy
<b>TSBUOYWHITE</b>	184	Buoy

Style Number	Page	Description
<b>TSTECB</b>	102	Tour Wksf-Mntd Power and Data
<b>TSTECBDP</b>	105	Bench Screen
<b>TSTECBT</b>	105	Bench Trough
<b>TSTECC30</b>	103	Vertical Cord Cover
<b>TSTECC42</b>	103	Vertical Cord Cover
<b>TSTECLAMP</b>	102	Tour Wksf-Mntd Power and Data
<b>TSTECM</b>	101	Horizontal Cord Manager
<b>TSTEGC</b>	104	Tour Vertical Cord Cover Grommet Insert
<b>TSTEP172</b>	94	Tour Electrical Component
<b>TSTEP272</b>	94	Tour Electrical Component
<b>TSTEP2C069</b>	96	Tour Electrical Component
<b>TSTEP2C075</b>	96	Tour Electrical Component
<b>TSTEP2C081</b>	96	Tour Electrical Component
<b>TSTEP2C087</b>	96	Tour Electrical Component
<b>TSTEP2C093</b>	96	Tour Electrical Component
<b>TSTEP2C099</b>	96	Tour Electrical Component
<b>TSTEP2C105</b>	96	Tour Electrical Component
<b>TSTEP2C111</b>	96	Tour Electrical Component
<b>TSTEP2C117</b>	96	Tour Electrical Component
<b>TSTEP2C120</b>	96	Tour Electrical Component
<b>TSTEP2C123</b>	96	Tour Electrical Component
<b>TSTEP2C126</b>	96	Tour Electrical Component
<b>TSTEP2C129</b>	96	Tour Electrical Component
<b>TSTEP2C132</b>	96	Tour Electrical Component
<b>TSTEP2C135</b>	96	Tour Electrical Component
<b>TSTEP2C138</b>	96	Tour Electrical Component
<b>TSTEP2C141</b>	96	Tour Electrical Component
<b>TSTEP2C144</b>	96	Tour Electrical Component
<b>TSTEP2C147</b>	96	Tour Electrical Component
<b>TSTEP2C150</b>	96	Tour Electrical Component
<b>TSTEP2C153</b>	96	Tour Electrical Component
<b>TSTEP2C156</b>	96	Tour Electrical Component
<b>TSTEP2C159</b>	96	Tour Electrical Component
<b>TSTEP2C162</b>	96	Tour Electrical Component
<b>TSTEP2C165</b>	96	Tour Electrical Component
<b>TSTEP2C168</b>	96	Tour Electrical Component
<b>TSTEP2C171</b>	96	Tour Electrical Component
<b>TSTEP2C174</b>	96	Tour Electrical Component
<b>TSTEP2C177</b>	97	Tour Electrical Component
<b>TSTEP2C180</b>	97	Tour Electrical Component
<b>TSTEP2C183</b>	97	Tour Electrical Component
<b>TSTEP2C186</b>	97	Tour Electrical Component
<b>TSTEP2C189</b>	97	Tour Electrical Component
<b>TSTEP2C192</b>	97	Tour Electrical Component
<b>TSTEP2C195</b>	97	Tour Electrical Component
<b>TSTEP2C198</b>	97	Tour Electrical Component
<b>TSTEP2C201</b>	97	Tour Electrical Component
<b>TSTEP2C204</b>	97	Tour Electrical Component
<b>TSTEP2C207</b>	97	Tour Electrical Component
<b>TSTEP2C210</b>	97	Tour Electrical Component
<b>TSTEP2C213</b>	97	Tour Electrical Component
<b>TSTEP2C216</b>	97	Tour Electrical Component
<b>TSTEP2C219</b>	97	Tour Electrical Component
<b>TSTEP2C222</b>	97	Tour Electrical Component
<b>TSTEP2C225</b>	97	Tour Electrical Component

Style Number	Page	Description	Style Number	Page	Description
<b>TSTEP2C228</b>	97	Tour Electrical Component	<b>TSTEPBT442SF</b>	93	Base Power-In
<b>TSTEP472</b>	94	Tour Electrical Component	<b>TSTEP2C</b>	95	Tour Electrical Component
<b>TSTEP4C096</b>	98	Tour Electrical Component	<b>TSTEP2C4</b>	95	Tour Electrical Component
<b>TSTEP4C102</b>	98	Tour Electrical Component	<b>TSTERDW</b>	100	Tour Communication Module Pkg
<b>TSTEP4C108</b>	98	Tour Electrical Component	<b>TSTERPDWD</b>	101	Tour Wksf-Mntd Power and Comm Sph
<b>TSTEP4C114</b>	98	Tour Electrical Component	<b>TSTERPDWR</b>	103	Tour Wksf-Mntd Retractable Pwr and Data
<b>TSTEP4C120</b>	98	Tour Electrical Component	<b>TSTERPW</b>	100	Tour Receptacle Pkg
<b>TSTEP4C126</b>	98	Tour Electrical Component	<b>TSTLATPAD</b>	123	Lateral File Cushion
<b>TSTEP4C132</b>	98	Tour Electrical Component	<b>TSTM3072</b>	90	Counter
<b>TSTEP4C138</b>	98	Tour Electrical Component	<b>TSTM4272</b>	90	Counter
<b>TSTEP4C144</b>	98	Tour Electrical Component	<b>TSTMCT1818</b>	91	Countertop
<b>TSTEP4C147</b>	98	Tour Electrical Component	<b>TSTMCT1836</b>	91	Countertop
<b>TSTEP4C150</b>	98	Tour Electrical Component	<b>TSTMCT1854</b>	91	Countertop
<b>TSTEP4C153</b>	98	Tour Electrical Component	<b>TSTMCT1872</b>	91	Countertop
<b>TSTEP4C156</b>	98	Tour Electrical Component	<b>TSTMCTN1818</b>	91	Countertop
<b>TSTEP4C159</b>	98	Tour Electrical Component	<b>TSTMCTN1836</b>	91	Countertop
<b>TSTEP4C162</b>	98	Tour Electrical Component	<b>TSTMCTN1854</b>	91	Countertop
<b>TSTEP4C165</b>	98	Tour Electrical Component	<b>TSTMCTN1872</b>	91	Countertop
<b>TSTEP4C168</b>	98	Tour Electrical Component	<b>TSTMHF0970</b>	115	Tour Shelf
<b>TSTEP4C171</b>	98	Tour Electrical Component	<b>TSTMHF2170</b>	115	Tour Shelf
<b>TSTEP4C174</b>	98	Tour Electrical Component	<b>TSTMHF3370</b>	115	Tour Shelf
<b>TSTEP4C177</b>	98	Tour Electrical Component	<b>TSTMHF4570L</b>	115	Tour Shelf
<b>TSTEP4C180</b>	98	Tour Electrical Component	<b>TSTMHF4570R</b>	115	Tour Shelf
<b>TSTEP4C183</b>	98	Tour Electrical Component	<b>TSTMLF0970</b>	115	Tour Shelf
<b>TSTEP4C186</b>	98	Tour Electrical Component	<b>TSTMLF2170</b>	115	Tour Shelf
<b>TSTEP4C189</b>	98	Tour Electrical Component	<b>TSTMLF3370</b>	115	Tour Shelf
<b>TSTEP4C192</b>	98	Tour Electrical Component	<b>TSTMLF4570L</b>	115	Tour Shelf
<b>TSTEP4C195</b>	98	Tour Electrical Component	<b>TSTMLF4570R</b>	115	Tour Shelf
<b>TSTEP4C198</b>	98	Tour Electrical Component	<b>TSTPB120</b>	118	Screen Connector
<b>TSTEP4C201</b>	99	Tour Electrical Component	<b>TSTPB120Y</b>	118	Screen Connector
<b>TSTEP4C204</b>	99	Tour Electrical Component	<b>TSTPBCOH2</b>	118	Screen Connector
<b>TSTEP4C207</b>	99	Tour Electrical Component	<b>TSTPBCOH3</b>	118	Screen Connector
<b>TSTEP4C210</b>	99	Tour Electrical Component	<b>TSTPBSH2</b>	118	Screen Connector
<b>TSTEP4C213</b>	99	Tour Electrical Component	<b>TSTPBSH3</b>	118	Screen Connector
<b>TSTEP4C216</b>	99	Tour Electrical Component	<b>TSTPBWT</b>	118	Screen Connector
<b>TSTEP4C219</b>	99	Tour Electrical Component	<b>TSTPL3024</b>	117	Screen
<b>TSTEP4C222</b>	99	Tour Electrical Component	<b>TSTPL3030</b>	117	Screen
<b>TSTEP4C225</b>	99	Tour Electrical Component	<b>TSTPL3036</b>	117	Screen
<b>TSTEP4C228</b>	99	Tour Electrical Component	<b>TSTPL3042</b>	117	Screen
<b>TSTEP4C231</b>	99	Tour Electrical Component	<b>TSTPL3048</b>	117	Screen
<b>TSTEP4C234</b>	99	Tour Electrical Component	<b>TSTPL4224</b>	117	Screen
<b>TSTEP4C237</b>	99	Tour Electrical Component	<b>TSTPL4230</b>	117	Screen
<b>TSTEP4C240</b>	99	Tour Electrical Component	<b>TSTPL4236</b>	117	Screen
<b>TSTEP4C243</b>	99	Tour Electrical Component	<b>TSTPL4242</b>	117	Screen
<b>TSTEP4C246</b>	99	Tour Electrical Component	<b>TSTPL4248</b>	117	Screen
<b>TSTEP4C249</b>	99	Tour Electrical Component	<b>TSTPL4824</b>	117	Screen
<b>TSTEP4C252</b>	99	Tour Electrical Component	<b>TSTPL4830</b>	117	Screen
<b>TSTEP4C255</b>	99	Tour Electrical Component	<b>TSTPL4836</b>	117	Screen
<b>TSTEPBR130</b>	92	Tour Electrical Component	<b>TSTPL4842</b>	117	Screen
<b>TSTEPBR142</b>	92	Tour Electrical Component	<b>TSTPL4848</b>	117	Screen
<b>TSTEPBT2</b>	92	Tour Electrical Component	<b>TSTPL6024</b>	117	Screen
<b>TSTEPBT230SF</b>	92	Base Power-In	<b>TSTPL6030</b>	117	Screen
<b>TSTEPBT242SF</b>	92	Base Power-In	<b>TSTPL6036</b>	117	Screen
<b>TSTEPBT4</b>	93	Tour Electrical Component	<b>TSTPL6042</b>	117	Screen
<b>TSTEPBT430SF</b>	93	Base Power-In	<b>TSTPL6048</b>	117	Screen

Style Number Index, continued

Style Number	Page	Description
<b>TSTSBP1818</b>	121	Bookcase
<b>TSTSBS3618</b>	121	Bookcase
<b>TSTSCHV36</b>	119	HV Cabinet
<b>TSTSCHVD36</b>	120	Shared Environmental HV Cabinet
<b>TSTSFL1518</b>	122	My File
<b>TSTSFL1536</b>	122	My File
<b>TSTSFP4236</b>	124	Pile File
<b>TSTSMB1818</b>	125	Magnetic Markerboard
<b>TSTSMB3618</b>	125	Magnetic Markerboard
<b>TSTSMT0322</b>	125	Magnetic Tackboard
<b>TSTSMT1818</b>	125	Magnetic Tackboard
<b>TSTSMT3618</b>	125	Magnetic Tackboard
<b>TSTT27M</b>	113	Post Leg
<b>TSTT27M4</b>	113	Post Leg
<b>TSTTF1518</b>	112	Worksurface Support
<b>TSTTF2724</b>	112	Worksurface Support
<b>TSTTF2730</b>	112	Worksurface Support
<b>TSTTL2724</b>	112	Worksurface Support
<b>TSTTL2730</b>	112	Worksurface Support
<b>TSTTPC2W</b>	114	Worksurface Support
<b>TSTTPF2W</b>	114	Worksurface Support
<b>TSTTPS2W</b>	114	Worksurface Support
<b>TSTTT27</b>	113	Worksurface Support
<b>TSTTT39</b>	113	Worksurface Support
<b>TSTTTZD</b>	114	Worksurface Support
<b>TSTWHDR30</b>	110	Tour Worksurface
<b>TSTWHDR36</b>	110	Tour Worksurface
<b>TSTWHR1842</b>	107	Tour Worksurface
<b>TSTWHR1848</b>	107	Tour Worksurface
<b>TSTWHR1854</b>	107	Tour Worksurface
<b>TSTWHR2436</b>	107	Tour Worksurface
<b>TSTWHR2442</b>	107	Tour Worksurface
<b>TSTWHR2448</b>	107	Tour Worksurface
<b>TSTWHR2454</b>	107	Tour Worksurface
<b>TSTWHR2460</b>	107	Tour Worksurface
<b>TSTWHR2466</b>	107	Tour Worksurface
<b>TSTWHR2472</b>	107	Tour Worksurface
<b>TSTWHR3060</b>	107	Tour Worksurface
<b>TSTWHR3066</b>	107	Tour Worksurface
<b>TSTWHR3072</b>	107	Tour Worksurface
<b>TSTWHT2348</b>	108	Tour Worksurface
<b>TSTWHT2354</b>	108	Tour Worksurface
<b>TSTWHT2360</b>	108	Tour Worksurface
<b>TSTWHT2366</b>	108	Tour Worksurface
<b>TSTWHT2372</b>	108	Tour Worksurface
<b>TSTWHT3248</b>	108	Tour Worksurface
<b>TSTWHT3254</b>	108	Tour Worksurface
<b>TSTWHT3260</b>	108	Tour Worksurface
<b>TSTWHT3266</b>	108	Tour Worksurface
<b>TSTWHT3272</b>	108	Tour Worksurface
<b>TSTWHY2436</b>	109	Tour 120° Corner Worksurface
<b>TSTWHY2442</b>	109	Tour 120° Corner Worksurface
<b>TSTWHY2448</b>	109	Tour 120° Corner Worksurface
<b>TSTWLD30</b>	110	Tour Worksurface
<b>TSTWLD36</b>	110	Tour Worksurface

Style Number	Page	Description
<b>TSTWLR1842</b>	107	Tour Worksurface
<b>TSTWLR1848</b>	107	Tour Worksurface
<b>TSTWLR1854</b>	107	Tour Worksurface
<b>TSTWLR2436</b>	107	Tour Worksurface
<b>TSTWLR2442</b>	107	Tour Worksurface
<b>TSTWLR2448</b>	107	Tour Worksurface
<b>TSTWLR2454</b>	107	Tour Worksurface
<b>TSTWLR2460</b>	107	Tour Worksurface
<b>TSTWLR2466</b>	107	Tour Worksurface
<b>TSTWLR2472</b>	107	Tour Worksurface
<b>TSTWLR3060</b>	107	Tour Worksurface
<b>TSTWLR3066</b>	107	Tour Worksurface
<b>TSTWLR3072</b>	107	Tour Worksurface
<b>TSTWLT2348</b>	108	Tour Worksurface
<b>TSTWLT2354</b>	108	Tour Worksurface
<b>TSTWLT2360</b>	108	Tour Worksurface
<b>TSTWLT2366</b>	108	Tour Worksurface
<b>TSTWLT2372</b>	108	Tour Worksurface
<b>TSTWLT3248</b>	108	Tour Worksurface
<b>TSTWLT3254</b>	108	Tour Worksurface
<b>TSTWLT3260</b>	108	Tour Worksurface
<b>TSTWLT3266</b>	108	Tour Worksurface
<b>TSTWLT3272</b>	108	Tour Worksurface
<b>TSTWLY2436</b>	109	Tour 120° Corner Worksurface
<b>TSTWLY2442</b>	109	Tour 120° Corner Worksurface
<b>TSTWLY2448</b>	109	Tour 120° Corner Worksurface
<b>TSTWMP1242</b>	116	Modesty Panel
<b>TSTWMP1248</b>	116	Modesty Panel
<b>TSTWMP1254</b>	116	Modesty Panel
<b>TSTWMP1260</b>	116	Modesty Panel
<b>TSTWMP1266</b>	116	Modesty Panel
<b>TSTWMP1272</b>	116	Modesty Panel
<b>WBHS</b>	278	Binder Holder
<b>WFCS</b>	272	Freestanding Slatwall Stanchions
<b>WHB</b>	279	Hanging Brackets
<b>WHOOK</b>	281	Utility Hook
<b>WLTS</b>	278	Portrait Letter Tray
<b>WPCS</b>	279	Pen/Pencil Cup
<b>WS24</b>	273	12"H Slatwall Tile
<b>WS30</b>	273	12"H Slatwall Tile
<b>WS36</b>	273	12"H Slatwall Tile
<b>WS42</b>	273	12"H Slatwall Tile
<b>WS45</b>	273	12"H Slatwall Tile
<b>WS48</b>	273	12"H Slatwall Tile
<b>WS60</b>	273	12"H Slatwall Tile
<b>WSPS</b>	280	Personal Shelf
<b>WSQS</b>	280	Double Square Dish
<b>WSR24</b>	276	24" SlatRail
<b>WSR30</b>	276	30" SlatRail
<b>WSR36</b>	276	36" SlatRail
<b>WSR42</b>	276	42" SlatRail
<b>WSR48</b>	276	48" SlatRail
<b>WSR60</b>	276	60" SlatRail
<b>WSRFS</b>	275	Freestanding SlatRail Stanchions
<b>WSRU1</b>	277	SlatRail Pnl-Mount Brkts

<b>Style Number</b>	<b>Page</b>	<b>Description</b>
<b>WSRW</b>	277	SlatRail Wall-Mount Brkts
<b>WSW42AN</b>	274	Slatwall Brkt, 12"H Pnl-Mount
<b>WSWANS</b>	274	Slatwall Brkt, 12"H Pnl-Mount
<b>WSWM</b>	274	Slatwall Brkt, 12"H Wall-Mount
<b>WSWUSA</b>	274	Slatwall Brkt, 12"H Pnl-Mount
<b>WTCS</b>	281	Telephone Caddy

# Trademark List

- ® The following are registered trademarks for products of Steelcase Inc. or one of its related corporate entities: 4 o'clock, 900 Series, à la carte, Airtouch, Ally, Amia, Answer, Archipelago, Avenir, Ballet, Bix, Brayton International, Cachet, Canopy, Canto, Chancellor, Coalesse, Confidante, Context, Convene, CopyCam, Criterion, Crushed Can, Currency, dash, Designtex, Details, Detour, Drive, Elective Elements, Ellipse, Ember Chrome, Emerge, E-Table 2, FYI, Garland, Gentry, Ginkgo Biloba, Groupwork, Ideo, Jacket, Jenny, Jersey, Kart, Kick, LaCosta, Leap, Let's B, LiveBack, Max-Stacker, media:scape, Metro, Migrations, Mitra, Montage, Nurture, Oriana, Parade, Pathways, PCT, Permiso, Player, PolyVision, Portal, Power Pincher, Progeny, Protégé, R2, Rally, Relevant, Reply, Rizzi Arc, Sensor, Series 9000, Siento, Sieste, Sine, Softcare, Springboard, Steelcase, Steelcase Design Partnership, Stella, Stow Davis, Swathmore, TeamWork, Technique, Texpress, Think, Thunder, Topo, Train, Turnstone, Underline, Unison, Vecta, Viridian, Walden, Werndl, and X-Stack.
- ® The following registered trademarks are under license from AWI Licensing Company, Dover, DE: SoundScapes, DuraBrite, BioBlock, and Armstrong.
- ® The following registered trademarks are under license from Byrne Electrical, Rockford, MI: Interport, Mini-Port, Axil Z, and Ellora.
- ® The following is a registered trademark of DuPont, Wilmington, DE: Corian.
- ® The following is a registered trademark of Genlyte Thomas Company, Louisville, KY: Lightolier.
- ® The following is a registered trademark of Hilti Corporation, FL-9494 Schaan, Principality of Liechtenstein: Hilti.
- ® The following is a registered trademark of Leviton Manufacturing Company, Little Neck, NY: Decora.
- ® The following is a registered trademark of Mechanical Plastics Corp, Elmsford, NY: Toggler.
- ® The following is a registered trademark of Microsoft Corporation, Redmond, WA: Microsoft.
- ® The following is a registered trademark of Panduit Corporation, Lockport, IL: Panduit.
- ® The following is a registered trademark of Trav (Press), Cuneo, Italy: Assisa.
- ® The following is a registered trademark of Virtual Ink, Boston, MA: mimioActive.
- ® The following registered trademarks are under license from Wilkhahn Furniture Products: Avera, Senzo, Versal, and Wilkhahn FS.
- ® The following is a registered trademark of Wilsonart International, Temple, TX: Chemsurf.

- ® The following is a registered trademark of Wiremold, West Hartford, CT: Wiremold.
- ® The following is a registered trademark of EMU Group S.P.A., Perugia, Italy: Emu.
- ™ The following are trademarks for products of Steelcase Inc. or one of its related corporate entities: <5\_MY, Access, Active/Passive Shelf, Ainsley, Akira, Alcove, Alerion, alight, Amaris, American Elect, American Tradition, ap40, Arbor, Arriva, Asana, Ascot, Aspekt, Astor, Await, Bira, Bivi, Bottomline, Brody, Brook, Buoy, Burton, c:scape, Calla, Calm, Camber, Campfire, Capa, Cappuccino, Cesar, Chester, Chord, Circa, Clarendon, Classic Rectangular, cobi, Collaboration, Community, Company, Convey, Cortex, Coupe, Crea, Crew, Cura, Cypress, Davenport, Dearborn, Deck, Déjà, Denizen, Denska, Derby, Divisio, Donovan, Dune, Duo, e<sup>3</sup>, e<sup>3</sup> ceramicsteel, e<sup>3</sup> environmental ceramicsteel, Echo, Edge, Elsa, Empath, Empress, Enea, ño, EnSync, Enviro, Escapade, Exchange, Exponents, Field, Flat Top, FlexFrame, Flip Top, Flute, Folio, FrameOne, FreeFlow, Frontier, Galilei, Gesture, Ginger, Ginkgo, Go Wall, Grip, Groove, Hatchback, Hawthorne, Hitch, Host Collection, Hosu, Huddleboard, i2i, Impact, Indy, InfoLink, IOS, I-Solve, Jack, Jarrah, Jetty, Juice, Kami, Kast, Kathryn, Lagunitas, Lark, L'Attitude, LearnLab, Leela, Lincoln, Linden, LiveSeat, Loria, Lyric, Malibu, Malibu Too, Mansfield, Marathon, Martini, Mason, Masque, Millbrae, Mineral, Mingle, Mystic, Mystic Metal, Mystic Wood, Montreal, Move, Nadia, Neighbor, nesso, Nickel, Nikko, Nod, Node, Norfolk, Ontrak, Oom, Opus, Orchid, Outlook Collection, Ovation, Paloma, Paperflo, Parliament, Pasio, Passerelle, Patriarch, Payback, Peek, Pile File, Pisa, Pool, PUCK, QiVi, Quba, Rave, Reed, Regard, Relay, Reunion, Ripple, Riser, Rocco, Rocky, RoomWizard, Runner, Satellite, Sawyer, ScapeSeries, Senti, Sentinel, Senza, Sequoia, Session, ShareLink, Shield, Shortcut, Sidewalk, Skylar, Slumber, Smoke, Snug, Soft Leaf, Sonata, Sorrel, SOTO, Stationkits, Stiletto, Surprise!, Switch, Symphony, Sync, TagWizard, Tava, TeamStudio, TeamTheater, Tenaro, Terrazzo, Theorem, Thread, Topaz, Touchdown, Tour, Tower Too, Trees, Trillium, Trolley, tX2, U-Free, Uno, V.I.A., Verb, Verge, Victor2, Visalia, Waldorf, Woodruff, Workspring, and X-tenz.
- ™ The following is a trademark of Microsoft Corporation, Redmond, WA: Windows.
- ™ The following is a trademark of Rodman Industries, Inc., Oconomowoc, WI: ResinCore1.
- ™ The following is a trademark of Ultrafabrics, LLC, Elmsford, NY: Ultraleather.
- ™ The following trademarks are under license from Wilkhahn Furniture products: Cana, Linus, Logon, Picto, Range, Stitz, Thema, Timetable, and Tubis.
- ™ The following is a trademark of MBDC, Charlottesville, VA: Cradle to Cradle and C2C.

- ™ The following trademarks are under license from Walter Knoll: Andoo, Bob, Lazlo, Lox, Ribbon, and Together.
  - ™ The following trademarks are under license from PP Möbler: Bar and Flag Halyard.
  - ™ The following trademarks are under license from Viccarbe: Davos, Holy Day, Last Minute, RS, and Wrapp.
  - ™ The following trademarks are under license from Carl Hansen: Elbow, Paddle, Shell, Wing, and Wishbone.
  - ™ The following trademarks are under license from Cambridge Sound Management, LLC, Cambridge, MA: QtPro Soundmasking, Qt Quiet Technology, and Sonet Qt.
  - ™ The following is a trademark of Electri-Cable Assemblies, Shelton, CT: Interact.
- Trademarks used here in are the property of Steelcase, Inc. or of their respective owners.*