

Ellipse Desk System Specification Guide

Availability

Electronic price list updated with release 182.A (U.S.) and 147.A (Canada), dated April 20, 2015.

Spec News is available on village.steelcase.com. Search AdStock and download the current release's Spec News.

View or download Steelcase Specification Guides at <http://www.steelcase.com/en/resources/design/spec-guides/pages/specguides.aspx>.

Transitional products in this specification guide are **maintained for existing customers only** and are likely to be phased out over time. These products are indicated with a . Products that are scheduled to be culled are indicated with an , followed by the last order entry date.

This specification guide contains multiple Steelcase and Turnstone product lines

which are designed into one specification guide for your convenience. Note that each product may be subject to different pricing terms and conditions.

► For a list of all trademarks, refer to the last page of this specification guide.
© 2015 Steelcase Inc.



For Canadian Pricing

Canadian factor can be found at steelcase.com/CADpricing.

Calculate in the following order to avoid rounding errors:

- Multiply the base price and each option by the Canadian factor.
- Round each to the nearest dollar.
- Add base and options for total list price.

Working With This Specification Guide

Twelve Tips: How to Get the Most Out of This Book	2
Identifying Characteristics of Ellipse	4
Examples	6
Additional Resources	10

Understanding Ellipse

11

Specifying Ellipse

51

Surface Materials

129

Resources

141

Lock and Keying

142

Style Number Index

144

Twelve Tips: How to Get the Most Out of This Book

Tip 1

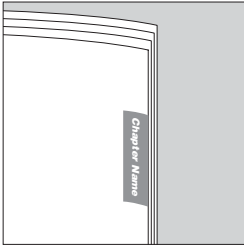

Watch the tabs on the right-hand edges of the pages. They'll always indicate which chapter you are in.

Tip 2

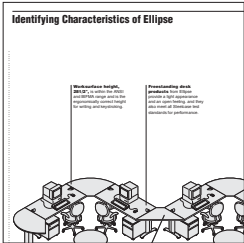

Review the identifying characteristics pages for an introduction to Ellipse and the product features that make it a unique furniture system.

▶ Page 4

Tip 3

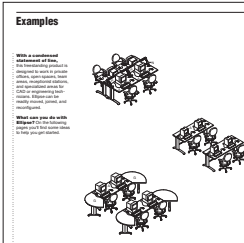

Review examples for ideas about how to configure Ellipse components to meet different workplace needs.

▶ Page 6

Tip 4

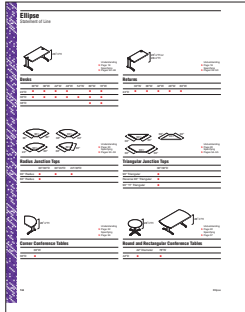

Use the statement of line pages for an overview of the available components, their sizes, and page references for additional information. Each *Understanding* chapter includes a statement of line after the table of contents.

Tip 5

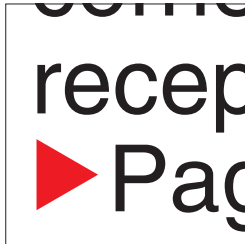

Find cross references by looking for page numbers flagged with an arrow.

Tip 6

Study the product detail pages in the *Understanding* section to learn everything an expert knows about specific products. Each product detail page in this section contains the following features, where applicable:

- Product Drawing
- Actual Dimensions
- Product Details
- Connections
- Wiring and Cabling
- Surface Materials
- Application Topics

Product Drawing shows you what the product looks like and points out important features.

Product Details gives specific information on the product and how it is used.

Connections describes how the product is assembled or how it attaches to another product.

Surface Materials lists what material is used for each part of the product.

Product Details

Connections

Wiring and Cabling

Surface Materials

Application Topics

Actual Dimensions table lists the dimensions of the product.

Dimensions	Desk	Return	Power Beams
Desk depth	30"	30"	30"
Desk width	24" or 30"	30"	30"
Desk height	29" or 30" or 31"	29" or 30" or 31"	29" or 30" or 31"
Desk return depth	24" or 30"	N/A	N/A
Desk return width	24" or 30"	N/A	N/A
Desk return height	29" or 30" or 31"	N/A	N/A
Desk return depth	24" or 30"	N/A	N/A
Desk return width	24" or 30"	N/A	N/A
Desk return height	29" or 30" or 31"	N/A	N/A
Desk return depth	24" or 30"	N/A	N/A
Desk return width	24" or 30"	N/A	N/A
Desk return height	29" or 30" or 31"	N/A	N/A
Desk return depth	24" or 30"	N/A	N/A
Desk return width	24" or 30"	N/A	N/A
Desk return height	29" or 30" or 31"	N/A	N/A

Wiring and Cabling details the cable-routing capabilities of the product.

Application Topics provides useful advice on how to apply the product.

Identifying Characteristics of Ellipse

Worksurface height, 28¹/₂", is within the ANSI and BIFMA range and is the ergonomically correct height for writing and key-stroking. Adjustable-height legs are available to allow the worksurface to be adjusted to any height from 24¹/₂" to 32".

Freestanding desk products from Ellipse provide a light appearance and an open feeling, and they also meet all Steelcase test standards for performance.

Sloped edge on user side of worksurfaces increases comfort.

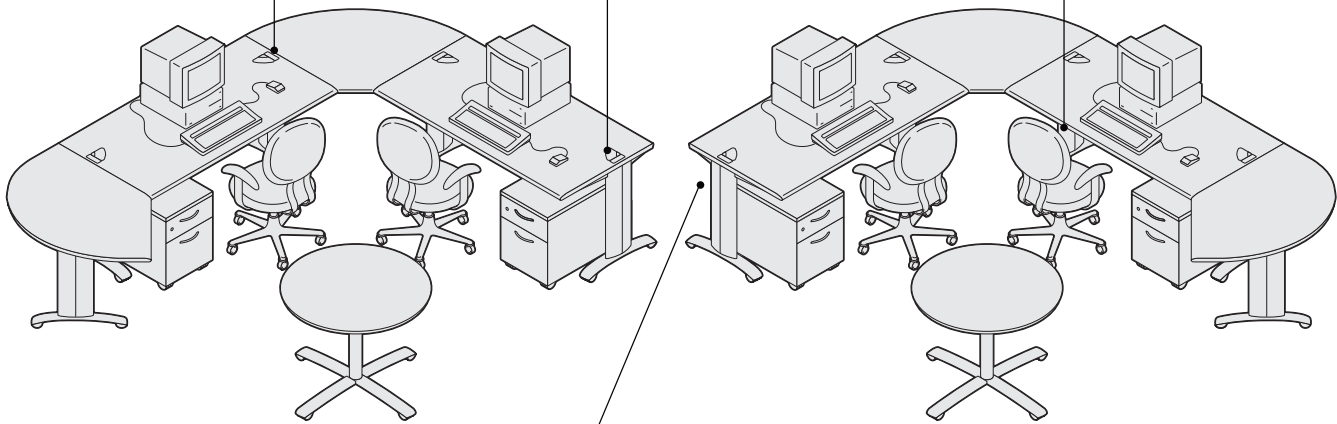

Lightly scaled products don't overpower small offices or work areas.

Small statement of line makes Ellipse an easy product line to work with and specify.

Diverse application of Ellipse allows it to be used in team spaces, training rooms, and private offices.

Accessories, such as Details Worktools, can be close at hand, but do not occupy the worksurface when they are installed on Details slatwall.

Panel systems, such as Answer, can be used with Ellipse.

Privacy can be enhanced when screens are added.

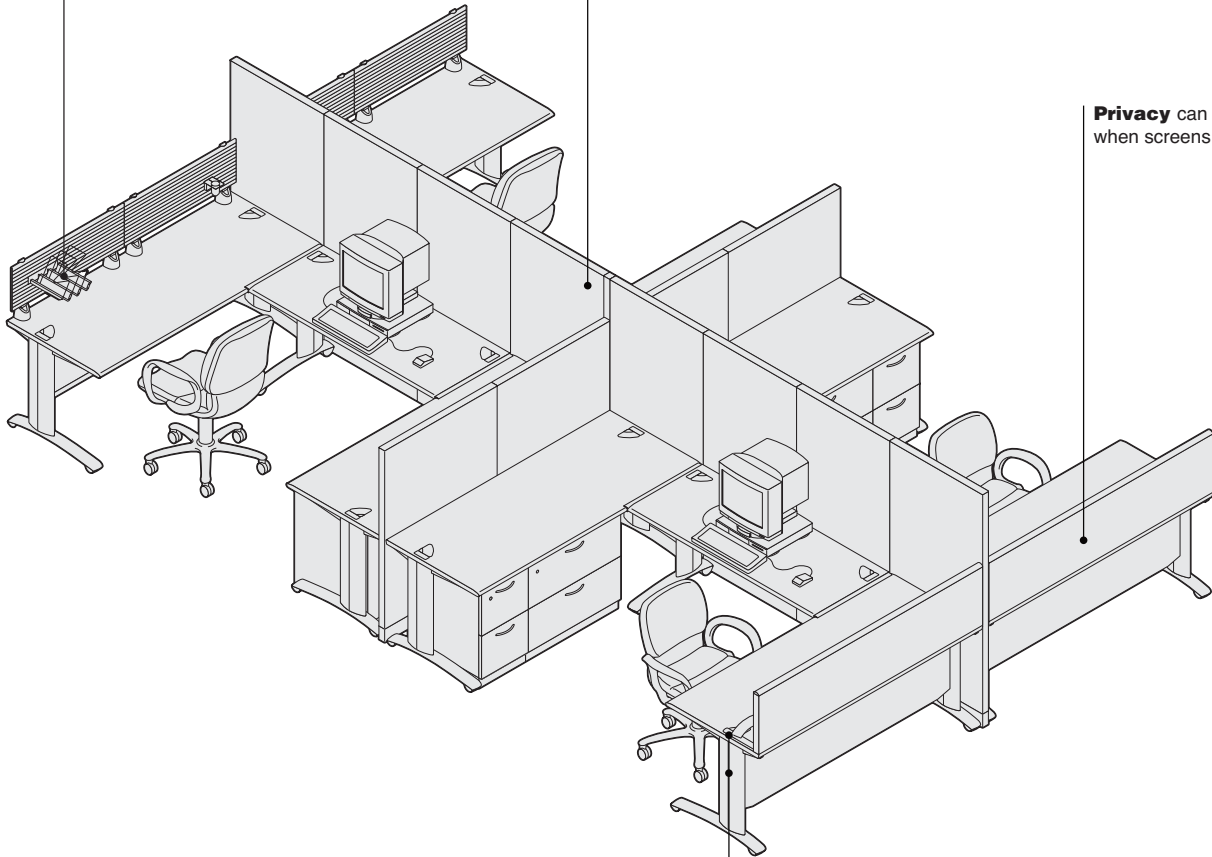

Cable routing is possible through grommets, power beams, and the space within the legs.

Reconfiguration and additions can be accomplished without going through a major installation.

Examples

With a condensed statement of line, this freestanding product is designed to work in private offices, open spaces, team areas, receptionist stations, and specialized areas for CAD or engineering technicians. Ellipse can be readily moved, joined, and reconfigured.

What can you do with Ellipse? On the following pages you'll find some ideas to help get you started.

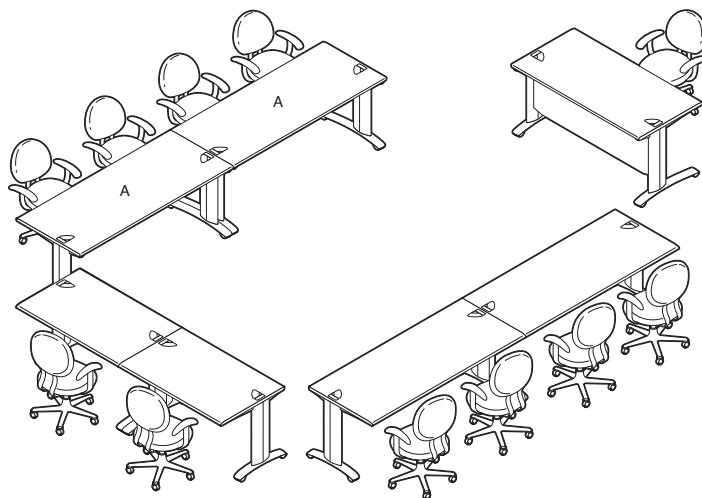
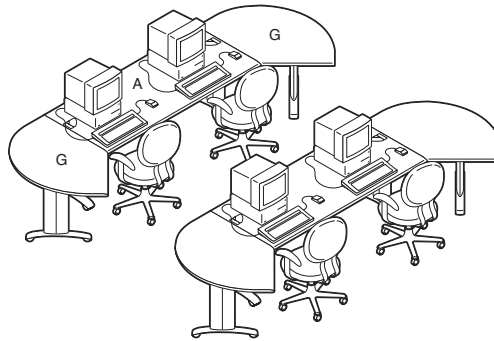
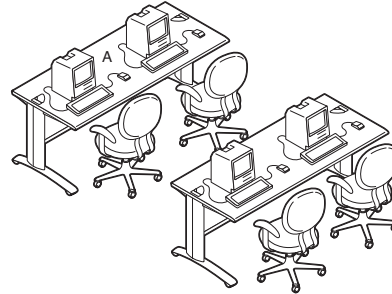
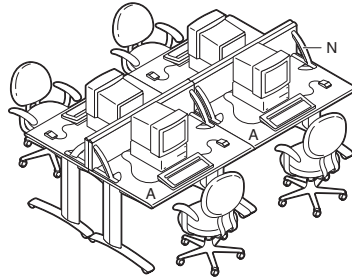

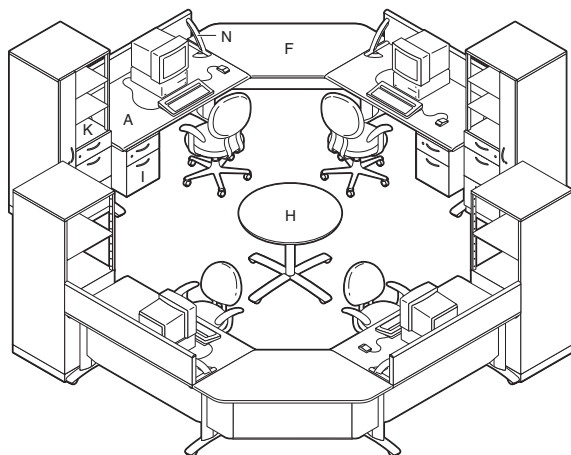
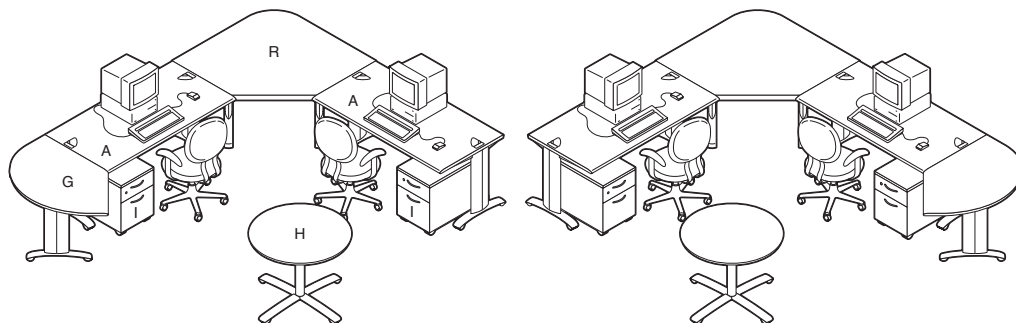
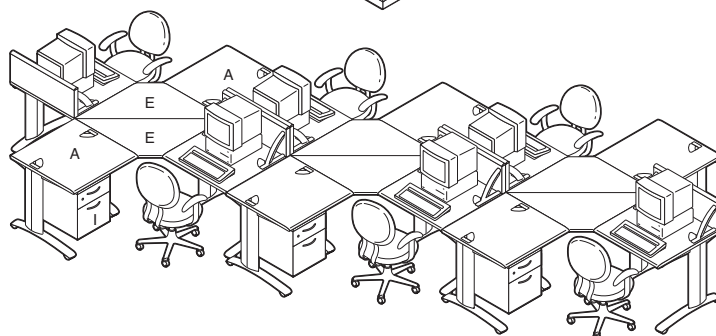
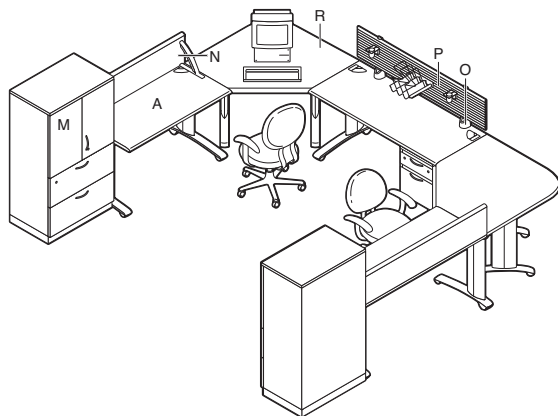

A = Desk

- ▶ Understanding page 18
- ▶ Specifying pages 52–59

E = Triangular Junction Top

- ▶ Understanding page 24
- ▶ Specifying page 63

F = "H" Junction Top

- ▶ Understanding page 24
- ▶ Specifying page 63

G = Corner Conference Table

- ▶ Understanding page 26
- ▶ Specifying page 64

H = Conference Table

- ▶ Understanding page 26
- ▶ Specifying page 66

I = Universal Pedestal

- ▶ Understanding, see *Storage Specification Guide*.
- ▶ Specifying pages 72–79

K = Universal Storage Towers

- ▶ Understanding, see *Storage Specification Guide*.
- ▶ Specifying, see *Storage Specification Guide*.

M = Universal Combination Cabinet

- ▶ Understanding, see *Storage Specification Guide*.
- ▶ Specifying page 84

N = Screens and Supports

- ▶ Understanding page 30
- ▶ Specifying pages 67–68

O = Details Freestanding Slatwall Stanchions

- ▶ See *Details Specification Guide*.

P = Details Slatwall

- ▶ See *Details Specification Guide*.

R = Corner Desk

- ▶ Understanding page 22
- ▶ Specifying page 61

Examples, continued

A = Desk

- ▶ Understanding page 18
- ▶ Specifying pages 52–59

B = Return

- ▶ Understanding page 18
- ▶ Specifying page 60

C = 90° Radius Junction Top

- ▶ Understanding page 24
- ▶ Specifying page 62

D = 60° Radius Junction Top (not shown)

- ▶ Understanding page 24
- ▶ Specifying page 62

E = Triangular Junction Top

- ▶ Understanding page 24
- ▶ Specifying page 63

F = "H" Junction Top

- ▶ Understanding page 24
- ▶ Specifying page 63

G = Corner Conference Table

- ▶ Understanding page 26
- ▶ Specifying page 64

I = Universal Pedestal

- ▶ Understanding, see *Storage Specification Guide*.
- ▶ Specifying pages 72–79

J = Universal Lateral File

- ▶ Understanding, see *Storage Specification Guide*.
- ▶ Specifying page 80

L = Common Top

- ▶ Understanding, see *Storage Specification Guide*.
- ▶ Specifying page 98

M = Universal Combination Cabinet

- ▶ Understanding, see *Storage Specification Guide*.
- ▶ Specifying page 84

N = Support

- ▶ Understanding page 30
- ▶ Specifying page 67

P = Screen

- ▶ Understanding page 30
- ▶ Specifying page 68

Q = Transaction Top

- ▶ Understanding page 30
- ▶ Specifying page 69

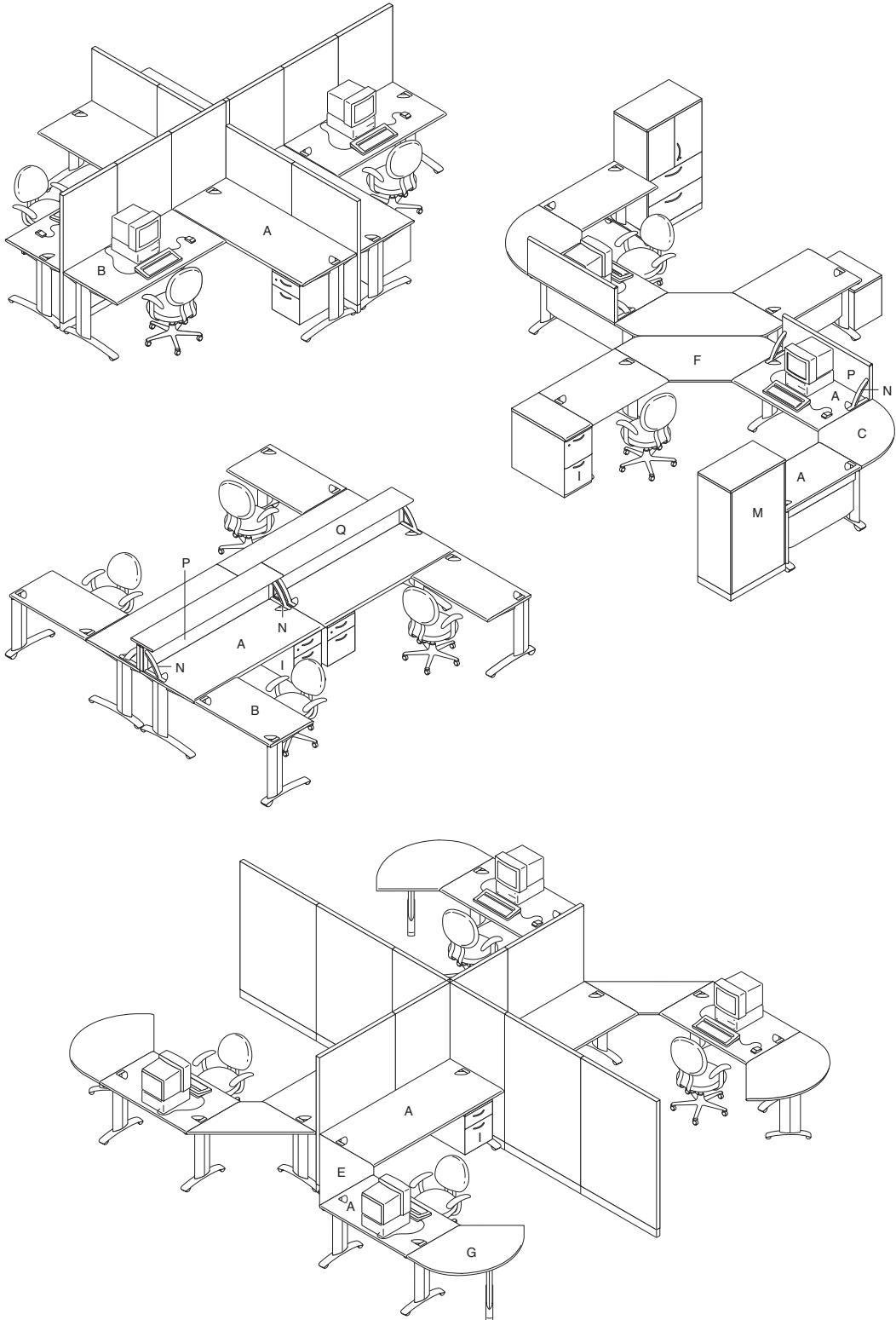

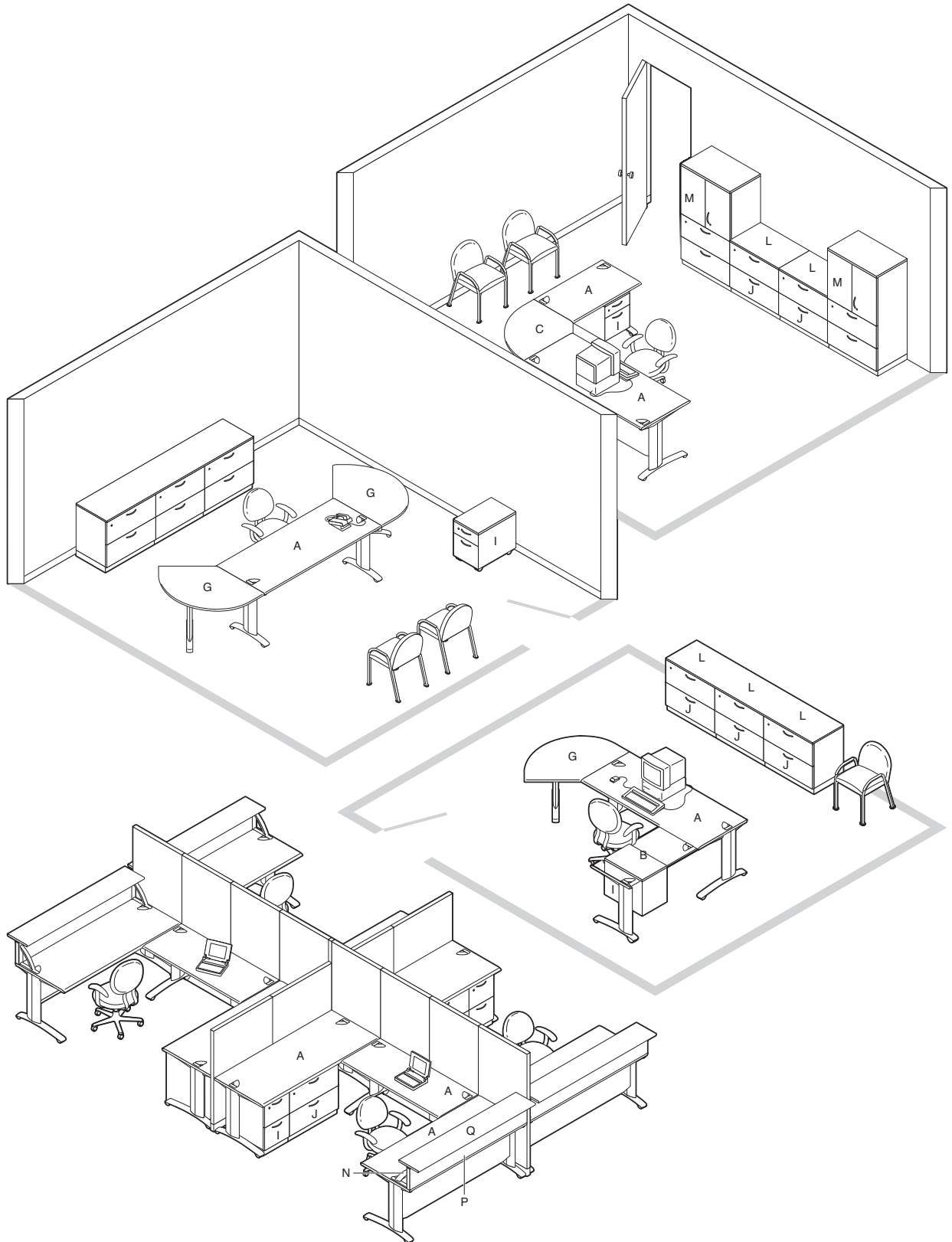

Additional Resources

Ellipse is supported with an array of informational materials, tools, and software to help you plan, specify, and order an installation efficiently.

Product brochures and planning tools can be ordered through your Steelcase area office by calling 1.800.784.0358 or through the AdStock web site at village.steelcase.com.

Product Brochures

Ellipse Product Brochure
05-0002128

Universal Storage Product Overview
03-0000387

Planning Tools

Quick Ship Guide

This handbook describes all Steelcase, Turnstone, Details, and Coalesse products that are available for Rapid2 (ships in 2 days), Rapid5 (ships in 5-7 days), or Coalesse Rapid10 (ships in 10 days).

Printed Materials

Surface Materials Reference Manual

This publication provides:

- An explanation of the surface materials program
- "Available on" matrices
- Vertical surface fabric and seating upholstery selection listing
- Technical data for surface materials
- Surface material care and cleaning instructions

Computer Tools



Digital Publications

If your device has a bar code reader App, scan this QR code for a direct link to the online digital publications. Utilizing this QR code allows you to search across multiple specification guides, share across social media, or print out pages. You can also access these digital publications at www.steelcase.com or village.steelcase.com.

Electronic Catalog

Accurate sales quotations and purchase orders for Steelcase products are created with specification software that uses Steelcase Electronic Catalog data. Use the data to specify and price style numbers and options for every Steelcase product. The data is updated bimonthly by Steelcase and provided to software programs including: the Hedberg Business System, SmartTools— Steelcase's design and specification software (for more information on SmartTools, please email SmartTools@steelcase.com), the ProjectMatrix ProjectSymbols libraries, as well as 20-20 CAP Studio.

Furniture Symbol Graphic Data

Steelcase creates 2D and 3D furniture symbols (with attributes) for planning and initially specifying Steelcase products. This data is incorporated into several add-on software packages that work in either a Microstation or an AutoCAD drafting environment.

For more information about these and other software tools to help you plan effective work environments, please email fsl@steelcase.com.

Ellipse Product Training

Basic training for Ellipse is available as part of the Building Product Muscle (BPM) curriculum on the Steelcase University Web site at village.steelcase.com.

The Ellipse BPM is a self-paced, printable module designed to build knowledge of Ellipse's positioning, statement of line, features and benefits, competitive products, application, and sales presentation for Steelcase and dealer salespeople. The Ellipse BPM is course SAL107.

Support

Steelcase Capabilities
Steelcase products are distributed, installed, and serviced through a network of more than 600 dealers worldwide. Steelcase is also represented with offices and corporate showrooms in 26 U.S. cities, 4 Canadian cities, and in France, Germany, Great Britain, and Japan. Every Steelcase product meets our exceptionally high standards of quality and durability and comes with the Steelcase assurance of excellence in service.

For assistance, please call your local dealer, the Steelcase Solutions Resource Team, or the Steelcase Solutions Fulfillment Team at 1.888.STEELCASE (1.888.783.3522) or send an e-mail to lineone@steelcase.com.

Call the Steelcase Solutions Resource Team prior to placing an order, when working on a bid, or when you need information about product applications and specifications.

Call the Steelcase Solutions Fulfillment Team if you have submitted an order to Steelcase and you need to speak to your Solutions Fulfillment Team Representative about the order. Also call if you have any post-shipment quality or warranty concerns or service parts questions.

Outside the U.S.A., Canada, Mexico, Puerto Rico, and the U.S. Virgin Islands, call 1.616.247.2500.

For information about Steelcase, the name of your nearest Steelcase dealer, or for product literature, call 1.800.333.9939, or visit our Web site: www.steelcase.com.

Related Products

Avenir panels and upper storage are visually compatible with Ellipse furniture. Panels can be used to increase privacy. Overhead storage bins and shelves can be used with panels when storage above a work area is needed. *Avenir Specification Guide*

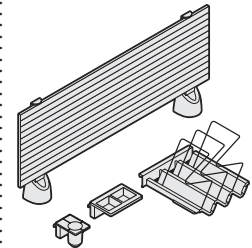

Details worktools

include a full line of ergonomically designed products that enhance and improve the work setting. Product platforms include computer support tools, organizational worktools, and personal lighting. ▶ For additional information refer to *Details Specification Guide* or contact Details at 888.783.3522 or email info@details-worktools.com.

Understanding Ellipse



Statement of Line	12
--------------------------	-----------

Ellipse Product Details

Desks and Returns	18
Corner Desks	22
Junction Tops	24
Conference Tables	26
Leg Choices	28
Supports, Screens, and Transaction Tops	30

Universal Storage

See *Storage Specification Guide*.

Application Topics

Safe Use of Storage Products	32
Ellipse Storage Capacities and Dimensions	33
Wiring and Cabling Overview	34
Cable Capacities	35

Internode Product Details

Internode Power and Communication Overview	36
Internode Statement of Line	37
Internode Wiring Schematics and Circuit Choices	38
Internode Power Infeeds	39
Internode Components	40
How to Calculate Power Needs	42
Locations with Special Requirements	43

Lighting

Shelf Lights	44
LED Shelf Lights	46

Statement of Line

Ellipse

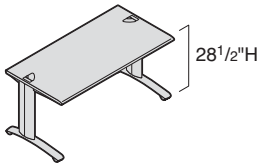

Understanding
 ▶ Page 18
 Specifying
 ▶ Pages 52–57

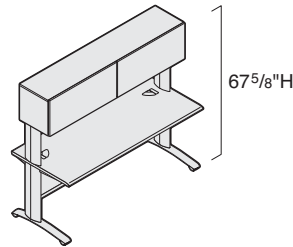

Understanding
 ▶ Page 19
 Specifying
 ▶ Page 58

Desks

	30"W	36"W	42"W	48"W	54"W	60"W	66"W	72"W
24"D	●	●	●	●		●	●	●
30"D	●	●	●	●	●	●	●	●
36"D						●		●

Desks with Overhead Cabinet

	42"W	48"W	54"W	60"W	72"W
30"D	●	●	●	●	●

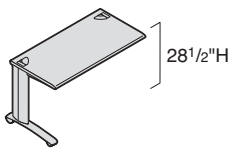

Understanding
 ▶ Page 18
 Specifying
 ▶ Page 60

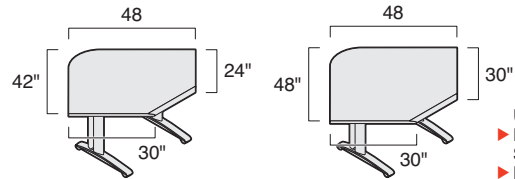
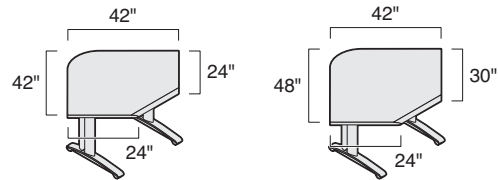

Understanding
 ▶ Page 22
 Specifying
 ▶ Page 61

Returns

	30"W	36"W	42"W	48"W	60"W
24"D	●	●	●	●	●

Corner Desks

	24"/24"D	24"/30"D	30"/24"D	30"/30"D
90°	●	●	●	●

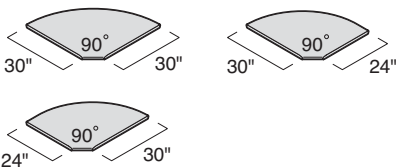

Understanding
 ▶ Page 24
 Specifying
 ▶ Page 62

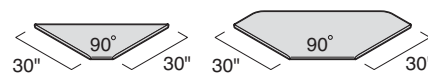

Understanding
 ▶ Page 24
 Specifying
 ▶ Page 63

Radius Junction Tops

	30"/30"D	30"/24"D	24"/30"D
90° Radius	●	●	●

Triangular Junction Tops

	30"/30"D
90° Triangular	●
90° "H" Triangular	●

For the full Universal Storage offering and the Storage Products Style Number Conversion List, see Storage Specification Guide.

Statement of Line

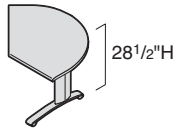

Understanding
▶ Page 26
Specifying
▶ Pages 64–65

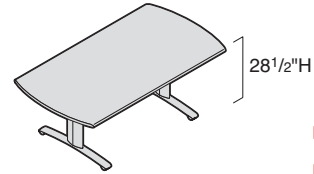
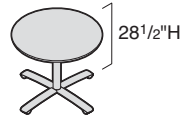

Understanding
▶ Page 26
Specifying
▶ Page 66

Understanding

Corner Conference Tables

	36"W
30"D	●

Round and Rectangular Conference Tables

	42" Diameter	78"W
42"D	●	●

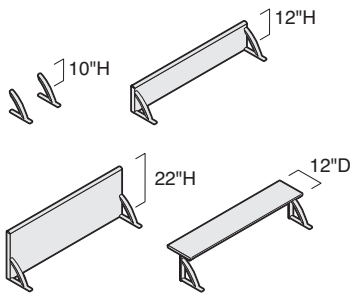

Understanding
▶ Page 30
Specifying
▶ Pages 67–69

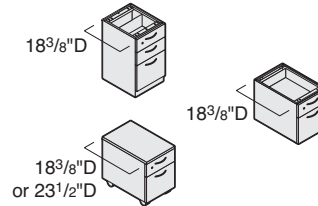

Understanding
▶ See Storage Specification Guide.
Specifying
▶ Pages 72–79

Supports, Screens, and Transaction Tops

	30"W	36"W	42"W	48"W	54"W	60"W	66"W	72"W
Screens	●	●	●	●	●	●	●	●
Transaction Tops	●	●	●	●	●	●	●	●

Pedestals

	Fixed	Mobile	Hanging
15"W x 18"H			●
15"W x 21"H		●	
15"W x 25 1/2"H	●		
15"W x 27"H	●	●	

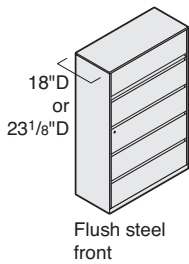

Flush steel front

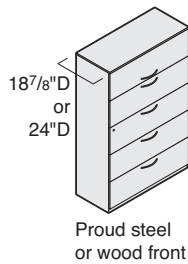

Proud steel or wood front

Understanding
▶ See Storage Specification Guide.
Specifying
▶ Page 80–83

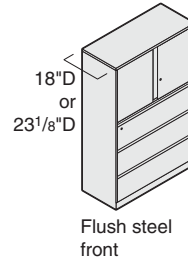

Flush steel front

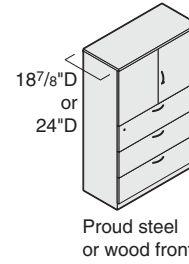

Proud steel or wood front

Understanding
▶ See Storage Specification Guide.
Specifying
▶ Page 84–88

Lateral Files

	30"W	36"W	42"W
28"H	●	●	●
40"H	●	●	●
52"H	●	●	●
65 1/2"H	●	●	●

Tip: 42"W lateral files are available 18"D and 18 7/8"D only.

Combination Cabinets

	30"W	36"W	42"W
52"H	●	●	●
65 1/2"H	●	●	●
83 1/2"H	●	●	●

Tip: 42"W combination cabinets are available 18"D and 18 7/8"D only.

Statement of Line

Universal Storage

For the full Universal Storage offering and the Storage Products Style Number Conversion List, see Storage Specification Guide.

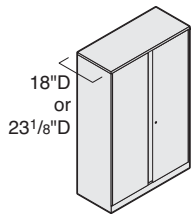

Flush steel front

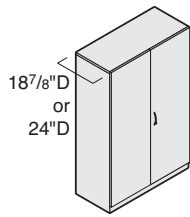

Proud steel or wood front

Understanding
 ▶ See *Storage Specification Guide*
 Specifying
 ▶ Page 90–92

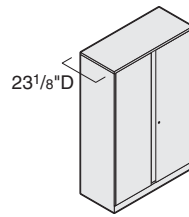

Flush steel front

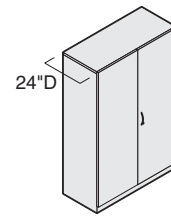

Proud steel or wood front

Understanding
 ▶ See *Storage Specification Guide*
 Specifying
 ▶ Page 94–96

Storage Cabinets

	30"W	36"W	42"W
28"H	●	●	●
40"H	●	●	●
52"H	●	●	●
65½"H	●	●	●
83½"H	●	●	●

Tip: 42"W storage cabinets are available 18"D and 18 7/8"D only.

Wardrobe Cabinets

	30"W	36"W	42"W
52"H	●	●	●
65½"H	●	●	●
83½"H	●	●	●

Tip: 42"W wardrobe cabinets are available 18"D and 18 7/8"D only.

Shelf lights mount into the recessed bottom of storage shelves and bins to illuminate the worksurface. Five types of shelf lights are available to control the quality of light for specific applications. Each type is compatible with Steelcase systems furniture and all major competitive furniture lines.

Shelf Lights

Storage-Mounted Lights

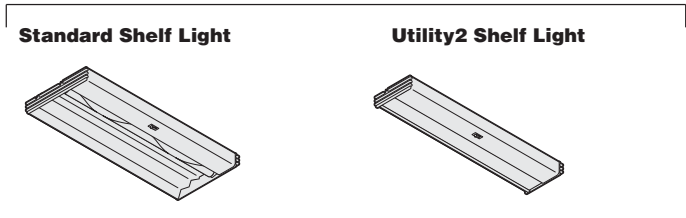

	Standard Shelf Light	Utility2 Shelf Light
Mounting Options	<ul style="list-style-type: none"> • Universal mounting package (standard) • Flush mount • Competitive mounting package 	<ul style="list-style-type: none"> • Universal and flush mounting package (standard)
	Understanding ▶ Page 44 Specifying ▶ Page 122	Understanding ▶ Page 44 Specifying ▶ Page 124
Depth	9¼"	6⅞"
Width	25", 37", or 49"	25", 37", or 49"
Color Temperature	3500K	3500K
Description	The right choice for the majority of people in today's workplace who switch frequently from task to task throughout the day.	Designed for use in display areas, service centers, under transaction tops, and other applications where glare control is not a primary consideration.
Optics	Faceted, white reflector Contrast sleeve that can be manually rotated to vary light	Silver reflector Prismatic lens— flat acrylic diffuser intensity
Ballasts	<ul style="list-style-type: none"> • Electronic ballast • High power factor 	<ul style="list-style-type: none"> • Electronic ballast • High power factor • Normal-power-factor ballast
Electronic Dimmer	<ul style="list-style-type: none"> • Not available 	<ul style="list-style-type: none"> • Not available
Lens Options	None	<ul style="list-style-type: none"> • Batwing lens option
Average Rated Lamp Life	<ul style="list-style-type: none"> • 20,000 hours 	<ul style="list-style-type: none"> • 20,000 hours
Warranty	<ul style="list-style-type: none"> • Ballast - 5 years • Fixture - 12 years 	<ul style="list-style-type: none"> • Ballast - 5 years • Fixture - 12 years

Shelf lights offer end users added control and adjustability to place the proper amount of task lighting to create a holistic worksetting. Ideally suited for recessed mount applications to bottom of bin or shelf.

LED Lights

Storage-Mounted Lights

LED Shelf Light

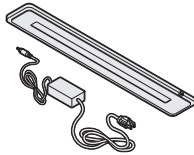

Mounting	<ul style="list-style-type: none"> Standard includes magnetic mount for steel bins and shelves. Optional fastener kit for wood and aluminum shelves are available. <p>Understanding ▶ Page 46 Specifying ▶ Page 126</p>
Depth	2½"
Width	18"
Color Temperature	3500K
Description	The most environmentally-friendly light in the portfolio. Consumes only 11 watts of power, contains no harmful metals (mercury), and has a useful life of over 50,000 hours. Ideally suited for recessed mount applications to bottom of bin or shelf.
Finish Options	<ul style="list-style-type: none"> Bottom surface clear anodized aluminum only. Plastic cover Arctic White (6009) or Black (6000).
Optics	<ul style="list-style-type: none"> Polycarbonate matte film
Ballasts	<ul style="list-style-type: none"> Energy saving low-voltage power supply
Electronic Dimmer	<ul style="list-style-type: none"> Standard on all lights
Average Rated Lamp Life	<ul style="list-style-type: none"> 50,000 hrs.
Warranty	<ul style="list-style-type: none"> Power supply - 5 years Fixture - 12 years

Personal task lights offer end users added control and adjustability to place the proper amount of personal lighting to create a holistic worksetting. Ideally suited for rail-mount, desk, or freestanding applications.

LED Lights

Rail-Mounted and Non Rail-Mounted

LED Personal Task Lights

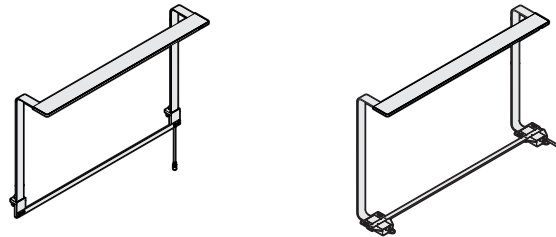

Mounting

- Rail-mounted attaches directly to rail systems in c:scape, FrameOne, Elective Elements, Impact, Turnstone Campfire Big Table, and Details SOTO Rail. The non rail-mounted version attaches to most freestanding desks and tables.
Tip: Non rail-mounted LED personal task lights will not work on worksurfaces with knife edge that is longer than 1¼", or with modesty panels or modesty screens closer than 6" from the back edge.

Understanding
▶ Page 48
Specifying
▶ Page 127

Depth

6"

Width

30"

Color Temperature

3500K

Description

Intended to be a primary light source, LED personal task light covers the user's active work zone with a smartly-designed array of light. The light is specifically designed to direct light where it is needed. Energy efficient at only 14 watts, LED personal task light is engineered to have a useful life of over 50,000 hours. It attaches directly to the rail systems of c:scape, FrameOne, Impact, Elective Elements, Turnstone Big Table, and Details SOTO Rail. A non-rail-mounted version attaches to freestanding desks and tables.

Finish Options

- Fixture and stanchions, paint: 4799 Platinum Metallic, 4231 Arctic White, 4710 Low Gloss Black. Plastic cover Arctic White (6009) only.

Optics

- Polycarbonate matte film

Ballasts

- Energy saving low-voltage power supply

Electronic Dimmer

- Standard on all lights

Average Rated Lamp Life

- 50,000 hrs.

Warranty

- Power supply - 5 years
- Fixture - 12 years

Desks and Returns

Desks are the primary building block of Ellipse workspaces.
 ▶ Specifying, pages 52–59

Returns are one of the ways to extend the desk's work-surface. Returns cannot be attached to corner desks.
 ▶ Specifying, page 60

Worksurfaces have a wood core with a laminate surface. Surface material wraps front and back edges.

Ends of laminate work-surfaces are finished with a 1 mm plastic edge.

Grommets are standard on both the left- and right-hand side of desks and returns and allow cords and cables to pass through the worksurface.

Access covers on legs are removable to allow cords and cables to be routed inside the legs.

Leg trim strips finish the vertical seam on the legs.

Glide covers conceal the leveling glides that adjust to allow installation on uneven floors.

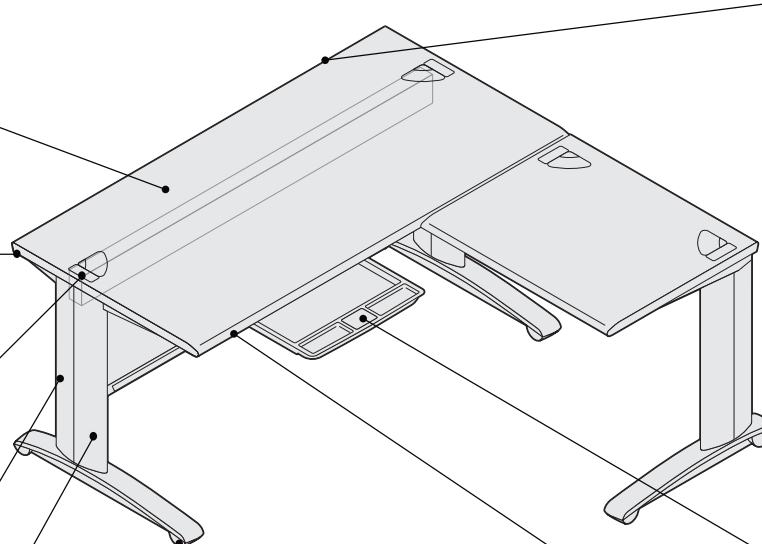

Radius edge is located on the back of the worksurface.

Center drawer is available field installed on desks and returns.
 ▶ Page 70

Sloped edge on the front of the worksurface angles down gradually toward the user.

Actual Dimensions

	Desk	Return	Power beam
Depth	24", 30", or 36"	24"	1¾"
Width	30", 36", 42", 48", 54", 60", 66", or 72"	30", 36", 42", 48", or 60"	24½", 30½", 36½", 42½", 48½", 54½", 60½", or 66½"
Height (with fixed leg)	28½"	28½"	N.A.
Height (with adjustable leg in ½" increments)	24½" to 32½"	N.A.	N.A.
Worksurface thickness	1¾"	1¾"	N.A.
Modesty panel-to-floor clearance	7½"	N.A.	N.A.
Modesty panel recess	1⅝", 7⅝", or 13⅝"	N.A.	N.A.
Power beam-to-floor clearance	22½"	N.A.	N.A.
Kneespace width clearance	Overall desk width minus 5½"	Overall return width minus 2¾"	N.A.
Leveling glide range	⅝"	⅝"	N.A.

Product Details

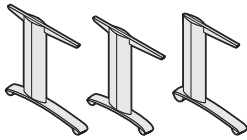

Legs are available in different versions to accommodate different worksurface depths and various combinations of components.

▶ Page 28

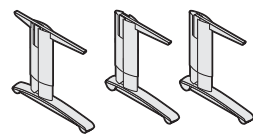

Adjustable legs are available on desks with a modesty panel. They allow work-surfaces to be supported at any height from 24½" to 32" in ½" increments.

▶ Page 28

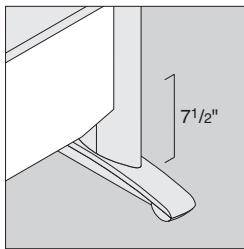

Modesty panel, available factory or field installed on desks, ends 7½" above the floor. Modesty panel, if selected, attaches to the power beam on desks and secures to the inside of the legs. Returns are not available with modesty panels.

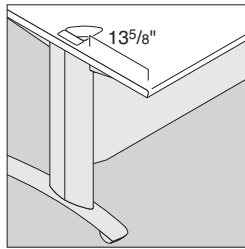

Overhanging top on 36"D desks provides kneespace for visitors and enables the desk to be used for conferencing. Overhang on the visitor's side is 13⅝".

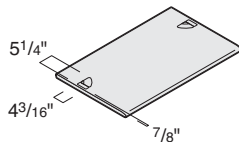

Grommets are 4⅜"D and 5¼"W. They are located ⅞" in from the worksurface edge.

Connections

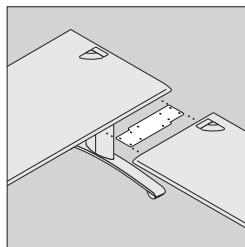

Flat bracket, shipped with the return, joins a return to a desk at the same height.

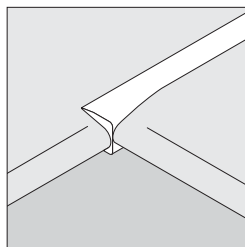

Filler is available to fill the gap between the contoured front edge of a desk and the end of a return or perpendicular desk at the same height.

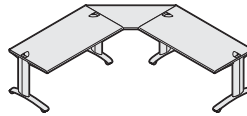

Junction tops and corner conference tables

join to desks only.
Tip: Desk must have an optional I-leg to allow the connection.

Tip: In-line ganging bracket can be used to connect two desks. Order part number 1105703SR.

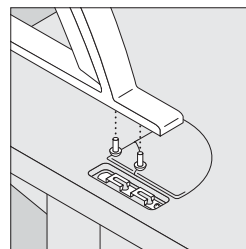

Support has pins that lock onto a bracket that is field installed in the recess that is adjacent to the grommet. A plastic cover conceals the recess if the supports are removed later.

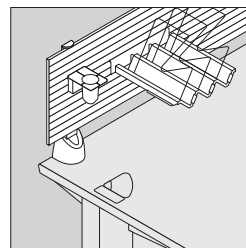

Details slatwall with free-standing slatwall stanchions added to desks accommodate a wide variety of work-tools and accessories.
▶ See the *Details Specification Guide*.

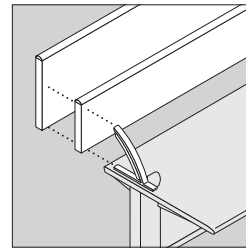

Screens connect to supports that are attached to desks and returns. They are available in two heights (12"H and 22"H) and have fabric-covered, tackable surfaces on both sides.

▶ Page 30

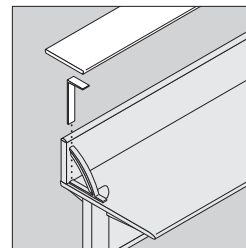

Transaction tops attach to the supports used with 12"H screens. Screens must be used.

▶ Page 30

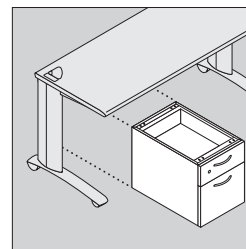

Hanging pedestals are field installed on desks and returns.

Tip: Maximum: two pedestals.

Tip: Returns can support only one pedestal mounted beneath the worksurface.

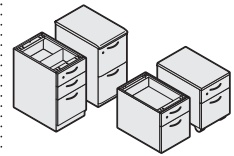

Universal pedestals can be installed beneath desks and returns.

- Fixed
- Mobile
- Freestanding (with Ellipse top)
- Hanging

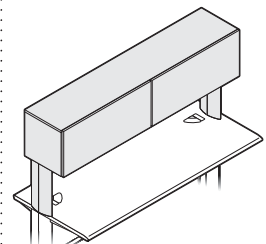

Desks with overhead cabinet accommodate binders and other resources within easy reach.

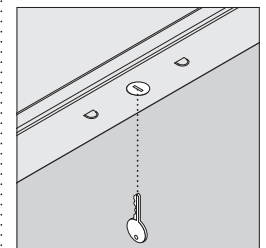

Lock in overhead cabinets is concealed from view beneath the shelf. Locks are available factory- or field-installed. Factory-installed locks are standard and available keyed random only. Two-door units are keyed alike. Optional field-installed locks are available with consecutive, specific, and random keying options. Master-keyed locks are also available. Field-installed lock cylinders must be specified separately.
▶ *Lock and Keying*, page 142

Overhead storage cabinet height accepts standard and A4 binders.

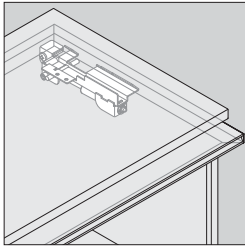

Door assist mechanism, optional, consists of a gas cylinder and spring that provides an assisted open and close of the door. When opening the door, the spring pulls the door to the fully recessed position. When closing the door, the assist mechanism will slowly close the door. The Ellipse overhead cabinet ships with one assist mechanism per door when specified.

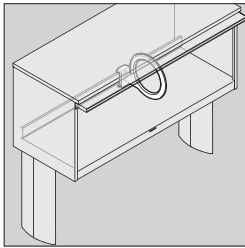

Dividers are available as an option for use on bins. Dividers ship in a package of four.

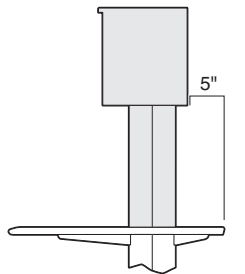

Distance from back of cabinet to back of work surface is 5".

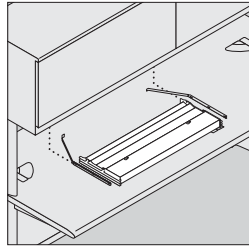

Shelf lights are available to recess into the bottom of overhead storage units.
 ▶ Page 44
 ▶ See *Ellipse Storage Capacities and Dimensions*, page 33.

Wiring & Cabling

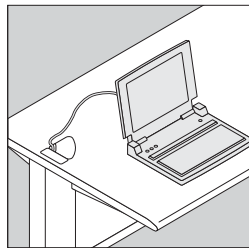

Removable plastic cover, on factory-installed grommet, permits plugs to pass through the work surface. A small triangular door opens to allow cords and cables to pass through.

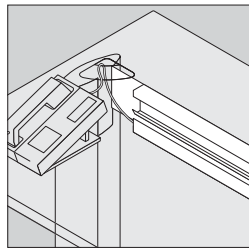

Power beam on desks routes cords and cables horizontally. Returns are not available with power beams.

Front lip on power beam is 1½"H. Power beam is always 20⅛" from front edge of desk.

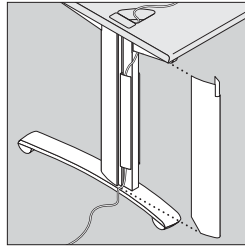

Space within legs of desks and returns allows cords and cables to be routed vertically from the floor to the power beam or worksurface. A removable cover provides access.

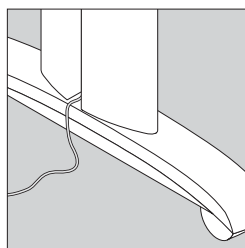

Cutout in the base of the leg serves as an entry and exit point for cords and cables.

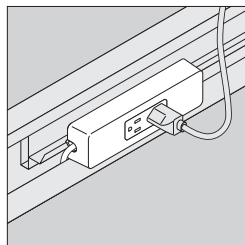

Power beam receptacle can be installed on the power beam beneath the work surface to provide convenient outlets.

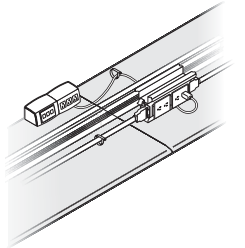

Internode components provide routing and access to receptacles and communication outlets on the underside and top of free-standing worksurfaces.
 ▶ Page 40

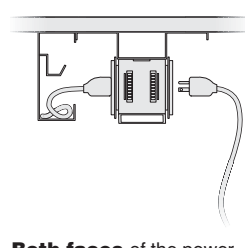

Both faces of the power block accommodate receptacles.

Surface Materials

Worksurface

- Laminate
- ▶ See *Surface Materials Reference Manual*.
- Open Line laminate (option)

A program including non-Steelcase laminates which are suitable for use on Steelcase products.
 ▶ See *Surface Materials Reference Manual*.

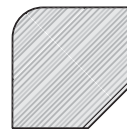

Tip: Grain direction of wood grain laminate is always parallel to the front edge of the worksurface.

Worksurface end

- Plastic default (standard on laminate worksurface)
- ▶ *Color Coordination Lists*, page 136

Legs, power beam, and modesty panel

- Paint

Leg trim strips and glide covers

- Plastic

Grommets

- Plastic default (standard on laminate worksurface)
- ▶ *Color Coordination Lists*, page 136

Return filler

- Plastic

Application Topics

Cable Capacities

- ▶ Page 35

Shipping

Palletizing streamlines unloading and staging of worksurfaces. Identical worksurfaces ordered on the same line item are packed on pallets containing 10–20 worksurfaces. Remaining worksurfaces are packed individually in cartons. If palletizing is not desired, order in quantities of nine or less per line item. For maximum unload efficiency, utilize pallet handling equipment at job site whenever possible.

Corner Desks

Corner desks are free-standing and can be used in conjunction with 24"D and 30"D desks.

▶ Specifying, page 61

Radius edge is located on the back of the worksurface.

Ends of laminate worksurfaces are finished with a 1 mm plastic edge.

Access covers on legs are removable to allow cords and cables to be routed inside the legs.

Leg trim strips finish the vertical seam on the legs.

Glide covers conceal the leveling glides that adjust to allow installation on uneven floors.

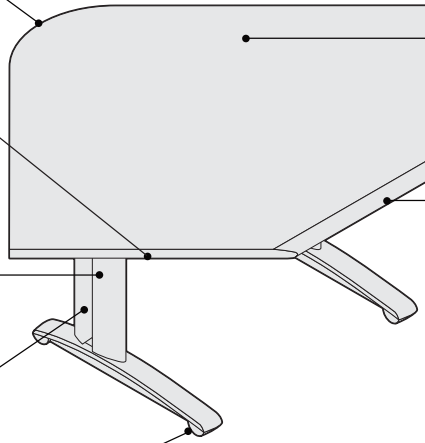

Worksurfaces have a wood core with a laminate surface. Surface material wraps front and back edges.

Sloped edge on the front of the worksurface angles down gradually toward the user.

Product Details

Freestanding corners are not intended to be connected to returns, but are designed to stand alone.

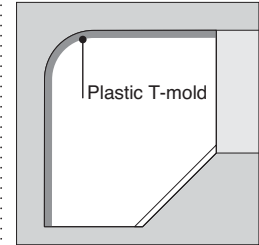

Back edge of freestanding corner is finished with plastic T-mold in a color that is determined by the worksurface color.
▶ See *Color Coordination Lists*, page 136.

Actual Dimensions

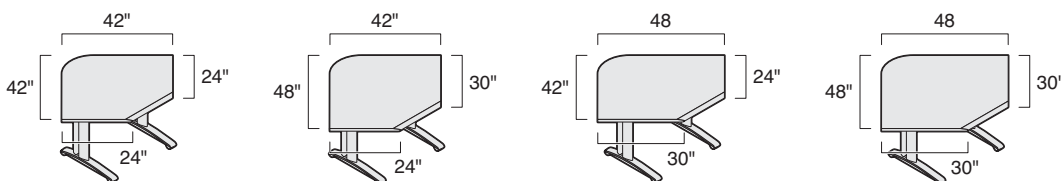

Wiring and Cabling

Power beam routes cords and cables horizontally.

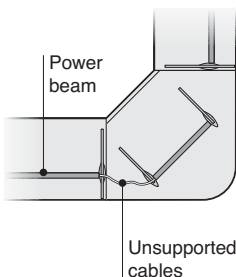

Cables routed through the freestanding corner will be unsupported for a short distance between the power beams of the adjacent desks.

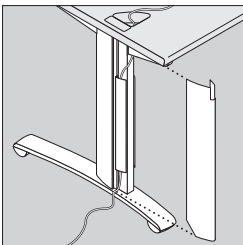

Space within legs of freestanding corners allows cords and cables to be routed vertically from the floor to the power beam or work surface. A removable cover provides access.

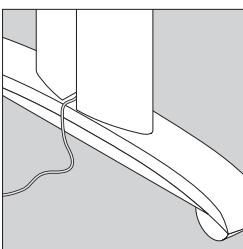

Cut out in the base of the leg serves as an entry and exit point for cords and cables.

Front lip on power beam is 1 1/2"H. Power beam is always 20 1/8" from front edge of desk.

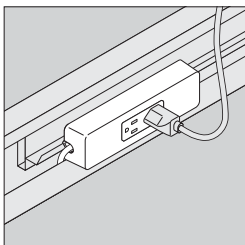

Power beam receptacle can be installed on the power beam beneath the work surface to provide convenient outlets.

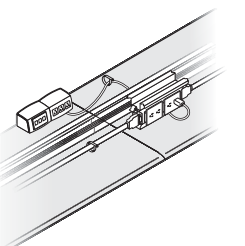

Internode components provide routing and access to receptacles and communication outlets on the underside and top of freestanding work surfaces. ▶ Page 40

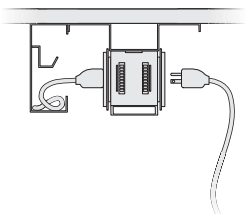

Both faces of the power block accommodate receptacles.

Surface Materials

Worksurface

- Laminate
 - ▶ See *Surface Materials Reference Manual*.
 - Open Line laminate (option)
- A program including non-Steelcase laminates which are suitable for use on Steelcase products.
- ▶ See *Surface Materials Reference Manual*.

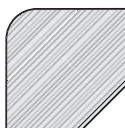

Tip: Grain direction of wood grain laminate is always parallel to the front edge of the worksurface.

Worksurface end

- Plastic default (standard on laminate worksurface)
- ▶ *Color Coordination Lists*, page 136

Back edge

- Plastic T-mold default (standard on laminate worksurface)
- ▶ *Color Coordination Lists*, page 136

Legs

- Paint

Leg trim strips and glide covers

- Plastic

Application Topics

Cable Capacities

- ▶ Page 35

Shipping

Palletizing streamlines unloading and staging of work surfaces. Identical work surfaces ordered on the same line item are packed on pallets containing 10–20 work surfaces. Remaining work surfaces are packed individually in cartons. If palletizing is not desired, order in quantities of nine or less per line item. For maximum unload efficiency, utilize pallet handling equipment at job site whenever possible.

Junction Tops

Junction tops offer various ways to extend the worksurface by linking to adjacent desks.

► Specifying, pages 62–63

Radius edge is located on the back of the worksurface and is finished with a plastic T-mold edge.

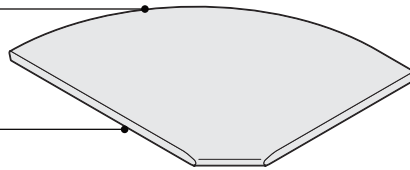

Ends of laminate work-surfaces are finished with a 1 mm plastic edge.



Worksurfaces have a wood core with a laminate surface.

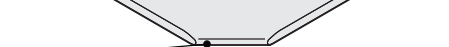

Sloped edge on the front of the worksurface angles down gradually toward the user.

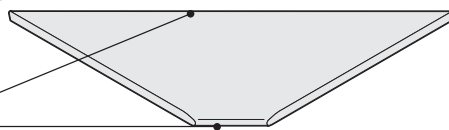

Back edges of triangular junction tops are finished with a laminate edge.

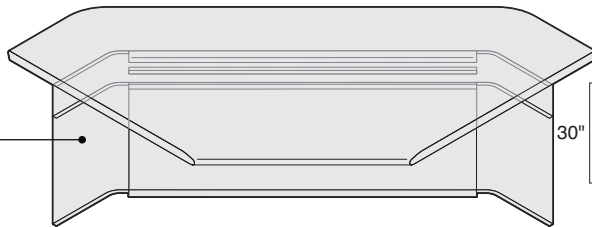

Modesty panel is available. It attaches to the power beam of junction tops.

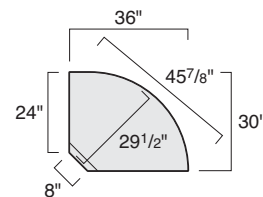
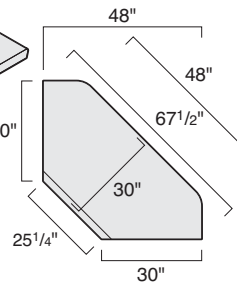
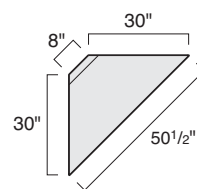
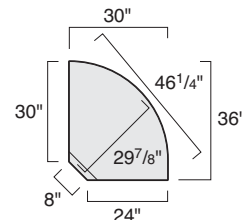
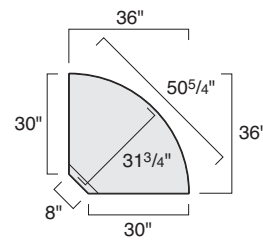
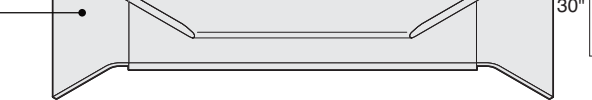

Product Details

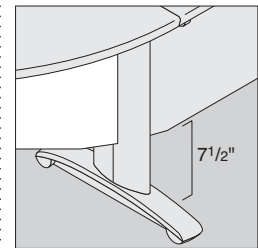

Modesty panel, if selected, ends 7 1/2" above the floor and aligns with modesty panels on adjacent desks.

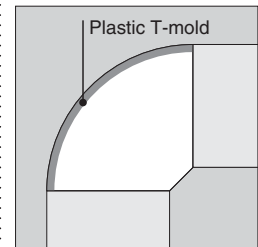

Back edge of all junctions is finished with plastic T-mold in a color that is determined by the worksurface color. Speckled worksurfaces will have solid-color back edges. Refer to the Color Coordination Lists, page 136.

Connections

Junction tops cannot be used to terminate a run of worksurfaces. Both sides of a junction top must be connected to a desk.

Attachment (ganging) brackets are shipped with junction tops and are attached to the worksurface.

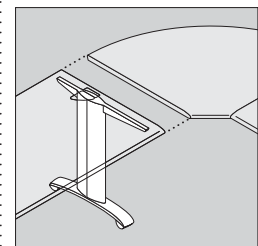

I-legs must always be specified on the ends of desks that are intended to support junction tops. Other desk legs don't accommodate worksurface connections.

Actual Dimensions

Depth	30"/30", 30"/24", or 24"/30"
Worksurface thickness	1 3/16"
Modesty panel-to-floor clearance	7 1/2"
Power beam-to-floor clearance	22 1/2"
Power beam to user edge	18 5/8"

Modesty panel, if selected, is field installed to the power beam.

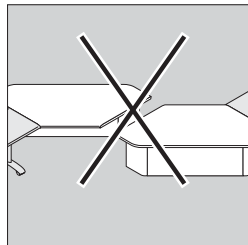

Junction tops do not connect to each other.
Tip: Junction tops are not designed to be converted to a freestanding desk.

Wiring & Cabling

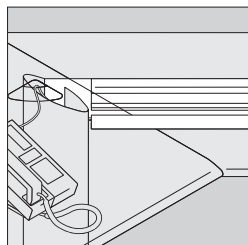

Power beam is available to route cords and cables horizontally.

Front lip on power beam is 1½"H. Power beam is always 20⅛" from front edge of desk.

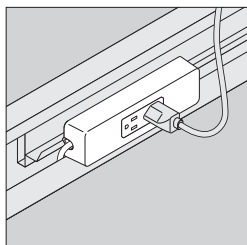

Power beam receptacle can be installed on the power beam beneath the worksurface to provide convenient outlets.

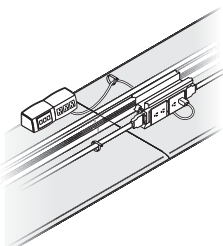

Internode components provide routing and access to receptacles and communication outlets on the underside and top of free-standing worksurfaces.
 ▶ Page 40

Surface Materials

Worksurface

- Laminate
 - ▶ See *Surface Materials Reference Manual*.
 - Open Line laminate (option)
- A program including non-Steelcase laminates which are suitable for use on Steelcase products.
 ▶ See *Surface Materials Reference Manual*.

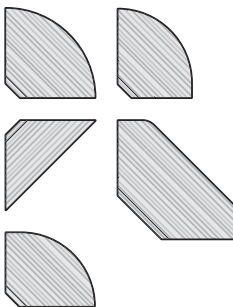

Tip: Grain direction of wood grain laminates is always parallel to the front edge of the worksurface.

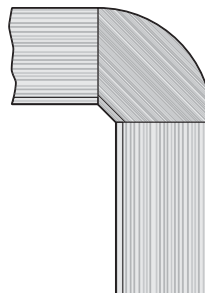

Tip: Make a sketch of the grain direction on adjacent worksurfaces to be sure they are suitable for your installation.

Worksurface end

- Plastic default (standard on laminate worksurface)
- ▶ *Color Coordination Lists*, page 136

Back edge

- Plastic T-mold default (standard on laminate worksurface)
- ▶ *Color Coordination Lists*, page 136

Power beam and modesty panel

- Paint

Application Topics

Cable Capacities

- ▶ Page 35

Shipping

Palletizing streamlines unloading and staging of worksurfaces. Identical worksurfaces ordered on the same line item are packed on pallets containing 10–20 worksurfaces. Remaining worksurfaces are packed individually in cartons. If palletizing is not desired, order in quantities of nine or less per line item. For maximum unload efficiency, utilize pallet handling equipment at job site whenever possible.

Junction Tops Require I-Legs

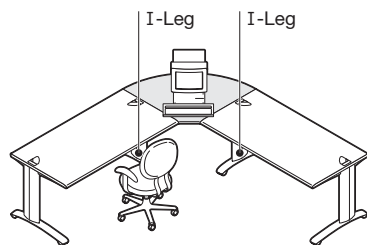

Radius junction tops provide curved transitions between adjacent desks. Both desks can have 30"D worksurfaces or one of the worksurfaces can be 24"D.

I-legs must be specified on the ends of the desks that are intended to connect to the junction tops.

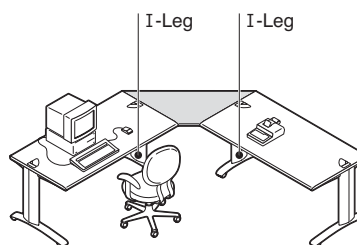

Triangular junction tops provide angled connections between adjacent desks. Both desks must have 30"D worksurfaces.

I-legs must be specified on the ends of the desks that are intended to connect to the junction tops.

Conference Tables

Corner conference

tables provide conferencing space and terminate the end of a run of worksurfaces.

► Specifying, pages 64–66

Radius edge is located on the back of the worksurface on a corner conference table. It is finished with a plastic T-mold edge.

Modesty panel is available on a corner conference table.

Freestanding conference tables provide meeting space and have details that match other Ellipse products.

Worksurfaces have a wood core with a laminate surface. The edge is finished with a plastic T-mold.

Sloped edge on the front of the worksurface angles down gradually toward the user.

Glide covers conceal the leveling glides that adjust to allow installation on uneven floors.

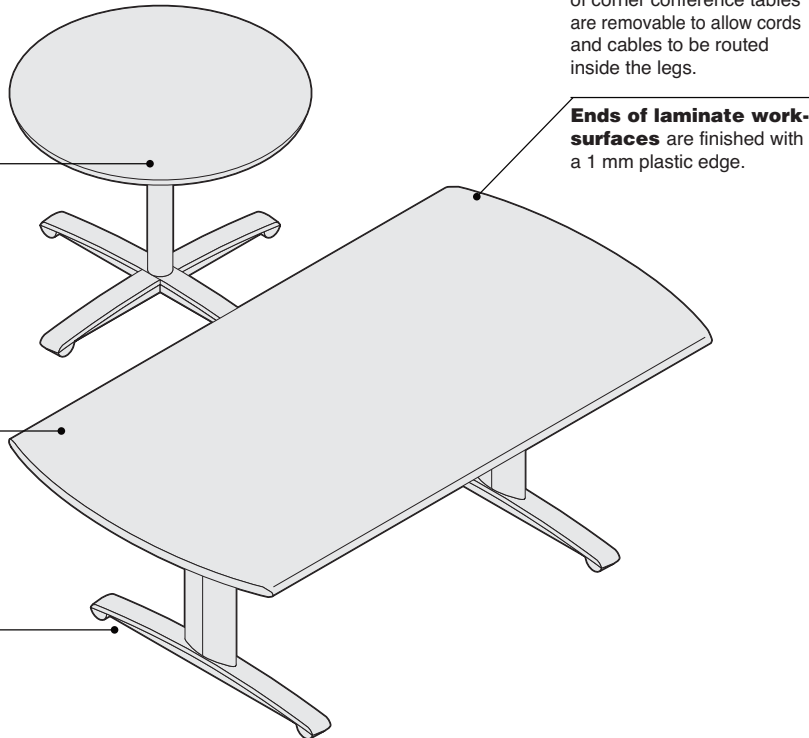
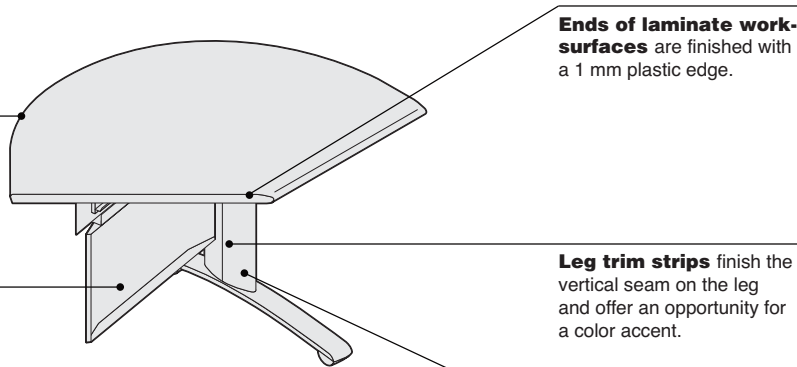

Product Details

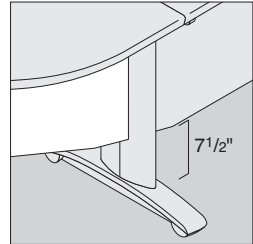

Modesty panel, if selected on a corner conference table, ends 7 1/2" above the floor and aligns with the modesty panel on the adjacent desk.

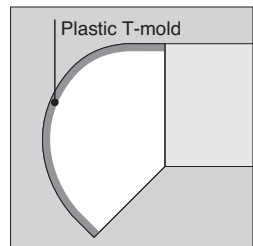

Back edge of corner conference tables is finished with plastic T-mold in a color that is determined by the worksurface color. Speckled worksurfaces will have solid-color back edges. Refer to the Color Coordination Lists.

► See *Color Coordination Lists*, page 136.

Actual Dimensions

	Corner conference table	Round conference table	Rectangular conference table
Diameter	N.A.	42"	N.A.
Depth	30"	N.A.	42"
Width	36"	N.A.	78"
Height	28 1/2"	28 1/2"	28 1/2"
Worksurface thickness	1 3/16"	1 3/16"	1 3/16"
Leveling glide range	5/8"	5/8"	5/8"

Connections

Corner conference tables connect to desks only and are used at the end of a run of worksurfaces. No worksurface can be connected to extend the run of worksurfaces beyond a corner conference table.

Only 30"D desks connect to corner conference tables. 24"D and 36"D desks do not connect to corner conference tables.

Attachment (ganging) brackets are shipped with corner conference tables.

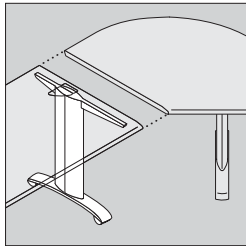

I-leg must always be specified on the end of the desk that is intended to support a corner conference table. Other desk legs don't accommodate worksurface connections.

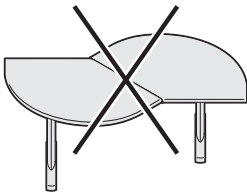

Corner conference tables do not connect to each other.

Round and rectangular conference tables are freestanding and do not connect to other Ellipse components. They also do not have power beams.

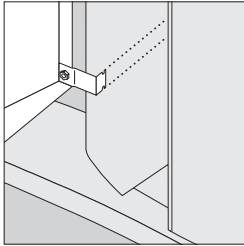

Modesty panel on a corner conference table is available shipped knocked down (K.D.). In the field the modesty panel attaches to the power beam and secures to the inside of the leg.

Wiring & Cabling

Power beam on corner conference tables routes cords and cables horizontally. Freestanding conference tables are not available with power beams.

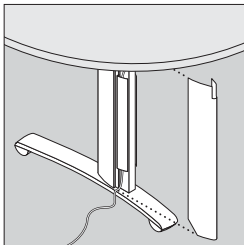

Space within leg on a corner conference table allows cords and cables to be routed vertically from the floor to the worksurface. A removable cover provides access.

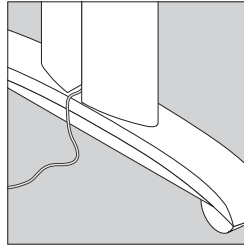

Cut out in the base of the leg on a corner conference table serves as an entry and exit point for cords and cables.

Power beam receptacle can be installed on the power beam beneath the worksurface of a corner conference table to provide convenient outlets.

Surface Materials

Worksurface

- Laminate
 - ▶ See *Surface Materials Reference Manual*.
 - Open Line laminate (option)
- A program including non-Steelcase laminates which are suitable for use on Steelcase products.
- ▶ See *Surface Materials Reference Manual*.

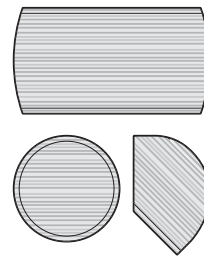

Tip: Grain direction of wood veneer and wood grain laminate is always parallel to the front edge of the worksurface.

Worksurface end

- Plastic default (standard on laminate worksurface)
- ▶ *Color Coordination Lists*, page 136

Back edge

- Plastic T-mold default (standard on laminate worksurface)
- ▶ *Color Coordination Lists*, page 136

Legs and modesty panel

- Paint

Column and base

- Paint

Leg trim strips and glide covers

- Plastic

Application Topics

Cable Capacities

▶ Page 35

Shipping

Palletizing streamlines unloading and staging of worksurfaces. Identical worksurfaces ordered on the same line item are packed on pallets containing 10–20 worksurfaces. Remaining worksurfaces are packed individually in cartons. If palletizing is not desired, order in quantities of nine or less per line item. For maximum unload efficiency, utilize pallet handling equipment at job site whenever possible.

Leg Choices

Tip: Wiring and cabling opening in all legs is 2 1/2" x 1"

C-Legs

Standard on 24"D desks

C-legs support 24"D worksurfaces only, so they do not have a back cantilever.

Adjustable-height C-legs are available. These legs adjust in 1/2" increments. Other increments can be achieved with adjustable glides. Modesty panels are required for stability on units with adjustable-height legs.

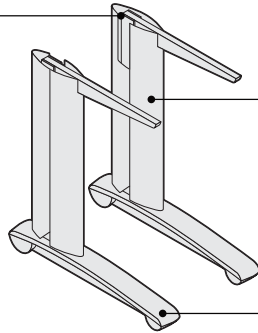

C-legs are used to finish the end of a desk or return that is 24"D. They cannot be used at the end of a desk that is attached to a junction top or corner conference table.

Foot of C-leg extends 14" for stability.

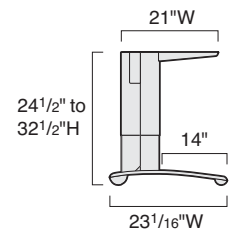
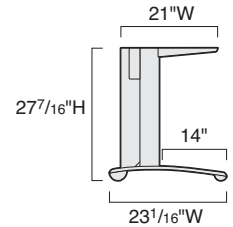

T-Legs

Standard on 30"D and 36"D desks

T-legs support 30"D and 36"D worksurfaces so they always have a back cantilever. They cannot be used to support a 24"D worksurface.

Adjustable-height T-legs are available. These legs adjust in 1/2" increments. Other increments can be achieved with adjustable glides. Modesty panels are required for stability on units with adjustable-height legs.

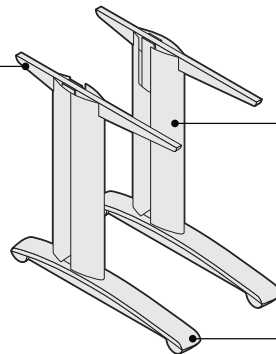

T-legs are used to finish the end of a desk. They cannot be used at the end of a desk that is attached to a junction top or a corner conference table.

Foot of T-leg extends 14" for stability.

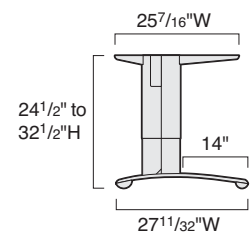
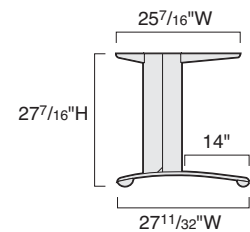

I-Legs

Option on desks linked to junction tops

I-legs come in two versions—one for 24"D worksurfaces and the other for 30"D and 36"D worksurfaces. Specify I-legs at the ends of desks that support adjacent junction tops or corner conference tables.

I-legs without back cantilever support 24"D worksurfaces.

Adjustable-height I-legs are available. These legs adjust in 1/2" increments. Other increments can be achieved with adjustable glides. Modesty panels are required for stability on units with adjustable-height legs.

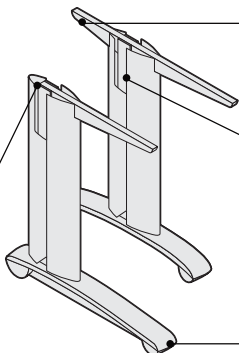

I-legs with back cantilever support 30"D and 36"D worksurfaces.

I-legs always have access slots in both sides of the leg cover. This allows the routing of cables from the desk's power beam to the junction top's power beam.

Foot of I-leg is 8" to allow clearance on 30"D and 36"D worksurfaces. Foot of I-leg is 14" to allow clearance on 24"D worksurfaces.

24" Deep Worksurface

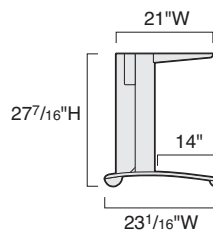

30" and 36" Deep Worksurfaces

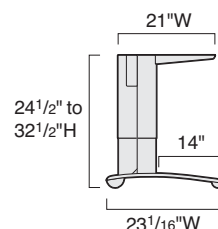
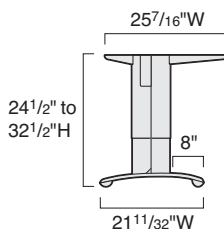
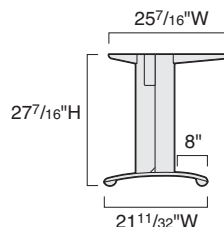

High-Capacity I-Legs

Option on desks linked to junction tops

High-capacity I-legs with oversized notch accommodates a high volume of cables beneath a 30"D and 36"D desks.

Adjustable-height high-capacity I-legs are not available.

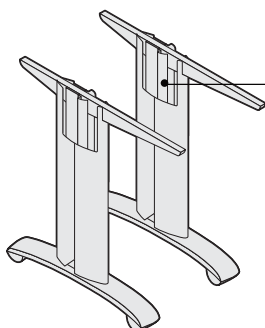

Enlarged notch in both sides of the upright allows access for cable routing in power beam. All other features match the standard I-legs.

30" and 36" Deep Worksurfaces

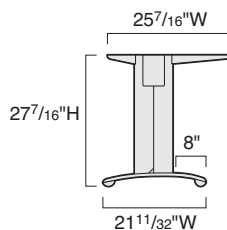

Supports, Screens, and Transaction Tops

Supports allow screens and transaction tops to be attached to desks and returns.

► Specifying, page 67

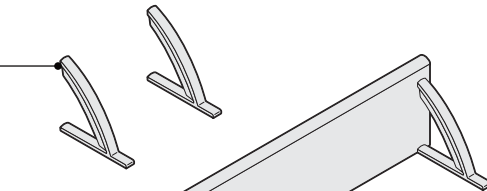

Screens have fabric-covered tackable surfaces on both sides.

► Specifying, page 68



Transaction tops, installed above 12"H screens, provide additional worksurface area.

► Specifying, page 69



Product Details

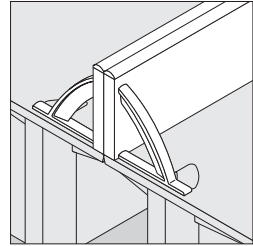

Screens can be installed back to back on adjacent workspaces, or two back-to-back workspaces can share a screen.

Tip: Screens cannot span two units.

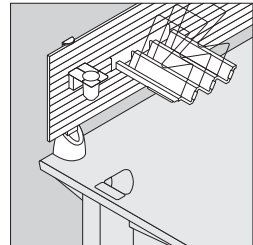

Details slatwall and Details freestanding stanchions are available for use on straight Ellipse desks with or without a modesty panel. Worktools can easily be repositioned by the user.

► See the *Details Specification Guide*.

Actual Dimensions

	Supports	Screens	Transaction tops
Depth	11"	1"	12"
Width	1"	30", 36", 42", 48", 54", 60", 66", or 72"	30", 36", 42", 48", 54", 60", 66", or 72"
Height	10"	12" or 22"	1"
Clearance to worksurface	N.A.	0"	12"

Connections

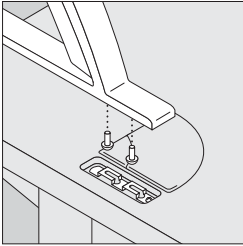

Support has pins that lock onto a bracket that is field installed in the recess that is adjacent to the grommet. A plastic cover conceals the recess if the supports are removed later.
Tip: Supports must be ordered to install and support screens.

Transaction tops can only be installed above 12"H screens.

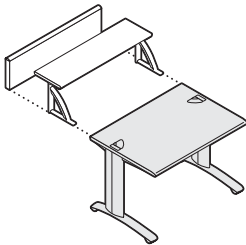

Length of screen and transaction top must match the length of corresponding desk or return.

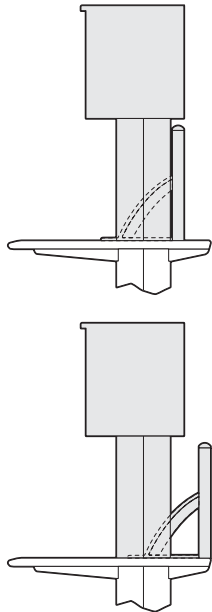

Screens can be installed beneath overhead cabinet unit flush with back of unit or flush with back of worksurface.

Tip: Screens, if specified, must be one size smaller in width than the worksurface. Example: Order 48"W for 54"W worksurface, 54"W for 60"W worksurface, etc.

Surface Materials

Supports

- Textured paint

Screen

- Vertical surface fabric (both surfaces must be the same fabric color)

Plastic trim strip on screen top

- 6681 Grotto plastic only

Transaction top

- Laminate
 - ▶ See *Surface Materials Reference Manual*.
 - Open Line laminate (option)
- A program including non-Steelcase laminates which are suitable for use on Steelcase products.
- ▶ See *Surface Materials Reference Manual*.

Attachment brackets for transaction top

- Textured paint (specify color to match supports ordered separately)

Application Topics

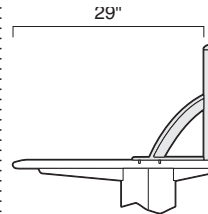
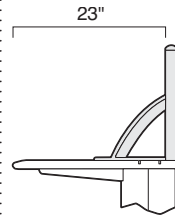

Screens can be flush to the back of 24"D and 30"D desks.

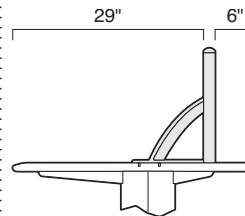

On 36"D desks, the screen is inset 6" from the back of the worksurface.

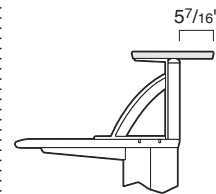

Transaction work-surface extends 57/16" beyond screen and will extend beyond the worksurface when used with either 24"D or 30"D worksurfaces.

Safe Use of Storage Products

Universal Storage and Lateral Files

Stability of unit is assured if they are properly installed and loaded. To avoid personal injury, each unit with roll-out components is standard with an interlock system that allows only one drawer or roll-out shelf to be opened at a time. In addition, there are steps that must be followed to prevent the tipping of a unit.

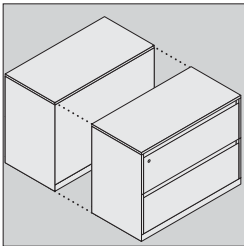

Gang unit with adjacent units, either side-by-side or back-to-back, or bolt unit to the floor or wall for stability. Ganging hardware is included with each unit.

Order a counterweight package option if recommended on specifying page and freestanding unit is not ganged to adjacent units or bolted to the floor or wall.

Counterweight packages prevent accidental tipping when an upper drawer or shelf is opened. They are ordered as an option, shipped separately and field-installed.

Load files starting with the bottom drawers or shelves. The upper drawers or shelves should be loaded last. Load units with the heaviest contents at the bottom.

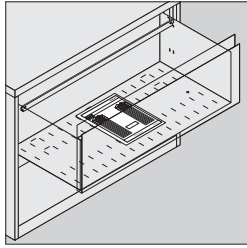

Follow the instructions that are shipped with the units to ensure that they are properly installed to provide safe performance.

Complete instructions for the safe installation and use of universal storage products are taped to the inside of the unit. Instructions include information about:

- Leveling files
- Ganging files together
- Counter-balancing files
- Removing and reinstalling drawers and shelves
- Moving files

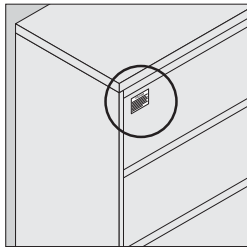

A temporary, peel-off caution label is affixed to the front of the top drawer or door exterior.

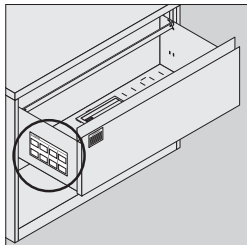

A permanent caution label is affixed to the left side of the top drawer or roll-out shelf and is visible when the drawer or shelf is opened.

Safety information for storage cabinets, bookcases, and over-files is included with the installation instructions that are shipped with the products.

Ellipse Storage Capacities and Dimensions

Ellipse Storage Capacities
and Dimensions

Plastic Center Drawer



Inside Dimensions		
D	W	H
12"	19"	1 ³ / ₈ "

Overhead Cabinets

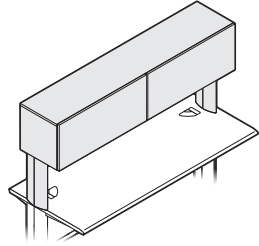

Size	Inside Dimensions		
	D	W	H
42"W cabinet	13 ³ / ₈ "	41 ¹³ / ₁₆ "	13 ¹ / ₄ "
48"W cabinet	13 ³ / ₈ "	47 ¹³ / ₁₆ "	13 ¹ / ₄ "
54"W cabinet	13 ³ / ₈ "	53 ¹³ / ₁₆ "	13 ¹ / ₄ "
60"W cabinet	13 ³ / ₈ "	59 ¹³ / ₁₆ "	13 ¹ / ₄ "
72"W cabinet	13 ³ / ₈ "	71 ¹³ / ₁₆ "	13 ¹ / ₄ "

Wiring and Cabling Overview

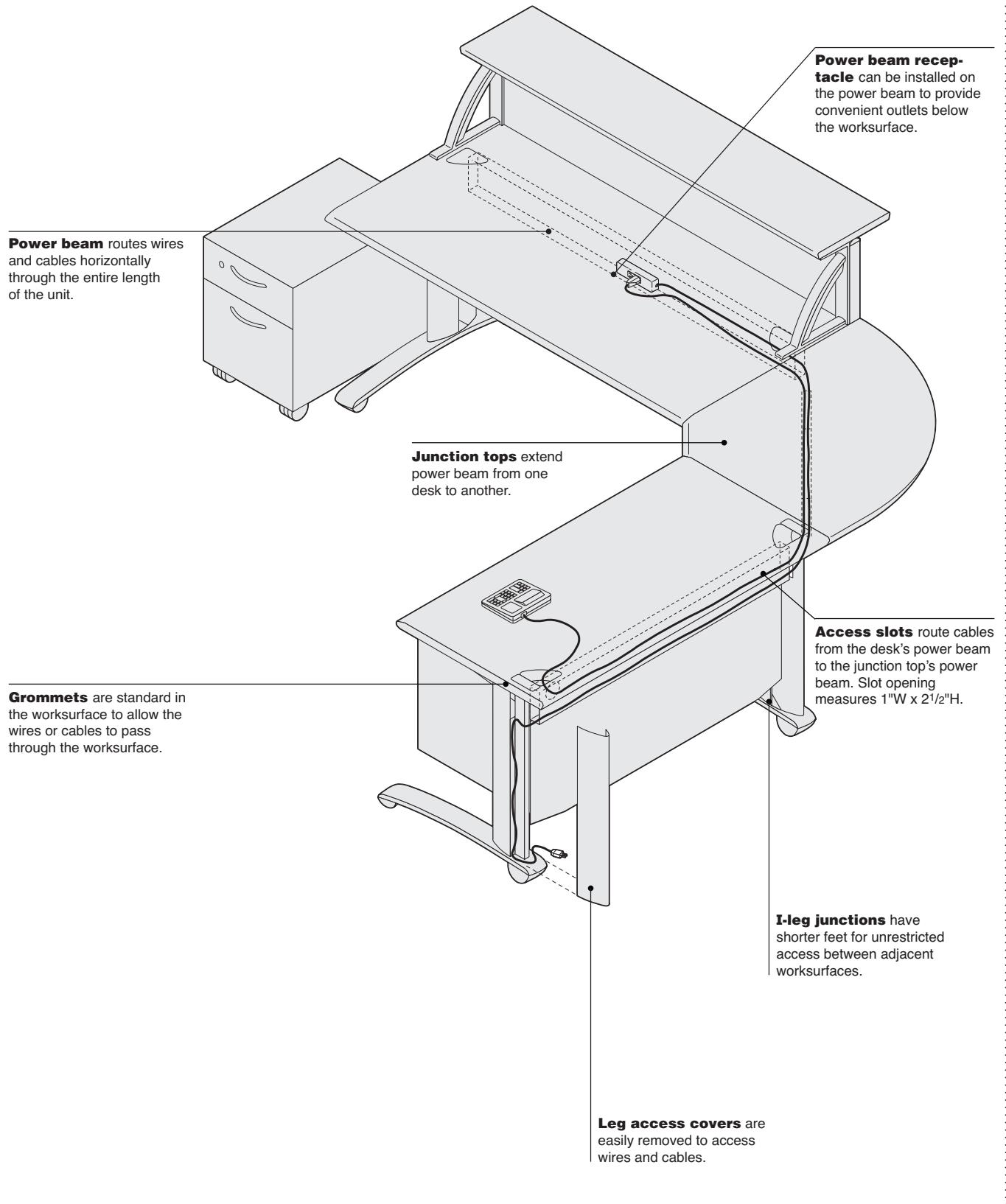

Test and verify capacities for your individual situation. Cable capacities in this table are based on non-plenum rated cables installed by a cable contractor under ideal conditions. Figures are approximations. Actual capacities may vary slightly depending on which manufacturer produced the cable and the specific field conditions.

Figures in the table are for a single cable carrier. In most applications, two or more cable carriers can be used. One cable carrier can be installed behind an upper beltway cover and two behind a lower beltway cover.

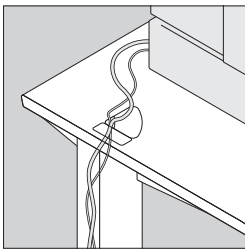

Grommet and leg accommodate cable capacities shown below.

Neatness of installation can affect capacities. In critical situations, you should try a test using the specific cable types your installation requires.

	Category 5 4-Pair	Category 5 4-Pair 350 mghz	Category 5 25-Pair	Category 3 4-Pair	Category 3 25-Pair	Multimode Fiber 4 Strand
Straight run: via power beam	45	45	8	75	20	60
T-leg	10	10	2	30	5	17

Internode Power and Communication Overview

Internode is a system of components that can be used to create power and communication networks beneath Ellipse worksurfaces and provide receptacles and communication outlets above or below the worksurfaces.

► Specifying, page 108

Power modules accommodate receptacles.

Receptacles snap into power module.

Communication module accepts NEMA or modular furniture faceplates.

Cord and cable manager organizes and stores cords and cables.

Convenience communication outlet housing supports customer-supplied faceplates.

Convenience tri-receptacles house three black receptacles.

Modular harnesses connect power modules to route power.

Mounting bracket attaches modules under worksurface.

Floor power infeed accesses power from the floor.

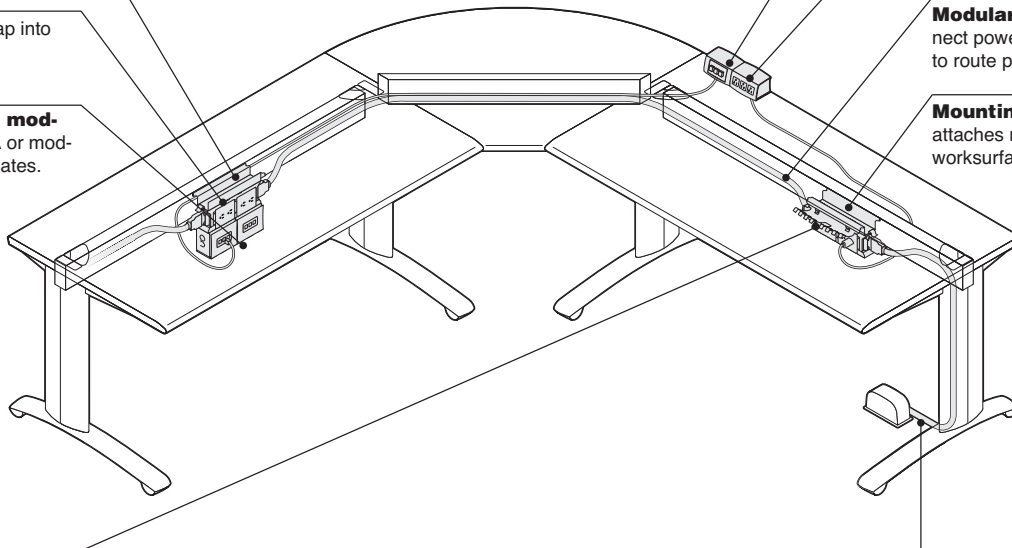

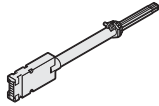

Floor power infeed
 Understanding
 ▶ Page 39
 Specifying
 ▶ Page 108

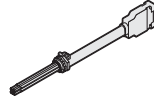

Multipurpose power infeeds
 Understanding
 ▶ Page 39
 Specifying
 ▶ Page 109

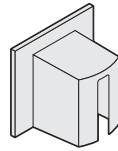

Modular infeed cover
 Understanding
 ▶ Page 39
 Specifying
 ▶ Page 109

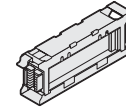

Power modules
 Understanding
 ▶ Page 39
 Specifying
 ▶ Page 110

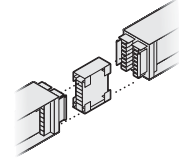

Block-to-block connector
 Understanding
 ▶ Page 40
 Specifying
 ▶ Page 110

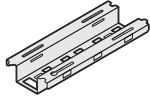

Mounting bracket
 Understanding
 ▶ Page 40
 Specifying
 ▶ Page 111

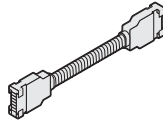

Modular harnesses
 Understanding
 ▶ Page 40
 Specifying
 ▶ Page 112

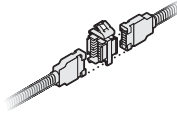

Harness-to-harness connector
 Understanding
 ▶ Page 41
 Specifying
 ▶ Page 112

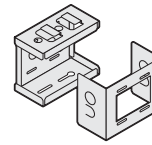

Communication module
 Understanding
 ▶ Page 40
 Specifying
 ▶ Page 114

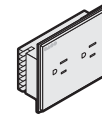

Receptacles
 Understanding
 ▶ Page 40
 Specifying
 ▶ Page 115

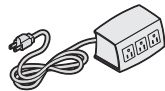

Convenience tri-receptacles
 Understanding
 ▶ Page 40
 Specifying
 ▶ Pages 117–118

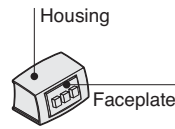

Convenience communication outlet housing
 Understanding
 ▶ Page 41
 Specifying
 ▶ Page 118

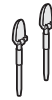

Above-worksurface clamp kit
 Understanding
 ▶ Page 41
 Specifying
 ▶ Page 119

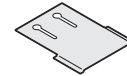

Below-worksurface mounting bracket
 Understanding
 ▶ Page 41
 Specifying
 ▶ Page 119

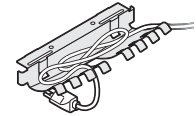

Cord and cable manager
 Understanding
 ▶ Page 41
 Specifying
 ▶ Page 120



Harness clips
 Understanding
 ▶ Page 41
 Specifying
 ▶ Page 120

Internode Wiring Schematics and Circuit Choices

Details for the Electrician

Internode offers three different wiring schematics to allow you to match your specific wiring strategy to any typical building wiring plan.

Tip: All the components in an electrical system must use the same wiring schematic. The components are color coded and keyed to make it impossible to connect mismatched parts.

Black = Four-circuit, 3+1

Brown = Four-circuit, 2+2

Rust = Three-circuit, separate neutrals

Shared neutral conductors = 10 gauge

Separate neutral conductors = 12 gauge

Hot conductors = 12 gauge

Grounding conductors = 12 gauge

Four-Circuit, 3+1

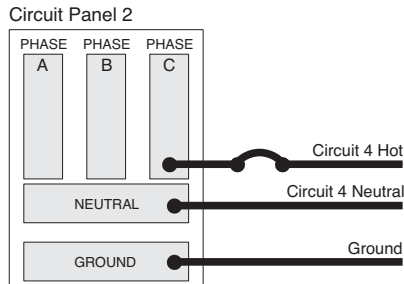
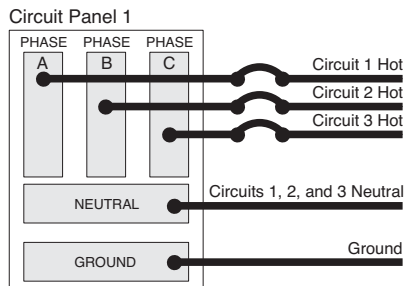

In the four-circuit 3+1 schematic, circuits 1, 2, and 3 are distributed from the first circuit panel and are supported with one shared neutral and one shared ground. Circuit 4 is distributed from a second circuit panel and is supported with a separate neutral and ground.

Single 3-Phase Circuit Panel

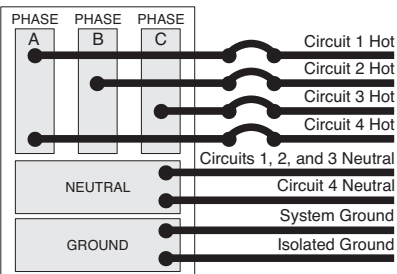

On a single 3-phase circuit panel, all four circuits are distributed as shown.

Four-Circuit, 2+2

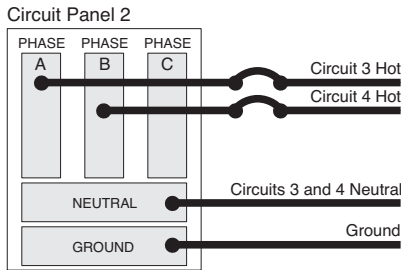
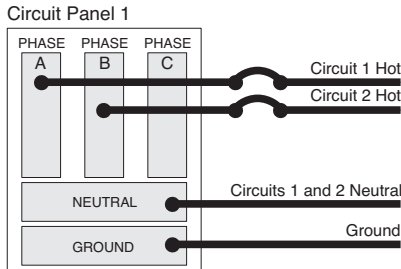

In the four-circuit 2+2 schematic, circuits 1 and 2 are distributed from two different phases from the first circuit panel and are supported with one shared neutral and one shared ground. Circuits 3 and 4 are distributed from a second circuit panel and supported by their own shared neutral and ground.

Single 3-Phase Circuit Panel

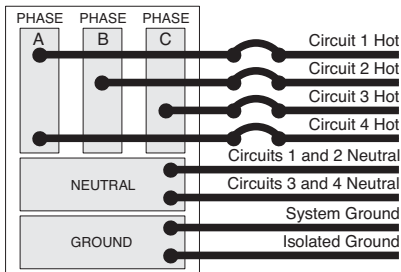

On a single 3-phase circuit panel, all four circuits are distributed as shown.

Split-Phase Circuit Panel

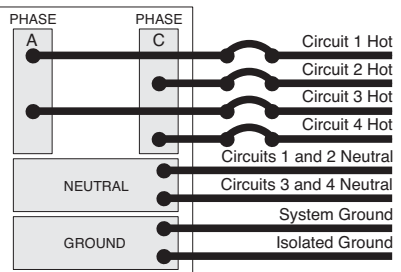

On a split-phase circuit panel, all four circuits are distributed as shown.

Three-Circuit, Separate Neutrals

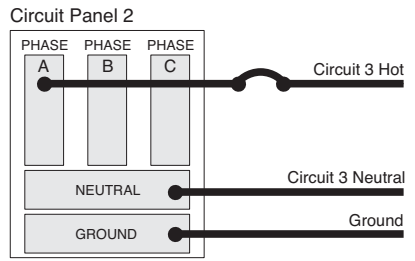
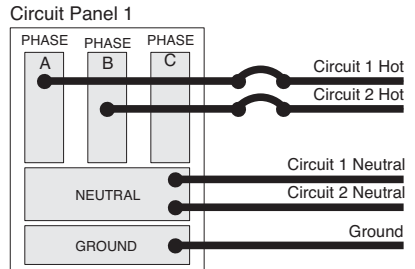

In the three-circuit, separate neutral schematic, circuits 1 and 2 are distributed from two different phases from the first circuit panel. Each circuit is supported with its own neutral and a common ground. Circuit 3 is distributed from the second circuit panel and is supported by its own neutral and ground.

Single 3-Phase Circuit Panel

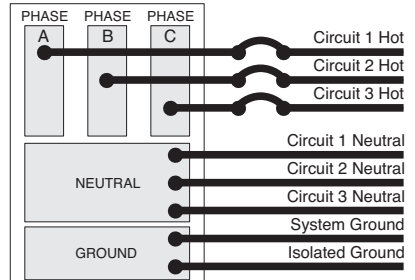

On a single 3-phase circuit panel, three circuits are distributed as shown.

Split-Phase Circuit Panel

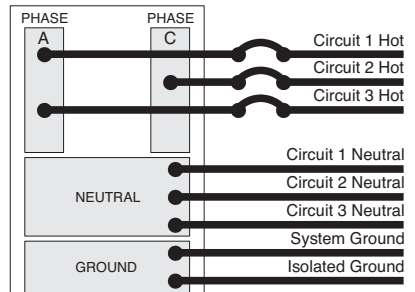

On a split-phase circuit panel, three circuits are distributed as shown.

Internode power infeed

brings building power to a power module.

► Specifying, page 108

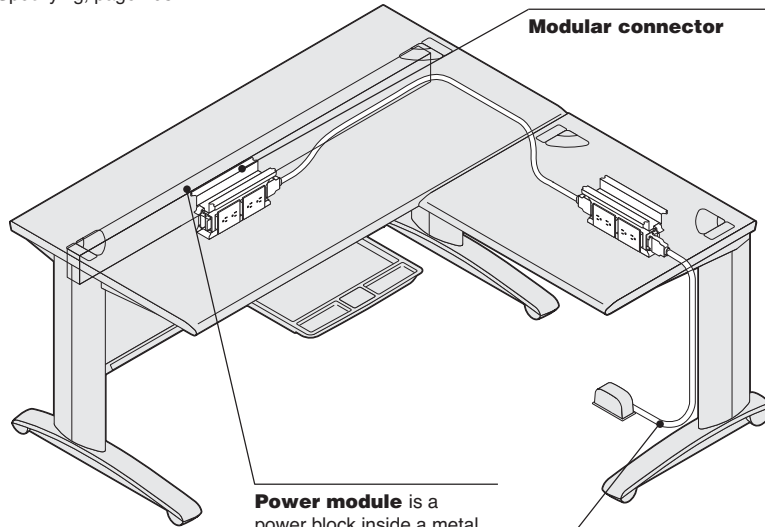

Modular connector

Power module is a power block inside a metal housing. It accepts modular receptacles.

Internode floor power infeed includes flexible liquid-tight harness that brings power from the monument in the floor of the building to an Internode power module.

► Page 108

Tip: Floor power infeed cannot be used in New York City. Use a multipurpose power infeed instead.

Product Details

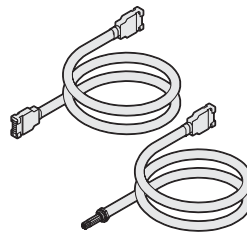

Multipurpose power infeed is made from flexible conduit. One end allows either a modular or hardwire connection to the building power source. The opposite end has a modular connector that attaches to a power module or harness-to-harness connector.

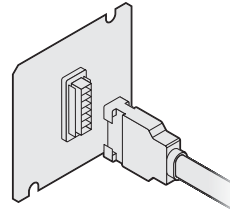

Modular connector receptacle is included with modular multipurpose power infeed to hardwire to a junction box. It allows modular connector to snap into position. This allows furniture to be disconnected, moved, and reconnected later.

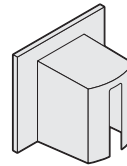

Modular infeed cover is available to conceal the connection in a visible location.

Flexible conduit is available in two lengths—12' or 24'.

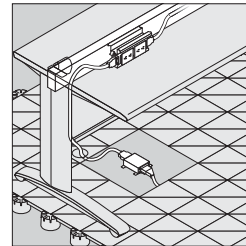

Harness from a Low-Profile Floor transition module can bring power to an Internode power module from the floor. Cables can also be routed to Internode from Low-Profile Floor.

► See *Architectural Solutions Specification Guide*.

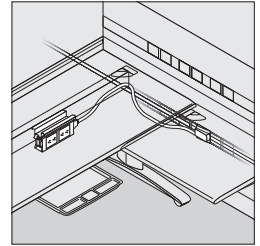

Harnesses are available to connect power modules in adjoining workstations.

Tip: When connecting power from one worksurface to another, harnesses may be routed through the power beam.

Wiring & Cabling

Chicago, New York City, and Los Angeles have special requirements.

Underwriters

Laboratory (UL) listed. These products have been designed to meet U.S. and Canadian national electrical and energy codes and most local building codes. Local electrical codes vary, so consult with your local authority having jurisdiction as they have final say if the products as installed are compliant with local code. Consult with a qualified electrician or electrical engineer for proper installation of all electrical equipment.

Surface Materials

Power block and housing

- 4793 Solar Black only

Infeed conduit

- 4793 Black plastic only

Internode Components

Internode components

provide external routing and access of power and communication to free-standing worksurfaces.

► Specifying, page 108

Mounting bracket

attaches to bottom of a worksurface and accommodates power or communication modules.

Convenience tri-receptacle

houses three black receptacles and extends power above or below the worksurface using a modular connector or a cord and plug.

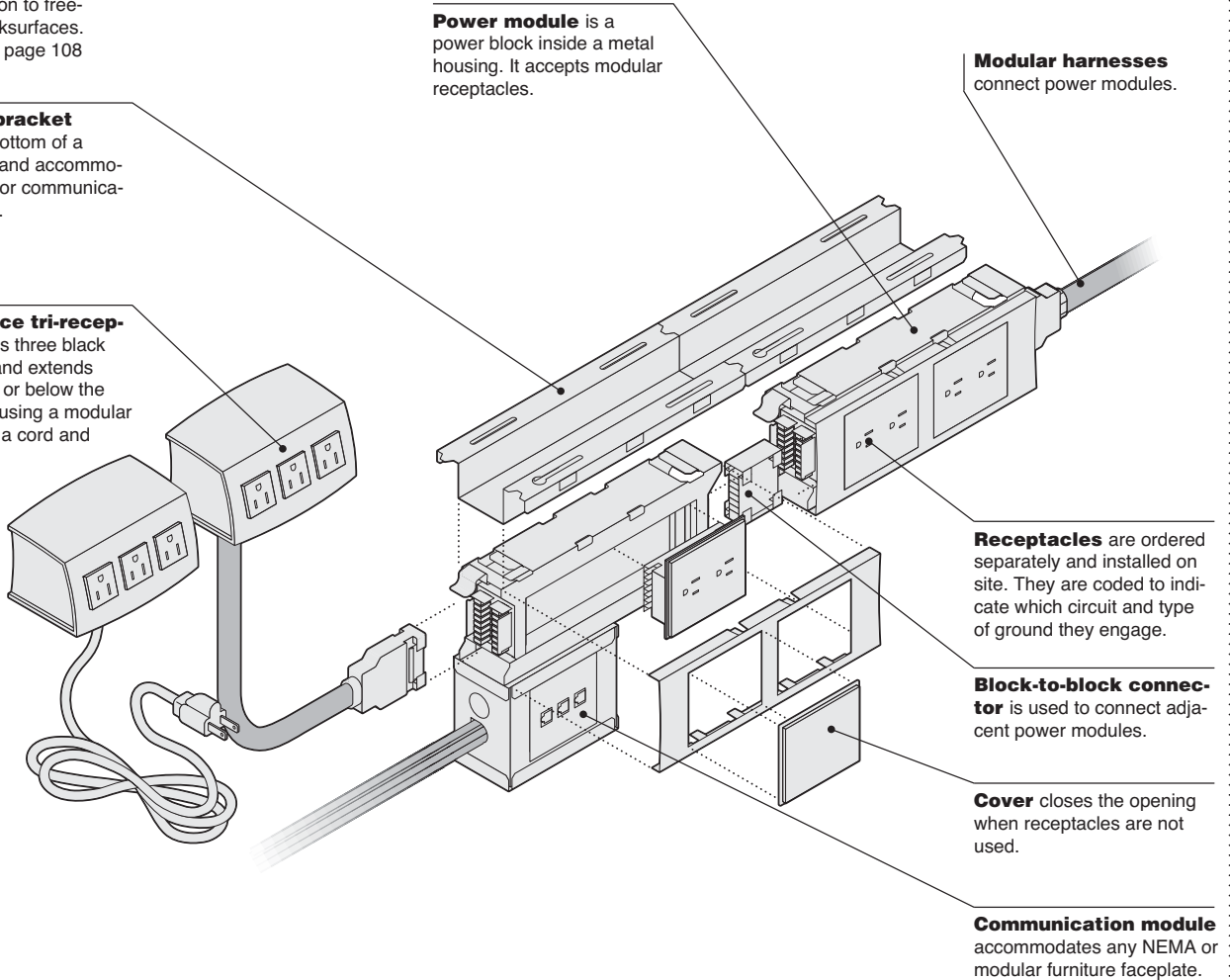

Actual Dimensions

	Power module	Communication module	Convenience tri-receptacle	Convenience communication outlet housing	Mounting bracket	Modular harnesses
Depth	3"	3"	2 ³ / ₄ "	2 ³ / ₄ "	4"	N.A.
Width	10"	5"	5 ¹ / ₄ "	5 ¹ / ₄ "	10"	N.A.
Height	3 ¹ / ₂ "	4"	2 ¹ / ₂ "	2 ¹ / ₂ "	1 ¹ / ₂ "	N.A.
Harness length	N.A.	N.A.	72"	N.A.	N.A.	12" to 144"
Power cord length	N.A.	N.A.	96"	N.A.	N.A.	N.A.

Product Details

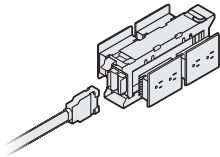

Power module accommodates up to four duplex receptacles—two on each side.

Covers are included for each side to fill the openings when receptacles are not used.

Tip: Power module is attached to the mounting bracket or another power module.

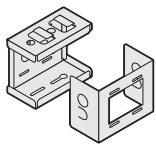

Communication module is a metal housing that supports NEMA or modular furniture faceplates. Faceplates are located on one side of the module. It can be attached to a power module to the mounting bracket, or directly onto underside of worksurface.

Convenience tri-receptacle houses three receptacles. It is designed to sit on a worksurface or attach beneath it with the below-worksurface mounting bracket.

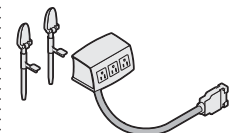

Convenience tri-receptacle with modular harness draws power from the end of a power module. Attachment clamps are included. Below-worksurface mounting bracket can be ordered separately.

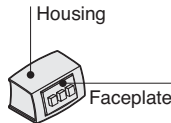

Convenience communication outlet housing supports customer-supplied modular furniture faceplates. It is designed to sit on a worksurface using the above-worksurface clamp kit. Attach beneath the worksurface by using below-worksurface mounting bracket. Order mounting hardware separately.

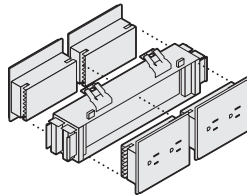

15-amp and 20-amp receptacles snap into power blocks. Tools are not required for installation.

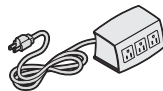

Convenience tri-receptacle with cord and plug has an 8' cord to drawer power. It can be attached to a power module to the mounting bracket, or directly onto underside of worksurface. Order mounting hardware separately.

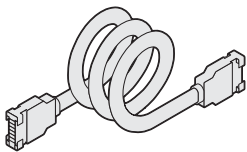

Modular harness must be specified to route power between two power modules.

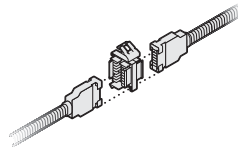

Harness-to-harness connector is available to join harnesses and extend the length of a run.

▶ Page 112

Connections

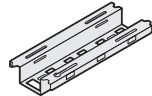

Mounting bracket attaches power or communication modules to the underside of a worksurface. Power module can be ordered with or without a mounting bracket. Communication module is standard without a mounting bracket. Mounting bracket can be ordered separately.

Tip: Communication module can also be installed directly to the underside of a worksurface without using a mounting bracket.

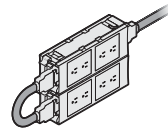

Vertically stack power and communication modules to increase the number of receptacles and communication outlets beneath a worksurface. Order a 22" modular harness to extend power to the stacked module.

Tip: Two communication modules can be attached beneath a power module.

Tip: If two power modules are stacked, it is recommended the communication modules be placed beside power modules instead of adding them below.

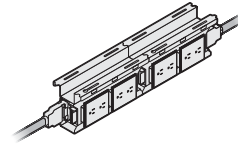

Horizontally connect power and communication modules to increase the number of receptacles and communication outlets beneath a worksurface. Order a block-to-block connector to join adjacent modules.

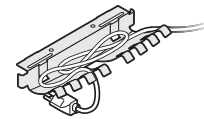

Internode cord and cable manager attaches to the underside of a worksurface or the mounting bracket to help organize and store cords and cables.

▶ Page 120

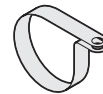

Internode harness clip attaches to the underside of a worksurface to route and manage modular harnesses.

▶ Page 120

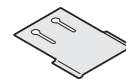

Below-worksurface mounting bracket

mounts convenience tri-receptacle or a convenience communication outlet housing to the underside of a worksurface.

Wiring & Cabling

Chicago, New York City, and Los Angeles have special requirements.

Underwriters

Laboratory (UL) listed. These products have been designed to meet U.S. and Canadian national electrical and energy codes and most local building codes. Local electrical codes vary, so consult with your local authority having jurisdiction as they have final say if the products as installed are compliant with local code. Consult with a qualified electrician or electrical engineer for proper installation of all electrical equipment.

Surface Materials

Power block and housing

- 4793 Solar Black only

Infeed conduit

- 4793 Black plastic only

Convenience tri-receptacle housing

- Plastic

Convenience tri-receptacles

- 6000 Black only

Convenience communication outlet housing

- Plastic

How to Calculate Power Needs

Use This to Determine How Many Power-Ins You'll Need

When planning a power network, you must calculate the amperage requirements of all your electrical components so you can provide sufficient electricity to power them.

If your usage is not known in advance:

The National Electrical Code (NEC) allows a maximum of 13 receptacles on each 20-amp circuit. This provides up to 39 receptacles for each 3-circuit power-in and 52 receptacles for each 4-circuit power-in. In Canada, the Canadian Electrical Code allows a maximum of 10 receptacles on each 15-amp circuit. This provides up to 30 receptacles for each 3-circuit power-in and 40 receptacles for each 4-circuit power-in.

If your usage is known in advance:

Add up the amperage used by each piece of equipment in the workstation. Whenever you reach 60 amps—20 amps times 3 circuits—(45 amps in Canada) from items that are likely to be used at the same time, you have reached the limit for a single power-in. Specify another power-in and continue until all equipment is powered.

▶ See table at right for typical and actual amperage usages for components.

To calculate amperage when the wattage of a device is known, divide watts by 120.

If the circuits will normally be subject to a continuous load (three or more hours of continuous use, such as lights or computers), the NEC requires that circuit capacity be “de-rated” by 20 percent. Therefore, treat circuits used for continuous loads as if they were rated at 16 amps (12 amps in Canada) instead of the regular 20 amps.

Try to anticipate future increases in power requirements and build some excess capacity into your plan.

Some appliances, such as large copiers, coffee makers, or space heaters require most of the current available on a circuit. It is recommended that such devices be supplied with their own dedicated circuit.

Local electrical codes vary. Consult a qualified electrical contractor or engineer for the proper planning of electrical circuits in your locale.

Requirements of Office Equipment in Amps

General Equipment (Typical Amperage)

A.C. adapter	0.05
Adding machine	0.05
Answering machine	0.08
Calculator	0.25
Clock	0.03
Coffee pot	10.00
Copy machine	15.00
Desk-top copiers	7.00 to 10.00
Stand-alone copiers	15.00
Electric eraser	0.25
Fan	1.00
Manuscript holder	0.75
Microfiche	0.85
Microwave	8.00 to 12.00
Pencil sharpener	0.25
Radio	0.05
Slide projector	2.00 to 6.00
Space heater, 1000 watts	8.50
Space heater, 1500 watts	12.50
Transcriber	0.15
Typewriter	1.50

Electronic Equipment (Typical Amperage)

Desk-top memory storage devices	0.08 to 12.00
Modems	0.15
Desk-top printers	1.20 to 5.00
Stand-alone printers	3.00 to 11.00
VDTs and PCs	0.08 to 4.80

Steelcase Lighting (Actual Amperage)

<i>Shelf light:</i>	
25"W, 17 watts	0.2
37"W, 25 watts	0.3
49"W, 32 watts	0.3

Peerless (50-watt Biax lamps with electronic ballasts):

1 lamp	0.5
2 lamps, 1 ballast	0.9
2 lamps, 2 ballasts	0.9
3 lamps	1.4

Locations with Special Requirements

Local electrical codes

vary. Consult a qualified electrical contractor or engineer for the proper installation of all electrical components. Here are the special conditions for the cities of Chicago, New York, Los Angeles, and San Francisco.

Chicago

Chicago electrical code requires the power distribution network to be hardwired on site. There is no hardwired version of Internode.

Shelf lights are available with a built-in circuit breaker to meet the Chicago electrical code.

New York City

New York City electrical code requires modular components to be installed on site by the electrician. Because all Internode modular components are field installed, they are acceptable for use in New York City. Internode convenience tri-receptacles are not approved for use in New York City.

New York City code also requires the electrician to complete the hardwired connection to the building's power supply. The Internode floor power infeed cannot be used in New York City. Use a hardwire multipurpose power infeed instead. The modular version of the multipurpose power infeed is not acceptable in New York City.

Los Angeles

All modular power components are acceptable for use in Los Angeles. Cord-connected power connections are not acceptable.

San Francisco

Cannot have exposed metal conduit.

Desktop receptacles cannot be housed in plastic casings.

Shelf Lights

Standard and Utility2

► Specifying, pages 122–125

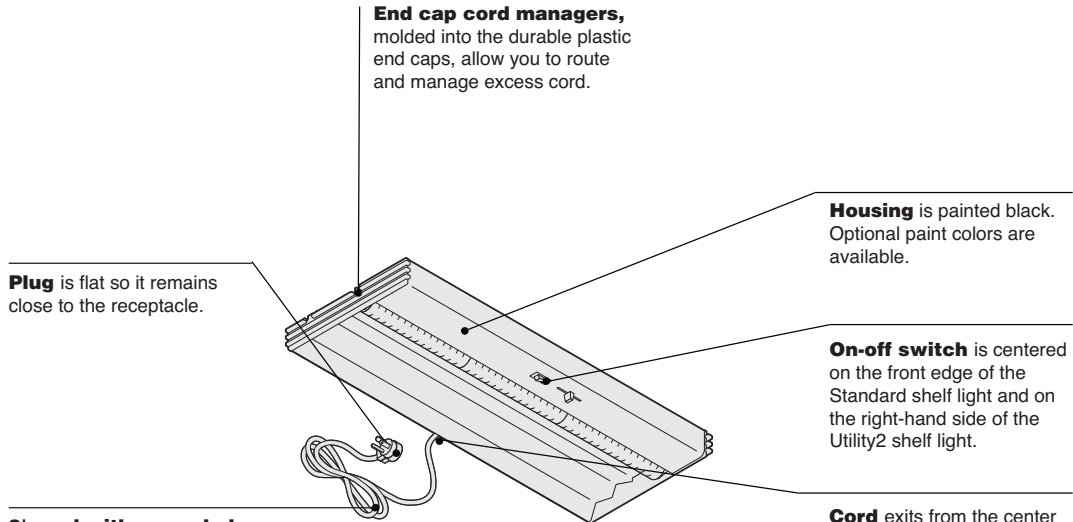

9' cord with grounded plug is factory installed. Length is maximum allowed by U.S. National Electrical Code. Cord with circuit breaker is available to meet the requirements of the Chicago code.

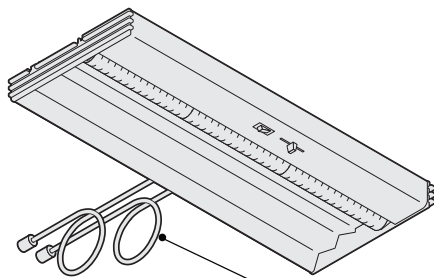

Daisy chain cords have modular connectors to link Standard shelf lights together. 78" daisy chain jumper cord is standard with select Utility2 lights.

Product Details

Shelf light includes the lamp, ballast, and either a 9' cord with three-prong plug or daisy-chain cords.

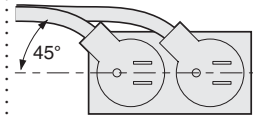

Plug configuration allows two Standard shelf lights to engage adjacent outlets in one receptacle.

Energy-saving T8 lamps have triphosphor coating for balanced color and pleasing light.

Connections

Shelf light mounts recessed or flush depending on design of overhead storage bin or shelf. Installation is done in the field.

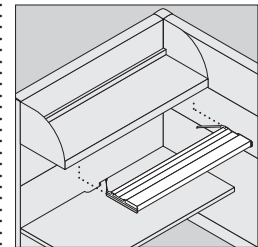

Universal bracket allows shelf light to be installed without tools under most metal overhead storage bins and shelves.



Daisy chain starter cord must be ordered separately when used with Standard shelf lights in a daisy chain application.

Daisy chain starter light with cord must be ordered when Utility2 shelf lights are used in a daisy chain application.

Actual Dimensions

	Standard	Utility2
Depth	9 ¹ / ₄ " (235 mm)	6 ⁷ / ₈ " (175 mm)
Width	24 ⁵ / ₈ ", 36 ⁵ / ₈ ", or 48 ⁵ / ₈ " (625 mm, 930 mm, or 1235 mm)	24 ⁵ / ₁₆ ", 36 ⁵ / ₁₆ ", or 48 ⁵ / ₁₆ " (617 mm, 922 mm, or 1227 mm)
Height	1 ³ / ₄ " (44 mm)	1 ⁵ / ₈ " (41 mm)

Width	Lamp width	Lamp wattage	Replacement lamps
24 ⁵ / ₈ "	24"	17 watts	F17T8-TL735
36 ⁵ / ₈ "	36"	25 watts	F25T8-TL735
48 ⁵ / ₈ "	48"	32 watts	F32T8-TL735

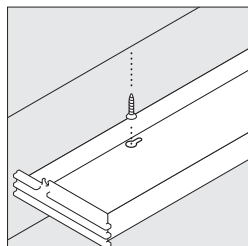

Keyhole slots in housing of fixture allow shelf light to be mounted beneath wood or laminate overhead storage bins and shelves using screws provided. Keyhole slots are also used to mount lights to overhead storage bins and shelves manufactured prior to August 1991.

Standard shelf competitive mounting package provides attachment hardware to mount Steelcase shelf lights on all major competitive furniture lines. Package includes screws and installation instructions.

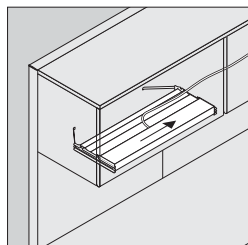

Shelf light can be mounted anywhere from side to side beneath over-head storage bin or shelf. The cord length is the only limitation.

Wiring & Cabling

Power drawn is approximately 1/2 amp.

Daisy chaining permits interconnecting up to six Standard shelf lights from a single power outlet. Utility2 light daisy chaining allows up to 10 fixtures.

▶ Page 122

Starter cord for Standard and starter light for Utility2 powers first light in a daisy chain and allows you to convert any daisy chain light for independent operation.

Electronic high-power-factor ballast that is roughly 45% more efficient than a normal-power-factor ballast is available on Standard and Utility2.

Normal-power-factor electronic ballasts are available on Utility2 shelf lights.

Batwing lens is available as an option on Utility2 shelf lights for applications where moderate improvement to light distribution is needed.

Surface Materials

Housing

- Black paint (standard)
- Paint colors (option)

Reflector

- White on Standard and silver on Utility2 shelf lights

Cord

- Black plastic only

End cap cord manager

- Black plastic only

Photometric Data

Standard

Initial horizontal footcandles for LSM24K
Worksurface rear

3"	88	85	78	67	55	42	31	22
6"	93	90	82	70	57	43	31	23
9"	91	88	81	69	56	41	30	21
12"	82	80	72	62	50	38	28	20
15"	69	67	61	53	43	33	24	18
18"	56	55	49	43	36	28	21	16
21"	41	40	37	32	27	22	17	13
24"	29	28	26	23	19	16	13	10
27"	19	19	18	16	14	12	10	8
30"	13	13	12	11	10	9	7	6

CL 3" 6" 9" 12" 15" 18" 21"

Worksurface front

Utility2

Initial horizontal footcandles for LSB24K2
Worksurface rear

3"	113	109	98	84	65	49	36	25
6"	129	123	112	93	73	53	37	26
9"	135	129	117	96	75	53	38	26
12"	127	119	107	89	68	49	36	25
15"	104	99	89	74	58	43	32	22
18"	78	76	68	56	44	34	26	19
21"	55	51	48	41	34	26	21	15
24"	36	36	31	29	24	18	15	11
27"	25	24	21	19	17	14	11	9
30"	17	16	15	13	11	10	8	7

CL 3" 6" 9" 12" 15" 18" 21"

Worksurface front

LED Shelf Lights

► Specifying, page 126

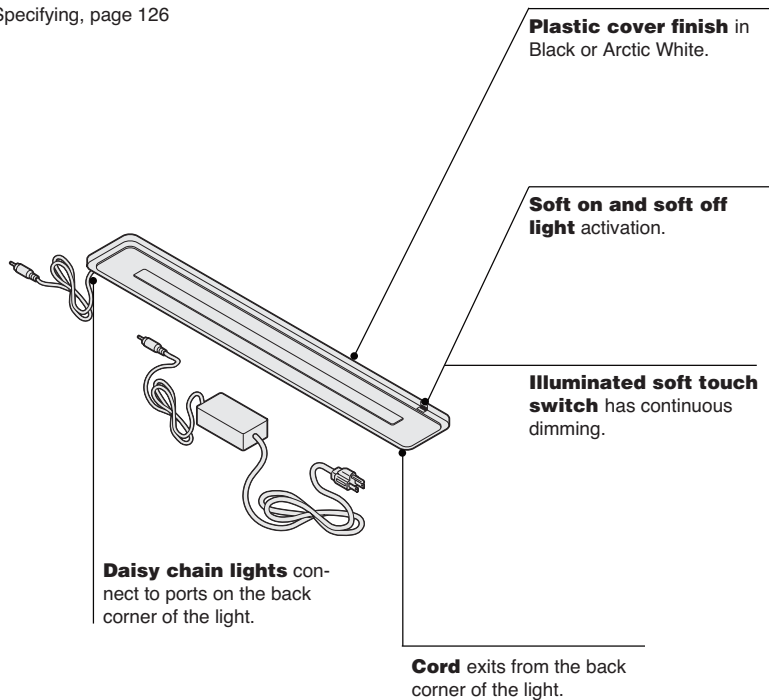

Product Details

Shelf light includes the lamp and power supply with cord set. Daisy chain primary light includes lamp and larger power supply to support up to three lights. Daisy chain secondary light includes lamp and daisy chain cord set.

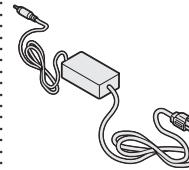

Power supply for LED daisy chain starter light uses a 60 watt modular cord with standard two prong plug, an integrated low voltage cord, and a connector to attach to light. A 15 watt power supply is used on the LED standard light, it is 9' long with a two prong driver plug.

Tip: Energy saving mini-LEDs greatly reduce power use.

Connections

Shelf light mounts recessed or flush depending on design of overhead storage bin or shelf. Installation is done in the field.

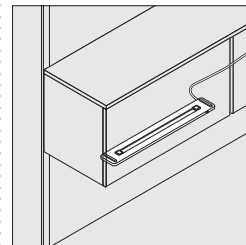
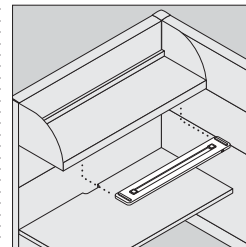

Magnetic mounting allows shelf light to be installed without tools under most metal overhead storage bins and shelves. This mounting allows the light to be mounted to most competitive steel bins and shelves.

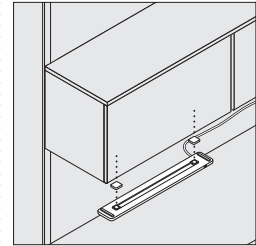

Optional fastener kit allows shelf light to be mounted to wood or aluminum shelves.

Wiring & Cabling

Shelf light includes the lamp and power supply with cord set. Daisy chain starter light includes lamp and larger power supply to support up to three lights. Daisy chain secondary light includes lamp and daisy chain cord set.

Power supply for LED daisy chain starter light uses a 60 watt modular cord with standard two prong plug, an integrated low voltage cord, and a connector to attach to light. A 15 watt power supply is used on the LED standard light, it is 9' long with a two prong driver plug.

Tip: Daisy chain starter light comes with a 60 watt power supply to support up to three lights. Daisy chain secondary lights do not come with a power supply, but instead come with a daisy chain cord set.

Surface Materials

Housing

- 6000 Black
- 6009 Arctic White

Reflector

- Clear anodized aluminum only

Cord

- Black plastic only

Actual Dimensions

Depth 2⁵/₈"

Width 18¹/₈"

Height 1/2"

Power Supply 60 Watt Cord Set (11')

-Line voltage cord: 6'

-Low voltage cord: 5'

Power Supply 15 Watt Cord

-9' with two prong driver plug

Photometric Data**LED Shelf Light**Initial horizontal footcandles for LSL18
Worksurface rear

3"	83	80	71	58	45	32	23	17
6"	94	90	78	64	48	34	24	18
9"	98	94	81	65	49	35	25	17
12"	93	89	75	61	46	34	24	17
15"	78	74	63	53	40	30	22	15
18"	59	57	50	43	32	25	18	14
21"	40	41	36	32	25	19	15	11
24"	28	27	24	22	18	14	11	9
27"	18	17	16	14	12	10	8	7
30"	11	10	10	9	8	7	6	5
CL	3"	6"	9"	12"	15"	18"	21"	

Worksurface front

LED Personal Task Lights

► Specifying, page 127

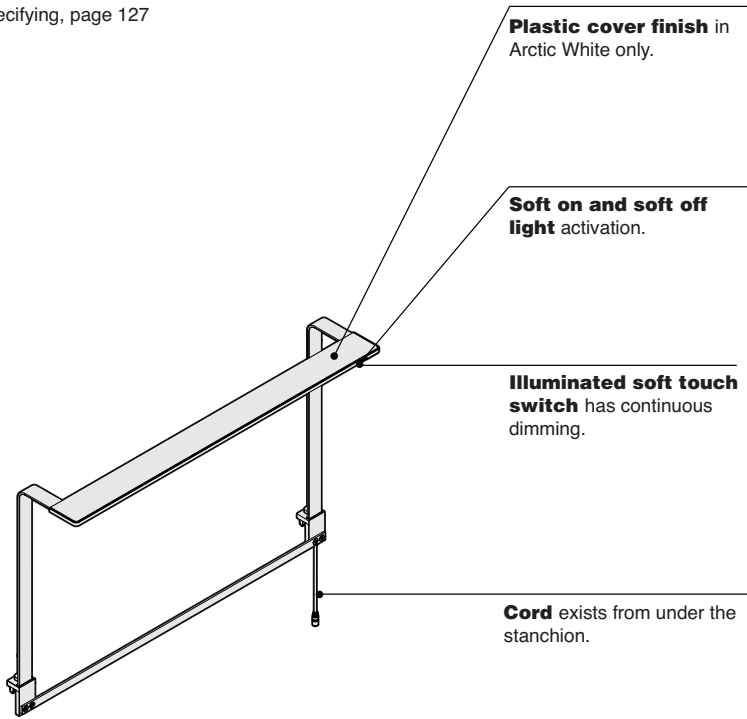

Plastic cover finish in Arctic White only.

Soft on and soft off light activation.

Illuminated soft touch switch has continuous dimming.

Cord exists from under the stanchion.

Product Details

Personal task light includes the lamp and power supply with cord set. Rail-mounted version includes rail brackets. Non rail-mounted version includes Universal Mounting brackets.

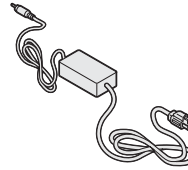

Power supply uses a modular cord with standard two prong plug, an integrated low voltage cord, and a connector to attach to light.

Tip: Energy saving mini-LEDs greatly reduce power use.

Connections

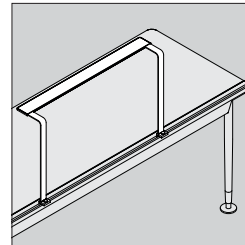

LED personal task light mounts directly to the rail systems of c:scape, Frame-One, Elective Elements, Impact, Turnstone Campfire Big Table, and Details SOTO rail.

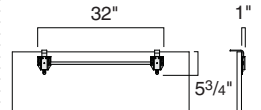
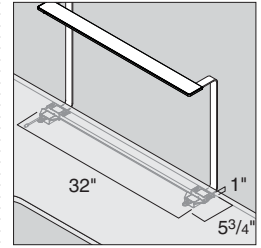

Non rail-mounted LED personal task lights will not work on worksurfaces with knife edge that is longer than 1 1/4", or with modesty panels or modesty screens closer than 6" from the back edge.

Wiring & Cabling

Personal task light includes the lamp and power supply with cord set.

Power supply uses a modular cord with standard two prong plug, an integrated low voltage cord, and a connector to attach to light.

Surface Materials

Housing

- 6009 Arctic White plastic only

Fixture and Stanchions

- 4231 Arctic White
- 4710 Low Gloss Black
- 4799 Platinum Metallic

Cord

- Black plastic only

Actual Dimensions

Depth 6"

Width 30"

Height 17"

Power Supply Cord Set (12')

-Line voltage cord: 6'

-Low voltage cord: 6'

Photometric Data

LED Personal Task Lights
Initial horizontal footcandles for LPTL30 and LPTL30NR
Worksurface rear

0"	15	14	13	12	11	9	6	6	5	4	3	2	2
3"	21	20	18	17	15	13	11	8	6	5	3	3	2
6"	31	31	29	26	23	19	15	12	9	7	5	3	2
9"	51	50	46	42	36	29	23	18	13	9	6	4	3
12"	82	79	73	64	53	43	32	23	16	11	7	5	3
15"	109	105	96	83	68	53	39	27	19	12	8	6	4
18"	105	102	93	81	66	51	37	27	18	12	9	6	4
21"	76	75	69	59	50	39	30	22	16	11	7	5	4
24"	48	47	44	39	33	27	21	16	12	9	6	5	3
27"	29	28	27	24	21	17	14	11	9	7	5	4	3
30"	18	18	17	16	14	12	10	8	7	5	4	3	2
CL	3"	6"	9"	12"	15"	18"	21"	24"	27"	30"	33"	36"	

Worksurface front

Daisy Chaining

For Standard and Utility2 Lights

Daisy chaining shelf lights together extends power from one fixture to another within workstations to help keep receptacles clear for other uses.

For Standard shelf lights, starter cord is required with daisy chain cords to bring power to the first shelf light in a daisy chain so there's no need to designate where each fixture will be used within the chain.

Power will not be interrupted in a chain even if one of the shelf lights is turned off or its lamp has burned out. That's because the path of power through the chain doesn't pass through the lamps or switches.

Additions to a chain are possible at any time by adding a jumper cord.

For Utility2 lights, connect the power cord **1** between the first light and the wall receptacle. Connect the jumper cord **2** between the lights. Maximum distance between receptacles for 78" jumper is 74".
Tip: Connect up to 10 fixtures maximum. Voltage and current rating of fixture is 120 volt, .75 amps.
 Starter light is required with daisy chain lights to bring power to the first light in the daisy chain.

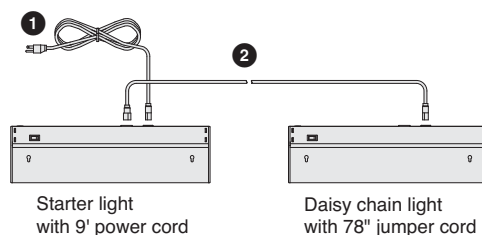
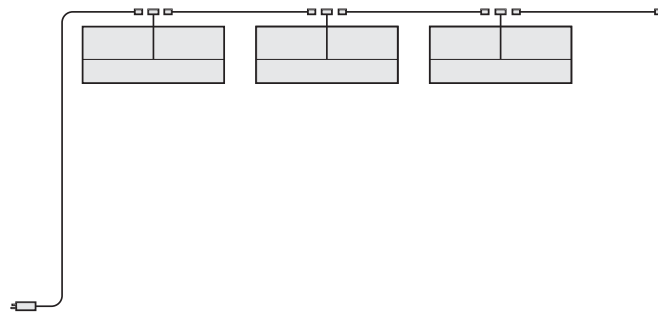
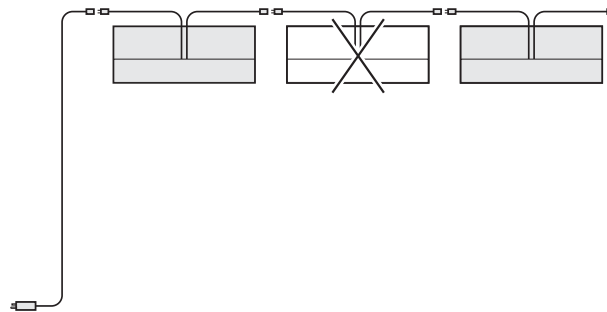
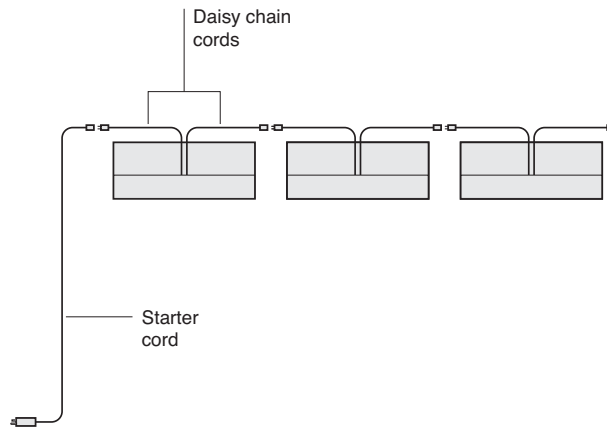

Tip: Daisy chaining is not allowed in Chicago. Local electrical codes vary, so you should consult a qualified electrical contractor or engineer for proper installation of all electrical equipment.

Tip: Overhead cabinets and shelves provide a recessed area for shelf lights. They are not designed to conceal cords when daisy chaining.

Tip: When using upmount brackets with overhead storage and daisy chaining lights, use the open design upmount bracket for better cord management.

Specifying Ellipse

Desks	
24"D Desks	52
30"D Desks	54
36"D Desks	56
30"D Desks with Overhead Cabinet	58
Returns	60
Corner Desks	61
Radius Junction Tops	62
Triangular Junction Tops	63
Left-Hand Corner Conference Tables	64
Right-Hand Corner Conference Tables	65
Round and Rectangular Conference Tables	66
Supports	67
Screens	68
Transaction Tops	69
Accessories	70
Universal Storage	
Universal Fixed Pedestals	72
Universal Fixed to Freestanding Pedestal Conversion Kits	74
Universal Mobile Pedestals	76
Universal Hanging Pedestal	79
Universal Lateral Files	80
Universal Combination Cabinets	84
Universal Storage Cabinets	90
Universal Wardrobe Cabinets	94
Storage Tops, Shelves, and Accessories	97
Ellipse-Style Lateral File Tops	107
Internode Power and Communication Components	108
Standard Shelf Lights	122
Utility2 Shelf Lights	124
LED Shelf Lights	126
LED Personal Task Lights	127

24"D Desks ✕4/16

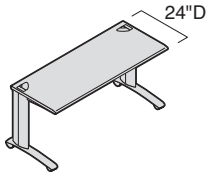

Standard Includes	Required to Specify
<ul style="list-style-type: none"> ▶ Need help? Product details, page 18 • Left- and right-hand C-legs: paint price group 1 • Power beam: paint price group 1 • Modesty panel, if selected: paint price group 1 • Worksurface: laminate • Worksurface ends: plastic default • Two grommets: plastic default • Leg trim strips and glide covers: plastic 	<ol style="list-style-type: none"> 1 Style number 2 Paint color number for legs, power beam, and modesty panel, if selected 3 Color number for worksurface 4 Plastic color number for leg trim strips and glide covers 5 Options, if selected (see below) <p>▶ See <i>Surface Materials</i>, page 130.</p>

Options	U.S. Price	Required to Specify
Surface Materials		
Desks without modesty panel		
• Paint price group 1	No cost	Specify paint color number.
• Paint price group 2	+\$ 38	Specify paint color number.
• Paint price group 3	+\$ 65	Specify paint color number.
• Open Line laminate	+\$ 67 plus cost of laminate	▶ See <i>Surface Materials Reference Manual</i> .
Desks with modesty panel		
• Paint price group 1	No cost	Specify paint color number.
• Paint price group 2	+\$ 66	Specify paint color number.
• Paint price group 3	+\$113	Specify paint color number.
• Open Line laminate	+\$ 67 plus cost of laminate	▶ See <i>Surface Materials Reference Manual</i> .
I-Legs for Junction Tops		
• On left-hand side of worksurface	No cost	Specify with ACAC2400L9.
• On right-hand side of worksurface	No cost	Specify with ACAC2400R5.
• On both sides of worksurface	No cost	Specify with ACAC2400L9 and ACAC2400R5.
Adjustable-Height Legs		
• Available on desks with modesty panel only	+\$674	Replace the last character of the style number with a letter A . Example: Change ADXM2430L B to ADXM2430L A . ▶ Page 28
Related Products		
• Supports		▶ Page 67
• Screens		▶ Page 68
• Transaction tops		▶ Page 69
• Accessories		▶ Page 70
• Internode power and communication components		▶ Page 108

Tip: I-leg must be specified in place of a desk's standard leg wherever a desk will be linked to a junction top. 24"D desks do not connect to corner conference tables.

For Canadian Pricing
Multiply U.S. Price by the Canadian price factor.
▶ See page 1 for details.

✕4/16 = Last order entry
April 17, 2016

Specification Information

Dimensions			Style Number	U.S. Base Price
D	W	H		

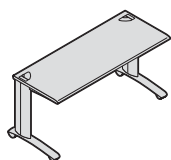

Desks without Modesty Panel

24"	30"	28½"	ADXP2430L7 ✕4/16	\$ 887
24"	36"	28½"	ADXP2436L9 ✕4/16	\$ 930
24"	42"	28½"	ADXP2442L4 ✕4/16	\$ 974
24"	48"	28½"	ADXP2448L6 ✕4/16	\$1015
24"	60"	28½"	ADXP2460L6 ✕4/16	\$1102
24"	66"	28½"	ADXP2466L3 ✕4/16	\$1214
24"	72"	28½"	ADXP2472L3 ✕4/16	\$1257

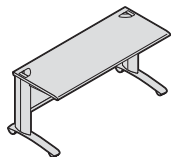

Desks with Modesty Panel

24"	30"	28½"	ADXM2430L8 ✕4/16	\$1003
24"	36"	28½"	ADXM2436L0 ✕4/16	\$1054
24"	42"	28½"	ADXM2442L5 ✕4/16	\$1108
24"	48"	28½"	ADXM2448L7 ✕4/16	\$1162
24"	60"	28½"	ADXM2460L7 ✕4/16	\$1265
24"	66"	28½"	ADXM2466L5 ✕4/16	\$1392
24"	72"	28½"	ADXM2472L4 ✕4/16	\$1441

Tip: Modesty panels available through customer service parts can be added to desks without modesty panels.

Specifying

 **For Canadian Pricing**
 Multiply U.S. Price by the Canadian price factor.
 ▶ See page 1 for details.

✕4/16 = Last order entry
 April 17, 2016

30"D Desks ✕4/16

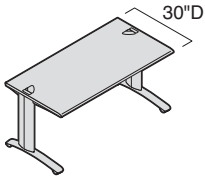

Standard Includes	Required to Specify
<ul style="list-style-type: none"> ▶ Need help? Product details, page 18 • Left- and right-hand T-legs: paint price group 1 • Power beam: paint price group 1 • Modesty panel, if selected: paint price group 1 • Worksurface: laminate • Worksurface ends: plastic default • Two grommets: plastic default • Leg trim strips and glide covers: plastic 	<ol style="list-style-type: none"> 1 Style number 2 Paint color number for legs, power beam, and modesty panel, if selected 3 Color number for worksurface 4 Plastic color number for leg trim strips and glide covers 5 Options, if selected (see below) <ul style="list-style-type: none"> ▶ See <i>Surface Materials</i>, page 130.

Options	U.S. Price	Required to Specify
Surface Materials	Desks without modesty panel <ul style="list-style-type: none"> • Paint price group 1 No cost • Paint price group 2 +\$ 38 • Paint price group 3 +\$ 65 • Open Line laminate +\$ 67 plus cost of laminate 	Specify paint color number. Specify paint color number. Specify paint color number. ▶ See <i>Surface Materials Reference Manual</i> .
	Desks with modesty panel <ul style="list-style-type: none"> • Paint price group 1 No cost • Paint price group 2 +\$ 66 • Paint price group 3 +\$113 • Open Line laminate +\$ 67 plus cost of laminate 	Specify paint color number. Specify paint color number. Specify paint color number. ▶ See <i>Surface Materials Reference Manual</i> .
I-Legs for Junction Tops or Corner Conference Tables	<ul style="list-style-type: none"> • On left-hand side of worksurface No cost • On right-hand side of worksurface No cost • On both sides of worksurface No cost 	Specify with <i>ACAC3036L3</i> . Specify with <i>ACAC3036R9</i> . Specify with <i>ACAC3036L3 and ACAC3036R9</i> .
High-Capacity I-legs for Junction Tops or Corner Conference Tables	<ul style="list-style-type: none"> • On left-hand side of worksurface No cost • On right-hand side of worksurface No cost • On both sides of worksurface No cost 	Specify with <i>ACAC3036L2</i> . Specify with <i>ACAC3036R8</i> . Specify with <i>ACAC3036L2 and ACAC3036R8</i> .
Adjustable-Height Legs	<ul style="list-style-type: none"> • Available on desks with modesty panel only +\$674 	Replace the last character of the style number with a letter A . Example: Change ADXM2430L8 to ADXM2430LA . ▶ Page 28
Related Products	<ul style="list-style-type: none"> • Supports • Screens • Transaction tops • Accessories • Internode power and communication components 	<ul style="list-style-type: none"> ▶ Page 67 ▶ Page 68 ▶ Page 69 ▶ Page 70 ▶ Page 108

Tip: I-leg must be specified in place of a desk's standard leg wherever a desk will be linked to a junction top or corner conference table.

For Canadian Pricing
 Multiply U.S. Price by the Canadian price factor.
 ▶ See page 1 for details.

✕4/16 = Last order entry
 April 17, 2016

Specification Information

Dimensions			Style Number	U.S. Base Price
D	W	H		

Desks without Modesty Panel

30"	30"	28½"	ADXP3030L0 ✕4/16	\$ 948
30"	36"	28½"	ADXP3036L2 ✕4/16	\$1001
30"	42"	28½"	ADXP3042L7 ✕4/16	\$1049
30"	48"	28½"	ADXP3048L9 ✕4/16	\$1098
30"	54"	28½"	ADXP3054L4 ✕4/16	\$1146
30"	60"	28½"	ADXP3060L9 ✕4/16	\$1198
30"	66"	28½"	ADXP3066L6 ✕4/16	\$1331
30"	72"	28½"	ADXP3072L6 ✕4/16	\$1379

Desks with Modesty Panel

30"	30"	28½"	ADXM3030L1 ✕4/16	\$1064
30"	36"	28½"	ADXM3036L3 ✕4/16	\$1125
30"	42"	28½"	ADXM3042L8 ✕4/16	\$1183
30"	48"	28½"	ADXM3048L0 ✕4/16	\$1245
30"	54"	28½"	ADXM3054L5 ✕4/16	\$1300
30"	60"	28½"	ADXM3060L0 ✕4/16	\$1361
30"	66"	28½"	ADXM3066L8 ✕4/16	\$1509
30"	72"	28½"	ADXM3072L7 ✕4/16	\$1563

Specifying

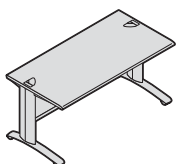
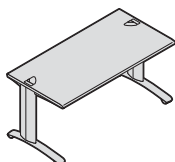

For Canadian Pricing
 Multiply U.S. Price by the Canadian price factor.
 ▶ See page 1 for details.

✕4/16 = Last order entry
 April 17, 2016

36"D Desks ✕4/16

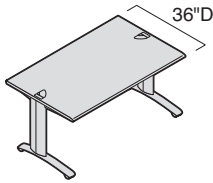

Tip: 36"D desks do not connect to junction tops or corner conference tables.

Tip: I-legs can be used when desks are connected in line to form conference room or training room configurations. In these I-leg configurations, desk-mounted pedestals cannot be used. Use mobile pedestals.

Standard Includes	Required to Specify
<ul style="list-style-type: none"> ▶ Need help? Product details, page 18 • Left- and right-hand T-legs: paint price group 1 • Power beam: paint price group 1 • Modesty panel, if selected: paint price group 1 • Worksurface: laminate • Worksurface ends: plastic default • Two grommets: plastic default • Leg trim strips and glide covers: plastic 	<ol style="list-style-type: none"> 1 Style number 2 Paint color number for legs, power beam, and modesty panel, if selected 3 Color number for worksurface 4 Plastic color number for leg trim strips and glide covers 5 Options, if selected (see below) <p>▶ See <i>Surface Materials</i>, page 130.</p>

Options	U.S. Price	Required to Specify
<p>Surface Materials</p> <p>Desks without modesty panel</p> <ul style="list-style-type: none"> • Paint price group 1 No cost • Paint price group 2 +\$ 38 • Paint price group 3 +\$ 65 • Open Line laminate +\$ 67 plus cost of laminate <p>Desks with modesty panel</p> <ul style="list-style-type: none"> • Paint price group 1 No cost • Paint price group 2 +\$ 66 • Paint price group 3 +\$113 • Open Line laminate +\$ 67 plus cost of laminate 		<p>Specify paint color number.</p> <p>Specify paint color number.</p> <p>Specify paint color number.</p> <p>▶ See <i>Surface Materials Reference Manual</i>.</p> <p>Specify paint color number.</p> <p>Specify paint color number.</p> <p>Specify paint color number.</p> <p>▶ See <i>Surface Materials Reference Manual</i>.</p>
<p>I-Legs</p> <ul style="list-style-type: none"> • On left-hand side of worksurface No cost • On right-hand side of worksurface No cost • On both sides of worksurface No cost 		<p>Specify with ACAC3036L3.</p> <p>Specify with ACAC3036R9.</p> <p>Specify with ACAC3036L3 and ACAC3036R9.</p>
<p>High-Capacity I-Legs</p> <ul style="list-style-type: none"> • On left-hand side of worksurface No cost • On right-hand side of worksurface No cost • On both sides of worksurface No cost 		<p>Specify with ACAC3036L2.</p> <p>Specify with ACAC3036R8.</p> <p>Specify with ACAC3036L2 and ACAC3036R8.</p>
<p>Related Products</p> <ul style="list-style-type: none"> • Supports • Screens • Transaction tops • Accessories • Internode power and communication components 		<p>▶ Page 67</p> <p>▶ Page 68</p> <p>▶ Page 69</p> <p>▶ Page 70</p> <p>▶ Page 108</p>

For Canadian Pricing
 Multiply U.S. Price by the Canadian price factor.
 ▶ See page 1 for details.

✕4/16 = Last order entry
 April 17, 2016

Specification Information

Dimensions			Style Number	U.S. Base Price
D	W	H		

Desks without Modesty Panel

36"	60"	28½"	ADXP3660L5 ✕4/16	\$1298
36"	72"	28½"	ADXP3672L2 ✕4/16	\$1508

Desks with Modesty Panel

36"	60"	28½"	ADXM3660L6 ✕4/16	\$1461
36"	72"	28½"	ADXM3672L3 ✕4/16	\$1692

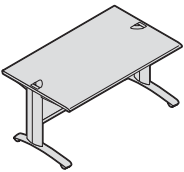
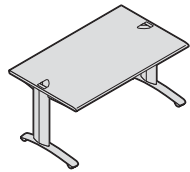

Tip: Modesty panels available through customer service parts can be added to desks without modesty panels.

Specifying

 **For Canadian Pricing**
 Multiply U.S. Price by the Canadian price factor.
 ▶ See page 1 for details.

✕4/16 = Last order entry
 April 17, 2016

30"D Desks with Overhead Cabinet X4/16

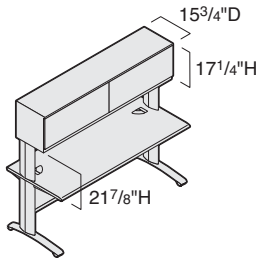

Tip: Overhead cabinets can not be mounted onto standard Ellipse desks.

Tip: I-legs and High-Capacity I-legs must be specified in place of a desk's standard T-legs whenever a desk will be linked to a junction top or corner conference table. I-legs and High-Capacity I-legs can not be used on a desk with overhead cabinet without an adjacent unit attached.

Tip: Screens, if specified, must be one size smaller in width than the worksurface. Example: Order 48"W for 54"W worksurface, 54"W for 60"W worksurface, etc.

Standard Includes	Required to Specify
<ul style="list-style-type: none"> Need help? Product details, page 19 Left- and right-hand T-legs: paint price group 1 Power beam: paint price group 1 Modesty panel: paint price group 1 Worksurface: laminate Worksurface ends: plastic default Two grommets: plastic default Leg trim strips and glide covers: plastic Overhead storage cabinet with lift-up door: paint price group 1 Recess beneath overhead cabinet to accommodate shelf light Overhead cabinet shelf backstop Lock, keyed random: 9201 Polished Chrome 	<ol style="list-style-type: none"> Style number Paint color number for legs, power beam, modesty panel, and overhead cabinet, if selected Laminate color number for worksurface Plastic color number for leg trim strips and glide covers Options, if selected (see below) <p>▶ See <i>Surface Materials</i>, page 130.</p>

Options	U.S. Price	Required to Specify
Surface Materials <ul style="list-style-type: none"> Desks with modesty panel Paint price group 1 Paint price group 2 Paint price group 3 Open Line laminate 	<ul style="list-style-type: none"> No cost +\$125 +\$214 +\$ 67 plus cost of laminate 	<ul style="list-style-type: none"> Specify paint color number. Specify paint color number. Specify paint color number. <p>▶ See <i>Surface Materials Reference Manual</i>.</p>
I-Legs for Junction Tops or Corner Conference Tables <ul style="list-style-type: none"> On left-hand side of worksurface On right-hand side of worksurface On both sides of worksurface 	<ul style="list-style-type: none"> No cost No cost No cost 	<ul style="list-style-type: none"> Specify with <i>I-leg</i> on left-hand side. Specify with <i>I-leg</i> on right-hand side. Specify with <i>I-leg</i> on left-hand side and <i>I-leg</i> on right-hand side.
High-Capacity I-Legs for Junction Tops or Corner Conference Tables <ul style="list-style-type: none"> On left-hand side of worksurface On right-hand side of worksurface On both sides of worksurface 	<ul style="list-style-type: none"> No cost No cost No cost 	<ul style="list-style-type: none"> Specify with <i>high-capacity I-leg</i> on left-hand side. Specify with <i>high-capacity I-leg</i> on right-hand side. Specify with <i>high-capacity I-leg</i> on left-hand side and <i>high capacity I-leg</i> on right-hand side.
Door Mechanism <ul style="list-style-type: none"> Assist mechanism on standard door 	<ul style="list-style-type: none"> +\$175 per door 	<ul style="list-style-type: none"> Specify with <i>assist mechanism</i> on standard door.
Shelf Accessories <ul style="list-style-type: none"> Four dividers: white plastic 	<ul style="list-style-type: none"> +\$ 45 	<ul style="list-style-type: none"> Specify with <i>dividers</i>.
Lock and Keying <ul style="list-style-type: none"> Lock Ember Chrome Keying Factory- and field-installed keying 	<ul style="list-style-type: none"> No cost 	<ul style="list-style-type: none"> Specify with <i>9250 Ember Chrome lock</i>. ▶ Page 142

Related Products <ul style="list-style-type: none"> Supports Screens Accessories Internode power and communication components Shelf lights 	<ul style="list-style-type: none"> ▶ Page 67 ▶ Page 68 ▶ Page 70 ▶ Page 108 ▶ Pages 122–125
--	--

 **For Canadian Pricing**
Multiply U.S. Price by the Canadian price factor.
▶ See page 1 for details.

X4/16 = Last order entry
April 17, 2016

Specification Information

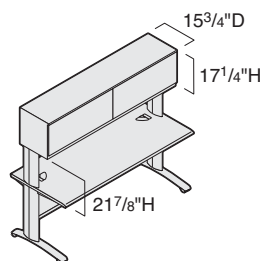

Dimensions			Number of Doors	New Style Number	Old Style Number	U.S. Base Price
D	W	H				
30"	42"	67 ⁵ / ₈ "	1	ADBB42 4/16	ADXM2242LOC	\$3432
30"	48"	67 ⁵ / ₈ "	1	ADBB48 4/16	ADXM2248LOC	\$3584
30"	54"	67 ⁵ / ₈ "	2	ADBB54 4/16	ADXM2254LOC	\$3685
30"	60"	67 ⁵ / ₈ "	2	ADBB60 4/16	ADXM2260LOC	\$3783
30"	72"	67 ⁵ / ₈ "	2	ADBB72 4/16	ADXM2272LOC	\$4158

Specifying

 **For Canadian Pricing**
Multiply U.S. Price by the
Canadian price factor.
▶ See page 1 for details.

~~4/16~~ = Last order entry
April 17, 2016

Returns

Tip: Return filler is available to fill the gap between the contoured front edges of a desk and the end of a return.
 ▶ Page 70





Standard Includes		Required to Specify
▶ Need help? Product details, page 18	<ul style="list-style-type: none"> • Left- or right-hand C-leg: paint price group 1 • Worksurface: laminate • Worksurface ends: plastic default • Two grommets: plastic default • Leg trim strip and glide cover: plastic • Attachment brackets: black paint only 	<ol style="list-style-type: none"> 1 Style number 2 Paint color number for leg 3 Laminate color number for worksurface 4 Plastic color number for leg trim strip and glide cover 5 Options, if selected (see below) ▶ See <i>Surface Materials</i> , page 130.

Options	U.S. Price	Required to Specify
Surface Materials <ul style="list-style-type: none"> • Paint price group 1 • Paint price group 2 • Paint price group 3 • Open Line laminate 	No cost +\$19 +\$33 +\$67 plus cost of laminate	Specify paint color number. Specify paint color number. Specify paint color number. ▶ See <i>Surface Materials Reference Manual</i> .
Related Products <ul style="list-style-type: none"> • Supports • Screens • Transaction tops • Accessories • Internode power and communication components 		▶ Page 67 ▶ Page 68 ▶ Page 69 ▶ Page 70 ▶ Page 108

Specification Information

Dimensions			Style Number	U.S. Base Price
D	W	H		
:	:	:	:	:

Left-Hand Returns

24"	30"	28½"	ARAL2430L0 	\$683
24"	36"	28½"	ARAL2436L2 	\$705
24"	42"	28½"	ARAL2442L7 	\$726
24"	48"	28½"	ARAL2448L9 	\$747
24"	60"	28½"	ARAL2460L9 	\$787
:	:	:	:	:

Right-Hand Returns

24"	30"	28½"	ARAR2430L8 	\$683
24"	36"	28½"	ARAR2436L0 	\$705
24"	42"	28½"	ARAR2442L5 	\$726
24"	48"	28½"	ARAR2448L7 	\$747
24"	60"	28½"	ARAR2460L7 	\$787
:	:	:	:	:

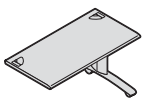
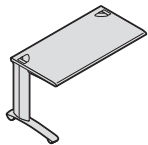

For Canadian Pricing
 Multiply U.S. Price by the Canadian price factor.
 ▶ See page 1 for details.

 = Last order entry
 April 17, 2016

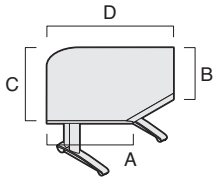

Standard Includes		Required to Specify
<ul style="list-style-type: none"> ▶ Need help? Product details, page 22 	<ul style="list-style-type: none"> • Left- and right-hand legs: paint price group 1 • Power beam: paint price group 1 • Worksurface: laminate • Worksurface ends: Plastic default • Leg trim strips and glide covers: plastic 	<ol style="list-style-type: none"> 1 Style number 2 Paint color number for legs and power beam 3 Color number for worksurface 4 Plastic color number for leg trim strip and glide cover 5 Options, if selected (see below) <p>▶ See <i>Surface Materials</i>, page 130.</p>

Options	U.S. Price	Required to Specify
Surface Materials <ul style="list-style-type: none"> • Paint price group 1 • Paint price group 2 • Paint price group 3 • Open Line laminate 	No cost +\$ 66 +\$113 +\$ 67 plus cost of laminate	Specify paint color number. Specify paint color number. Specify paint color number. ▶ See <i>Surface Materials Reference Manual</i> .
Related Products <ul style="list-style-type: none"> • 24"D and 30"D desks • Internode power and communication components 		▶ Pages 52–55 ▶ Page 108

Specification Information

Dimensions				Front Edge	Height	Style Number	U.S. Base Price
A	B	C	D				
Laminate							
24"	24"	42"	42"	25½"	28½"	ADCP2442L0 X4/16	\$1722
24"	30"	48"	42"	25½"	28½"	ADCP2448L1 X4/16	\$2132
30"	24"	42"	48"	25½"	28½"	ADCP3042L2 X4/16	\$2132
30"	30"	48"	48"	25½"	28½"	ADCP3048L3 X4/16	\$2219

Specifying

 **For Canadian Pricing**
 Multiply U.S. Price by the Canadian price factor.
 ▶ See page 1 for details.

X4/16 = Last order entry
 April 17, 2016

Radius Junction Tops ✕4/16

Tip: Junction tops are not designed to be converted to a freestanding desk.

Standard Includes	Required to Specify
<ul style="list-style-type: none"> ▶ Need help? Product details, page 24 • Worksurface: laminate • Worksurface ends: plastic default • Back edge: plastic T-mold default on laminate • Power beam, if selected: paint price group 1 • Modesty panel, if selected: paint price group 1 • Attachment brackets: black paint only 	<ul style="list-style-type: none"> 1 Style number 2 Color number for worksurface 3 Paint color number for power beam or modesty panel, if selected 4 Options, if selected (see below) ▶ See <i>Surface Materials</i>, page 130.

Options	U.S. Price	Required to Specify
Surface Materials <ul style="list-style-type: none"> • Desks with modesty panel • Paint price group 1 • Paint price group 2 • Paint price group 3 • Open Line laminate 	<ul style="list-style-type: none"> No cost +\$29 +\$48 +\$67 plus cost of laminate 	<ul style="list-style-type: none"> Specify paint color number. Specify paint color number. Specify paint color number. ▶ See <i>Surface Materials Reference Manual</i>.
Related Products <ul style="list-style-type: none"> • Desks • Accessories • Internode power and communication components 		<ul style="list-style-type: none"> ▶ Pages 52–61 ▶ Page 70 ▶ Page 108

Specification Information				
• Dimensions	• With Power Beam	• Style Number	• U.S. Base Price	
D	W			

90° Radius Junction Tops without Modesty Panel



30"/30"	36"	No	AJRS3090L3 ✕4/16	\$ 827
30"/30"	36"	Yes	AJRP3090L4 ✕4/16	\$ 910

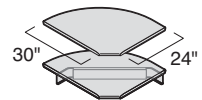

30"/24"	30"	No	AJRS3290L5 ✕4/16	\$ 827
30"/24"	30"	Yes	AJRP3290L6 ✕4/16	\$ 910



24"/30"	30"	No	AJRS2390L9 ✕4/16	\$ 827
24"/30"	30"	Yes	AJRP2390L0 ✕4/16	\$ 910

90° Radius Junction Tops with Modesty Panel



30"/30"	36"	Yes	AJRM3090L5 ✕4/16	\$1026
---------	-----	-----	--	--------



30"/24"	30"	Yes	AJRM3290L7 ✕4/16	\$1026
---------	-----	-----	--	--------

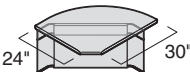

24"/30"	30"	Yes	AJRM2390L1 ✕4/16	\$1026
---------	-----	-----	--	--------



For Canadian Pricing
 Multiply U.S. Price by the Canadian price factor.
 ▶ See page 1 for details.

✕4/16 = Last order entry
 April 17, 2016

Tip: Junction tops are not designed to be converted to a freestanding desk.

Standard Includes		Required to Specify
<ul style="list-style-type: none"> ▶ Need help? Product details, page 24 	<ul style="list-style-type: none"> • Worksurface: laminate • Worksurface ends: plastic default • Back edge: laminate self-edge on laminate 90° triangular and plastic T-mold default on laminate H-tops • Power beam, if selected: paint price group 1 • Modesty panel, if selected: paint price group 1 • Attachment brackets: black paint only 	<ol style="list-style-type: none"> 1 Style number 2 Color number for worksurface 3 Paint color number for power beam or modesty panel, if selected 4 Options, if selected (see below) <ul style="list-style-type: none"> ▶ See <i>Surface Materials</i>, page 130.

Options	U.S. Price	Required to Specify
Surface Materials <ul style="list-style-type: none"> • Desks with modesty panel • Paint price group 1 • Paint price group 2 • Paint price group 3 • Open Line laminate 	<ul style="list-style-type: none"> No cost +\$29 +\$48 +\$67 plus cost of laminate 	<ul style="list-style-type: none"> Specify paint color number. Specify paint color number. Specify paint color number. ▶ See <i>Surface Materials Reference Manual</i>.

Related Products	<ul style="list-style-type: none"> • Desks • Accessories • Internode power and communication components 	<ul style="list-style-type: none"> ▶ Pages 52–61 ▶ Page 70 ▶ Page 108
-------------------------	--	--

Specification Information

• Dimensions	• With Power Beam	• Style Number	• U.S. Base Price
D W			

90° Triangular Junction Tops without Modesty Panel

30"/30"	36"	No	AJTS3090L5 X4/16	\$ 620
30"/30"	36"	Yes	AJTP3090L6 X4/16	\$ 703

90° "H" Triangular Junction Tops without Modesty Panel

30"/30"	48"	No	AJHS3090L0 X4/16	\$1179
30"/30"	48"	Yes	AJHP3090L1 X4/16	\$1279

90° "H" Triangular Junction Tops with Modesty Panel

30"/30"	48"	Yes	AJHM3090L2 X4/16	\$1413

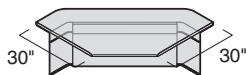
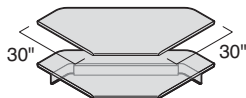
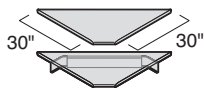

For Canadian Pricing
 Multiply U.S. Price by the Canadian price factor.
 ▶ See page 1 for details.

X4/16 = Last order entry
 April 17, 2016

Left-Hand Corner Conference Tables X4/16

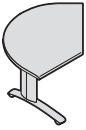

Standard Includes		Required to Specify
<ul style="list-style-type: none"> ▶ Need help? Product details, page 26 	<ul style="list-style-type: none"> • Corner conference leg: paint price group 1 • Power beam: paint price group 1 • Modesty panel, if selected: paint price group 1 • Worksurface: laminate • Worksurface ends: plastic default • Back edge: plastic T-mold default on laminate • Leg trim strip and glide cover: plastic • Attachment brackets: black paint only 	<ol style="list-style-type: none"> 1 Style number 2 Paint color number for legs, power beam, and modesty panel, if selected 3 Color number for worksurface 4 Plastic color number for leg trim strip and glide cover 5 Options, if selected (see below) <p>▶ See <i>Surface Materials</i>, page 130.</p>

Options	U.S. Price	Required to Specify
Surface Materials <ul style="list-style-type: none"> • Desks without modesty panel • Paint price group 1 • Paint price group 2 • Paint price group 3 • Open Line laminate 	<ul style="list-style-type: none"> No cost +\$19 +\$33 +\$67 plus cost of laminate	Specify paint color number. Specify paint color number. Specify paint color number. ▶ See <i>Surface Materials Reference Manual</i> .
<ul style="list-style-type: none"> • Desks with modesty panel • Paint price group 1 • Paint price group 2 • Paint price group 3 • Open Line laminate 	<ul style="list-style-type: none"> No cost +\$47 +\$81 +\$67 plus cost of laminate	Specify paint color number. Specify paint color number. Specify paint color number. ▶ See <i>Surface Materials Reference Manual</i> .

Related Products • Desks ▶ Pages 52–61

Specification Information				
Dimensions			Style Number	U.S. Base Price
D	W	H		

Left-Hand Corner Conference Tables without Modesty Panel

30"	36"	28½"	ATCL3036L1 X4/16	\$1613
-----	-----	------	-------------------------	--------

Left-Hand Corner Conference Tables with Modesty Panel

30"	36"	28½"	ATML3036L5 X4/16	\$1713
-----	-----	------	-------------------------	--------

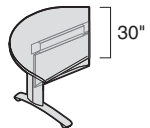
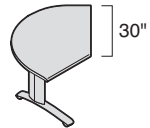

For Canadian Pricing
 Multiply U.S. Price by the Canadian price factor.
 ▶ See page 1 for details.

X4/16 = Last order entry
 April 17, 2016

Right-Hand Corner Conference Tables ✕4/16

Right-Hand Corner
Conference Tables

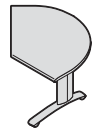

Standard Includes		Required to Specify
<ul style="list-style-type: none"> ▶ Need help? Product details, page 26 	<ul style="list-style-type: none"> • Corner conference leg: paint price group 1 • Power beam: paint price group 1 • Modesty panel, if selected: paint price group 1 • Worksurface: laminate • Worksurface ends: plastic default • Back edge: plastic T-mold default on laminate • Leg trim strip and glide cover: plastic • Attachment brackets: black paint only 	<ol style="list-style-type: none"> 1 Style number 2 Paint color number for legs, power beam, and modesty panel, if selected 3 Color number for worksurface 4 Plastic color number for leg trim strip and glide cover 5 Options, if selected (see below) <p>▶ See <i>Surface Materials</i>, page 130.</p>

Options	U.S. Price	Required to Specify
Surface Materials		
Desks without modesty panel		
• Paint price group 1	No cost	Specify paint color number.
• Paint price group 2	+\$19	Specify paint color number.
• Paint price group 3	+\$33	Specify paint color number.
• Open Line laminate	+\$67 plus cost of laminate	▶ See <i>Surface Materials Reference Manual</i> .
Desks with modesty panel		
• Paint price group 1	No cost	Specify paint color number.
• Paint price group 2	+\$47	Specify paint color number.
• Paint price group 3	+\$81	Specify paint color number.
• Open Line laminate	+\$67 plus cost of laminate	▶ See <i>Surface Materials Reference Manual</i> .

Related Products • Desks ▶ Pages 52–61

Specification Information

Dimensions			Style	U.S.
D	W	H	Number	Base Price

Right-Hand Corner Conference Tables without Modesty Panel

30"	36"	28½"	ATCR3036L9 ✕4/16	\$1613

Right-Hand Corner Conference Tables with Modesty Panel

30"	36"	28½"	ATMR3036L3 ✕4/16	\$1713

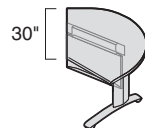
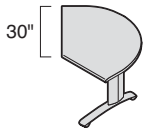

 **For Canadian Pricing**
Multiply U.S. Price by the
Canadian price factor.
▶ See page 1 for details.

✕4/16 = Last order entry
April 17, 2016

Round and Rectangular Conference Tables ✕4/16

Standard Includes	Required to Specify
<ul style="list-style-type: none"> ▶ Need help? Product details, page 26 • Column and base on round conference tables: paint price group 1, 2, or 3 • T-legs on rectangular conference tables: paint price group 1, 2, or 3 • Worksurface: laminate • Worksurface ends: plastic default • Leg trim strips and glide covers: plastic 	<ol style="list-style-type: none"> 1 Style number 2 Paint color number for column and base or legs 3 Color number for worksurface 4 Plastic color number for leg trim strips and glide covers 5 Options, if selected (see below) <p>▶ See <i>Surface Materials</i>, page 130.</p>

Options	U.S. Price	Required to Specify
Surface Materials <ul style="list-style-type: none"> • Rectangular Conference Tables • Paint price group 1 • Paint price group 2 • Paint price group 3 • Open Line laminate 	<ul style="list-style-type: none"> No cost +\$47 +\$81 +\$67 plus cost of laminate 	<ul style="list-style-type: none"> Specify paint color number. Specify paint color number. Specify paint color number. <p>▶ See <i>Surface Materials Reference Manual</i>.</p>

Specification Information				
• Dimensions			• Style	• U.S.
D	W	H	Number	Base Price



Round Conference Tables

42" diameter	28½"	ATGX0042L5 ✕4/16	\$1058

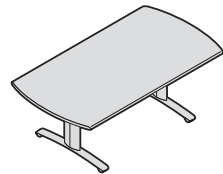

Rectangular Conference Tables

42"	78"	28½"	ATLX4278L1 ✕4/16	\$2218



For Canadian Pricing
 Multiply U.S. Price by the Canadian price factor.
 ▶ See page 1 for details.

✕4/16 = Last order entry
 April 17, 2016



Standard Includes		Required to Specify
▶ Need help? Product details, page 30	• Two supports: textured paint	1 Style number 2 Textured paint color number for supports ▶ See <i>Surface Materials</i> , page 130.

Specification Information				
• Dimensions			• Style	• U.S.
D	W	H	Number	Price
11"	1"	10"	AABX0000X2 X4/16	\$188

Specifying



For Canadian Pricing
Multiply U.S. Price by the
Canadian price factor.
▶ See page 1 for details.

X4/16 = Last order entry
April 17, 2016

Screens X4/16

Tip: Screens, if specified, for use with overhead cabinets, must be one size smaller in width than the worksurface. Example: Order 48"W for 54"W worksurface, 54"W for 60"W worksurface, etc.

Standard Includes		Required to Specify	
▶ Need help? Product details, page 30	<ul style="list-style-type: none"> • Screen with two tackable surfaces: vertical surface fabric price group 1 • Top trim strip: grotto plastic only 	1 Style number	2 Fabric color number for screen
		3 Options, if selected (see below)	▶ See <i>Surface Materials</i> , page 130.

Options	U.S. Price	Required to Specify
Surface Materials	<ul style="list-style-type: none"> • Fabric price group 1 No cost • Fabric price group 2 +\$ 12 • Fabric price group 3 +\$ 54 • Fabric price group 4 +\$ 73 • Fabric price group 5 +\$117 • Fabric price group COM +\$ 16 	Specify fabric color number. Specify fabric color number. Specify fabric color number. Specify fabric color number. Specify fabric color number. ▶ See <i>Surface Materials Reference Manual</i> .
Related Products	<ul style="list-style-type: none"> • Supports • Transaction tops • Desks • Desks with overhead cabinet • Returns 	▶ Page 67 ▶ Page 69 ▶ Pages 52–57 ▶ Page 58 ▶ Page 60

Specification Information

Dimensions	Style Number	U.S. Base Price
W H		

12"H Screens

30"	12"	AATX3012X5 X4/16	\$347
36"	12"	AATX3612X1 X4/16	\$370
42"	12"	AATX4212X4 X4/16	\$398
48"	12"	AATX4812X0 X4/16	\$425
54"	12"	AATX5412X3 X4/16	\$452
60"	12"	AATX6012X6 X4/16	\$477
66"	12"	AATX6612X2 X4/16	\$483
72"	12"	AATX7212X2 X4/16	\$527

22"H Screens

30"	22"	AATX3022X6 X4/16	\$484
36"	22"	AATX3622X2 X4/16	\$513
42"	22"	AATX4222X5 X4/16	\$534
48"	22"	AATX4822X1 X4/16	\$561
54"	22"	AATX5422X4 X4/16	\$587
60"	22"	AATX6022X7 X4/16	\$613
66"	22"	AATX6622X3 X4/16	\$641
72"	22"	AATX7222X3 X4/16	\$661

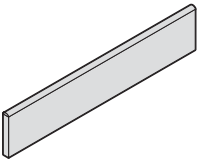

Tip: 12"H screens are for use with transaction tops.

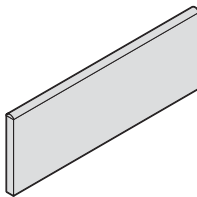

For Canadian Pricing
 Multiply U.S. Price by the Canadian price factor.
 ▶ See page 1 for details.

X4/16 = Last order entry
 April 17, 2016

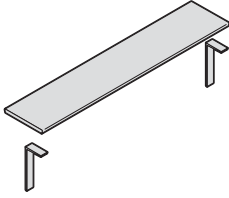

Tip: Transaction tops can only be used with 12"H screens.

Tip: Supports, ordered separately, are necessary to install transaction tops.

▶ Page 67

Tip: Specify a textured paint color for attachment brackets to match the color of the supports and grommet default.

▶ Page 130

Standard Includes		Required to Specify
-------------------	--	---------------------

- | | | |
|---|--|--|
| <ul style="list-style-type: none"> ▶ Need help? Product details, page 30 | <ul style="list-style-type: none"> • Top: laminate • Attachment brackets: textured paint | <ol style="list-style-type: none"> 1 Style number 2 Textured paint color number for attachment brackets (specify color to match supports that are ordered separately) 3 Color number for top 4 Options, if selected (see below) <p>▶ See <i>Surface Materials</i>, page 130.</p> |
|---|--|--|

Options	U.S. Price	Required to Specify
---------	------------	---------------------

- | | | |
|---|--------------------------------|---|
| Surface Materials <ul style="list-style-type: none"> • Open Line laminate | +\$67
plus cost of laminate | ▶ See <i>Surface Materials Reference Manual</i> . |
| Related Products <ul style="list-style-type: none"> • Supports • Screens | | ▶ Page 67
▶ Page 68 |

Specification Information				
Dimensions			Style	U.S.
D	W	H	Number	Base Price

12"	30"	1"	AASX1230L8 X4/16	\$273
12"	36"	1"	AASX1236L9 X4/16	\$292
12"	42"	1"	AASX1242L0 X4/16	\$312
12"	48"	1"	AASX1248L1 X4/16	\$330
12"	54"	1"	AASX1254L2 X4/16	\$352
12"	60"	1"	AASX1260L1 X4/16	\$370
12"	66"	1"	AASX1266L3 X4/16	\$394
12"	72"	1"	AASX1272L0 X4/16	\$415
:	:	:	:	:

Specifying

For Canadian Pricing
Multiply U.S. Price by the Canadian price factor.
▶ See page 1 for details.

X4/16 = Last order entry
April 17, 2016

Accessories

Dividers

For Use with Overhead Storage Bins and Universal Shelves Introduced in March 2007



Standard Includes	Required to Specify
<ul style="list-style-type: none"> ▶ Need help? Product details, page 20 • Package of four dividers: white plastic only 	Style number

Specification Information	
New Style Number	U.S. Price
RDIV	\$44

Plastic Center Drawer

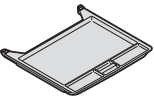

Standard Includes	Required to Specify
<ul style="list-style-type: none"> ▶ Need help? Product details, page 18 • Drawer: black textured plastic only • Slides: black plastic only • Attachment hardware and template 	Style number

Specification Information				
Dimensions			Style Number	U.S. Price
D	W	H		
19"	21"	13/8"	ASHC1921X1	\$83

Return Filler X4/16

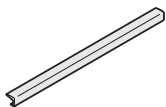

Standard Includes	Required to Specify
<ul style="list-style-type: none"> ▶ Need help? Product details, page 19 • Return filler: plastic 	1 Style number 2 Plastic color number for filler ▶ See <i>Surface Materials</i> , page 130.

Specification Information			
Length	Style Number		U.S. Price
24"	ARFS0024X1	X4/16	\$44
30"	ARFS0030X1	X4/16	\$45
36"	ARFS0036X1	X4/16	\$48



For Canadian Pricing
 Multiply U.S. Price by the Canadian price factor.
 ▶ See page 1 for details.

X4/16 = Last order entry
 April 17, 2016

Power Beam Receptacle **X4/16**

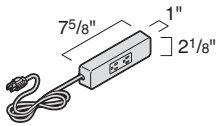

Tip: Clips onto power beam.

Tip: Not for use in New York City.

Standard Includes	Required to Specify
-------------------	---------------------

- | | |
|---|---|
| <ul style="list-style-type: none"> ▶ Need help? Product details, page 20 | <ul style="list-style-type: none"> • Receptacle with 8' cord and three-prong plug • 9 amps, 125 volts • Two outlets: black plastic |
|---|---|

Style number

Specification Information

• Style Number	• U.S. Price
AAES0000X1 X4/16	\$158

Specifying



For Canadian Pricing

Multiply U.S. Price by the Canadian price factor.

▶ See page 1 for details.

X4/16 = Last order entry
April 17, 2016

Universal Fixed Pedestals

With Proud Steel or Wood Front



Standard Includes		Required to Specify
<ul style="list-style-type: none"> ▶ Need help? See <i>Storage Specification Guide</i>. 	<ul style="list-style-type: none"> • Pedestal: paint price group 1 • Removable drawer fronts: paint to match pedestal or wood veneer if proud wood front selected • Pulls: metal • Full drawer interiors: black only <ul style="list-style-type: none"> – One pencil tray and two box drawer dividers per box/box/file and box drawer dividers • Lock, keyed random: 9201 Polished Chrome • Mounting hardware • Four adjustable leveling glides 	<ol style="list-style-type: none"> 1 Style number with appropriate front style suffix in the space provided <ul style="list-style-type: none"> P Proud steel front W Proud wood front 2 Paint color number for pedestal 3 Wood color number for drawer fronts, if proud wood front selected 4 Pull (see below under required selections) 5 Metal color number for pulls, if proud steel or proud wood front selected 6 Options, if selected (see below) <ul style="list-style-type: none"> ▶ See <i>Surface Materials</i>, page 130.

Required Selections

Pulls

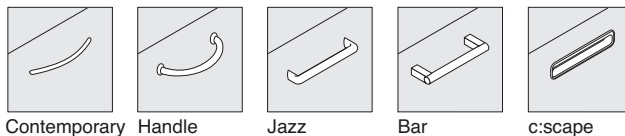

	Options	U.S. Price	Required to Specify
Surface Materials	<ul style="list-style-type: none"> • Paint price group 1 • Paint price group 2 • Paint price group 3 • Premium wood 2 on proud wood drawer fronts • Premium wood 3 on proud wood drawer fronts • Customiz stain on proud wood drawer fronts 	<ul style="list-style-type: none"> No cost +\$ 43 +\$ 73 See information at left See information at left No cost 	<ul style="list-style-type: none"> Specify paint color number. Specify paint color number. Specify paint color number. Specify Premium wood 2 finish number. Specify Premium wood 3 finish number. Specify with <i>Customiz stain</i>. ▶ See <i>Surface Materials Reference Manual</i>.
Pulls	<p>Proud steel or wood fronts</p> <ul style="list-style-type: none"> • Contemporary • Handle • Jazz • Bar <p>Proud steel fronts only</p> <ul style="list-style-type: none"> • c:scape 	<ul style="list-style-type: none"> No cost No cost +\$ 17 per pull +\$ 25 per pull +\$ 29 per pull 	<ul style="list-style-type: none"> Specify with <i>contemporary pull</i>. Specify with <i>handle pull</i>. Specify with <i>jazz pull</i>. Specify with <i>bar pull</i>. Specify with <i>c:scape pull</i>.
Drawer Accessories	<p>Rails</p> <ul style="list-style-type: none"> • Two side-to-side hanging rails per file drawer 	<ul style="list-style-type: none"> No cost 	<ul style="list-style-type: none"> Specify with <i>rails</i>.
Basic Drawer Interiors	<p>18"D box/box/file pedestals</p> <ul style="list-style-type: none"> • No rails, pencil trays, or box drawer dividers 	<ul style="list-style-type: none"> -\$ 50 	<ul style="list-style-type: none"> Specify with <i>basic drawers</i>.
Lock and Keying	<p>Lock</p> <ul style="list-style-type: none"> • Ember Chrome • No lock <p>Individual locking drawers</p> <ul style="list-style-type: none"> • File/file pedestals only <p>Keying</p> <ul style="list-style-type: none"> • Factory- and field-installed keying 	<ul style="list-style-type: none"> No cost -\$ 61 +\$122 	<ul style="list-style-type: none"> Specify with <i>9250 Ember Chrome lock</i>. Specify with <i>no lock</i>. Specify with <i>individual drawer lock</i>. ▶ Page 142

Related Products	<ul style="list-style-type: none"> • Universal fixed to freestanding pedestal conversion kits • Storage accessories 	<ul style="list-style-type: none"> ▶ Page 74 ▶ Page 101
-------------------------	---	---

Premium Wood Pricing: For Premium wood 2 or Premium wood 3 pricing, please refer to the electronic catalog or SmartTools.

 **For Canadian Pricing**
Multiply U.S. Price by the Canadian price factor.
▶ See page 1 for details.

Tip: Your specification is not complete until you add a suffix to the style number to define the front style (for example, RPF1827A__ becomes RPF1827AP for proud steel front).



Tip: Specify 18³/₈"D pedestals under 24"D, 30"D, and 36"D Ellipse desks.

Tip: 18³/₈"D pedestals do not accommodate legal-size side-to-side filing.



Tip: 25¹/₂"H fixed pedestals are for use in the following two applications: as fixed pedestals when used underneath worksurfaces installed at lower than standard heights (for example, 27"H) or as freestanding pedestals when used with a conversion kit under height-adjustable worksurfaces.

Specification Information

Dimensions			Style Number	U.S. Base Prices	
D	W	H		Proud Steel Front	Proud Wood Front
				Suffix P	Suffix W

27"H Fixed Pedestals with 3" Base

Two Box Drawers and One File Drawer

18 ³ / ₈ "	15"	27"	RPF1827A__	\$617	\$860
----------------------------------	-----	-----	-------------------	-------	-------

Two File Drawers

18 ³ / ₈ "	15"	27"	RPF1827B__	\$600	\$843
----------------------------------	-----	-----	-------------------	-------	-------

25¹/₂"H Fixed Pedestals

Two Box Drawers and One File Drawer

18 ³ / ₈ "	15"	25 ¹ / ₂ "	RPF1825A__	\$617	\$860
----------------------------------	-----	----------------------------------	-------------------	-------	-------

Two File Drawers

18 ³ / ₈ "	15"	25 ¹ / ₂ "	RPF1825B__	\$600	\$843
----------------------------------	-----	----------------------------------	-------------------	-------	-------

 **For Canadian Pricing**
 Multiply U.S. Price by the Canadian price factor.
 ▶ See page 1 for details.

Universal Fixed to Freestanding Pedestal Conversion Kits

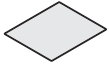

Tip: When converting a file/file pedestal with individual drawer locks, an interlocking bar is required to provide stability to unit.
 Order Service Part Number 1043924SR.

Standard Includes		Required to Specify
▶ Need help? See <i>Storage Specification Guide</i> .	<ul style="list-style-type: none"> • 1/8"H steel top: all paint price groups • Counterweight package • Safety interlock system conversion components • Installation hardware 	1 Style number 2 Paint color number for top ▶ See <i>Surface Materials</i> , page 130.

Specification Information

Dimensions		Style	U.S.
D	H	Number	Price

For 27"H Proud Steel or Proud Wood Front Pedestals

18 ³ / ₈ "	27"	RPXCK2718P	\$188
23 ¹ / ₂ "	27"	RPXCK2724P	\$208
29 ¹ / ₂ "	27"	RPXCK2730P	\$229
:	:	:	:

For 25¹/₂"H Proud Steel or Proud Wood Front Pedestals

18 ³ / ₈ "	25 ¹ / ₂ "	RPXCK2518P	\$188
23 ¹ / ₂ "	25 ¹ / ₂ "	RPXCK2524P	\$208
29 ¹ / ₂ "	25 ¹ / ₂ "	RPXCK2530P	\$229
:	:	:	:



For Canadian Pricing
 Multiply U.S. Price by the Canadian price factor.
 ▶ See page 1 for details.

Universal Mobile Pedestals

With Proud Steel or Wood Front



Tip: 1/8"H steel top is non-structural.

Standard Includes		Required to Specify
<ul style="list-style-type: none"> ▶ Need help? See <i>Storage Specification Guide</i>. 	<ul style="list-style-type: none"> • Pedestal: paint price group 1 • 1/8"H steel top: paint to match pedestal • Removable drawer fronts: paint to match pedestal or wood veneer if proud wood front selected • Pulls: metal • Full drawer interiors: black only <ul style="list-style-type: none"> – One pencil tray per box/file or box/box/file and box drawer dividers • Lock, keyed random: 9201 Polished Chrome • Four hard-composition, non-locking casters: black only • Safety interlock mechanism • Counterweight package 	<ol style="list-style-type: none"> 1 Style number with appropriate front style suffix in the space provided <ul style="list-style-type: none"> P Proud steel front W Proud wood front 2 Paint color number for pedestal 3 Wood color number for drawer fronts, if proud wood front selected 4 Pull (see below under required selections) 5 Metal color number for pulls, if proud steel or proud wood front selected 6 Options, if selected (see below) <ul style="list-style-type: none"> ▶ See <i>Surface Materials</i>, page 130.

Required Selections

Pulls

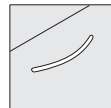

Contemporary

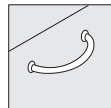

Handle

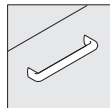

Jazz

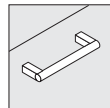

Bar

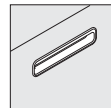

c:scape

Options	U.S. Price	Required to Specify
Surface Materials <ul style="list-style-type: none"> • Paint price group 1 • Paint price group 2 • Paint price group 3 • Premium wood 2 on proud wood drawer fronts • Premium wood 3 on proud wood drawer fronts • Customiz stain on proud wood drawer fronts 	<ul style="list-style-type: none"> No cost +\$ 43 +\$ 73 See information at left See information at left No cost 	<ul style="list-style-type: none"> Specify paint color number. Specify paint color number. Specify paint color number. Specify Premium wood 2 finish number. Specify Premium wood 3 finish number. Specify <i>with Customiz stain</i>. ▶ See <i>Surface Materials Reference Manual</i>.
Tops <ul style="list-style-type: none"> • 1"H square edge steel top 	<ul style="list-style-type: none"> +\$ 64 	<ul style="list-style-type: none"> Specify <i>with steel square top</i>.
Laminate top <ul style="list-style-type: none"> • 1 3/16"H square edge laminate top • 1 7/16"H bullnose laminate top • Open Line laminate on laminate top 	<ul style="list-style-type: none"> +\$275 +\$313 +\$ 67 plus cost of laminate 	<ul style="list-style-type: none"> Specify <i>with laminate top</i> and indicate laminate color number for top and plastic color number for edges. Specify <i>with bullnose laminate top</i> and indicate laminate color number. ▶ See <i>Surface Materials Reference Manual</i>.
Wood veneer top <ul style="list-style-type: none"> • 1 3/16"H wood veneer top • Premium wood 2 • Premium wood 3 • Customiz stain on wood veneer top 	<ul style="list-style-type: none"> +\$383 See information at left See information at left No cost 	<ul style="list-style-type: none"> Specify <i>with wood veneer top</i> and indicate wood color number. Specify <i>with wood veneer top</i> and indicate Premium wood 2 finish number. Specify <i>with wood veneer top</i> and indicate Premium wood 3 finish number. Specify <i>with Customiz stain</i>. ▶ See <i>Surface Materials Reference Manual</i>.
Cushion top for factory installation on RPM2421C__ only <ul style="list-style-type: none"> • Cushion top without handle • Cushion top with black handle 	<ul style="list-style-type: none"> +\$337 +\$429 	<ul style="list-style-type: none"> Specify <i>with cushion top</i> and indicate fabric color number. Specify <i>with cushion top and handle</i> and indicate fabric color number.

Premium Wood

Pricing: For Premium wood 2 or Premium wood 3 pricing, please refer to the electronic catalog or SmartTools.

Tip: Optional tops will increase the overall pedestal height.

Tip: If wood veneer top option is selected, finishes must be selected for both the wood veneer top and the wood veneer fronts.

▶ Options, continued on next page

 **For Canadian Pricing**
Multiply U.S. Price by the Canadian price factor.
▶ See page 1 for details.

► Options, continued from previous page

Options	U.S. Price	Required to Specify
Tops, cont	Upholstery on pedestal cushion top	
• Fabric price group 1	No cost	Specify fabric color number.
• Fabric price group 2	+\$ 10	Specify fabric color number.
• Fabric price group 3	+\$ 39	Specify fabric color number.
• Fabric price group 4	+\$ 48	Specify fabric color number.
• Fabric price group 5	+\$ 60	Specify fabric color number.
• Fabric price group 6	+\$ 85	Specify fabric color number.
• Fabric price group 7	+\$103	Specify fabric color number.
• Fabric price group 8	+\$149	Specify fabric color number.
• Fabric price group 9	+\$191	Specify fabric color number.
• Fabric price group 10	+\$232	Specify fabric color number.
• Leather price group	+\$595	Specify leather color number.
• Elmosoft leather price group	+\$688	Specify Elmosoft leather color number.
• Customer's Own Material (COM) or Customer's Own Leather (COL)	+\$ 16	► See <i>Surface Materials</i> , page 130. ► See <i>Surface Materials Reference Manual</i> to specify.
Pulls	Proud steel or wood fronts	
• Contemporary	No cost	Specify with <i>contemporary pull</i> .
• Handle	No cost	Specify with <i>handle pull</i> .
• Jazz	+\$ 17 per pull	Specify with <i>jazz pull</i> .
• Bar	+\$ 25 per pull	Specify with <i>bar pull</i> .
	Proud steel fronts only	
• c:scape	+\$ 29 per pull	Specify with <i>c:scape pull</i> .
Drawer Accessories	Rails	
• Two side-to-side hanging rails per file drawer	No cost	Specify with <i>rails</i> .
Basic Drawer Interiors	Box/file and box/box/file pedestals	
• No rails, pencil trays, or box drawer dividers	-\$ 50	Specify with <i>basic drawers</i> .
Lock and Keying	Lock	
• Ember Chrome	No cost	Specify with <i>9250 Ember Chrome lock</i> .
	Individual locking drawers	
• File/file pedestals only	+\$122	Specify with <i>individual drawer lock</i> .
	Keying	
• Factory- and field-installed keying		► Page 142
Related Products	• Storage accessories	► Page 101

Specifying

► Specification Information, on next page



For Canadian Pricing
 Multiply U.S. Price by the Canadian price factor.
 ► See page 1 for details.

Universal Mobile Pedestals with Proud Steel or Proud Wood Fronts, continued

Tip: Your specification is not complete until you add a suffix to the style number to define the front style (for example, RPM1821C__ becomes RPM1821CP for proud steel front).



► Options, on previous page

Specification Information

Actual Dimensions D W H	Style Number	U.S. Base Prices	
		Proud Steel Front Suffix P	Proud Wood Front Suffix W

Box/File

18 ³ / ₈ " 15" 21"	RPM1821C__	\$848	\$1091
23 ¹ / ₂ " 15" 21"	RPM2421C__	\$892	\$1135

Box/Box/File

18 ³ / ₈ " 15" 27"	RPM1827A__	\$906	\$1150
23 ¹ / ₂ " 15" 27"	RPM2427A__	\$962	\$1206

File/File

18 ³ / ₈ " 15" 27"	RPM1827B__	\$890	\$1134
23 ¹ / ₂ " 15" 27"	RPM2427B__	\$946	\$1190

Specification Information

Actual Dimensions D W H	Style Number	U.S.
		Base Price

Pedestal Cushion Top for Field Installation on RPM2421C__ only

Cushion Top without Handle

23 ¹ / ₂ " 15" 2 ¹ / ₄ "	RPXTC24P	\$297
--	-----------------	-------

Cushion Top with Black Handle

23 ¹ / ₂ " 15" 2 ¹ / ₄ "	RPXTCH24P	\$400
--	------------------	-------



For Canadian Pricing

Multiply U.S. Price by the Canadian price factor.

► See page 1 for details.

Universal Lateral Files

With Flush Steel, Proud Steel, or Proud Wood Front

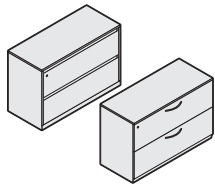

Standard Includes		Required to Specify
<ul style="list-style-type: none"> ▶ Need help? See <i>Storage Specification Guide</i>. 	<ul style="list-style-type: none"> Lateral file: paint price group 1 1"H top on units with flush steel or proud steel fronts: paint to match file 1³/₁₆"H top and drawer fronts on units with proud wood fronts: wood veneer Integral pulls on units with flush steel front Pulls: metal Lift-up door with fixed shelf on 65¹/₂"H units with flush steel or proud steel front: paint to match file Lift-up door with fixed shelf on 65¹/₂"H units with proud wood fronts: wood veneer to match file Central lock, keyed random: 9201 Polished Chrome One label holder per drawer: clear plastic Drawer body: black only Drawer suspensions: black only One hanging folder bar per drawer on 18"D units Two rails per drawer on 24"D units One hanging folder bar and three dividers on roll-out shelf, if selected Four adjustable leveling glides Counterweight package, if selected 	<ol style="list-style-type: none"> Style number with appropriate front style suffix in the space provided <ul style="list-style-type: none"> F Flush steel front P Proud steel front W Proud wood front Paint color number for file Wood color number for drawer fronts and top, if proud wood front selected Pull (see below under required selections) Metal color number for pulls, if proud steel or proud wood front selected Options, if selected (see below) <ul style="list-style-type: none"> ▶ See <i>Surface Materials</i>, page 130.

Required Selections

Pulls

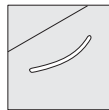

Contemporary

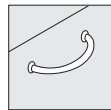

Handle

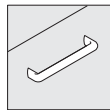

Jazz

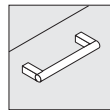

Bar

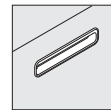

c:scape

	Options	U.S. Price	Required to Specify
Surface Materials	<ul style="list-style-type: none"> Paint price group 1 Paint price group 2 Paint price group 3 	No cost +\$ 73 +\$125	Specify paint color number. Specify paint color number. Specify paint color number.
	Premium wood on proud wood fronts and top <ul style="list-style-type: none"> Premium wood 2 Premium wood 3 	See information at left See information at left	Specify Premium wood 2 finish number. Specify Premium wood 3 finish number.
Tops with Flush Steel Front and Proud Steel Front	Customiz stain on proud wood fronts and top <ul style="list-style-type: none"> 28"H or 40"H files 52"H or 65¹/₂"H files 	No cost No cost	Specify with <i>Customiz stain</i> . Specify with <i>Customiz stain</i> . ▶ See <i>Surface Materials Reference Manual</i> .
	Security top <ul style="list-style-type: none"> For use on 28"H lateral files only 	No cost	Specify with <i>security top</i> .
	No top on 28"H, 40"H, or 52"H <ul style="list-style-type: none"> For use under a worksurface or beneath a common top 	-\$ 94	Specify with <i>no top</i> .
	Laminate top <ul style="list-style-type: none"> Square edge laminate top 	+\$130	Specify with <i>laminate top</i> and indicate laminate color number for top and plastic color number for edges.
	<ul style="list-style-type: none"> FrameOne laminate top Open Line laminate on laminate top 	+\$341 +\$ 67 plus cost of laminate	Specify with <i>FrameOne laminate top</i> and indicate laminate color number for top and plastic color number for edges. ▶ See <i>Surface Materials Reference Manual</i> .

▶ Options, continued on next page

Premium Wood Pricing: For Premium wood 2 or Premium wood 3 pricing, please refer to the electronic catalog or SmartTools.

Tip: Security top reduces overall height by approximately 1".

Tip: Laminate and wood veneer tops are ³/₁₆" taller than other tops and will add ³/₁₆" to overall case height.

Tip: FrameOne tops are available on 28"H lateral files only. FrameOne top will add ¹/₂" to the overall height.

► Options, continued from previous page

	Options	U.S. Price	Required to Specify	
Tops with Flush Steel Front and Proud Steel Front, continued	Wood veneer top			
	• Wood veneer top	+\$394	Specify with wood veneer top and indicate wood color number.	
	• FrameOne wood veneer top	+\$604	Specify with FrameOne wood veneer top and indicate wood color number.	
	• Premium wood 2	See information at left	Specify with wood veneer top and indicate Premium wood 2 finish number.	
Tops with Proud Wood Front	• Premium wood 3	See information at left	Specify with wood veneer top and indicate Premium wood 3 finish number.	
	• Customiz stain on wood veneer top	No cost	Specify with Customiz stain. ► See Surface Materials Reference Manual.	
	Security top			
	• For use on 28"H lateral files only	-\$394	Specify with security top.	
Tops with Proud Wood Front	No top on 28"H, 40"H, or 52"H			
	• For use under a worksurface or beneath a common top	-\$488	Specify with no top.	
	Laminate top			
	• Square edge laminate top	-\$264	Specify with laminate top and indicate laminate color number for top and plastic color number for edges.	
Tops with Proud Wood Front	• FrameOne laminate top	-\$ 53	Specify with FrameOne laminate top and indicate laminate color number for top and plastic color number for edges.	
	• Open Line laminate on laminate top	+\$ 67 plus cost of laminate	► See Surface Materials Reference Manual.	
	Wood top			
Tops with Proud Wood Front	• FrameOne wood veneer top	+\$210	Specify with FrameOne wood veneer top and indicate wood color number.	
	Drawer Interiors	• HF bar for use on 24"D units only	+\$ 12	Specify with HF bar.
		• Divider package	+\$ 25	Specify with divider package.
• Rails for use on 18"D units only		+\$ 32	Specify with rails.	
Lift-Up Door With Roll-Out Shelf	65 1/2"H flush steel front files only			
	• On 18"D files	+\$ 41	Specify with roll-out shelf.	
Lift-Up Door With Roll-Out Shelf	• On 24"D files	+\$ 58	Specify with roll-out shelf.	
	Pulls	Proud steel or wood fronts		
• Contemporary		No cost	Specify with contemporary pull.	
• Handle		No cost	Specify with handle pull.	
• Jazz		+\$ 17 per pull	Specify with jazz pull.	
Pulls	• Bar	+\$ 25 per pull	Specify with bar pull.	
	Proud steel fronts only			
Pulls	• c:scape	+\$ 29 per pull	Specify with c:scape pull.	
	Counterweights	• Package 1	+\$ 86	Specify with counterweight.
• Package 2		+\$ 96	Specify with counterweight.	
• Package 3		+\$109	Specify with counterweight.	
• Package 4		+\$142	Specify with counterweight.	
Lock and Keying	Lock			
	• Ember Chrome	No cost	Specify with 9250 Ember Chrome lock.	
Lock and Keying	Individual locking drawers on 18"D file			
	• With two drawers	+\$122	Specify with individual lock.	
	• With three drawers	+\$244	Specify with individual lock.	
	• With four drawers	+\$366	Specify with individual lock.	

► Options, continued on next page

Tip: Wood veneer tops are 3/16" taller than other tops and will add 3/16" to overall case height.

Tip: FrameOne tops are available on 28"H lateral files only. FrameOne top will add 1/2" to the overall height.

Premium Wood Pricing: For Premium wood 2 or Premium wood 3 pricing, please refer to the electronic catalog or SmartTools.

Tip: Full-fill finish (option) is available on field-installed tops only.
► Page 98

Tip: Security top reduces overall height by approximately 1".

Tip: Counterweight packages are recommended based on case size and interior options.
► See Specification Information on next page.

Tip: Counterweight option should be specified if the cabinet is not ganged to adjacent cabinets or bolted to the floor or wall.

Tip: Counterweight packages ship separately from case and must be installed on site.

Universal Lateral Files with Flush Steel, Proud Steel, or Proud Wood Front, continued

► **Options, continued from previous page**

Tip: 65½"H files with individual lock option do not have a lock in the lift-up door. Lift-up door is locked by the drawer below.

Tip: Height dimension listed is for units with 1" top. Overall height will vary if another top is selected.

Tip: Your specification is not complete until you add a suffix to the style number to define the front style (for example, RLF18362 becomes RLF18362F for flush steel front).

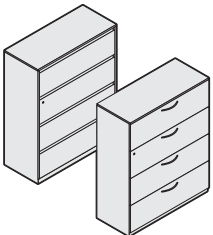
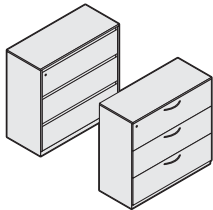
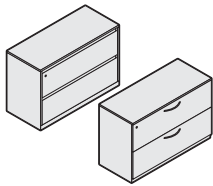

Options	U.S. Price	Required to Specify
Lock and Keying, continued	Individual locking drawers on 24"D file	
• With two drawers	+\$136	Specify with individual lock.
• With three drawers	+\$272	Specify with individual lock.
• With four drawers	+\$408	Specify with individual lock.
	Keying	
	• Factory- and field-installed keying	► Page 142
Related Products	• Storage accessories	► Page 101
	• Shelf bookends	► Page 104
	• Field-installed tops	► Pages 97–99
	• Counterweights	► Page 105

Specification Information

Dimensions				Recommended Counterweight Package	Style Number	U.S. Base Prices		
D	W	H	Flush Steel Front			Proud Steel Front	Proud Wood Front	
						Suffix F	Suffix P	Suffix W

Two 12"H Drawers

18"	18 ⁷ / ₈ "	30"	28"	Package 3	RLF18302 _	\$ 844	\$ 901	\$1793
18"	18 ⁷ / ₈ "	36"	28"	Package 4	RLF18362 _	\$ 985	\$1053	\$1921
18"	18 ⁷ / ₈ "	42"	28"	Package 4	RLF18422 _	\$1113	\$1193	\$2172
23 ¹ / ₈ "	24"	30"	28"	Package 3	RLF24302 _	\$1033	\$1105	\$2148
23 ¹ / ₈ "	24"	36"	28"	Package 4	RLF24362 _	\$1239	\$1325	\$2309

Three 12"H Drawers

18"	18 ⁷ / ₈ "	30"	40"	Package 3	RLF18303 _	\$1135	\$1270	\$2261
18"	18 ⁷ / ₈ "	36"	40"	Package 3	RLF18363 _	\$1319	\$1480	\$2436
18"	18 ⁷ / ₈ "	42"	40"	Package 3	RLF18423 _	\$1492	\$1673	\$2556
23 ¹ / ₈ "	24"	30"	40"	Package 2	RLF24303 _	\$1452	\$1628	\$2583
23 ¹ / ₈ "	24"	36"	40"	Package 2	RLF24363 _	\$1657	\$1857	\$2800

Four 12"H Drawers

18"	18 ⁷ / ₈ "	30"	52"	Package 3	RLF18304 _	\$1483	\$1662	\$2785
18"	18 ⁷ / ₈ "	36"	52"	Package 4	RLF18364 _	\$1725	\$1931	\$3023
18"	18 ⁷ / ₈ "	42"	52"	Package 4	RLF18424 _	\$1948	\$2184	\$3256
23 ¹ / ₈ "	24"	30"	52"	Package 2	RLF24304 _	\$1859	\$2085	\$3219
23 ¹ / ₈ "	24"	36"	52"	Package 3	RLF24364 _	\$2163	\$2427	\$3511

► **Specification Information, continued on next page**

 **For Canadian Pricing**
 Multiply U.S. Price by the Canadian price factor.
 ► See page 1 for details.

► **Specification Information, continued from previous page**

Specification Information

• Dimensions		W	H	• Recommended Counterweight Package	• Style Number	• U.S. Base Prices		
D						Flush Steel Front	Proud Steel/Wood Front	Proud Steel Front

Four 12"H Drawers and One 13¹/₂"H Lift-Up Door with Fixed Shelf

18"	18 ⁷ / ₈ "	30"	65 ¹ / ₂ "	Package 2	RLF18305 _	\$1779	\$1991	\$3154
18"	18 ⁷ / ₈ "	36"	65 ¹ / ₂ "	Package 2	RLF18365 _	\$2064	\$2315	\$3440
18"	18 ⁷ / ₈ "	42"	65 ¹ / ₂ "	Package 3	RLF18425 _	\$2333	\$2615	\$3724
23 ¹ / ₈ "	24"	30"	65 ¹ / ₂ "	Package 1	RLF24305 _	\$2231	\$2504	\$3677
23 ¹ / ₈ "	24"	36"	65 ¹ / ₂ "	Package 1	RLF24365 _	\$2591	\$2905	\$4033

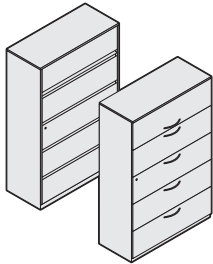

Specifying

 **For Canadian Pricing**
 Multiply U.S. Price by the Canadian price factor.
 ► See page 1 for details.

Universal Combination Cabinets

With Flush Steel, Proud Steel, or Proud Wood Front

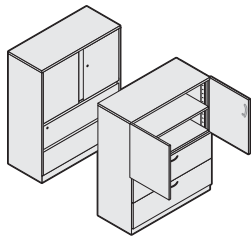

Standard Includes		Required to Specify
<p>▶ Need help? See <i>Storage Specification Guide</i>.</p> <ul style="list-style-type: none"> • Combination cabinet: paint price group 1 • 1"H top on units with flush steel or proud steel front: paint to match cabinet • 1³/₁₆"H top and drawer fronts on units with proud wood front: wood veneer • Integral pulls on units with flush steel front • Pulls: metal • Hinged doors on units with flush steel or proud steel front, if selected: paint to match • Hinged doors on units with proud wood fronts, if selected: wood veneer to match cabinet • Individual lock on door, keyed random: 9201 Polished Chrome • Central lock on drawers, keyed random: 9201 Polished Chrome • One label holder per drawer: clear plastic • Adjustable shelves: paint to match cabinet • Brackets for adjustable shelves: black • Drawer body: black only • Drawer suspensions: black only • One hanging folder bar per drawer on 18"D units • Two rails per drawer on 24"D units • Four adjustable leveling glides • Counterweight package, if selected 	<ol style="list-style-type: none"> 1 Style number with appropriate front style suffix in the space provided <ul style="list-style-type: none"> F Flush steel front P Proud steel front W Proud wood front 2 Paint color number for cabinet 3 Wood color number for drawer fronts, hinged door fronts, and top, if proud wood front selected 4 Pull (see below under required selections) 5 Metal color number for pulls, if proud steel or proud wood front selected 6 Options, if selected (see below) <p>▶ See <i>Surface Materials</i>, page 130.</p>	

Required Selections

Pulls



Contemporary



Handle

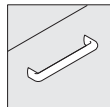

Jazz

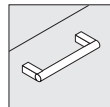

Bar

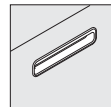

c:scape

Options	U.S. Price	Required to Specify
<p>Surface Materials</p> <p>52"H or 65¹/₂"H cabinets</p> <ul style="list-style-type: none"> • Paint price group 1 • Paint price group 2 • Paint price group 3 <hr/> <p>83¹/₂"H cabinets</p> <ul style="list-style-type: none"> • Paint price group 1 • Paint price group 2 • Paint price group 3 <hr/> <ul style="list-style-type: none"> • Premium wood 2 on proud wood fronts and top • Premium wood 3 on proud wood fronts and top • Customiz stain on proud wood fronts and top 	<p>No cost</p> <p>+\$ 73</p> <p>+\$125</p> <hr/> <p>No cost</p> <p>+\$110</p> <p>+\$186</p> <hr/> <p>See information at left</p> <p>See information at left</p> <p>No cost</p>	<p>Specify paint color number.</p> <p>Specify paint color number.</p> <p>Specify paint color number.</p> <hr/> <p>Specify paint color number.</p> <p>Specify paint color number.</p> <p>Specify paint color number.</p> <hr/> <p>Specify Premium wood 2 finish number.</p> <p>Specify Premium wood 3 finish number.</p> <p>Specify with <i>Customiz stain</i>.</p> <p>▶ See <i>Surface Materials Reference Manual</i>.</p>
<p>Tops with Flush Steel Front and Proud Steel Front</p> <p>No top on 52"H</p> <ul style="list-style-type: none"> • For use under a worksurface or beneath a common top <hr/> <p>Laminate top</p> <ul style="list-style-type: none"> • Square edge laminate top <hr/> <ul style="list-style-type: none"> • Open Line laminate on laminate top 	<p>-\$ 94</p> <hr/> <p>+\$130</p> <hr/> <p>+\$ 67 plus cost of laminate</p>	<p>Specify with <i>no top</i>.</p> <hr/> <p>Specify with <i>laminate top</i> and indicate laminate color number for top and plastic color number for edges.</p> <p>▶ See <i>Surface Materials Reference Manual</i>.</p>

▶ Options, continued on next page

Premium Wood

Pricing: For *Premium wood 2* or *Premium wood 3* pricing, please refer to the *electronic catalog* or *SmartTools*.

Tip: Laminate and wood veneer tops are ³/₁₆" taller than other tops and will add ³/₁₆" to overall case height.



For Canadian Pricing

Multiply U.S. Price by the Canadian price factor.

▶ See page 1 for details.

► Options, continued from previous page

	Options	U.S. Price	Required to Specify
Tops with Flush Steel Front and Proud Steel Front, continued	Wood veneer top		
	• Wood veneer top	+\$394	Specify with <i>wood veneer top</i> and indicate wood color number.
	• Premium wood 2	See information at left	Specify with <i>wood veneer top</i> and indicate Premium wood 2 finish number.
	• Premium wood 3	See information at left	Specify with <i>wood veneer top</i> and indicate Premium wood 3 finish number.
	• Customiz stain on wood veneer top	No cost	Specify with <i>Customiz stain</i> . ► See <i>Surface Materials Reference Manual</i> .
Tops with Proud Wood Front	No top on 52"H		
	• For use under a worksurface or beneath a common top	-\$488	Specify with <i>no top</i> .
	Laminate top		
	• Square edge laminate top	-\$264	Specify with <i>laminate top</i> and indicate laminate color number for top and plastic color number for edges. ► See <i>Surface Materials Reference Manual</i> .
	• Open Line laminate on laminate top	+\$ 67 plus cost of laminate	
Glass Doors	• Frosted glass hinged doors	+\$271	Specify with <i>frosted glass hinged doors</i> .
Drawer Interiors	• HF bar for use on 24"D units only	+\$ 12	Specify with HF bar.
	• Divider package	+\$ 25	Specify with divider package.
	• Rails for use on 18"D units only	+\$ 32	Specify with rails.
Pulls	Proud steel or wood fronts		
	• Contemporary	No cost	Specify with <i>contemporary pull</i> .
	• Handle	No cost	Specify with <i>handle pull</i> .
	• Jazz	+\$ 17 per pull	Specify with <i>jazz pull</i> .
	• Bar	+\$ 25 per pull	Specify with <i>bar pull</i> .
	Proud steel fronts only		
	• c:scape	+\$ 29 per pull	Specify with <i>c:scape pull</i> .
Counterweights	• Package 1	+\$ 86	Specify with <i>counterweight</i> .
	• Package 2	+\$ 96	Specify with <i>counterweight</i> .
	• Package 3	+\$109	Specify with <i>counterweight</i> .
	• Package 4	+\$142	Specify with <i>counterweight</i> .
	• Package 5	+\$180	Specify with <i>counterweight</i> .
Lock and Keying	Lock		
	• Ember Chrome	No cost	Specify with <i>9250 Ember Chrome lock</i> .
	Individual locking drawers on 18"D file		
	• With two drawers	+\$122	Specify with <i>individual lock</i> .
	• With three drawers	+\$244	Specify with <i>individual lock</i> .
	• With four drawers	+\$366	Specify with <i>individual lock</i> .
	Individual locking drawers on 24"D file		
	• With two drawers	+\$136	Specify with <i>individual lock</i> .
	• With three drawers	+\$272	Specify with <i>individual lock</i> .
	• With four drawers	+\$408	Specify with <i>individual lock</i> .
	Keying		
	• Factory- and field-installed keying		► Page 142
Related Products	• Storage accessories		► Page 101
	• Adjustable steel standard shelves		► Page 100
	• Shelf bookends		► Page 104
	• Field-installed tops		► Pages 97–99
	• Counterweights		► Page 105

Premium Wood Pricing: For Premium wood 2 or Premium wood 3 pricing, please refer to the electronic catalog or SmartTools.

Tip: Laminate and wood veneer tops are 3/16" taller than other tops and will add 3/16" to overall case height.

Tip: Glass doors ship separately and must be installed on site.

Tip: Glass door pulls are not the same design as drawer pulls. On flush-front cabinets, glass door pull color must be specified. On proud-front cabinets, glass door pull color will default to color selected for drawer pulls.

Tip: Counterweight packages are recommended based on case size and interior options.

► See *Specification Information* on next page.

Tip: Counterweight option should be specified if the cabinet is not ganged to adjacent cabinets or bolted to the floor or wall.

Tip: Counterweight packages ship separately from case and must be installed on site.



For Canadian Pricing
Multiply U.S. Price by the Canadian price factor.
► See page 1 for details.

► **Specification Information, on next page**

Universal Combination Cabinets with Flush Steel, Proud Steel, and Proud Wood Front, continued

► **Options, on previous page**

Tip: Height dimension listed is for units with 1" top. Overall height will vary if another top is selected.

Tip: Your specification is not complete until you add a suffix to the style number to define the front style (for example, RCC18304A__ becomes RCC18304AF for flush steel front).

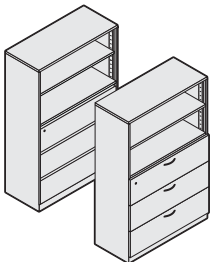
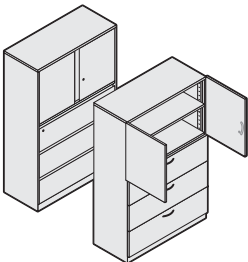
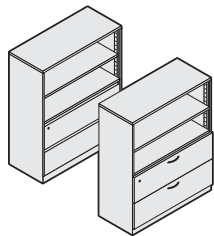
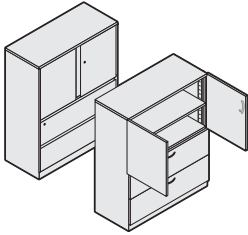

Specification Information

Dimensions		W	H	Recommended Counterweight Package	Style Number	U.S. Base Prices		
D	Flush Steel Front					Proud Steel/Wood Front	Flush Steel Front	Proud Steel Front
						Suffix F	Suffix P	Suffix W

52"H Single-Case Combination Cabinet

24"H Hinged Doors with One Adjustable Shelf, One Fixed Shelf, and Two 12"H Drawers

18"	18 ⁷ / ₈ "	30"	52"	Package 3	RCC18304A__	\$1796	\$2066	\$3103
18"	18 ⁷ / ₈ "	36"	52"	Package 4	RCC18364A__	\$1983	\$2253	\$3290
18"	18 ⁷ / ₈ "	42"	52"	Package 5	RCC18424A__	\$2146	\$2416	\$3453
23 ¹ / ₈ "	24"	30"	52"	Package 3	RCC24304A__	\$1984	\$2254	\$3291
23 ¹ / ₈ "	24"	36"	52"	Package 3	RCC24364A__	\$2189	\$2459	\$3496

Open Cabinet with One Adjustable Shelf, One Fixed Shelf, and Two 12"H Drawers

18"	18 ⁷ / ₈ "	30"	52"	Package 3	RCC18304D__	\$1496	\$1699	N.A.
18"	18 ⁷ / ₈ "	36"	52"	Package 4	RCC18364D__	\$1682	\$1885	N.A.
18"	18 ⁷ / ₈ "	42"	52"	Package 5	RCC18424D__	\$1846	\$2049	N.A.
23 ¹ / ₈ "	24"	30"	52"	Package 3	RCC24304D__	\$1683	\$1886	N.A.
23 ¹ / ₈ "	24"	36"	52"	Package 3	RCC24364D__	\$1887	\$2090	N.A.

65¹/₂"H Single-Case Combination Cabinet

25¹/₂"H Hinged Doors with One Adjustable Shelf, One Fixed Shelf, and Three 12"H Drawers

18"	18 ⁷ / ₈ "	30"	65 ¹ / ₂ "	Package 3	RCC18305E__	\$2125	\$2395	\$3432
18"	18 ⁷ / ₈ "	36"	65 ¹ / ₂ "	Package 3	RCC18365E__	\$2345	\$2615	\$3652
18"	18 ⁷ / ₈ "	42"	65 ¹ / ₂ "	Package 4	RCC18425E__	\$2537	\$2807	\$3844
23 ¹ / ₈ "	24"	30"	65 ¹ / ₂ "	Package 2	RCC24305E__	\$2346	\$2616	\$3653
23 ¹ / ₈ "	24"	36"	65 ¹ / ₂ "	Package 2	RCC24365E__	\$2584	\$2854	\$3891

Open Cabinet with One Adjustable Shelf, One Fixed Shelf, and Three 12"H Drawers

18"	18 ⁷ / ₈ "	30"	65 ¹ / ₂ "	Package 3	RCC18305H__	\$1824	\$2027	N.A.
18"	18 ⁷ / ₈ "	36"	65 ¹ / ₂ "	Package 3	RCC18365H__	\$2044	\$2247	N.A.
18"	18 ⁷ / ₈ "	42"	65 ¹ / ₂ "	Package 4	RCC18425H__	\$2238	\$2441	N.A.
23 ¹ / ₈ "	24"	30"	65 ¹ / ₂ "	Package 2	RCC24305H__	\$2045	\$2248	N.A.
23 ¹ / ₈ "	24"	36"	65 ¹ / ₂ "	Package 2	RCC24365H__	\$2285	\$2488	N.A.

► **Specification Information, continued on next page**



For Canadian Pricing
Multiply U.S. Price by the Canadian price factor.
► See page 1 for details.

► Specification Information, continued from previous page

Tip: Height dimension listed is for units with 1" top. Overall height will vary if another top is selected.

Tip: Your specification is not complete until you add a suffix to the style number to define the front style (for example, RCC18304A__ becomes RCC18304AF for flush steel front).

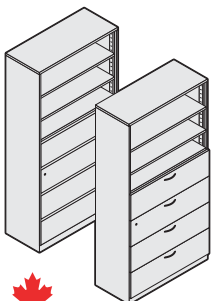
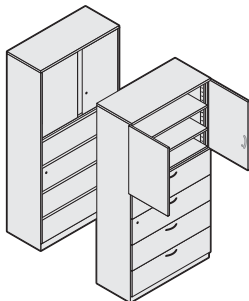
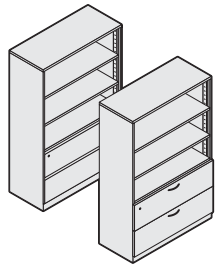
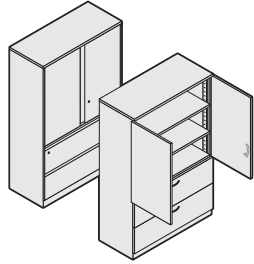

 **For Canadian Pricing**
Multiply U.S. Price by the
Canadian price factor.
► See page 1 for details.

Specification Information

Dimensions		W	H	Recommended Counterweight Package	Style Number	U.S. Base Prices		
D	Front					Flush Steel Front	Proud Steel/Wood Front	Proud Steel/Wood Front

65 1/2"H Single-Case Combination Cabinet, continued

37 1/2"H Hinged Doors with Two Adjustable Shelves, One Fixed Shelf, and Two 12"H Drawers

18"	18 7/8"	30"	65 1/2"	Package 2	RCC18305J__	\$2020	\$2290	\$3327
18"	18 7/8"	36"	65 1/2"	Package 3	RCC18365J__	\$2224	\$2494	\$3531
18"	18 7/8"	42"	65 1/2"	Package 4	RCC18425J__	\$2403	\$2673	\$3710
23 1/8"	24"	30"	65 1/2"	Package 2	RCC24305J__	\$2227	\$2497	\$3534
23 1/8"	24"	36"	65 1/2"	Package 2	RCC24365J__	\$2448	\$2718	\$3755

Open Cabinet with Two Adjustable Shelves, One Fixed Shelf, and Two 12"H Drawers

18"	18 7/8"	30"	65 1/2"	Package 2	RCC18305M__	\$1686	\$1889	N.A.
18"	18 7/8"	36"	65 1/2"	Package 3	RCC18365M__	\$1891	\$2094	N.A.
18"	18 7/8"	42"	65 1/2"	Package 4	RCC18425M__	\$2075	\$2278	N.A.
23 1/8"	24"	30"	65 1/2"	Package 2	RCC24305M__	\$1892	\$2095	N.A.
23 1/8"	24"	36"	65 1/2"	Package 2	RCC24365M__	\$2121	\$2324	N.A.

83 1/2"H Single-Case Combination Cabinet

31 1/2"H Hinged Doors with Two Adjustable Shelves, One Fixed Shelf, and Four 12"H Drawers

18"	18 7/8"	30"	83 1/2"	Package 1	RCC18306N__	\$2563	\$2898	\$3870
18"	18 7/8"	36"	83 1/2"	Package 2	RCC18366N__	\$2826	\$3161	\$4133
18"	18 7/8"	42"	83 1/2"	Package 2	RCC18426N__	\$3056	\$3391	\$4363
23 1/8"	24"	30"	83 1/2"	Not required	RCC24306N__	\$2960	\$3295	\$4267
23 1/8"	24"	36"	83 1/2"	Package 1	RCC24366N__	\$3257	\$3592	\$4564

Open Cabinet with Two Adjustable Shelves, One Fixed Shelf, and Four 12"H Drawers

18"	18 7/8"	30"	83 1/2"	Package 1	RCC18306R__	\$2233	\$2503	N.A.
18"	18 7/8"	36"	83 1/2"	Package 2	RCC18366R__	\$2497	\$2767	N.A.
18"	18 7/8"	42"	83 1/2"	Package 2	RCC18426R__	\$2725	\$2995	N.A.
23 1/8"	24"	30"	83 1/2"	Not required	RCC24306R__	\$2629	\$2899	N.A.
23 1/8"	24"	36"	83 1/2"	Package 1	RCC24366R__	\$2928	\$3198	N.A.

► Specification Information, continued on next page

Universal Combination Cabinets with Flush Steel, Proud Steel, or Proud Wood Front, continued

► **Specification Information, continued from previous page**

Tip: Height dimension listed is for units with 1" top. Overall height will vary if another top is selected.

Tip: Your specification is not complete until you add a suffix to the style number to define the front style (for example, RCC18304A__ becomes RCC18304AF for flush steel front).

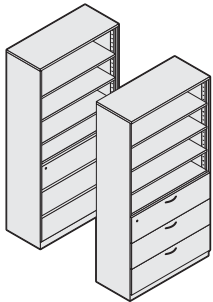
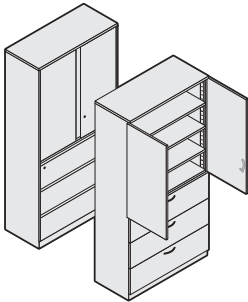

Specification Information

Dimensions		W	H	Recommended Counterweight Package	Style Number	U.S. Base Prices		
D	Flush Steel Front					Proud Steel/Wood Front	Flush Steel Front	Proud Steel Front
						Suffix F	Suffix P	Suffix W

83 1/2" H Single-Case Combination Cabinet, continued

43 1/2" H Hinged Doors with Three Adjustable Shelves, One Fixed Shelf, and Three 12" H Drawers

18"	18 7/8"	30"	83 1/2"	Package 1	RCC18306S__	\$2430	\$2765	\$3737
18"	18 7/8"	36"	83 1/2"	Package 2	RCC18366S__	\$2681	\$3016	\$3988
18"	18 7/8"	42"	83 1/2"	Package 3	RCC18426S__	\$2900	\$3235	\$4207
23 1/8"	24"	30"	83 1/2"	Not required	RCC24306S__	\$2807	\$3142	\$4114
23 1/8"	24"	36"	83 1/2"	Package 1	RCC24366S__	\$3092	\$3427	\$4399

Open Cabinet with Three Adjustable Shelves, One Fixed Shelf, and Three 12" H Drawers

18"	18 7/8"	30"	83 1/2"	Package 1	RCC18306V__	\$2070	\$2273	N.A.
18"	18 7/8"	36"	83 1/2"	Package 2	RCC18366V__	\$2320	\$2523	N.A.
18"	18 7/8"	42"	83 1/2"	Package 3	RCC18426V__	\$2538	\$2741	N.A.
23 1/8"	24"	30"	83 1/2"	Not required	RCC24306V__	\$2448	\$2651	N.A.
23 1/8"	24"	36"	83 1/2"	Package 1	RCC24366V__	\$2730	\$2933	N.A.



For Canadian Pricing

Multiply U.S. Price by the Canadian price factor.

► See page 1 for details.

Universal Storage Cabinets

With Flush Steel, Proud Steel, or Proud Wood Front

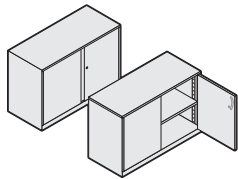

Standard Includes		Required to Specify
<ul style="list-style-type: none"> ▶ Need help? See <i>Storage Specification Guide</i>. 	<ul style="list-style-type: none"> • Storage cabinet: paint price group 1 • 1"H top on units with flush steel or proud steel fronts: paint to match cabinet • 1³/₁₆"H top on units with proud wood fronts: wood veneer to match cabinet • Integral pulls on units with flush steel fronts • Pulls: metal • Hinged doors on units with flush steel or proud steel front: paint to match cabinet • Hinged doors on units with proud wood front: wood veneer to match cabinet • Lock, keyed random: 9201 Polished Chrome • Adjustable shelves: paint to match cabinet • Brackets for adjustable shelves: black • Four adjustable leveling glides 	<ol style="list-style-type: none"> 1 Style number with appropriate front style suffix in the space provided <ul style="list-style-type: none"> F Flush steel front P Proud steel front W Proud wood front 2 Paint color number for cabinet 3 Wood color number for hinged doors and top, if proud wood front selected 4 Pull (see below under required selections) 5 Metal color number for pulls, if proud steel or proud wood front selected 6 Options, if selected (see below) <p>▶ See <i>Surface Materials</i>, page 130.</p>

Required Selections

Pulls

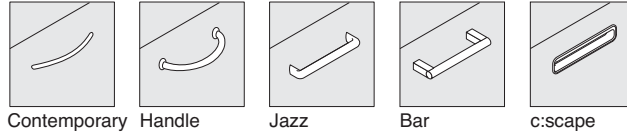

	Options	U.S. Price	Required to Specify
Surface Materials	28"H, 40"H, 52"H, or 65¹/₂"H cabinets		
	• Paint price group 1	No cost	Specify paint color number.
	• Paint price group 2	+\$ 73	Specify paint color number.
	• Paint price group 3	+\$125	Specify paint color number.
	28"H or 40"H cabinets		
	• Customiz stain on proud wood fronts and top	No cost	Specify with <i>Customiz stain</i> . ▶ See <i>Surface Materials Reference Manual</i> .
	52"H, 65¹/₂"H, or 83¹/₂"H cabinets		
	• Customiz stain on proud wood fronts and top	No cost	Specify with <i>Customiz stain</i> . ▶ See <i>Surface Materials Reference Manual</i> .
	83¹/₂"H cabinets		
	• Paint price group 1	No cost	Specify paint color number.
	• Paint price group 2	+\$110	Specify paint color number.
	• Paint price group 3	+\$186	Specify paint color number.
	Premium wood on cabinets		
	• Premium wood 2	See information at left	Specify Premium wood 2 finish number.
	• Premium wood 3	See information at left	Specify Premium wood 3 finish number.
Tops with Flush Steel Front and Proud Steel Front	Security top		
	• For use on 28"H storage cabinets only	No cost	Specify with <i>security top</i> .
	No top on 28"H, 40"H, or 52"H		
	• For use under a worksurface or beneath a common top	-\$ 94	Specify with <i>no top</i> .
	Laminate top		
	• Square edge laminate top	+\$130	Specify with <i>laminate top</i> and indicate laminate color number for top and plastic color number for edges. ▶ See <i>Surface Materials Reference Manual</i> .
	• Open Line laminate on laminate top	+\$ 67 plus cost of laminate	

▶ Options, continued on next page

Premium Wood

Pricing: For Premium wood 2 or Premium wood 3 pricing, please refer to the electronic catalog or *SmartTools*.

Tip: Security top reduces overall height by approximately 1".

Tip: Laminate and wood veneer tops are ³/₁₆" taller than other tops and will add ³/₁₆" to overall case height.

► Options, continued from previous page

	Options	U.S. Price	Required to Specify
Tops with Flush Steel Front and Proud Steel Front, continued	Wood veneer top	+ \$394	Specify with wood veneer top and indicate wood color number.
	• Wood veneer top		Specify with wood veneer top and indicate Premium wood 2 finish number.
	• Premium wood 2	See information at left	Specify with wood veneer top and indicate Premium wood 3 finish number.
	• Premium wood 3	See information at left	Specify with Customiz stain.
	• Customiz stain on wood veneer top	No cost	► See Surface Materials Reference Manual.
Tops with Proud Wood Front	Security top		
	• For use on 28"H storage cabinets only	-\$394	Specify with security top.
	No top on 28"H, 40"H, or 52"H		
	• For use under a worksurface or beneath a common top	-\$488	Specify with no top.
	Laminate top		
	• Square edge laminate top	-\$264	Specify with laminate top and indicate laminate color number for top and plastic color number for edges.
	• Open Line laminate on laminate top	+\$ 67 plus cost of laminate	► See Surface Materials Reference Manual.
Pulls	Proud steel or wood fronts		
	• Contemporary	No cost	Specify with contemporary pull.
	• Handle	No cost	Specify with handle pull.
	• Jazz	+\$ 17 per pull	Specify with jazz pull.
	• Bar	+\$ 25 per pull	Specify with bar pull.
	Proud steel fronts only		
	• c:scape	+\$ 29 per pull	Specify with c:scape pull.
Lock and Keying	Lock		
	• Ember Chrome	No cost	Specify with 9250 Ember Chrome lock.
	Keying		
	• Factory- and field-installed keying		► Page 142
Related Products	• Storage accessories		► Page 101
	• Shelf bookends		► Page 104
	• Field-installed tops		► Pages 97-99

Premium Wood Pricing: For Premium wood 2 or Premium wood 3 pricing, please refer to the electronic catalog or SmartTools.

Tip: Security top reduces overall height by approximately 1".

Tip: Laminate and wood veneer tops are 3/16" taller than other tops and will add 3/16" to overall case height.

Tip: Height dimension listed is for units with 1" top. Overall height will vary if another top is selected.

Tip: Your specification is not complete until you add a suffix to the style number to define the front style (for example, RSC18302A__ becomes RSC18302AF for flush steel front).

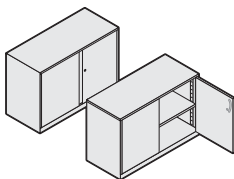

 **For Canadian Pricing**
Multiply U.S. Price by the Canadian price factor.
► See page 1 for details.

Specification Information

Dimensions D	W	H	Counterweight Package	Style Number	U.S. Base Prices		
					Flush Steel Front	Proud Steel Front	Proud Wood Front
					Suffix F	Suffix P	Suffix W

28"H Storage Cabinet

With One Adjustable Shelf

18"	187/8"	30"	28"	Not required	RSC18302A__	\$1076	\$1218	\$2282
18"	187/8"	36"	28"	Not required	RSC18362A__	\$1176	\$1318	\$2382
18"	187/8"	42"	28"	Not required	RSC18422A__	\$1275	\$1417	\$2481
23 1/8"	24"	30"	28"	Not required	RSC24302A__	\$1143	\$1285	\$2349
23 1/8"	24"	36"	28"	Not required	RSC24362A__	\$1248	\$1390	\$2454

► Specification Information, continued on next page

► **Specification Information, continued from previous page**

Tip: Height dimension listed is for units with 1" top. Overall height will vary if another top is selected.

Tip: Your specification is not complete until you add a suffix to the style number to define the front style (for example, RSC18302A__ becomes RSC18302AF for flush steel front).

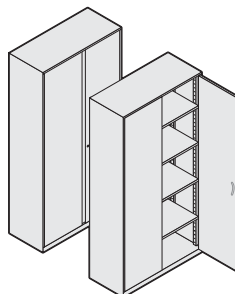
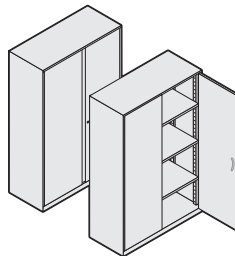
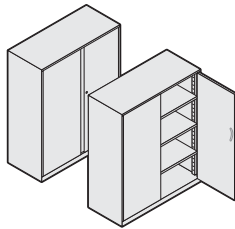
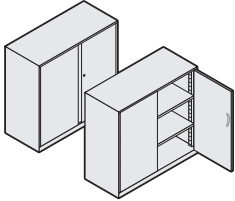

Specification Information

Dimensions		W	H	Counterweight Package	Style Number	U.S. Base Prices		
D	Flush Steel Front					Proud Steel/Wood Front	Flush Steel Front	Proud Steel Front
						Suffix F	Suffix P	Suffix W

40"H Storage Cabinet

With Two Adjustable Shelves

18"	18 ⁷ / ₈ "	30"	40"	Not required	RSC18303C__	\$1223	\$1365	\$2429
18"	18 ⁷ / ₈ "	36"	40"	Not required	RSC18363C__	\$1337	\$1479	\$2543
18"	18 ⁷ / ₈ "	42"	40"	Not required	RSC18423C__	\$1449	\$1591	\$2655
23 ¹ / ₈ "	24"	30"	40"	Not required	RSC24303C__	\$1301	\$1443	\$2507
23 ¹ / ₈ "	24"	36"	40"	Not required	RSC24363C__	\$1424	\$1566	\$2630

52"H Storage Cabinet

With Three Adjustable Shelves

18"	18 ⁷ / ₈ "	30"	52"	Not required	RSC18304F__	\$1455	\$1633	\$2737
18"	18 ⁷ / ₈ "	36"	52"	Not required	RSC18364F__	\$1587	\$1765	\$2869
18"	18 ⁷ / ₈ "	42"	52"	Not required	RSC18424F__	\$1716	\$1894	\$2998
23 ¹ / ₈ "	24"	30"	52"	Not required	RSC24304F__	\$1545	\$1723	\$2827
23 ¹ / ₈ "	24"	36"	52"	Not required	RSC24364F__	\$1685	\$1863	\$2967

65¹/₂"H Storage Cabinet

With Four Adjustable Shelves

18"	18 ⁷ / ₈ "	30"	65 ¹ / ₂ "	Not required	RSC18305K__	\$1529	\$1707	\$2811
18"	18 ⁷ / ₈ "	36"	65 ¹ / ₂ "	Not required	RSC18365K__	\$1671	\$1849	\$2953
18"	18 ⁷ / ₈ "	42"	65 ¹ / ₂ "	Not required	RSC18425K__	\$1808	\$1986	\$3090
23 ¹ / ₈ "	24"	30"	65 ¹ / ₂ "	Not required	RSC24305K__	\$1625	\$1803	\$2907
23 ¹ / ₈ "	24"	36"	65 ¹ / ₂ "	Not required	RSC24365K__	\$1775	\$1953	\$3057

83¹/₂"H Storage Cabinet

With Five Adjustable Shelves

18"	18 ⁷ / ₈ "	30"	83 ¹ / ₂ "	Not required	RSC18306Q__	\$1757	\$1935	\$3039
18"	18 ⁷ / ₈ "	36"	83 ¹ / ₂ "	Not required	RSC18366Q__	\$1919	\$2097	\$3201
18"	18 ⁷ / ₈ "	42"	83 ¹ / ₂ "	Not required	RSC18426Q__	\$2072	\$2250	\$3354
23 ¹ / ₈ "	24"	30"	83 ¹ / ₂ "	Not required	RSC24306Q__	\$1870	\$2048	\$3152
23 ¹ / ₈ "	24"	36"	83 ¹ / ₂ "	Not required	RSC24366Q__	\$2036	\$2214	\$3318



For Canadian Pricing
 Multiply U.S. Price by the Canadian price factor.
 ► See page 1 for details.

Universal Wardrobe Cabinets

With Flush Steel, Proud Steel, or Proud Wood Front

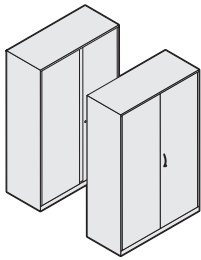

Standard Includes		Required to Specify
<ul style="list-style-type: none"> ▶ Need help? See <i>Storage Specification Guide</i>. 	<ul style="list-style-type: none"> • Wardrobe cabinet: paint price group 1 • 1"H top on units with flush steel or proud steel fronts: paint to match cabinet • 1³/₁₆"H top on units with proud wood fronts: wood veneer to match cabinet • Integral pulls on units with flush steel fronts • Pulls: metal • Hinged doors on units with flush steel or proud steel front: paint to match cabinet • Hinged doors on units with proud wood front: wood veneer to match cabinet • Lock, keyed random: 9201 Polished Chrome • Adjustable shelves: paint to match cabinet • Brackets for adjustable shelves: black • Coat rod: 9201 Polished Chrome • Four adjustable leveling glides 	<ol style="list-style-type: none"> 1 Style number with appropriate front style suffix in the space provided <ul style="list-style-type: none"> F Flush steel front P Proud steel front W Proud wood front 2 Paint color number for cabinet 3 Wood color number for hinged doors and top, if proud wood front selected 4 Pull (see below under required selections) 5 Metal color number for pulls, if proud steel or proud wood front selected 6 Options, if selected (see below) <ul style="list-style-type: none"> ▶ See <i>Surface Materials</i>, page 130.

Required Selections

Pulls

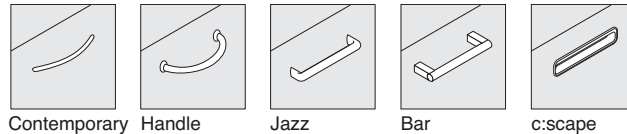

Options	U.S. Price	Required to Specify
Surface Materials 52"H or 65¹/₂"H cabinets <ul style="list-style-type: none"> • Paint price group 1 • Paint price group 2 • Paint price group 3 	No cost +\$ 73 +\$125	Specify paint color number. Specify paint color number. Specify paint color number.
83¹/₂"H cabinets <ul style="list-style-type: none"> • Paint price group 1 • Paint price group 2 • Paint price group 3 	No cost +\$110 +\$186	Specify paint color number. Specify paint color number. Specify paint color number.
<ul style="list-style-type: none"> • Premium wood 2 on proud wood fronts and top • Premium wood 3 on proud wood fronts and top • Customiz stain on proud wood fronts and top 	See information at left See information at left No cost	Specify Premium wood 2 finish number. Specify Premium wood 3 finish number. Specify with <i>Customiz stain</i> . ▶ See <i>Surface Materials Reference Manual</i> .
Tops with Flush Steel Front and Proud Steel Front No top on 52"H <ul style="list-style-type: none"> • For use under a worksurface or beneath a common top 	-\$ 94	Specify with <i>no top</i> .
Laminate top <ul style="list-style-type: none"> • Square edge laminate top • Open Line laminate on laminate top 	+\$130 +\$ 67 plus cost of laminate	Specify with <i>laminate top</i> and indicate laminate color number for top and plastic color number for edges. ▶ See <i>Surface Materials Reference Manual</i> .
Wood veneer top <ul style="list-style-type: none"> • Wood veneer top • Premium wood 2 • Premium wood 3 • Customiz stain on wood veneer top 	+\$394 See information at left See information at left No cost	Specify with <i>wood veneer top</i> and indicate wood color number. Specify with <i>wood veneer top</i> and indicate Premium wood 2 finish number. Specify with <i>wood veneer top</i> and indicate Premium wood 3 finish number. Specify with <i>Customiz stain</i> . ▶ See <i>Surface Materials Reference Manual</i> .

▶ Options, continued on next page

Premium Wood Pricing: For Premium wood 2 or Premium wood 3 pricing, please refer to the electronic catalog or SmartTools.

Tip: Laminate and wood veneer tops are 3/16" taller than other tops and will add 3/16" to overall case height.

 **For Canadian Pricing**
 Multiply U.S. Price by the Canadian price factor.
 ▶ See page 1 for details.

► Options, continued from previous page

Options	U.S. Price	Required to Specify
Tops with Proud Wood Front		
No top on 52"H		
• For use under a worksurface or beneath a common top	-\$488	Specify with <i>no top</i> .
Laminate top		
• Square edge laminate top	-\$264	Specify with <i>laminate top</i> and indicate laminate color number for top and plastic color number for edges. ► See <i>Surface Materials Reference Manual</i> .
• Open Line laminate on laminate top	+\$ 67 plus cost of laminate	
Pulls		
Proud steel or wood fronts		
• Contemporary	No cost	Specify with <i>contemporary pull</i> .
• Handle	No cost	Specify with <i>handle pull</i> .
• Jazz	+\$ 17 per pull	Specify with <i>jazz pull</i> .
• Bar	+\$ 25 per pull	Specify with <i>bar pull</i> .
Proud steel fronts only		
• c:scape	+\$ 29 per pull	Specify with <i>c:scape pull</i> .
Lock and Keying		
Lock		
• Ember Chrome	No cost	Specify with <i>9250 Ember Chrome lock</i> .
Keying		
• Factory- and field-installed keying		► Page 142
Related Products		
• Storage accessories		► Page 101
• Shelf bookends		► Page 104
• Field-installed tops		► Pages 97–99

Tip: Laminate and wood veneer tops are 3/16" taller than other tops and will add 3/16" to overall case height.

Tip: Height dimension listed is for units with 1" top. Overall height will vary if another top is selected.

Tip: Your specification is not complete until you add a suffix to the style number to define the front style (for example, RWC24304A__ becomes RWC24304AF for flush steel front).

Specification Information

Dimensions D	W	H	Counterweight Package	Style Number	U.S. Base Prices		
					Flush Steel Front	Proud Steel Front	Proud Wood Front
					Suffix F	Suffix P	Suffix W

With Side-to-Side Coat Rod

23 1/8"	24"	30"	52"	Not required	RWC24304A__	\$1298	\$1515	\$2531
23 1/8"	24"	36"	52"	Not required	RWC24364A__	\$1424	\$1641	\$2657
23 1/8"	24"	30"	65 1/2"	Not required	RWC24305A__	\$1515	\$1732	\$2748
23 1/8"	24"	36"	65 1/2"	Not required	RWC24365A__	\$1658	\$1875	\$2891
:	:	:	:	:	:	:	:	:

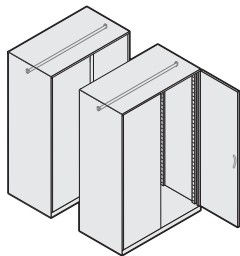

With Side-to-Side Coat Rod and One Fixed Shelf

23 1/8"	24"	30"	83 1/2"	Not required	RWC24306D__	\$2083	\$2300	\$3316
23 1/8"	24"	36"	83 1/2"	Not required	RWC24366D__	\$2252	\$2469	\$3485
:	:	:	:	:	:	:	:	:

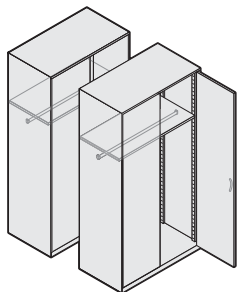

► Specification Information, continued on next page

► **Specification Information, continued from previous page**

Tip: Height dimension listed is for units with 1" top. Overall height will vary if another top is selected.

Tip: Your specification is not complete until you add a suffix to the style number to define the front style (for example, RWC24304A__ becomes RWC24304AF for flush steel front).

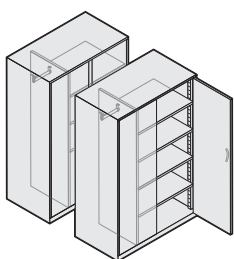
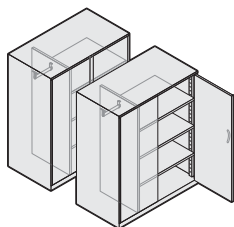

Specification Information									
Dimensions		W	H	Counterweight Package	Style Number	U.S. Base Prices			
D	Front					Flush Steel Front	Proud Steel/Wood Front	Proud Steel Front	Proud Wood Front
						Suffix F	Suffix P	Suffix W	

With Partition, Three Adjustable Shelves, and Coat Rod

23 1/8"	24"	30"	52"	Not required	RWC24304B__	\$1686	\$1903	\$2919
23 1/8"	24"	36"	52"	Not required	RWC24364B__	\$1838	\$2055	\$3071

With Partition, Four Adjustable Shelves, and Coat Rod

23 1/8"	24"	30"	65 1/2"	Not required	RWC24305C__	\$1830	\$2047	\$3063
23 1/8"	24"	36"	65 1/2"	Not required	RWC24365C__	\$1991	\$2208	\$3224



For Canadian Pricing
 Multiply U.S. Price by the Canadian price factor.
 ► See page 1 for details.

Steel Security Tops

For Use with Flush or Proud Front Products

Tip: Tops are for field installation only.

*Tip: Security tops should only be used on units that are positioned under a work-surface—these are **NOT** structural tops.*

Tip: Security top cannot be installed on a file with a lift-up door in the top position.

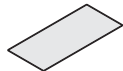
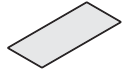

Standard Includes		Required to Specify
▶ Need help? See <i>Storage Specification Guide</i> .	<ul style="list-style-type: none"> • Security top: all paint price groups • Attachment hardware 	1 Style number 2 Paint color number for top ▶ See <i>Surface Materials</i> , page 130.

Specification Information

Dimensions		For Use On	Style Number	U.S. Price
D	W			

Flush Front

18"	30"	Lateral file, storage cabinet	RATF1830F	\$96
18"	36"	Lateral file, storage cabinet	RATF1836F	\$96
18"	42"	Lateral file, storage cabinet	RATF1842F	\$96
23½"	30"	Lateral file, storage cabinet	RATF2430F	\$96
23½"	36"	Lateral file, storage cabinet	RATF2436F	\$96

Proud Front

18⅞"	30"	Lateral file, storage cabinet	RATF1830P	\$96
18⅞"	36"	Lateral file, storage cabinet	RATF1836P	\$96
18⅞"	42"	Lateral file, storage cabinet	RATF1842P	\$96
24"	30"	Lateral file, storage cabinet	RATF2430P	\$96
24"	36"	Lateral file, storage cabinet	RATF2436P	\$96

Specifying

 **For Canadian Pricing**
 Multiply U.S. Price by the Canadian price factor.
 ▶ See page 1 for details.

Square Edge Tops

For Use with Flush and Proud Front Products

Standard Includes		Required to Specify
<ul style="list-style-type: none"> ▶ Need help? See <i>Storage Specification Guide</i>. 	<ul style="list-style-type: none"> • 1³/₁₆"H top with square edge profile on all sides: laminate or wood • Attachment hardware 	<ol style="list-style-type: none"> 1 Style number with appropriate front style suffix in the space provided <ul style="list-style-type: none"> F Flush steel front P Proud steel or proud wood front 2 Laminate or wood color number for top 3 Plastic color number for 1 mm edges of laminate top 4 Options, if selected (see below) <p>▶ See <i>Surface Materials</i>, page 130.</p>

Options	U.S. Price	Required to Specify
Surface Laminate top <ul style="list-style-type: none"> • Open Line laminate 	+\$67 plus cost of laminate	<p>▶ See <i>Surface Materials Reference Manual</i>.</p>
Wood veneer top <ul style="list-style-type: none"> • Customiz stain on wood veneer top • Full-fill finish on wood veneer 	No cost Prices below and at right	<p>Specify with <i>Customiz stain</i>.</p> <p>▶ See <i>Surface Materials Reference Manual</i>. Specify with <i>full-fill finish</i> and select wood color number.</p> <p>▶ See <i>Surface Materials Reference Manual</i>.</p>

Tip: Your specification is not complete until you add a suffix to the style number to define the front style (for example, RATL1830__ becomes RATL1830F for a top to be used on a flush front unit).

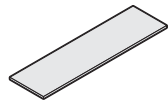
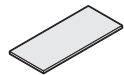

Specification Information						
Dimensions		Style Number		U.S. Base Prices		Option
D	W	H	Number	Flush Steel Front	Proud Steel or Proud Wood Front	(Add \$ to Base Price)
Flush Steel Front	Proud Steel/Proud Wood			Suffix F	Suffix P	Full-Fill Finish

Individual File Laminate Tops

D	W	H	Style Number	Flush Steel Front	Proud Steel or Proud Wood Front	Option
18"	18 ⁷ / ₈ "	30"	RATL1830__	\$181	\$181	N.A.
18"	18 ⁷ / ₈ "	36"	RATL1836__	\$196	\$196	N.A.
18"	18 ⁷ / ₈ "	42"	RATL1842__	\$213	\$213	N.A.
23 ¹ / ₈ "	24"	30"	RATL2430__	\$201	\$201	N.A.
23 ¹ / ₈ "	24"	36"	RATL2436__	\$213	\$213	N.A.

Laminate Common Tops

D	W	H	Style Number	Flush Steel Front	Proud Steel or Proud Wood Front	Option
18"	18 ⁷ / ₈ "	60 ¹ / ₁₆ "	RATCL1860__	\$295	\$295	N.A.
18"	18 ⁷ / ₈ "	66 ¹ / ₁₆ "	RATCL1866__	\$340	\$340	N.A.
18"	18 ⁷ / ₈ "	72 ¹ / ₁₆ "	RATCL1872__	\$382	\$382	N.A.
18"	18 ⁷ / ₈ "	78 ¹ / ₁₆ "	RATCL1878__	\$486	\$486	N.A.
18"	18 ⁷ / ₈ "	84 ¹ / ₁₆ "	RATCL1884__	\$549	\$549	N.A.
18"	18 ⁷ / ₈ "	90 ¹ / ₈ "	RATCL1890__	\$612	\$612	N.A.
18"	18 ⁷ / ₈ "	96 ¹ / ₈ "	RATCL1896__	\$673	\$673	N.A.
18"	18 ⁷ / ₈ "	108 ¹ / ₈ "	RATCL18108__	\$810	\$810	N.A.

▶ **Specification Information, continued on next page**

 **For Canadian Pricing**
 Multiply U.S. Price by the Canadian price factor.
 ▶ See page 1 for details.

► **Specification Information, continued from previous page**

Tip: Your specification is not complete until you add a suffix to the style number to define the front style (for example, RATL1830__ becomes RATL1830F for a top to be used on a flush front unit).

Specification Information

Dimensions		W	H	Style Number	U.S. Base Prices		Option (Add \$ to Base Price)	
D					Flush Steel Front	Proud Steel/ Proud Wood		Flush Steel Front
						Suffix F	Suffix P	Full-Fill Finish

Laminate Common Tops, continued

23 1/8"	24"	60 1/16"	1 3/16"	RATCL2460__	\$ 309	\$ 309	N.A.
23 1/8"	24"	66 1/16"	1 3/16"	RATCL2466__	\$ 346	\$ 346	N.A.
23 1/8"	24"	72 1/16"	1 3/16"	RATCL2472__	\$ 391	\$ 391	N.A.
23 1/8"	24"	90 1/8"	1 3/16"	RATCL2490__	\$ 655	\$ 655	N.A.
23 1/8"	24"	96 1/8"	1 3/16"	RATCL2496__	\$ 719	\$ 719	N.A.
23 1/8"	24"	108 1/8"	1 3/16"	RATCL24108__	\$ 868	\$ 868	N.A.
36 1/16"	37 13/16"	36"	1 3/16"	RATCL3636__	\$ 373	\$ 373	N.A.
36 1/16"	37 13/16"	72 1/16"	1 3/16"	RATCL3672__	\$ 513	\$ 513	N.A.
46 5/16"	48 1/16"	36"	1 3/16"	RATCL4836__	\$ 420	\$ 420	N.A.
46 5/16"	48 1/16"	72 1/16"	1 3/16"	RATCL4872__	\$ 578	\$ 578	N.A.

Individual File Wood Tops

18"	18 7/8"	30"	1 3/16"	RATW1830__	\$ 469	\$ 469	+\$28
18"	18 7/8"	36"	1 3/16"	RATW1836__	\$ 480	\$ 480	+\$28
18"	18 7/8"	42"	1 3/16"	RATW1842__	\$ 540	\$ 540	+\$28
23 1/8"	24"	30"	1 3/16"	RATW2430__	\$ 487	\$ 487	+\$28
23 1/8"	24"	36"	1 3/16"	RATW2436__	\$ 500	\$ 500	+\$28

Wood Common Tops

18"	18 7/8"	60 1/16"	1 3/16"	RATCW1860__	\$ 662	\$ 662	+\$46
18"	18 7/8"	66 1/16"	1 3/16"	RATCW1866__	\$ 698	\$ 698	+\$46
18"	18 7/8"	72 1/16"	1 3/16"	RATCW1872__	\$ 733	\$ 733	+\$46
18"	18 7/8"	78 1/16"	1 3/16"	RATCW1878__	\$ 876	\$ 876	+\$46
18"	18 7/8"	84 1/16"	1 3/16"	RATCW1884__	\$ 996	\$ 996	+\$67
18"	18 7/8"	90 1/8"	1 3/16"	RATCW1890__	\$1054	\$1054	+\$67
18"	18 7/8"	96 1/8"	1 3/16"	RATCW1896__	\$1161	\$1161	+\$67
23 1/8"	24"	60 1/16"	1 3/16"	RATCW2460__	\$ 680	\$ 680	+\$46
23 1/8"	24"	66 1/16"	1 3/16"	RATCW2466__	\$ 715	\$ 715	+\$67
23 1/8"	24"	72 1/16"	1 3/16"	RATCW2472__	\$ 759	\$ 759	+\$67
23 1/8"	24"	90 1/8"	1 3/16"	RATCW2490__	\$1126	\$1126	+\$67
23 1/8"	24"	96 1/8"	1 3/16"	RATCW2496__	\$1242	\$1242	+\$67

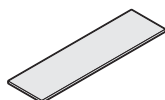
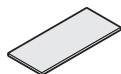
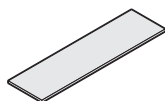

Specifying

 **For Canadian Pricing**
 Multiply U.S. Price by the Canadian price factor.
 ► See page 1 for details.

Adjustable Steel Standard Shelves

For Use with Combination Cabinets, Wardrobe Cabinets, and Storage Cabinets

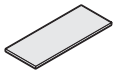

Tip: Adjustable shelves are for field installation only.

Tip: When ordering additional adjustable shelves for wardrobe cabinets with partitions, note that the partition and coat space occupy 6" of the case interior. Order shelves 6" shorter than the overall width of the cabinet.

Standard Includes	Required to Specify
<ul style="list-style-type: none"> ▶ Need help? See <i>Storage Specification Guide</i>. • ¾"H adjustable shelf: all paint price groups • Set of four adjustable brackets: black only 	<ul style="list-style-type: none"> 1 Style number 2 Paint color number for shelf ▶ See <i>Surface Materials</i>, page 130.

Specification Information

• Dimensions	• Style	• U.S.
D W	Number	Price

For Use with Combination Cabinets, Wardrobe Cabinets, and Storage Cabinets

18"	30"	RXSA1830	\$66
18"	36"	RXSA1836	\$69
18"	42"	RXSA1842	\$90
24"	24"	RXSA2424	\$66
24"	30"	RXSA2430	\$69
24"	36"	RXSA2436	\$81



For Canadian Pricing

Multiply U.S. Price by the Canadian price factor.

▶ See page 1 for details.

Rails

For Use in Pedestals Manufactured after February 22, 2004
 For Use in Universal Towers and Universal Workstation Verticals

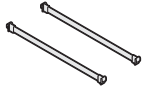

Tip: Two rails per drawer accommodate side-to-side filing of letter-, A4-, and legal-size hanging folders. Exception: Legal-size file folders cannot be filed in 18"D pedestals.

Tip: For pedestals manufactured on or before February 22, 2004, see Service Parts catalog.

Standard Includes	Required to Specify
<ul style="list-style-type: none"> ▶ Need help? See <i>Storage Specification Guide</i>. • Package of two rails: black only 	Style number

Specification Information		
• Width	• Style Number	• U.S. Price
12"	RXADRL15	\$23
⋮	⋮	⋮

Dividers

For Use in Pedestals Manufactured after February 22, 2004
 For Use in Universal Towers and Universal Workstation Verticals

Tip: For pedestals manufactured on or before February 22, 2004, see Service Parts catalog.

Standard Includes	Required to Specify
<ul style="list-style-type: none"> ▶ Need help? See <i>Storage Specification Guide</i>. • Package of dividers: black only 	Style number

Specification Information			
• Width	• Quantity	• Style Number	• U.S. Price
⋮	⋮	⋮	⋮

For Use in 6"H Drawers			
12"	2	RDV1506	\$ 36
⋮	⋮	⋮	⋮

For Use in 12"H Drawers			
12"	2	RDV1512	\$ 39
12"	10	RDV151210	\$183
⋮	⋮	⋮	⋮



For Canadian Pricing
 Multiply U.S. Price by the Canadian price factor.
 ▶ See page 1 for details.

Pencil Tray

For Use in Pedestals Manufactured after February 22, 2004
 For Use in Universal Towers and Universal Workstation Verticals

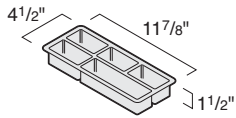

Tip: Pedestals with box drawers include one pencil tray per pedestal.

Tip: For pedestals manufactured on or before February 22, 2004, see Service Parts catalog.

Standard Includes	Required to Specify
-------------------	---------------------

- | | | |
|--|---|--------------|
| <ul style="list-style-type: none"> ▶ Need help? See <i>Storage Specification Guide</i>. | <ul style="list-style-type: none"> • Pencil tray: black only | Style number |
|--|---|--------------|

Specification Information

• Style Number	• U.S. Price
RPXDPT	\$32

Reference Shelf

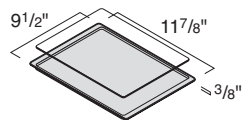

Standard Includes	Required to Specify
-------------------	---------------------

- | | | |
|--|---|--------------|
| <ul style="list-style-type: none"> ▶ Need help? See <i>Storage Specification Guide</i>. | <ul style="list-style-type: none"> • Reference shelf: black only • Insert: clear plastic only | Style number |
|--|---|--------------|

Specification Information

• Style Number	• U.S. Price
RPXDRS	\$44

Hanging Folder Bars

For Use with Universal Lateral Files and Universal Combination Cabinets Manufactured on or after October 17, 2005
 For Use with 900 Series, 800 Series, and 200 Series Lateral Files Manufactured on or after May 5, 1997

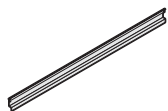

Standard Includes	Required to Specify
-------------------	---------------------

- | | | |
|--|--|--------------|
| <ul style="list-style-type: none"> ▶ Need help? See <i>Storage Specification Guide</i>. | <ul style="list-style-type: none"> • Hanging folder bar: black only | Style number |
|--|--|--------------|

Specification Information

• Width	• Style Number	• U.S. Price
30"	RAHF30	\$12
36"	RAHF36	\$12
42"	RAHF42	\$12

For Canadian Pricing
 Multiply U.S. Price by the Canadian price factor.
 ▶ See page 1 for details.

Rails

For Use with Lateral Files and Combination Cabinets

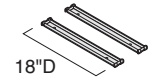

18"D

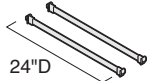

24"D

Tip: All drawer sizes require two rails per drawer for maximum capacity front-to-back filing.

Standard Includes

- ▶ Need help? See *Storage Specification Guide*.
- Package of two or four rails: black only

Required to Specify

Style number

Specification Information

• Depth	• Style Number	• U.S. Price
.....

Package of Two

18"	800RW	\$32
24"	RXADRL24	\$23

Package of Four

24"	RXADRL2442	\$43
.....

Dividers

For Use in Lateral Files and Combination Cabinets

Standard Includes

- ▶ Need help? See *Storage Specification Guide*.
- Carton of three dividers: black only

Required to Specify

Style number

Specification Information

• Dimensions			• Style Number	• U.S. Price
D	W	H		
.....

For Use in 12"H Drawers of 12"H Roll-Out Shelves

11 ⁷ / ₈ "	1/16"	6 ¹ / ₄ "	800DV12	\$25
----------------------------------	-------	---------------------------------	----------------	------

For Use in 6"H Roll-Out Shelves or Drawers and 9"H Drawers

13 ¹ / ₂ "	1/16"	3 ⁵ / ₈ "	800DV6	\$25
.....

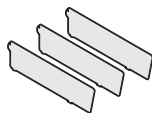

For Canadian Pricing

Multiply U.S. Price by the Canadian price factor.

- ▶ See page 1 for details.

Shelf Divider Assembly

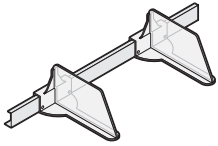

Standard Includes	Required to Specify
<ul style="list-style-type: none"> ▶ Need help? See <i>Storage Specification Guide</i>. • Divider bracket: black only • Two dividers: clear plastic 	Style number

Specification Information		
• Width	• Style Number	• U.S. Price
30"	RASTDIV30	\$90
36"	RASTDIV36	\$90
42"	RASTDIV42	\$90
:	:	:

Bookends

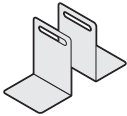

Standard Includes	Required to Specify
<ul style="list-style-type: none"> ▶ Need help? See <i>Storage Specification Guide</i>. • Package of two or twenty bookends: 6695 Midnight only 	Style number

Specification Information		
• Style Number	• Quantity	• U.S. Price
KDIV02	2	\$ 28
KDIV20	20	\$262
:	:	:



For Canadian Pricing
 Multiply U.S. Price by the Canadian price factor.
 ▶ See page 1 for details.

Wood Drawer Pulls

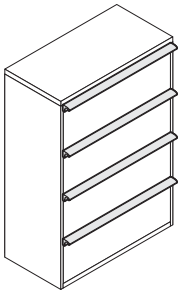

Standard Includes		Required to Specify
<ul style="list-style-type: none"> ▶ Need help? See <i>Storage Specification Guide</i>. 	<ul style="list-style-type: none"> • Pull: wood 	<ul style="list-style-type: none"> 1 Style number 2 Wood color number 3 Options, if selected (see below) ▶ See <i>Surface Materials</i>, page 130.

Options	U.S. Price	Required to Specify
Surface Materials <ul style="list-style-type: none"> • Customiz stain 	No cost	<ul style="list-style-type: none"> Specify with <i>Customiz stain</i>. ▶ See <i>Surface Materials Reference Manual</i>.

Specification Information		
Width	Style Number	U.S. Price
15"	RPULL15W	\$144
30"	RPULL30W	\$197
36"	RPULL36W	\$223
42"	RPULL42W	\$249
:	:	:

Counterweight Packages

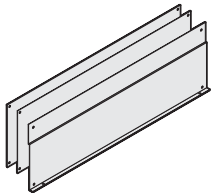

Standard Includes		Required to Specify
<ul style="list-style-type: none"> ▶ Need help? See <i>Storage Specification Guide</i>. 	<ul style="list-style-type: none"> • Counterweight: black only • Attachment hardware 	<ul style="list-style-type: none"> Style number

Specification Information		
Package Number	Style Number	U.S. Price
Package 1	RAACW1	\$ 86
Package 2	RAACW2	\$ 96
Package 3	RAACW3	\$109
Package 4	RAACW4	\$142
Package 5	RAACW5	\$180
:	:	:

 **For Canadian Pricing**
 Multiply U.S. Price by the Canadian price factor.
 ▶ See page 1 for details.

Anchor Bracket Package

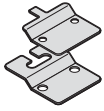

Tip: Four bracket packages are required for each cabinet.

Standard Includes	Required to Specify
<ul style="list-style-type: none"> ▶ Need help? See <i>Storage Specification Guide</i>. 	<ul style="list-style-type: none"> • Two-piece anchor bracket and attachment hardware
	Style number

Specification Information

• Style Number	• U.S. Price
RAANBRK	\$34



For Canadian Pricing
 Multiply U.S. Price by the Canadian price factor.
 ▶ See page 1 for details.

Ellipse-Style Lateral File Tops X4/16

Ellipse-Style Lateral File
Tops

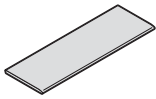

Tip: Ellipse-style lateral file tops are field installed.

Tip: Top can be installed on Universal lateral files or cabinets with proud steel or proud wood fronts.

Standard Includes		Required to Specify
<ul style="list-style-type: none"> ▶ Need help? Product details, page 18 	<ul style="list-style-type: none"> • Top: laminate or wood • Top end: plastic default or wood • Attachment hardware 	<ul style="list-style-type: none"> 1 Style number 2 Laminate or wood color number for top 3 Options, if selected (see below) ▶ See <i>Surface Materials</i>, page 130.

Options	U.S. Price	Required to Specify
Surface Materials <ul style="list-style-type: none"> • Open Line laminate • Full-fill finish on wood top • Customiz stain on wood top 	<ul style="list-style-type: none"> +\$67 plus cost of laminate Prices below No cost 	<ul style="list-style-type: none"> ▶ See <i>Surface Materials Reference Manual</i>. Specify with <i>full-fill finish</i> and select wood color number. ▶ See <i>Surface Materials</i>, page 130. ▶ See <i>Surface Materials Reference Manual</i>.

Specification Information						
Dimensions			Cartons Shipped	Style Number	U.S. Base Price	Option (Add \$ to Base Price)
D	W	H				

Laminate						
19"	30"	1 1/4"	1	ASGT1930L5 X4/16	\$ 306	N.A.
19"	60"	1 1/4"	1	ASGT1960L4 X4/16	\$ 537	N.A.
19"	90"	1 1/4"	1	ASGT1990L3 X4/16	\$ 869	N.A.

Wood						
19"	30"	1 1/4"	1	ASGT1930V3 X4/16	\$ 845	+\$28
19"	60"	1 1/4"	1	ASGT1960V2 X4/16	\$1240	+\$46
19"	90"	1 1/4"	1	ASGT1990V1 X4/16	\$1799	+\$67

Specifying

For Canadian Pricing
Multiply U.S. Price by the Canadian price factor.
▶ See page 1 for details.

X4/16 = Last order entry
April 17, 2016

Internode Power and Communication Components

Internode Floor Power Infeeds

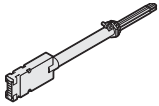

Tip: Floor power infeed cannot be used in New York City. Use a multipurpose power infeed instead.

Standard Includes	Required to Specify
<ul style="list-style-type: none"> ▶ Need help? Product details, page 39 • Junction box fittings for hardwired connection • Liquid-tight flexible conduit: black plastic 	Style number

Related Products
<ul style="list-style-type: none"> • Internode power modules ▶ Page 110

Specification Information

Length	Style Number	U.S. Price
4-Circuit, 3+1		
6'	GFUFFH6X	\$234
12'	GFUFFH12X	\$310
4-Circuit, 2+2		
6'	GFUFFH6Y	\$234
12'	GFUFFH12Y	\$310
3-Circuit, Separate Neutrals		
6'	GFUFFH6Z	\$234
12'	GFUFFH12Z	\$234



For Canadian Pricing
 Multiply U.S. Price by the Canadian price factor.
 ▶ See page 1 for details.

Internode Multipurpose Power Infeeds

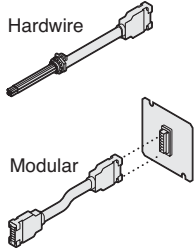

Tip: Modular connector receptacle covers a standard 4⁹/₁₆" square junction box.

Standard Includes	Required to Specify
-------------------	---------------------

- | | | |
|---|--|---|
| <ul style="list-style-type: none"> ▶ Need help? Product details, page 39 | <ul style="list-style-type: none"> • Junction box fittings for hardwired connection, if selected • Modular connector, if selected • Modular connector receptacle included with modular option • Modular infeed cover, if selected: plastic • Conduit: metal | <ul style="list-style-type: none"> 1 Style number 2 Plastic color number for modular infeed cover, if selected ▶ See <i>Surface Materials</i>, page 130. |
|---|--|---|

Related Products

- | | |
|---|--|
| <ul style="list-style-type: none"> • Internode power modules | <ul style="list-style-type: none"> ▶ Page 110 |
|---|--|

Specification Information		
Length and Connection	Style Number	U.S. Price

4-Circuit, 3+1

12' Hardwire	GSGUFMH12X	\$350
12' Modular	GSGUFMM12X	\$448
24' Hardwire	GSGUFMH24X	\$506
24' Modular	GSGUFMM24X	\$598
·	·	·

4-Circuit, 2+2

12' Hardwire	GSGUFMH12Y	\$350
12' Modular	GSGUFMM12Y	\$448
24' Hardwire	GSGUFMH24Y	\$506
24' Modular	GSGUFMM24Y	\$598
·	·	·

3-Circuit, Separate Neutrals

12' Hardwire	GSGUFMH12Z	\$350
12' Modular	GSGUFMM12Z	\$448
24' Hardwire	GSGUFMH24Z	\$506
24' Modular	GSGUFMM24Z	\$598
·	·	·

Modular Infeed Cover

N.A.	GSGUFC	\$ 45
·	·	·

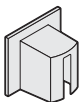

 **For Canadian Pricing**
Multiply U.S. Price by the Canadian price factor.
▶ See page 1 for details.

Internode Power Modules

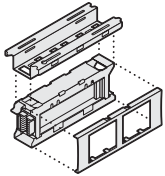

Tip: Remember to specify receptacles separately.
▶ Page 115

Standard Includes	Required to Specify
<ul style="list-style-type: none"> ▶ Need help? Product details, page 39 	<ul style="list-style-type: none"> • Power block and enclosing housing: 4793 Solar Black only • Four modular receptacle attachment points • Mounting bracket, if selected: 6653 Solar Black only • Two covers: 6653 Solar Black only • Mounting hardware package
Style number	

Related Products
<ul style="list-style-type: none"> • Internode mounting bracket ▶ Page 111 • Internode modular harnesses ▶ Page 112 • Internode communication module ▶ Page 114 • Internode receptacles ▶ Page 115 • Internode cord and cable manager ▶ Page 120

Specification Information					
• Dimensions	• Includes			• Style Number	• U.S. Price
	D	W	H		

4-Circuit, 3+1

3"	10"	3 1/2"	Yes	GFUPMBX	\$289
3"	10"	3 1/2"	No	GFUPMX	\$252

Block-to-Block Connector

1 3/16"	1 5/8"	1 15/16"	N.A.	GSGUBCX	\$ 58
---------	--------	----------	------	----------------	-------

For Use in New York City

3"	10"	3 1/2"	Yes	GFUPMBXNYC	\$289
3"	10"	3 1/2"	No	GFUPMXNYC	\$252

4-Circuit, 2+2

3"	10"	3 1/2"	Yes	GFUPMBY	\$289
3"	10"	3 1/2"	No	GFUPMY	\$252

Block-to-Block Connector

1 3/16"	1 5/8"	1 15/16"	N.A.	GSGUBCY	\$ 58
---------	--------	----------	------	----------------	-------

For Use in New York City

3"	10"	3 1/2"	Yes	GFUPMBYNYC	\$289
3"	10"	3 1/2"	No	GFUPMYNYC	\$252

3-Circuit, Separate Neutrals

3"	10"	3 1/2"	Yes	GFUPMBZ	\$289
3"	10"	3 1/2"	No	GFUPMZ	\$252

Block-to-Block Connector

1 3/16"	1 5/8"	1 15/16"	N.A.	GSGUBCZ	\$ 58
---------	--------	----------	------	----------------	-------

For Use in New York City

3"	10"	3 1/2"	Yes	GFUPMBZNYC	\$289
3"	10"	3 1/2"	No	GFUPMZNYC	\$252

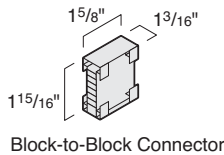

Block-to-Block Connector

 **For Canadian Pricing**
Multiply U.S. Price by the Canadian price factor.
▶ See page 1 for details.

Internode Mounting Bracket

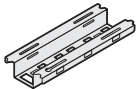

Tip: Mounting bracket supports either a communication module or a power module.

Tip: Mounting bracket is located in front of power beam for ease of access for modular harnesses.

Standard Includes		Required to Specify
<ul style="list-style-type: none"> ▶ Need help? Product details, page 40 	<ul style="list-style-type: none"> • Mounting bracket: 4793 Solar Black only • Mounting hardware package 	Style number

Related Products	
<ul style="list-style-type: none"> • Internode power modules • Internode communication module • Internode cord and cable manager 	<ul style="list-style-type: none"> ▶ Page 110 ▶ Page 114 ▶ Page 120

Specification Information

Style Number	U.S. Price
GFUMB	\$39
.	.

Specifying

 **For Canadian Pricing**
Multiply U.S. Price by the Canadian price factor.
▶ See page 1 for details.

Internode Modular Harnesses

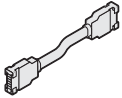

Tip: Harness can pass through access slot in power beam.

Standard Includes	Required to Specify
<ul style="list-style-type: none"> Need help? Product details, page 40 Harness 	Style number

Related Products
<ul style="list-style-type: none"> Internode power modules

Specification Information

Length	Style Number	U.S. Price
--------	--------------	------------

4-Circuit, 3+1

12"	GSGUH12X	\$131
22"	GSGUH22X	\$131
28"	GSGUH28X	\$131
32"	GSGUH32X	\$131
38"	GSGUH38X	\$131
44"	GSGUH44X	\$149
50"	GSGUH50X	\$149
54"	GSGUH54X	\$158
64"	GSGUH64X	\$175
76"	GSGUH76X	\$188
88"	GSGUH88X	\$215
100"	GSGUH100X	\$233
120"	GSGUH120X	\$275
144"	GSGUH144X	\$312

Harness-to-Harness Connector

	GSGUHCX	\$ 58
--	----------------	-------

Modular-to-Hardwire Harness

108"	GSGUHHX	\$175
------	----------------	-------

4-Circuit, 2+2

12"	GSGUH12Y	\$131
22"	GSGUH22Y	\$131
28"	GSGUH28Y	\$131
32"	GSGUH32Y	\$131
38"	GSGUH38Y	\$131
44"	GSGUH44Y	\$149
50"	GSGUH50Y	\$149

► **Specification Information, continued on next page**



For Canadian Pricing
 Multiply U.S. Price by the Canadian price factor.
 ► See page 1 for details.

► Specification Information, continued from previous page

Specification Information

Length	Style Number	U.S. Price
--------	--------------	------------

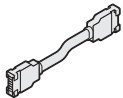

4-Circuit, 2+2, continued

54"	GSGUH54Y	\$158
64"	GSGUH64Y	\$175
76"	GSGUH76Y	\$188
88"	GSGUH88Y	\$215
100"	GSGUH100Y	\$233
120"	GSGUH120Y	\$275
144"	GSGUH144Y	\$312

Modular-to-Hardwire Harness

108"	GSGUHHY	\$175
:	:	:

3-Circuit, Separate Neutrals

12"	GSGUH12Z	\$131
22"	GSGUH22Z	\$131
28"	GSGUH28Z	\$131
32"	GSGUH32Z	\$131
38"	GSGUH38Z	\$131
44"	GSGUH44Z	\$149
50"	GSGUH50Z	\$149
54"	GSGUH54Z	\$158
64"	GSGUH64Z	\$175
76"	GSGUH76Z	\$188
88"	GSGUH88Z	\$215
100"	GSGUH100Z	\$233
120"	GSGUH120Z	\$275
144"	GSGUH144Z	\$312

Modular-to-Hardwire Harness

108"	GSGUHHZ	\$175
:	:	:



For Canadian Pricing
Multiply U.S. Price by the
Canadian price factor.
► See page 1 for details.

Internode Communication Module

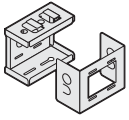

Tip: Communication modules can be supported by mounting bracket, power module, or applied directly to the underside of a worksurface.

Standard Includes	Required to Specify
<ul style="list-style-type: none"> ▶ Need help? Product details, page 40 	<ul style="list-style-type: none"> • Two-piece communication module: 4793 Solar Black only • One cover, used to adapt NEMA opening to modular furniture faceplate opening • Mounting hardware package

Related Products
<ul style="list-style-type: none"> • Internode power module ▶ Page 110 • Internode mounting bracket ▶ Page 111

Specification Information				
• Dimensions			• Style	• U.S.
D	W	H	Number	Price
3"	5"	4"	GFUSCM	\$57



For Canadian Pricing
 Multiply U.S. Price by the Canadian price factor.
 ▶ See page 1 for details.

Internode Receptacles

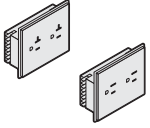

Tip: Receptacles are specified individually so you can order exactly the quantity you need.

Standard Includes	Required to Specify
<ul style="list-style-type: none"> ▶ Need help? Product details, page 40 • Individual receptacles: plastic 	<ul style="list-style-type: none"> 1 Style number 2 Plastic color number for receptacle ▶ See <i>Surface Materials</i>, page 130.

Related Products	
<ul style="list-style-type: none"> • Internode power modules • Internode convenience tri-receptacles with power cord and plug 	<ul style="list-style-type: none"> ▶ Page 110 ▶ Page 118

Specification Information

Line	System Ground		Isolated Ground	
	Style Number	U.S. Price	Style Number	U.S. Price

4-Circuit, 3+1

15-Amp Receptacles

Line 1	GSGUR1SSX	\$46	GSGUR1SGX	\$58
Line 2	GSGUR2SSX	\$46	GSGUR2SGX	\$58
Line 3	GSGUR3SSX	\$46	GSGUR3SGX	\$58
Line 4	GSGUR4SSX	\$46	GSGUR4SGX	\$58

20-Amp Receptacles

Line 1	GSGUR1TSX	\$72	GSGUR1TGX	\$88
Line 2	GSGUR2TSX	\$72	GSGUR2TGX	\$88
Line 3	GSGUR3TSX	\$72	GSGUR3TGX	\$88
Line 4	GSGUR4TSX	\$72	GSGUR4TGX	\$88

4-Circuit, 2+2

15-Amp Receptacles

Line 1	GSGUR1SSY	\$46	GSGUR1SGY	\$58
Line 2	GSGUR2SSY	\$46	GSGUR2SGY	\$58
Line 3	GSGUR3SSY	\$46	GSGUR3SGY	\$58
Line 4	GSGUR4SSY	\$46	GSGUR4SGY	\$58

20-Amp Receptacles

Line 1	GSGUR1TSY	\$72	GSGUR1TGY	\$88
Line 2	GSGUR2TSY	\$72	GSGUR2TGY	\$88
Line 3	GSGUR3TSY	\$72	GSGUR3TGY	\$88
Line 4	GSGUR4TSY	\$72	GSGUR4TGY	\$88

▶ **Specification Information, continued on next page**



For Canadian Pricing
Multiply U.S. Price by the
Canadian price factor.
▶ See page 1 for details.

► **Specification Information, continued from previous page**

Specification Information

Line	System Ground		Isolated Ground	
	Style Number	U.S. Price	Style Number	U.S. Price
3-Circuit, Separate Neutrals				
15-Amp Receptacles				
Line 1	GSGUR1SSZ	\$46	GSGUR1SGZ	\$58
Line 2	GSGUR2SSZ	\$46	GSGUR2SGZ	\$58
Line 3	GSGUR3SSZ	\$46	GSGUR3SGZ	\$58
20-Amp Receptacles				
Line 1	GSGUR1TSZ	\$72	GSGUR1TGZ	\$88
Line 2	GSGUR2TSZ	\$72	GSGUR2TGZ	\$88
Line 3	GSGUR3TSZ	\$72	GSGUR3TGZ	\$88

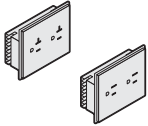

For Canadian Pricing

Multiply U.S. Price by the Canadian price factor.

► See page 1 for details.

Internode Convenience Tri-Receptacles with Modular Harness

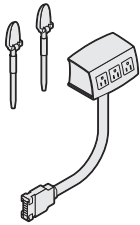

Standard Includes		Required to Specify	
<ul style="list-style-type: none"> ▶ Need help? Product details, page 40 	<ul style="list-style-type: none"> • Convenience tri-receptacle housing: plastic • Three receptacles: black • Harness with modular connector for attachment to end of power module • Conduit: metallic • Mounting clamp kit 	<ul style="list-style-type: none"> 1 Style number 2 Plastic color number for tri-receptacle housing 3 Options, if selected (see below) ▶ See <i>Surface Materials</i>, page 130. 	
Options		U.S. Price	Required to Specify
Outfeed	<ul style="list-style-type: none"> • Beltway power outfeed connector with cover that matches receptacle color 	+\$29	Specify with <i>beltway power outfeed connector</i> .
Related Products	<ul style="list-style-type: none"> • Internode below-worksurface mounting bracket 		▶ Page 119

Specification Information

Harness Length	Line	Style Number	U.S. Base Price	Style Number	U.S. Base Price
----------------	------	--------------	-----------------	--------------	-----------------

4-Circuit, 3+1

With System Ground				With Isolated Ground	
72"	Line 1	GFUT1S72X	\$229	GFUT1G72X	\$229
	Line 2	GFUT2S72X	\$229	GFUT2G72X	\$229
	Line 3	GFUT3S72X	\$229	GFUT3G72X	\$229
	Line 4	GFUT4S72X	\$229	GFUT4G72X	\$229

4-Circuit, 2+2

With System Ground				With Isolated Ground	
72"	Line 1	GFUT1S72Y	\$229	GFUT1G72Y	\$229
	Line 2	GFUT2S72Y	\$229	GFUT2G72Y	\$229
	Line 3	GFUT3S72Y	\$229	GFUT3G72Y	\$229
	Line 4	GFUT4S72Y	\$229	GFUT4G72Y	\$229

3-Circuit, Separate Neutrals

With System Ground				With Isolated Ground	
72"	Line 1	GFUT1S72Z	\$229	GFUT1G72Z	\$229
	Line 2	GFUT2S72Z	\$229	GFUT2G72Z	\$229
	Line 3	GFUT3S72Z	\$229	GFUT3G72Z	\$229



For Canadian Pricing
Multiply U.S. Price by the
Canadian price factor.
▶ See page 1 for details.

Internode Convenience Tri-Receptacles with Power Cord and Plug



Tip: This unit does not include clamp kit.

Standard Includes		Required to Specify
▶ Need help? Product details, page 40	<ul style="list-style-type: none"> Convenience tri-receptacle housing: plastic Three receptacles: black 96" power cord with grounded plug: black only 	1 Style number 2 Plastic color number for tri-receptacle housing ▶ See <i>Surface Materials</i> , page 130.

Related Products	
<ul style="list-style-type: none"> Internode above-worksurface clamp kit Internode below-worksurface mounting bracket 	▶ Page 119 ▶ Page 119

Specification Information				
Dimensions			Style Number	U.S. Price
D	W	H		
2¾"	5¼"	2½"	GFUTP96	\$117

Internode Convenience Communication Outlet Housing



Tip: This unit does not include clamp kit.

Standard Includes		Required to Specify
▶ Need help? Product details, page 41	<ul style="list-style-type: none"> Housing for customer-supplied modular furniture faceplates: plastic 	1 Style number 2 Plastic color number for housing ▶ See <i>Surface Materials</i> , page 130.

Related Products	
<ul style="list-style-type: none"> Internode above-worksurface clamp kit Internode below-worksurface mounting bracket 	▶ Page 119 ▶ Page 119

Specification Information				
Dimensions			Style Number	U.S. Price
D	W	H		
2¾"	5¼"	2½"	GFUCH	\$57



For Canadian Pricing
 Multiply U.S. Price by the
 Canadian price factor.
 ▶ See page 1 for details.

Internode Above-Worksurface Clamp Kit



Standard Includes	Required to Specify
<ul style="list-style-type: none"> ▶ Need help? Product details, page 41 • Pair of rail-mount pins: 6653 Solar Black plastic only 	Style number

Related Products	
• Internode convenience tri-receptacles with modular harness	▶ Page 117
• Internode convenience tri-receptacles with power cord and plug	▶ Page 118
• Internode communication convenience outlet housing	▶ Page 118

Specification Information	
• Style Number	• U.S. Price
GFUTMC	\$17

Internode Below-Worksurface Mounting Bracket



Tip: Mounting bracket supports convenience receptacles and communications outlet housing below the worksurface.

Tip: Each tri-receptacle, whether power or communications, should have its own mounting bracket for below-worksurface mounting applications.

Standard Includes	Required to Specify
<ul style="list-style-type: none"> ▶ Need help? Product details, page 41 • Mounting bracket: 4793 Solar Black only 	Style number

Related Products	
• Internode convenience tri-receptacles with modular harness	▶ Page 117
• Internode convenience tri-receptacles with power cord and plug	▶ Page 118
• Internode communication convenience outlet housing	▶ Page 118

Specification Information	
• Style Number	• U.S. Price
GFUTMB	\$12

For Canadian Pricing
Multiply U.S. Price by the Canadian price factor.
▶ See page 1 for details.

Internode Cord and Cable Manager

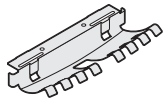

Standard Includes	Required to Specify
<ul style="list-style-type: none"> ▶ Need help? Product details, page 41 • Cord and cable manager: 6653 Solar Black only • Package of four • Mounting hardware package 	Style number

Related Products	
<ul style="list-style-type: none"> • Internode power modules 	▶ Page 110

Specification Information				
• Dimensions			• Style	• U.S.
D	W	H	Number	Price
3½"	10"	1¾"	GFUCCM	\$117
·	·	·	·	·

Internode Harness Clips



Standard Includes	Required to Specify
<ul style="list-style-type: none"> ▶ Need help? Product details, page 41 • Package of 25 harness clips with screws: black only 	Style number

Specification Information		
• Diameter	• Style	• U.S.
·	Number	Price
1¼"	GFUCMC	\$39
·	·	·



For Canadian Pricing
 Multiply U.S. Price by the
 Canadian price factor.
 ▶ See page 1 for details.

Standard Shelf Lights

Tip: Daisy chaining is not allowed in Chicago. Local electrical codes vary, so you should consult a qualified electrical contractor or engineer for proper installation of all electrical equipment.

Tip: Because shelf lights are usually recessed, black is the standard paint color. Paint colors other than black have an upcharge.

Tip: If an optional paint color is selected for the housing, the electrical switches and end caps will remain black plastic.

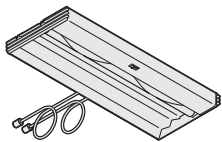
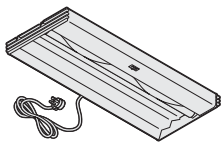

Tip: Remember to order a daisy chain starter cord.

▶ See *Related Products* on next page.



For Canadian Pricing

Multiply U.S. Price by the Canadian price factor.

▶ See page 1 for details.

	Standard Includes	Required to Specify
▶ Need help? Product details, page 44	<ul style="list-style-type: none"> Light housing with centered on-off switch: black paint End cap cord managers: black plastic only Cords: <ul style="list-style-type: none"> — 9' cord with three-prong plug at 45° angle: black plastic only — One 30" and one 48" cord with modular connectors for daisy chaining: black plastic only Contrast sleeve around lamp Faceted reflector: white only T8 3500K lamp Ballast Universal mounting hardware package Daisy chain starter cord, if selected: black plastic only (order separately) 	<ol style="list-style-type: none"> Style number Paint color number, if other than black (see options below) Options, if selected (see below) <p>▶ See <i>Surface Materials</i>, page 130</p>

	Options	U.S. Price	Required to Specify
Surface Materials	<ul style="list-style-type: none"> Painted light housing other than black 	+\$24	Specify paint color number for housing.
Bracket Option	<ul style="list-style-type: none"> Competitive mounting package Flush mounting package 	No cost No cost	Specify <i>with competitive mounting package</i> . Specify <i>with flush mounting package</i> and paint color number for end cap covers.

Specification Information

Dimensions	Lamp	Style	U.S.
D W H	Wattage	Number	Base Price
.....

Electronic High-Power-Factor Ballast

9 1/4"	25"	1 3/4"	17 watts	LSM24K	\$407
9 1/4"	37"	1 3/4"	25 watts	LSM36K	\$432
9 1/4"	49"	1 3/4"	32 watts	LSM48K	\$467

With Chicago Cord Including Circuit Breaker

9 1/4"	25"	1 3/4"	17 watts	LSM24KC	\$470
9 1/4"	37"	1 3/4"	25 watts	LSM36KC	\$495
9 1/4"	49"	1 3/4"	32 watts	LSM48KC	\$530

With Daisy Chain Cords

9 1/4"	25"	1 3/4"	17 watts	LSM24KD	\$442
9 1/4"	37"	1 3/4"	25 watts	LSM36KD	\$467
9 1/4"	49"	1 3/4"	32 watts	LSM48KD	\$502

▶ **Specification Information, continued on next page**

► **Specification Information, continued from previous page**

Related Products

Quantity in Package	Length	Style Number	U.S. Price
---------------------	--------	--------------	------------

Daisy Chain Starter Cord

1	78"	LS1FSC	\$ 56
6	78"	LS6FSC	\$336

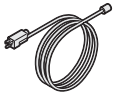

Tip: Use with Standard shelf light only. Do not order with Utility2.

Specifying



For Canadian Pricing
 Multiply U.S. Price by the Canadian price factor.
 ► See page 1 for details.

Utility2 Shelf Lights

Tip: Daisy chaining is not allowed in Chicago. Local electrical codes vary, so you should consult a qualified electrical contractor or engineer for proper installation of all electrical equipment.

Tip: Specification guidelines can be found on the next page.

Tip: Cord on stand alone light has right-hand exit. Cord on daisy chain light has off center exit.

Tip: Because shelf lights are usually recessed, black is the standard paint color. Paint colors other than black have an upcharge.

Tip: If an optional paint color is selected for the housing, the electrical switches and end caps will remain black plastic.

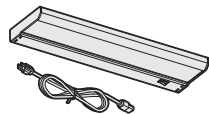
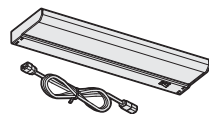
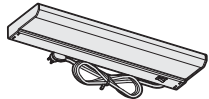

Tip: Minimum of two fixtures for daisy chaining and maximum of 10.

Tip: When ordering starter light do not order a daisy chain starter cord.

 **For Canadian Pricing**
Multiply U.S. Price by the Canadian price factor.
▶ See page 1 for details.

Standard Includes		Required to Specify
▶ Need help? Product details, page 44	<ul style="list-style-type: none"> Light housing with right-hand on-off switch: black paint End cap cord managers: black plastic only Cords: <ul style="list-style-type: none"> – 9' cord with three-prong plug on stand alone lights and daisy chain starter lights, if selected – 78" jumper cord on daisy chain lights, if selected Prismatic lens Angled reflector: silver only T8 3500K lamp Ballast Universal and flush mounting hardware package 	1 Style number 2 Paint color number, if other than black (see options below) 3 Options, if selected (see below) ▶ See <i>Surface Materials</i> , page 130.

Options	U.S. Price	Required to Specify
Surface Materials • Painted light housing other than black	+\$24	Specify paint color number for housing.
Lens • Batwing lens	+\$32	Specify with batwing lens.

Specification Information					
Dimensions	Lamp Wattage	Style Number	U.S. Base Price		
D	W	H			
67/8"	25"	15/8"	17 watts	LSB24K2	\$269
67/8"	37"	15/8"	25 watts	LSB36K2	\$318
67/8"	49"	15/8"	32 watts	LSB48K2	\$353

Electronic High-Power-Factor Ballast

67/8"	25"	15/8"	17 watts	LSB24K2	\$269
67/8"	37"	15/8"	25 watts	LSB36K2	\$318
67/8"	49"	15/8"	32 watts	LSB48K2	\$353

With Chicago Cord Including Circuit Breaker

67/8"	25"	15/8"	17 watts	LSB24KC2	\$332
67/8"	37"	15/8"	25 watts	LSB36KC2	\$381
67/8"	49"	15/8"	32 watts	LSB48KC2	\$416

Daisy Chain Light with 78" Jumper Cord

67/8"	25"	15/8"	17 watts	LSB24KD2	\$304
67/8"	37"	15/8"	25 watts	LSB36KD2	\$353
67/8"	49"	15/8"	32 watts	LSB48KD2	\$388

Daisy Chain Starter Light with 9' Starter Cord

67/8"	25"	15/8"	17 watts	LSB24KS2	\$304
67/8"	37"	15/8"	25 watts	LSB36KS2	\$353
67/8"	49"	15/8"	32 watts	LSB48KS2	\$269

▶ **Specification Information, continued on next page**

► **Specification Information, continued from previous page**

Specification Information

Dimensions			Lamp	Style	U.S.
D	W	H	Wattage	Number	Base Price

Electronic Normal-Power-Factor Ballast

67/8"	25"	15/8"	17 watts	LSB24M2	\$192
67/8"	37"	15/8"	25 watts	LSB36M2	\$241
67/8"	49"	15/8"	32 watts	LSB48M2	\$276

With Chicago Cord Including Circuit Breaker

67/8"	25"	15/8"	17 watts	LSB24MC2	\$255
67/8"	37"	15/8"	25 watts	LSB36MC2	\$304
67/8"	49"	15/8"	32 watts	LSB48MC2	\$339

Daisy Chain Light with 78" Jumper Cord

67/8"	25"	15/8"	17 watts	LSB24MD2	\$227
67/8"	37"	15/8"	25 watts	LSB36MD2	\$276
67/8"	49"	15/8"	32 watts	LSB48MD2	\$311

Daisy Chain Starter Light with 9' Starter Cord

67/8"	25"	15/8"	17 watts	LSB24MS2	\$227
67/8"	37"	15/8"	25 watts	LSB36MS2	\$276
67/8"	49"	15/8"	32 watts	LSB48MS2	\$311

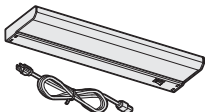
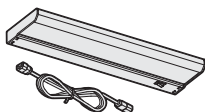
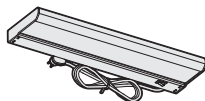

Tip: Minimum of two fixtures for daisy chaining and maximum of 10.

Tip: When ordering starter light do not order a daisy chain starter cord.

Specification Guidelines

Application	Requirement
2 lights	1 starter light fixture and 1 daisy chain light with jumper cord fixtures
3 lights	1 starter light fixture and 2 daisy chain light with jumper cord fixtures
4 lights	1 starter light fixture and 3 daisy chain light with jumper cord fixtures
5 lights	1 starter light fixture and 4 daisy chain light with jumper cord fixtures
6 lights	1 starter light fixture and 5 daisy chain light with jumper cord fixtures
7 lights	1 starter light fixture and 6 daisy chain light with jumper cord fixtures
8 lights	1 starter light fixture and 7 daisy chain light with jumper cord fixtures
9 lights	1 starter light fixture and 8 daisy chain light with jumper cord fixtures
10 lights	1 starter light fixture and 9 daisy chain light with jumper cord fixtures

 **For Canadian Pricing**
 Multiply U.S. Price by the Canadian price factor.
 ► See page 1 for details.

LED Shelf Lights

Tip: Daisy chaining is not allowed in Chicago. Local electrical codes vary, so you should consult a qualified electrical contractor or engineer for proper installation of all electrical equipment.

Tip: Maximum number of lights that can be daisy chained is three lights.

Standard Includes		Required to Specify
<ul style="list-style-type: none"> ▶ Need help? Product details, page 46 	<ul style="list-style-type: none"> Aluminum extrusion with plastic cover Power supply with cord Soft touch switch Thin profile accommodates recessed and low profile flush mounting Ultra energy efficient LED light source Universal magnetic mounting Polycarbonate matte film diffuser Continuous dimming 	<ul style="list-style-type: none"> 1 Style number 2 Plastic color number for cover: <ul style="list-style-type: none"> 6000 Black 6009 Arctic White 3 Options, if selected (see below)

Options	U.S. Price	Required to Specify
Mounting <ul style="list-style-type: none"> Fastener kit for use with wood or aluminum shelf 	+\$8	Specify with fastener kit.

Specification Information					
Dimensions			Lamp Wattage	Style Number	U.S. Base Price
D	W	H			

LED Standard Light

2 1/2"	18"	1/2"	11 watts	LSL18	\$336
:	:	:	:	:	:

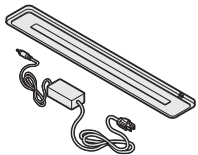

Tip: LED standard light comes with a 9' 15 watt power supply.

LED Daisy Chain Starter Light

2 1/2"	18"	1/2"	11 watts	LSL18YA	\$360
:	:	:	:	:	:

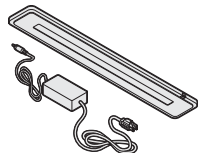

Tip: Daisy chain starter light comes with a 60 watt power supply that will support up to three lights in series (11' cord, 6' from power supply to power outlet, 5' from power supply to fixture). Does not include daisy chain cords.

LED Daisy Chain Secondary Light

2 1/2"	18"	1/2"	11 watts	LSL18YB	\$330
:	:	:	:	:	:

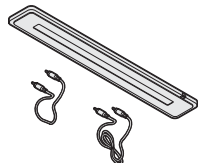

Tip: Daisy chain secondary light does not come with a power supply. Daisy chain cord package (8" and 30") comes standard with each secondary light.

Standard Includes		Required to Specify
<ul style="list-style-type: none"> ▶ Need help? Product details, page 48 	<ul style="list-style-type: none"> • Housing: 6009 Arctic White plastic only • Fixture and stanchions: paint • Power supply with 12' cordage (6' from power supply to power outlet, 6' from power supply to fixture) • Soft touch switch • Ultra energy efficient LED light source • Polycarbonate matte film diffuser • Continuous dimming 	<ul style="list-style-type: none"> 1 Style number 2 Paint color number for fixture and stanchions: <ul style="list-style-type: none"> 4231 Arctic White 4710 Low Gloss Black 4799 Platinum Metallic

Related Products	
<ul style="list-style-type: none"> • c:scape desk • FrameOne bench • Details SOTO rail • Impact • Technology zone integral rail • Worksurfaces • Campfire Big Table 	<ul style="list-style-type: none"> ▶ See <i>c:scape Specification Guide</i>. ▶ See <i>FrameOne Specification Guide</i>. ▶ See <i>Details SpecGuide</i>. ▶ See <i>Wood Casegoods and Tables Specification Guide</i>. ▶ See <i>Elective Elements Specification Guide</i>. ▶ See <i>Answer Solutions Specification Guide</i>. ▶ See <i>Turnstone Specification Guide</i>.

Specification Information

Dimensions			Lamp	Style	U.S.
D	W	H	Wattage	Number	Price

Rail-Mounted LED Personal Task Light

6"	30"	17"	14 watts	LPTL30	\$590
----	-----	-----	----------	---------------	-------

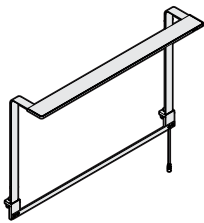

Non Rail-Mounted LED Personal Task Light

6"	30"	17"	14 watts	LPTL30NR	\$590
----	-----	-----	----------	-----------------	-------

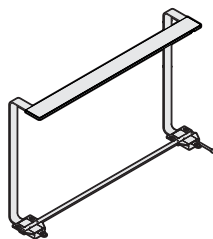

Tip: Non rail-mounted LED personal task lights will not work on worksurfaces with knife edge that is longer than 1 1/4", or with modesty panels or modesty screens closer than 6" from the back edge.



For Canadian Pricing
 Multiply U.S. Price by the Canadian price factor.
 ▶ See page 1 for details.



Surface Materials

Surface Materials	130
Color Coordination Lists	136
Ellipse Open Line Laminate Edge Coordination Matrix	138
Universal Storage Edge Coordination Matrix	139
Surface Materials Application Topics	140

Surface Materials

This listing includes all the surface material choices that are available for the products in this specification guide.

Resources

For more information about surface materials, refer to the following resources:

Additional surface materials specification tools are available to assist you in the specification process—the Surface Materials Binders.

The global surface materials palette is a core collection of finishes that is available across multiple geographies (Americas/EMEA – Europe, Middle East, and Africa/APAC – Asia Pacific) and on global product lines, where applicable. For a list of finishes included in the offering, see the Surface Materials Reference Manual. Additional details, like product approvals by geography and finish number conversions, can also be found in the Surface Materials Reference Manual or see steelcase.com/surfacematerials.

Surface Materials Binders

- Surface Materials Reference Manual
- A complete set of swatch cards for hard surfaces, vertical surface fabrics, and seating upholstery

Paint

- Applies to:
- Legs
 - Power beam
 - Modesty panel
 - Table column and base
 - Shelf lights
 - Screen supports
 - Universal Storage
 - Overhead cabinet

Steelcase Surfaces

Price Group 1

Smooth Paint

- 4242 Milk

Textured Paint

- 7207 Black
7225 Sand
7230 Basalt
7236 Fog **E**
7237 Slate **E**
7238 Fieldstone
7239 Midnight
7241 Arctic White
7243 Seagull
7278 Dark Bronze

Price Group 2

Smooth Metallic Paint

- 4743 Mineral Metallic
4744 Pearl Metallic
4750 Champagne Metallic
4752 Steel Metallic **E**
4788 Gold Dust Metallic **E**
4798 Sterling Metallic
4799 Platinum Metallic
4803 Near Black Metallic

Textured Metallic Paint

- 7245 Carbon Metallic
7246 Midnight Metallic

Select Surfaces

Price Group 3

Accent paint

Accent paints allow you to choose from a pre-matched color palette of trend driven colors that are available without the PerfectMatch registration fee. Refer to the *Surface Materials Reference Manual* for more information about this program.

Custom Surfaces

Price Group 3

PerfectMatch

PerfectMatch is a service that allows you to create your own paint color. Refer to the *Surface Materials Reference Manual* for more information about this program.

Laminate

Applies to:

- Worksurfaces
- Universal Storage tops

Steelcase Surfaces

Fiber

- 2850 Vanadium Fiber
2851 Rhyme Fiber **E**
2852 Tungsten Fiber
2854 Vellum Fiber
2859 Novell Fiber
2860 Granite Fiber
2861 Coconut Fiber
2862 Stucco Fiber

Micro

- 2920 Marl Micro
2921 Gypsum Micro
2922 Clay Micro
2923 Shadow Micro **E**

Patina

- 2870 Blonde Bronze Patina
2871 Blackened Bronze Patina
2873 Instant Iron Patina

Solid

- 2722 Cream **E**
2730 Arctic White
2746 Black
2759 Warm White **E**
2811 Mist **E**
2883 Seagull
2884 Milk
2885 Dune

Speckle

- 2820 Coffee Speckle
2822 Woodrose Speckle **E**
2823 Driftwood Speckle
2824 Smoke Speckle
2825 Vanadium Speckle

Note: Some wood veneer finishes and woodgrain laminates share the same name. Because of the difference in materials, veneers and laminates of the same name are not an exact match but do coordinate with each other.

Woodgrain

- 2406 Clear Cherry
2409 Clear Maple
2410 Graphite Walnut
2412 Natural Cherry
2422 Medium Cherry
2511 Winter on Maple
2538 Clear Walnut
2539 Warm Oak **E**
2592 Blonde on Maple
2714 Natural Walnut
2772 Medium Mahogany on Walnut **E**
2HAK Clear Oak
2HAT Acacia

Applies to:

- Universal Storage tops

Turnstone Laminate Collection

A selection of laminates and edge bands in this collection are available on Steelcase brand products. This collection is available with standard leadtimes and supported like standard laminates to help make ordering easy. Please see the Turnstone section of village.steelcase.com for swatching information.

- 2535 Virginia Walnut
2536 Blackwood
2612 Marbled Maple
2614 Chocolate Walnut
2615 Marbled Cherry

Tip: Available on Universal Storage Square edge laminate tops only.

Tip: Grain direction of woodgrain laminates and Turnstone laminates is always parallel to the front edge.

Custom Surfaces

Open Line Laminate (OLL)

This service allows you to order non-standard laminate at an additional processing fee upcharge of \$67 U.S. per worksurface or top, plus the cost of the laminate. Edge color for Open Line laminate must be determined by the dealer and customer before orders can be entered.

When processing orders for Open Line laminates on Universal Storage tops, specify 2900 in the laminate finish field and enter the OLL manufacturer information. Enter the required edge finish as you would a standard laminate.

► See *Open Line Laminate Edge Coordination Matrix*, page 138.

Tip: Standard laminates being used in the Open Line Laminate Program to obtain a different edge detail will be charged the Open Line laminate upcharge; however, no additional charges for the laminate will be applied.

Laminate Approval and Material Requirements

To confirm whether a particular laminate has already been tested for use on a specific Steelcase product, or to determine material square foot requirements:

- Visit www.steelcase.com

For additional information, refer to the *Steelcase Surface Materials Reference Manual*.

E = Established

Wood

Applies to:

- Universal Storage tops and fronts

Steelcase carefully selects veneer and solid wood for consistent color and grain structure. Wood is a natural material and variations will occur in color, grain and texture. These variations are part of the inherent natural beauty of wood and are not considered defects.

All wood products will darken with age and exposure to ultraviolet light. This is especially apparent with cherry and maple veneer. We recommend that desk accessories be rearranged periodically to ensure even aging of wood surfaces.

When storing your wood furniture, please follow the following guidelines:

- Do not store products in trailers
- Store products in areas that simulate office temperatures (60°F to 90°F)
- Store products in areas that maintain constant, office-like humidity levels
- Keep product away from light. Cover products to make sure they are not exposed to light.

Steelcase Surfaces

Veneer

Veneers are matched for proper balance and consistency. Veneers are available flat cut or quarter cut, except for Oak, which is rift cut. Refer to the *Surface Materials Reference Manual* for descriptions of each cut.

Open-pore finish is a medium gloss finish that leaves the wood grain texture visible to the eye and distinguishable to the touch.

Flat-cut open-pore finish choices

3062	FC/OP Graphite Walnut
3402	FC/OP Clear Cherry (Aged)
3412	FC/OP Natural Cherry E
3422	FC/OP Medium Cherry
3522	FC/OP Clear Maple*
3572	FC/OP Amber on Maple E
3592	FC/OP Blonde on Maple
3702	FC/OP Clear Walnut
3712	FC/OP Natural Walnut
3722	FC/OP Dark Mahogany on Walnut
3752	FC/OP Medium Walnut
3762	FC/OP Dark Walnut
3772	FC/OP Medium Mahogany on Walnut

Quarter-cut open-pore finish choices

3222	QC/OP Clear Maple*
3272	QC/OP Amber on Maple E
3292	QC/OP Blonde on Maple
3302	QC/OP Clear Walnut
3312	QC/OP Natural Walnut
3322	QC/OP Dark Mahogany on Walnut
3352	QC/OP Medium Walnut
3362	QC/OP Dark Walnut
3372	QC/OP Medium Mahogany on Walnut
3382	QC/OP Graphite Walnut

Rift-cut open-pore finish choices

3602	RC/OP Desert Oak
3612	RC/OP Warm Oak E
3692	RC/OP Espresso Oak

Full-fill finish is a medium-gloss finish that completely fills the grain texture, yet allows the grain pattern to be seen. The wood has a lustrous, satiny look, and it is smooth to the touch. This finish is available on the wood worksurface or field-installed top only.

Flat-cut full-fill finish choices

3064	FC/FF Graphite Walnut
3404	FC/FF Clear Cherry (Aged)
3414	FC/FF Natural Cherry E
3424	FC/FF Medium Cherry
3524	FC/FF Clear Maple*
3544	FC/FF Blonde on Maple
3574	FC/FF Amber on Maple E
3704	FC/FF Clear Walnut
3714	FC/FF Natural Walnut
3724	FC/FF Dark Mahogany on Walnut
3754	FC/FF Medium Walnut
3764	FC/FF Dark Walnut
3774	FC/FF Medium Mahogany on Walnut

Quarter-cut full-fill finish choices

3224	QC/FF Clear Maple*
3274	QC/FF Amber on Maple E
3294	QC/FF Blonde on Maple
3304	QC/FF Clear Walnut
3314	QC/FF Natural Walnut
3324	QC/FF Dark Mahogany on Walnut
3354	QC/FF Medium Walnut
3364	QC/FF Dark Walnut
3374	QC/FF Medium Mahogany on Walnut
3384	QC/FF Graphite Walnut

Rift-cut full-fill finish choices

3604	RC/FF Desert Oak
3614	RC/FF Warm Oak E
3694	RC/FF Espresso Oak

**To ensure an understanding of the color ranges and characteristic variations of natural veneer, a sign-off sheet is required prior to orders being accepted for this clear-coat finish. The sign-off sheet is available through Steelcase advertising stock. Form number 05-0001370.*

Steelcase Surfaces

Composite Veneer

Composite veneers are an engineered wood intended to create specific grain patterns and characteristics. They are pre-stained and finished with Steelcase's Clarity water-borne UV topcoat, which protects the environment while providing durability and clarity. Only open-pore finishes are available on composite wood. Composite veneer and matching edge bands are available on most Steelcase brand products. Composites, for use as a solid nosing substitute, are not available. Steelcase does not recommend mixing composite veneers with natural solid nosings because composite and natural wood grain and color matching are rarely compatible. Composite veneers are Graded-In as Wood Group 1 pricing.

Flat-cut open-pore finish choices

3JDX	FC/OP Oak Composite
3JFX	FC/OP Maple Composite
3JHX	FC/OP Cherry Composite
3JJX	FC/OP Walnut Composite

Quarter-cut open-pore finish choices

3HGX	QC/OP Oak Composite
3JEX	QC/OP Maple Composite
3JGX	QC/OP Cherry Composite

Note: To understand more about composite ordering, leadtimes, and pricing, please consult the composite sign-off sheet available through Steelcase advertising stock, form number 14-0000141. A sign-off sheet is required prior to orders being accepted for composite projects.

Custom Surfaces

Customiz stain is a service that allows you to create your own stain colors and finishes on standard veneer. Customiz stain color is available on all product lines that offer wood veneer.

A \$500 stain-matching fee applies on CUSTOMIZ requests (Exception: The \$500 fee does not apply on matches to Coalesse standard finishes or for a low-gloss finish request on a standard color). The \$500 fee covers the cost of formulating the Customiz color finish and applies regardless of whether or not an order for product is placed.

In addition, an approval form must be signed to indicate customer acceptance of Customiz match. A \$1,500 initiation fee will be charged prior to first order entry. This initiation fee activates the finish for unlimited use on any Steelcase product for an 18 month time period. After the 18 month time period has lapsed, the Customiz finish may be reactivated for another 18 months for a \$1,000 fee at any point within five years after the \$1,500 initiation fee was paid. If the finish is not reactivated within five years after the \$1,500 initiation fee was paid, the finish will be culled and the customer will need to pay the \$1,500 initiation fee again. All style number related Customiz charges products are no cost as of April 2014. The matching and initiation fees are not discountable.

Customiz stain takes 10 days to formulate. Consult the *Surface Materials Reference Manual* for more information. Custom veneers are also available and must be quoted by Steelcase specials group. Customiz stain on custom veneers takes 2 to 4 weeks to formulate.

Requirements and information on ordering a Customiz stain color are found in the *Surface Materials Reference Manual*.

E = Established

Plastic

Steelcase Surfaces

Tip: Not every plastic component is available in every plastic color. Worksurface color determines the color of many plastic components. See page 137 for an overview of the plastic colors that are available for each component.

Applies to:

- Return filler

- 6000 Black
- 6001 Coffee
- 6612 Grey V2 **E**
- 6617 Warm Brown V2 **E**
- 6631 Cream
- 6635 Dawn **E**
- 6636 Mist
- 6654 Sand
- 6655 Warm White

Applies to:

- Internode

- 6000 Black
- 6009 Arctic White
- 6249 Platinum Solid
- 6651 Tungsten **E**
- 6652 Titanium **E**
- 6653 Solar Black **E**
- 6654 Sand
- 6681 Grotto

Applies to:

- Leg trim strip
- Glide covers

- 6000 Black
- 6002 Graphite **E**
- 6655 Warm White
- 6681 Grotto

Applies to:

- 1 mm square edge profile on Universal Storage laminate tops

- 6000 Black
- 6001 Coffee
- 6009 Arctic White
- 6034 Natural Cherry
- 6035 Medium Cherry
- 6037 Winter on Maple
- 6038 Blonde on Maple
- 6041 Natural Walnut
- 6045 Medium Mahogany on Walnut
- 6052 Milk
- 6053 Seagull
- 6213 Acacia
- 6219 Clear Oak
- 6231 Graphite Walnut
- 6234 Clear Cherry
- 6237 Clear Maple
- 6242 Virginia Walnut
- 6243 Blackwood
- 6245 Clear Walnut
- 6246 Walnut Oak **E**
- 6249 Platinum Solid
- 6615 Grey V5
- 6619 Ice **E**
- 6631 Cream
- 6635 Dawn **E**
- 6636 Mist
- 6654 Sand
- 6655 Warm White
- 6676 Marbled Maple
- 6677 Chocolate Walnut
- 6678 Marbled Cherry
- 6694 Slate
- 6695 Midnight
- 6697 Fog
- 6698 Fieldstone

Note: Light color plastic edges are susceptible to degradation due to normal wear and tear. Staining (e.g., ball point pen or clothing dyes such as blue jeans) and dirt effects are more pronounced in light colors and are not considered defects.

Vertical Surface Fabric

Applies to:

- Screens

Steelcase Surfaces

Price Group 1

Abacus **E**

- P122 Entasis
- P123 Portico
- P124 Opus
- P125 Cusp
- P126 Artifact
- P129 Atlas

Acadia **E**

- G031 Tin
- G033 Iron
- G039 Silica

Alloy

- P525 Polar
- P526 Skim
- P527 Bubbly
- P528 Tern
- P529 Shore
- P530 Asti
- P531 Silver
- P532 Oxide
- P533 Element
- P534 Construct
- P535 Currency
- P536 Iron

Boccie

- P200 New Rice
- P201 New Almond
- P202 New Nutmeg
- P203 New Camel
- P204 New Opal
- P205 New Mist
- P206 New Plum
- P207 New Lichen
- P208 New Spearmint
- P209 New Sky

Buzz2

- 5F01 Camel **E**
- 5F03 Tomato
- 5F04 Red **E**
- 5F05 Burgundy
- 5F06 Sky **E**
- 5F07 Blue
- 5F08 Navy
- 5F10 Grape **E**
- 5F11 Eggplant **E**
- 5F15 Stone
- 5F16 Grey
- 5F17 Black
- 5G50 Dunegrass
- 5G51 Sable
- 5G52 Barley
- 5G53 Sunrise
- 5G54 Carrot
- 5G55 Pumpkin
- 5G56 Timber
- 5G57 Rouge
- 5G58 Chocolate
- 5G59 Meadow
- 5G60 Ivy
- 5G61 Cyan
- 5G62 Atlantic
- 5G63 Crocus
- 5G64 Alpine
- 5G65 Tornado

Charm

- P505 Shell
- P506 Mimosa
- P507 Birch
- P508 Sparkle
- P509 Ginkgo
- P510 Debut
- P511 Clover
- P512 Spicy
- P513 Twilight

Embrasure **E**

- P140 Colonnade
- P141 Rotunda
- P143 Baluster

Lapel

- P409 Cement
- P410 Pebble
- P411 Beech
- P412 Dune
- P413 Grain
- P414 Sprout
- P415 Misty Blue
- P416 Maple
- P417 Slate

Optic

- P540 Hazel
- P541 Twinkle
- P542 Orion
- P543 Seaglass
- P544 Shine
- P545 Halo
- P546 Whiskey
- P547 Bath
- P548 Whisper
- P549 Breezy
- P550 Wry
- P551 Glimmer

Pianista

- P420 Sand
- P421 Mist
- P422 Rain
- P423 Natural
- P424 Café
- P425 Denim
- P426 Carbon
- P427 Stone
- P428 Flax
- P429 Oat
- P430 Wheat
- P431 Maize

Rhythm

- P555 Allegro
- P556 Tempo
- P557 Refrain
- P558 Pitch
- P559 Harmony
- P560 Melody
- P561 Stanza
- P562 Opus

Tinsel

- P516 Lit
- P517 Ego
- P518 Fizz
- P519 Muse
- P520 Depth
- P521 Bliss
- P522 Grow
- P523 Dolce

Price Group 2

Amiranté **E**

- 5664 Mink
- 5665 Ivory
- 5666 Silver Frost
- 5677 Moonglo
- 5679 Woodbine

Ashanti Reverse **E**

- 5638 Mink
- 5648 Moonglo
- 5650 Woodbine
- 5654 Quince

Bariolage

- G200 New Etude
- G201 New Andante
- G202 New Cantata
- G203 New Adagio
- G204 New Melody
- G205 New Ballata
- G206 New Sonata

Bouquet **E**

- P165 Hosta
- P166 Dundee
- P169 Argenta
- P170 Hoya
- P173 Camomile

E = Established

Cogent: Geode Seating **E**

5S47 Coal
5S49 Cobalt
5S50 Ink

Cogent: Geode Vertical **E**

5S32 Canyon
5S35 Slate
5S36 Cement
5S38 Oyster
5S41 Sesame

Flip: Orbit

5F85 Mud Pie
5F86 Hummus
5F87 Petoskey
5F88 Pluto
5F89 Papyrus
5F91 Blizzard
5F92 Briquette

Flip: Plain Jane

5F70 Mud Pie
5F71 Hummus
5F72 Petoskey
5F73 Pluto
5F74 Papyrus
5F94 Blizzard
5F95 Briquette

Flip: TexHex

5F75 Mud Pie
5F76 Hummus
5F77 Petoskey
5F78 Pluto
5F79 Papyrus
5F97 Blizzard
5F98 Briquette

Fresco

G001 Sandrift
G002 Mistiblu
G003 Faon
G006 Chamoline
G007 Grapenut
G017 Flint

Milano **E**

N001 Oyster
N002 Delft
N003 Woodland
N004 Sunshadow
N005 Olivine
N012 Teakwood

Regatta **E**

D011 Licorice
5335 Warm Brown V1
5338 Tan V1

Select Surfaces

For information on products within Select Surfaces, including accent paints and fabrics from Designtex, Gabriel, Kvadrat, and Pollack, please refer to the *Surface Materials Reference Manual* or visit Steelcase.com/selectsurfaces.

Seating Upholstery

Applies to:
• Universal mobile pedestal cushion top

Steelcase Surfaces**Price Group 1****Buzz2**

5F01 Camel **E**
5F03 Tomato
5F04 Red **E**
5F05 Burgundy
5F06 Sky **E**
5F07 Blue
5F08 Navy
5F10 Grape **E**
5F11 Eggplant **E**
5F15 Stone
5F16 Grey
5F17 Black
5G50 Dunegrass
5G51 Sable
5G52 Barley
5G53 Sunrise
5G54 Carrot
5G55 Pumpkin
5G56 Timber
5G57 Rouge
5G58 Chocolate
5G59 Meadow
5G60 Ivy
5G61 Cyan
5G62 Atlantic
5G63 Crocus
5G64 Alpine
5G65 Tornado

Jacks **E**

5B61 Taupe
5B63 Camel
5B64 Pewter
5B70 Midnight

Link

5A20 Burgundy
5A23 Green
5A24 Blue
5A25 Navy
5A26 Purple
5A27 Black
5A28 Ocean
5A30 Chamole

Playground **E**

5F28 Claret
5F29 Chile
5F30 Amber
5F31 Nut
5F32 Blade
5F33 Stone
5F34 Sky
5F35 Navy
5F36 Huckleberry
5F37 Charcoal

Price Group 2**Chainmail**

5550 Cotton
5551 Space
5552 Silver Dollar
5553 Volcano
5554 Orange Crush
5555 Tricycle
5556 Geranium
5557 Banana
5558 Margarita
5559 Lagoon

Cogent: Connect

5S15 Coconut
5S16 Turmeric
5S17 Tangerine
5S18 Scarlet
5S19 Concord
5S20 Maya Blue
5S21 Blue Jay
5S23 Wasabi
5S24 Nickel
5S25 Graphite
5S26 Licorice
5S27 Malt
5S28 Root Beer
5S93 Blueprint
5S94 Lizard
5S95 Sailor
5S96 Quicksilver
5S97 Nugget
5S98 Canary
5S99 Lipstick
5SD0 Royal Blue

Cogent: Geode Seating **E**

5S47 Coal
5S49 Cobalt
5S50 Ink

Cogent: Geode Vertical **E**

5S32 Canyon
5S35 Slate
5S36 Cement
5S38 Oyster
5S41 Sesame

Cogent: Trails

5S29 Bronzite
5S85 Agate
5S86 Lapis
5S87 Malachite
5S88 Quartz
5S90 Tiger Eye
5S91 Travertine
5S92 Topaz

Crosswalk **E**

5F48 Beech
5F49 Moon
5F50 Berry
5F51 Admiral Blue
5F52 Moss
5F53 Persimmon
5F54 Bittersweet
5F55 Midnight
5F56 Poppy

Nitelights

5F58 Hazelnut
5F59 Burgundy
5F60 Cherry
5F61 Earth
5F62 Shore
5F63 Moss
5F64 Sea
5F65 Regal Blue
5F66 Stone
5F67 Moon

Seating Vinyl **E**

5801 Topaz
5805 Foggy Night
5809 Black
5810 Forest
5812 Navy
5813 Currant
5814 Leaf
5815 Seaside
5817 Pebble
5818 Spice
5819 Thistle
5820 Coffee
5822 Iris

Spyder **E**

5B01 Foggy Night
5B04 Peri

Stand In

5621 Sleet
5622 Lunar
5623 Cyclone
5624 Eclipse
5625 Powder
5626 Chardonnay
5627 Graham
5628 Sediment
5629 Allspice
5630 Apple
5631 Lava
5632 Cayenne
5633 Plantain
5634 Parsley
5635 Scallion
5636 Atlantis
5691 Orca

Zoe2 **E**

5C90 Eggplant
5C91 Aloe
5C92 Fiddle
5C93 Patina
5C94 Peacock
5C95 Rain
5C96 Grey Flannel
5C97 Pebble
5C98 Cymbal
5C99 Fiesta

E = Established

Price Group 3

Gaja – C2C

- 5W40 Black
- 5W41 Pepper
- 5W42 Pearl Grey
- 5W43 Crimson
- 5W44 Ink
- 5W45 Night Blue
- 5W46 Petrol
- 5W47 Greige
- 5W48 Sepia
- 5W49 Umber
- 5W50 Java
- 5W51 Camellia Red
- 5W52 Emerald
- 5W53 Snow Pea
- 5W54 Olive
- 5W55 Light Blue
- 5W56 Maroon
- 5W57 Black Raspberry
- 5W58 Spruce
- 5W59 Apple Green
- 5W60 Deep Blue
- 5W61 Chili Pepper
- 5W62 Daffodil

Imperma

- TM01 Toffee
- TM02 Pigeon
- TM03 Fossil
- TM04 Poppyseed
- TM05 Auburn
- TM06 Cumin
- TM07 Marble
- TM08 Cliff
- TM09 Tarragon
- TM10 Pesto
- TM11 Wave
- TM12 Niagara
- TM13 Tuscan
- TM14 Peppercorn

Redeem

- TM50 Brick
- TM51 Yolk
- TM52 Cinnamon
- TM53 Daisy
- TM54 Pine
- TM55 Water
- TM56 Dill
- TM57 Lavender
- TM58 Mallard
- TM59 Caramel
- TM60 Greyhound
- TM61 Mocha
- TM62 Iceberg
- TM63 Chestnut
- TM64 Granite
- TM65 Cashmere
- TM66 Barnwood

Retrieve

- TM30 Kelly
- TM31 Lake
- TM32 Gala
- TM33 Papaya
- TM34 Dandelion
- TM35 Curry
- TM36 Lilac
- TM37 Submarine
- TM38 Driftwood
- TM39 Bistro
- TM40 Quarry
- TM41 Mohair
- TM42 Shadow
- TM43 Seal
- TM44 Chalk

Texel

- TM20 Angora
- TM21 Grist
- TM22 Galaxy
- TM23 Terracotta
- TM24 Nude
- TM25 Field
- TM26 Haze

Price Group 5

Bo Peep

- 5G66 Pita
- 5G67 Bone
- 5G68 Safari
- 5G69 Brown Sugar
- 5G70 Chocolate Chip
- 5G71 Candlelight
- 5G72 Honey Mustard
- 5G73 Marmalade
- 5G74 Picnic
- 5G75 Pinot
- 5G76 Bloom
- 5G77 Grapevine
- 5G78 Firefly
- 5G79 Artichoke
- 5G80 Serpent
- 5G81 Carolina
- 5G82 Blue Bonnet
- 5G83 Nautical
- 5G84 Gravel
- 5G85 Sharkskin
- 5G86 Kohl

Remix

- RE01 Rust
- RE02 Pumpkin
- RE03 Pebble
- RE04 Dark Chocolate
- RE05 Beige
- RE06 Linen Beige
- RE07 Hazelnut
- RE08 Concrete Grey
- RE09 Sky Blue
- RE10 Blue Jean
- RE11 Ivy Green
- RE12 Primavera Yellow
- RE13 Night Blue

Price Group 6

Brisa

- BR01 Black Onyx
- BR04 Truffle
- BR06 Ash
- BR07 Sage
- BR08 Celery
- BR09 Sterling Blue
- BR10 Night Navy
- BR11 Cambridge Blue
- BR12 Abyss
- BR13 Canyon
- BR14 Pompeian Red
- BR15 Salsa
- BR16 Cinnabar
- BR17 Aztec
- BR18 New Sand
- BR19 Cream
- BR20 White
- BR21 Moccasin
- BR22 Buckskin
- BR23 Prairie

Price Group 7

Steelcut Trio

- TR01 Mist Grey
- TR02 Stone Grey
- TR03 Cassonade Beige
- TR04 Nutmeg Beige
- TR05 Chocolate Blue
- TR06 Licorice Black
- TR07 Mustard Yellow
- TR08 Red Currant
- TR09 Raspberry Pink
- TR10 Myrtle Brown
- TR11 Ice Blue
- TR12 Electric Blue
- TR13 Peppermint Green
- TR14 Blue Jay Mix
- TR15 Brown Frost
- TR16 Lime Green

Leather Price Group

Steelcase Leather

- L107 Black
- L207 Mahogany
- L220 Soapstone
- L221 Rocky
- L500 Camel
- L503 Navy

Elmosoft Leather Price Group

Elmosoft Leather

- L110 Maritime Blue
- L111 Midnight Blue
- L112 Ebony
- L113 Gunmetal
- L114 Mica
- L115 Dove Grey
- L116 Plum Pleasure
- L122 Truffle
- L128 Red Birch
- L132 Violet
- L133 Espresso
- L134 Ruby
- L135 Scarlet
- L136 Claret
- L137 Cabernet
- L138 Bourbon
- L139 Cinder
- L140 Garnet
- L143 Pecan
- L144 Chamois
- L145 Palomino
- L146 Russet
- L147 Saddle
- L148 Goldstone
- L150 Ivory
- L151 White
- L709 Sugar
- L710 Lava
- L711 Parchment
- L712 Buff
- L713 Sand
- L714 Maize
- L715 Camel
- L716 Khaki
- L717 Cameo
- L718 Mushroom
- L719 Taupe
- L720 Fawn
- L721 Rock
- L722 Desert
- L723 Storm
- L724 Mist
- L725 Teal
- L726 Celadon
- L727 Egyptian Blue
- L728 Bright Blue
- L729 Aquarium
- L730 Hunter
- L731 Fern
- L732 Edamame
- L733 Moss
- L734 Key Lime
- L735 Creamsicle
- L736 Lemon
- L737 Sunshine
- L738 Drama
- L739 Byzantium
- L740 Dazzle
- L741 Fuchsia
- L742 Flamingo

E = Established

Select Surfaces

For information on products within Select Surfaces, including accent paints and fabrics from Designtex, Gabriel, Kvadrat, and Pollack, please refer to the *Surface Materials Reference Manual* or visit Steelcase.com/selectsurfaces.

Custom Surfaces

Price Group COM (Customer's Own Material)

Fabric Approval and Yardage

To confirm whether a particular COM material has already been tested for use on a specific Steelcase product or to determine actual yardage requirements:

- Visit www.steelcase.com

For additional information regarding Customer's Own Material, call 1.888.STEELCASE (1.888.783.3522) or send an e-mail to lineone@steelcase.com.

Color Coordination Lists

Ellipse Laminate Worksurface Coordination List

The colors of the plastic edge trim, grommet, and plastic T-mold are determined by the worksurface color you select. These colors are defaults and cannot be specified.

All laminates, except woodgrain laminates, will have solid color edging.

Woodgrain laminates will have a 1 mm woodgrain plastic edging and the grain of the edges will be horizontal. Plastic T-Mold will be solid color.

Note: Light color plastic edges are susceptible to degradation due to normal wear and tear. Staining (e.g., ball point pen or clothing dyes such as blue jeans) and dirt effects are more pronounced in light colors and are not considered defects.

Tip: To improve consistency, default edge colors are now identified by 6000-series numbers; actual colors and defaults have not changed. Because default edge colors are not actually entered when specifying products, no specification changes are required. (Previous specification guides used 2000-series numbers to describe default edge colors, while 6000-series numbers were used for customer-specified edge colors, even though the edges were identical.)

► See the *Surface Materials Reference Manual* for more details.

Laminate Color	Plastic 1 mm Edge Default Color	Plastic Grommet Default Color	Plastic T-Mold Default Color
Fiber			
2850 Vanadium Fiber	6654 Sand	6612 Grey Value 2 E	6654 Sand
2851 Rhyme Fiber E	6631 Cream	6608 Driftwood E	6631 Cream
2852 Tungsten Fiber	6636 Mist	6609 Smoke E	6636 Mist
2854 Vellum Fiber	6655 Warm White	6655 Warm White	6655 Warm White
2859 Novell Fiber	6001 Coffee	6001 Coffee	6001 Coffee
2860 Granite Fiber	6000 Black	6000 Black	6000 Black
2861 Coconut Fiber	6654 Sand	6654 Sand	6654 Sand
2862 Stucco Fiber	6053 Seagull	6053 Seagull	6053 Seagull
Micro			
2920 Marl Micro	6053 Seagull	6053 Seagull	6053 Seagull
2921 Gypsum Micro	6654 Sand	6654 Sand	6654 Sand
2922 Clay Micro	6654 Sand	6654 Sand	6654 Sand
2923 Shadow Micro E	6249 Platinum Solid	6249 Platinum Solid	6249 Platinum Solid
Patina			
2870 Blonde Bronze Patina	6654 Sand	6612 Grey Value 2 E	6654 Sand
2871 Blackened Bronze Patina	6615 Grey Value 5	6000 Black	6615 Grey Value 5
2873 Instant Iron Patina	6615 Grey Value 5	6000 Black	6615 Grey Value 5
Solid			
2722 Cream E	6631 Cream	6608 Driftwood	6631 Cream
2730 Arctic White	6697 Fog	6609 Smoke E	6697 Fog
2746 Black	6000 Black	6000 Black	6000 Black
2759 Warm White E	6655 Warm White	6655 Warm White	6655 Warm White
2811 Mist E	6636 Mist	6609 Smoke E	6636 Mist
2883 Seagull	6053 Seagull	6053 Seagull	6053 Seagull
2884 Milk	6052 Milk	6052 Milk	6052 Milk
2885 Dune	6654 Sand	6654 Sand	6654 Sand
Speckle			
2820 Coffee Speckle	6631 Cream	6001 Coffee	6001 Coffee
2822 Woodrose Speckle E	6635 Dawn E	6607 Woodrose E	6635 Dawn E
2823 Driftwood Speckle	6631 Cream	6608 Driftwood	6631 Cream
2824 Smoke Speckle	6636 Mist	6609 Smoke E	6636 Mist
2825 Vanadium Speckle	6619 Ice E	6612 Grey Value 2 E	6612 Grey Value 2 E
Woodgrain			
2406 Clear Cherry	6234 Clear Cherry	6001 Coffee	6001 Coffee
2409 Clear Maple	6237 Clear Maple	6655 Warm White	6655 Warm White
2410 Graphite Walnut	6231 Graphite Walnut	6000 Black	6000 Black
2412 Natural Cherry	6034 Natural Cherry	6001 Coffee	6001 Coffee
2422 Medium Cherry	6036 Medium Cherry	6001 Coffee	6001 Coffee
2511 Winter on Maple	6037 Winter on Maple	6655 Warm White	6655 Warm White
2538 Clear Walnut	6245 Clear Walnut	6000 Black	6000 Black
2539 Warm Oak E	6246 Warm Oak E	6655 Warm White	6655 Warm White
2592 Blonde on Maple	6038 Blonde on Maple	6655 Warm White	6655 Warm White
2714 Natural Walnut	6041 Natural Walnut	6001 Coffee	6001 Coffee
2772 Medium Mahogany on Walnut E	6045 Medium Mahogany on Walnut E	6001 Coffee	6001 Coffee
2HAK Clear Oak	6219 Clear Oak	6655 Warm White	6655 Warm White
2HAT Acacia	6213 Acacia	6655 Warm White	6655 Warm White

E = Established

Plastic Color Availability Matrix

Not every plastic component is available in every plastic color. The matrix below gives you an overview of which plastic colors can be specified for each plastic component.

	6000 Black	6009 Arctic White	6249 Platinum Solid	6651 Tungsten E	6652 Titanium E	6653 Solar Black E	6654 Sand	6681 Grotto
Internode mounting bracket	•	•	•	•	•	■	•	•
Internode power module covers	•	•	•	•	•	■	•	•
Internode convenience tri-receptacles	■	•	•	•	•	•	•	•
Internode convenience tri-receptacle housing	■	■	■	■	■	■	■	■
Internode convenience communication outlet housing	■	■	■	■	■	■	■	■
Above worksurface clamp kit	•	•	•	•	•	■	•	•
Internode modular infeed cover	■	■	■	■	■	■	■	■
Internode receptacles	■	■	■	■	■	■	■	■
Internode cord and cable manager	•	•	•	•	•	■	•	•

Legend

- = Not available
- = Available
- E** = Established

Ellipse Open Line Laminate Edge Coordination Matrix

1 mm and T-Mold Edges and Grommets

The colors of the 1 mm and T-mold edges and grommets

are determined by the 2K finish number selected.

Combination of Edging and Grommets will be:

2K Number Selection	Plastic 1 mm Edge Color	Plastic T-Mold Edge Color	Plastic Grommet Color
2K00	6619 Ice E	6612 Grey Value 2 E	6612 Grey Value 2 E
2K01	6245 Clear Walnut	6000 Black	6000 Black
2K03	6246 Warm Oak E	6655 Warm White	6655 Warm White
2K04	6234 Clear Cherry	6001 Coffee	6001 Coffee
2K10	6041 Natural Walnut	6001 Coffee	6001 Coffee
2K15	6615 Grey Value 5	6615 Grey Value 5	6000 Black
2K21	6036 Medium Cherry	6001 Coffee	6001 Coffee
2K22	6631 Cream	6631 Cream	6608 Driftwood E
2K27	6034 Natural Cherry	6001 Coffee	6001 Coffee
2K35	6638 Fog	6038 Fog	6609 Smoke E
2K38	6009 Arctic White	6009 Arctic White	6009 Arctic White
2K48	6654 Sand	6654 Sand	6608 Driftwood E
2K49	6053 Seagull	6053 Seagull	6053 Seagull
2K50	6052 Milk	6052 Milk	6052 Milk
2K52	6249 Platinum Solid	6249 Platinum Solid	6249 Platinum Solid
2K59	6655 Warm White	6655 Warm White	6655 Warm White
2K66	6037 Winter on Maple	6615 Grey Value 5	6000 Black
2K71 E	6045 Medium Mahogany on Walnut E	6001 Coffee	6001 Coffee
2K74	6237 Clear Maple	6655 Warm White	6655 Warm White
2K75	6231 Graphite Walnut	6000 Black	6000 Black
2K85	6615 Grey Value 5	6000 Black	6000 Black
2K92	6000 Black	6000 Black	6000 Black
2K93	6001 Coffee	6001 Coffee	6001 Coffee
2K94	6001 Dawn	6001 Dawn	6607 Woodrose E
2K98	6636 Mist	6636 Mist	6609 Smoke E
2KAC	6213 Acacia	6655 Warm White	6655 Warm White
2KAC	6213 Acacia	6655 Warm White	6655 Warm White
2KAK	6219 Clear Oak	6655 Warm White	6655 Warm White
2900			

Tip: To improve consistency, default edge colors are now identified by 6000-series numbers; actual colors and defaults have not changed. Because default edge colors are not actually entered when specifying products, no specification changes are required. (Previous specification guides used 2000-series numbers to describe default edge colors, while 6000-series numbers were used for customer-specified edge colors, even though the edges were identical.)

▶ See the *Surface Materials Reference Manual* for more details.

Tip: Use 2900 for products without default edge colors.

Tip: Enter the 2K-edge detail number in the finish field, and include a complete description of the laminate to be used.

Tip: Standard laminates being used in the Open Line Laminate program to obtain a different edge detail will be charged the processing fee upcharge; however, no additional charges for the laminate will be applied.

E = Established

Universal Storage Edge Coordination Matrix

Universal Storage Edge
Coordination Matrix

Recommended Front Edge Colors for Universal Storage Square Edge Laminate Tops

Edges

The recommended edge color will complement the laminate color you specify. Edge color is specified separately.

Laminate Color	Recommended Edge Color	Laminate Color	Recommended Edge Color
Fiber		Turnstone Laminate Collection*	
2850 Vanadium Fiber	6654 Sand	2535 Virginia Walnut	6242 Virginia Walnut
2851 Rhyme Fiber E	6631 Cream	2536 Blackwood	6243 Blackwood
2852 Tungsten Fiber	6636 Mist	2612 Marbled Maple	6676 Marbled Maple
2854 Vellum Fiber	6655 Warm White	2614 Chocolate Walnut	6677 Chocolate Walnut
2859 Novell Fiber	6001 Coffee	2615 Marbled Cherry	6678 Marbled Cherry
2860 Granite Fiber	6000 Black	*A selection of laminates and edge bands in this collection are available on Steelcase brand products. This collection is available with standard lead times and supported like standard laminates to help make ordering easy.	
2861 Coconut Fiber	6654 Sand		
2862 Stucco Fiber	6053 Seagull		
Micro			
2920 Marl Micro	6053 Seagull		
2921 Gypsum Micro	6654 Sand		
2922 Clay Micro	6654 Sand		
2923 Shadow Micro E	6249 Platinum Solid		
Patina			
2870 Blonde Bronze Patina	6654 Sand		
2871 Blackened Bronze Patina	6615 Grey Value 5		
2873 Instant Iron Patina	6615 Grey Value 5		
Solid			
2722 Cream E	6631 Cream		
2730 Arctic White	6009 Arctic White		
2746 Black	6000 Black		
2759 Warm White E	6655 Warm White		
2811 Mist E	6636 Mist		
2883 Seagull	6053 Seagull		
2884 Milk	6052 Milk		
2885 Dune	6654 Sand		
Speckle			
2820 Coffee Speckle	6631 Cream		
2822 Woodrose Speckle E	6635 Dawn E		
2823 Driftwood Speckle	6631 Cream		
2824 Smoke Speckle	6636 Mist		
2825 Vanadium Speckle	6619 Ice E		
Woodgrain			
2406 Clear Cherry	6234 Clear Cherry		
2409 Clear Maple	6237 Clear Maple		
2410 Graphite Walnut	6231 Graphite Walnut		
2412 Natural Cherry	6034 Natural Cherry		
2422 Medium Cherry	6036 Medium Cherry		
2511 Winter on Maple	6037 Winter on Maple		
2538 Clear Walnut	6245 Clear Walnut		
2539 Warm Oak E	6246 Warm Oak E		
2592 Blonde on Maple	6038 Blonde on Maple		
2714 Natural Walnut	6041 Natural Walnut		
2772 Medium Mahogany on Walnut E	6045 Medium Mahogany on Walnut E		
2HAK Clear Oak	6219 Clear Oak		
2HAT Acacia	6213 Acacia		

E = Established

Surface Materials Application Topics

Customer's Own Material Yardage Requirements

Pre-approved fabrics are available. To determine if the fabric you want is on the pre-approved list, call a COM Consultant at 616.246.9822.

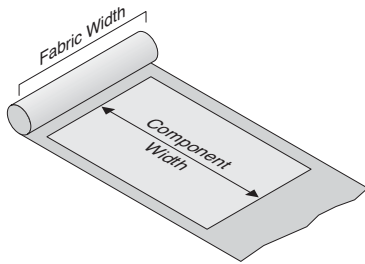

For information regarding COM fabrics, refer to the *Steelcase Surface Materials Reference Manual*.

Component width is parallel to fabric length for all Ellipse screens.

Additional fabric is required to accommodate flaws, wrinkles, and other imperfections. Calculate the total yardage and add the appropriate percentage shown below.

Resources

Lock and Keying	142
Style Number Index	144

Lock and Keying

All locking products are standard with factory-installed, keyed-random locks. Consecutive, specific, and random keying are available as field-installed options.
Exceptions: Individual locking drawers are available only with field-installed locks.

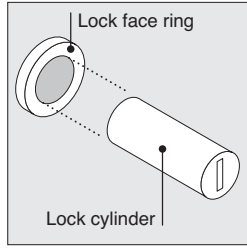

Locks consist of a factory- or field-installed lock cylinder and a factory-installed lock face ring.

Two types of locks are available — the standard keying system (FR series) and the master keying system (XF series). All the locks in the XF series can be opened with a single master key.

Factory-Installed Keying

Factory-installed locks are always key random (standard) or master key random (option). Key random means that the locks will be assigned arbitrarily at the factory with key numbers ranging from FR305 to FR454 (Master keying numbers: XF1001 to XF1150). All locks within a unit will be keyed alike.

Tip: Random keying can mean that different furniture units will have the same key number. If you must have all locks keyed differently, you should specify field-installed, key specific or key consecutive lock cylinders.
 ▶ See below.

- Key Random**
- FR305
 - FR421
 - FR305
- or
- XF1011
 - XF1042
 - XF1011
- } XF Master Key

Required to Specify

Master key random +\$23 Specify with master key random.

Field-Installed Keying

Field-installed locks are only available on products that include factory-installed lock mechanisms.

Specify "plug" when specifying furniture, and the product will ship with a plastic plug in place of the lock cylinder.
Tip: For products with optional lock colors, make sure to specify the color for both the lock and lock face ring.

Front-removable lock cylinders must be specified separately. You must also order a special lock tool to install or remove lock cylinders in the field.
Tip: Lock tools are reusable. You do not need to order additional lock tools with every furniture order.

Lock cylinders will be shipped separately so that you can install the locks when you are ready.

Three keying choices are available for field installation—random (standard), specific, and consecutive. All three are also available with master keying, which means that all locks can be opened with a single master key.

Key random means that the locks will be assigned arbitrarily at the factory with key numbers ranging from FR305 to FR454 (Master keying numbers: XF1001 to XF1150).
Tip: Random keying can mean that different furniture units will have the same key number. If you must have all locks keyed differently, you should specify key specific or key consecutive lock cylinders.

Key specific means that you can specify any key number from FR305 to FR454 (Master keying numbers: XF1001 to XF1150). This option can be used to key all the furniture units in a workstation or department the same.
Tip: Designate the quantity per key number in your specification.
 ▶ See example at right.

Key consecutive means that you can specify lock numbers in a consecutive order to ensure that no two locks have the same key number until the key sequence repeats. You must select a beginning key number from FR305 to FR454 (Master keying numbers: XF1001 to XF1150).

Example of a typical lock cylinder specification is shown below:

10	LOCK9201FR FR320
5	LOCK9201FR FR350
15	LOCK9201XF XF1100
30	Total
1	877102003SR standard lock tool
1	877102002SR master lock tool

- Key Random**
- FR305
 - FR421
 - FR305
- or
- XF1011
 - XF1042
 - XF1011
- } XF Master Key

- Key Specific**
- FR350
 - FR350
 - FR350
- or
- XF1020
 - XF1020
 - XF1020
- } XF Master Key

- Key Consecutive**
- FR350
 - FR351
 - FR352
- or
- XF1020
 - XF1021
 - XF1022
- } XF Master Key

Field-Installed Lock Cylinders

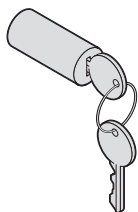

Tip: Lock price is included in price of furniture with locks.

Tip: For replacement lock cylinders, refer to Service Parts.

Standard Includes	Required to Specify
-------------------	---------------------

- | | |
|--|--|
| <ul style="list-style-type: none"> Lock cylinder, keyed random: 9201 Polished Chrome or 9250 Ember Chrome Two keys | <ul style="list-style-type: none"> 1 Style number 2 Options, if selected (see below) |
|--|--|

Options	U.S. Price	Required to Specify
---------	------------	---------------------

Key specific	No cost	Select key number from FR305–FR454.
Key consecutive	No cost	Specify <i>key consecutive</i> and select beginning key number from FR305–FR454.
Master key random	+\$23 each	Specify <i>master key random</i> .
Master key specific	+\$23 each	Specify key number from XF1001–XF1150.
Master key consecutive	+\$23 each	Specify <i>master key consecutive</i> and select beginning key number from XF1001–XF1150.

Specification Information		
Color	Style Number	U.S. Base Price

Color	Style Number	U.S. Base Price

FR Series (Standard Keying System) – Lock Cylinder

Polished Chrome	LOCK9201FR	N.A
Ember Chrome	LOCK9250FR	N.A

Standard Lock Tool

877102003SR	\$23

XF Series (Master Keying System) – Lock Cylinder

Polished Chrome	LOCK9201XF	No additional cost. Price included in price of furniture with master-keyed locks.
Ember Chrome	LOCK9250XF	No additional cost. Price included in price of furniture with master-keyed locks.

Master Lock Tool

877102002SR	\$23



For Canadian Pricing
 Multiply U.S. Price by the Canadian price factor.
 ▶ See page 1 for details.

Style Number Index

Style Number	Page	Description
800DV12	103	Dividers
800DV6	103	Dividers
800RW	103	Rail
877102002SR	143	Master Lock Tool
877102003SR	143	Standard Lock Tool
AABX0000X2	67	Ellipse Support
AAES0000X1	71	Ellipse Pwr Beam Recept
AASX1230L8	69	Ellipse Transaction Top
AASX1236L9	69	Ellipse Transaction Top
AASX1242L0	69	Ellipse Transaction Top
AASX1248L1	69	Ellipse Transaction Top
AASX1254L2	69	Ellipse Transaction Top
AASX1260L1	69	Ellipse Transaction Top
AASX1266L3	69	Transaction Top
AASX1272L0	69	Ellipse Transaction Top
AATX3012X5	68	Ellipse Screen
AATX3022X6	68	Ellipse Screen
AATX3612X1	68	Ellipse Screen
AATX3622X2	68	Ellipse Screen
AATX4212X4	68	Ellipse Screen
AATX4222X5	68	Ellipse Screen
AATX4812X0	68	Ellipse Screen
AATX4822X1	68	Ellipse Screen
AATX5412X3	68	Ellipse Screen
AATX5422X4	68	Ellipse Screen
AATX6012X6	68	Ellipse Screen
AATX6022X7	68	Ellipse Screen
AATX6612X2	68	Ellipse Screen
AATX6622X3	68	Ellipse Screen
AATX7212X2	68	Ellipse Screen
AATX7222X3	68	Ellipse Screen
ADBB42	59	Ellipse Desk
ADBB48	59	Ellipse Desk
ADBB54	59	Ellipse Desk
ADBB60	59	Ellipse Desk
ADBB72	59	Ellipse Desk
ADCP2442L0	61	Ellipse Corner Desk
ADCP2448L1	61	Ellipse Corner Desk
ADCP3042L2	61	Ellipse Corner Desk
ADCP3048L3	61	Ellipse Corner Desk
ADXM2430L8	53	Ellipse Desk
ADXM2436L0	53	Ellipse Desk
ADXM2442L5	53	Ellipse Desk
ADXM2448L7	53	Ellipse Desk
ADXM2460L7	53	Ellipse Desk
ADXM2466L5	53	Ellipse Desk
ADXM2472L4	53	Ellipse Desk
ADXM3030L1	55	Ellipse Desk
ADXM3036L3	55	Ellipse Desk
ADXM3042L8	55	Ellipse Desk
ADXM3048L0	55	Ellipse Desk
ADXM3054L5	55	Ellipse Desk
ADXM3060L0	55	Ellipse Desk
ADXM3066L8	55	Ellipse Desk
ADXM3072L7	55	Ellipse Desk

Style Number	Page	Description
ADXM3660L6	57	Ellipse Desk
ADXM3672L3	57	Ellipse Desk
ADXP2430L7	53	Ellipse Desk
ADXP2436L9	53	Ellipse Desk
ADXP2442L4	53	Ellipse Desk
ADXP2448L6	53	Ellipse Desk
ADXP2460L6	53	Ellipse Desk
ADXP2466L3	53	Ellipse Desk
ADXP2472L3	53	Ellipse Desk
ADXP3030L0	55	Ellipse Desk
ADXP3036L2	55	Ellipse Desk
ADXP3042L7	55	Ellipse Desk
ADXP3048L9	55	Ellipse Desk
ADXP3054L4	55	Ellipse Desk
ADXP3060L9	55	Ellipse Desk
ADXP3066L6	55	Ellipse Desk
ADXP3072L6	55	Ellipse Desk
ADXP3660L5	57	Ellipse Desk
ADXP3672L2	57	Ellipse Desk
AJHM3090L2	63	Ellipse Triang Junct Top
AJHP3090L1	63	Ellipse Triang Junct Top
AJHS3090L0	63	Ellipse Triang Junct Top
AJRM2390L1	62	Ellipse Radius Junct Top
AJRM3090L5	62	Ellipse Radius Junct Top
AJRM3290L7	62	Ellipse Radius Junct Top
AJRP2390L0	62	Ellipse Radius Junct Top
AJRP3090L4	62	Ellipse Radius Junct Top
AJRP3290L6	62	Ellipse Radius Junct Top
AJRS2390L9	62	Ellipse Radius Junct Top
AJRS3090L3	62	Ellipse Radius Junct Top
AJRS3290L5	62	Ellipse Radius Junct Top
AJTP3090L6	63	Ellipse Triang Junct Top
AJTS3090L5	63	Ellipse Triang Junct Top
ARAL2430L0	60	Ellipse Return
ARAL2436L2	60	Ellipse Return
ARAL2442L7	60	Ellipse Return
ARAL2448L9	60	Ellipse Return
ARAL2460L9	60	Ellipse Return
ARAR2430L8	60	Ellipse Return
ARAR2436L0	60	Ellipse Return
ARAR2442L5	60	Ellipse Return
ARAR2448L7	60	Ellipse Return
ARAR2460L7	60	Ellipse Return
ARFS0024X1	70	Ellipse Return Filler
ARFS0030X1	70	Ellipse Return Filler
ARFS0036X1	70	Ellipse Return Filler
ASGT1930L5	107	Top
ASGT1930V3	107	Top
ASGT1960L4	107	Top
ASGT1960V2	107	Top
ASGT1990L3	107	Top
ASGT1990V1	107	Top
ASHC1921X1	70	Plastic Drawer
ATCL3036L1	64	Ellipse Corner Cnf Table
ATCR3036L9	65	Ellipse Corner Cnf Table

Style Number	Page	Description	Style Number	Page	Description
ATGX0042L5	66	Round Conf Table	GSGUFC	109	Mdlr Infeed Cover
ATLX4278L1	66	Rect Conf Table	GSGUFMH12X	109	Internode Infeed
ATML3036L5	64	Ellipse Corner Cnf Table	GSGUFMH12Y	109	Internode Infeed
ATMR3036L3	65	Ellipse Corner Cnf Table	GSGUFMH12Z	109	Internode Infeed
GFUCCM	120	Cord and Cable Mg	GSGUFMH24X	109	Internode Infeed
GFUCH	118	Convenience Comm Housing	GSGUFMH24Y	109	Internode Infeed
GFUCMC	120	Internode Harness Clip	GSGUFMH24Z	109	Internode Infeed
GFUFFH12X	108	Floor Power Infeed	GSGUFMM12X	109	Internode Infeed
GFUFFH12Y	108	Floor Power Infeed	GSGUFMM12Y	109	Internode Infeed
GFUFFH12Z	108	Floor Power Infeed	GSGUFMM12Z	109	Internode Infeed
GFUFFH6X	108	Floor Power Infeed	GSGUFMM24X	109	Internode Infeed
GFUFFH6Y	108	Floor Power Infeed	GSGUFMM24Y	109	Internode Infeed
GFUFFH6Z	108	Floor Power Infeed	GSGUFMM24Z	109	Internode Infeed
GFUMB	111	Mounting Bracket	GSGUH100X	112	Internode Harness
GFUPMBX	110	Power Module	GSGUH100Y	113	Internode Harness
GFUPMBXNYC	110	Power Module	GSGUH100Z	113	Internode Harness
GFUPMBY	110	Power Module	GSGUH120X	112	Internode Harness
GFUPMBYNYC	110	Power Module	GSGUH120Y	113	Internode Harness
GFUPMBZ	110	Power Module	GSGUH120Z	113	Internode Harness
GFUPMBZNYC	110	Internode Power Module	GSGUH12X	112	Internode Harness
GFUPMX	110	Power Module	GSGUH12Y	112	Internode Harness
GFUPMXNYC	110	Power Module	GSGUH12Z	113	Internode Harness
GFUPMY	110	Power Module	GSGUH144X	112	Internode Harness
GFUPMYNYC	110	Power Module	GSGUH144Y	113	Internode Harness
GFUPMZ	110	Power Module	GSGUH144Z	113	Internode Harness
GFUPMZNYC	110	Internode Power Module	GSGUH22X	112	Internode Harness
GFUSCM	114	Comm Module	GSGUH22Y	112	Internode Harness
GFUT1G72X	117	Convenience Tri-Receptacle	GSGUH22Z	113	Internode Harness
GFUT1G72Y	117	Convenience Tri-Receptacle	GSGUH28X	112	Internode Harness
GFUT1G72Z	117	Convenience Tri-Receptacle	GSGUH28Y	112	Internode Harness
GFUT1S72X	117	Convenience Tri-Receptacle	GSGUH28Z	113	Internode Harness
GFUT1S72Y	117	Convenience Tri-Receptacle	GSGUH32X	112	Internode Harness
GFUT1S72Z	117	Convenience Tri-Receptacle	GSGUH32Y	112	Internode Harness
GFUT2G72X	117	Convenience Tri-Receptacle	GSGUH32Z	113	Internode Harness
GFUT2G72Y	117	Convenience Tri-Receptacle	GSGUH38X	112	Internode Harness
GFUT2G72Z	117	Convenience Tri-Receptacle	GSGUH38Y	112	Internode Harness
GFUT2S72X	117	Convenience Tri-Receptacle	GSGUH38Z	113	Internode Harness
GFUT2S72Y	117	Convenience Tri-Receptacle	GSGUH44X	112	Internode Harness
GFUT2S72Z	117	Convenience Tri-Receptacle	GSGUH44Y	112	Internode Harness
GFUT3G72X	117	Convenience Tri-Receptacle	GSGUH44Z	113	Internode Harness
GFUT3G72Y	117	Convenience Tri-Receptacle	GSGUH50X	112	Internode Harness
GFUT3G72Z	117	Convenience Tri-Receptacle	GSGUH50Y	112	Internode Harness
GFUT3S72X	117	Convenience Tri-Receptacle	GSGUH50Z	113	Internode Harness
GFUT3S72Y	117	Convenience Tri-Receptacle	GSGUH54X	112	Internode Harness
GFUT3S72Z	117	Convenience Tri-Receptacle	GSGUH54Y	113	Internode Harness
GFUT4G72X	117	Convenience Tri-Receptacle	GSGUH54Z	113	Internode Harness
GFUT4G72Y	117	Convenience Tri-Receptacle	GSGUH64X	112	Internode Harness
GFUT4S72X	117	Convenience Tri-Receptacle	GSGUH64Y	113	Internode Harness
GFUT4S72Y	117	Convenience Tri-Receptacle	GSGUH64Z	113	Internode Harness
GFUTMB	119	Mounting Bracket	GSGUH76X	112	Internode Harness
GFUTMC	119	Clamp Kit	GSGUH76Y	113	Internode Harness
GFUTP96	118	Cnvc Tri-Receptacle	GSGUH76Z	113	Internode Harness
GSGUBCX	110	Connector	GSGUH88X	112	Internode Harness
GSGUBCY	110	Connector	GSGUH88Y	113	Internode Harness
GSGUBCZ	110	Internode Connector	GSGUH88Z	113	Internode Harness

Style Number Index, continued

Style Number	Page	Description
GSGUHCX	112	Harness Connector
GSGUHHX	112	Internode Harness
GSGUHHY	113	Internode Harness
GSGUHHZ	113	Internode Harness
GSGUR1SGX	115	Internode Receptacle
GSGUR1SGY	115	Internode Receptacle
GSGUR1SGZ	116	Internode Receptacle
GSGUR1SSX	115	Internode Receptacle
GSGUR1SSY	115	Internode Receptacle
GSGUR1SSZ	116	Internode Receptacle
GSGUR1TGX	115	Internode Receptacle
GSGUR1TGY	115	Internode Receptacle
GSGUR1TGZ	116	Internode Receptacle
GSGUR1TSX	115	Internode Receptacle
GSGUR1TSY	115	Internode Receptacle
GSGUR1TSZ	116	Internode Receptacle
GSGUR2SGX	115	Internode Receptacle
GSGUR2SGY	115	Internode Receptacle
GSGUR2SGZ	116	Internode Receptacle
GSGUR2SSX	115	Internode Receptacle
GSGUR2SSY	115	Internode Receptacle
GSGUR2SSZ	116	Internode Receptacle
GSGUR2TGX	115	Internode Receptacle
GSGUR2TGY	115	Internode Receptacle
GSGUR2TGZ	116	Internode Receptacle
GSGUR2TSX	115	Internode Receptacle
GSGUR2TSY	115	Internode Receptacle
GSGUR2TSZ	116	Internode Receptacle
GSGUR3SGX	115	Internode Receptacle
GSGUR3SGY	115	Internode Receptacle
GSGUR3SGZ	116	Internode Receptacle
GSGUR3SSX	115	Internode Receptacle
GSGUR3SSY	115	Internode Receptacle
GSGUR3SSZ	116	Internode Receptacle
GSGUR3TGX	115	Internode Receptacle
GSGUR3TGY	115	Internode Receptacle
GSGUR3TGZ	116	Internode Receptacle
GSGUR3TSX	115	Internode Receptacle
GSGUR3TSY	115	Internode Receptacle
GSGUR3TSZ	116	Internode Receptacle
GSGUR4SGX	115	Internode Receptacle
GSGUR4SGY	115	Internode Receptacle
GSGUR4SSX	115	Internode Receptacle
GSGUR4SSY	115	Internode Receptacle
GSGUR4TGX	115	Internode Receptacle
GSGUR4TGY	115	Internode Receptacle
GSGUR4TSX	115	Internode Receptacle
GSGUR4TSY	115	Internode Receptacle
KDIV02	104	Bookends
KDIV20	104	Bookends
LOCK9201FR	143	Lock Cylinder
LOCK9201XF	143	Lock Cylinder
LOCK9250FR	143	Lock Cylinder
LOCK9250XF	143	Lock Cylinder
LPTL30	127	LED Personal Task Light

Style Number	Page	Description
LPTL30NR	127	LED Personal Task Light
LS1FSC	123	Daisy Chain Cord
LS6FSC	123	Daisy Chain Cord
LSB24K2	124	Utility2 Shelf Light
LSB24KC2	124	Utility2 Shelf Light
LSB24KD2	124	Utility2 Shelf Light
LSB24KS2	124	Utility2 Shelf Light
LSB24M2	125	Utility2 Shelf Light
LSB24MC2	125	Utility2 Shelf Light
LSB24MD2	125	Utility2 Shelf Light
LSB24MS2	125	Utility2 Shelf Light
LSB36K2	124	Utility2 Shelf Light
LSB36KC2	124	Utility2 Shelf Light
LSB36KD2	124	Utility2 Shelf Light
LSB36KS2	124	Utility2 Shelf Light
LSB36M2	125	Utility2 Shelf Light
LSB36MC2	125	Utility2 Shelf Light
LSB36MD2	125	Utility2 Shelf Light
LSB36MS2	125	Utility2 Shelf Light
LSB48K2	124	Utility2 Shelf Light
LSB48KC2	124	Utility2 Shelf Light
LSB48KD2	124	Utility2 Shelf Light
LSB48KS2	124	Utility2 Shelf Light
LSB48M2	125	Utility2 Shelf Light
LSB48MC2	125	Utility2 Shelf Light
LSB48MD2	125	Utility2 Shelf Light
LSB48MS2	125	Utility2 Shelf Light
LSL18	126	LED Light
LSL18YA	126	LED Light
LSL18YB	126	LED Light
LSM24K	122	Standard Light
LSM24KC	122	Standard Light
LSM24KD	122	Standard Light
LSM36K	122	Standard Light
LSM36KC	122	Standard Light
LSM36KD	122	Standard Light
LSM48K	122	Standard Light
LSM48KC	122	Standard Light
LSM48KD	122	Standard Light
RAACW1	105	Counterweight Pkg
RAACW2	105	Counterweight Pkg
RAACW3	105	Counterweight Pkg
RAACW4	105	Counterweight Pkg
RAACW5	105	Counterweight Pkg
RAANBRK	106	Anchor Bracket Pkg
RAHF30	102	Hanging Folder Bars
RAHF36	102	Hanging Folder Bars
RAHF42	102	Hanging Folder Bars
RASTDIV30	104	Shelf Divider Assembly
RASTDIV36	104	Shelf Divider Assembly
RASTDIV42	104	Shelf Divider Assembly
RATCL18108_	98	Square Edge Top
RATCL1860_	98	Square Edge Top
RATCL1866_	98	Square Edge Top
RATCL1872_	98	Square Edge Top

Style Number	Page	Description	Style Number	Page	Description
RATCL1878_	98	Square Edge Top	RCC18306V_	88	Univ Combination Cabinet
RATCL1884_	98	Square Edge Top	RCC18364A_	86	Univ Combination Cabinet
RATCL1890_	98	Square Edge Top	RCC18364D_	86	Univ Combination Cabinet
RATCL1896_	98	Square Edge Top	RCC18365E_	86	Univ Combination Cabinet
RATCL24108_	99	Square Edge Top	RCC18365H_	86	Univ Combination Cabinet
RATCL2460_	99	Square Edge Top	RCC18365J_	87	Univ Combination Cabinet
RATCL2466_	99	Square Edge Top	RCC18365M_	87	Univ Combination Cabinet
RATCL2472_	99	Square Edge Top	RCC18366N_	87	Univ Combination Cabinet
RATCL2490_	99	Square Edge Top	RCC18366R_	87	Univ Combination Cabinet
RATCL2496_	99	Square Edge Top	RCC18366S_	88	Univ Combination Cabinet
RATCL3636_	99	Square Edge Top	RCC18366V_	88	Univ Combination Cabinet
RATCL3672_	99	Square Edge Top	RCC18424A_	86	Univ Combination Cabinet
RATCL4836_	99	Square Edge Top	RCC18424D_	86	Univ Combination Cabinet
RATCL4872_	99	Square Edge Top	RCC18425E_	86	Univ Combination Cabinet
RATCW1860_	99	Square Edge Top	RCC18425H_	86	Univ Combination Cabinet
RATCW1866_	99	Square Edge Top	RCC18425J_	87	Univ Combination Cabinet
RATCW1872_	99	Square Edge Top	RCC18425M_	87	Univ Combination Cabinet
RATCW1878_	99	Square Edge Top	RCC18426N_	87	Univ Combination Cabinet
RATCW1884_	99	Square Edge Top	RCC18426R_	87	Univ Combination Cabinet
RATCW1890_	99	Square Edge Top	RCC18426S_	88	Univ Combination Cabinet
RATCW1896_	99	Square Edge Top	RCC18426V_	88	Univ Combination Cabinet
RATCW2460_	99	Square Edge Top	RCC24304A_	86	Univ Combination Cabinet
RATCW2466_	99	Square Edge Top	RCC24304D_	86	Univ Combination Cabinet
RATCW2472_	99	Square Edge Top	RCC24305E_	86	Univ Combination Cabinet
RATCW2490_	99	Square Edge Top	RCC24305H_	86	Univ Combination Cabinet
RATCW2496_	99	Square Edge Top	RCC24305J_	87	Univ Combination Cabinet
RATF1830F	97	Steel Security Top	RCC24305M_	87	Univ Combination Cabinet
RATF1830P	97	Steel Security Top	RCC24306N_	87	Univ Combination Cabinet
RATF1836F	97	Steel Security Top	RCC24306R_	87	Univ Combination Cabinet
RATF1836P	97	Steel Security Top	RCC24306S_	88	Univ Combination Cabinet
RATF1842F	97	Steel Security Top	RCC24306V_	88	Univ Combination Cabinet
RATF1842P	97	Steel Security Top	RCC24364A_	86	Univ Combination Cabinet
RATF2430F	97	Steel Security Top	RCC24364D_	86	Univ Combination Cabinet
RATF2430P	97	Steel Security Top	RCC24365E_	86	Univ Combination Cabinet
RATF2436F	97	Steel Security Top	RCC24365H_	86	Univ Combination Cabinet
RATF2436P	97	Steel Security Top	RCC24365J_	87	Univ Combination Cabinet
RATL1830_	98	Square Edge Top	RCC24365M_	87	Univ Combination Cabinet
RATL1836_	98	Square Edge Top	RCC24366N_	87	Univ Combination Cabinet
RATL1842_	98	Square Edge Top	RCC24366R_	87	Univ Combination Cabinet
RATL2430_	98	Square Edge Top	RCC24366S_	88	Univ Combination Cabinet
RATL2436_	98	Square Edge Top	RCC24366V_	88	Univ Combination Cabinet
RATW1830_	99	Square Edge Top	RDIV	70	Dividers
RATW1836_	99	Square Edge Top	RDV1506	101	Dividers
RATW1842_	99	Square Edge Top	RDV1512	101	Dividers
RATW2430_	99	Square Edge Top	RDV151210	101	Dividers
RATW2436_	99	Square Edge Top	RLF18302_	82	Univ Lat File
RCC18304A_	86	Univ Combination Cabinet	RLF18303_	82	Univ Lat File
RCC18304D_	86	Univ Combination Cabinet	RLF18304_	82	Univ Lat File
RCC18305E_	86	Univ Combination Cabinet	RLF18305_	83	Univ Lat File
RCC18305H_	86	Univ Combination Cabinet	RLF18362_	82	Univ Lat File
RCC18305J_	87	Univ Combination Cabinet	RLF18363_	82	Univ Lat File
RCC18305M_	87	Univ Combination Cabinet	RLF18364_	82	Univ Lat File
RCC18306N_	87	Univ Combination Cabinet	RLF18365_	83	Univ Lat File
RCC18306R_	87	Univ Combination Cabinet	RLF18422_	82	Univ Lat File
RCC18306S_	88	Univ Combination Cabinet	RLF18423_	82	Univ Lat File

Style Number Index, continued

Style Number	Page	Description
RLF18424_	82	Univ Lat File
RLF18425_	83	Univ Lat File
RLF24302_	82	Univ Lat File
RLF24303_	82	Univ Lat File
RLF24304_	82	Univ Lat File
RLF24305_	83	Univ Lat File
RLF24362_	82	Univ Lat File
RLF24363_	82	Univ Lat File
RLF24364_	82	Univ Lat File
RLF24365_	83	Univ Lat File
RPAH1815C_	79	Ellipse Univ Hanging Pedestal
RPF1825A_	73	Univ Fixed Pedestal
RPF1825B_	73	Univ Fixed Pedestal
RPF1827A_	73	Univ Fixed Pedestal
RPF1827B_	73	Univ Fixed Pedestal
RPM1821C_	78	Univ Mobile Pedestal
RPM1827A_	78	Univ Mobile Pedestal
RPM1827B_	78	Univ Mobile Pedestal
RPM2421C_	78	Univ Mobile Pedestal
RPM2427A_	78	Univ Mobile Pedestal
RPM2427B_	78	Univ Mobile Pedestal
RPULL15W	105	Wood Drawer Pull
RPULL30W	105	Wood Drawer Pull
RPULL36W	105	Wood Drawer Pull
RPULL42W	105	Wood Drawer Pull
RPXCK2518P	74	Univ Conversion Kit
RPXCK2524P	74	Univ Conversion Kit
RPXCK2530P	74	Univ Conversion Kit
RPXCK2718P	74	Univ Conversion Kit
RPXCK2724P	74	Univ Conversion Kit
RPXCK2730P	74	Univ Conversion Kit
RPXDPT	102	Pencil Tray
RPXDRS	102	Reference Shelf
RPXTC24P	78	Univ Ped Cushion Top
RPXTCH24P	78	Univ Ped Cushion Top
RSC18302A_	91	Univ Storage Cabinet
RSC18303C_	92	Univ Storage Cabinet
RSC18304F_	92	Univ Storage Cabinet
RSC18305K_	92	Univ Storage Cabinet
RSC18306Q_	92	Univ Storage Cabinet
RSC18362A_	91	Univ Storage Cabinet
RSC18363C_	92	Univ Storage Cabinet
RSC18364F_	92	Univ Storage Cabinet
RSC18365K_	92	Univ Storage Cabinet
RSC18366Q_	92	Univ Storage Cabinet
RSC18422A_	91	Univ Storage Cabinet
RSC18423C_	92	Univ Storage Cabinet
RSC18424F_	92	Univ Storage Cabinet
RSC18425K_	92	Univ Storage Cabinet
RSC18426Q_	92	Univ Storage Cabinet
RSC24302A_	91	Univ Storage Cabinet
RSC24303C_	92	Univ Storage Cabinet
RSC24304F_	92	Univ Storage Cabinet
RSC24305K_	92	Univ Storage Cabinet
RSC24306Q_	92	Univ Storage Cabinet

Style Number	Page	Description
RSC24362A_	91	Univ Storage Cabinet
RSC24363C_	92	Univ Storage Cabinet
RSC24364F_	92	Univ Storage Cabinet
RSC24365K_	92	Univ Storage Cabinet
RSC24366Q_	92	Univ Storage Cabinet
RWC24304A_	95	Univ Wardrobe Cabinet
RWC24304B_	96	Univ Wardrobe Cabinet
RWC24305A_	95	Univ Wardrobe Cabinet
RWC24305C_	96	Univ Wardrobe Cabinet
RWC24306D_	95	Univ Wardrobe Cabinet
RWC24364A_	95	Univ Wardrobe Cabinet
RWC24364B_	96	Univ Wardrobe Cabinet
RWC24365A_	95	Univ Wardrobe Cabinet
RWC24365C_	96	Univ Wardrobe Cabinet
RWC24366D_	95	Univ Wardrobe Cabinet
RXADRL15	101	Rails
RXADRL24	103	Rails
RXADRL2442	103	Rails
RXSA1830	100	Adjustable Steel Standard Shelf
RXSA1836	100	Adjustable Steel Standard Shelf
RXSA1842	100	Adjustable Steel Standard Shelf
RXSA2424	100	Adjustable Steel Standard Shelf
RXSA2430	100	Adjustable Steel Standard Shelf
RXSA2436	100	Adjustable Steel Standard Shelf

Trademark List

- ® The following are registered trademarks for products of Steelcase Inc. or one of its related corporate entities: 4 o'clock, 900 Series, à la carte, Airtouch, Ally, Amia, Answer, Archipelago, Avenir, Ballet, Bix, Brayton International, Cachet, Canopy, Canto, Chancellor, Coalesse, Confidante, Context, Convene, CopyCam, Criterion, Crushed Can, Currency, dash, Designtex, Details, Detour, Drive, Elective Elements, Ellipse, Ember Chrome, Emerge, E-Table 2, FYI, Garland, Gentry, Ginkgo Biloba, Groupwork, Ideo, Jacket, Jenny, Jersey, Kart, Kick, LaCosta, Leap, Let's B, LiveBack, Max-Stacker, media:scape, Metro, Migrations, Mitra, Montage, Nurture, Oriana, Parade, Pathways, PCT, Permiso, Player, PolyVision, Portal, Power Pincher, Progeny, Protégé, R2, Rally, Relevant, Reply, Rizzi Arc, Sensor, Series 9000, Siento, Sieste, Sine, Softcare, Springboard, Steelcase, Steelcase Design Partnership, Stella, Stow Davis, Swathmore, TeamWork, Technique, Texpress, Think, Thunder, Topo, Train, Turnstone, Underline, Unison, Vecta, Viridian, Walden, Werndl, and X-Stack.
- ® The following registered trademarks are under license from AWI Licensing Company, Dover, DE: SoundScapes, DuraBrite, BioBlock, and Armstrong.
- ® The following registered trademarks are under license from Byrne Electrical, Rockford, MI: Interport, Mini-Port, Axil Z, and Ellora.
- ® The following is a registered trademark of DuPont, Wilmington, DE: Corian.
- ® The following is a registered trademark of Genlyte Thomas Company, Louisville, KY: Lightolier.
- ® The following is a registered trademark of Hilti Corporation, FL-9494 Schaan, Principality of Liechtenstein: Hilti.
- ® The following is a registered trademark of Leviton Manufacturing Company, Little Neck, NY: Decora.
- ® The following is a registered trademark of Mechanical Plastics Corp, Elmsford, NY: Toggler.
- ® The following is a registered trademark of Microsoft Corporation, Redmond, WA: Microsoft.
- ® The following is a registered trademark of Panduit Corporation, Lockport, IL: Panduit.
- ® The following is a registered trademark of Trav (Press), Cuneo, Italy: Assisa.
- ® The following is a registered trademark of Virtual Ink, Boston, MA: mimioActive.
- ® The following registered trademarks are under license from Wilkhahn Furniture Products: Avera, Senzo, Versal, and Wilkhahn FS.
- ® The following is a registered trademark of Wilsonart International, Temple, TX: Chemsurf.

- ® The following is a registered trademark of Wiremold, West Hartford, CT: Wiremold.
- ® The following is a registered trademark of EMU Group S.P.A., Perugia, Italy: Emu.
- ™ The following are trademarks for products of Steelcase Inc. or one of its related corporate entities: Access, Active/Passive Shelf, Ainsley, Akira, Alcove, Alerion, aLight, Amaris, American Elect, American Tradition, ap40, Arbor, Arriva, Asana, Ascot, Aspekt, Astor, Await, Bira, Bivi, Bottomline, Brook, Buoy, Burton, c:scape, Calla, Calm, Camber, Campfire, Capa, Cappuccino, Cesar, Chester, Chord, Circa, Clarendon, Classic Rectangular, cobi, Collaboration, Community, Company, Convey, Cortex, Coupe, Crea, Crew, Cura, Cypress, Davenport, Dearborn, Deck, Déjà, Denizen, Denska, Derby, Divisio, Donovan, Dune, Duo, e³, e³ ceramicsteel, e³ environmental ceramicsteel, Echo, Edge, Elsna, Empath, Empress, Enea, ēno, EnSync, Enviro, Escapade, Exchange, Exponents, Field, Flat Top, FlexFrame, Flip Top, Flute, Folio, FrameOne, FreeFlow, Frontier, Galilei, Gesture, Ginger, Ginkgo, Go Wall, Grip, Groove, Hatchback, Hawthorne, Hitch, Host Collection, Hosu, Huddleboard, i2i, Impact, Indy, InfoLink, IOS, I-Solve, Jack, Jarrah, Jetty, Juice, Kami, Kast, Kathryn, Lagunitas, Lark, L'Attitude, LearnLab, Leela, Lincoln, Linden, LiveSeat, Loria, Lyric, Malibu, Malibu Too, Mansfield, Marathon, Martini, Mason, Masque, Millbrae, Mineral, Mingle, Mystic, Mystic Metal, Mystic Wood, Montreal, Move, Nadia, Neighbor, nesso, Nickel, Nikko, Nod, Node, Norfolk, Ontrak, Oom, Opus, Orchid, Outlook Collection, Ovation, Paloma, Paperflo, Parliament, Pasio, Passerelle, Patriarch, Payback, Peek, Pile File, Pisa, Pool, PUCK, QiVi, Quba, Rave, Reed, Regard, Relay, Reunion, Ripple, Riser, Rocco, Rocky, RoomWizard, Runner, Satellite, Sawyer, ScapeSeries, Senti, Sentinel, Senza, Sequoia, Session, ShareLink, Shield, Shortcut, Sidewalk, Skylar, Slumber, Smoke, Snug, Soft Leaf, Sonata, Sorrel, SOTO, Stationkits, Stiletto, Surprise!, Switch, Symphony, Sync, TagWizard, Tava, TeamStudio, TeamTheater, Tenaro, Terrazzo, Theorem, Thread, Topaz, Touchdown, Tour, Tower Too, Trees, Trillium, Trolley, tX2, U-Free, Uno, V.I.A., Verb, Verge, Victor2, Visalia, Waldorf, Woodruff, Workspring, and X-tenz.
- ™ The following is a trademark of Microsoft Corporation, Redmond, WA: Windows.
- ™ The following is a trademark of Rodman Industries, Inc., Oconomowoc, WI: ResinCore1.
- ™ The following is a trademark of Ultrafabrics, LLC, Elmsford, NY: Ultraleather.
- ™ The following trademarks are under license from Wilkhahn Furniture products: Cana, Linus, Logon, Picto, Range, Stitz, Thema, Timetable, and Tubis.
- ™ The following is a trademark of MBDC, Charlottesville, VA: Cradle to Cradle and C2C.

- ™ The following trademarks are under license from Walter Knoll: Andoo, Bob, Lazlo, Lox, Ribbon, and Together.
 - ™ The following trademarks are under license from PP Möbler: Bar and Flag Halyard.
 - ™ The following trademarks are under license from Viccarbe: Davos, Holy Day, Last Minute, RS, and Wrapp.
 - ™ The following trademarks are under license from Carl Hansen: Elbow, Paddle, Shell, Wing, and Wishbone.
 - ™ The following trademarks are under license from Cambridge Sound Management, LLC, Cambridge, MA: QtPro Soundmasking, Qt Quiet Technology, and Sonet Qt.
 - ™ The following is a trademark of Electri-Cable Assemblies, Shelton, CT: Interact.
- Trademarks used here in are the property of Steelcase, Inc. or of their respective owners.*