

① Remove corner cap from FE-3 panel and top cap from post.

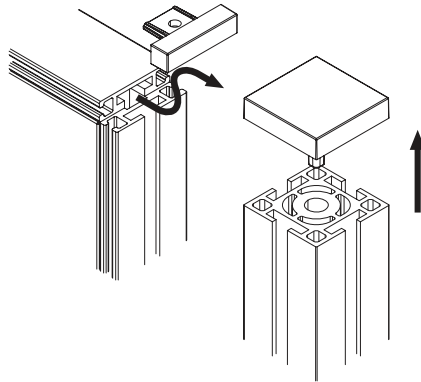

② Insert hinge into vertical slits from top of FE-3 panel and post. Drive in gently with rubber hammer, if necessary.

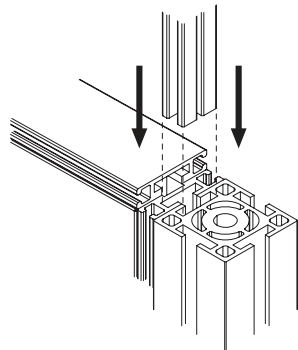

③ Be sure to have the Hinge up right with the hole on the top side. You will use this hole when taking Screens apart.

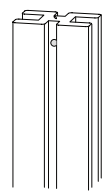

④ Insert a Inline Locking Block into Vertical Slits.

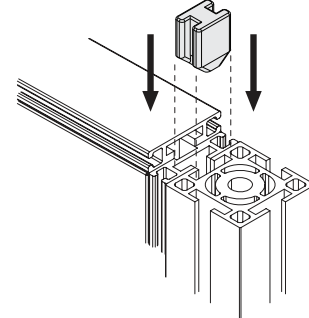

⑤ Reset top cap to post.

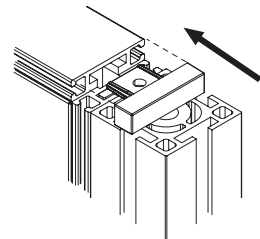

⑥ Reset top cap to post.

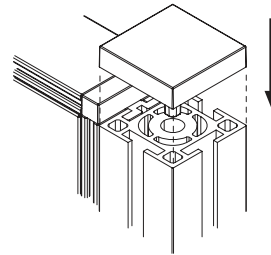

Hinge may need to be cut short if there are difference in height of screens.

⑦ Hinges are able to be cut with a cutter knife. Make sure to cut opposite end to the hole.

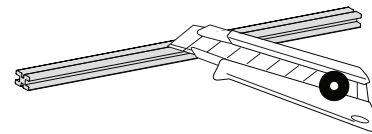

FE-3 Post (In-line, L, T, X)

Required Tools

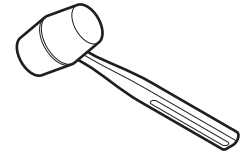

Rubber hammer

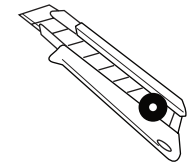

Cutter knife